

Retherm Oven	FL-RO151030
Rev. 3 (7/13)	Page 1 of 11

INSTALLATION, OPERATION and MAINTENANCE MANUAL for Cres Cor 8kW QUIK THERM™ RETHERM OVENS



RO151030

Retherm Oven	FL-RO151030
Rev. 3 (7/13)	Page 2 of 11

TABLE OF CONTENTS

SUBJECT	PAGE
INSTALLATION INSTRUCTIONS	3
OPERATING INSTRUCTIONS	
First Time Operation	3
How to Use Control for Cooking & Holding	4
How to Save and Use Recipes	5
“Quick Recipe” and Other Menu settings	5
MAINTENANCE INSTRUCTIONS	
How to Clean the Unit	6
Trouble Shooting Guide	7, 8
Cabinet Replacement Parts	9
Hot Unit Replacement Parts	10
Wiring Diagram For 208/240 Volt, 1 Phase	11
SERVICE POLICY and AGENCY LIST	FL-1400

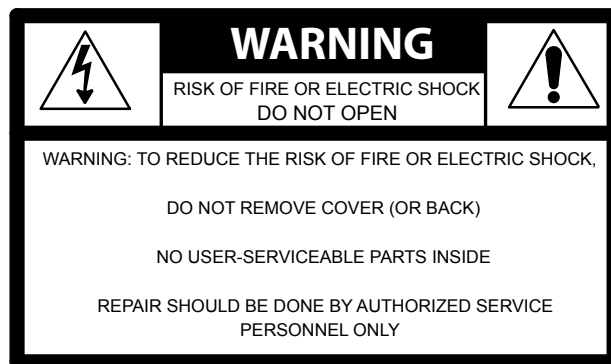

INSTALLATION INSTRUCTIONS

VENTING YOUR OVEN:

1. The purpose of ventilating hoods is to direct and capture smoke, grease-laden vapors, heat, odors, or fumes.
2. Low temperature equipment (maximum temperature 250°F/121°C) does not produce heat, odors, fumes, grease-laden vapors or smoke and is not required to be vented.
3. Most jurisdictions consider our low-temperature ovens (maximum temperature is 350°F/177°C) as low-heat appliances not requiring vent hoods.
4. Installation must conform with local codes. The authority having jurisdiction of enforcement of the codes will have the responsibility for making interpretations of the rules.

UNIT SPECIFICATIONS: Unit uses six (6) elements (1325 watts each). Units are rated 8000 watts.

MODEL NOS.	ELECTRICAL SPECS (AC SERVICE)			ELEC. LOAD		POWER SUPPLY REQUIREMENT ALL 3 PHASE IS 3 WIRE + GROUND			
	VOLTS	PHASES	HZ	AMPS	VOLTS	AMPS	PHASES	VOLTS	RECEPTACLE
RO151030	208	1	60	39	208	50	1	208	6-50R

HOW TO INSTALL CABINETS:

1. Remove all packing material from inside and outside of cabinet.
2. Position cabinet on level floor; install the cabinet interior (pan slides) if not already installed.
3. Plug power cord into proper wall receptacle.

FIRST-TIME OPERATION

NOTE: A new oven needs to “burn off” manufacturing oils and excessive adhesive before its first use.
Do NOT load food into oven until this has been done!

1. Push the switch to on; the light will come on.

NOTE: The letters “LOTPR” (low temperature) will show on the control panel until it reaches 140°F (60°C).

2. Press the “COOK” button.
3. Push down and turn the control knob to show 200°F. Push the knob again to set the temperature. Run the unit for one (1) hour.
4. Turn the unit off and let cool.
5. Wipe the inside clean with detergent and hot water.

Retherm Oven	FL-RO151030
Rev. 3 (7/13)	Page 4 of 11

OPERATING INSTRUCTIONS



HOW TO USE THE RETHERM CONTROL:

*Push the lighted switch on the control panel; the light will come on and the cabinet will start heating.

*The display will read “LOTPR” (low temperature) below 140°F. (60°C.).

NOTE: Wait one (1) hour after start up before loading the food for best results.

The display will read “PREHT” until the cabinet reaches the set temperature.

Cooking:

1. Press the COOK button.
2. Turn the control knob to the desired cooking temperature between 200°F (93°C) and 350°F (176°C).
3. Push the knob to set the temperature.
4. The control automatically goes to the HOLD mode. (Continue to step 1 below).

Holding:

(Press the HOLD button only if you are just holding food),

1. Turn the control knob to the desired holding temperature between 140°F (60°C) and 220°F (104°C).
2. Push the knob to set the temperature.
3. The control automatically goes to the TIME mode.

Setting the time or Food Probe:

1. If NOT using the Food Probe:
 - a) Turn the control knob to the desired hours/minutes.
 - b) Push the knob to set the time.
2. Using the Food Probe:

Plug in the food probe **BEFORE** you enter the **TIME** mode. Otherwise, you have to press the **PROBE** button to set the probe temperature.

 - a) Turn the knob to the desired temperature.
 - b) The timer will stop when the probe reaches the set temperature.
3. Press the **START** button. The display will show “READY” when preheated.
4. Press the **START** again to use this recipe (see Recipes”).

Note: Press the knob for 4 seconds to cancel the recipe.

The **DISPLAY** button shows (cycles through) all the values when in each mode:

- “PREHEAT” OR “READY”: momentarily shows the actual cabinet temperature.
- “COOK” (Timed): shows Home screen, set point, count down time, actual cabinet temperature.
- “COOK” (Probe): shows Home screen, set point, count up time, actual cabinet temperature.
- “HOLD”: shows Home screen, set point, count up time, actual cabinet temperature.

OPERATING INSTRUCTIONS *(continued)*



RECIPES:

The control can hold up to 18 saved recipes.

To save a recipe:

1. Press and hold both the TIME button and the knob for 5 seconds. The screen will be flashing. This is the setup menu.
2. Turn the knob through the menu until you get to "Edit".
3. Press the knob and turn to the recipe you want to edit. There are 18 blank recipes to customize and save.
4. Press the knob and enter the cook, hold and time values.
5. After the entering the final value, "Edit" will show again.
6. Press the knob to edit more recipes or turn to "End" to exit the menu.

To use one of the recipes:

1. Push one of the three RECIPE group buttons for the recipe number you want.
2. Turn the knob to the recipe you want and press the knob to select.
3. Press the START button to preheat.
4. After it shows "READY", press the START button again to begin the recipe.

Note: The display button will cycle through all the values as before, but will include the recipe number, if using a saved recipe.

Quick Recipe Note:

You can set "Quick Recipes" for recipes that you use often. This way, when you press a recipe group button and press start, that recipe will start cooking without searching for the recipe number. Recipe numbers can be set up as "quick recipes" as follows:

1. Press and hold both the TIME button and the knob for 5 seconds to get into the menu.
 2. Turn the knob to "RBTN" and press the knob. The word "PUSH" will flash.
 3. Press one of the recipe group buttons to assign a recipe.
- Note:** Recipe numbers 1-6 can be set up as Group button 1.
 Recipe numbers 7-12 can be set up as Group button 2.
 Recipe numbers 13-18 can be set up as Group button 3.
4. Turn the knob to the recipe number you want to assign to that button and press the knob.

Repeat the process to assign recipes to the other two recipe group buttons; or, turn the knob to "END" the submenu; turn to "END" the menu.

Additional Menu Settings:

Press and hold both the TIME button and the knob for 5 seconds to get into the menu.

Here you can set the recipes, quick recipes, temperature units (°C or °F) and the datalog settings (USB connection required):

"RECE" allows you to enable or disable the data record feature.

"RECF" allows you set how often (in minutes) a datapoint will be recorded.

"RECD" allows you to set how long (in days) you would like the data to be stored in memory.

MAINTENANCE INSTRUCTIONS HOW TO CLEAN THE UNIT

WARNING

BEFORE cleaning the cabinet:

1. **Unplug cord from wall. Allow cabinet to cool.**
2. **Do NOT hose cabinet with water.**
3. **Do NOT get water on controls.**
4. **Do NOT use abrasives or harsh chemicals.**
5. **Do NOT use “Cres Clean” (or any citrus cleaner) on labels or plastic parts.**

Cleaning Hints:

1. Use the mildest cleaning procedure that will do the job.
2. Always rub in the direction of the polish lines to avoid scratching the surface.
3. Use only a soft cloth, sponge, fibrous brushes, plastic or stainless steel pad for cleaning and scouring.
4. Rinse thoroughly with fresh water after every cleaning operation.
5. Always wipe dry to avoid water marks.

CARE & USE OF FOOD PROBES: DO'S & DON'TS

DO	DON'T
1. Sanitize (clean) the stainless steel probe after every use.	1. NEVER remove probe from a food product and place directly into new food items. Probe must be cleaned and sanitized before reuse.
2. Wipe clean with soapy, damp cloth. Rinse with clear water cloth.	2. DO NOT submerge the plastic handle, wires or connector/plug into water. Clean as instructed with soapy cloth and rinse with clean wet cloth.
3. Sterilize with food grade alcohol wipe prior to reuse in another food item.	3. NEVER pull on the wires to remove probe from food products or the oven receptacle. Always use the plastic handle or jack to insert and remove the probe from the foods and oven itself.
4. Pull/Remove the probe out of the food using the plastic handle only.	4. Take care NOT to catch or bend the probe in the door closure. The probe is a sensitive measuring device and should be replaced if damaged.
5. Designate a proper storage place for probes like the manager's office.	

Retherm Oven	FL-RO151030
Rev. 3 (7/13)	Page 7 of 11



MAINTENANCE INSTRUCTIONS TROUBLE-SHOOTING GUIDE, continued

HOW TO CLEAN THE UNIT:

	SOIL	CLEANER	METHOD
CABINET Inside and Outside (Stainless Steel)	ROUTINE CLEANING	Soap, ammonia or mild detergent* and water.	1. Sponge on with cloth 2. Rinse
	STUBBORN SPOTS, STAINS	Mild abrasive made for Stainless Steel.	1. Apply with damp sponge or cloth. 2. Rub lightly.
	BURNT ON FOODS OR GREASE	Chemical oven cleaner made for Stainless Steel.	Follow oven cleaner manufacturer's directions.
	HARD WATER SPOTS & SCALE	Vinegar	1. Swab or wipe with cloth. 2. Rinse and dry.
<i>* Mild detergents include soaps and non-abrasive cleaners</i>			

HOW TO ADJUST THE DOOR LATCH:

- | | |
|--|--|
| <ol style="list-style-type: none"> 1. For vertical (up and down movement) adjustment: <ol style="list-style-type: none"> a. Loosen (2) screws located in magnetic strike. b. Move strike up or down for alignment to magnet on latch. c. Tighten screws to secure | <ol style="list-style-type: none"> 2. For horizontal (greater or lesser magnetic draw) adjustment: <ol style="list-style-type: none"> a. Loosen (4) screws in door latch. b. Move latch forward or backward to adjust magnetism. c. Tighten screws to secure. |
|--|--|

TROUBLE-SHOOTING GUIDE



IF OVEN GETS TOO HOT OR WON'T SHUT OFF, DISCONNECT POWER AT BRANCH PANEL. DO NOT UNPLUG CORD!

If unit is *NOT* working, first check the following causes:

- | | |
|--|-----------------------------------|
| 1. Cord is unplugged from wall outlet. | 3. Switch is turned off. |
| 2. Circuit breaker/fuse to wall outlet is blown. | 4. Fuse on back of unit is blown. |

PROBLEM	POSSIBLE CAUSE	SOLUTION
Oven does not turn on	1. Power switch is bad 2. Retherm control is bad.	1. Replace 2. Replace

MAINTENANCE INSTRUCTIONS TROUBLE-SHOOTING GUIDE *(continued)*

IF THE OVEN TURNS ON:

PROBLEM	POSSIBLE CAUSE	SOLUTION
Oven does not heat, or doesn't heat properly	<ol style="list-style-type: none"> 1. Sensor 2. Heater contactor 3. Loose wiring at heater contactor 4. Retherm control 5. High Limit 	<ol style="list-style-type: none"> 1. Replace 2. Replace 3. Replace 4. Replace 5. Replace
Blowers do not operate	<ol style="list-style-type: none"> 1. Air retherm switch 2. Blower 3. Retherm control 	<ol style="list-style-type: none"> 1. Replace 2. Replace 3. Replace
Heater will not shut off	<ol style="list-style-type: none"> 1. Control defective 2. Heater contactor 	<ol style="list-style-type: none"> 1. Replace 2. Replace
Vent fans do not shut off	<ol style="list-style-type: none"> 1. Vent fan switch defective 2. Control compartment is still hot. 	<ol style="list-style-type: none"> 1. Replace 2. Wait until it cools Check "Heater will not shut off"
Vent fans do not operate (See Note)	<ol style="list-style-type: none"> 1. Vent fan switch defective 2. Vent fan defective 	<ol style="list-style-type: none"> 1. Replace 2. Replace
Control will not switch from "COOK" to "HOLD" (timed mode)	<ol style="list-style-type: none"> 1. Oven is in "PROBE" mode. 2. Retherm control defective 	<ol style="list-style-type: none"> 1. Cancel recipe and switch to "TIMED" mode 2. Replace
Control will not switch from "COOK" to "HOLD" (probe mode)	<ol style="list-style-type: none"> 1. Oven is in the "TIMED" mode 2. Probe not plugged in 3. Probe defective 4. Retherm control defective 	<ol style="list-style-type: none"> 1. Cancel recipe and switch to "PROBE" mode 2. Plug in probe 3. Replace 4. Replace
Control will not switch to "COOK" (probe mode)	<ol style="list-style-type: none"> 1. Oven in "TIMED" mode 2. Probe temperature setting lower than probe temperature 3. Probe not plugged in 4. Retherm control defective 	<ol style="list-style-type: none"> 1. Switch to "PROBE" mode 2. Set probe temperature to desired temperature 3. Plug in probe 4. Replace

ERROR CODES:

CODE DISPLAYED	CAUSE	SOLUTION
no p	No meat probe	Plug in probe
Err0	Temp probe bad	Replace

NOTE: Vent fans will not operate until the control compartment requires ventilation to limit temperatures. Replacement of electrical components must be done by a qualified electrician.

Refer to our *Service Agency list, FL-1400* (found in the back of this manual), of authorized service centers.

Instructions for replacing parts are included in replacement parts list.

Retherm Oven	FL-RO151030
Rev. 3 (7/13)	Page 9 of 11

REPLACEMENT PARTS
Include all information on nameplate when ordering parts

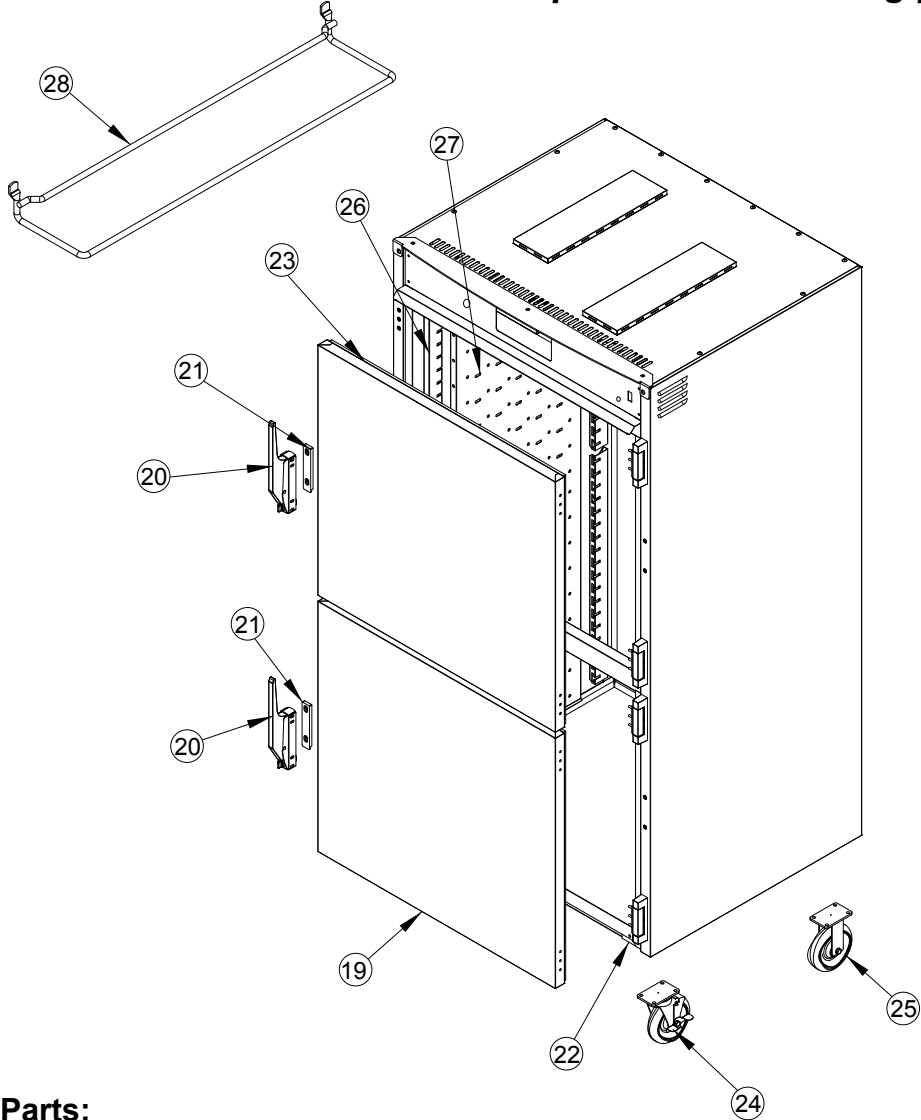

Replacement Parts:

ITEM DESCRIPTION	PART NUMBER
19. Door Assembly	1221-579-K
20. Door Latch Kit	1006-122-01-K
21. Door Strike Kit	1006-122-02-K
22. Door Hinge Kit	0519-109-K
23. Door Gasket	0861-235-K
24. Casters	0569-306-R
25. Casters w/brake	0569-306-BK
26. Posts	0696-250
27. Air Tunnel	0546-146-C
28. Wire Angles (2 per kit)	0621-281-K
Drip Pan (clear)	1017-058

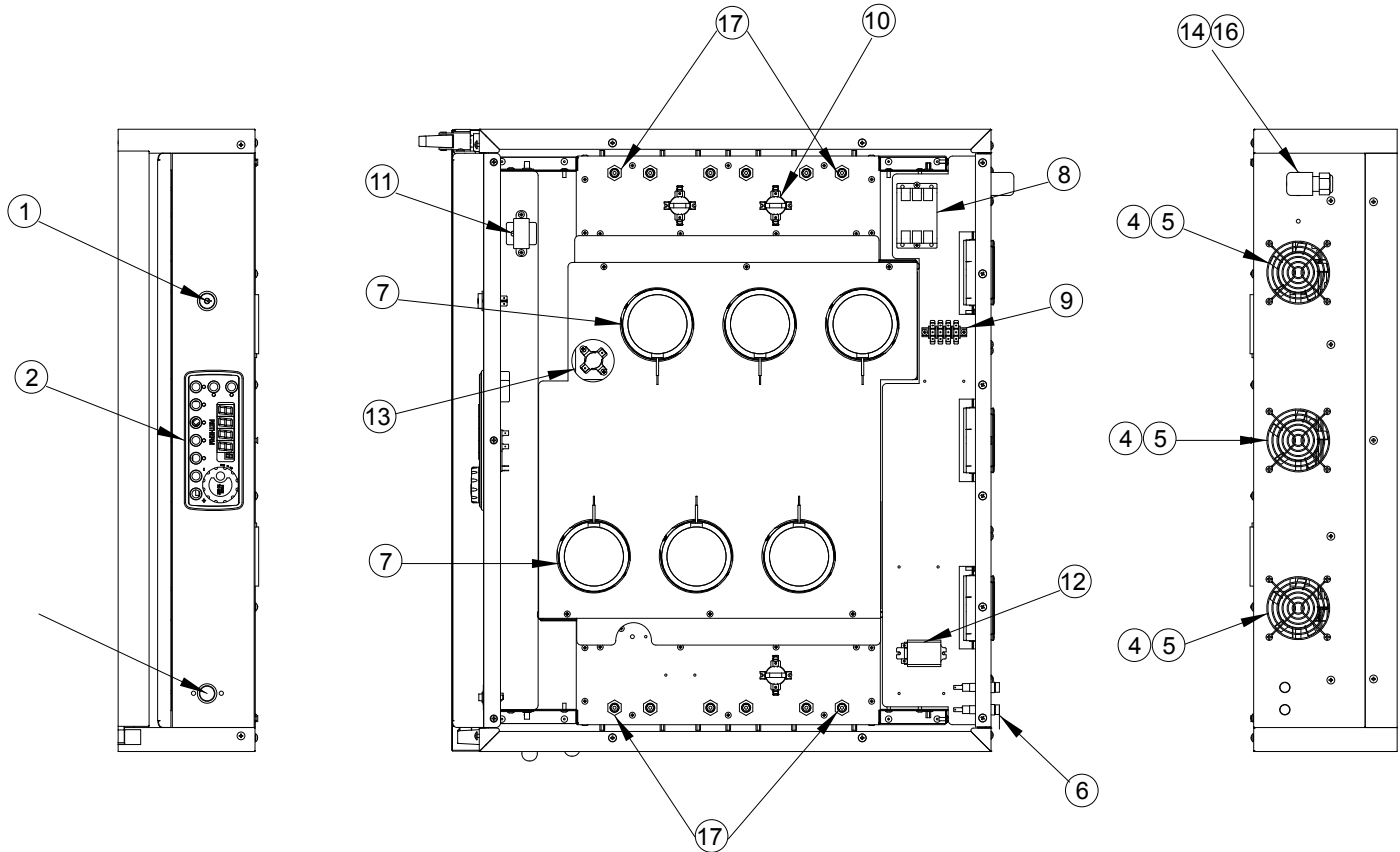

FRONT VIEW

**TOP VIEW
WITHOUT COVER**

REAR VIEW

Electrical Replacement Parts:

ITEM DESCRIPTION

1. Switch (On/Off)
2. Retherm Thermostat
Digital Control
Sensor
4. Vent Fan
5. Fan Guard
6. Fuse
Fuse Holder
7. Blower Kit
8. Contactor
9. Terminal Block, rear

Part No.

- 0808-125
0848-092-03-K
0848-091-K
0769-174
0769-167
0807-155
0807-150
0769-186-K
0857-026
0852-093

ITEM DESCRIPTION

10. Hi Limit Switch
11. Transformer
12. Relay
13. Fan Switch
14. Power Cord Kit
16. Strain Relief Kit
17. Heater Kit (208V)
Connector, Probe (not shown)
Food Probe 1.5" Long
Food Probe 6" Long

Part No.

- 0848-077
0769-197
0857-102
0848-034
0810-178-K
0818-103
0811-306
0848-094
0848-098
0848-100

Retherm Oven	FL-RO151030
Rev. 3 (7/13)	Page 11 of 11



5925 Heisley Road • Mentor, OH 44060-1833

REPLACEMENT PARTS

for NON-PASS THRU OVENS RO151F SERIES 208V, 1 Ph

Include all information
on nameplate when
ordering parts

