



Display Cases

Service and Installation Manual

Please read this manual completely before attempting to install or operate this equipment!
Notify carrier of damage! Inspect all components immediately. See page 2.



Model 724, 7000, and 9000 Series

CONTENTS

RECEIVING AND INSPECTING	3
INSTALLATION	3
WALL MOUNT INSTALLATION	4
WIRING DIAGRAMS	5
OPERATION	6
MAINTENANCE	6
REPLACEMENT PARTS	
7000 SERIES	7
MODEL 724	7
PIKE®-STYLE DOORS	8-9
9000 SERIES	10
TROUBLESHOOTING REFERENCE	11
STANDARD WARRANTIES	12-13
AUTHORIZED PARTS DEPOTS	back cover

SERIAL NUMBER LOCATION

724

Located on rear shroud panel below the power switches and thermostat.

7000 & 9000

Located on the inside light fixture on the right hand side.

Always have the serial number of your unit available when calling for parts or service. A complete list of authorized parts depots is shown on the back cover of this manual.

©2000 The Delfield Company. All rights reserved. Reproduction without written permission is prohibited.

"Delfield" is a registered trademarks of The Delfield Company.

SPECIFICATIONS

MODEL NUMBER	HFC-404A H.P.	HFC-404A REFRIGERANT	VOLTAGE/HERTZ/PHASE	HFC-404A AMPS	NEMA PLUG	SHIP WEIGHT	DELFIELD PART #
Show 'n' sell display cases							
7048-M	1/4	9.5 oz.	115/60/1	9.0	5-15P	284 lbs.	0722600
7048-P	1/4	9.5 oz.	115/60/1	9.0	5-15P	292 lbs.	0722700
7048-S	1/4	9.5 oz.	115/60/1	9.0	5-15P	282 lbs.	0722800
Premier refrigerated display cases							
9036	1/5	7.5 oz.	115/60/1	6.0	5-15P	188 lbs.	0722900
9048	1/5	7.5 oz.	115/60/1	6.0	5-15P	220 lbs.	0723000
9060	1/4	8.5 oz.	115/60/1	8.5	5-15P	276 lbs.	0723100
9072	1/4	8.5 oz.	115/60/1	8.5	5-15P	316 lbs.	0723200
Premier non-refrigerated display cases							
9336	—	—	115/60/1	2.5	5-15P	146 lbs.	0723300
9348	—	—	115/60/1	2.5	5-15P	172 lbs.	0723400
9360	—	—	115/60/1	2.5	5-15P	214 lbs.	0723500
9372	—	—	115/60/1	2.5	5-15P	240 lbs.	0723600
Compact counter-top display cases							
724	1/5	7.0 oz.	115/60/1	6.0	5-15P	110 lbs.	0780724

RECEIVING AND INSPECTING THE EQUIPMENT

Even though most equipment is shipped crated, care should be taken during unloading so the equipment is not damaged while being moved into the building.

Carefully check for any visible signs of damage to the cartons or containers. If evidence of damage exists, the package should be opened immediately and a joint inventory and examination of the contents should be made by you and the driver. Sign delivery receipt as damaged. Example— if (2) pieces of (5) are damaged, you must indicate the number of units damaged.

Concealed damage

If a concealed loss or damage is discovered after you have given the carrier a clear delivery receipt, **notify the carrier in writing immediately or within 10 days from the delivery**

date. If you phone the carrier, you must follow up the call in writing to protect your rights. You can only improve your position as a claimant by promptly reporting such loss or damage. You should also **retain all cartons or containers, including packing material**, until an inspection has been made or waived.

Filing a claim

Notation of loss or damage does not constitute the filing of a claim. You should file your claim **in writing** with the carrier immediately!

Carriers will furnish the necessary form upon request. You should also request an inspection. If a claim is filed by phone, always follow up immediately in writing.

INSTALLATION

Location

Delfield 7000 and 9000 Series and Model 724 display cases should be installed on a level surface away from any source of intense heat such as ovens or ranges. Do not install 9000 Series units closer than 6" (15.2 cm) from the ceiling or counter. This will allow air flow to the machine compartment. The 724 should be installed on legs as provided (4" [10.2 cm] from the counter).

When using a Model 724 display case, never obstruct the flow of air to the top of the cabinet. Do not place or store any items on top surface of unit. Obstruction of air may cause damage to the compressor.

On 7000 Series pass-through or see-through units, the cabinet can be installed with the machine compartment side flush against a wall or obstruction as long as both the front and the rear louvers are unobstructed. Do not install 7000 Series mirrored units closer than 6" (15.2 cm) from the wall.

If installing a 7000 Series display case into a counter-top, you must seal the perimeter of the equipment with silicone sealant (see diagram below).

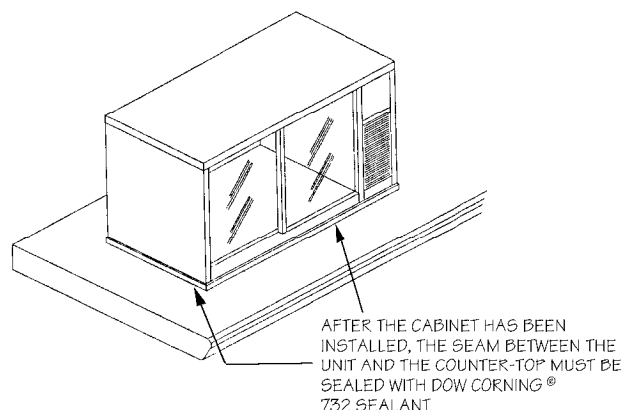

For the most efficient refrigeration, be sure to provide good air circulation inside and out. Take care not to block air flow to the fans and allow space along the sides.

Do not pack the interior of the display case so full that air cannot circulate.

Leveling

A level cabinet looks better and will perform better because the doors will line up with the door frames properly, and the cabinet will not be subject to unnecessary strain.

Electrical connection



Refer to the amperage data on page 2 or the serial tag data and your local code or the National Electrical Code to be sure the unit is connected to the proper power source. A protected circuit of the correct voltage and amperage must be run for connection of the line cord or permanent connection to the unit.

The power should be disconnected whenever performing maintenance or repair functions. Failure to observe this warning may result in electrical shock and personal injury!

WALL MOUNT INSTALLATION

7000 Series

The optional wall mount kit is designed to securely hold a 7000 Series unit to a structurally sound wall. It meets the requirements as established by Underwriter's Laboratories of withstanding a static load of four times the weight of the cabinet alone.



The Delfield Company cannot assume any responsibility for damage to a wall or injury of any persons should the wall fail as a result of the unit's weight. Nor will The Delfield Company assume any responsibility for damage or injury as a result of the wall mount fixture failing if it is determined that the installation instructions were not properly followed.

List of materials

- 2 — 2" x 2" x 3/16" (5.1 cm x 5.1 cm x 0.2 cm) angled aluminum brackets, 48" (121.9 cm) long
- 12 — #10 x 7/8" type A hex head metal screws
- 6 — 1/4" x 2-1/2" lag bolts
- 2 — stainless steel trim pieces



- 1 Position the prepunched aluminum bracket on the top of the unit, flush with the back edge, and mark the location of the holes on the unit. There should be one hole approximately 5/8" (1.6 cm) from each end of the cabinet, and a third hole 8.75" (22.2 cm) from the right end of the cabinet. Be sure to use the prepunched holes; screws in these locations tie into the internal support structure of the unit.
- 2 Drill 9/64" (3.6 mm) holes at the locations as marked. Attach the bracket to the unit with three of the #10 sheet metal screws.
- 3 Mount the bottom bracket to the wall.

On a stud wall, the bottom bracket should be screwed into a minimum of three studs with the provided 1/4" x 2-1/2" lag bolts. On a masonry block wall, the bottom bracket should be screwed into the wall at a minimum of three evenly spaced locations with 1/4" diameter toggle bolts (not provided).

When positioning the bottom bracket, be sure to allow at least 6" (15.2 cm) of clearance above and below the unit. Be sure the bottom bracket is level before continuing.

- 4 Position the unit on the bottom bracket and attach the top bracket to the wall using the same method as in step 3.
- 5 Attach the bottom bracket to the unit using the prepunched holes and three of the #10 sheet metal screws.

- 6 Attach the stainless steel trim strips to the left and right sides of the cabinet using three #10 metal screws on each side.

9000 Series



The Delfield Company cannot assume any responsibility for damage to a wall or injury of any persons should the wall fail as a result of the unit's weight. Nor will The Delfield Company assume any responsibility for damage or injury as a result of the wall brackets failing if it is determined that the installation instructions were not properly followed.

When choosing a location to mount your 9000 Series display case, keep in mind that the entire unit must be removed from the wall in order to clean the condenser. This must be done on a regular basis, in most cases not longer than every three months. Install the equipment in a location that will allow easy removal for cleaning.



- 1 Two wall brackets are supplied with 36" and 48" long units; three brackets are supplied with 60" and 72" long units. Lag bolts are not supplied (see below for recommended sizes). Use all brackets provided for a secure installation.

On a stud wall, the brackets should be screwed into two studs with 1/4" lag bolts so that 2.50" (6.4 cm) of the lag bolt engages the stud. On a masonry block wall, the brackets should be screwed into the wall at two evenly spaced locations with 1/4" diameter toggle bolts.

When positioning the brackets, be sure to allow at least 6" (15.2 cm) of clearance above and below the unit.

- 2 After the brackets are attached to the wall with one bolt in each, check that they are level. Finish mounting the brackets.
- 3 Once the brackets are secure, lift the unit into place and engage the angle bracket on the back of the unit into the wall brackets.

**WIRING DIAGRAM—
MODEL 724**

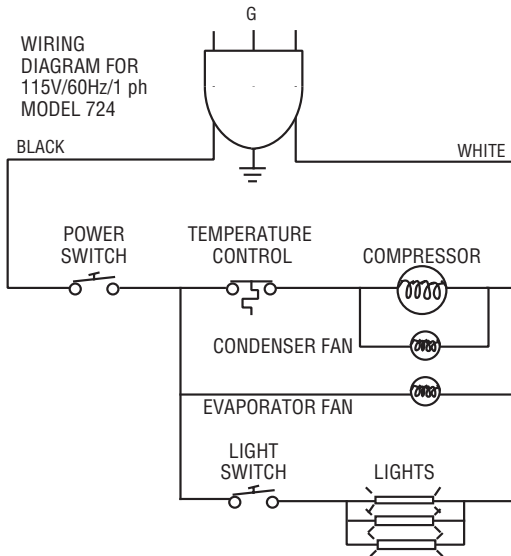

**WIRING DIAGRAM—
9000 SERIES**

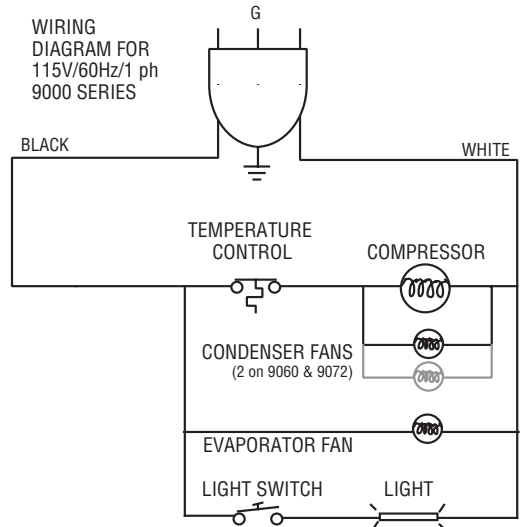

WIRING DIAGRAM—7000 SERIES

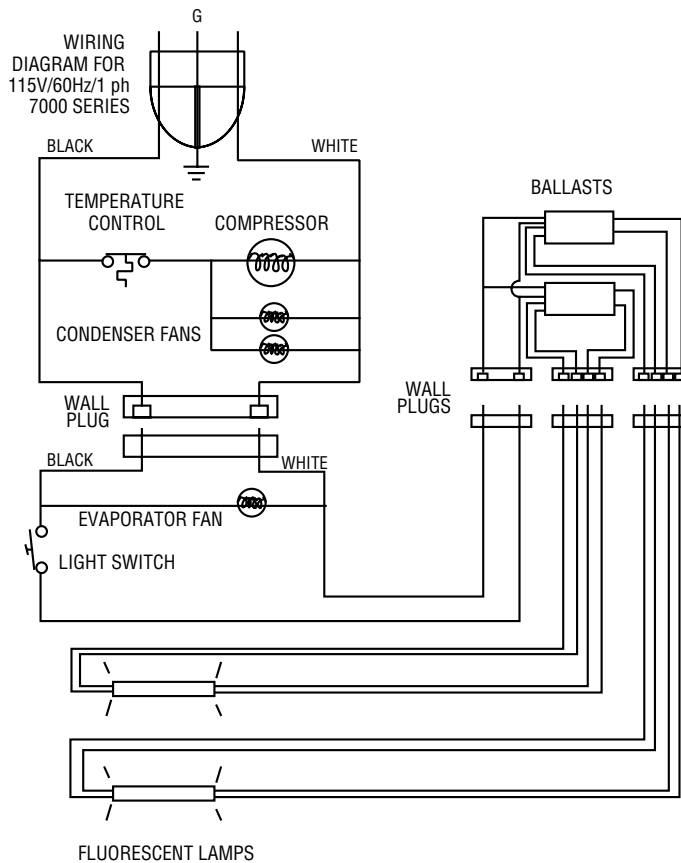

OPERATION

The units are self-defrosting. They do not require any manual defrosting. During normal operation, the coil will defrost automatically whenever the compressor is not operating.

In high humidity areas frost will accumulate on the coil, reducing the heat transfer that takes place. When this occurs, the system is designed to sense the frost build-up and shut off the compressor, thereby allowing it to defrost. Under these conditions, cabinet temperatures may be warmer than normal. This is not cause for alarm, but merely indicative of a properly functioning unit in high humidity conditions.

The unit is set at the factory to maintain between 36°F to 40°F (2°C to 4°C) and should require no adjustments on initial start-up. If temperatures are not satisfactory adjust the

temperature control. Turning the knob clockwise will make the cabinet colder.

The temperature control on the 9000 Series is located inside the cabinet near the top.

The temperature control on the 7000 Series is located behind the front louvered panel.

The temperature control on Model 724 units is on the back of the unit in the top left hand corner.

Model 724 units have a main switch that shuts off the entire unit. The light switch shuts off all three lights. The temperature control will shut off the condensing unit.

MAINTENANCE

Cleaning the unit

The interior and exterior can be cleaned using soap and warm water. If this is not sufficient try ammonia and water or a non-abrasive liquid cleaner.

When cleaning the exterior, always rub with the “grain” of the stainless steel to avoid marring the finish. Do not use an abrasive cleaner because it will scratch the stainless steel and plastic.

The sign insert on Model 724 units is easily removable for cleaning or replacement:



- 1 Remove the screws that attach the perforated top to the unit.
- 2 Lift off the perforated top and set it aside.
- 3 Facing the front of the unit, grasp the sign securely and lift it up and out of the “U”-shaped channel that holds it in place.
- 4 Clean with a mild soap and warm water, and allow the sign to dry thoroughly.
- 5 Reinsert the sign into the “U”-shaped channel.
- 6 Re-attach the perforated top with the screws.

Doors

To remove the Pike®-style doors on the 7000 and 9000 Series, follow these steps:



- 1 Open the right-hand (outer) sliding door about 2" to 4" (5 cm to 10 cm).
- 2 Lift the door vertically far enough to clear the bottom track.
- 3 Pull the door towards you and remove it.
- 4 Repeat steps 1 through 3 for the left-hand (inner) door.

Condensing unit



The power must be disconnected before doing any maintenance to the condensing unit. Failure to observe this warning may result in electrical shock and personal injury.

In order to maintain proper refrigeration performance, the condenser fins must be cleaned of dust, dirt, and grease regularly. It is recommended that this be done at least every three months. If conditions are such that the condenser is totally blocked in three months, the frequency of cleaning should be increased.

Clean the condenser with a vacuum cleaner or stiff brush. If extremely dirty a commercially available condenser cleaner may be required.

Door gaskets

The door gaskets should be cleaned as required to maintain their ability to seal properly. Do not use sharp tools or knives to scrape the bellows as this may tear the gasket and eliminate its ability to seal. A soft bristle brush and solution of soap and water should be all that is required to keep the gaskets clean. Do not use full strength de-greasing agents on the gasket as they could cause the gasket to crack and become brittle.

To help prevent the blower coil from becoming corroded, store all acidic items in sealed containers, and immediately wipe up all spills.

REPLACEMENT PARTS—MODEL 724 (HFC-404A)

The following replacement parts are for use with Model 724 units using HFC-404A refrigerant only.

Ballast	219-4161
Bracket assembly, fan, cond.	033-0146
Capillary tubing (84" of .044)	007-4100
Compressor, 1/5 h.p., 404A	352-6875
Coil, condenser	351-6241
Coil, evaporator.....	351-6240
Door assembly, hinged glass, left	323-4686
Door assembly, hinged glass, right.....	323-4673
Evaporator, hot gas	005-3565
Fan blade, 5.5".....	351-6289
Fan motor, 120V	216-2697
Heat exchanger	034-0242
Hinge, bottom of door.....	323-4687
Hinge, top of door.....	323-4688
Housing, evaporator.....	034-0226
Lamp, fluorescent, 18", F15T8/D (coated).....	219-4290
Lamp holder, left.....	219-3939
Lamp holder, right.....	219-3940
Leg, chrome plated, 4"	323-4685
Pan, condensate.....	005-5200
Pan, drain, plastic	170-2247
Pigtail, light fixture, 18".....	218-3410
Screen, intake	397-7989
Screw, wing, almond.....	932-1009
Shelf, almond.....	397-7990
Sign, "Beverage"	170-1037
Sign, blank	170-1035
Sign, "Fresh 'n' Cool"	170-1038
Sign, "Salad"	170-1039
Sign, "Sandwich"	170-1036
Switch, ON/OFF rocker.....	219-0154
Temperature control.....	219-4224
Thermometer, 4"	351-6135
Gasket.....	170-1215

REPLACEMENT PARTS— 7000 SERIES (HFC-404A)

The following replacement parts are for use with 7000 Series units using HFC-404A refrigerant only.

Accumulator, vertical, 4"	351-6186
Air diffuser	005-4638
Ballast	219-3998
Bearing, Pike®-style doors	see page 8
Capillary tube (96" of .044)	007-4061
Coil, condenser	351-6259
Coil, evaporator.....	351-6260
Compressor, 1/4 hp., 404A	352-6877
Door assembly, complete.....	345-5450
End panel, stainless steel	005-6510
Evaporator, hot gas	005-3542
Fan assembly, condenser.....	038-0316
Fan blade, condenser	351-6172
Fan blade, evaporator.....	351-6172
Fan guard, evaporator	351-6173
Fan motor, condenser	216-2691
Fan motor, evaporator.....	216-2691
Fluorescent bulb, 36"	219-4359
Glass, rear, 7048-S	345-5456
Lamp holder.....	219-4061
Legs (optional).....	323-4394
Louver, machine compartment front.....	005-6536
Mirror.....	345-5421
Shelf Beige.....	397-8054
Temperature control.....	219-4224
Top, stainless steel.....	005-6537
Trim, label, name plate	323-4120
Wall mount kit.....	038-0123
Thermometer, 4"	351-6135

For individual replacement parts for Pike®-style doors, see page 8.

Parts lists cover current models only. Contact Delfield for units using other refrigerants. • Before any labor to be done under warranty is performed, be sure the service agent has obtained a Delfield Service Work Authorization Number.

REPLACEMENT PARTS — PIKE® STYLE DOORS

7048-M/7048-P/7048-S

Complete door assembly	345-5450
1. Bearing, roller, single (2 per door)	323-4636
2. Gasket, bumper, 9 9/16"	323-3927
3. Gasket, wiper strip, 18 1/8"	323-3935
4. Spring, 15" green	323-3948
5. Track, bottom, 37 5/8"	323-3901
6. Track, top, 37 5/8"	323-3914

9036

Complete door assembly	345-5452
1. Bearing, roller, single (2 per door)	323-4636
2. Gasket, bumper, 15 1/8"	323-3926
3. Gasket, wiper strip, 13 11/16"	323-3934
4. Spring, 12" Green	323-3947
5. Track, bottom, 32"	323-3900
6. Track, top, 33"	323-3913

9060

Complete door assembly	345-5454
1. Bearing, roller, single, (2 per door)	323-4636
2. Gasket, bumper, 15 1/8"	323-3926
3. Gasket, wiper strip, 13 11/16"	323-3934
4. Spring, 23" green	323-3950
5. Track, bottom, 56"	323-3908
6. Track, top, 57"	323-3921

9048

Complete door assembly	345-5453
1. Bearing, roller, single (2 per door)	323-4636
2. Gasket, bumper, 15 1/8"	323-3926
3. Gasket, wiper strip, 13 11/16"	323-3934
4. Spring, 19" green	323-3949
5. Track, bottom, 44"	323-3903
6. Track, top, 45"	323-3916

9072

Complete door assembly	345-5455
1. Bearing, roller, single, (2 per door)	323-4636
2. Gasket, bumper, 15 1/8"	323-3926
3. Gasket, wiper strip, 55 3/8"	323-3941
4. Spring, 30" gold	323-3946
5. Track, bottom, 68"	323-3911
6. Track, top, 69"	323-3924

Parts lists cover current models only. Contact Delfield for units using other refrigerants. • Before any labor to be done under warranty is performed, be sure the service agent has obtained a Delfield Service Work Authorization Number.

REPLACEMENT PARTS—PIKE®-STYLE DOORS

All Delfield 7000 and 9000 Series display cases feature easily-removable doors manufactured by Pike®. These doors allow simple cleaning and maintenance, as well as easier replacement if the glass is cracked or broken.

Individual replacement parts for these Pike-style doors are

not stocked at the Delfield Authorized Parts Depots. They must be obtained directly from Delfield. Use the diagram below to identify the part you need (see page 8 for parts listing). Then call Delfield Customer Service at (800) 733-8829 with the model and serial number of your equipment.

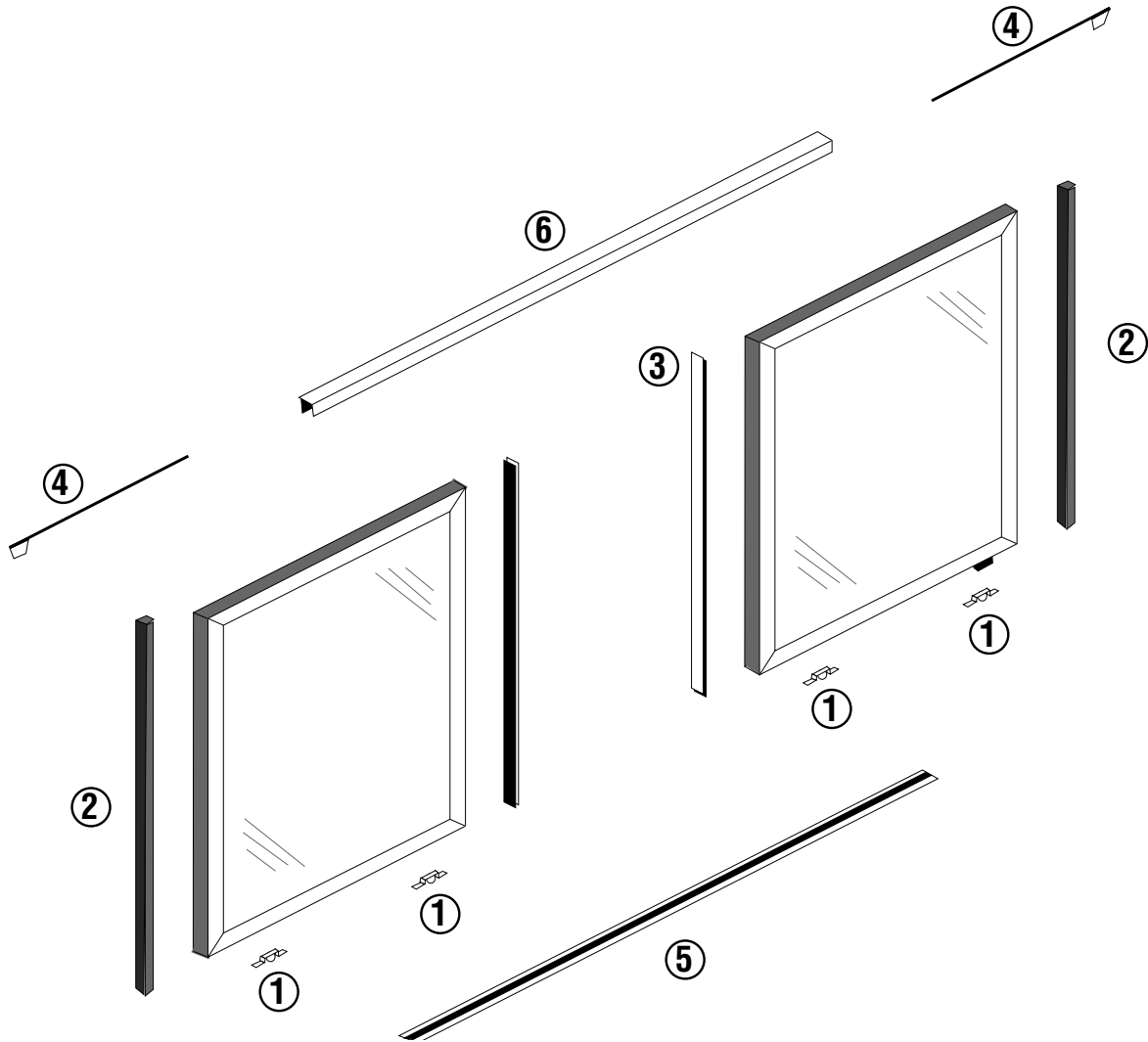

REPLACEMENT PARTS — 9000 SERIES (HFC-404A)

The following replacement parts are for use with 9000 Series units using HFC-404A refrigerant only.

	9036	9048	9060	9072
Accumulator..... 351-6051	X	X	X	X
Ballast 219-3998		X	X	X
Ballast 219-4161	X			
Bracket, mounting, condensing fan motor 038-2055	X	X	X	X
Bracket, mounting, evaporator fan motor 397-8060	X	X	X	X
Bracket, wall mount 005-1232	X	X	X	X
Capillary tube (132" of .044)	X	X		
Capillary tube (96" of .044)			X	X
Coil, condenser 351-6263	X	X		
Coil, condenser 351-6264			X	X
Coil, evaporator..... 351-6261	X	X		
Coil, evaporator..... 351-6262			X	X
Compressor, 1/4 h.p., 404A 352-6877			X	X
Compressor, 1/5 h.p., 404A 352-6875	X	X		
Door assembly, Pike®-style complete 345-5452	X			
Door assembly, Pike®-style complete 345-5453		X		
Door assembly, Pike®-style complete 345-5454			X	
Door assembly, Pike®-style complete 345-5455				X
Fan blade, condenser 351-6274	X	X	X	X
Fan blade, evaporator..... 216-2500	X	X	X	X
Fan guard, condenser 351-6178	X	X	X	X
Fan guard, evaporator..... 351-6185	X	X	X	X
Fan motor, condenser 216-2691	X	X	X	X
Fan motor, evaporator..... 216-2667	X	X	X	X
Fluorescent bulb, 24", F20T12..... 219-4054	X			
Fluorescent bulb, 36", F30T8..... 219-4359		X		
Fluorescent bulb, 48", F40T12..... 219-4052			X	X
Mirror, 36"..... 345-5350	X			
Mirror, 48"..... 345-5351		X		
Mirror, 60"..... 345-5352			X	
Mirror, 72"..... 345-5353				X
Shelf, 36", beige 9.87" X 32" 397-8000	X			
Shelf, 48", beige 9.87" X 44" 397-8001		X		
Shelf, 60", beige 9.87" X 56" 397-8002			X	
Shelf, 72", beige 9.89" X 68" 397-8003				X
Temperature control..... 219-4224	X	X	X	X
Thermometer, 4" 351-6135	X	X	X	X

For individual replacement parts for Pike®-style doors, see page 11.

Parts lists cover current models only. Contact Delfield for units using other refrigerants. • Before any labor to be done under warranty is performed, be sure the service agent has obtained a Delfield Service Work Authorization Number.

Standard One Year Warranty (one year parts, 90 days labor)

The Delfield Company ("Delfield") warrants to the Original Purchaser of the Delfield product (herein called the "Unit") that such Unit, and all parts thereof, will be free from defects in material and workmanship under normal use and service for a period of one (1) year from the date of shipment of the Unit to the Original Purchaser **or, if the Original Purchaser returns the warranty card completely filled out including the date of installation within thirty (30) days of receipt of the Unit, one (1) year from the date of installation.** During this one year warranty period, Delfield will repair or replace any defective part or portion thereof returned to Delfield by the Original Purchaser which Delfield determines was defective due to faulty material or workmanship. The Original purchaser will pay all labor, crating, freight and related costs incurred in the removal of the Unit of defective component and shipment to Delfield, except that during a period of either ninety (90) days from the date of shipment of the Unit to the Original Purchaser or, if the Original Purchaser returns the warranty card completely filled out including the date of installation within thirty (30) days of receipt of the Unit, ninety (90) days from the date of installation Delfield will pay all related labor costs. Delfield will pay the return costs if the Unit or part thereof was defective.

The term "Original Purchaser" as used herein means that person, firm, association, or corporation for whom the Unit was originally installed.

This warranty does not apply to any Unit or part thereof that has been subjected to misuse, neglect, alteration, or accident, such as accidental damage to the exterior finish, operated contrary to the recommendations specified by Delfield; or repaired or altered by anyone other than Delfield in any way so as to, in Delfield's sole judgement, affect its quality or efficiency. This warranty does not apply to any Unit that has been moved from the location where it was originally installed. This warranty also does not cover the refrigerator drier or the light bulbs used in the Unit. **The warranty is subject to the user's normal maintenance and care responsibility as set forth in the Service and Installation Manual, such as cleaning the condenser coil, and is in lieu of all other obligations of Delfield. Delfield neither assumes, nor authorizes any other person to assume for Delfield, any other liability in connection with Delfield's products.**

Removal or defacement of the original Serial Number or Model Number from any Unit shall be deemed to release Delfield from all obligations hereunder or any other obligations, express or implied.

Parts furnished by suppliers to Delfield are guaranteed by Delfield only to the extent of the original manufacturer's express warranty to Delfield. Failure of the Original Purchaser to receive such manufacturer's express warranty to Delfield. Failure of the Original Purchaser to receive such manufacturer's warranty shall in no way create any warranty, expressed or implied, or any other obligation or liability on Delfield's part in respect thereof.

If shipment of a replacement part is requested prior to the arrival in the Delfield factory of the part claimed to be defective, the Original Purchaser must accept delivery of the replacement part of a C.O.D. basis, with credit being issued after the part has been received and inspected at Delfield's plant and determined by Delfield to be within this warranty.

Under no condition does this warranty give the Original Purchaser the right to replace the defective Unit with a complete Unit of the same manufacturer or of another make. Unless authorized by Delfield in writing, this warranty does not permit the replacement of any part, including the motor-compressor, to be made with the part of another make or manufacturer.

No claims can be made under this warranty for spoilage of any products for any reason, including system failure.

The installation contractor shall be responsible for building access, entrance and field conditions to insure sufficient clearance to allow any hood(s), vent(s), or Unit(s) if necessary, to be brought into the building. Delfield will not be responsible for structural changes or damages incurred during installation of the Unit or any exhaust system.

Delfield shall not be liable in any manner for any default or delay in performance hereunder caused by or resulting from any contingency beyond Delfield's control, including, but not limited to, war, governmental restrictions or restraints, strike, lockouts, injunctions, fire, flood, acts of nature, short or reduced supply of raw materials, or discontinuance of the parts by the original part manufacturer.

Except as provided in any Additional Four Year Protection Plan, if applicable, and the Service Labor Contract, if applicable, the foregoing is exclusive and in lieu of all other warranties, whether written or oral, express or implied. This warranty supersedes and excludes any prior oral or written representations or warranties. Delfield expressly disclaims any implied warranties of merchantability, fitness for a particular purpose of compliance with any law, treaty, rule or regulation relating to the discharge of substances into the environment. The sole and exclusive remedies of any person relating to the Unit, and the full liability of Delfield for any breach of this warranty, will be as provided in this warranty.

Other than this Delfield Standard One Year Limited Warranty, any applicable Delfield Additional Four Year Protection Plan or applicable Delfield Service Labor Contract, the Original Purchaser agrees and acknowledges that no other warranties are offered or provided in connection with or for the unit or any other part thereof.

In no event will Delfield be liable for special, incidental or consequential damages, or for damages in the nature of penalties.

Additional Four Year Protection Plan (for Motor-Compressors only)

Delfield Model#	Serial #	Installation Date

In addition to the Standard One Year Warranty on the Motor-Compressor contained in the above listed Delfield product (the "Unit"), The Delfield Company ("Delfield") also agrees to repair, or exchange with similar or interchangeable parts in design and capacity at Delfield's option, the defective Motor-Compressor contained in the Unit (the "Motor-Compressor"), or any part thereof, for the Original Purchaser only, at any time during the four (4) years following the initial one (1) year period commencing on the date of installation for the Original Purchaser. **Failure of the Original Purchaser to register the registration card containing the Original Purchasers name, address, date of installation, model number and serial number of the Unit containing the Motor-Compressor within 30 days from the date of installation shall void this warranty.** This additional warranty is only available if the Motor-Compressor is inoperative due to defects in material or factory workmanship, as determined by Delfield in its sole judgement and discretion. The Original Purchaser shall be responsible for returning the defective Motor-Compressor to Delfield prepaid, F.O.B. at the address shown on the back cover of this manual.

The term "Original Purchaser" as used herein means that person, firm, association, or corporation for whom the Unit was originally installed.

The term "Motor-Compressor" as used herein does not include unit base, air or water cooled condenser, receiver, electrical accessories such as relay, capacitors, refrigerant controls, or condenser fan/motor assembly. This warranty does not cover labor charges incidental to the replacement of parts. This warranty further does not include any equipment to which said condensing unit is connected, such as cooling coils, temperature controls or refrigerant metering devices. This warranty shall be void if the Motor-Compressor, in Delfield's sole judgement, has been subjected to misuse, neglect, alteration or accident, operated contrary to the recommendations specified by the Unit manufacturer, repaired or altered by anyone other than Delfield in any way so as, in Delfield's sole judgment, to affect its quality or efficiency or if the serial number has been altered, defaced or removed. This Warranty does not apply to a Motor-Compressor in any Unit that has been moved from the location where it was originally installed. The addition of methyl chloride to the condensing unit or refrigeration system shall void this warranty.

General Conditions

Delfield shall not be liable in any manner for any default or delay in performance hereunder caused by or resulting from any contingency beyond Delfield's control, including, but not limited to, war, governmental restrictions or restraints, strike, lockouts, injunctions, fire, flood, acts of nature, short or reduced supply of raw materials, or discontinuance of any part or the Motor-Compressor by the unit manufacturer.

Replacement of a defective Motor-Compressor is limited to one (1) Motor-Compressor by us during the four (4) year period. Delfield shall replace the Motor-Compressor at no charge.

This warranty does not give the Original Purchaser of the Motor-Compressor the right to purchase a complete replacement Motor-Compressor of the same make or of another make. It further does not permit the replacement to be made with a Motor-Compressor of another kind unless authorized by Delfield. In the event Delfield authorizes the Original Purchaser to purchase a replacement Motor-Compressor locally, only the wholesale cost of the Motor-Compressor is refundable.

Expressly excluded from this warranty are damages resulting from spoilage of goods.

Except as provided in any applicable Standard One Year Limited Warranty or applicable Service Labor Contract, the foregoing is exclusive and in lieu of all other warranties, whether written or oral, express or implied. This Warranty supersedes and excludes any prior oral or written representations or warranties. Delfield expressly disclaims any implied warranties of merchantability, fitness for a particular purpose or compliance with any law, treaty, rule or regulation relating to the Motor-Compressor, and the full liability of Delfield for any breach of this warranty, will be as provided in this warranty.

Other than any applicable Delfield Standard One year Limited Warranty, this Delfield Additional Four Year Protection Plan and any applicable Delfield Service Labor Contract, the Original Purchaser agrees and acknowledges that no other warranties are offered or provided in connection with or for the Motor-compressor or any part thereof.

In no event will Delfield be liable for special, incidental or consequential damages, or for damages in the nature of penalties.



NOTES

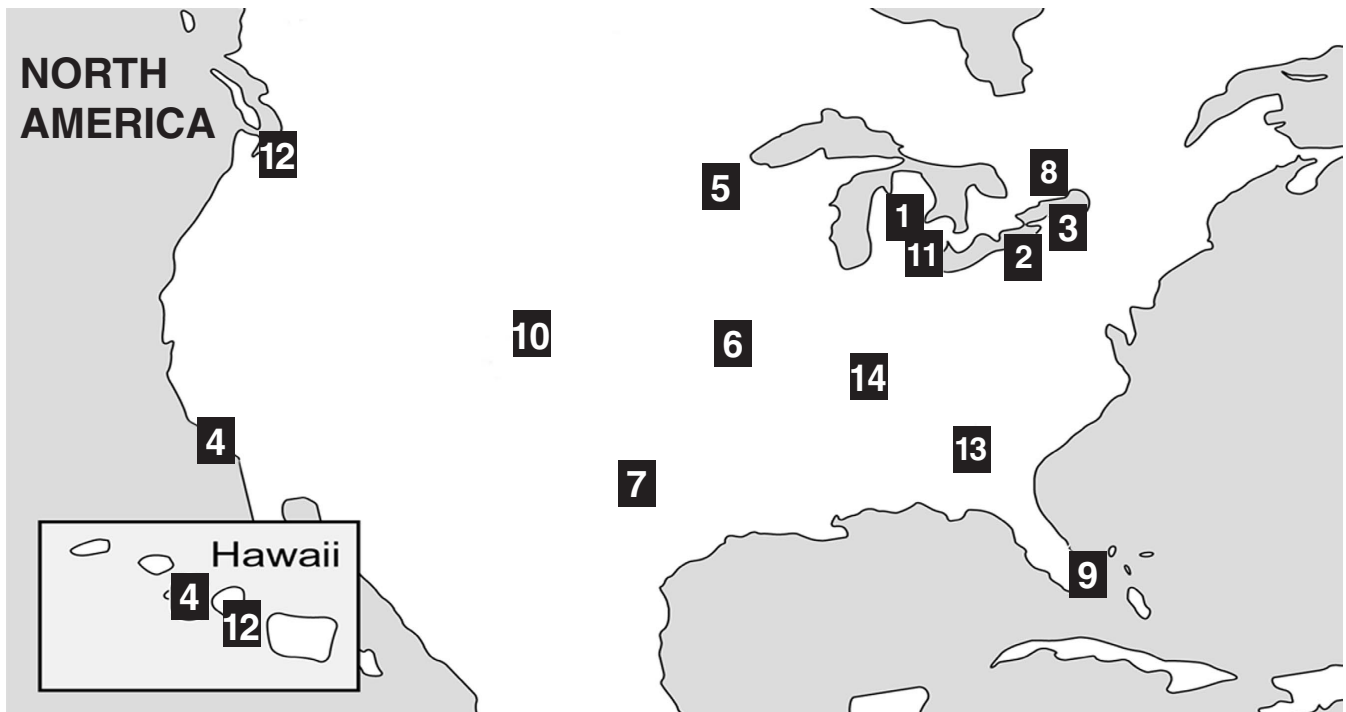

Delfield has 14 conveniently located Parts Depots to ensure parts are handled promptly and accurately.

<p>1) The Delfield Company</p> <p>980 South Isabella Road Mt. Pleasant, MI 48858 800.733.8829 989.773.7981 989.773.3210 FAX custom parts direct from Delfield</p>	<p>2) A.I.S. Commercial Parts & Service</p> <p>1816 West 26th Street Erie, PA 16508-1149 800.332.3732 814.456.3732 814.452.4843 FAX serves: MD, NJ, OH, PA, VA, WV</p>	<p>3) Appliance Installation Service</p> <p>1336 Main Street Buffalo, NY 14209 800.722.1252 716.884.7425 716.884.0410 FAX serves: CT, DC, DE, MA, MD, ME, NH, NJ, NY, PA, RI, VA, VT, WV</p>	<p>4) Barker's Food Machinery</p> <p>5367 2nd Street Irwindale, CA 91706 800.258.6999 626.960.9390 626.337.4541 FAX serves: AZ, CA, HI, NV, OR</p>
<p>5) Contract Ice</p> <p>14450 Ewing Ave S. #100 Burnsville, MN 55306 800.422.2823 952.894.4427 952.894.2164 FAX serves: IA, MN, MT, ND, SD, WI</p>	<p>6) E.M.C.O. Sales & Distributors</p> <p>3909 St. Timothy Lane St. Ann, MO 63074 800.972.7670 314.427.7477 314.427.8190 FAX serves: AR, IA, IL, KS, KY, MO, NE, OK, TX, NM, LA</p>	<p>7) GCS SERVICE</p> <p>10850 Sanden Drive Dallas, TX 75238 1.800.442.5026 toll free 972.484.2954 local 214.340.2363 fax serves: AR, LA, NM, OK, TX</p>	<p>8) Garland Group</p> <p>1177 Kamato Road Mississauga, Ontario L4W1X4 800.427.6668 800.361.7745 FAX serves: Canada</p>
<p>9) Global Parts and Supplies</p> <p>2920 N.W. 109th Avenue Miami, FL 33172 305.994.9994 305.994.9992 FAX International parts depot</p>	<p>10) Hawkins Commercial Appl. Serv.</p> <p>3000 S. Wyandot Englewood, CO 80110 (800) 624-2117 (303) 7618861 FAX serves: AZ, CO, KS, NE, NM, OK, UT, WY</p>	<p>11) MicroDine, Inc.</p> <p>44792 Helm Plymouth, MI 48170 888.828.4454 734.451.2043 734.451.3215 FAX serves: MI, IN, WI, OH</p>	<p>12) Performance Refrigeration Parts</p> <p>9923 S.W. 178th St. Vashon, WA 98070 888.872.2465 206-463-1772 206.463.4431 FAX serves: AK, HI, ID, MT, OR, WA</p>
<p>13) Southeastern Restaurant Services</p> <p>2200 Norcross Parkway, Suite 210 Atlanta, GA 30071 800.235.6516 770.446.6177 770.446.3157 FAX serves: FL, GA, MS, NC, SC, VA</p>	<p>14) T.M.A.</p> <p>2916 Sidco Drive Nashville, TN 37204 615.726.0351 800.737.0351 615.259.4100 FAX serves: TN, AL</p>		



980 S. Isabella Rd., Mt. Pleasant, MI 48804-0470, U.S.A. • (989) 773-7981 or (800) 733-8821 • Fax (989) 773-3210 • www.delfield.com
Delfield reserves the right to make changes in design or specifications without prior notice. 2001 the Delfield company. All rights reserved. Printed in the U.S.A.