

# 18600 Series and CTP-NB

## Service and Installation Manual

Please read this manual completely before attempting to install or operate this equipment! **Notify carrier of damage!** Inspect all components immediately.



**18600PTL**  
Pizza Tables with LiquiTec® Rail



**18600PTBM**  
Pizza Tables with Raised Rail



**18600BUCM**  
Work Tables



**18600PDL**  
Dual LiquiTec® Rail Prep Table



**18600BSTM**  
Work Table with Backsplash



**CTP-NB**  
Countertop Condiment Rail



**Important Information**  
**Read Before Use**  
**Please Save These Instructions!**

May 2013

## Important Warning And Safety Information



WARNING

Read This Manual Thoroughly Before Operating, Installing, Or Performing Maintenance On The Equipment.



WARNING

Failure To Follow Instructions In This Manual Can Cause Property Damage, Injury Or Death.



WARNING

Do Not Store Or Use Gasoline Or Other Flammable Vapors Or Liquids In The Vicinity Of This Or Any Other Appliance.



WARNING

Unless All Cover And Access Panels Are In Place And Properly Secured, Do Not Operate This Equipment.



WARNING

This Appliance Is Not Intended For Use By Persons Who Lack Experience Or Knowledge, Unless They Have Been Given Supervision Or Instruction Concerning Use Of The Appliance By A Person Responsible For Their Safety.



WARNING

This Appliance Is Not To Be Played With.



WARNING

Do Not Clean With Water Jet.



WARNING

Do Not Use Electrical Appliances Inside The Food Storage Compartment Of This Appliance.



CAUTION

Observe the following:

- Minimum clearances must be maintained from all walls and combustible materials.
- Keep the equipment area free and clear of combustible material.
- Allow adequate clearance for air openings.
- Operate equipment only on the type of electricity indicated on the specification plate.
- Unplug the unit before making any repairs.
- Retain this manual for future reference.

## Contents

Receiving & Inspecting Equipment .....	3
Serial Number Information .....	4
Warranty Information.....	4
Regulatory Certifications.....	4
Specifications .....	5
Refrigerant Charges .....	6
Installation .....	6
Operation	
18600PTBM & PTL Series.....	7
18600BUCM & BSTM Series.....	7
18600PDL Series .....	8
CTP-NB Series .....	8
Pressure Control Settings.....	9
Temperature Control Settings .....	9
Care And Cleaning.....	10-11
Wiring Diagram	
18600PTBM & PTL Series.....	12
18600BUCM & BSTM Series.....	13
18600PDL .....	13
CTP-NB Series .....	14
Replacement Parts.....	15-24
Standard Labor Guidelines .....	25
Notes .....	26-27

## Receiving And Inspecting The Equipment

Even though most equipment is shipped crated, care should be taken during unloading so the equipment is not damaged while being moved into the building.

1. Visually inspect the exterior of the package and skid or container. Any damage should be noted and reported to the delivering carrier immediately.
2. If damaged, open and inspect the contents with the carrier.
3. In the event that the exterior is not damaged, yet upon opening, there is concealed damage to the equipment notify the carrier. Notification should be made verbally as well as in written form.
4. Request an inspection by the shipping company of the damaged equipment. This should be done within 10 days from receipt of the equipment.
5. Check the lower portion of the unit to be sure legs or casters are not bent.
6. Also open the compressor compartment housing and visually inspect the refrigeration package. Be sure lines are secure and base is still intact.
7. Freight carriers can supply the necessary damage forms upon request.
8. Retain all crating material until an inspection has been made or waived.

### Uncrating the Equipment

First cut and remove the banding from around the crate. Remove the front of the crate material, use of some tools will be required. If the unit is on legs remove the top of the crate and lift the unit off the skid. If the unit is on casters it can be "rolled" off the skid.

## Serial Number Information

The serial number on 18600 Series units is located on the electrical specifications tag affixed inside the compressor section next to the pressure control.

The serial number on CTP-NB Series units is located on the front of the unit.

Always have the serial number of your unit available when calling for parts or service.



**Warranty may be deemed invalid if other than authorized OEM (original equipment manufacture) replacement parts are used in Delfield equipment.**

©2013 The Delfield Company. All rights reserved. Reproduction without written permission is prohibited. "Delfield" is a registered trademark of The Delfield Company.

## Warranty Information

Visit [http://www.delfield.com/minisite/service/warranty\\_info](http://www.delfield.com/minisite/service/warranty_info) to:

- Register your product for warranty.
- Verify warranty information.
- View and download a copy of your warranty.

## Regulatory Certifications

Models are certified by:



**National Sanitation Foundation (NSF)**



**Underwriters Laboratories (UL)**

**Underwriters Laboratories of Canada (ULC)**

# Specifications

## 18600PTBM Pizza tables with raised rail

Model	1/3 Pan Size Capacity	# Of Doors	# Of Shelves	Shelf Max Load (LBS)	Shelf Area FT <sup>2</sup>	Volume FT <sup>3</sup>	BTU Load Base/Rail	BTU Sys. Cap. Base/Rail	H.P.	Voltz/Hertz/Phase	Amps	NEMA Plug	Ship Weight LBS/KG
18648PTBM	6	(1) 27"	1	124	3.95	10.23	470/441	2001/952	1/4	115/60/1	10.0	5-15P	520/236
18660PTBM	7	19" & 27"	2	70/124	6.51	15.12	694/617	2409/1208	1/3	115/60/1	12.0	5-15P	575/260
18672PTBM	9	(2) 27"	2	124	7.9	18.10	776/794	2967/1587	1/2	115/60/1	14.0	5-20P	635/288
18691PTBM	11	(2)27" & (1) 19"	3	124/70	10.29	24.48	1062/1058	3537/1865	1/2	115/60/1	14.0	5-20P	770/350
18699PTBM	12	(3) 27"	3	124	11.85	27.46	1144/1147	3537/1945	1/2	115/60/1	14.0	5-20P	805/365
186114PTBM	14	(3) 32"	3	140	14.46	33.05	1297/1323	5169/2433	3/4	115/60/1	16.0	5-20P	927/420

## 18600BUCM Work tables

Model	# Of Doors	# Of Shelves	Shelf Max Load (LBS)	Shelf Area FT <sup>2</sup>	Volume FT <sup>3</sup>	BTU Load Base/Rail	BTU Sys. Cap. Base/Rail	H.P.	Voltz/Hertz/Phase	Amps	NEMA Plug	Ship Weight LBS/KG
18648BUCM	(1) 27"	1	124	3.95	10.23	475/NA	1462/NA	1/5	115/60/1	8.0	5-15P	390/177
18660BUCM	19" & 27"	2	70/124	6.51	15.12	686/NA	1462/NA	1/5	115/60/1	8.0	5-15P	435/197
18672BUCM	(2) 27"	2	124	7.90	18.10	856/NA	2263/NA	1/4	115/60/1	10.0	5-15P	495/225
18691BUCM	(2)27" & (1) 19"	3	124/70	10.29	24.48	1169/NA	2263/NA	1/4	115/60/1	10.0	5-15P	535/243
18699BUCM	(3) 27"	3	124	11.85	27.46	1220/NA	2263/NA	1/4	115/60/1	10.0	5-15P	594/269
186114BUCM	(3) 32"	3	106	14.46	37.24	1373/NA	2813/NA	1/3	115/60/1	12.0	5-15P	685/310

## 18600BSTM Work table with backsplash

Model	# Of Doors	# Of Shelves	Shelf Max Load (LBS)	Shelf Area FT <sup>2</sup>	Volume FT <sup>3</sup>	BTU Load Base/Rail	BTU Sys. Cap. Base/Rail	H.P.	Voltz/Hertz/Phase	Amps	NEMA Plug	Ship Weight LBS/KG
18648BSTM	(1) 27"	1	124	3.95	10.23	475/NA	1462/NA	1/5	115/60/1	8.0	5-15P	390/177
18660BSTM	19" & 27"	2	70/124	6.51	15.12	686/NA	1462/NA	1/5	115/60/1	8.0	5-15P	435/197
18672BSTM	(2) 27"	2	124	7.90	18.10	856/NA	2261/NA	1/4	115/60/1	10.0	5-15P	495/225
18691BSTM	(2)27" & (1) 19"	3	124/70	10.29	24.48	1169/NA	2261/NA	1/4	115/60/1	10.0	5-15P	535/243
18699BSTM	(3) 27"	3	124	11.85	27.46	1220/NA	2591/NA	1/3	115/60/1	12.0	5-15P	594/269
186114BSTM	(3) 32"	3	106	14.46	37.24	1373/NA	2591/NA	1/3	115/60/1	12.0	5-15P	685/310

## 18600PTL Pizza table with LiquiTec® rail

Model	1/3 Pan Size Capacity	# Of Doors	# Of Shelves	Shelf Max Load (LBS)	Shelf Area FT <sup>2</sup>	Volume FT <sup>3</sup>	BTU Load Base/Rail	BTU Sys. Cap. Base/Rail	H.P.	Voltz/Hertz/Phase	Amps	NEMA Plug	Ship Weight LBS/KG
18648PTL	6	(1) 27"	1	124	3.95	10.23	470/441	2001/952	1/4	115/60/1	10.0	5-15P	520/236
18672PTL	9	(2) 27"	2	124	7.90	18.10	776/794	2967/1587	1/2	115/60/1	14.0	5-20P	635/288
18699PTL	12	(3) 27"	3	124	11.85	27.46	1144/1147	3537/1945	1/2	115/60/1	14.0	5-20P	805/365

## 18600PDL Pizza table with Dual LiquiTec® rails

Model	1/3 Pan Size Capacity	# Of Doors	# Of Shelves	Shelf Max Load (LBS)	Shelf Area FT <sup>2</sup>	Volume FT <sup>3</sup>	BTU Load Base/Rail	BTU Sys. Cap. Base/Rail	H.P.	Voltz/Hertz/Phase	Amps	NEMA Plug	Ship Weight LBS/KG
18648PDL	6	(1) 27"	1	124	3.95	10.23	424/1058	2001/1865	1/5, 1/3	115/60/1	10.1	5-20P	691/313
18672PDL	9	(2) 27"	2	124	7.90	18.10	703/1588	2001/3174	1/5, 1/2	115/60/1	12.7	5-20P	873/396

## CTP-NB Counter top containment rail

Model	1/3 Pan Size Capacity	# Of Adapter Bars	BTU Load	BTU System Capacity	H.P.	Voltz/Hertz/Phase	Amps	NEMA Plug	Ship Weight LBS/KG
CTP8146-NB	4	5	305	523	1/5	115/60/1	4.0	5-15P	121/54.9
CTP8160-NB	6	7	462	653	1/5	115/60/1	4.0	5-15P	158/71.7



## Refrigerant Charges



### Refrigerant Charges For 18600 Series Units:

18648-PTBM & PTL . . . . .	16 oz. (454g)	18660-BUCM & BSTM . . . . .	16 oz. (454g)
18660-PTBM . . . . .	24 oz. (680g)	18672-BUCM & BSTM . . . . .	16 oz. (454g)
18672-PTBM & PTL . . . . .	32 oz. (907g)	18691-BUCM & BSTM . . . . .	16 oz. (454g)
18691-PTBM . . . . .	32 oz. (907g)	18699-BUCM & BSTM . . . . .	24 oz. (680g)
18699-PTBM & PTL . . . . .	32 oz. (907g)	186114-BUCM & BSTM . . . . .	24 oz. (680g)
186114-PTBM . . . . .	48 oz. (1361g)	18648PDL . . . . .	40 oz. (1134g)
18648-BUCM & BSTM . . . . .	16 oz. (454g)	18672PDL . . . . .	56 oz. (1588g)



### Refrigerant Charges For CTP-NB Series Units:

CTP8146-NB . . . . .	8 oz. (227g)
CTP8160-NB . . . . .	8 oz. (227g)
CTP8175-NB . . . . .	16 oz. (454g)

## Installation

### Location

These units are intended for indoor use only. Be sure the location chosen has a floor strong enough to support the total weight of the cabinet and contents. A fully loaded 72" long model may weigh as much as 1200 pounds. Reinforce the floor as necessary to provide for maximum loading.

For the most efficient refrigeration, be sure to provide good air circulation inside and out.

**Inside cabinet:** Do not pack refrigerator so full that air cannot circulate.

**Outside cabinet:** Be sure that the unit has access to ample air. Avoid hot corners and locations near stoves and ovens.

It is recommended that the unit be installed no closer than 1" from any wall. PDL models also require 14" (36cm) clearance at the top and 6" (15cm) clearance at the bottom (casters).

### Leveling

A level cabinet looks better and will perform better because the drain pan will drain properly, the doors will line up with the frames properly, and the cabinet will not be subject to undue strain.

Some models have casters for your convenience, for ease of cleaning underneath and for mobility. It is important that the unit be installed in a stable condition with the front casters locked before operating.

### Plumbing

Self-contained models are standard with a condensate evaporator. If, for some reason, a unit does not have a condensate evaporator, or the evaporator fails, the unit's drain must have an outlet to an appropriate drainage area or container.



**Moisture collecting from improper drainage can create a slippery surface on the floor and a hazard to employees. It is the owner's responsibility to provide a container or outlet for drainage.**

### Electrical connection

Refer to the amperage data, the serial tag, your local code or the National Electrical Code to be sure the unit is connected to the proper power source. A protected circuit of the correct voltage and amperage must be run for connection of the line cord, or permanent connection to the unit.



**The power switch must be turned to OFF and the unit disconnected from the power source whenever performing service or maintenance functions. Never operate the unit without the louvered panel in place!**

## Operation: 18600PTBM & PTL Series



**Product should be loaded into the unit with care. Failure to heed these recommendations could result in damage to the interior of the cabinet or the blower coil.**

This unit is equipped with two ON/OFF switches located behind the louvered machine compartment panel. The unit's compressor and all evaporator fans will begin operating when the main power switch is turned to the **ON** position. Temperature ranges for the base are 36°F to 40°F.

The switch labeled rail is for the raised rail. The rail switch is accessible through a 1.5" diameter hole in the louvered panel. Turning this switch to the **ON** position will activate the refrigeration for the rail. Temperature ranges for the raised rail are 33°F to 41°F.



**Product located in the rail must be removed at the end of day. This allows you to turn the rail off at night to save energy and the rail will have time to defrost as needed.**

A minimum of one hour of off time per day with the pans removed from the rail is required to properly defrost the rail.



**The power must be turned to OFF and the unit disconnected from the power source whenever performing service or maintenance functions. Never operate the unit without the louvered panel in place!**

All R404A models have a high pressure limiting device. Under severe overloading conditions, or in the event of a condenser fan failure or a plugged or blocked condenser, this device may shut down the refrigeration system. This device will automatically reset, but determining the cause of the high pressure condition should be investigated by a qualified refrigeration technician.

### Refrigerator Evaporator Fan Operation

When the refrigerator is initially powered up or immediately following a power outage the unit will begin cooling after a 3-6 minute delay. During normal operation the evaporator fan pulses independently of the compressor as dictated by the controller as follows:

1. During the cooling mode, compressor and evaporator fan run simultaneously.
2. During the compressor off mode, evaporator fan pulses three minutes on and three minutes off.
3. During an actual defrost event other than the off-cycle defrost, compressor stays off but the evaporator fan runs continuously.

Cooling Cycle				Defrost Cycle	
Compressor On		Compressor Off		Compressor Off	
Evap Fan On	Evap Fan Off	Evap Fan On	Evap Fan Off	Evap Fan On	Evap Fan Off
X		Cycles On 3-Min, Off 3-Min		X	

## Operation: 18600BUCM & BSTM Series

After turning the **ON/OFF** switch to **ON**, the units compressor will begin operating. Delfield refrigerated bases are designed to maintain an operational temperature of 36°F to 40°F.



**Product should be loaded into the unit with care. Failure to heed these recommendations could result in damage to the interior of the cabinet or the blower coil.**

**Overloading the storage area, restricting the air flow and continuous opening and closing of the doors and drawers will hamper the units ability to maintain operational temperature.**

### Refrigerator Evaporator Fan Operation

When the refrigerator is initially powered up or immediately following a power outage the unit will begin cooling after a 3-6 minute delay. During normal operation the evaporator fan pulses independently of the compressor as dictated by the controller as follows:

1. During the cooling mode, compressor and evaporator fan run simultaneously.
2. During the compressor off mode, evaporator fan pulses three minutes on and three minutes off.
3. During an actual defrost event other than the off-cycle defrost, compressor stays off but the evaporator fan runs continuously.

Cooling Cycle				Defrost Cycle	
Compressor On		Compressor Off		Compressor Off	
Evap Fan On	Evap Fan Off	Evap Fan On	Evap Fan Off	Evap Fan On	Evap Fan Off
X		Cycles On 3-Min, Off 3-Min		X	

## Operation: 18600PDL Series



**Product should be loaded into the unit with care. Failure to heed these recommendations could result in damage to the interior of the cabinet or the blower coil.**

This unit is equipped with two ON/OFF switches located behind the louvered machine compartment panel. The unit's compressor and all evaporator fans will begin operating when the main power switch is turned to the **ON** position. Temperature ranges for the base are 36°F to 40°F (2°C to 4°C).

The switch labeled rail is for the raised rails. The rail switch is accessible through a 1.5" (3.8cm) diameter hole in the louvered panel. Turning this switch to the **ON** position will activate the refrigeration for the rails. Temperature ranges for the raised rails are 33°F to 41°F (0.5°C to 5°C).



**Product located in the rails must be removed at the end of day. This allows you to turn the rails off at night to save energy and the rails will have time to defrost as needed.** A minimum of one hour of off time per day with the pans removed from the rails is required to properly defrost the rails.



**The power must be turned to OFF and the unit disconnected from the power source whenever performing service or maintenance functions. Never operate the unit without the louvered panel in place!**

All R404A models have a high pressure limiting device. Under severe overloading conditions, or in the event of a condenser fan failure or a plugged or blocked condenser, this device may shut down the refrigeration system. This device will automatically reset, but determining the cause of the high pressure condition should be investigated by a qualified refrigeration technician.

### Refrigerator Evaporator Fan Operation

When the refrigerator is initially powered up or immediately following a power outage the unit will begin cooling after a 3-6 minute delay. During normal operation the evaporator fan pulses independently of the compressor as dictated by the controller as follows:

1. During the cooling mode, compressor and evaporator fan run simultaneously.
2. During the compressor off mode, evaporator fan pulses three minutes on and three minutes off.
3. During an actual defrost event other than the off-cycle defrost, compressor stays off but the evaporator fan runs continuously.

Cooling Cycle				Defrost Cycle	
Compressor On		Compressor Off		Compressor Off	
Evap Fan On	Evap Fan Off	Evap Fan On	Evap Fan Off	Evap Fan On	Evap Fan Off
X		Cycles On 3-Min, Off 3-Min		X	

## Operation: CTP-NB Series

The unit is equipped with one ON/OFF switch located on the right end of the unit. The unit's compressor will begin operating when this switch is turned to the **ON** position. Temperature ranges for the rail are 33°F to 41°F.



**Product located in the rail must be removed at the end of day. This allows you to turn the rail OFF at night to save energy and the rail will have time to defrost as needed.**

A minimum of one hour of off time per day with the pans removed from the rail is required to properly defrost the rail.



**The power switch must be turned to OFF and the unit disconnected from the power source whenever performing service or maintenance functions. Never operate the unit without the louvered panel in place!**



## Pressure Control Settings

The factory recommended low-pressure control settings for 18600PTBM's are: 55psi cut-in and 30psi cut-out to maintain proper temperature for product in the rail. The interior temperature is controlled by the thermostat mounted in the mechanical compartment.

The factory recommended low-pressure control settings for 18600PTL's are: 20psi (1.38bar) cut-in and 10psi (0.70bar) cut-out. The base and rail temperatures are controlled by the thermostats mounted in the machine compartment.

A pressure control is located in the machine compartment. An adjustable control has the word COLDER on the knob, with an arrow to indicate the adjustment direction. These controls are field adjustable and do not require a service agent.



In attempting to adjust the pressure control, you can do damage to your unit by accidentally adjusting the differential. Please make small incremental adjustments if a temperature adjustment is necessary. It may take an hour or longer to realize the temperature change depending on the application and location of the unit.

Please contact the service department at Delfield (800) 733-8829 or your local service agent. Delfield is not responsible for charges incurred while having the pressure control adjusted.

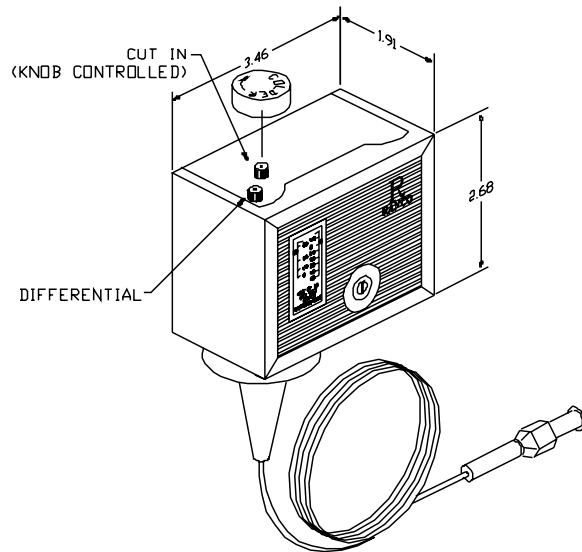

## Temperature Control Settings

A thermostat controls temperature in the 18600PTBM base, 18600PTL base, 18600PTL rail, BUCM, BSTM, 18600PDL base and 18600PDL rail.

Thermostats are located in the machine compartment. They are field adjustable and do not require a service agent. The factory setting is 2.5. Set toward 1 for higher temperatures and toward 7 for lower temperatures.



Please make small incremental adjustments if a temperature adjustment is necessary. It may take an hour or longer to realize the temperature change depending on the application and location of the unit.

Contact the service department at Delfield +1 (989) 773-7981 or your local service agent for additional assistance. Delfield is not responsible for charges incurred while adjusting the thermostat.

## Care & Cleaning

### Door Gasket Maintenance

Door gaskets require regular cleaning to prevent mold and mildew build up and also to retain the elasticity of the gasket. Gasket cleaning can be done with the use of warm soapy water. Avoid full strength cleaning products on gaskets as this can cause them to become brittle and crack. Never use sharp tools or knives to scrape or clean the gasket. Gaskets can be easily replaced and do not require the use of tools or an authorized service person. The gaskets are "Dart" style and can be pulled out of the groove in the door and new gaskets can be "pressed" back into place.

### Drain Maintenance - Base

Each unit has a drain located inside the unit that removes the condensation from the evaporator coil and routes it to an external condensate evaporator pan. Each drain can become loose or disconnected during normal use. If you notice water accumulation on the inside of the unit be sure the drain tube is connected to the evaporator drain pan. If water is collecting underneath the unit make sure the end of the drain tube is in the condensate evaporator in the machine compartment. The leveling of the unit is important as the units are designed to drain properly when level. Be sure all drain lines are free of obstructions.

### Drawer Maintenance

#### Drawer Assembly Cleaning

The drawer assembly is designed to be cleaned easily. Both drawer and tracks are removable without tools. The drawer tracks are dishwasher safe or can be cleaned in a sink with detergents and a soft bristle brush. Drawers and tracks should be cleaned on a weekly basis.

#### Remove Drawers

Pull the drawer box out until it stops. Lift up on the drawer front and pull the drawer box completely out. Using a soft bristle brush, clean the track on the bottom of the drawer box. When finished, it should be wiped clean of all food and debris.

#### Tracks

The drawer box assembly must be removed. Pull the drawer tracks out until they hit a stop. Locate blue safety clips towards the back of each drawer track. Blue safety clips have a tab on the top. Push the tab back until it clicks. Lift up and pull the drawer tracks all the way out of the drawer cage. The drawer tracks are dishwasher safe or can be cleaned in a sink with detergents and a soft bristle brush. Drawers and

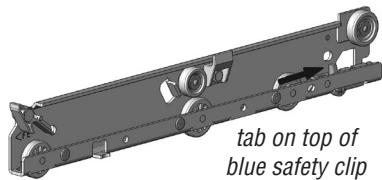

tracks should be cleaned on a weekly basis. Using a soft bristle brush, wash the track making sure each roller is thoroughly cleaned. The drawer cage should be cleaned with a soft bristle brush, removing any food and debris gathered on the bottom ledge. Once it's cleaned thoroughly with a soft bristle brush, wipe remaining debris clean with a soft towel.

#### Reassembly

Push the drawer tracks into the drawer cage. The blue safety clip must remain pushed towards the back. Lift up and slide the drawer track all the way into the drawer cage. The blue safety clip will lock

in place automatically. Once all tracks are replaced, insert the drawer box. Rest the drawer box bottom track on the front track roller. Then push the drawer back in place SLOWLY. When the drawer box is about half way in you will hit a STOP. You must lift the front of the drawer up approximately ½" (1.3cm) to continue inward. Clean tracks as often as possible. The cleaner the tracks are the better they will operate.

### Caster Maintenance

Wipe casters with a damp cloth monthly to prevent corrosion.



**The power switch must be turned to OFF and the unit disconnected from the power source whenever performing service, maintenance functions or cleaning the refrigerated area.**

### Refrigerators and Freezers

The interior and exterior can be cleaned using soap and warm water. If this isn't sufficient, try ammonia and water or a nonabrasive liquid cleaner. When cleaning the exterior, always rub with the "grain" of the stainless steel to avoid marring the finish. Do not use an abrasive cleaner because it will scratch the stainless steel and can damage the breaker strips and gaskets.

### Stainless Steel Care and Cleaning

To prevent discoloration of rust on stainless steel several important steps need to be taken. First, we need to understand the properties of stainless steel. Stainless steel contains 70- 80% iron, which will rust. It also contains 12-30% chromium, which forms an invisible passive film over the steels surface, which acts as a shield against corrosion. As long as the protective layer is intact, the metal is still stainless. If the film is broken or contaminated, outside elements can begin to breakdown the steel and begin to form discoloration of rust. Proper cleaning of stainless steel requires soft cloths or plastic scouring pads.

#### NEVER USE STEEL PADS, WIRE BRUSHES OR SCRAPERS!

Cleaning solutions need to be alkaline based or non-chloride cleaners. Any cleaner containing chlorides will damage the protective film of the stainless steel. Chlorides are also commonly found in hard water, salts, and household and industrial cleaners. If cleaners containing chlorides are used be sure to rinse repeatedly and dry thoroughly. Routine cleaning of stainless steel can be done with soap and water. Extreme stains or grease should be cleaned with a non-abrasive cleaner and plastic scrub pad. Always rub with the grain of the steel. There are stainless steel cleaners available which can restore and preserve the finish of the steels protective layer. Early signs of stainless steel breakdown are small pits and cracks. If this has begun, clean thoroughly and start to apply stainless steel cleaners in attempt to restore the passivity of the steel.



**Never use an acid based cleaning solution! Many food products have an acidic content, which can deteriorate the finish. Be sure to clean the stainless steel surfaces of ALL food products. Common items include, tomatoes, peppers and other vegetables.**

### Cleaning the Condenser Coil

In order to maintain proper refrigeration performance, the condenser fins must be cleaned of dust, dirt and grease regularly. It is recommended that this be done at least every three months.

## Care & Cleaning, continued

If conditions are such that the condenser is totally blocked in three months, the frequency of cleaning should be increased. Clean the condenser with a vacuum cleaner or stiff brush. If extremely dirty, a commercially available condenser cleaner may be required.

Failure to maintain a clean condenser coil can initially cause high temperatures and excessive run times. Continuous operation with a dirty or clogged condenser coil can result in compressor failure. Neglecting the condenser coil cleaning procedures will void any warranties associated with the compressor and cost to replace the compressor.



**Never use a high-pressure water wash for this cleaning procedure as water can damage the electrical components located near or at the condenser coil.**

### Doors/Hinges

Over time and with heavy use doors the hinges may become loose. If this happens tighten the screws that mount the hinge brackets to the frame of the unit. Loose or sagging doors can cause the hinges to pull out of the frame, which may damage both the doors and the hinges. In some cases this may require qualified service agents or maintenance personnel to perform repairs.



**Do not place hot pans on/against the blue ABS liner. Do not throw items into the storage area. Failure to follow these recommendations could result in damage to the interior of the cabinet or to the blower coil. Overloading the storage area, restricting the airflow, and continuous opening and closing of the doors and drawers will hamper the units ability to maintain operational temperature.**

### Refrigerated rail units

Product in the rail should be removed to the refrigerated base at the end of the day. This allows you to turn the rail off at night to save energy and to defrost the rail. It also helps maintain product quality. The standard wrapped refrigerated rail units are controlled by a low-pressure control that is set to maintain the proper rail temperature. An on/off switch is also provided for the rail and is required to be shut off at night. With a LiquiTec rail a thermostat is provided to maintain rail temperature as well as the rail on/off switch. The LiquiTec rail is required to be shut off at night as well to allow for defrosting. To ensure product quality in the rail it is recommended that product be rotated every four hours.



**If adding any item to the unit, be sure to keep in mind the location of the refrigeration lines on wrapped rail units. A refrigeration leak in a rail is extremely difficult and costly to repair. In some cases it cannot be repaired at all.**

### Preventing blower coil corrosion

To help prevent corrosion of the blower coil, store all acidic items, such as pickles and tomatoes, in sealable containers. Immediately wipe up all spills.



**Units with pans should be operated with pans in place. Operating the unit without all pans in place will lower efficiency and may damage the unit.**

Continuous opening and closing of the doors will hamper the unit's ability to maintain optimum refrigeration temperature. Top section is not intended for overnight storage. Product should be removed from pans. Pans can remain in unit while empty.

## Wiring Diagram - 18600PTBM Series

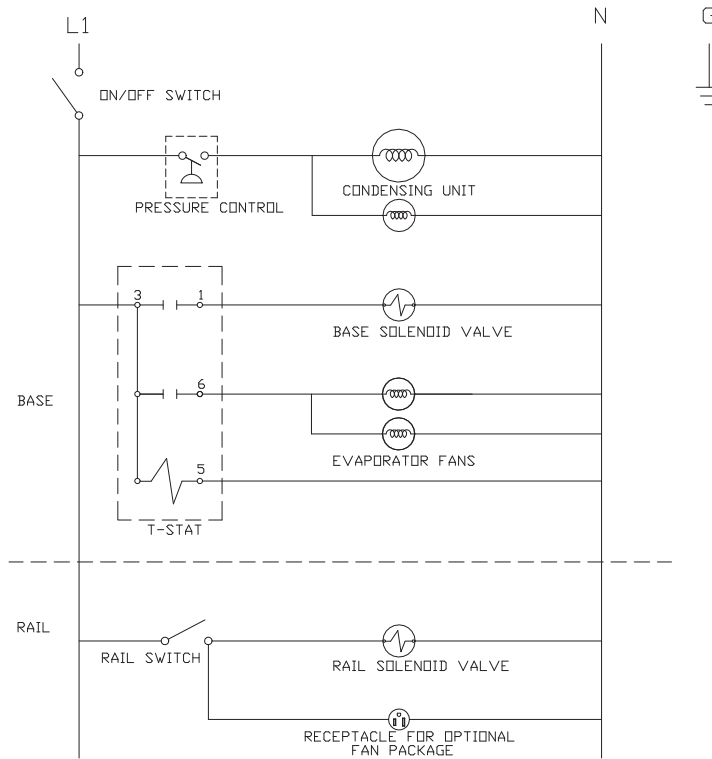

## Wiring Diagram - 18600PTL Series

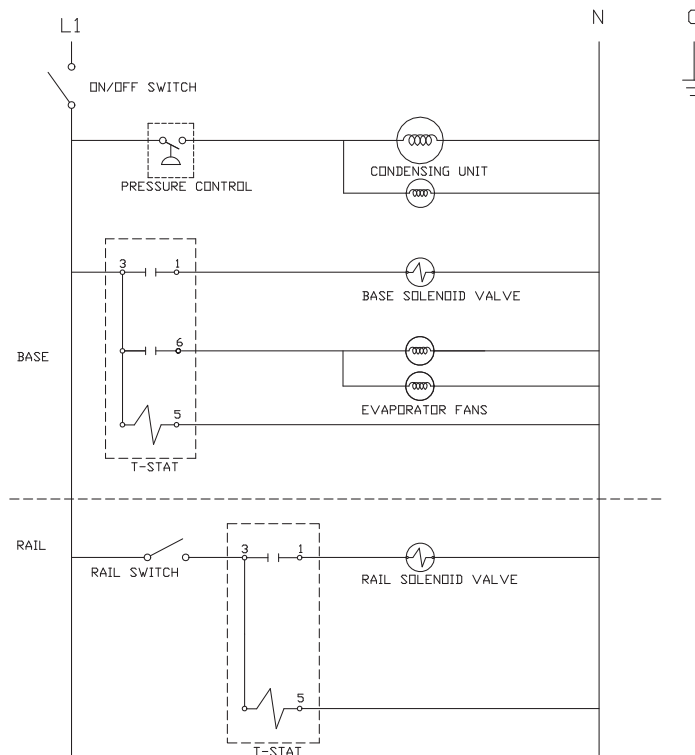

### Wiring Diagram - 18600BUCM & BSTM Series

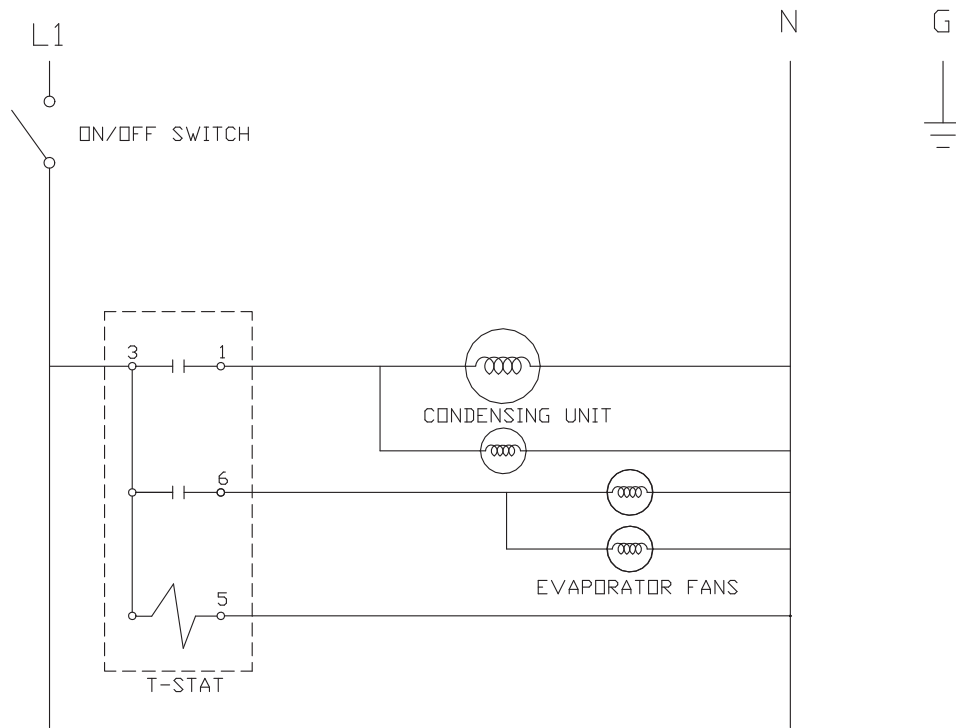

### Wiring Diagram - 18600PDL Series

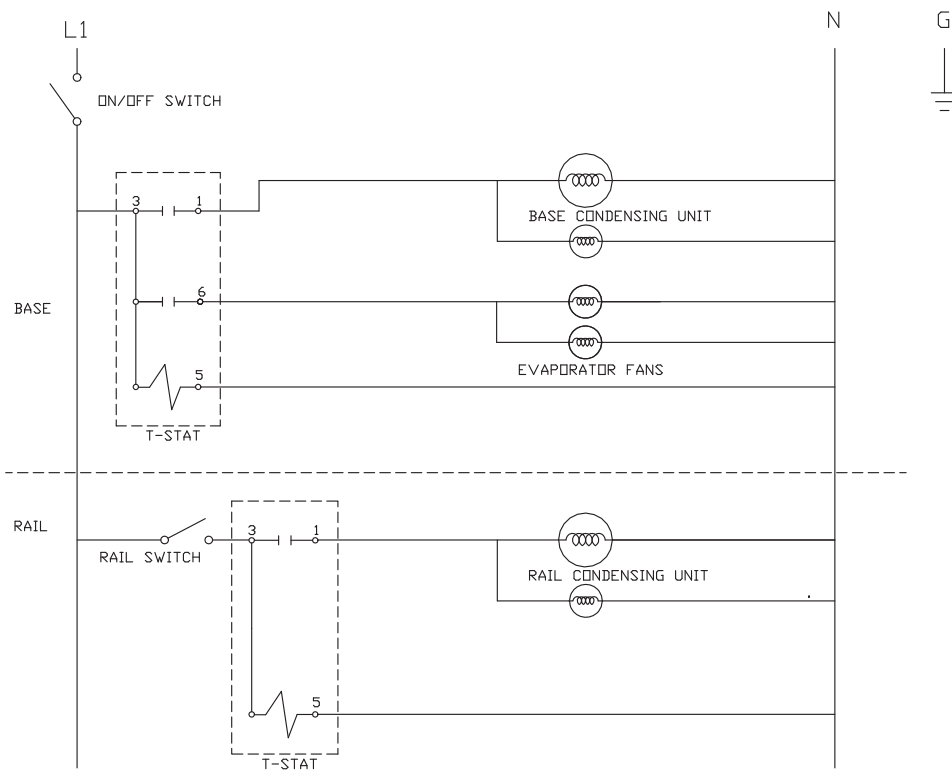

## Wiring Diagram - CTP-NB Series

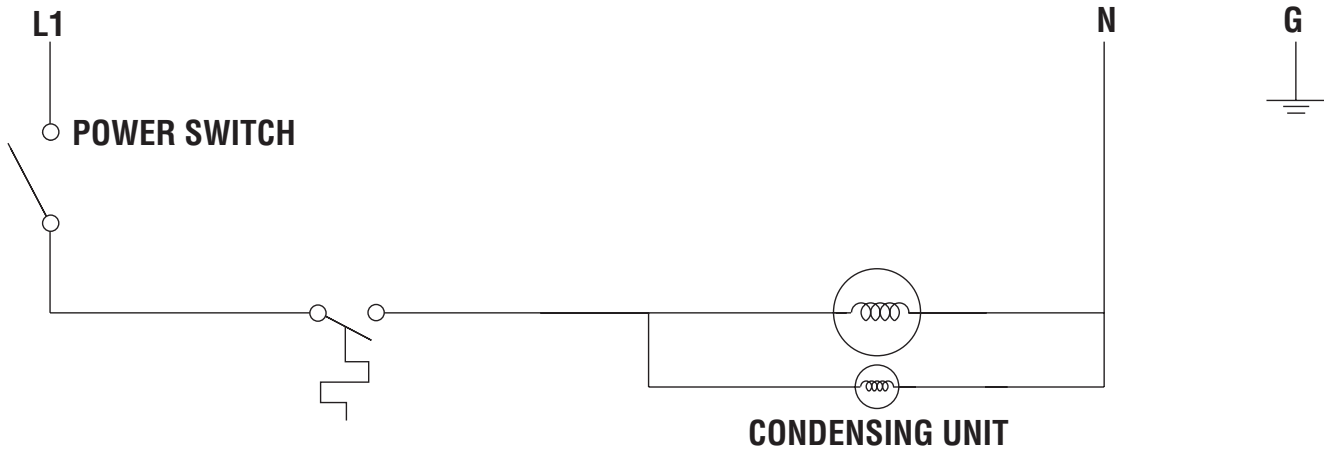

**TEMPERATURE CONTROLS THE CONDENSING UNIT**

# 18600PTBM Replacement Parts

## All 18600PTBM Models

3234290	1" Shelf Support
9321132	1.5" Shelf Support Screw
3234198	Caster, 5, Plate ,Swivel
3234199	Caster, 5, Plate, Swivel, Break
3234392	Hinge, Pan Cover, Center
3234282	Hinge, Pan Cover, End, LH
3234266	Hinge, Pan Cover, End, RH
2190154	Switch, Rocker, 20A/125V,

		186114PTBM	18699PTBM	18691PTBM	18672PTBM	18660PTBM	18648PTBM
*000-BN5-0030	Assembly, 1/4 HP Condensing Unit						X
*000-BN5-0037	Assembly, 1/3 Condensing Unit					X	
*000-BN5-0035	Assembly, 1/2 HP Condenser, Med		X	X	X		
*000-BN5-0036	Assembly, 3/4 HP Condenser, Med	X					
*000-187-007Y	Assembly, Dr, Ref, 19X26, LT, 430					X	
*000-187-007X	Assembly, Dr, Ref, 19X26, RT, 430			X			
*000-187-0082	Assembly, Dr, Ref, 27X26, LT, 430		X		X		X
*000-187-0081	Assembly, Dr, Ref, 27X26, RT,430		X	X	X	X	
*000-187-0084	Assembly, Dr, Ref, 32X26, LT, 430	X					
*000-187-0083	Assembly, Dr, Ref, 32X26, RT, 430	X					
*000-402-004Q	Assembly, Hinged Cover, 6 Pan, RT					X	
*000-402-004V	Assembly, Hinged Cover, 8 Pan	X					
*000-402-004U	Assembly, Hinged Cover, 8 Pan, RT				X		
*000-402-004X	Assembly, Hinged Cover, 10 Pan, LT	X			X		
*000-402-004Y	Assembly, Hinged Cover, 10 Pan, RT	X		X			
*000-402-0050	Assembly, Hinged Cover, 12 Pan						X
*000-402-0051	Assembly, Hinged Cover, 12 Pan, LT		X	X			
*000-402-0052	Assembly, Hinged Cover, 12 Pan, RT		X				
*000-282-006I	Assembly, Control, Tstat & Pressure Control	X					
*000-282-006D	Assembly, Tstat & Low Pressure Control		X	X	X		
*000-282-006C	Assembly, Tstat & Low Pressure Control					X	X
*000-248-0030	Coil Assembly, R404A	X	X	X	X	X	
*000-248-0037	Coil Assembly, R404A, Fan Lt						X
*359-478-003C	Panel, Louver, 14.0, PTB					X	
*359-478-003E	Panel, Louver, 15.0, PTB						X
*359-478-003D	Panel, Louver, 18.0, PTB	X	X	X	X		
3977984	Shelf, Wire, 19X32DP			X		X	
3977983	Shelf, Wire, 32X32 DP	X					
3978014	Shelf, Wire, Coated		X	X	X	X	X

\*Exploded assemblies and part prints are on the following pages.

## 18600BUCM Replacement Parts

### All 18600BUCM Models

3234290	1" Shelf Support
9321132	1.5" Shelf Support Screw
3234198	Caster, 5, Plate, Swivel
3234199	Caster, 5, Plate, Swivel, Brake
*000-298-003P	Control Assembly

		186114BUCM	18699BUCM	18691BUCM	18672BUCM	18660BUCM	18648BUCM
*000-BN5-0031	Assembly, 1/5 Condensing Unit					X	X
*000-BN5-0030	Assembly, 1/4 HP Condensing Unit		X	X	X		
*000-BN5-0037	Assembly, 1/3 Condensing Unit	X					
*000-187-007Y	Assembly, Dr, Ref, 19X26, LT, 430					X	
*000-187-007X	Assembly, Dr, Ref, 19X26, RT, 430			X			
*000-187-0082	Assembly, Dr, Ref, 27X26, LT, 430		X	X	X		X
*000-187-0081	Assembly, Dr, Ref, 27X26, RT, 430		X	X	X	X	
*000-187-0084	Assembly, Dr, Ref, 32X26, LT, 430	X					
*000-187-0083	Assembly, Dr, Ref, 32X26, RT, 430	X					
*000-248-0030	Coil Assembly, R404A	X	X	X	X	X	
*000-248-0037	Coil Assembly, R404A, Fan Lt						X
*359-478-0040	Panel, Louver, 14, Hanging					X	
*359-478-0042	Panel, Louver, 15, Hanging						X
*359-478-0041	Panel, Louver, 18, Hanging	X	X	X	X		
3977984	Shelf, Wire, 19X32DP			X		X	
3977983	Shelf, Wire, 32X32DP	X					
3978014	Shelf, Wire, Coated		X	X	X	X	X

\*Exploded assemblies and part prints are on the following pages.



## 18600BSTM & 18600PTL Replacement Parts

### All 18600BSTM Models

3234290	1" Shelf Support
9321132	1.5" Shelf Support Screw
3234198	Caster, 5, Plate, Swivel
3234199	Caster, 5, Plate, Swivel, Brake
*000-298-003P	Control Assembly

		186114BSTM	18699BSTM	18691BSTM	18672BSTM	18660BSTM	18648BSTM
*000-BN5-0031	Assembly, 1/5 Condensing Unit					X	X
*000-BN5-0030	Assembly, 1/4 HP Condensing Unit		X	X	X		
*000-BN5-0037	Assembly, 1/3 Condensing Unit	X					
*000-187-007Y	Assembly, Dr, Ref, 19X26, LT, 430					X	
*000-187-007X	Assembly, Dr, Ref, 19X26, RT, 430			X			
*000-187-0082	Assembly, Dr, Ref, 27X26, LT, 430		X	X	X		X
*000-187-0081	Assembly, Dr, Ref, 27X26, RT, 430		X	X	X	X	
*000-187-0084	Assembly, Dr, Ref, 32X26, LT, 430	X					
*000-187-0083	Assembly, Dr, Ref, 32X26, RT, 430	X					
*000-248-0030	Coil Assembly, R404A	X	X	X	X	X	
*000-248-0037	Coil Assembly, R404A, Fan Lt						X
*359-478-0040	Panel, Louver, 14, Hanging					X	
*359-478-0042	Panel, Louver, 15, Hanging						X
*359-478-0041	Panel, Louver, 18, Hanging	X	X	X	X		
3977984	Shelf, Wire, 19X32DP			X		X	
3977983	Shelf, Wire, 32X32DP	X					
3978014	Shelf, Wire, Coated		X	X	X	X	X

### All 18600PTL Models

3234290	1" Shelf Support	3516053	Coil, Solenoid, 120V
9321132	1.5" Shelf Support Screw	3234392	Hinge, Pan Cover, Center
*000-187-0082	Assembly, Dr, Ref, 27X26, LT, 430	3234282	Hinge, Pan Cover, End, LH
*000-402-0055	Assembly, Hinged Cover, 12 Pan, PTL	3234266	Hinge, Pan Cover, End, RH
263-ASB-0030	Bracket, Cutting Board, Center	3978014	Shelf, Wire, Coated
263-110-0034	Bracket, Cutting Board, LH	2190154	Switch, Rocker, 20A/125V
263-110-0036	Bracket, Cutting Board, RF	3516225	Valve, Expansion, Frz, 1/4Ton
3234198	Caster, 5, Plate, Swivel	3516102	Valve, Solenoid, 1/4ODF
3234199	Caster, 5, Plate, Swivel, Brake		

		18699PTL	18672PTL	18648PTL
*000-BN5-0030	Assembly, 1/4 HP Condensing Unit			X
*000-BN5-0035	Assembly, 1/2HP Condenser, MED	X	X	
*000-282-006L	Assembly, Control, 15A			X
*000-282-006M	Assembly, Control, 20A	X	X	
*000-187-0081	Assembly, Dr, Ref, 27X26, RT, 430	X	X	
*000-402-0054	Assembly, Hinged Cover, 6 Pan, PTL		X	
*000-248-0030	Coil Assembly, R404A	X	X	
*000-248-0037	Coil Assembly, R404A, Fan Lt			X



## CTP8000-NB & 18600PDL Replacement Parts

### All CTP8000-NB Models

243-ALS-0032	Divider, Bar, Cold
3234392	Hinge, Pan Cover, Center
3234282	Hinge, Pan Cover, End, LH
3234266	Hinge, Pan Cover, End, RH
9321374	Pin, Hinge, Salad Pan

		CTP8175-NB	CTP8160-NB	CTP8146-NB
*000-254-Z000B	Condenser Assembly, 1/5HP, CTP-8100	X		
*000-AUX-0038	Condensing Unit Assembly, 1/5HP, CTP		X	X
*223-016-Z000P	Cover, Hinged, CTP	X		
*312-016-003U	Cover, Pan, Rail, 8 Pan			X
*312-016-003W	Cover, Pan, Rail, 12 Pan		X	
243-ALS-0030	Divider, Bar, Cold	X		
243-ALS-0036	Divider, Bar, Cold		X	X
*356-411-Z0009	Louver, Front, CTP-8100	X		
*026-411-Z000A	Louver, Rear, CTP-8100	X		
*356-411-0004	Panel, Louver, Front CTP-8100		X	X

### All 18600PDL Models

*000-187-0082	Assembly, Door, Ref, 27X26, LT, 430	3234266	Hinge, Pan Cover, End, RH
*000-402-0054	Assembly, Hinged Cover, 6 Pan, PTL	9321374	Pin, Hinge, Salad Pan
263-110-0034	Bracket, Cutting Board	3978014	Shelf, Wire, Coated
263-110-0036	Bracket, Cutting Board	3234290	Support, Shelf, Plastic
3234186	Caster, 3DIA, Swivel, Plate	2190154	Switch, Rocker, 20A/125V
3234392	Hinge, Pan Cover	3516135	Thermometer, Hanging, 4
3234282	Hinge, Pan Cover, End, LH		

Part Number	Description	18672PDL	18648PDL
*000-BN5-003Y	Assembly, 1/2-1/5 Cond Unit Stacked	X	
*000-BN5-0040	Assembly, 1/3-1/5 Cond Unit Stacked		X
*000-282-006V	Assembly, Control, L/T, 48"		X
*000-282-006K	Assembly, Control, L/T, 72"	X	
*000-187-0081	Assembly, Door, Ref, 27X26, RT, 430	X	
*000-248-0030	Coil Assembly, R404A	X	
*000-248-0037	Coil Assembly, R404A, Fan Lt		X
*359-478-003E	Panel, Louver, 15.0, PTB		X
*359-478-003D	Panel, Louver, 18.0, PTB	X	

\*Exploded assemblies and part prints are on the following pages.

## Replacement Parts - Control Assemblies

Key	Part Number	Description
-	<b>000-282-006I</b>	<b>Thermostat &amp; Dual Pressure Control Assembly</b>
1	2193942	Dual pressure control
2	2190154	Rocker switch, 20A/125V
3	2194824	Control, Danfoss, GDM, 115V

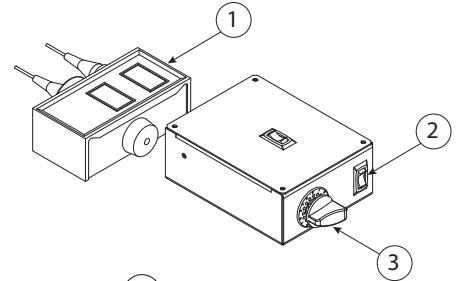

Key	Part Number	Description
-	<b>000-282-006C &amp; 000-282-006D</b>	<b>Thermostat &amp; Low Pressure Control Assembly</b>
1	2193927	Low pressure control
2	2190154	Rocker switch, 20A/125V
3	2194824	Control, Danfoss, GDM, 115V

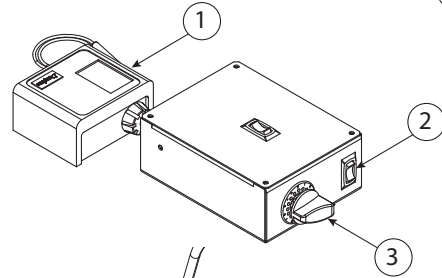

Key	Part Number	Description
-	<b>000-298-003P</b>	<b>Control Assembly</b>
1	2194810	Control, Danfoss, GDM, 115V
2	2190154	Rocker switch, 20A/125V

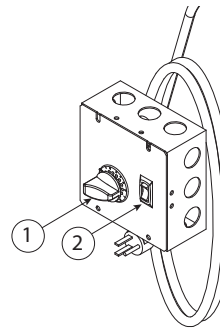

Key	Part Number	Description
-	<b>000-282-006L &amp; 000-282-006M</b>	<b>Control Assembly, LiquiTec, 2SW</b>
1	2193927	Low pressure control
2	000-282-0051	Tstat Assembly, Danfoss, MK7
3	2190154	Rocker switch, 20A/125V
4	2194824	Control, Danfoss, GDM, 115V

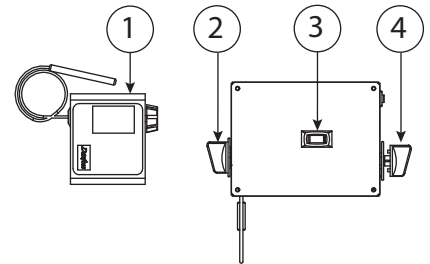

Key	Part Number	Description
-	<b>000-282-006K</b>	<b>72" LiquiTec Dual Rail Control Assembly</b>
1	000-282-0051	Tstat Assembly, Danfoss, MK7
2	2190154	Rocker switch, 20A/125V
3	2194824	Control, Danfoss, GDM, 115V

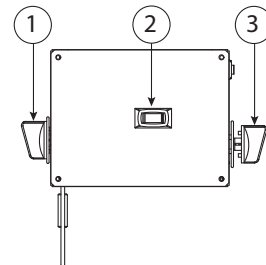

Key	Part Number	Description
-	<b>000-282-006V</b>	<b>48" LiquiTec Dual Rail Control Assembly</b>
1	000-282-0053	Tstat Assembly, Danfoss, MK7
2	2190154	Rocker switch, 20A/125V
3	2194824	Control, Danfoss, GDM, 115V

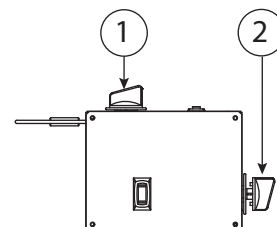

# Replacement Parts - Condensing Unit Assemblies

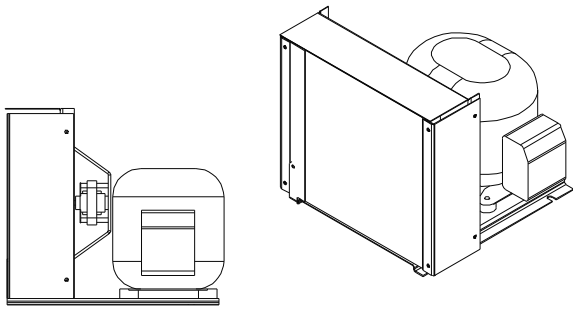

Part Number	Description
<b>000-AUX-0038</b>	<b>Condensing Unit Assembly, 1/5HP, CTP</b>
3526694	Compressor
3516082	Condenser Coil
3516172	Fan Blade
2162691	Fan Motor
031-264-0000	Fan Motor Bracket
3516191	Filter Drier
3516047	Temp Control

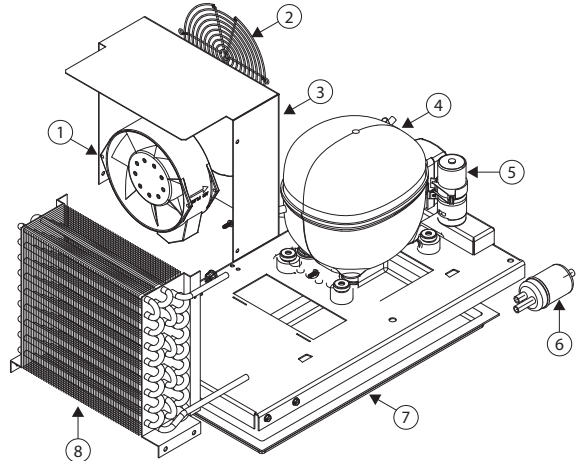

-	<b>000-BN5-0031</b>	<b>Assembly, 1/5 Condensing Unit</b>
1	2160028	Fan, Axial, 5.5", 120V
2	2160030	Guard, Fan, 6.0"
3	026-C58-0037	Shroud, Condenser Coil
4	3526997	Compressor, Danfoss, TF4CLS
5	2194787	Start Capacitor
6	3516322	Filter Drier
7	075-231-0030	Condensate Pan
8	3516454	Condenser Coil

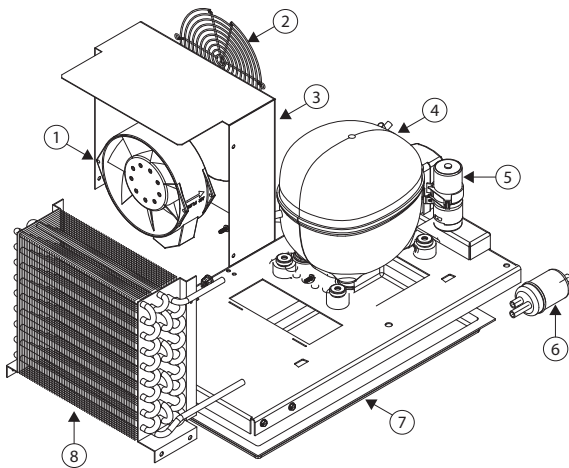

Key	Part Number	Description
-	<b>000-BN5-0030</b>	<b>Assembly, 1/4 HP Condensing Unit</b>
1	2160028	Fan, Axial, 5.5", 120V
2	2160030	Guard, Fan, 6.0"
3	026-C58-0037	Shroud, Condenser Coil
4	3526999	Compressor, Danfoss, NF5.5CLX
5	2194787	Start Capacitor
6	3516322	Filter Drier
7	075-231-0030	Condensate Pan
8	3516454	Condenser Coil

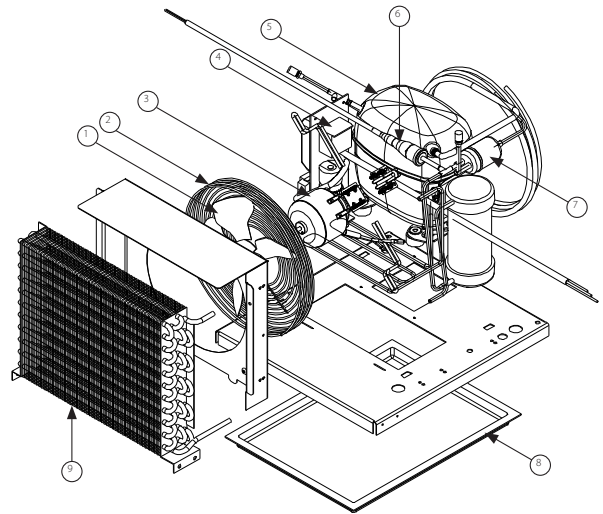

-	<b>000-BN5-0035</b>	<b>Assembly, 1/2HP Condenser, Med</b>
1	3516554	Condenser fan blade
2	2160019	Condenser fan guard
3	2162716	Condenser fan motor, 115V
4	3516462	Capacitor, start-run assy
5	3527026	Compressor, Danfoss, SC12MLX
6	3516331	Hi pressure switch
7	3516322	Filter Drier
8	075-231-0031	Pan, Condensate
9	3516455	Condenser coil

# Replacement Parts - Condensing Unit Assemblies

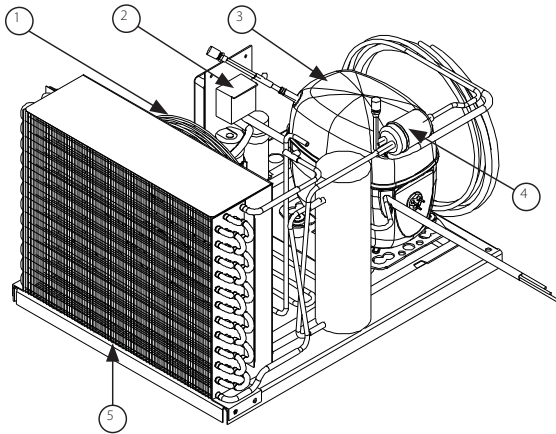

Key	Part Number	Description
-	<b>000-BN5-0036</b>	<b>Assembly, 3/4 HP Condenser, Med</b>
1	2160019	Guard, Fan, Wire
2	3516442	Capacitor, Start, Run, Assembly
3	3527021	Compressor, 3/4 HP Med
4	3516322	Drier, Filter, (2)Inlet
5	3516456	Coil, Condenser, 3/4 HP
-	3516433	Blade, Fan, 25Deg, 10", CW
-	2162716	Motor, Fan, 16W, 115V, CW
-	075-231-0031	Pan, Condensate, Sm

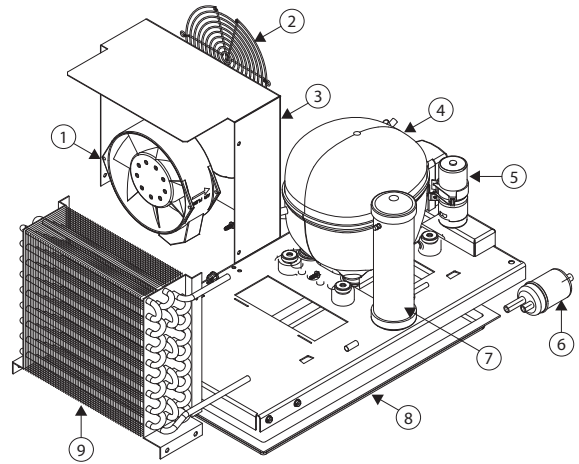

Key	Part Number	Description
-	<b>000-BN5-0037</b>	<b>Assembly, 1/3 Condensing Unit</b>
1	2160028	Fan, Axial, 5.5", 120V
2	2160030	Guard, Fan, 6.0"
3	026-C58-0037	Shroud, Condenser Coil
4	3527000	Compressor, Danfoss, NF7CLS
5	2194788	Start Capacitor
6	3516322	Filter Drier
7	3516458	Receiver tank
8	075-231-0030	Pan, Condensate
9	3516454	Condenser Coil

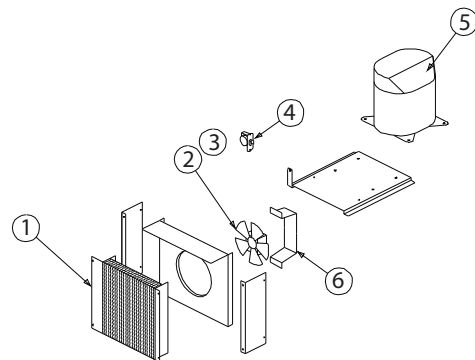

Key	Part Number	Description
-	<b>000-254-Z000B</b>	<b>Condenser Assembly, 1/5HP, CTP-8100</b>
1	3516082	Condenser Coil
2	3516172	Fan Blade
3	2162691	Fan Motor
4	3516047	Temp Control
5	3526694	Compressor
6	031-264-0000	Fan Motor Bracket
-	3516191	Filter Drier

## Replacement Parts - Condensing Unit Assemblies

<b>000-BN5-003Y</b>	<b>Assembly, 1/2-1/5 Stacked</b>
3516433	Blade, Fan, 25Deg, 10", CW
3516457	Blade, Fan, 7.25 DIA.
2194789	Capacitor, Start, 240MFD
2194787	Capacitor, Start, 280MFD
3516455	Coil, Cond., 1/2 HP
3516454	Coil, Cond., 1/5, 1/4
3526997	Comp, 1/5HP, 115/60, R404A
3527001	Comp, SC12CLX.2, 115/60HZ
3516446	Compressor, Relay, Danfoss
3516322	Drier, Filter, (2) Inlet
2160020	Guard, Fan, 7.25
2160019	Guard, Fan, Wire
2162513	Motor, Fan, 35W, Blast
2162717	Motor, Fan, 9W, 115V, CW
3516193	Regulator, Pressure, 1/2
3516441	Relay, Compressor, SC12CLX.2
3516225	Valve, Exp, Frz, 1/4 Ton

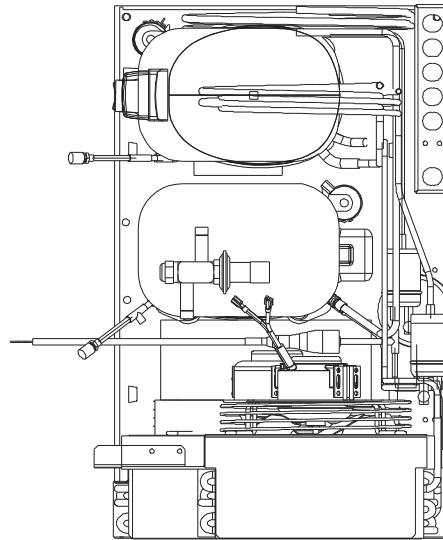

<b>000-BN5-0040</b>	<b>Assembly, 1/3-1/5 Stacked</b>
3516457	Blade, Fan, 7.25 DIA.
2194787	Capacitor, Start, 280MFD
2194788	Capacitor, Start, 320MFD
3516454	Coil, Cond., 1/5, 1/4
3526997	Comp, 1/5HP, 115/60, R404A
3527000	Comp, NF7CLS, 115V/60HZ
3516446	Comp, Relay, Danfoss
3516322	Drier, Filter, (2) Inlet
2160020	Guard, Fan, 7.25
2162717	Motor, Fan, 9W, 115V, CW
3516193	Regulator, Pressure, 1/2
3516438	Relay, Comp, Ovld, NF7CLX
3516225	Valve, Exp, Frz, 1/4 Ton

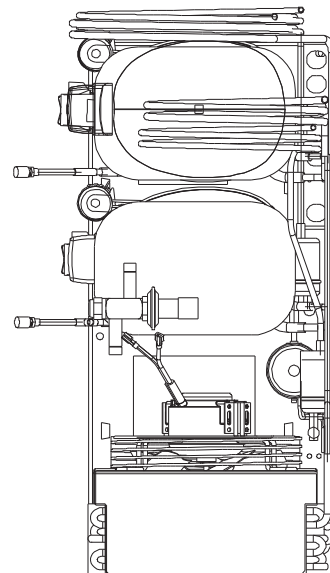

## Replacement Parts - Evaporator Coil Assembly

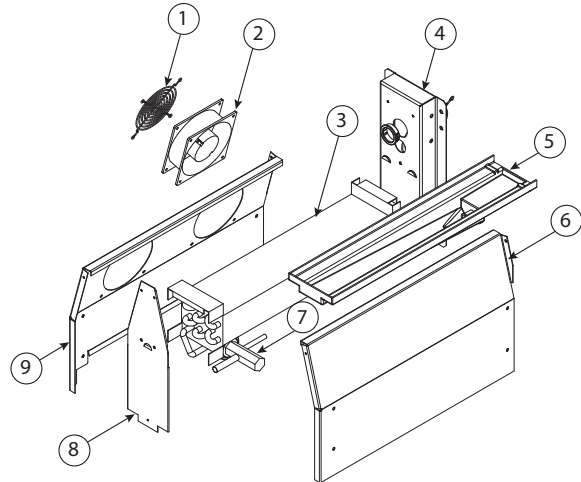
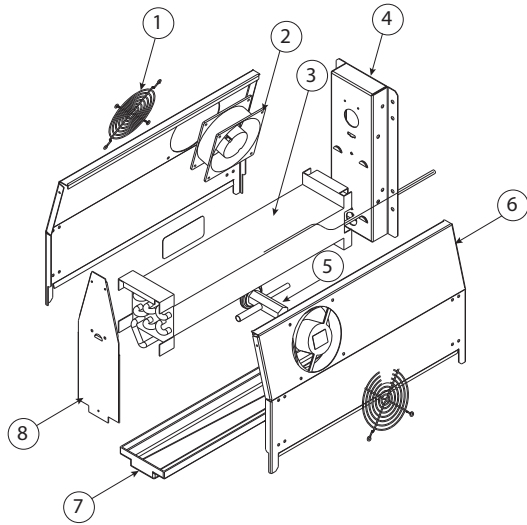

Key	Part Number	Description
-	<b>000-248-0030</b>	<b>Coil Assembly, R404A, Ref</b>
1	2160024	Guard, fan, 4.7"
2	2160023	Fan, axiel, 120V
3	3516095	Coil, evaporator
4	030-232-0003	Back, evaporator, enclosure
5	3516273	Expansion valve, 1/4, R-404a
6	030-233-0001	Side, coil, angled
7	075-231-0033	Drip pan, evaporator
8	030-234-0003	Front, coil
-	2184317	Harness, coil
-	2194808	Probe, Defrost, Danfoss, Control
-	2194809	Probe, Temp, Sensor, Danfoss

Key	Part Number	Description
-	<b>000-248-0037</b>	<b>Coil Assembly, R404A, Ref, Fan Lt</b>
1	2160024	Guard, fan, 4.7"
2	2160023	Fan, axiel, 120V
3	3516095	Coil, evaporator
4	030-232-0003	Back, evaporator, enclosure
5	000-BNH-0030	Drip pan, evaporator
6	030-233-0038	Side, coil, angled, Rt, Blank
7	3516273	Expansion valve, 1/4, R-404a
8	030-234-0003	Front, coil
9	030-233-0039	Side, Coil, Angled, Lt, 2Fan
-	2184317	Harness, coil
-	2194808	Probe, Defrost, Danfoss, Control
-	2194809	Probe, Temp, Sensor, Danfoss

## Replacement Parts - Louvered Panels

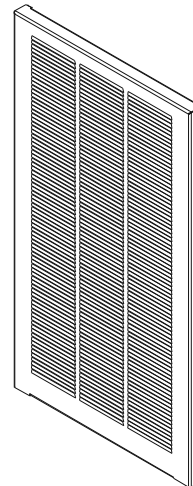
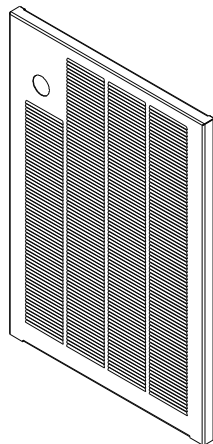
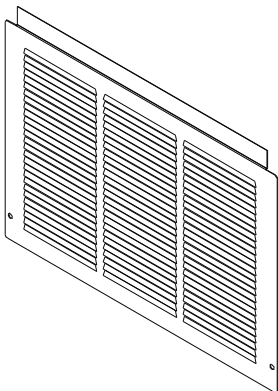

Part Number	Description
356-411-Z0009	Louver, Front, CTP-8100
026-411-Z000A	Louver, Rear, CTP-8100
356-411-0004	Panel, Louver, Front CTP-8100

Part Number	Description
359-478-003C	Panel, Louver, 14.0, PTB
359-478-003E	Panel, Louver, 15.0, PTB
359-478-003D	Panel, Louver, 18.0, PTB

Part Number	Description
359-478-0040	Panel, Louver, 14, Hanging
359-478-0042	Panel, Louver, 15, Hanging
359-478-0041	Panel, Louver, 18, Hanging



# Replacement Parts - Door & Cover Assemblies

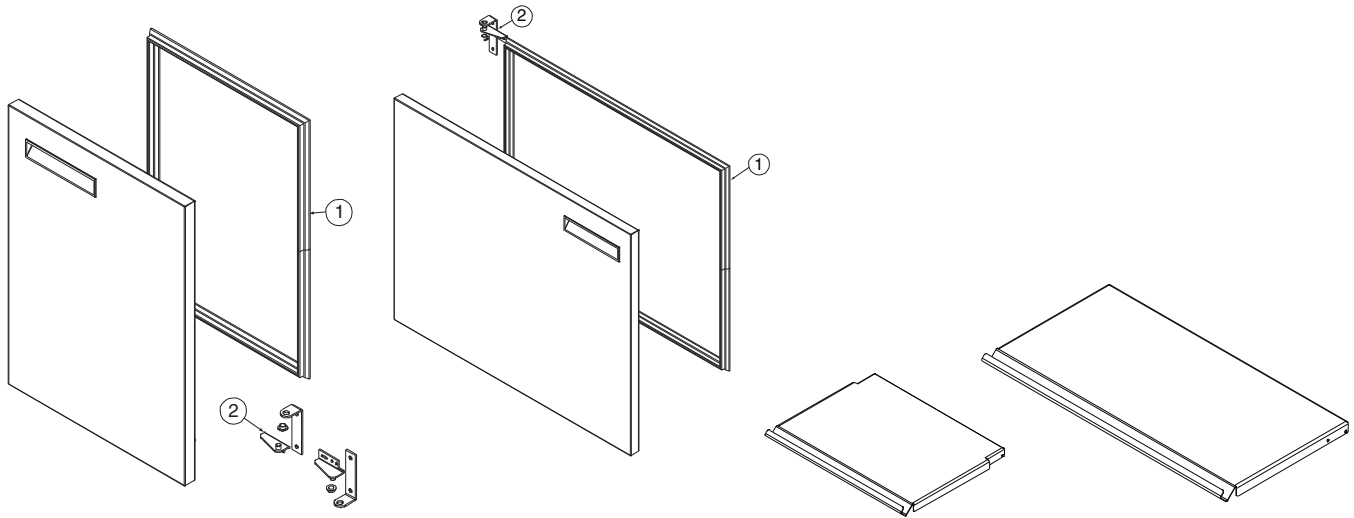

Key	Part Number	Description
-	<b>000-187-007X</b>	<b>Assembly, Dr, Ref, 19X26, RT, 430</b>
1	1701183	Gasket, Dr, 19, Mark7
2	0160179	Hinge Kit
-	<b>000-187-007Y</b>	<b>Assembly, Dr, Ref, 19X26, LT, 430</b>
1	1701183	Gasket, Dr, 19, Mark7
2	0160179	Hinge Kit
-	<b>000-187-0081</b>	<b>Assembly, Dr, Ref, 27X26, RT, 430</b>
1	1701185	Gasket, Dr, 27, Mark7
2	0160179	Hinge Kit
-	<b>000-187-0082</b>	<b>Assembly, Dr, Ref, 27X26, LT, 430</b>
1	1701185	Gasket, Dr, 27, Mark7
2	0160179	Hinge Kit
-	<b>000-187-0083</b>	<b>Assembly, Dr, Ref, 32X26, RT, 430</b>
1	1701186	32" Door Gasket
2	0160179	Hinge Kit
-	<b>000-187-0084</b>	<b>Assembly, Dr, Ref, 32X26, LT, 430</b>
1	1701186	32" Door Gasket
2	0160179	Hinge Kit

Part Number	Description
000-402-0054	Assembly, Hinged Cover, 6 Pan, PTL
000-402-004Q	Assembly, Hinged Cover, 6 Pan, RT
000-402-004V	Assembly, Hinged Cover, 8 Pan
000-402-004U	Assembly, Hinged Cover, 8 Pan, RT
000-402-004X	Assembly, Hinged Cover, 10 Pan, LT
000-402-004Y	Assembly, Hinged Cover, 10 Pan, RT
000-402-0050	Assembly, Hinged Cover, 12 Pan
000-402-0051	Assembly, Hinged Cover, 12 Pan, LT
000-402-0055	Assembly, Hinged Cover, 12 Pan, PTL
000-402-0052	Assembly, Hinged Cover, 12 Pan, RT
223-016-Z000P	Cover, Hinged, CTP
312-016-003U	Cover, Pan, Rail, 8 Pan
312-016-003W	Cover, Pan, Rail, 12 Pan



## Standard Labor Guidelines To Repair Or Replace Parts On Delfield Equipment

Advice and recommendations given by Delfield Service Technicians do not constitute or guarantee any special coverage.

- A maximum of 1-hour is allowed to **diagnose a defective component**.
- A maximum of 1-hour is allowed for **retrieval of parts** not in stock.
- A maximum **travel distance** of 100 miles round trip and 2-hours will be reimbursed.
- Overtime, installation/start-up, normal control adjustments, general maintenance, glass breakage, freight damage, and/or correcting and end-user installation error will not be reimbursed under warranty unless pre-approved with a **Service Work Authorization** from Delfield. You must submit the number with the service claim.

### LABOR OF 1-HOUR IS ALLOWED TO REPLACE:

- Thermostat
- Evaporator/Condenser Fan Motor and Blade
- Door Hinges, Locks, and Gaskets
- Compressor Start Components and Overload Protector
- Thermometer
- Solenoid Coil

### LABOR OF 2 HOURS TO REPLACE:

- Drawer Tracks/Cartridges
- Solenoid Valve
- Pressure Control
- Locate/Repair Leak

### LABOR OF 3 HOURS TO REPLACE:

- Condenser or Evaporator Coil
- Expansion Valve

### LABOR OF 4 HOURS TO REPLACE

- Compressor

This includes recovery of refrigerant and leak check.

\$55.00 maximum reimbursement for refrigerant recovery (includes recovery machine, pump, torch, oil, flux, minor fittings, solder, brazing rod, nitrogen or similar fees.)

### REFRIGERANTS

- R404A A maximum of \$15.00/lb. or \$1.00/oz. will be reimbursed.



## Notes

# Notes



***Mt. Pleasant, MI***



***Covington, TN***

*Thank you for choosing Delfield!*

Help is a phone call away. Help our team of professional, courteous customer service reps by having your model number and serial number available at the time of your call (800) 733-8829.

Model: \_\_\_\_\_ S/N: \_\_\_\_\_

Installation Date: \_\_\_\_\_



For a list of Delfield's authorized parts depots, visit our website at [www.delfield.com](http://www.delfield.com)

Register your Delfield warranty online. Go to [www.delfield.com](http://www.delfield.com) under the service tab to complete.

