



# International 200 & 300 Series

## Service and Installation Manual

Please read this manual completely before attempting to install or operate this equipment!  
Notify carrier of damage! Inspect all components immediately.



**Drop In and Undercounter Products**











**Important Information  
Read Before Use  
Please Save These Instructions!**

July 2014



## Important Warning And Safety Information

-  **WARNING** Read This Manual Thoroughly Before Operating, Installing, Or Performing Maintenance On The Equipment.
-  **WARNING** Failure To Follow Instructions In This Manual Can Cause Property Damage, Injury Or Death.
-  **WARNING** Do Not Store Or Use Gasoline Or Other Flammable Vapors Or Liquids In The Vicinity Of This Or Any Other Appliance.
-  **WARNING** Unless All Cover And Access Panels Are In Place And Properly Secured, Do Not Operate This Equipment.
-  **WARNING** This Appliance Is Not Intended For Use By Persons Who Lack Experience Or Knowledge, Unless They Have Been Given Supervision Or Instruction Concerning Use Of The Appliance By A Person Responsible For Their Safety.
-  **WARNING** This Appliance Is Not To Be Played With.
-  **WARNING** Do Not Clean With Water Jet.
-  **WARNING** Do Not Use Electrical Appliances Inside The Food Storage Compartment Of This Appliance.
-  **CAUTION** Observe the following:
  - Minimum clearances must be maintained from all walls and combustible materials.
  - Keep the equipment area free and clear of combustible material.
  - Allow adequate clearance for air openings.
  - Operate equipment only on the type of electricity indicated on the specification plate.
  - Unplug the unit before making any repairs.
  - Retain this manual for future reference.

## Contents

Receiving And Inspecting Equipment.....	3
Serial Number Information .....	4
Warranty Information.....	4
Regulatory Certifications.....	4
Specifications .....	5
Installation.....	6-7
Operation.....	8
Maintenance.....	8
Wiring Diagram.....	9
Replacement Parts.....	9-10
Standard Labor Guidelines .....	11

## Receiving And Inspecting The Equipment

Even though most equipment is shipped packaged, care should be taken during unloading so the equipment is not damaged while being moved into the building.

1. Visually inspect the exterior of the package and skid or container. Any damage should be noted and reported to the delivering carrier immediately.
2. If damaged, open and inspect the contents with the carrier.
3. In the event that the exterior is not damaged, yet upon opening, there is concealed damage to the equipment notify the carrier. Notification should be made verbally as well as in written form.
4. Request an inspection by the shipping company of the damaged equipment. This should be done within 10 days from receipt of the equipment.
5. Visually inspect the refrigeration package. Be sure lines are secure and base is still intact.
6. Freight carriers can supply the necessary damage forms upon request.
7. Retain all crating material until an inspection has been made or waived.

## Serial Number Information

Models	Serial Tag Location
N225-E, N227-E	On the compressor stand next to the temperature control
203, 204, 204P, 248, 250, 305	On the bottom of the ice chests
240	On the back
242	On the bottom of the sink
307	Underneath the top

Always have the serial number of your unit available when calling for parts or service.

©2014 The Delfield Company. All rights reserved. Reproduction without written permission is prohibited. "Delfield" is a registered trademarks of The Delfield Company.

## Warranty Information

Visit [http://www.delfield.com/minisite/service/warranty\\_info](http://www.delfield.com/minisite/service/warranty_info) to:

- Register your product for warranty.
- Verify warranty information.
- View and download a copy of your warranty.

## Regulatory Certifications

All Models are certified by:



Electrical models are also certified by:



# Specifications

MODEL	L	D	H	SHIP WEIGHT	CUTOUT SIZE	CABINET CAPACITY	H.P.	AMP	VOLT	PLUG	DESIGN LOAD BTU	SYSTEM CAP. BTU	EVAP BTU/ TD/TEMP
<b>DROP-IN FREEZERS</b>													
N225-E	16.56" (42.1cm)	27.87" (70.8cm)	26.75" (67.9cm)	115lbs (52kg)	25.75" x 14.62" (65.4cm x 37.1cm)	6 gal.	1/5	1.1	230-240	CEE 7/7	292	411	20/20°/-23°
N227-E	30" (76.2cm)	27.87" (70.8cm)	26.75" (67.9cm)	191lbs (87kg)	25.75" x 28.00" (65.4cm x 71.1cm)	12 gal.	1/4	1.7	230-240	CEE 7/7	473	532	28/19°/-22
<b>DROP-IN FREEZERS WITH LEXAN® LID</b>													
N225L-E	16.56" (42.1cm)	27.87" (70.8cm)	26.75" (67.9cm)	115lbs (52kg)	25.75" x 14.62" (65.4cm x 37.1cm)	6 gal.	1/5	1.1	230-240	CEE 7/7	292	411	20/20°/-23°
N227L-E	30" (76.2cm)	27.87" (70.8cm)	26.75" (67.9cm)	191lbs (87kg)	25.75" x 28.00" (65.4cm x 71.1cm)	12 gal.	1/4	1.7	230-240	CEE 7/7	473	532	28/19°/-22
<b>DROP-IN WATER STATIONS AND ICE STORAGE</b>													
203	ice chest	20.25" (51.4cm)	20.25" (51.4cm)	23.25" (59.1cm)	52lbs (24kg)	19.25" x 19.25" (48.9cm x 48.9cm)	90lbs (41kg)	N/A	N/A	N/A	N/A	N/A	N/A
204	water and ice station	24" (61.0cm)	21" (53.3cm)	23.5" (59.1cm)	47.5lbs (22kg)	21" x 17.75" (53.3cm x 45.1cm)	45lbs (20kg)	N/A	N/A	N/A	N/A	N/A	N/A
204P	water and ice station	24" (61.0cm)	21" (53.3cm)	27" (68.6cm)	47.5lbs (22kg)	21" x 17.75" (53.3cm x 45.1cm)	45lbs (20kg)	N/A	N/A	N/A	N/A	N/A	N/A
240	ice chest with cover	21" (53.3cm)	17.5" (44.5cm)	17" (43.2cm)	36lbs (16kg)	—	75lbs (34kg)	N/A	N/A	N/A	N/A	N/A	N/A
248	water and ice station	31" (78.7cm)	15" (38.1cm)	22.5" (57.2cm)	28lbs (13kg)	28" x 12.5" (71.1cm x 31.8cm)	45lbs (20kg)	N/A	N/A	N/A	N/A	N/A	N/A
305	ice chest with cover	21.25" (54.0cm)	15.25" (38.7cm)	13" (33.0cm)	18lbs (8kg)	12.5" x 17.75" (31.8cm x 45.1cm)	45lbs (20kg)	N/A	N/A	N/A	N/A	N/A	N/A
307	glass filler	12" (30.5cm)	12" (30.5cm)	9.5" (24.1cm)	7lbs (3kg)	9.00" x 9.00" (23cm x 23cm)	—	N/A	N/A	N/A	N/A	N/A	N/A
<b>UNDERCOUNTER SINKS, WATER STATIONS AND ICE STORAGE</b>													
242	UC sink & faucet	18" (45.7cm)	13.5" (34.3cm)	12.75" (32.4cm)	20lbs (9kg)	17" x 12.5" (43.2cm x 31.8cm)	—	N/A	N/A	N/A	N/A	N/A	N/A
250	UC sink, ice chest and water station	46" (116.8cm)	14.06" (36cm)	22.75" (57.8cm)	81lbs (37kg)	45" x 13" (114.3cm x 33.0cm)	45lbs (20kg)	N/A	N/A	N/A	N/A	N/A	N/A

# Installation - Models N225-E, N225L-E, N227-E And N227L-E

## Location

Units in this manual are intended for indoor use only. The refrigeration system has been factory tested and should require no further adjustment during installation.

For the most efficient refrigeration, be sure to provide good air circulation inside and outside the unit.

**Outside Cabinet:** Be sure that the unit has access to ample air. Avoid hot corners and locations near stoves and ovens.

## Counter Cutouts

For installation provide a cutout in the counter as shown (see illustration 1 or 2). The counter must be sturdy enough to hold the combined weight up to 300 pounds of the drop-in and the product stored inside.

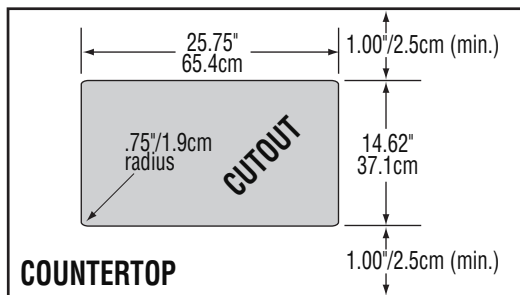

Illustration 1. Model N225-E & N225L-E cutout dimensions

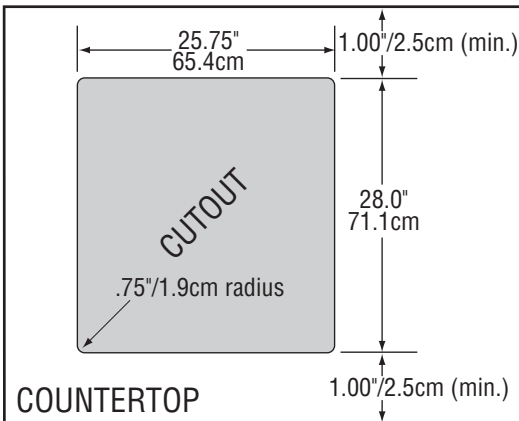
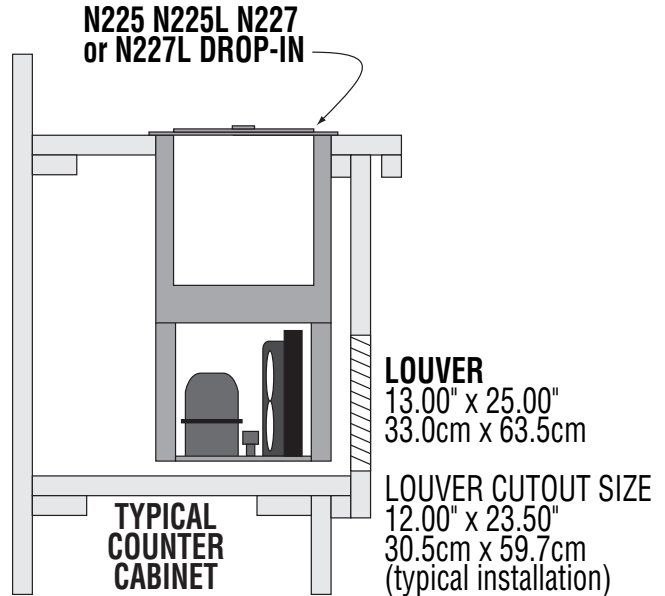

Illustration 2. Model N227-E & N227L-E cutout dimensions



*The louver provided must be installed in front of the condensing unit's finned coil (see illustration 3). A second cutout must be made at the rear or end of the equipment to allow air flow through the unit. No louver is provided for the second cutout. Any restriction to the proper air flow, total or partial, will void the compressor warranty.*



**NOTE:** A second cutout (without louver) must also be made to allow proper air flow.

Illustration 3. N225-E N225L-E N227-E & N227L-E louver installation

## Electrical Connection

Refer to the amperage data, the serial tag, your local code or the National Electrical Code to be sure the unit is connected to the proper power source. A protected circuit of the correct voltage and amperage must be run for connection of the line cord.

If the unit does not operate after it is plugged in, check the thermostat to see if it was inadvertently turned **OFF** during installation.



**The unit must be disconnected from the power source whenever performing service or maintenance functions.**

# Installation - Models 203, 204, 204P, 240, 242, 248, 250, 305 And 307

## Location

Units in this manual are intended for indoor use only. Avoid hot corners and locations near stoves and ovens.

## Counter Cutouts

For installation, provide a cutout in the counter sized according to the chart below. The counter must be sturdy enough to hold the combined weight up to 300 pounds of the drop-in and the product stored inside.

When mounting a 203 ice chest into a wood counter secure it with provided clips. When mounting into a stainless steel counter, use silicone.

## Mounting Studs

Equipment with mounting studs are pictured below. Mark the stud locations according to the measurements or place the equipment in the cutout to mark the stud locations. Drill 0.37" (1.0cm) diameter holes through the counter for the studs.

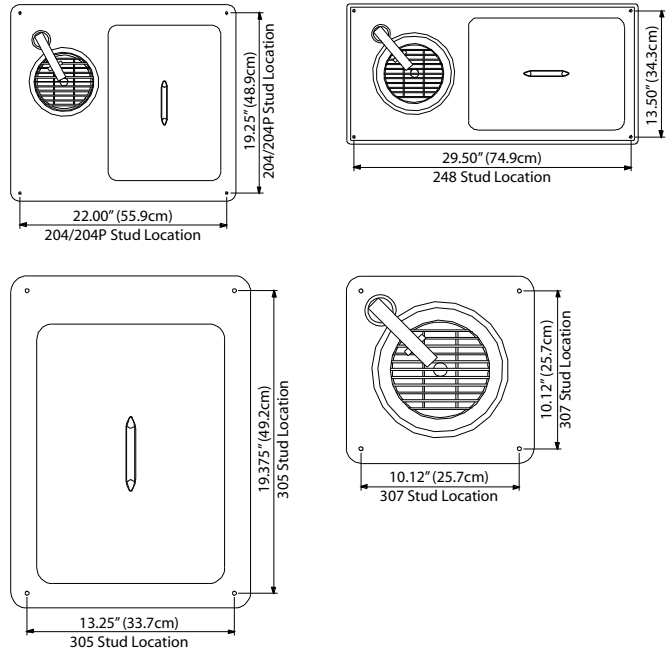

Model Number	Description	Cutout Size	Mounting Studs	1/2" IPS Water Hookup	Drain
203	ice chest	19.25" x 19.25" (49cm x 49cm)	N/A	N/A	(1) 1"
204	water and ice station	21" x 17.75" (53cm x 45cm)	4	1	(2) 1"
204P	water and ice station	21" x 17.75" (53cm x 45cm)	4	1	(2) 1"
240	ice chest with cover	N/A	N/A	N/A	(1) 1"
242	UC sink & faucet	17" x 12.5" (43cm x 32cm)	N/A	2	(1) 1-1/2"
248	water and ice station	28" x 12.5" (71cm x 32cm)	4	1	(2) 1"
250	UC sink, ice chest and water station	45" x 13" (114cm x 33cm)	N/A	3	(2) 1" (1) 1-1/2"
305	ice chest with cover	12.5" x 17.75" (32cm x 45cm)	4	N/A	(1) 1"
307	glass filler	9.00" x 9.00" (23cm x 23cm)	4	1	(1) 1"

## Drain

Provided 1" (2.5cm) drain, nut and washer must be field installed to an appropriate container or floor drain following local code requirements. Sinks come standard with 1-1/2" basket strainer assemblies.

## Water Connection

All 1/2" (1.3cm) IPS water inlets must be field connected following local code requirements.

## Operation - Models N225-E, N225L-E, N227-E And N227L-E

After installation, the unit will begin operating simply by plugging it into the proper outlet. If the unit does not operate after being plugged in, check to see if the thermostat is in the **OFF** position.

The models 225-E and 227-E are designed to hold frozen products at a temperature range of 5°F to -5°F (-15°C to -21°C). The thermostat is located in the machine compartment.

## Maintenance - Models N225-E, N225L-E, N227-E And N227L-E



**Never hose down interior or exterior of units with water. This will void the warranty. Wipe interior dry of any water accumulation.**

In order to maintain proper refrigeration performance, the condenser fins must be cleaned of dust, dirt and grease every three months. If conditions are such that the condenser is totally blocked in three months, the frequency of cleaning should be increased.

Clean the condenser with a vacuum cleaner or stiff brush. If extremely dirty, a commercially available condenser cleaner may be required.

Defrosting must be done manually after 3/8" of ice accumulation. To defrost disconnect power to the equipment or turn the thermostat knob to the **OFF** position.

The lid should be cleaned regularly with a soft cloth or sponge and solution of soap and water to maintain its ability to seal properly.

## Maintenance - Models 203, 204, 204P, 240, 242, 248, 250, 305 And 307



**Never hose down interior or exterior of units with water. This will void the warranty. Wipe interior dry of any water accumulation.**

The interior and exterior of these models may be cleaned using soap and warm water. If this is not sufficient, try ammonia and water or a non-abrasive cleaner. Be sure to rinse thoroughly with clean water after using ammonia or a cleaner. When cleaning the exterior, always rub with the "grain" of the stainless steel to avoid marring the finish.



**Do not use an abrasive cleaner. Abrasive cleaners will scratch the stainless steel and plastic.**



## Wiring Diagram - Models N225-E, N225L-E, N227-E And N227L-E

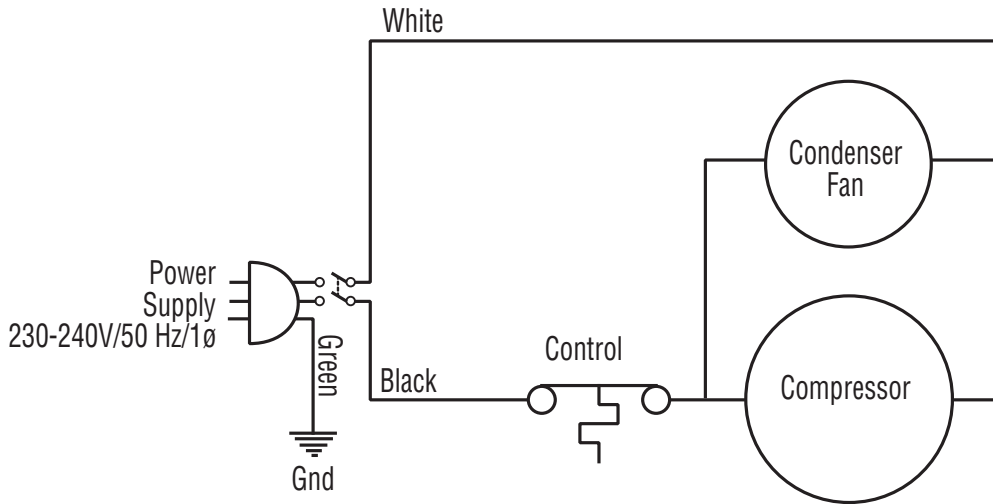

## Replacement Parts - Models N225-E, N225L-E, N227-E And N227L-E

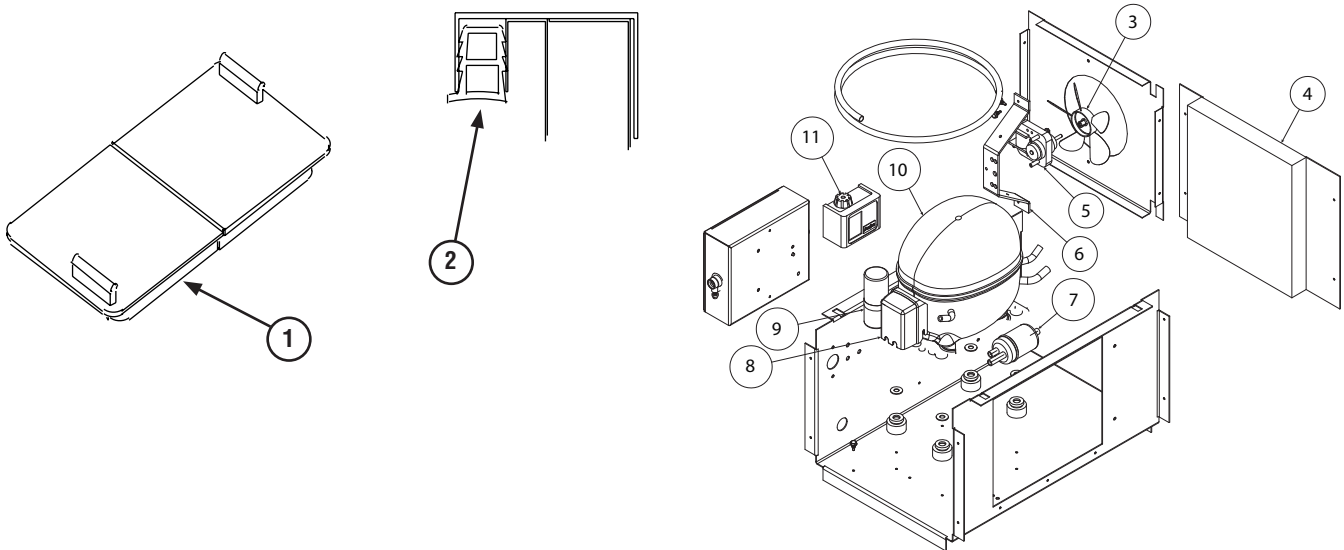

Key	Part No.	Description
1	3234188	Cover (solid)
	3234189	Cover (see-through)
2	1701273	Trim gasket
3	3516172	Fan blade
4	3516067	Condensing coil
5	2162692	Fan motor, 240V, 50/60Hz
6	031-264-0000	Fan motor bracket
7	3516230	Filter dryer, double 1/4" OD inlet, 225-E
	3516322	Filter dryer, 227-E
8	3516452	Compressor relay, 225-E
	3516453	Compressor relay, 227-E

Key	Part No.	Description
9	3516451	Start capacitor
10	3526994	225-E Compressor, 1/5 H.P. 220/50, R404A, TL4CL
	3527013	227-E Compressor, 1/4 H.P. 220/50, R404A, NL7CLX
11	MCP00143	Control Temperature, 227-E
-	Purchase locally	Capillary tube, .031" i.d. 120", 225-E
-	3516596	Expansion Valve, 227-E
-	Varies per destination	Harness, power cord
-	3516324	High pressure cutout
-	359-411-0003	Louvered panel (cutout 12" x 23.5")

# Replacement Parts

## Model 203

- 000-AUO-0030 Removable lid with handle
- 3234110 Lid handle
- 9321406 Lid handle screw
- 3234242 Drain



## Models 204 And 204P

- 3234088 Glass filler 9.5" high, max. ht glass 8"
- 3234303 Pitcher filler 13.5" high, max. ht pitcher 12"
- 3234242 Drain (ice chest and water filler)
- 000-AUO-0030 Removable lid with handle
- 3234110 Lid handle
- 9321406 Lid handle screw
- 3977953 Guard



## Model 240

- 000-AUO-0001 Removable lid
- 3234110 Lid handle
- 9321406 Lid handle screws
- 3234242 Drain



## Model 242

- 3234007 Basket Strainer
- 3234076 Faucet



## Model 248

- 3977953 Guard
- 3234088 Glass filler
- 3234242 Drain
- 000-AUO-0030 Removable lid
- 3234110 Lid handle
- 9321406 Lid handle screw

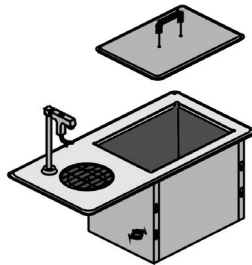

## Model 250

- 3234007 Basket strainer
- 3234076 Faucet
- 000-AUO-0030 Removable lid
- 3234110 Lid handle
- 9321406 Lid handle screw
- 3234088 Glass filler
- 3234242 Drain
- 3977953 Guard



## Model 305

- 3234242 Drain
- 000-AUO-0030 Removable lid
- 3234110 Lid handle
- 9321406 Lid handle screw



## Model 307

- 3234088 Glass filler 9.5" high, max. ht glass 8"
- 3977953 Guard
- 3234242 Drain



## Standard Labor Guidelines To Repair Or Replace Parts On Delfield Equipment

Advice and recommendations given by Delfield Service Technicians do not constitute or guarantee any special coverage.

- A maximum of 1-hour is allowed to **diagnose a defective component**.
- A maximum **travel distance** of 100 miles round trip and 2-hours will be reimbursed. Actual travel to be charged.
- Overtime, installation/start-up, normal control adjustments, general maintenance, glass breakage, freight damage, and/or correcting and end-user installation error will not be reimbursed under warranty unless pre-approved with a **Service Work Authorization** from Delfield. You must submit the number with the service claim.
- Actual repair time will be paid at or below guideline.
- Parts on the critical stock list must be air freighted at the expense of the service agent.

### Labor Up To 1-Hour Is Allowed To Replace

- |  |  |
|--|--|
| • Infinite Switch                                    | • Contactor/Relay                          |
| • Door Jamb Switch                                   | • Transformer                              |
| • Solenoid Coil                                      | • Evaporator/Condenser Fan Motor and Blade |
| • Hi-limit/Thermal Protector Switch                  | • Circulating Fan Motor and Blade          |
| • Fan Delay/Defrost Termination Switch               | • Digital Control                          |
| • Compressor Start Components and Overload Protector | • Water Level Sensor/Probe                 |
| • Defrost Timer                                      | • Door Hinges, Locks, and Gaskets          |
| • Thermostat   | • Condensate Element                       |
| • Thermometer  | • Springs/Lowerator                        |
| • Gear Motor   |  |

### Labor Up To 2 Hours To Replace

- |                            |                      |
|----------------------------|----------------------|
| • Drawer Tracks/Cartridges | • Defrost Element    |
| • Pressure Control         | • Heating Element    |
| • Solenoid Valve           | • Locate/Repair Leak |

### Labor Up To 3 Hours To Replace

- |                    |                                |
|--------------------|--------------------------------|
| • EPR or CPR Valve | • Condenser or Evaporator Coil |
| • Expansion Valve  | • Cap Tube                     |

### Labor Up To 4 Hours To Replace

- Compressor
  - This includes recovery of refrigerant and leak check.
  - \$55.00 maximum reimbursement for refrigerant recovery (includes recovery machine, pump, torch, oil, flux, minor fittings, solder, brazing rod, nitrogen, or similar fees).

### Refrigerants

- R22 A maximum of \$4.00/lb. or 25¢/oz. will be reimbursed.
- R134A A maximum of \$7.00/lb. or 44¢/oz. will be reimbursed.
- R404A A maximum of \$16.00/lb. or \$1.00/oz. will be reimbursed.



***Mt. Pleasant, MI***



***Covington, TN***

*Thank you for choosing Delfield!*

Help is a phone call away. Help our team of professional, courteous customer service reps by having your model number and serial number available at the time of your call (800) 733-8829.

Model: \_\_\_\_\_ S/N: \_\_\_\_\_

Installation Date: \_\_\_\_\_



For a list of Delfield's authorized parts depots, visit our website at [www.delfield.com](http://www.delfield.com)

Register your Delfield warranty online. Go to [www.delfield.com](http://www.delfield.com) under the service tab to complete.

