

Compact Refrigerators & Freezers

400 & 4000 Series

Original Instructions

Installation, Operation and Maintenance Manual

This manual is updated as new information and models are released. Visit our website for the latest manual.



Safety Notices

⚠ Warning

Read this manual thoroughly before operating, installing or performing maintenance on the equipment. Failure to follow instructions in this manual can cause property damage, injury or death.

⚠ DANGER

Do not install or operate equipment that has been misused, abused, neglected, damaged, or altered/modified from that of original manufactured specifications.

⚠ DANGER

Keep power cord AWAY from HEATED surfaces. DO NOT immerse power cord or plug in water. DO NOT let power cord hang over edge of table or counter.

⚠ DANGER

All utility connections and fixtures must be maintained in accordance with Local and national codes.

⚠ Warning

Authorized Service Representatives are obligated to follow industry standard safety procedures, including, but not limited to, local/national regulations for disconnection / lock out / tag out procedures for all utilities including electric, gas, water and steam.

⚠ Warning

Do not store or use gasoline or other flammable vapors or liquids in the vicinity of this or any other appliance. Never use flammable oil soaked cloths or combustible cleaning solutions, for cleaning.

⚠ Warning

This product contains chemicals known to the State of California to cause cancer and/or birth defects or other reproductive harm. Operation, installation, and servicing of this product could expose you to airborne particles of glasswool or ceramic fibers, crystalline silica, and/or carbon monoxide. Inhalation of airborne particles of glasswool or ceramic fibers is known to the State of California to cause cancer. Inhalation of carbon monoxide is known to the State of California to cause birth defects or other reproductive harm.

⚠ Warning

Do not use electrical appliances or accessories other than those supplied by the manufacturer.

⚠ Warning

Use caution when handling metal surface edges of all equipment.

⚠ Warning

This appliance is not intended for use by persons (including children) with reduced physical, sensory or mental capabilities, or lack of experience and knowledge, unless they have been given supervision concerning use of the appliance by a person responsible for their safety. Do not allow children to play with this appliance.

⚠ Caution

Use caution handling, moving and use of the R290 refrigerators to avoid either damaging the refrigerant tubing or increasing the risk of a leak. Components shall be replaced with like components. Servicing shall be done by a factory authorized service personnel to minimize the risk of possible ignition due to incorrect parts or improper service.

Notice

Proper installation, care and maintenance are essential for maximum performance and trouble-free operation of your equipment. Visit our website www.mtwtchencare.com for manual updates, translations, or contact information for service agents in your area.

Table of Contents

Section 1 General Information

Model Numbers	4
Serial Number Location	4
Warranty Information	4
Regulatory Certifications	4

Section 2 Installation

Location	5
Weight of Equipment	6
Clearance Requirements.....	6
Dimensions	6
Electrical Service	7
Voltage	7
Ground Fault Circuit Interrupter	7
Rated Amperages, Horsepower, Voltage & Power Cord Chart.....	7
Refrigeration	7
Drain Connections.....	7
Caster Or Leg Installation	8
Leg Leveling	8
Caster and Leg Mounting Detail.....	9
Loosen Freezer Compressor Bolts.....	9

Section 3 Operation

Controls/Programming/Settings	11
R404A Refrigerators.....	11
R290 Refrigerators.....	11
Freezers	12
Evaporator Fan Operation.....	12

Section 4 Maintenance

Interior Cleaning	14
Preventing Blower Coil Corrosion	14
Exterior Cleaning.....	14
Drain.....	14
Cleaning the Condenser Coil	14
Doors/Hinges.....	14

Section 5 Troubleshooting

Problem -> Cause -> Correction Chart.....	15
---	----

Section 1

General Information

Model Numbers

This manual covers standard units only.

NOTE: For custom units, consult Manitowoc KitchenCare at 1-844-724-CARE.

Work Top Refrigerator Bases With Stainless Steel Top & Backsplash	
402P	ST4048P

Undercounter Refrigerator Bases With Stainless Steel Top	
406P	UC4048P

Undercounter Refrigerator With Subtop And 3.75" Casters	
406CAP	

The prefix P on a model number indicates the use of the refrigerant propane.

Undercounter Freezer Base With Stainless Steel Top	
407	

Undercounter Freezer With Subtop And 3.75" Casters	
407CA	

Serial Number Location

The serial number on 400 series compact refrigerators and freezers is printed on the right side of the interior back wall.

The serial tag on 4000 series compact refrigerators and freezers is located either on the left upper sidewall inside the cabinet or under the top nosing directly above the door when the door is in the closed position (right hand door when there are two doors).

Always have the serial number of your unit available when calling for parts or service.

Warranty Information

Visit

<http://www.delfield.com/warranty> to:

- Register your product for warranty.
- Verify warranty information.
- View and download a copy of your warranty.

Regulatory Certifications

Models are certified by:

- National Sanitation Foundation (NSF)
- Underwriters Laboratories (UL)
- Underwriters Laboratories of Canada (cUL)

Section 2 Installation

⚠ DANGER

Installation must comply with all applicable fire and health codes in your jurisdiction.

⚠ DANGER

Use appropriate safety equipment during installation and servicing

⚠ Warning

Remove all removable panels before lifting and installing.

⚠ Warning

Do not damage the refrigeration circuit when installing, maintaining or servicing the unit.

Location

⚠ Warning

This equipment must be positioned so that the plug is accessible unless other means for disconnection from the power supply (e.g., circuit breaker or disconnect switch) is provided.

⚠ Warning

Adequate means must be provided to limit the movement of this appliance without depending on or transmitting stress to the electrical conduit or gas lines.

⚠ Warning

To avoid instability the installation area must be capable of supporting the combined weight of the equipment and product. Additionally the equipment must be level side to side and front to back.

⚠ Warning

This equipment is intended for indoor use only. Do not install or operate this equipment in outdoor areas.

⚠ Caution

Do not position the air intake vent near steam or heat exhaust of another appliance.

The location selected for the equipment must meet the following criteria. If any of these criteria are not met, select another location.

- Units are intended for indoor use only.
- The location **MUST** be level, stable and capable of supporting the weight of the equipment.
- The location **MUST** be free from and clear of combustable materials.
- Equipment **MUST** be level both front to back and side to side.
- Position the equipment so it will not tip or slide.
- Front casters **MUST** be locked once positioned.
- Recommended air temperature is 41° - 86°F (5° - 30°C).
- Proper air supply for ventilation is **REQUIRED AND CRITICAL** for safe and efficient operation. Refer to Clearance Requirements chart on page 6.
- Do not obstruct the flow of ventilation air. Make sure the air vents of the equipment are not blocked.
- Do not install the equipment directly over a drain. Steam rising up out of the drain will adversely affect operation, air circulation, and damage electrical / electronic components.

Weight of Equipment

Model	Weight
402P	176lbs (80kg)
406P	176lbs (80kg)
406CAP	168lbs (76kg)
407	176lbs (80kg)
407CA	168lbs (76kg)
ST4048P	234lbs (106kg)
UC4048P	236lbs (107kg)

Clearance Requirements

DANGER

Minimum clearance requirements are the same for noncombustible locations as for combustible locations. The flooring under the appliance must be made of a noncombustible material.

DANGER

Risk of fire/shock. All minimum clearances must be maintained. Do not obstruct vents or openings.

Back	3.00" (76mm)
Top / Sides	1.00" (25mm)
Bottom	2.00" (51mm)

- Keep the vents clean and free of obstruction.
- Legs or casters must be used and not removed.

Dimensions

Model	Length	Depth	Height
402P	27" (69cm)	28.5" (72cm)	39.5" (100cm)
406P	27" (69cm)	28.5" (72cm)	35.5" (90cm)
406CAP	27" (69cm)	27.75" (70cm)	33.25" (84cm)
407	27" (69cm)	28.5" (72cm)	35.5" (90cm)
407CA	27" (69cm)	27.75" (70cm)	33.25" (84cm)
ST4048P	48" (122cm)	28.5" (72cm)	39.5" (100cm)
UC4048P	48" (122cm)	28.5" (72cm)	35.5" (90cm)

Model	Volume	Shelf Space
402P 406P 406CAP 407 407CA	5.7Ft ³ (161L)	4.6Ft ² (43dm ²)
ST4048P UC4048P	10.80Ft ³ (306L)	8.0Ft ² (74dm ²)

Electrical Service

⚠ DANGER
 Check all wiring connections, including factory terminals, before operation. Connections can become loose during shipment and installation.

⚠ DANGER
 Units with two power cords must be plugged into individual branch circuits. During movement, cleaning or repair it is necessary to unplug both power cords.

⚠ Warning
 This appliance must be grounded and all field wiring must conform to all applicable local and national codes. Refer to rating plate for proper voltage. It is the responsibility of the end user to provide the disconnect means to satisfy the authority having jurisdiction.

VOLTAGE

All electrical work, including wire routing and grounding, must conform to local, state and national electrical codes.

The following precautions must be observed:

- The equipment must be grounded.
- A separate fuse/circuit breaker must be provided for each unit.
- The maximum allowable voltage variation is $\pm 10\%$ of the rated voltage at equipment start-up (when the electrical load is highest).
- Check all green ground screws, cables and wire connections to verify they are tight before start-up.

GROUND FAULT CIRCUIT INTERRUPTER

Ground Fault Circuit Interrupter (GFCI/GFI) protection is a system that shuts down the electric circuit (opens it) when it senses an unexpected loss of power, presumably to ground. Welbilt does not recommend the use of GFCI/GFI circuit protection to energize our equipment. If code requires the use of a GFCI/GFI then you must follow the local code. The circuit must be dedicated, sized properly and there must be a panel GFCI/GFI breaker. We do not recommend the use of GFCI/GFI outlets to energize our equipment as they are known for more intermittent nuisance trips than panel breakers.

RATED AMPERAGES, HORSEPOWER, VOLTAGE & POWER CORD CHART

Units with plugs are supplied with approximately 6ft (183cm) cords.

Models 406 and 407 may be stacked using a stacking collar. In this case two 6ft (183cm) long grounded supply cords and plugs are standard.

Model	Amps	HP	Voltage, Cycle, Phase	NEMA Plug
402P	4.0	1/5	115/60/1	5-15P
406P	4.0			
406CAP	4.0			
407	5.8			
407CA	5.8			
ST4048P	4.0	1/5		
UC4048P	4.0			

Refrigeration

Model	BTU/Hour Capacity	Heat of Rejection	Refrig Charge
402P	1356	210	100g R290
406P	1356	210	100g R290
406CAP	1356	210	100g R290
407	800	339	6.5oz R404A
407CA	800	339	6.5oz R404A
ST4048P	1356	316	100g R290
UC4048P	1356	316	100g R290

Drain Connections

⚠ Warning
 If a refrigerated base does not have a condensate evaporator supplied, you must connect the condensate line to a suitable drain. Otherwise, water will collect on the floor, causing a potentially hazardous situation.

⚠ Warning
 Moisture collecting from improper drainage can create a slippery surface on the floor and a hazard to employees. It is the owner's responsibility to provide a container or outlet for drainage.

Caster Or Leg Installation

⚠ DANGER

Legs or casters must be installed and the legs or casters must be screwed in completely to prevent bending. When casters are installed the mass of this unit will allow it to move uncontrolled on an inclined surface. These units must be tethered/secured to comply with all applicable codes.

⚠ Warning

The unit must be installed in a stable condition with the front wheels locked. Locking the front casters after installation is the owner's and operator's responsibility.

⚠ Warning

Use a jack to lift the refrigeration unit off the ground just far enough to remove the leg/caster. Place blocking underneath the unit. Do not work underneath a raised unit without proper blocking. Do not lift the unit more than necessary to remove the leg/caster. Lifting the unit too far can make the unit unstable.

⚠ Caution

All single-section units require that the swivel casters be mounted on the front and rigid casters be mounted on the rear.

1. Carefully place the unit on its back.
2. Located at each caster mounting location are 4 Phillips head screws, for a total of 16 screws. Remove them.
3. Place a locking plate caster or leg over one of the front holes, matching the 4 mounting holes to the pre-drilled holes in the underside of the unit. Insert 4 Phillips head screws and tighten. Repeat with the other locking front caster or leg.
4. Repeat step 3 with the non-locking casters or legs in the rear of the unit.
5. Carefully lift the unit upright.

⚠ Caution

After installing casters, the unit must stand upright for twenty-four (24) hours before being powered up to assure oil return to the compressor sump.

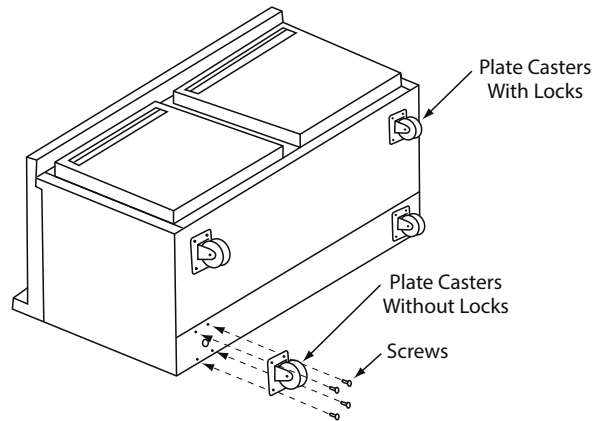

LEG LEVELING

All four legs are adjustable. Adjust each leg until the unit is stable and level left to right. If necessary adjusting the front legs slightly higher than the rear by about 1/8" (3mm) will help the door remain closed.

CASTER AND LEG MOUNTING DETAIL

A universal bolt hole pattern is provided on the bottom of the cabinet. It will accommodate any leg or caster. Simply line up the plate holes with the corresponding cabinet holes.

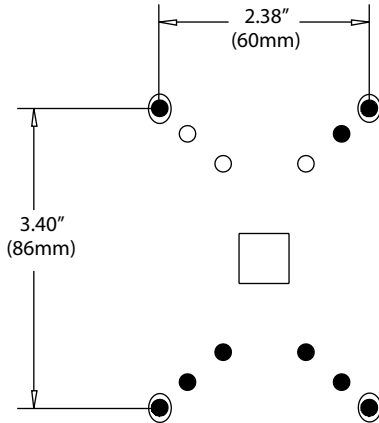

NOTE: If hole pattern on caster/leg matches the one above mount in outer set of holes.

- 6" Leg - 3234569

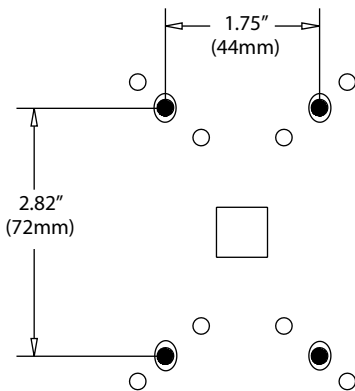

NOTE: If hole pattern on caster/leg matches the one above mount in middle set of holes.

- 3" Caster - 3234024
- 5" Caster - 3234161
- 6" Leg - 3234791

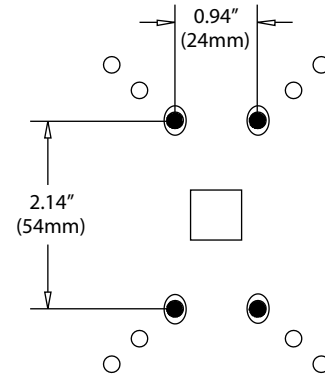

NOTE: If hole pattern on caster/leg matches the one above mount in inner set of holes.

- 2" Caster - 3234148

Loosen Freezer Compressor Bolts

Semi hermetic models should be loosened before operating. Loosen (but do not remove) the bolts on the compressor. If not done the freezer may vibrate excessively when the compressor is running,

Section 3 Operation

DANGER

The on-site supervisor is responsible for ensuring that operators are made aware of the inherent dangers of operating this equipment.

DANGER

Do not operate any appliance with a damaged cord or plug. All repairs must be performed by a qualified service company.

DANGER

Never stand on the unit! They are not designed to hold the weight of an adult, and may collapse or tip if misused in this manner.

Warning

Do not contact moving parts.

Warning

All covers and access panels must be in place and properly secured, before operating this equipment.

Warning

Do not use electrical appliances inside the food storage compartment of this appliance.

Warning

The operator of this equipment is solely responsible for ensuring safe holding temperature levels for all food items. Failure to do so could result in unsafe food products for customers.

Warning

Overloading shelves can damage equipment or cause bodily injury.

Warning

Damp or wet hands may stick to cold surfaces.

Warning

Do not block the supply and return air grills or the air space around the air grills. Keep plastic wrappings, paper, labels, etc. from being airborne and lodging in the grills. Failure to keep the air grills clear will result in unsatisfactory operation of the system.

Caution

Do not throw items into the storage area. Failure to heed this recommendation could result in damage to the interior of the cabinet or to the blower coil.

Controls/Programming/Settings

R404A REFRIGERATORS

After the unit is connected to power it will automatically begin operating. With the doors closed, the temperature of the cabinet should reach 36°F to 40°F (2°C to 4°C) on refrigerators in about one hour.

A thermostat located in the evaporator housing on interior rear of the unit, controls the temperature in the box. The factory setting for the control is 4 and maintains about 38°F (3°C) in the box. Set toward 1 for higher temperatures and toward 7 for lower temperatures.

Refrigerators defrost automatically with every cycle of the compressor. The water generated is routed to a pan on the rear of the unit and is evaporated by the heat given off by the compressor.

During normal operation the evaporator fan may cycle and/or pulse independently of the compressor. Consult the service manual or contact Technical Support at 1-844-724-CARE if you are unsure of the proper function.

R290 REFRIGERATORS

At initial start-up or anytime power is disconnected, then reconnected to the unit, the control will delay all operations for a short time (up to 30 minutes.) While in this delay period the control will initialize.

With the doors closed, the temperature of the cabinet should reach 36°F to 40°F (2°C to 4°C) on refrigerators in about one hour. The electronic temperature control constantly monitors box temperature and evaporator coil temperature to maintain consistent product temperatures.

Refrigerators periodically go into defrost to allow the accumulated frost on the evaporator to clear, the compressor and condenser fan motor will turn off when the temperature control detects a certain evaporator temperature. After the defrost cycle is complete, the temperature control will return to a normal cooling cycle. The water generated is routed to a pan on the rear of the unit and is evaporated by the heat given off by the compressor.

During normal operation the evaporator fan may cycle and/or pulse independently of the compressor. Consult the service manual or contact Technical Support at 1-844-724-CARE if you are unsure of the proper function.

Electronic Temperature Control Location & Adjustment

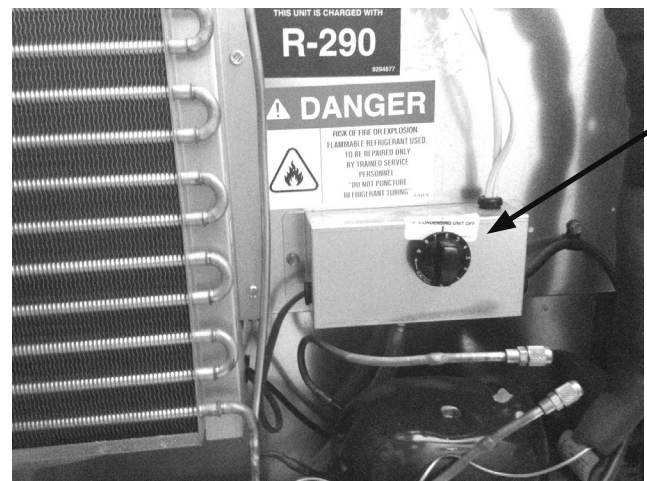

Rear View Of R290 Refrigerator

The control is located in the control box at the rear of the unit. **Never turn the knob more than one dial number and always allow eight hours for temperature stabilization before making any additional adjustments.** To adjust for colder temperatures, turn the knob clockwise. For warmer temperatures, turn the knob counter-clockwise. Turn the knob fully counter-clockwise to turn the refrigeration system off.

FREEZERS

This unit does not have a power switch, plug the unit in to begin operation. At initial start-up or anytime power is disconnected, then reconnected to the unit, the control will delay all operations for a short time (up to 40 minutes). While in this delay period, the control initializes the control parameters and confirms that the temperature sensors and circuits are operational.

After initializing, the control will immediately enter a DEFROST mode. The compressor and condenser fan as well as the evaporator fan will remain off until initial defrost is complete. This initial defrost cycle may take up to 15 minutes to complete, then the freezing cycle will begin.

After initializing and the defrost cycle, the electronic temperature control will cycle the compressor, evaporator fan motor, and condenser fan motor to maintain box temperature at the control setting.

With the doors closed, the temperature of the cabinet should reach 0°F (-18°C) on freezers in about one hour after the freezing cycle begins. The electronic temperature control constantly monitors box temperature as well as evaporator coil temperature to maintain consistent product temperatures. As an added energy-saving feature, the electronic controller will switch the evaporator fan motor on and off with the compressor and condenser fan motor.

During normal operation the evaporator fan may cycle and/or pulse independently of the compressor. Consult the service manual or contact Technical Support at 1-844-724-CARE if you are unsure of the proper function.

Electronic Temperature Control Location & Adjustment

Never turn the knob more than one dial number and always allow eight hours for temperature stabilization before making any additional adjustments. The control is located in the control box at the rear of the unit. It is factory set at mid-range to maintain about -3°F (-18°C) box temperature. To adjust for colder temperatures, turn the knob clockwise. For warmer temperatures, turn the knob counter-clockwise. Turn the knob fully counter-clockwise to turn the refrigeration system off.

Freezer Automatic Defrost

The control also monitors compressor total running time and will enter a defrost cycle after total compressor running time is greater than five hours since the last defrost cycle OR if evaporator coil temperature drops below -34°F (-37°C) (indicating excessive frost on the coil).

Freezer Manual Defrost

If a manual defrost is desired, simply unplug the unit for several seconds, then plug unit back in. This will cause the control to re-initialize and then enter a defrost cycle.

When the control enters the defrost mode, whether manual or automatic, it switches off the evaporator fan motor, compressor and condenser fan motor, and switches on the defrost heater to warm the evaporator coil and melt all frost accumulated during the previous refrigeration cycle. The control will continue the defrost cycle for a MINIMUM of eight minutes and a MAXIMUM of 30 minutes depending on the amount of frost accumulated on the evaporator coil.

After the defrost cycle is complete, the control returns to a normal refrigeration cycle, however the evaporator fan motor will not switch on for two minutes AFTER the compressor and condenser fan motor have begun operating.

EVAPORATOR FAN OPERATION

	Cooling Cycle		Defrost Cycle
	Compressor On	Compressor Off	Compressor Off
	Evap Fan	Evap Fan	Evap Fan
R404A Refrigerators	On	On	On
R290 Refrigerators	On	Cycles On 3-Min Off 3Min	On
Freezer	On	Off	Off

Section 4 Maintenance

⚠ DANGER

It is the responsibility of the equipment owner to perform a Personal Protective Equipment Hazard Assessment to ensure adequate protection during maintenance procedures.

⚠ DANGER

Failure to disconnect the power at the main power supply disconnect could result in serious injury or death. The power switch DOES NOT disconnect all incoming power.

⚠ DANGER

Disconnect electric power at the main power disconnect for all equipment being serviced. Observe correct polarity of incoming line voltage. Incorrect polarity can lead to erratic operation.

⚠ Warning

Never use sharp objects or tools to remove ice or frost. Do not use mechanical devices or other means to accelerate the defrosting process.

⚠ Warning

When using cleaning fluids or chemicals, rubber gloves and eye protection (and/or face shield) must be worn.

⚠ Warning

When cleaning interior and exterior of unit, care should be taken to avoid the front power switch and the rear power cord. Keep water and/or cleaning solutions away from these parts.

⚠ Warning

Never use a high-pressure water jet for cleaning or hose down or flood interior or exterior of units with water. Do not use power cleaning equipment, steel wool, scrapers or wire brushes on stainless steel or painted surfaces.

⚠ Caution

Maintenance and servicing work other than cleaning as described in this manual must be done by an authorized service personnel.

⚠ Caution

Over shelves and other items mounted to the top of the counters should never be installed in the field due to the potential damage to the refrigeration system.

Responsibility

You are responsible for maintaining the equipment in accordance with the instructions in this manual. Maintenance procedures are not covered by the warranty.

Maintenance	Daily	Weekly	Monthly	After Prolonged Shutdown	At Start-Up
Interior	X			X	X
Gasket	X		X	X	X
Exterior	X			X	X
Drain		X		X	X
Condenser Coil			X	X	X
Casters			X	X	X

Interior Cleaning

The interior can be cleaned using soap and warm water. If this isn't sufficient, try ammonia and water or a nonabrasive liquid cleaner.

PREVENTING BLOWER COIL CORROSION

To help prevent corrosion of the blower coil, store all acidic items, such as pickles and tomatoes, in seal-able containers. Immediately wipe up all spills.

Exterior Cleaning

⚠ Caution

Never use an acid based cleaning solution on exterior panels! Many food products have an acidic content, which can deteriorate the finish. Be sure to clean the stainless steel surfaces of ALL food products.

Clean the area around the unit as often as necessary to maintain cleanliness and efficient operation.

Wipe gasket and surfaces with a damp cloth rinsed in water to remove dust and dirt from the outside of the unit. Always rub with the "grain" of the stainless steel to avoid marring the finish. If a greasy residue persists, use a damp cloth rinsed in a mild dish soap and water solution. Wipe dry with a clean, soft cloth.

Never use steel wool or abrasive pads for cleaning. Never use chlorinated, citrus based or abrasive cleaners.

Stainless steel exterior panels have a clear coating that is stain resistant and easy to clean. Products containing abrasives will damage the coating and scratch the panels. Daily cleaning may be followed by an application of stainless steel cleaner which will eliminate water spotting and fingerprints. Early signs of stainless steel breakdown are small pits and cracks. If this has begun, clean thoroughly and start to apply stainless steel cleaners in attempt to restore the steel.

Wipe casters with a damp cloth monthly to prevent corrosion.

DRAIN

Each unit has a drain located inside the unit that removes the condensation from the evaporator coil and routes it to an external condensate evaporator pan. Each drain can become loose or disconnected during normal use. If you notice water accumulation on the inside of the unit, be sure the drain tube is connected to the evaporator drain pan. If water is collecting underneath the unit, make sure the end of the drain tube is in the condensate evaporator. The leveling of the unit is important as the units are designed to drain properly when level. Be sure all drain lines are free of obstructions.

Cleaning the Condenser Coil

In order to maintain proper refrigeration performance, the condenser fins must be cleaned of dust, dirt and grease regularly. It is recommended that this be done monthly. If conditions are such that the condenser is totally blocked in a month, the frequency of cleaning should be increased. Clean the condenser with a vacuum cleaner or stiff brush. If extremely dirty, a commercially available condenser cleaner may be required.

Failure to maintain a clean condenser coil can initially cause high temperatures and excessive run times. Continuous operation with a dirty or clogged condenser coil can result in compressor failure. Neglecting the condenser coil cleaning procedures will void any warranties associated with the compressor and cost to replace the compressor.

Doors/Hinges

Over time and with heavy-use doors, the hinges may become loose. If this happens, tighten the screws that mount the hinge brackets to the frame of the unit. Loose or sagging doors can cause the hinges to pull out of the frame, which may damage both the doors and the hinges. In some cases this may require qualified service agents or maintenance personnel to perform repairs.

Door Adjustment

If the door needs lowering at the handle, use a 5/16" (8mm) wrench to loosen the hinge screws and install a spacer outside of the hinge. Tighten the screws.

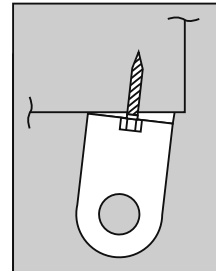

If the door needs to be higher at the handle, use a 5/16" (8mm) wrench to loosen the hinge screws and install a spacer inside of the hinge. Tighten the screws.

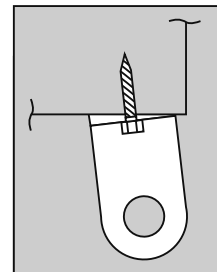

Section 5 Troubleshooting

Problem -> Cause -> Correction Chart

Problem	Cause	Correction
Cabinet not running	Fuse blown or circuit breaker tripped.	Replace fuse or reset circuit breaker.
	Power cord unplugged.	Plug in power cord.
	Thermostat set too high.	Set thermostat to lower temperature.
	Main power switch turned off.	Turn main power switch on.
	Cabinet in defrost cycle. (Freezer models)	Wait for defrost cycle to finish.
Condensing unit runs for long periods or continuously	Excessive amount of warm product placed in cabinet.	Allow adequate time for product to cool down.
	Prolonged door openings or door(s) ajar.	Make sure door(s) are closed when not in use. Avoid prolonged door openings.
	Door gasket(s) not sealing properly.	Check gasket condition. Adjust door or replace gasket if necessary.
	Dirty condenser coil.	Clean the condenser coil.
	Evaporator coil iced over.	Turn unit off and allow coil to defrost. Make sure thermostat is not set too cold. Also, check gasket condition.
Cabinet temperature is too high	Thermostat set too high.	Set thermostat to lower temperature.
	Poor air circulation in cabinet.	Re-arrange product to allow proper air circulation.
	Exterior thermometer is out of calibration.	Re-calibrate thermometer.
	Excessive amount of warm product placed in cabinet.	Allow adequate time for product to cool down.
	Prolonged door openings or door(s) ajar.	Make sure door(s) are closed when not in use. Avoid prolonged door openings.
	Dirty condenser coil.	Clean the condenser coil.
	Evaporator coil iced over.	Turn unit off and allow coil to defrost. Make sure thermostat is not set too cold. Also, check gasket condition.
Cabinet is noisy	Loose part(s).	Locate and tighten loose part(s).
Refrigerator is freezing product	Thermostat is set too low.	Set thermostat to higher temperature.
	Dirty condenser coil.	Clean the condenser coil.
	Not enough cabinet clearance for proper refrigeration system operation.	Move cabinet or make other adjustments to gain proper cabinet clearances.
Compressor will not start	Low voltage to cabinet.	Check and correct incoming voltage to cabinet.

**WWW.WELBILT.COM**

Welbilt provides the world's top chefs, and premier chain operators or growing independents with industry leading equipment and solutions. Our cutting-edge designs and lean manufacturing tactics are powered by deep knowledge, operator insights, and culinary expertise. All of our products are backed by KitchenCare® – our aftermarket, repair, and parts service.

- ▶ CLEVELAND
- ▶ CONVOTHERM®
- ▶ DELFIELD®
- ▶ FITKITCHEN™
- ▶ FRYMASTER®
- ▶ GARLAND
- ▶ KOLPAK®
- ▶ LINCOLN
- ▶ MANITOWOC®
- ▶ MERCO®
- ▶ MERRYCHEF®
- ▶ MULTIPLEX®