



## **536-SR68 & 536-SRR68 Dual View Display Case**

### **Service, Installation and Care Manual**

Please read this manual completely before attempting to install or operate this equipment! Notify carrier of damage! Inspect all components immediately. See page 2.



**536-SR68**



**IMPORTANT INFORMATION  
READ BEFORE USE  
PLEASE SAVE THESE INSTRUCTIONS!**

Effective Date June 2008  
Enodis®

Contents	Serial Number Location
Serial Number Location . . . . .	2
Receiving and Inspecting the Equipment. . . . .	2
Specifications. . . . .	2
Installation . . . . .	3
Operation . . . . .	3
Display Case Glass Replacement. . . . .	3
Maintenance. . . . .	4
Pressure Control Settings . . . . .	5
Wiring Diagram . . . . .	5
Replacement Parts Lists . . . . .	6
Standard Warranties. . . . .	7-9

The serial number is located on the rear of the unit on the bottom right hand side.

Always have the serial number available when calling for parts or service.

©2008 The Delfield Company. All rights reserved. Reproduction without written permission is prohibited. "Delfield" is a registered trademark of The Delfield Company.

## Receiving And Inspecting The Equipment

Even though most equipment is shipped crated, care should be taken during unloading so the equipment is not damaged while being moved into the building.

1. Visually inspect the exterior of the package and skid or container. Any damage should be noted and reported to the delivering carrier immediately.
2. If damaged, open and inspect the contents with the carrier.
3. In the event that the exterior is not damaged, yet upon opening, there is concealed damage to the equipment notify the carrier. Notification should be made verbally as well as in written form.
4. Request an inspection by the shipping company of the damaged equipment. This should be done within 10 days from receipt of the equipment.

5. Also open the compressor compartment housing and visually inspect the refrigeration package. Be sure lines are secure and base is still intact.
6. Freight carriers can supply the necessary damage forms upon request.
7. Retain all crating material until an inspection has been made or waived.

### Uncrating the Equipment

First cut and remove the banding from around the crate. Remove the front of the crate material, use of some tools will be required.



**Warning: While uncrating do not lay unit on side. If compressor is set on side, return to upright position for 24 hours to allow for all compressor oil to drain back into compressor.**

## Specifications

Model	Length	Overall Depth	Height	Shelf Area	Storage Capacity	Design Load	H.P.	Volts	Amps	NEMA Plug	Ship Weight
536-SR68	36" (91.4cm)	28" (71.1cm)	68" (172.7cm)	19.9ft <sup>2</sup>	21.8ft <sup>3</sup>	1286	1/2	120	12.0	5-15P	600lbs/272kg
536-SRR68	36" (91.4cm)	28" (71.1cm)	68" (172.7cm)	19.9ft <sup>2</sup>	21.8ft <sup>3</sup>	1286	N/A	120	5.0	N/A	575lbs/261kg

## Installation

### Location

These units are intended for indoor use only. Be sure the location chosen has a floor strong enough to support 1000 pounds of the cabinet and contents. Reinforce the floor as necessary to provide for maximum loading.

For the most efficient refrigeration, be sure to provide good air circulation inside and out.

**Inside cabinet:** Do not pack refrigerator so full that air cannot circulate.

**Outside cabinet:** Be sure that the unit has access to ample air. Avoid hot corners and locations near stoves and ovens.

### Leveling

A level cabinet looks better and will perform better because:

1. The drain pan will drain properly.
2. The doors will line up with the frames properly.
3. The cabinet will not be subject to undue strain.



**To meet NSF standards, this unit must be sealed to the floor.**

### Installation of glass shelves

1. Remove stainless steel shelf bracket assemblies by sliding key slots over shoulder bolts on inside edges of posts.
2. Plug light cords into receptacles.
3. Place 0.25" safety glass shelves on brackets.

### Installation of dry section front & side glass

1. Remove (2) acorn nuts on bottom side of shelf.
2. Remove top of stainless steel shelf by lifting shelf off subtop.
3. Place 0.25" thick side glass pieces into bottom channel and lower rear of stainless steel shelf.
4. Place 0.25" thick front glass piece into bottom channel and lower front of stainless steel shelf over top edge of glass.
5. Replace acorn nuts on bottom side of shelf.

## Display Case Glass Replacement

Delfield professionally packages the glass in the crate to minimize the risk of freight damage. However, during shipment glass damage can happen and breakage is not covered under warranty. If your Delfield unit arrives with broken glass in the top dry section, we recommend that you purchase replacement glass locally. The table to the right lists replacement sizes for the dry top section only.

Please call your Delfield service or sales representative if you have any questions on glass replacement.

### Plumbing

Self-contained models are standard with a condensate evaporator. If the evaporator fails, the unit's drain must have an outlet to an appropriate drainage area or container.



**Moisture collecting from improper drainage can create a slippery surface on the floor and a hazard to employees. It is the owner's responsibility to provide a container or outlet for drainage.**

### Electrical connection

Refer to the wattage data on page 2, the serial tag and your local code to be sure the unit is connected to the proper power source. A protected circuit of the correct voltage and amperage must run for connection of the line cord, or permanent connection to the unit.

Self-contained units have an ON/OFF switch located in the base of the unit. Simply turn the switch to ON to begin operation.



**The power switch must be turned OFF and the unit disconnected from the power source whenever performing service or maintenance functions.**

## Operation Information

On self-contained models, after turning the ON/OFF switch to ON, the unit's compressor will begin operating. Delfield display cases are designed to maintain an operation temperature of 36°F to 40°F at ambient room temperature of 75°F and relative humidity of 55%.

Do not load the storage area in a way that restricts the air flow. Overloading will result in a loss of temperature.

Continuous opening and closing of the doors will hamper the units ability to maintain operational temperature.

Shelves	Front	Sides
(Top) 34.0" x 15.84"	24.95" x 35.0"	Two Each Required: 24.57" tall; 19.38" at bottom 15.04" at top
(Center) 34.0" x 17.24"		
(Bottom) 32.50" x 15.43"		

\*\*\* All glass shelving is .25" thick safety glass.\*\*\*



## Maintenance

### Door Gasket Maintenance

Door gaskets require regular cleaning to prevent mold and mildew build up and also to retain the elasticity of the gasket. Gasket cleaning can be done with the use of warm soapy water. Avoid full strength cleaning products on gaskets as this can cause them to become brittle and crack. Never use sharp tools or knives to scrape or clean the gasket. Gaskets can be easily replaced and do not require the use of tools or an authorized service person. The gaskets are "Dart" style and can be pulled out of the groove in the door and new gaskets can be "pressed" back into place.

### Caster Maintenance

Wipe casters with a damp cloth monthly to prevent corrosion.



**The power switch must be turned to OFF and the unit disconnected from the power source whenever performing service, maintenance functions or cleaning the refrigerated area.**

### Refrigerators and Freezers

The interior and exterior can be cleaned using soap and warm water. If this isn't sufficient, try ammonia and water or a nonabrasive liquid cleaner. When cleaning the exterior, always rub with the "grain" of the stainless steel to avoid marring the finish. Do not use an abrasive cleaner because it will scratch the stainless steel and can damage the breaker strips and gaskets.

### Stainless Steel Care and Cleaning

To prevent discoloration or rust on stainless steel several important steps need to be taken. First, we need to understand the properties of stainless steel. Stainless steel contains 70- 80% iron, which will rust. It also contains 12-30% chromium, which forms an invisible passive film over the steel's surface, which acts as a shield against corrosion. As long as the protective layer is intact, the metal is still stainless. If the film is broken or contaminated, outside elements can begin to breakdown the steel and begin to form discoloration or rust. Proper cleaning of stainless steel requires soft cloths or plastic scouring pads.

### NEVER USE STEEL PADS, WIRE BRUSHES OR SCRAPERS!

Cleaning solutions need to be alkaline based or non-chloride cleaners. Any cleaner containing chlorides will damage the protective film of the stainless steel. Chlorides are also commonly found in hard water, salts, and household and industrial cleaners. If cleaners containing chlorides are used be sure to rinse repeatedly and dry thoroughly. Routine cleaning of stainless steel can be done with soap and water. Extreme stains or grease should be cleaned with a non-abrasive cleaner and plastic scrub pad. Always rub with the grain of the steel. There are stainless steel cleaners available which can restore and preserve the finish of the steels protective layer. Early signs of stainless steel breakdown are small pits and cracks. If this has begun, clean thoroughly and start to apply stainless steel cleaners in attempt to restore the passivity of the steel.



**Never use an acid based cleaning solution! Many food products have an acidic content, which can deteriorate the finish. Be sure to clean the stainless steel surfaces of ALL food products. Common items include, tomatoes, peppers and other vegetables.**

### Cleaning the Condenser Coil

In order to maintain proper refrigeration performance, the condenser fins must be cleaned of dust, dirt and grease regularly. It is recommended that this be done at least every three months. If conditions are such that the condenser is totally blocked in three months, the frequency of cleaning should be increased. Clean the condenser with a vacuum cleaner or stiff brush. If extremely dirty, a commercially available condenser cleaner may be required.

Failure to maintain a clean condenser coil can initially cause high temperatures and excessive run times. Continuous operation with a dirty or clogged condenser coil can result in compressor failure. Neglecting the condenser coil cleaning procedures will void any warranties associated with the compressor and cost to replace the compressor.



**Never use a high-pressure water wash for this cleaning procedure as water can damage the electrical components located near or at the condenser coil.**

### Doors/Hinges

Over time and with heavy use doors the hinges may become loose. If this happens tighten the screws that mount the hinge brackets to the frame of the unit. Loose or sagging doors can cause the hinges to pull out of the frame, which may damage both the doors and the hinges. In some cases this may require qualified service agents or maintenance personnel to perform repairs.



**Do not place hot pans on/against the blue ABS liner. Do not throw items into the storage area. Failure to follow these recommendations could result in damage to the interior of the cabinet or to the blower coil. Overloading the storage area, restricting the airflow, and continuous opening and closing of the doors and drawers will hamper the units ability to maintain operational temperature.**

### Preventing blower coil corrosion

To help prevent corrosion of the blower coil, store all acidic items, such as pickles and tomatoes, in sealable containers. Immediately wipe up all spills.



**Units with pans should be operated with pans in place. Operating the unit without all pans in place will lower efficiency and may damage the unit.**

Continuous opening and closing of the doors will hamper the unit's ability to maintain optimum refrigeration temperature. Top section is not intended for overnight storage. Product should be removed from pans. Pans can remain in unit while empty.

### Cleaning the condensate evaporator (remote models only)

The stainless steel condensate evaporator pan should be cleaned every six months. Use a vacuum cleaner or damp cloth to remove dust that may have accumulated. This will prevent corrosion of the stainless steel.

## Pressure Control Settings

The temperature is controlled by an adjustable pressure control located in the machine compartment. An adjustable control has the word **COLDER** near the knob, with an arrow to indicate the adjustment direction. These controls are field adjustable and do not require a service agent. If you have any questions, feel free to contact the Delfield Service Department.

The refrigeration system on self-contained models was adjusted at the factory to maintain between 36°F and 40°F. No adjustment should be necessary. If adjustment does become needed, however, the factory recommended settings are:

**Operating pressure:** 80 psi cut-in, 50 psi cut-out, 30 psi differential.

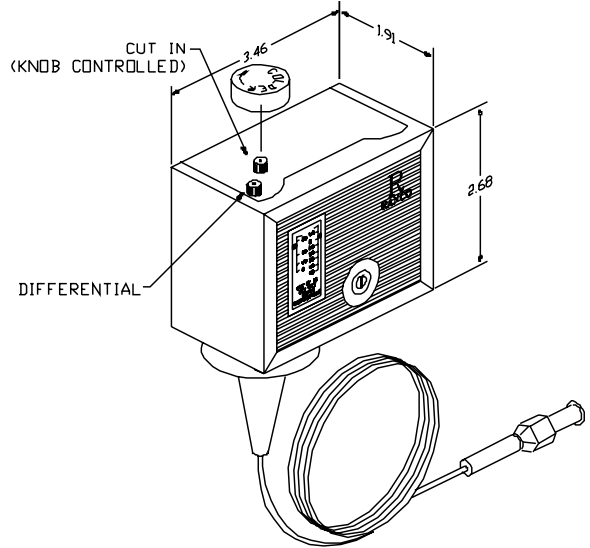

## Display Case Condensation And Temperature Adjustment

If your Delfield unit has excessive condensation on the refrigerated glass, the temperature should be adjusted to maintain 41° to minimize condensation.

There is a hanging thermometer in the refrigerated section. Please note that the adjustment needed is very small and it will take the case 24 hours to equilibrate after the adjustment is made.

## Wiring Diagram

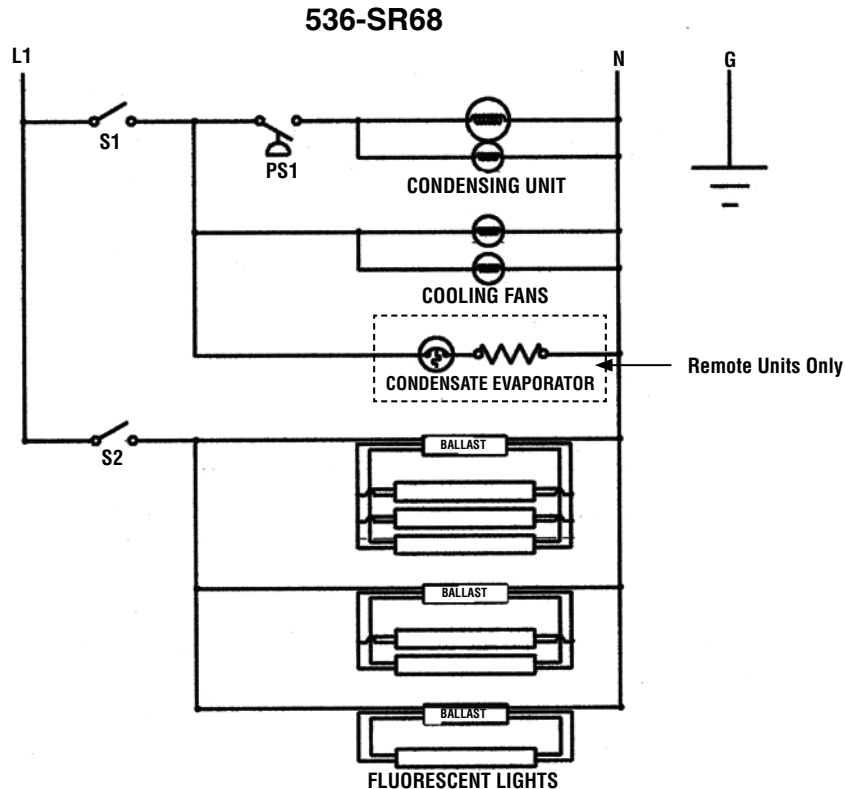

## Replacement Parts

Description	Part#
Adjustable foot leveler	3234696
Alum. light with 6" cord	2194523
Alum. light ext with 6" cord	2194526
Alum. light ext with 15" cord	2194524
Alum. light ext with 17" cord	2194525
Angled coil assy. cover	226-A12-Z0004
Box and ballast assy.	2194522
Button bumper	9291179
Compressor	3526752
Cord/plug assy.	2183347
Danfoss Condenser Kit <small>Includes control, display knobs, and probe</small>	2194753KT
Door catch magnet bracket	264-052-Z000D
Dry 24.95 x 35.00 glass front	3455355
Dry 24.75 x 19.38 glass side	3455357
Dry door plate mount LT	264-AYK-Z000E
Dry door plate mount RT	264-AYK-Z000F
Evaporator coil	3510086
Evaporator fan motor	2162691
Expansion valve	3516273
Fan motor blower coil bracket	031-264-0000
Filter dryer	3516101
Glass shelf 15.43 x 32.50	3544342
Glass shelf - bottom dry	3455341
Glass shelf - top dry	3455340
Lexan fan blade	3516172
Lexan fan guard	3516173
Louver access front s/s	311-411-Z0005
Louvered panel access	312-411-Z0004
Magnetic snap in catch	3234156
*Pike door and frame assy.	3234299
*Pike door dry hinged set	3234300
Plastic drain	3234242
Rocker switch	2190154
Screw #8	9321137

\*Special order item. Allow for longer delivery time.

## Standard Labor Guidelines To Repair Or Replace Parts On Delfield Equipment

Advice and recommendations given by Delfield Service Technicians do not constitute or guarantee any special coverage.

- A maximum of 1-hour is allowed to **diagnose a defective component**.
- A maximum of 1-hour is allowed for **retrieval of parts** not in stock.
- A maximum **travel distance** of 100 miles round trip and 2-hours will be reimbursed.
- Overtime, installation/start-up, normal control adjustments, general maintenance, glass breakage, freight damage, and/or correcting and end-user installation error will not be reimbursed under warranty unless pre-approved with a **Service Work Authorization** from Delfield. You must submit the number with the service claim.

### LABOR OF 1-HOUR IS ALLOWED TO REPLACE:

- Circulating Fan Motor and Blade
- Compressor Start Components and Overload Protector
- Condensate Element
- Door Hinges, Locks, and Gaskets
- Evaporator/Condenser Fan Motor and Blade

### LABOR OF 2 HOURS TO REPLACE:

- Heating Element
- Locate/Repair Leak
- Pressure Control

### LABOR OF 3 HOURS TO REPLACE:

- Condenser or Evaporator Coil
- Expansion Valve

### LABOR OF 4 HOURS TO REPLACE:

- Compressor

This includes recovery of refrigerant and leak check.

\$55.00 maximum reimbursement for refrigerant recovery (includes recovery machine, pump, torch, oil, flux, minor fittings, solder, brazing rod, nitrogen, or similar fees.)

### REFRIGERANTS

- R404A A maximum of \$15.00/lb. or &1.00/oz. will be reimbursed.



## Standard One Year Warranty (One year parts, 90 days labor.)

The Delfield Company ("Delfield") warrants to the Original Purchaser of the Delfield product (herein called the "Unit") that such Unit, and all parts thereof, will be free from defects in material and workmanship under normal use and service for a period of one (1) year from the date of shipment of the Unit to the Original Purchaser **or, if the Original Purchaser returns the warranty card completely filled out including the date of installation within thirty (30) days of receipt of the Unit, one (1) year from the date of installation.** During this one year warranty period, Delfield will repair or replace any defective part or portion thereof returned to Delfield by the Original Purchaser which Delfield determines was defective due to faulty material or workmanship. The Original purchaser will pay all labor, crating, freight and related costs incurred in the removal of the Unit of defective component and shipment to Delfield, except that during a period of either ninety (90) days from the date of shipment of the Unit to the Original Purchaser or, if the Original Purchaser returns the warranty card completely filled out including the date of installation within thirty (30) days of receipt of the Unit, ninety (90) days from the date of installation Delfield will pay all related labor costs. Delfield will pay the return costs if the Unit or part thereof was defective.

The term "Original Purchaser" as used herein means that person, firm, association, or corporation for whom the Unit was originally installed.

This warranty does not apply to any Unit or part thereof that has been subjected to misuse, neglect, alteration, or accident, such as accidental damage to the exterior finish, operated contrary to the recommendations specified by Delfield; or repaired or altered by anyone other than Delfield in any way so as to, in Delfield's sole judgement, affect its quality or efficiency. This warranty does not apply to any Unit that has been moved from the location where it was originally installed. This warranty also does not cover the refrigerator drier or the light bulbs used in the Unit. **The warranty is subject to the user's normal maintenance and care responsibility as set forth in the Service and Installation Manual, such as cleaning the condenser coil, and is in lieu of all other obligations of Delfield. Delfield neither assumes, nor authorizes any other person to assume for Delfield, any other liability in connection with Delfield's products.**

Removal or defacement of the original Serial Number or Model Number from any Unit shall be deemed to release Delfield from all obligations hereunder or any other obligations, express or implied.

Parts furnished by suppliers to Delfield are guaranteed by Delfield only to the extent of the original manufacturer's express warranty to Delfield. Failure of the Original Purchaser to receive such manufacturer's express warranty to Delfield. Failure of the Original Purchaser to receive such manufacturer's warranty shall in no way create any warranty, expressed or implied, or any other obligation or liability on Delfield's part in respect thereof.

**IF THE CUSTOMER IS USING A PART THAT RESULTS IN A VOIDED WARRANTY AND A DELFIELD AUTHORIZED REPRESENTATIVE TRAVELS TO THE INSTALLATION ADDRESS TO PERFORM WARRANTY SERVICE, THE SERVICE REPRESENTATIVE WILL ADVISE CUSTOMER THE WARRANTY IS VOID. SUCH SERVICE CALLS WILL BE BILLED TO CUSTOMER AT THE AUTHORIZED SERVICE CENTER'S THEN APPLICABLE TIME AND MATERIALS RATES. CONSIDER: CUSTOMER MAY INITIATE A SERVICE AGREEMENT WITHOUT PARTS COVERAGE.**

If shipment of a replacement part is requested prior to the arrival in the Delfield factory of the part claimed to be defective, the Original Purchaser must accept delivery of the replacement part of a C.O.D. basis, with credit being issued after the part has been received and inspected at Delfield's plant and determined by Delfield to be within this warranty.

Under no condition does this warranty give the Original Purchaser the right to replace the defective Unit with a complete Unit of the same manufacturer or of another make. Unless authorized by Delfield in writing, this warranty does not permit the replacement of any part, including the motor-compressor, to be made with the part of another make or manufacturer.

No claims can be made under this warranty for spoilage of any products for any reason, including system failure.

The installation contractor shall be responsible for building access, entrance and field conditions to insure sufficient clearance to allow any hood(s), vent(s), or Unit(s) if necessary, to be brought into the building. Delfield will not be responsible for structural changes or damages incurred during installation of the Unit or any exhaust system.

Delfield shall not be liable in any manner for any default or delay in performance hereunder caused by or resulting from any contingency beyond Delfield's control, including, but not limited to, war, governmental restrictions or restraints, strike, lockouts, injunctions, fire, flood, acts of nature, short or reduced supply of raw materials, or discontinuance of the parts by the original part manufacturer.

**Except as provided in any Additional Four Year Protection Plan, if applicable, and the Service Labor Contract, if applicable, the foregoing is exclusive and in lieu of all other warranties, whether written or oral, express or implied. This warranty supersedes and excludes any prior oral or written representations or warranties. Delfield expressly disclaims any implied warranties of merchantability, fitness for a particular purpose of compliance with any law, treaty, rule or regulation relating to the discharge of substances into the environment. The sole and exclusive remedies of any person relating to the Unit, and the full liability of Delfield for any breach of this warranty, will be as provided in this warranty.**

Other than this Delfield Standard One Year Limited Warranty, any applicable Delfield Additional Four Year Protection Plan or applicable Delfield Service Labor Contract, the Original Purchaser agrees and acknowledges that no other warranties are offered or provided in connection with or for the unit or any other part thereof.

In no event will Delfield be liable for special, incidental or consequential damages, or for damages in the nature of penalties.

**IF DURING THE WARRANTY PERIOD, CUSTOMER USES A PART FOR THIS DELFIELD EQUIPMENT OTHER THAN AN UNMODIFIED NEW OR RECYCLED PART PURCHASED DIRECTLY FROM DELFIELD OR ANY OF ITS AUTHORIZED SERVICE CENTERS AND/OR THE PART BEING USED IS MODIFIED FROM ITS ORIGINAL CONFIGURATION, THIS WARRANTY WILL BE VOID. FURTHER, DELFIELD AND ITS AFFILIATES WILL NOT BE LIABLE FOR ANY CLAIMS DAMAGES OR EXPENSES INCURRED BY THE CUSTOMER WHICH ARISE DIRECTLY OR INDIRECTLY, IN WHOLE OR IN PART, DUE TO THE INSTALLATION OF ANY MODIFIED PART AND/OR PART RECEIVED FROM AN UNAUTHORIZED SERVICE CENTER. If the warranty becomes void, Customer may purchase from Delfield, if available, a Service Agreement or service at the then current time and materials rate.**

For more information on Delfield warranty's log on and check out the service section of our web site at [www.delfield.com](http://www.delfield.com).



**Additional Four Year Protection Plan** (for Motor-Compressor only)

Delfield Model#	Serial #	Installation Date

Replacement of a defective Motor-Compressor is limited to one (1) Motor-Compressor by us during the four (4) year period. Delfield shall replace the Motor-Compressor at no charge.

In addition to the Standard One Year Warranty on the Motor-Compressor contained in the above listed Delfield product (the "Unit"), The Delfield Company ("Delfield") also agrees to repair, or exchange with similar or interchangeable parts in design and capacity at Delfield's option, the defective Motor-Compressor contained in the Unit (the "Motor-Compressor"), or any part thereof, for the Original Purchaser only, at any time during the four (4) years following the initial one (1) year period commencing on the date of installation for the Original Purchaser. **Failure of the Original Purchaser to register the registration card containing the Original Purchasers name, address, date of installation, model number and serial number of the Unit containing the Motor-Compressor within 30 days from the date of installation shall void this warranty.** This additional warranty is only available if the Motor-Compressor is inoperative due to defects in material or factory workmanship, as determined by Delfield in its sole judgement and discretion. The Original Purchaser shall be responsible for returning the defective Motor-Compressor to Delfield prepaid, F.O.B. at the address shown on the back cover of this manual.

This warranty does not give the Original Purchaser of the Motor-Compressor the right to purchase a complete replacement Motor-Compressor of the same make or of another make. It further does not permit the replacement to be made with a Motor-Compressor of another kind unless authorized by Delfield. In the event Delfield authorizes the Original Purchaser to purchase a replacement Motor-Compressor locally, only the wholesale cost of the Motor-Compressor is refundable.

Expressly excluded from this warranty are damages resulting from spoilage of goods.

The term "Original Purchaser" as used herein means that person, firm, association, or corporation for whom the Unit was originally installed.

**Except as provided in any applicable Standard One Year Limited Warranty or applicable Service Labor Contract, the foregoing is exclusive and in lieu of all other warranties, whether written or oral, express or implied. This Warranty supersedes and excludes any prior oral or written representations or warranties. Delfield expressly disclaims any implied warranties of merchantability, fitness for a particular purpose or compliance with any law, treaty, rule or regulation relating to the Motor-Compressor, and the full liability of Delfield for any breach of this warranty, will be as provided in this warranty.**

The term "Motor-Compressor" as used herein does not include unit base, air or water cooled condenser, receiver, electrical accessories such as relay, capacitors, refrigerant controls, or condenser fan/motor assembly. This warranty does not cover labor charges incidental to the replacement of parts. This warranty further does not include any equipment to which said condensing unit is connected, such as cooling coils, temperature controls or refrigerant metering devices. This warranty shall be void if the Motor-Compressor, in Delfield's sole judgement, has been subjected to misuse, neglect, alteration or accident, operated contrary to the recommendations specified by the Unit manufacturer, repaired or altered by anyone other than Delfield in any way so as, in Delfield's sole judgment, to affect its quality or efficiency or if the serial number has been altered, defaced or removed. This Warranty does not apply to a Motor-Compressor in any Unit that has been moved from the location where it was originally installed. The addition of methyl chloride to the condensing unit or refrigeration system shall void this warranty.

Other than any applicable Delfield Standard One year Limited Warranty, this Delfield Additional Four Year Protection Plan and any applicable Delfield Service Labor Contract, the Original Purchaser agrees and acknowledges that no other warranties are offered or provided in connection with or for the Motor-Compressor or any part thereof.

In no event will Delfield be liable for special, incidental or consequential damages, or for damages in the nature of penalties.

**General Conditions**

Delfield shall not be liable in any manner for any default or delay in performance hereunder caused by or resulting from any contingency beyond Delfield's control, including, but not limited to, war, governmental restrictions or restraints, strike, lockouts, injunctions, fire, flood, acts of nature, short or reduced supply of raw materials, or discontinuance of any part or the Motor-Compressor by the unit manufacturer.



**Notes:**

**Notes:**



***Mt. Pleasant, MI***



***Covington, TN***

***Thank you for choosing Delfield!***

Help is a phone call away. Help our team of professional, courteous customer service reps by having your model number and serial number available at the time of your call (800) 733-8829.

Model: \_\_\_\_\_ S/N: \_\_\_\_\_

Installation Date: \_\_\_\_\_



**For a list of Delfield's authorized parts depots,  
visit our website at [www.delfield.com](http://www.delfield.com).**

