

# 6000XL & 6100XL Series Reach Ins

## Parts List

### Contents

Refrigeration Package Diagram .....	2
Refrigerator - 1 Section & 3 Section Left Package .....	3
Refrigerator - 2 Section & 3 Section Right Package .....	3
Freezer- 1 Section & 3 Section Left Package.....	4
Freezer- 2 Section & 3 Section Right Package.....	4
Miscellaneous Replacement Parts.....	5
Stainless Steel Door Replacement Parts .....	5
Glass Door Replacement Parts .....	5

# Refrigeration Package Diagram

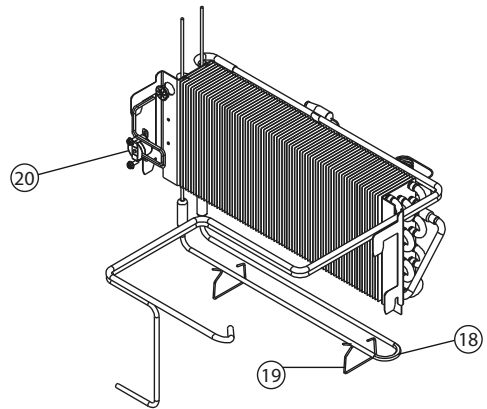
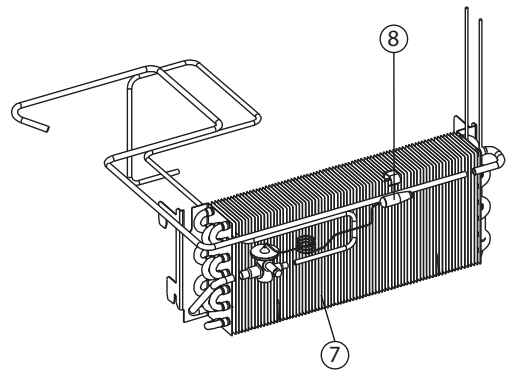
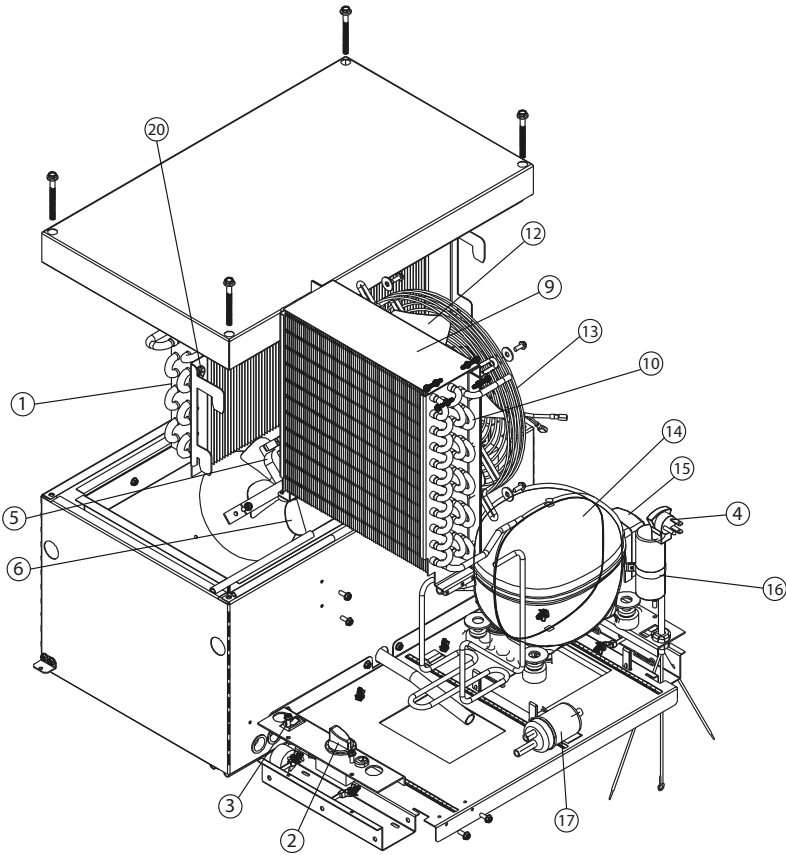
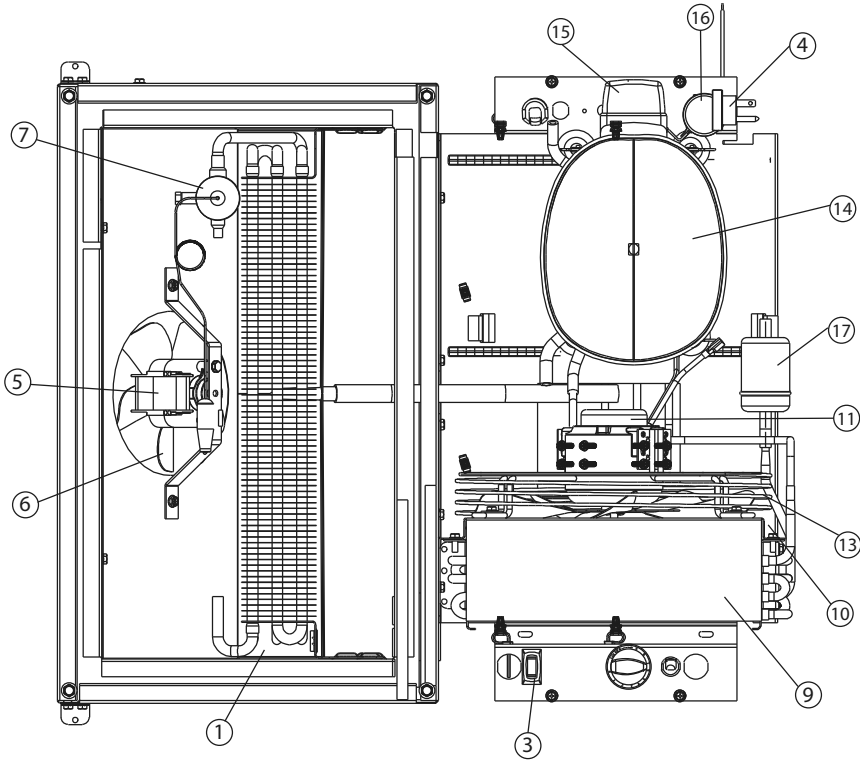

## Refrigerator - 1 Section & 3 Section Left Package

Key	Description	Part Number	220V/50Hz Part Number
1	Coil, evaporator	3516437	
2	Temperature Control	2194811KT	2194988KT
3	Switch, energy saver	2190154	
4	Cord, power	2184181	
5	Motor, fan, evaporator	2162715	2162719
6	Fan blade, evaporator	3517390	
7	Valve, refrigerant, TXV	3516429	
8	Clip, TXV bulb mounting	3516595	
9	Coil, condenser	3516427	
10	Shroud, condenser fan	127-C33-0036	
11	Motor, fan, condenser, 9W	2162717	2192720
12	Fan blade, condenser	3516432	
13	Guard, condenser fan	2160019	
14	Compressor Compressor, 50Hz - NL7CUX	3526999	3527013
15	Relay & overload, compressor 50Hz Relay and overload, Danfoss p/n	3516444	117U6002
16	Capacitor, compressor start, 280MFD 50Hz Capacitor, start, 80MFD, Danfoss p/n	2194787	117U5015
17	Filter-drier, refrigerant	3516322	
	Condensate pan	1702795	
	Solenoid valve, used on remote units	3516041	

## Refrigerator - 2 Section & 3 Section Right Package

Key	Description	Part Number	220V/50Hz Part Number
1	Coil, evaporator	3516437	
2	Temperature Control	2194811KT	2194988KT
3	Switch, energy saver	2190154	
4	Cord, power	2184181	
5	Motor, fan, evaporator	2162715	2192719
6	Fan blade, evaporator	3517390	
7	Valve, refrigerant, TXV	3516429	
8	Clip, TXV bulb mounting	3516595	
9	Coil, condenser	3516427	
10	Shroud, condenser fan	127-C33-0030	
11	Motor, fan, condenser, 16W	2162716	2162721
12	Fan blade, condenser	3516433	
13	Guard, condenser fan	2160019	
14	Compressor, Kit Compressor, 50Hz - SC15CLX.2 danfoss	3527000	3527012
15	Relay & overload, compressor 50Hz Relay and overload, Danfoss p/n	3516438	117U6003
16	Capacitor, compressor start, 320MFD 50Hz Capacitor, start, 80MFD, Danfoss p/n	2194788	117U5015
17	Filter-drier, refrigerant	3516322	
	Condensate pan	1702795	
	Solenoid valve, used on remote units	3516041	

## Freezer- 1 Section & 3 Section Left Package

Key	Description	Part Number	220V/50Hz Part Number
1	Coil, evaporator	3516436	
2	Control, ETC1, Kit	2194812KT	2194964KT
3	Switch, SPDT, energy saver	2194959	
4	Cord, power	2184181	2194183
5	Motor, fan, evaporator	2162715	2162719
6	Fan blade, evaporator	3517390	
7	Valve, refrigerant, TXV	3516588	
8	Clip, TXV bulb mounting	3516595	
9	Coil, condenser	3516427	
10	Shroud, condenser fan	127-C33-0036	
11	Motor, fan, condenser, 9W	2162717	2162720
12	Fan blade, condenser	3516432	
13	Guard, condenser fan	2160019	
14	Compressor Compressor, 50 Hz - NL8.4CLX Danfoss	3527001	3527011
15	Relay & overload, compressor 50Hz Relay and overload, Danfoss	3516441	117U6019
16	Capacitor, compressor start, 240MFD 50Hz Capacitor, start, 80MFD, Danfoss	2194789	117U5017
17	Filter-drier, refrigerant	3516322	
18	Heater, defrost	2194785	2194967
19	Clip, defrost heater mounting	9321629	
20	Switch, defrost safety, high limit	2194953	
	Condensate pan	1702795	
	Solenoid valve, used on remote units	3516041	

## Freezer- 2 Section & 3 Section Right Package

Key	Description	Part Number	220V/50Hz Part Number
1	Coil, evaporator	3516436	
2	Control, ETC1, Kit	2194812KT	2194964KT
3	Switch, SPDT, energy saver Switch, SPST, ON/OFF	2194959 2190154	
4	Cord, power	2184231	2194183
5	Motor, fan, evaporator	2162715	2162719
6	Fan blade, evaporator	3517390	
7	Valve, refrigerant, TXV	3516588	
8	Clip, TXV bulb mounting	3516595	
9	Coil, condenser	3516427	
10	Shroud, condenser fan	127-C33-0030	
11	Motor, fan, condenser, 16W	2162716	2162721
12	Fan blade, condenser	3516433	
13	Guard, condenser fan	2160019	
14	Compressor, Kit Compressor, 50Hz - Sc18CLX.2, danfoss	3527002	3527010
15	Relay and capacitor, compressor start, 125MFD 50Hz Relay, Danfoss	3516468	117U6013 117U5012
16	50Hz Capacitor, start, 125MFD, Danfoss		
17	Filter-drier, refrigerant	3516322	
18	Heater, defrost	2194785	2194967
19	Clip, defrost heater mounting	9321629	
20	Switch, defrost safety, high limit	2194953	
	Condensate pan	1702795	
	Solenoid valve, used on remote units	3516041	

## Miscellaneous Replacement Parts

Description	Part Number
Cable	2194791
Casters, rigid, One section only	3235514
Casters, swivel, with brake	3234779
Casters, swivel, without brake, Two & Three section	3234778
Display	2194792
Door lock	3239590
Legs	3234791
Shelf, One Section, Three Section	3978270
Shelf LH, Two Section, Three Section	3978277
Shelf RH, Two Section, Three Section	3978278
Switch, rocker, door, SPDT-D8	5066440
Vacuum breaker	3516204A

## Stainless Steel Door Replacement Parts

Description	Part Number
Bulb, incandescent, 40W	2194005
Bulb, socket	2194145
Full Door, S/S, hinged left, edge mount hinges	000-AB9-013K
Full Door, S/S, hinged right, edge mount hinges	000-AB9-013J
Half Door, S/S, bottom left, edge mount hinges	000-AB9-013P
Half Door, S/S, bottom right, edge mount hinges	000-AB9-013R
Half Door, S/S, top left, edge mount hinges	000-AB9-013M
Half Door, S/S, top right, edge mount hinges	000-AB9-013N
Hinge, 1-5/16" offset with adjustable housing	3234617KT
Gasket, full door, S/S	1702796
Gasket, half door, S/S	1702797

## Glass Door Replacement Parts

Description	Part Number
Ballast	2198540
Bulb, fluorescent, 18" coated, F15T8	2194290
Full door, glass, hinged left, edge mount hinges	000-AB9-013U
Full door, glass, hinged right, edge mount hinges	000-AB9-013T
Half door, glass, bottom left, edge mount hinges	000-AB9-013Y
Half door, glass, bottom right, edge mount hinges	000-AB9-013Z
Half door, glass, top left, edge mount hinges	000-AB9-013W
Half door, glass, top right, edge mount hinges	000-AB9-013X
Hinge, 1-5/16" Offset with adjustable housing	3234617KT
Gasket, full door, glass	1701901
Gasket, half door, glass	1701902
Lampholder	2194289

