

ASM Series

Original Instructions Service Manual

English

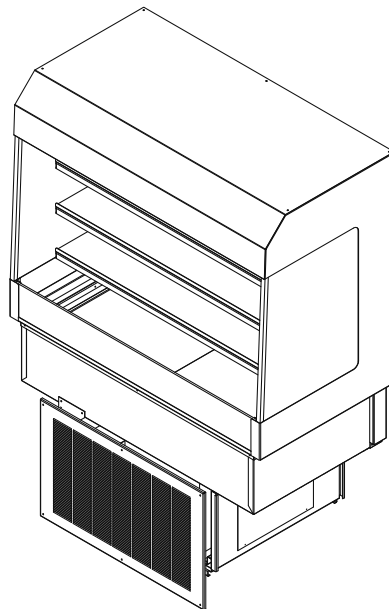

Safety Notices

⚠ Warning

Read this manual thoroughly before operating, installing or performing maintenance on the equipment. Failure to follow instructions in this manual can cause property damage, injury or death.

⚠ DANGER

Do not lift the condensing unit by the refrigerant tubing or other components. These features will not support the condensing unit weight. Injury and unit damage may occur!

⚠ DANGER

Do not install or operate equipment that has been misused, abused, neglected, damaged, or altered/modified from that of original manufactured specifications.

⚠ DANGER

All utility connections and fixtures must be maintained in accordance with Local and national codes.

⚠ DANGER

Keep power cord AWAY from HEATED surfaces. DO NOT immerse power cord or plug in water. DO NOT let power cord hang over edge of table or counter.

⚠ Warning

Authorized Service Representatives are obligated to follow industry standard safety procedures, including, but not limited to, local/national regulations for disconnection / lock out / tag out procedures for all utilities including electric, gas, water and steam.

⚠ Warning

This appliance is not intended for use by persons (including children) with reduced physical, sensory or mental capabilities, or lack of experience and knowledge, unless they have been given supervision concerning use of the appliance by a person responsible for their safety. Do not allow children to play with this appliance.

⚠ Warning

Do not store or use gasoline or other flammable vapors or liquids in the vicinity of this or any other appliance. Never use flammable oil soaked cloths or combustible cleaning solutions, for cleaning.

⚠ Warning

This product contains chemicals known to the State of California to cause cancer and/or birth defects or other reproductive harm. Operation, installation, and servicing of this product could expose you to airborne particles of glasswool or ceramic fibers, crystalline silica, and/or carbon monoxide. Inhalation of airborne particles of glasswool or ceramic fibers is known to the State of California to cause cancer. Inhalation of carbon monoxide is known to the State of California to cause birth defects or other reproductive harm.

⚠ Warning

Do not use electrical appliances or accessories other than those supplied by the manufacturer.

⚠ Warning

Use caution when handling metal surface edges of all equipment.

⚠ Warning

DO NOT touch refrigeration lines inside units; some may exceed temperatures of 200°F (93.3°C).

Note

Proper installation, care and maintenance are essential for maximum performance and trouble-free operation of your equipment. Visit our website www.mtwkitchencare.com for manual updates, translations, or contact information for service agents in your area.

Table of Contents

Section 1 General Information

Model Numbers	5
Serial Number Location	5
Warranty Information	5
Regulatory Certifications	5
Dimensioned Drawings	6

Section 2 Installation

Location	7
Weight of Equipment	7
Clearance Requirements.....	7
Dimensions	8
Electrical Service	8
Voltage	8
Fuse/Circuit Breaker	8
Ground Fault Circuit Interrupter	8
Rated Amperages, Horsepower, Voltage & Power Cord Chart.....	9
Installation Instructions	9
Louvers.....	10
Plumbing.....	11
Leveling.....	11
Shelf Adjustments	11
Sliding Door Removal And Reinstall.....	12

Section 3 Operation

Operation.....	13
Temperature Control Settings.....	14
Reading The Temperature At Defrost Sensor	14
Change Coil Temperature.....	14
Change Other Parameter Values.....	14

Section 4 Maintenance

Cleaning and Sanitizing Procedures.....	15
General.....	15
Interior Cleaning.....	15
Exterior Cleaning.....	16
Plexiglas, Including Baffles.....	16
Sliding Doors.....	16
Drain.....	16
Cleaning the Condenser Coil	16

**Section 5
Controls**

Control Parameter Factory Settings 17

**Section 6
Diagrams**

ASM-36 & ASM-48 19
ASM-60 20
Remote Models ASM-36R, ASM-48R, ASM-60R* 21

Section 1

General Information

Model Numbers

This manual covers standard units only.

NOTE: For custom units, consult Manitowoc KitchenCare at 1-844-724-CARE.

Drop-In Air Screen Merchandisers
ASM-36
ASM-48

Serial Number Location

The serial number on all self-contained Drop-In Air Screen Merchandisers is located on the mechanical section wall.

Always have the serial number of your unit available when calling for parts or service.



Warranty Information

- Register your product for warranty.
- Verify warranty information.
- View and download a copy of your warranty.

At www.delfield.com/warranty

Regulatory Certifications

All models are certified by:

-  National Sanitation Foundation (NSF)
-  Underwriters Laboratories (UL)
-  Underwriters Laboratories of Canada (cUL)

Dimensioned Drawings

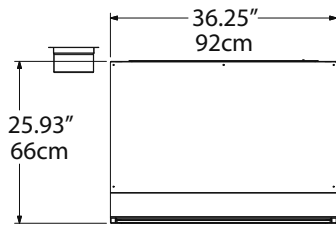

Plan View, ASM-36

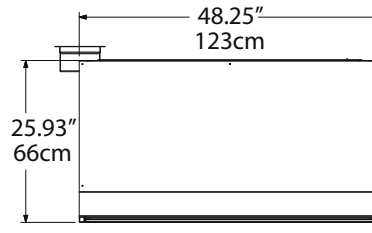

Plan View, ASM-48

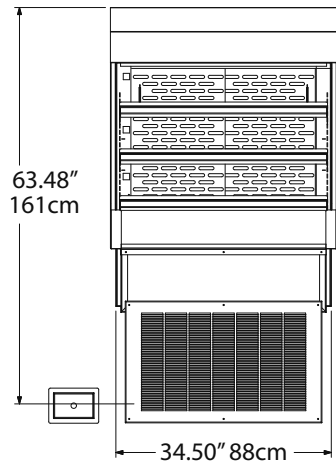

Elevation View, ASM-36

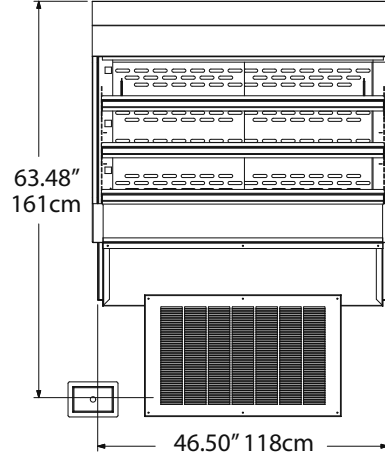

Elevation View, ASM-48

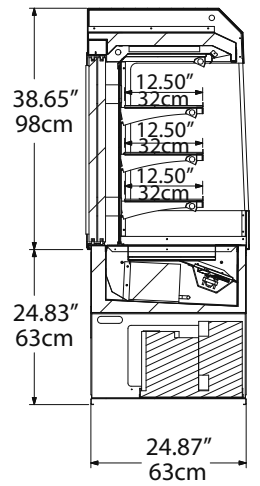

Left Section View,
ASM-36, ASM-48

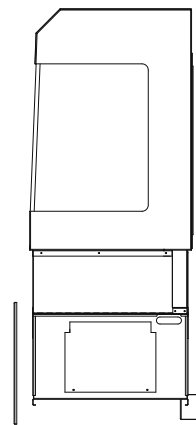

Right Side View,
ASM-36, ASM-48

Section 2 Installation

⚠ DANGER

Installation must comply with all applicable fire and health codes in your jurisdiction.

⚠ DANGER

Use appropriate safety equipment during installation and servicing.

⚠ Warning

Do not damage the refrigeration circuit when installing, maintaining or servicing the unit.

Location

⚠ Warning

This equipment must be positioned so that the plug is accessible unless other means for disconnection from the power supply (e.g., circuit breaker or disconnect switch) is provided.

⚠ Warning

Adequate means must be provided to limit the movement of this appliance without depending on or transmitting stress to the electrical conduit or gas lines.

⚠ Warning

To avoid instability the installation area must be capable of supporting the combined weight of the equipment and product. Additionally the equipment must be level side to side and front to back.

⚠ Warning

This equipment is intended for indoor use only. Do not install or operate this equipment in outdoor areas.

The location selected for the equipment must meet the following criteria. If any of these criteria are not met, select another location.

- Units are intended for indoor use only.
- Unit is designed to maintain 36°F - 40°F at 80°F ambient room temperature (2°C - 4°C at 27°C) in 55% or lower relative humidity.
- The location **MUST** be level, stable and capable of supporting the weight of the equipment.
- The location **MUST** be free from and clear of combustible materials.
- Equipment **MUST** be level both front to back and side to side.
- Position the equipment so it will not tip or slide.
- Proper air supply for ventilation is **REQUIRED AND CRITICAL** for safe and efficient operation. Refer to Clearance Requirements chart on page 7.
- Do not obstruct the flow of ventilation air. Make sure the air vents of the equipment are not blocked.
- Do not install the equipment directly over a drain. Steam rising up out of the drain will adversely affect operation, air circulation, and damage electrical / electronic components.

Weight of Equipment

Model	Weight
ASM-36	425lbs (193kg)
ASM-48	500lbs (227kg)

Clearance Requirements

⚠ DANGER

Minimum clearance requirements are the same for noncombustible locations as for combustible locations. The flooring under the appliance must be made of a noncombustible material.

⚠ DANGER

Risk of fire/shock. All minimum clearances must be maintained. Do not obstruct vents or openings.

Sides

1" (2.5cm)

- Keep the vents clean and free of obstruction.

Dimensions

Model	Length	Depth	Height
ASM-36	36.25" (92cm)	25.93" (66cm)	63.48" (161cm)
ASM-48	48.25" (123cm)	25.93" (66cm)	63.48" (161cm)

Model	Display Storage
ASM-36	8.2ft ³
ASM-48	11.3ft ³

These units are installed by placing them into the counter from above. The counter cutout sizes are as follows.

Model	Counter Cutout Dimensions
ASM-36	35.13" x 25.50" (89cm x 65cm)
ASM-48	47.13" x 25.50" (120cm x 65cm)

Model	Louver Cutout Dimensions
ASM-36	28.00" x 17.00" (71cm x 42cm)
ASM-48	28.00" x 17.00" (71cm x 42cm)

Model	Control Cutout Dimensions
ASM-36	6.75" x 4.37" (17cm x 11cm)
ASM-48	6.75" x 4.37" (17cm x 11cm)

Electrical Service

⚠ DANGER

Check all wiring connections, including factory terminals, before operation. Connections can become loose during shipment and installation.

⚠ Warning

This appliance must be grounded and all field wiring must conform to all applicable local and national codes. Refer to rating plate for proper voltage. It is the responsibility of the end user to provide the disconnect means to satisfy the authority having jurisdiction.

VOLTAGE

All electrical work, including wire routing and grounding, must conform to local, state and national electrical codes.

The following precautions must be observed:

- The equipment must be grounded.
- A separate fuse/circuit breaker must be provided for each unit.
- Check all green ground screws, cables and wire connections to verify they are tight before start-up.

FUSE/CIRCUIT BREAKER

A separate fuse/circuit breaker must be provided for each unit.

GROUND FAULT CIRCUIT INTERRUPTER

Ground Fault Circuit Interrupter (GFCI/GFI) protection is a system that shuts down the electric circuit (opens it) when it senses an unexpected loss of power, presumably to ground. Manitowoc does not recommend the use of GFCI/GFI circuit protection to energize our equipment. If code requires the use of a GFCI/GFI then you must follow the local code. The circuit must be dedicated, sized properly and there must be a panel GFCI/GFI breaker. We do not recommend the use of GFCI/GFI outlets to energize our equipment as they are known for more intermittent nuisance trips than panel breakers.

RATED AMPERAGES, HORSEPOWER, VOLTAGE & POWER CORD CHART

Model	ASM-36	ASM-48
Amps	10.8	12.8
HP	1/2	3/4
Voltage, Cycle, Phase	115V, 60Hz, 1Ph	115V, 60Hz, 1Ph
NEMA Plug	5-15P	5-20P
Cord Length	9ft (2.7m)	9ft (2.7m)

Refrigeration

Model	ASM-36	ASM-48
R404A Charge	32oz	48oz
Cabinet Load BTU/Hour	4750	6250
System Capacity BTU/Hour	5278	6944

Installation Instructions

1. Remove the stainless steel pans in the bottom of the unit.
2. Remove the stainless steel pan clip rail below the door track.
3. Bolt in the lifting plates using the bolts located inside the tank that are installed in the lifting braces.
4. Slide two 1" steel pipes into the lifting plate holes. Place forklift forks under the pipes and clamp the forks and pipes in position.



Lifting Plates and 1" Steel Pipes

5. Raise the unit high enough with the forklift to roll the base under the unit into position. Lower the ASM unit into the base using care to clear all of the flanges and screw heads.

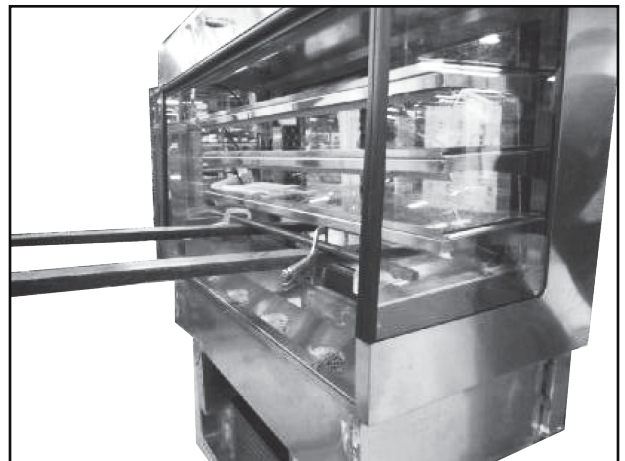

Lifted ASM

6. Remove the bolts and remove the lifting plates. Install plastic plugs in the bolt holes.
7. Install the stainless steel pan clip rail below the door track.
8. Install the stainless steel pans in the bottom on the unit making sure the turn down is engaged in the slot below the door track.
9. Install the sneeze guard glass in the clips and attach the end clip with two stainless steel self tapping screws.
10. Use gray silicone to finish the joint between the drop in unit and the top of the base.

LOUVERS

Two louvers are provided with each unit and must be installed in 28.00" x 17.00" (71 cm x 42cm) cutouts.

Cut-outs are to begin at 10.00" (25cm) from the counter-top.

For the most efficient refrigeration, be sure to provide good air circulation inside and out. Don't pack the merchandiser so full that air cannot circulate. Avoid hot corners and locations near stoves and ovens.

Air movement in the room will adversely effect ASM refrigeration. Do not place the model near doors or air vents.

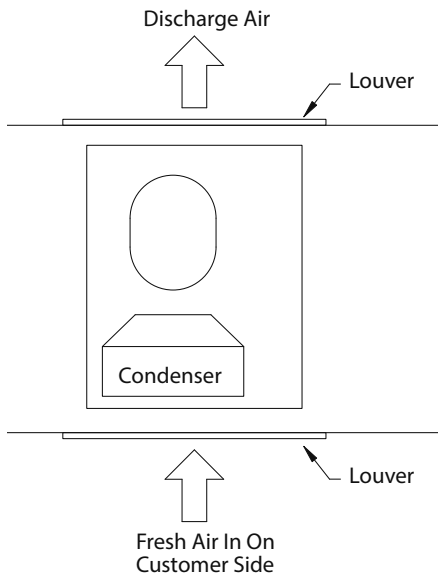

Air Flow Detail

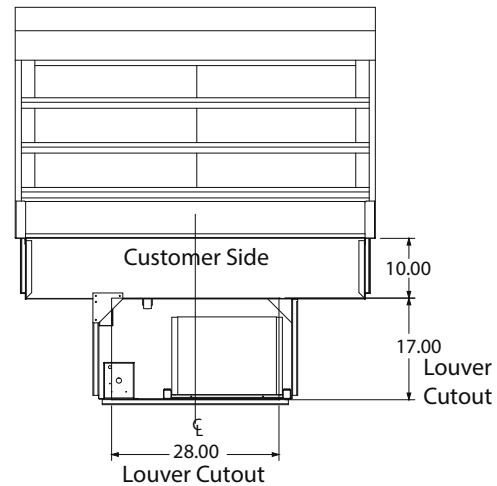

Customer Side Louver Cutout Dimensions

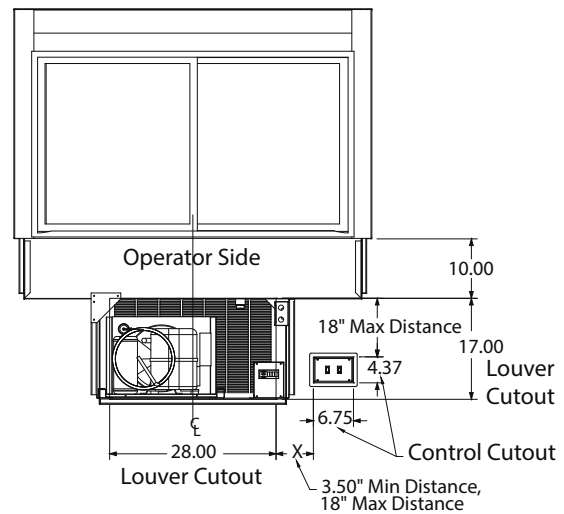

Operator Side Louver & Control Cutout Dimensions

Plumbing

Standard models will have a 1/2" drain which will need to be run to an appropriate floor drain. The drain will be stubbed inside the machine compartment.

⚠ Warning

Moisture collecting from improper drainage can create a slippery surface on the floor and a hazard to employees. It is the owner's responsibility to provide a container or outlet for drainage.

Leveling

After the cabinet has been placed in the desired location, cabinets with legs must be leveled. Level units from front to back and from side to side. Leveling will insure proper door operation and removal of condensate.

Shelf Adjustments

Display cases come with three tempered glass shelves that are adjustable in 1" increments.

Shelves can be slanted at three different angles. Remove the glass and unplug the light before adjusting the shelves.

Maximum weight for 36" (91cm) shelves is 25 lbs (11kg).

Maximum weight for 48" (122cm) shelves is 35 lbs (16kg).

⚠ Caution

Overloading shelves can damage equipment or cause bodily injury.

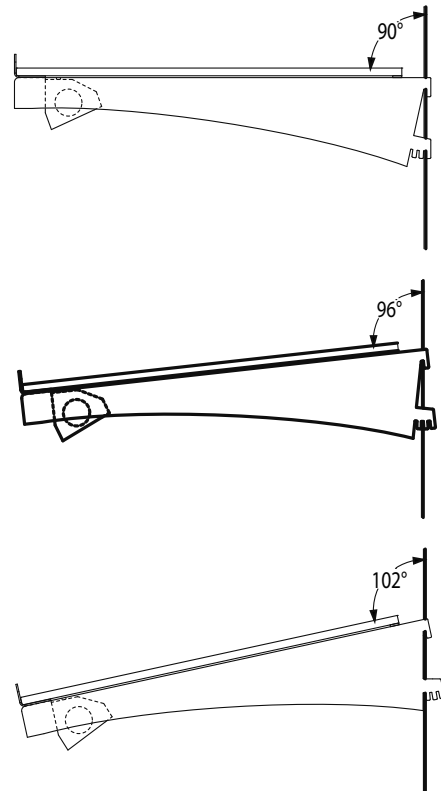

Sliding Door Removal And Reinstall

Sliding Door Removal

Open the door almost completely. Firmly grasp both sides of the door. Lift the door up and move it until it enters a notch and can be lifted higher. Tilt the bottom out without removing the top. Use the top to gently return the spring to the closed position. Remove the door from the top track.

Sliding Door Reinstall

There is a notch in the top inside corner of the door. Put the spring in the door's notch and move the spring to the open position. Put the top into the track and find the notch where the door can be lifted higher. Set bottom of the door into the track.

Night & Security Cover Operations

At the factory, the keys are taped to the display case. Pull the cover down, turn the key 90° to lock.

Section 3 Operation

DANGER

The on-site supervisor is responsible for ensuring that operators are made aware of the inherent dangers of operating this equipment.

DANGER

Do not operate any appliance with a damaged cord or plug. All repairs must be performed by a qualified service company.

DANGER

Never stand on the unit! They are not designed to hold the weight of an adult, and may collapse or tip if misused in this manner.

Warning

Do not contact moving parts.

Warning

All covers and access panels must be in place and properly secured, before operating this equipment.

Warning

Damp or wet hands may stick to cold surfaces.

Warning

Never use sharp objects or tools to remove ice or frost. Do not use mechanical devices or other means to accelerate the defrosting process.

Warning

The operator of this equipment is solely responsible for ensuring safe holding temperature levels for all food items. Failure to do so could result in unsafe food products for customers.

Caution

Do not block the supply and return air grills or the air space around the air grills. Keep plastic wrappings, paper, labels, etc. from being airborne and lodging in the grills. Failure to keep the air grills clear will result in unsatisfactory operation of the system.

Operation

An ON/OFF switch is located on the remote control panel. Simply turn the switch to ON to begin operation. There is a second ON/OFF switch on the remote control panel for the lights.

Delfield's Air Screen Merchandisers are designed to maintain an operational temperature of 36°F - 40°F at 80°F ambient room temperature (2°C - 4°C at 27°C) in 55% or lower relative humidity.

Note

If humidity is above 55%, condensation on the glass will be present.

Proper airflow is critical to maintaining temperature.

- Overloading the merchandiser, restricting the air flow, and continuous opening and closing of the doors will hinder the unit's ability to maintain operational temperatures.
- Do not interfere with the airflow by placing product over the air return openings.
- The Air Diffuser Pan Assembly must be properly in place at the bottom of the merchandising case, with the air return openings on the customer side.
- After cleaning or servicing the Front Deflector Glass, Honeycomb Diffuser and Airduct Plexiglas Panel must be replaced properly.

Temperature Control Settings

Note

Adjustments should be made by a service professional only. Contact KitchenCare (844) 724-2273 or your local service agent for assistance. Delfield is not responsible for charges incurred while adjusting the temperature control.

Note

The temp displayed on the control is the coil temperature not the box temperature.

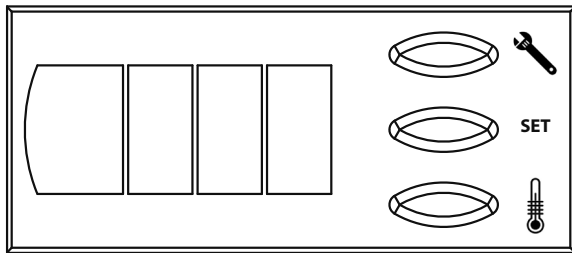

READING THE TEMPERATURE AT DEFROST SENSOR

1. Push the bottom Thermometer button once to display the temperature at the defrost sensor.

CHANGE COIL TEMPERATURE

1. Push the SET button once to display the temperature.
2. Push the upper or the lower button to select the new value.
Make small incremental adjustments if a temperature adjustment is necessary.
3. Push the SET button to save the setting.

Parameter	Screen Name	36"	48"	Units	Description
Set Point, Coil Temperature	Cutout	26.1	29.6	F°	Reference point, can be cut-in or cut-out based on a positive or negative differential

CHANGE OTHER PARAMETER VALUES

1. Push the upper button for a couple of seconds until a parameter r01 is shown.
2. Push the upper or the lower button and find that parameter screen name you want to change.
3. Push the SET button until the parameter value is shown.
4. Push the upper or the lower button and select the new value.
5. Push the middle button again to save the value.

Parameter	Screen Name	36"	48"	Units	Parameter Description
Differential	r01	7	7	F°	A positive differential value gives the cut-in value, while a negative value creates a cut-out value
Unit Temperature	r05	1	1	F°	C=0/F=1. Celsius or Fahrenheit readout in display
Night Setback Value	r13	1.9	-7	F°	Allows for a warmer or colder set point with night curtain in down position
Defrost Method	d01	1	1		1=Electric or off-cycle
Defrost Stop Temperature	d02	46.4	46.4	F°	Temperature that stops defrost (defrost termination)
Interval Between Defrosts	d03	3	3	Hours	Time in between defrost

Section 4 Maintenance

⚠ DANGER

It is the responsibility of the equipment owner to perform a Personal Protective Equipment Hazard Assessment to ensure adequate protection during maintenance procedures.

⚠ DANGER

Failure to disconnect the power at the main power supply disconnect could result in serious injury or death. The power switch DOES NOT disconnect all incoming power.

⚠ DANGER

Disconnect electric power at the main power disconnect for all equipment being serviced. Observe correct polarity of incoming line voltage. Incorrect polarity can lead to erratic operation.

⚠ Warning

Never use sharp objects or tools to remove ice or frost. Do not use mechanical devices or other means to accelerate the defrosting process.

Maintenance	Daily	Weekly	Monthly	After Prolonged Shutdown	At Start-Up
Interior	X			X	X
Exterior	X			X	X
Drain		X		X	X
Condenser Coil			X	X	X

INTERIOR CLEANING

Notice

When cleaning interior and exterior of unit, care should be taken to avoid the front power switch and the rear power cord. Keep water and/or cleaning solutions away from these parts.

Notice

Never use a high-pressure water jet for cleaning or hose down or flood interior or exterior of units with water. Do not use power cleaning equipment, steel wool, scrapers or wire brushes on stainless steel or painted surfaces.

The interior can be cleaned using soap and warm water. If

Cleaning and Sanitizing Procedures

⚠ Caution

Maintenance and servicing work other than cleaning as described in this manual must be done by an authorized service personnel.

GENERAL

⚠ Warning

When using cleaning fluids or chemicals, rubber gloves and eye protection (and/or face shield) must be worn.

Owners and operators are responsible for maintaining the equipment in accordance with the instructions in this manual. Maintenance procedures are not covered by the warranty.

this isn't sufficient, try ammonia and water or a nonabrasive liquid cleaner.

Preventing Blower Coil Corrosion

To help prevent corrosion of the blower coil, store all acidic items, such as pickles and tomatoes, in seal-able containers. Immediately wipe up all spills.

EXTERIOR CLEANING**Notice**

Never use an acid based cleaning solution on exterior panels! Many food products have an acidic content, which can deteriorate the finish. Be sure to clean the stainless steel surfaces of ALL food products.

Clean the area around the unit as often as necessary to maintain cleanliness and efficient operation.

Wipe gasket and surfaces with a damp cloth rinsed in water to remove dust and dirt from the outside of the unit. Always rub with the "grain" of the stainless steel to avoid marring the finish. If a greasy residue persists, use a damp cloth rinsed in a mild dish soap and water solution. Wipe dry with a clean, soft cloth.

Never use steel wool or abrasive pads for cleaning. Never use chlorinated, citrus based or abrasive cleaners.

Stainless steel exterior panels have a clear coating that is stain resistant and easy to clean. Products containing abrasives will damage the coating and scratch the panels. Daily cleaning may be followed by an application of stainless steel cleaner which will eliminate water spotting and fingerprints. Early signs of stainless steel breakdown are small pits and cracks. If this has begun, clean thoroughly and start to apply stainless steel cleaners in attempt to restore the steel.

PLEXIGLAS, INCLUDING BAFFLES

Wet a clean cloth with lukewarm water and dishwashing liquid. Apply only light pressure, rinse with clean water and blot dry with a damp chamois. For excessively dirty surfaces, rinse surface dirt off before washing. Fine scratches will disappear when you polish by hand with a plastic cleaner polish.

Notice

Never use window sprays, kitchen scouring compounds or solvents such as acetone, gasoline, benzene, alcohol, carbon tetrachloride or lacquer thinner to clean plexiglas.

SLIDING DOORS

Frequent, regular cleaning with a mild soap and water solution will keep the tracks free of foreign matter and will insure many years of service. The glass may be cleaned with one of the many commercial glass cleaners currently available.

DRAIN

Each unit has a drain located inside the unit that removes the condensation from the evaporator coil and routes it to an external condensate evaporator pan. Each drain can become loose or disconnected during normal use. If you notice water accumulation on the inside of the unit, be sure the drain tube is connected to the evaporator drain pan. If water is collecting underneath the unit, make sure the end of the drain tube is in the condensate evaporator. The leveling of the unit is important as the units are designed to drain properly when level. Be sure all drain lines are free of obstructions.

CLEANING THE CONDENSER COIL

In order to maintain proper refrigeration performance, the condenser fins must be cleaned of dust, dirt and grease regularly. It is recommended that this be done monthly. If conditions are such that the condenser is totally blocked in a month, the frequency of cleaning should be increased. Clean the condenser with a vacuum cleaner or stiff brush. If extremely dirty, a commercially available condenser cleaner may be required.

Failure to maintain a clean condenser coil can initially cause high temperatures and excessive run times. Continuous operation with a dirty or clogged condenser coil can result in compressor failure. Neglecting the condenser coil cleaning procedures will void any warranties associated with the compressor and cost to replace the compressor.

Section 5 Controls

Control Parameter Factory Settings

Control Connection S3 = Thermostat Probe

Control Connection S5 = Defrost Probe

NOTE: ASM-60 values are for reference only, it is no longer in production as of Nov. 2015.

Parameter	Code	ASM-36 Value	ASM-48 Value	ASM-60 Value
Cutout		26.0°F	29.6°F	25.1°F
Differential	r01	7.2°F	7.2°F	8.4°F
Max cutout	r02	32°F	41°F	41°F
Min cutout	r03	10.4°F	10.4°F	10.4°F
Temp. offset	r04	0	0	0
Temp.unit (0=°C/1=°F)	r05	°F	°F	°F
Adjust S4	r09	0	0	0
Adjust S3	r10	0	0	0
Main switch	r12	-001	1	1
Night offset	r13	1.9	-4	1.9
Ther. S4 %	r15	0	0	0
Th. offset (0=Off/1=On)	r39	off	off	off
Th. offset K	r40	0	0	0
Alarm delay	A03	0	90	90
DoorOpen del	A04	60	0	0
Pulldown del	A12	90	90	90
HighLim Air	A13	57.2°F	57.2°F	57.2°F
LowLim Air	A14	21.0°F	21.0°F	21.0°F
Alarm Delay DI1	A27	0	0	0
Alarm Delay DI2	A28	0	0	0
Alarm S4 %	A36	0	0	0
Min. On time	c01	2	2	2
Min.Off time	c02	0	0	0
Cmp relay NC (0=Off/1=On)	c30	off	off	off
Def. method (0=non/1=Elec/2=gas/3=brine)	d01	EI	EI	EI
Def.StopTemp	d02	46.4°F	46.4°F	51.4°F
Def.Interval	d03	3	3	3
Max Def.time	d04	45	45	45
Time stagg.	d05	0	0	0
DripOff time	d06	0	0	0
FanStartDel	d07	0	0	0
FanStartTemp	d08	32	32	32
FanDuringDef	d09	1	1	1
DefStopSens.	d10	1	1	1
Pump dwn del	d16	0	0	0
MaxTherRunT.	d18	3	4	3
CutoutS5Dif., (20=disable)	d19	36	20	36
Fan stop CO (0=No/1=Yes)	F01	No	No	No
Fan del. CO	F02	0	0	0
Fan stop temperature (over 50°C/122°F disables setting)	F04	122	122	122
HACCP temperature	H01	320*	320*	320*
Peak temperature	H10	32*	32*	32*
Selection of function (0=No HACCP function)	H11	0	0	0
Alarm limit	H12	46.4*	46.4*	46.4*
Time delay for the alarm	H13	30*	30*	30*
Selection of sensors for the measuring	H14	100*	100*	100*
1 of 6 start times for defrost. Setting of hours. 0=OFF	T01	0	0	0
1 of 6 start times for defrost. Setting of minutes. 0=OFF	T11	0	0	0
1 of 6 start times for defrost. Setting of hours. 0=OFF	T02	0	0	0

1 of 6 start times for defrost. Setting of minutes. 0=OFF	T12	0	0	0
1 of 6 start times for defrost. Setting of hours. 0=OFF	T03	0	0	0
1 of 6 start times for defrost. Setting of minutes. 0=OFF	T13	0	0	0
1 of 6 start times for defrost. Setting of hours. 0=OFF	T04	0	0	0
1 of 6 start times for defrost. Setting of minutes. 0=OFF	T14	0	0	0
1 of 6 start times for defrost. Setting of hours. 0=OFF	T05	0	0	0
1 of 6 start times for defrost. Setting of minutes. 0=OFF	T15	0	0	0
1 of 6 start times for defrost. Setting of hours. 0=OFF	T06	0	0	0
Clock: Hour setting	t07	<i>Current Hour</i>	<i>Current Hour</i>	<i>Current Hour</i>
Clock: Minute setting	t08	<i>Current Minute</i>	<i>Current Minute</i>	<i>Current Minute</i>
Clock: Date setting	t45	<i>Current Date</i>	<i>Current Date</i>	<i>Current Date</i>
Clock: Month setting	t46	<i>Current Month</i>	<i>Current Month</i>	<i>Current Month</i>
Clock: Year setting	t47	<i>Current Year</i>	<i>Current Year</i>	<i>Current Year</i>
Delay of output signal after start-up	o01	1	1	1
Digital input signal - DI1	o02	6	6	6
Access code 1 (Access to all settings)	o05	0	0	0
SensorConfig (0=Pt/1=PTC/2=NTC)	o06	ntc	ntc	ntc
Display step (Yes=0.5°/No=0.1°)	o15	no	no	no
MaxHoldTime	o16	0	0	0
Disp. S4 %	o17	0	0	0
Digital input signal - D2 (0=Off/1=On)	o37	0	0	0
Case cleaning	o46	0	0	0
Selection of application	o61	1	1	1
Transfer a set of presettings to the controller	o62	0	0	0
Access code 2 (Access to adjustments)	o64	0	0	0
Save as factory setting (0=Off/1=On)	o67	off	off	off
S5 Defrost temp.	u09	<i>View Probe Value</i>	<i>View Probe Value</i>	<i>View Probe Value</i>
Status on DI1 input (0=Off/1=On)	u10	<i>Current Status</i>	<i>Current Status</i>	<i>Current Status</i>
S3 Thermostat air temp.	u12	<i>View Probe Value</i>	<i>View Probe Value</i>	<i>View Probe Value</i>
Status on night operation (0=Off/1=On)	u13	<i>Current Status</i>	<i>Current Status</i>	<i>Current Status</i>
S4 Display air temp.	u16	<i>View Probe Value</i>	<i>View Probe Value</i>	<i>View Probe Value</i>
Thermostat temperature	u17	<i>Current Temp</i>	<i>Current Temp</i>	<i>Current Temp</i>
Read the present regulation reference	u28	<i>Current Reading</i>	<i>Current Reading</i>	<i>Current Reading</i>
Status on DI2 output (0=Off/1=On)	u37	<i>Current Status</i>	<i>Current Status</i>	<i>Current Status</i>
Temperature shown on display	u56	<i>Current Air Temp</i>	<i>Current Air Temp</i>	<i>Current Air Temp</i>
Measured temperature for alarm thermostat	u57	<i>Current Temp</i>	<i>Current Temp</i>	<i>Current Temp</i>
Status on relay for cooling	u58	<i>Current Status**</i>	<i>Current Status**</i>	<i>Current Status**</i>
Status on relay for fan	u59	<i>Current Status**</i>	<i>Current Status**</i>	<i>Current Status**</i>
Status on relay for defrost	u60	<i>Current Status**</i>	<i>Current Status**</i>	<i>Current Status**</i>
Status on relay for alarm	u62	<i>Current Status**</i>	<i>Current Status**</i>	<i>Current Status**</i>

NOTE: * HACCP is disabled according to H11 setting.

NOTE: ** Can be controlled manually, but only when r12=-1

Section 6 Diagrams

ASM-36 & ASM-48

VOLTAGE (NO CONDENSATE EVAP): 115V-60HZ-1PH
 VOLTAGE (WITH CONDENSATE EVAP): 115/208-220V-60HZ-1PH

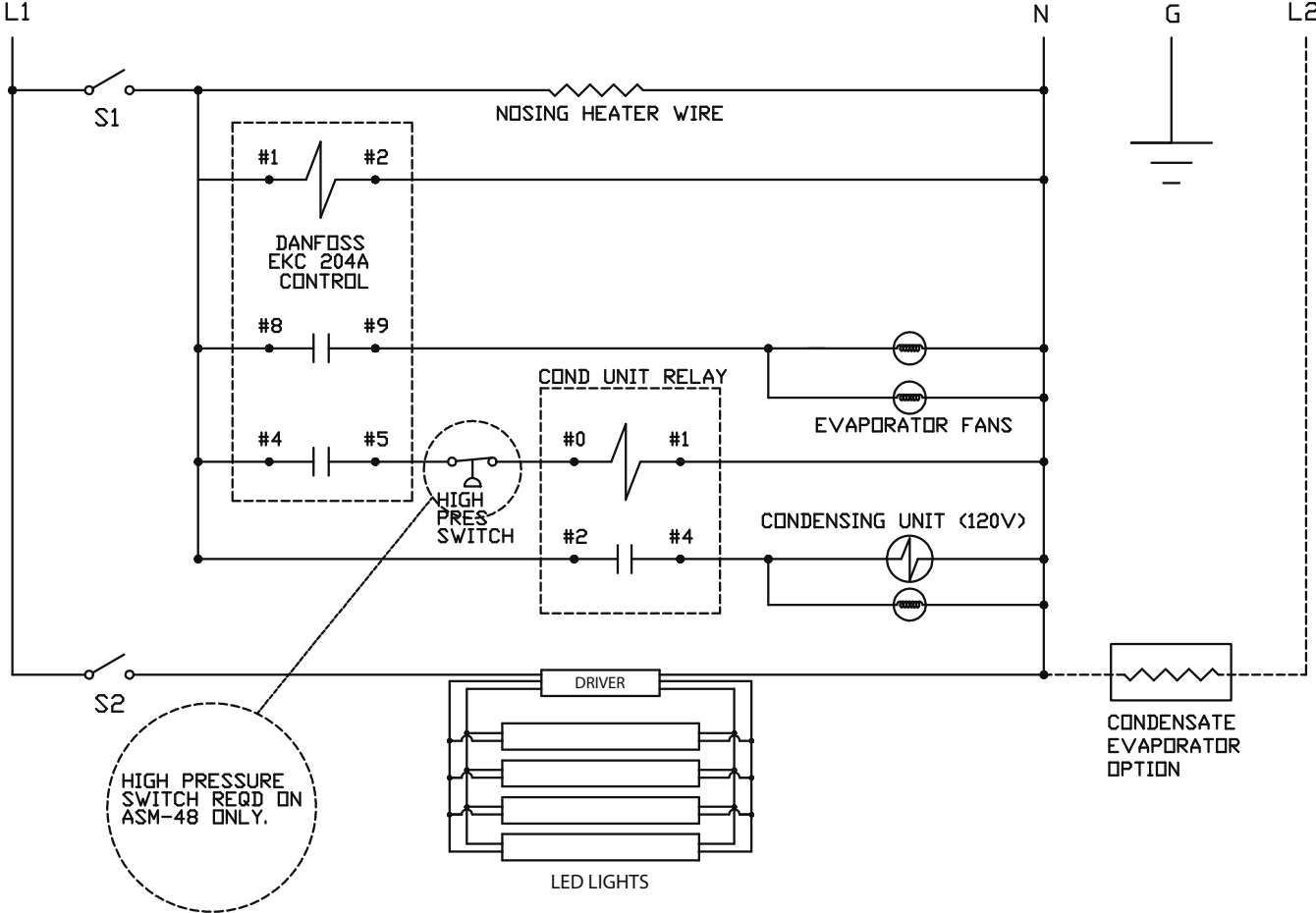

ASM-60

NOTE: For reference only. ASM-60 is no longer in production as of Nov. 2015.

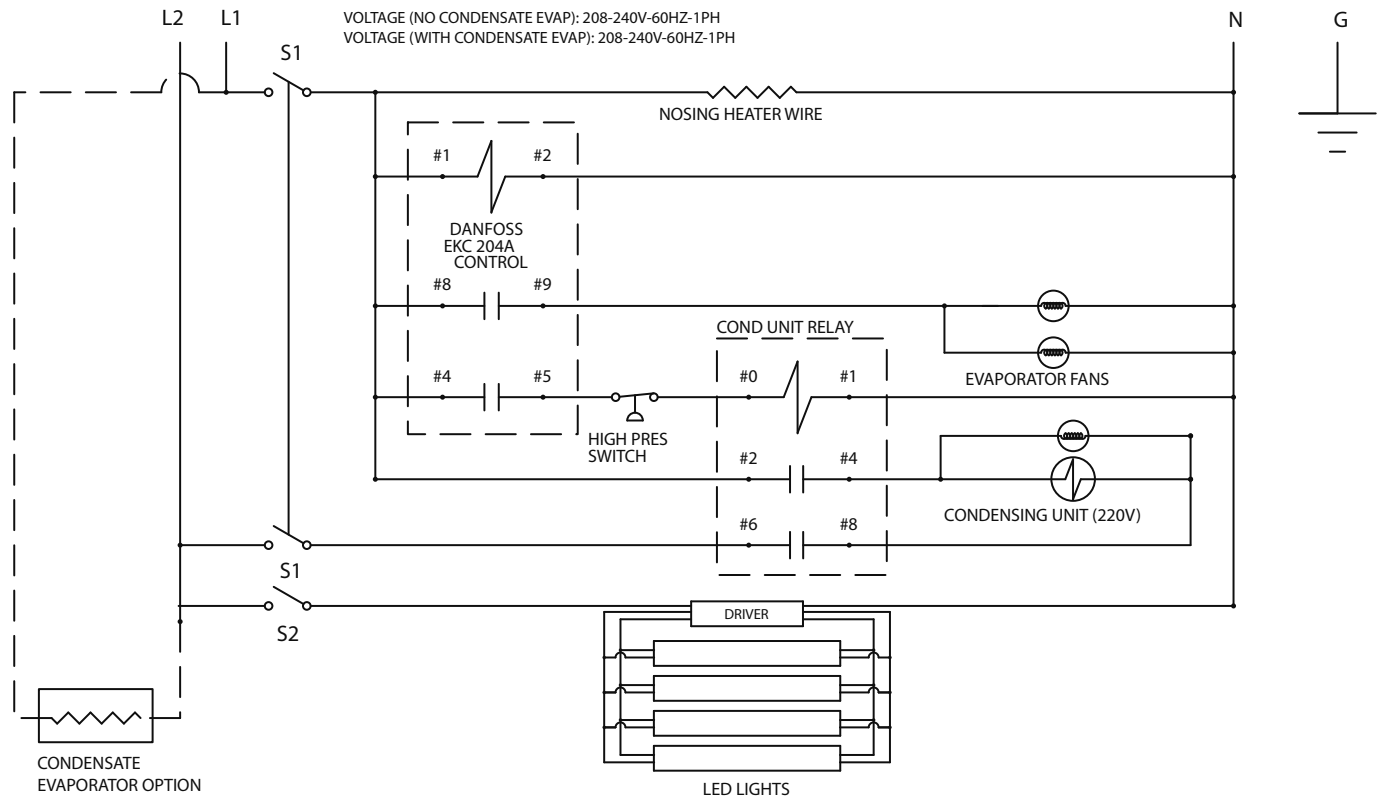

Remote Models ASM-36R, ASM-48R, ASM-60R*

NOTE: For reference only. ASM-60 is no longer in production as of Nov. 2015.

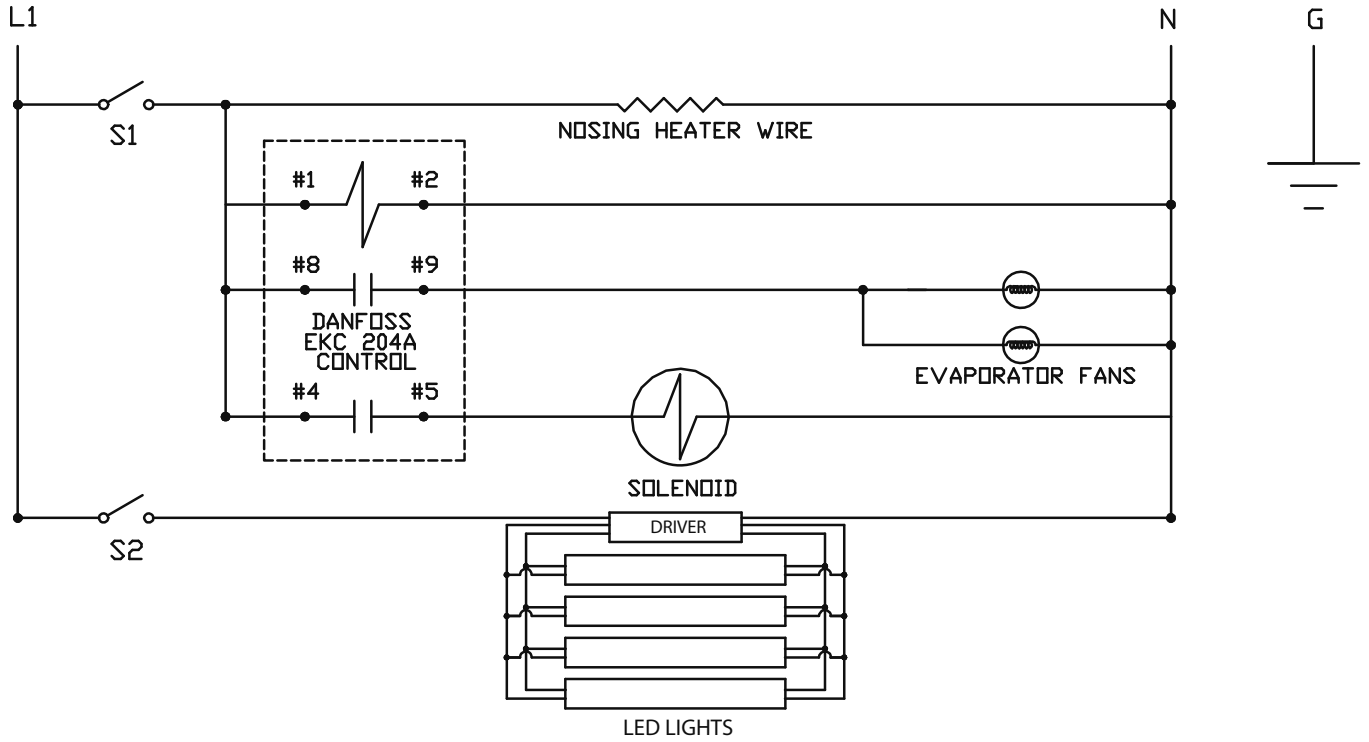

THIS PAGE INTENTIONALLY LEFT BLANK



DELFIELD
980 SOUTH ISABELLA ROAD, MOUNT PLEASANT, MI 48858

800-733-8821
WWW.DELFIELD.COM

Every new piece of Manitowoc Foodservice equipment comes with KitchenCare™ and you choose the level of service that meets your operational needs from one restaurant to multiple locations.

StarCare – Warranty & lifetime service, certified OEM parts, global parts inventory, performance audited

ExtraCare — CareCode, 24/7 Support, online/mobile product information

LifeCare – Install & equipment orientation, planned maintenance, KitchenConnect™, MenuConnect

Talk with KitchenCare™ • 1-844-724-CARE • www.mtwkitchencare.com



To learn how Manitowoc Foodservice and its leading brands can equip you, visit our global web site at www.manitowocfoodservice.com, then discover the regional or local resources available to you.

