

Dispensing Models

Service and Installation Manual

Please read this manual completely before attempting to install or operate this equipment! **Notify carrier of damage!** Inspect all components immediately.



DIS

Drop-In Dish Dispensers



CAB

Mobile Enclosed Dish
Dispensers



CT

Mobile Cantilever Tray/
Rack Dispensers



LT

Drop-In Tray Dispensers



TT

Mobile Tray/Rack
Dispensers



CD

Disposable Cup
Dispensers

**Also in this
manual:**

- ND
- SB
- T
- T-H
- T2
- FT2-SN



CAUTION

Important information
Read before use
Please save these instructions!

Important Warning And Safety Information



WARNING

Read This Manual Thoroughly Before Operating, Installing, Or Performing Maintenance On The Equipment.



WARNING

Failure To Follow Instructions In This Manual Can Cause Property Damage, Injury Or Death.



WARNING

Do Not Store Or Use Gasoline Or Other Flammable Vapors Or Liquids In The Vicinity Of This Or Any Other Appliance.



WARNING

Unless All Cover And Access Panels Are In Place And Properly Secured, Do Not Operate This Equipment.



WARNING

This Appliance Is Not Intended For Use By Persons Who Lack Experience Or Knowledge, Unless They Have Been Given Supervision Or Instruction Concerning Use Of The Appliance By A Person Responsible For Their Safety.



WARNING

This Appliance Is Not To Be Played With.



WARNING

Do Not Clean With Water Jet.



WARNING

Do Not Use Electrical Appliances Inside The Food Storage Compartment Of This Appliance.



CAUTION

Observe the following:

- Minimum clearances must be maintained from all walls and combustible materials.
- Keep the equipment area free and clear of combustible material.
- Allow adequate clearance for air openings.
- Operate equipment only on the type of electricity indicated on the specification plate.
- Unplug the unit before making any repairs.
- Retain this manual for future reference.

Contents

Receiving & Inspecting Equipment	3
Serial Number Location	4
Warranty Information.....	4
Regulatory Certifications.....	4
Specifications	5-8
Installation	9
Operation.....	10-11
Adjusting Self-Leveling Dispenser	12-13
Maintenance.....	14
Troubleshooting Reference Chart	15
Wiring Diagrams	16
Replacement Parts List.....	17-18
Standard Labor Guidelines	19

Receiving And Inspecting The Equipment

Even though most equipment is shipped crated, care should be taken during unloading so the equipment is not damaged while being moved into the building.

1. Visually inspect the exterior of the package and skid or container. Any damage should be noted and reported to the delivering carrier immediately.
2. If damaged, open and inspect the contents with the carrier.
3. In the event that the exterior is not damaged, yet upon opening, there is concealed damage to the equipment notify the carrier. Notification should be made verbally as well as in written form.
4. Request an inspection by the shipping company of the damaged equipment. This should be done within 10 days from receipt of the equipment.

5. Check the lower portion of the unit to be sure the casters are not bent.
6. Retain all crating material until an inspection has been made or waived.

Uncrating the Equipment

First cut and remove the banding from around the crate. Remove the front of the crate material, use of some tools will be required. If the unit is on legs remove the top of the crate as well and lift the unit off the skid. If the unit is on casters it can be rolled off the skid.

Serial Number Location

Dish Dispensers: The serial number is located on the dispenser housing.

Tray & Rack Dispensers: The serial number is located on the back of the unit or the underside of the flange.

Always have the serial number of your unit available when calling for parts or service.

©2013 The Delfield Company. All rights reserved. Reproduction without written permission is prohibited. "Delfield" & "Shelleymatic" are registered trademarks of The Delfield Company.

Warranty Information

Visit http://www.delfield.com/minisite/service/warranty_info to:

- Register your product for warranty.
- Verify warranty information.
- View and download a copy of your warranty.

Regulatory Certifications

All models are certified by:



National Sanitation Foundation (NSF)

Electrical models are also certified by:



Underwriters Laboratories (UL)

Underwriters Laboratories of Canada (ULC)

Specifications

Dish Dispensers — Mobile Two Stack				
<i>Model</i>	<i>Max. Dish Diameter</i>	<i>Voltage (60hz, 1Ph)</i>	<i>Amps</i>	<i>Nema Plug</i>
CAB2-500	5.00"	N/A	N/A	N/A
CAB2-575	5.75"	N/A	N/A	N/A
CAB2-650	6.50"	N/A	N/A	N/A
CAB2-725	7.25"	N/A	N/A	N/A
CAB2-813	8.12"	N/A	N/A	N/A
CAB2-913	9.12"	N/A	N/A	N/A
CAB2-1013	10.12"	N/A	N/A	N/A
CAB2-1200	12.00"	N/A	N/A	N/A
CAB2-1450	14.50"	N/A	N/A	N/A
CAB2-500ET	5.00"	120	11.0	5-20P
CAB2-575ET	5.75"	120	11.0	5-20P
CAB2-650ET	6.50"	120	11.0	5-20P
CAB2-725ET	7.25"	120	11.0	5-20P
CAB2-813ET	8.12"	120	11.0	5-20P
CAB2-913ET	9.12"	120	11.0	5-20P
CAB2-1013ET	10.12"	120	11.0	5-20P
CAB2-1200ET	12.00"	120	11.0	5-20P
CAB2-1450ET	14.50"	120	11.0	5-20P
CAB2-813QT	8.12"	120	11.0	5-20P
CAB2-913QT	9.12"	120	11.0	5-20P
CAB2-1013QT	10.12"	120	11.0	5-20P
CAB2-1200QT	12.00"	120	11.0	5-20P
CAB2-1450QT	14.50"	120	11.0	5-20P
Dish Dispensers — Mobile Three Stack				
<i>Model</i>	<i>Max. Dish Diameter</i>	<i>Voltage (60hz, 1Ph)</i>	<i>Amps</i>	<i>Nema Plug</i>
CAB3-500	5.00"	N/A	N/A	N/A
CAB3-575	5.75"	N/A	N/A	N/A
CAB3-650	6.50"	N/A	N/A	N/A
CAB3-725	7.25"	N/A	N/A	N/A
CAB3-813	8.12"	N/A	N/A	N/A
CAB3-913	9.12"	N/A	N/A	N/A
CAB3-1013	10.12"	N/A	N/A	N/A
CAB3-1200	12.00"	N/A	N/A	N/A
CAB3-1450	14.50"	N/A	N/A	N/A
CAB3-500ET	5.00"	208	10.6	6-20P

CAB3-575ET	5.75"	208	10.6	6-20P
CAB3-650ET	6.50"	208	10.6	6-20P
CAB3-725ET	7.25"	208	10.6	6-20P
CAB3-813ET	8.12"	208	10.6	6-20P
CAB3-913ET	9.12"	208	10.6	6-20P
CAB3-1013ET	10.12"	208	10.6	6-20P
CAB3-1200ET	12.00"	208	10.6	6-20P
CAB3-1450ET	14.50"	208	10.6	6-20P
CAB3-813QT	8.12"	208	10.6	6-20P
CAB3-913QT	9.12"	208	10.6	6-20P
CAB3-1013QT	10.12"	208	10.6	6-20P
CAB3-1200QT	12.00"	208	10.6	6-20P
CAB3-1450QT	14.50"	208	10.6	6-20P
Dish Dispensers — Mobile Four Stack				
<i>Model</i>	<i>Max. Dish Diameter</i>	<i>Voltage (60hz, 1Ph)</i>	<i>Amps</i>	<i>Nema Plug</i>
CAB4-500	5.00"	N/A	N/A	N/A
CAB4-575	5.75"	N/A	N/A	N/A
CAB4-650	6.50"	N/A	N/A	N/A
CAB4-725	7.25"	N/A	N/A	N/A
CAB4-813	8.12"	N/A	N/A	N/A
CAB4-913	9.12"	N/A	N/A	N/A
CAB4-1013	10.12"	N/A	N/A	N/A
CAB4-1200	12.00"	N/A	N/A	N/A
CAB4-1450	14.50"	N/A	N/A	N/A
CAB4-500ET	5.00"	208	14.2	6-20P
CAB4-575ET	5.75"	208	14.2	6-20P
CAB4-650ET	6.50"	208	14.2	6-20P
CAB4-725ET	7.25"	208	14.2	6-20P
CAB4-813ET	8.12"	208	14.2	6-20P
CAB4-913ET	9.12"	208	14.2	6-20P
CAB4-1013ET	10.12"	208	14.2	6-20P
CAB4-1200ET	12.00"	208	14.2	6-20P
CAB4-1450ET	14.50"	208	14.2	6-20P
CAB4-813QT	8.12"	208	14.2	6-20P
CAB4-913QT	9.12"	208	14.2	6-20P
CAB4-1013QT	10.12"	208	14.2	6-20P
CAB4-1200QT	12.00"	208	14.2	6-20P
CAB4-1450QT	14.50"	208	14.2	6-20P



Specifications

Dish Dispensers — Drop-In

Model	Flange Diameter	Cutout Diameter	Dish Diameter	Voltage (60Hz, 1Ph)	Amps	Nema Plug
DIS-500	8.37"	7.75"	5.00"	N/A	N/A	N/A
DIS-575	9.12"	8.50"	5.75"	N/A	N/A	N/A
DIS-650	9.87"	9.25"	6.50"	N/A	N/A	N/A
DIS-725	10.62"	10.00"	7.25"	N/A	N/A	N/A
DIS-813	11.50"	10.87"	8.12"	N/A	N/A	N/A
DIS-913	12.50"	11.87"	9.12"	N/A	N/A	N/A
DIS-1013	13.50"	12.87"	10.12"	N/A	N/A	N/A
DIS-1200	15.37"	14.75"	12.00"	N/A	N/A	N/A
DIS-1450	17.88"	17.25"	14.50"	N/A	N/A	N/A

Dish Dispensers — Drop-In/Heated

Model	Flange Diameter	Cutout Diameter	Dish Diameter	Voltage (60Hz, 1Ph)	Amps	Nema Plug
DIS-500-ET	8.37"	7.75"	5.00"	120	5.5	5-15P
DIS-575-ET	9.12"	8.50"	5.75"	120	5.5	5-15P
DIS-650-ET	9.87"	9.25"	6.50"	120	5.5	5-15P
DIS-725-ET	10.62"	10.00"	7.25"	120	5.5	5-15P
DIS-813-ET	11.50"	10.87"	8.12"	120	5.5	5-15P
DIS-913-ET	12.50"	11.87"	9.12"	120	5.5	5-15P
DIS-1013-ET	13.50"	12.87"	10.12"	120	5.5	5-15P
DIS-1200-ET	15.37"	14.75"	12.00"	120	5.5	5-15P
DIS-1450-ET	17.88"	17.25"	14.50"	120	5.5	5-15P

Dish Dispensers — Drop-In/Heated/Quick Temp

Model	Flange Diameter	Cutout Diameter	Dish Diameter	Voltage (60Hz, 1Ph)	Amps	Nema Plug
DIS-813-QT	11.50"	10.87"	8.12"	120	5.5	5-15P
DIS-913-QT	12.50"	11.87"	9.12"	120	5.5	5-15P
DIS-1013-QT	13.50"	12.87"	10.12"	120	5.5	5-15P
DIS-1200-QT	15.37"	14.75"	12.00"	120	5.5	5-15P
DIS-1450-QT	17.88"	17.25"	14.50"	120	5.5	5-15P

Disposable Cup Dispensers

Model	Flange Diameter	Cutout Diameter	Dish Diameter
CD	7.38"	5.12"	2.50"-4.63"

Bread Dispensers

Model	Flange Diameter	Cutout Diameter	Bread Dimension	Ship Weight
SB-1	6.50" X 6.50"	5.87" X 5.87"	5.25" X 5.25"	15lbs (7kg)

Specifications, *continued*

Mobile Cantilevered Tray and Rack Dispensers					
<i>Model</i>	<i>Maximum Tray Size</i>	<i>Ship Weight</i>	<i>Model</i>	<i>Maximum Tray Size</i>	<i>Ship Weight</i>
CT-1216	12" x 16"	106lbs/48kg	CT-1622	16" x 22"	159lbs/72kg
CT-1221	12" x 21"	132lbs/60kg	CT-1826	18" x 26"	165lbs/75kg
CT-1418	14" x 18"	145lbs/66kg	CT-2020	20" x 21"	168lbs/76kg
CT-1422	14" x 22"	145lbs/66kg			

Napkin Dispensers			
<i>Model</i>	<i>Cutout Dimension</i>	<i>Napkin Dimension</i>	<i>Ship Weight</i>
ND-45	5.62" X 7.00"	4.00" X 5.37"	12lbs (5kg)
ND-47	5.87" X 8.75"	4.25" X 7.12"	12lbs (5kg)
ND-48	6.12" X 9.62"	4.50" X 8.00"	12lbs (5kg)
ND-57	6.75" X 8.62"	5.12" X 7.00"	12lbs (5kg)
ND-59	6.37" X 10.37"	4.75" X 8.75"	12lbs (5kg)
ND-67	8.5" X 8.75"	6.87" X 7.12"	12lbs (5kg)

Mobile Enclosed Tray And Rack Dispensers		
<i>Model</i>	<i>Maximum Tray Size</i>	<i>Ship Weight</i>
T-1014	10" x 15" (25.4cm x 38.1cm)	150lbs/68kg
T-1216	12" x 16" (30.5cm x 40.6cm)	153lbs/69kg
T-1221	12" x 21" (30.5cm x 53.3cm)	162lbs/74kg
T-1418	14" x 18" (35.6cm x 45.7cm)	153lbs/69kg
T-1422	14" x 22" (35.6cm x 55.9cm)	162lbs/74kg
T-1622	16" x 22" (40.6cm x 55.9cm)	177lbs/80kg
T-1826	18" x 26" (45.7cm x 66.0cm)	210lbs/95kg
T-2020	20" x 21" (50.8cm x 53.3cm)	175lbs/79kg
T2-1014	10" x 15" (25.4cm x 38.1cm)	177lbs/80kg
T2-1216	12" x 16" (30.5cm x 40.6cm)	177lbs/80kg
T2-1221	12" x 21" (30.5cm x 53.3cm)	185lbs/84kg

Heated Mobile Enclosed Tray And Rack Dispensers				
<i>Model</i>	<i>Capacity</i>	<i>Amp</i>	<i>Ship Weight</i>	<i>Nema Plug</i>
T-1221H	12.00" X 21.00"	6.34	127lbs (58kg)	5-15p
T-1418H	14.00" X 18.00"	6.34	155lbs (70kg)	5-15p
T-1422H	14.00" X 22.00"	12.7	155lbs (70kg)	5-20p
T-1826H	18.00" X 26.00"	12.7	195lbs (88kg)	5-20p
T-2020H	20.00" X 21.00"	12.7	185lbs (84kg)	5-20p



Specifications, *continued*

Two Stack, Heated Mobile Enclosed Tray And Rack Dispensers

T2-1221H	12.00" X 21.00"	12.7	185	5-20p
----------	-----------------	------	-----	-------

Mobile Open Frame Tray And Rack Dispensers

<i>Model</i>	<i>Maximum Tray Size</i>	<i>Ship Weight</i>
TT-1014	11"x15"	102lbs (46kg)
TT-1216	12"x16"	102lbs (46kg)
TT-1221	12"x21"	105lbs (48kg)
TT-1418	14"x18"	102lbs (46kg)
TT-1422	14"x22"	105lbs (48kg)
TT-1622	16"x22"	106lbs (48kg)
TT-1826	18"x26"	111lbs (50kg)
TT-2020	20"x21"	111lbs (50kg)

Two Stack, Mobile Open Frame Tray And Rack Dispensers

TT2-1014	11"x15"	113lbs (51kg)
TT2-1216	12"x16"	165lbs (75kg)
TT2-1221	12"x21"	163lbs (74kg)
TT2-1418	14"x18"	165lbs (75kg)
TT2-1422	14"x22"	163lbs (74kg)
TT2-1622	16"x22"	170lbs (77kg)
TT2-1826	18"x26"	179lbs (81kg)
TT2-2020	20"x21"	179lbs (81kg)

Two Stack, Mobile Open Frame Tray And Rack Dispensers With Silverware Bin And Napkin Dispensers

<i>Model</i>	<i>Maximum Tray Size</i>	<i>Ship Weight</i>
FT2-SN-1216	12.00" X 16.00"	289lbs (131kg)
FT2-SN-1418	14.00" X 18.00"	298lbs (131kg)
FT2-SN-1622	16.00" X 22.00"	306lbs (139kg)

Tray/Rack Dispensers

<i>Model</i>	<i>Cutout Size</i>	<i>Model</i>	<i>Cutout Size</i>
LT-1014	11.75" X 21.00"	LT-1826	27.75" X 24.00"
LT-1216	17.75" X 18.00"	LT-2020	22.75" X 26.00"
LT-1221	22.75" X 18.00"	LT2-1014	23.75" X 21.00"
LT-1418	19.75" X 20.00"	LT2-1216	27.75" X 22.00"
LT-1422	23.75" X 20.00"	LT2-1221	27.75" X 27.00"
LT-1622	23.75" X 22.00"		

Installation: Dish Dispensers

Location

Dish dispensers are intended for indoor use only. Drop-in units require a counter cutout of a specific size for proper fit. Refer to specification data for the proper dimensions.



NOTE:

Heated units must have minimum 1" (2.5cm) air gap between the bottom of the dispensing tube and any surface or objects below. Make sure the tube will have proper clearance when installing it into a counter or another piece of equipment.

Stabilizing

CAB models are supplied with casters for your convenience, for ease of cleaning underneath and mobility.



NOTE:

The unit must be installed in a stable condition with the front wheels locked. Locking the front casters after installation is the owner's and operator's responsibility.

Electrical Connection

All heated DIS and CAB models are tested at the factory to assure proper operation.

Refer to the amperage data, the serial tag, your local or the National Electrical Code to be sure the unit is connected to the proper power source. A protected circuit of the correct voltage and amperage must run for connection of the line cord.

DIS models plug into a wall receptacle when used as drop-in models; if they are grouped together in a CAB model, all of the individual DIS power cords are plugged into the receptacle in the CAB cabinet. The master power cord on CAB models plugs into a wall receptacle.



The unit must be disconnected from the power source whenever performing service or maintenance functions.

Installation: Napkin/Cup Dispensers

Dispensers are intended for indoor use only. Napkin and cup units require a counter cutout of a specific size for proper fit. Refer to specification data for the proper dimensions.

Operation Dish Dispensers

Field adjustment

The dispensing height may be adjusted, by following these instructions in order:



Always wear safety glasses when adjusting your dispenser. Springs under tension may recoil when released.



If adjusting a heated model, unplug the unit. Allow the unit to cool completely before handling.

- 1) Lock brakes on mobile units before beginning.
- 2) Unload the dispenser. Remove dispensers from the unit by grasping the black plastic guide posts and lifting the dispenser completely out of the unit.
- 3) There are minimum of six springs per dispenser. When adjusting, make sure each section has the same number and size of springs connected to the tube and make sure the springs are attached in the same order in each section (see diagram 1). This will prevent the load of dishes from binding.

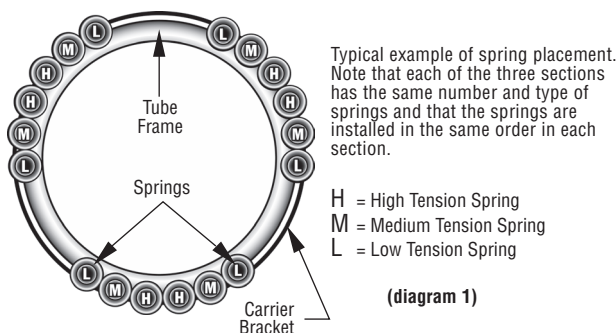

- 4) If the dispensing height is too low, add springs or replace current springs with higher tension springs (springs with higher tension may be ordered from Delfield's Parts and Service Department). Gently engage one spring at a time by hooking the top loop of the spring into the bracket on the tube frame. Then hook the bottom loop of the spring into the carrier bracket (see diagram 2). Add as many springs as necessary.



(diagram 2)
Dish dispenser spring attachments

- 5) If the dishes are resting too high in the unit, remove springs or replace current springs with lower tension springs (springs with lower tension may be ordered from Delfield's Parts and Service Department). Gently disengage one

spring at a time, unhooking the bottom loop out of the carrier bracket first, the unhooking the top loop from the tube frame. (see diagram 2). Remove as many springs as necessary.

- 6) If level is appropriate, return tube to cart or counter. If spring adjustment does not position carrier properly, repeat procedure trying different springs. If this does not work, a different set of springs may be required. To order call Delfield's Parts and Service Department.

Spring Requirements			
Model	Spring Tension		
	Light	Medium	Heavy
DIS-500, 575, 650	3	3	0
DIS-725	0	6	0
DIS-813	3	3	3
DIS-913	3	6	3
DIS-1013	6	6	3
DIS-1200	6	6	6
DIS-1450	6	6	6

Loading instructions

After adjusting for dispensing height, you are ready to load your dishes.

Only load a manageable stack of dishes at a time — approximately 4" (10.2cm) to 5" (12.7cm). Each DIS model dispensing tube will accommodate a 26" (66cm) stack of plates or bowls.



Keep fingers clear from the edge of the opening

If the stack is over the guide posts and is bottomed out, it is full. If stack is over guide posts and not bottomed out (the stack will bounce up and down), adjust the springs. See "Field adjustment" instructions.

Temperature adjustment – ET & QT models only

ET (even-temp) models have either a 400 or 700 watt heating element and an adjustable thermostat. The factory setting for thermostat is "A" which gives an operating temperature of about 165°F (74°C) and effective plate temperatures of between 110°F (43°C) to 120°F (49°C) after about two to three hours of pre-warming.

QT (quick-temp) models have a 700 watt heating element and an adjustable thermostat. The factory setting for thermostat is "E" which gives an operating temperature of about 205°F (96°C) and effective plate temperatures of between 130°F (54°C) to 150°F (66°C) after about two to three hours of pre-warming.

(Continued on the next page.)

Operation: Dish Dispensers, *continued*

The thermostat is located on the bottom of the unit near the fan motor. Use the following directions to adjust.



Unplug the unit and allow the unit to cool completely before handling.

- 1) Lock brakes on mobile units before beginning.
- 2) Unload the dispenser. Remove dispensers from the unit by grasping the black plastic guide posts and lifting the dispenser completely out of the unit. It is not necessary to remove the steel jacket from the dispensing tube.
- 3) Turn the unit on its side.

- 4) Remove filter from bottom of unit. It is not necessary to remove the perforated screen. The screen has access holes in it to allow adjustment of the thermostat. The screen is shown removed in diagram 3 to show the location of the thermostat adjustment screw only.

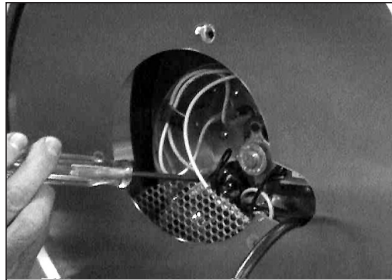

(diagram 3)
Location of thermostat adjustment screw

- 5) Use a small screw-driver to reach the adjustment screw located under the perforated screen (see diagram 3). Turn the screw to the desired setting based on the “thermostat settings chart” shown below.
- 6) Reattach the filter before operating the unit again.

Heated Unit Thermostat Settings	
Temperature Setting	Operating Temperature
A	165°F/ 74°C
B	175°F/ 79°C
C	185°F/ 85°C
D	195°F/ 91°C
E	205°F/ 96°C

Adjusting Self-Leveling Dispensers, Models FT2, TT & LT



**Tools Needed: One small flat head screw driver;
One Phillips head screw driver**

1. Always wear safety glasses when adjusting your dispenser. Also, lock brakes on mobile units before beginning.
2. Unload dispenser and remove stainless steel load tray by lifting straight up and set it aside (see fig. 1). For Models LT skip to step #6.

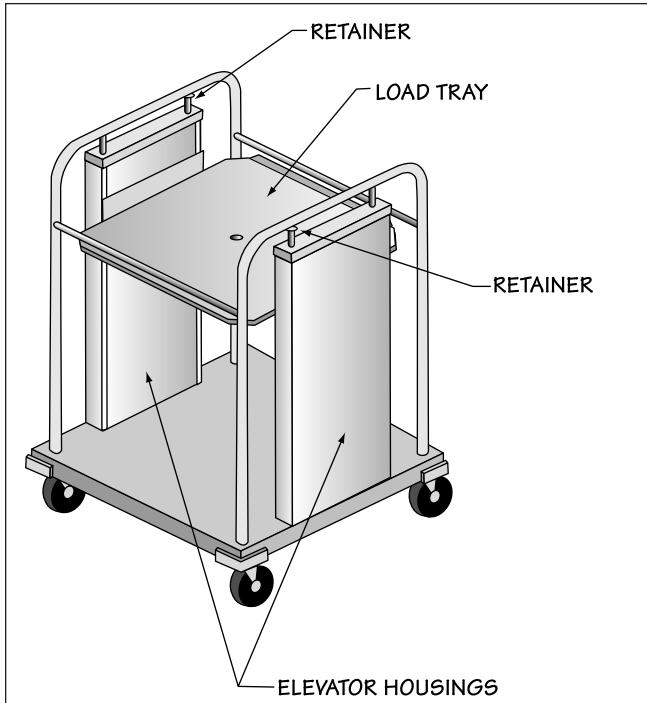

(figure 1) Sample unit

3. Use small regular screw driver to loosen each retainer mounted on stainless steel rod at top of each elevator housing.
4. To remove elevator housing, lift housing straight up to clear the stud on unit base. Then gently swing the bottom of the housing towards the inside of the unit and pull housing out of the unit (see fig. 2). Lay housing on flat surface.



(figure 2) Remove elevator housing

5. Use Phillips head screw driver to remove front panel on the elevator housing (see fig. 3).
6. If carrier is riding too high, you need to remove springs. With carrier all the way to the top, gently disengage one spring at a time, unhooking bottom loop out of carrier bracket (see fig. 4). Remove as many springs as necessary. If carrier is riding too low, you need to add springs. With carrier all the way to the top, gently engage one spring at a time by hooking bottom loop of spring into carrier bracket. Add as many springs as necessary.

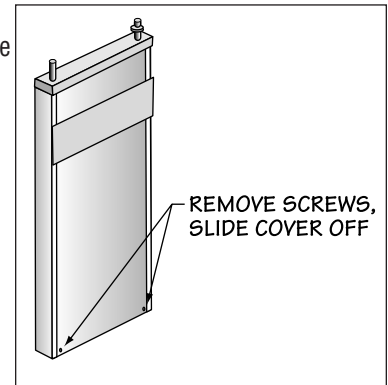

(figure 3) Remove front panel

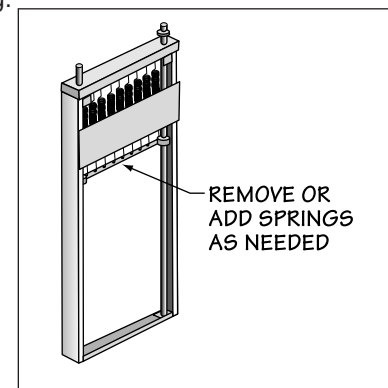

(figure 4) Remove or add springs

7. When finished, put elevator housing back in unit (except on models LT) and put stainless steel load tray back on elevator housings. Load unit to test dispensing level. If spring adjustment does not position carrier properly, repeat procedure #6 trying different springs. If this does not work, a different set of springs may be required. To order, call The Delfield Parts and Service Department.
8. If level is appropriate, put front panels back on and tighten retainer.



Dispenser should not be operated with front panels off elevator housing.

NOTE: When adjusting the elevators make sure each have the same number and size of springs connected to the carrier on both sides. This will prevent the load tray from binding.

Adjusting Self-Leveling Dispensers, Model CT



**Tools Needed: One small flat head screw driver;
One Phillips head screw driver**

1. Always wear safety glasses when adjusting your dispenser. Also, lock brakes on mobile units before beginning.
2. Unload dispenser.
3. Use screw driver to remove two screws, one on each side of the elevator housing.
4. Remove cover and slide front panel off.

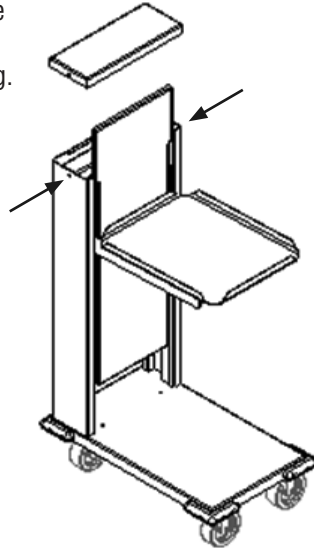

5. If carrier is riding too high, you need to remove springs. With carrier all the way to the top, gently disengage one spring at a time, unhooking bottom loop out of carrier bracket. Remove as many springs as necessary.

If carrier is riding too low, you need to add springs. With carrier all the way to the top, gently engage one spring at a time by hooking bottom loop of spring into carrier bracket. Add as many springs as necessary.

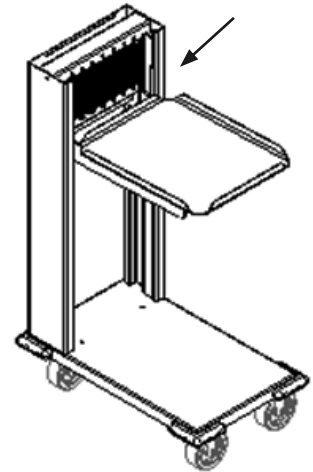

6. Load unit to test dispensing level. If spring adjustment does not position carrier properly, repeat step #5 trying different springs. If this does not work, a different set of springs may be required. To order, call The Delfield Parts and Service Department.
7. If level is appropriate, replace front panel and cover. Secure with screws.



Dispenser should not be operated with front panel off elevator housing.

Maintenance

Dish Dispensers



Heated units must be disconnected from the main power source and allowed to cool down before cleaning. Cords on DIS models used as drop-ins into a counter or into another piece of equipment are directly connected to the power source. On CAB units there is a cord from each individual DIS tube to a central receptacle on the cart and a separate cord from that receptacle to the main power source. Never hose down units with water.

Lift the dispenser out of the counter or CAB cart by grasping the black dish guides and lifting straight up and out. Remove any debris that may be in the assembly with a damp cloth. Clean the stainless steel by using a soft cloth, soap and warm water. If this is not sufficient, try ammonia and water or a non-abrasive liquid cleaner. Rub with the grain of the stainless steel to avoid marring the finish. When cleaning is completed, insert the dispenser assembly back into the counter or CAB cart.

The bottom rails on the CAB cart should be cleaned occasionally. They may be accessed most easily through the bottom of the unit.



Do not use abrasive cleaner because it will scratch the stainless steel and plastic.

NOTE:

Mobile & Built In Dispensers

The interior and exterior can be cleaned using soap and warm water. If this is not sufficient, try ammonia and water or a non-abrasive liquid cleaner. When cleaning the exterior, always rub with the “grain” of the stainless steel to avoid marring the finish. Do not use an abrasive cleaner because it will scratch the stainless steel and plastic.

Troubleshooting Reference Chart: Heated Dish Dispensers

<i>Problem</i>	<i>Possible Cause</i>	<i>Solutions</i>
No Heat	Power cord disconnected	Check power source to unit and receptacle at the underside of the cabinet. Reset GFCI receptacle position
	GFCI tripped	
	Disconnected ON/OFF switch or ON/OFF switch in the OFF position	Replace ON/OFF switch; turn ON/OFF switch to on position
	Defective heating element	Replace element
	Air circulating fan defective or blocked	Replace motor, or remove blockage from fan
Not Hot Enough	Unit plugged into incorrect voltage	Check voltage supply and compare to unit's voltage rating
	Thermostat set too low	Adjust thermostat to a higher setting
	Air circulating fan partially blocked	Remove blockage
	Not waiting long enough for pre-heating	90 minutes is a good average pre-heat on DIS models
Too Hot	Thermostat set too high	Adjust thermostat to a lower setting
	Thermostat defective	Replace thermostat
Noisy	Defective air circulating motor	Replace motor
	Obstruction at air circulating motor	Free obstruction
	Loose fan blade	Tighten blade

Wiring Diagram: DIS Models & T-H Models

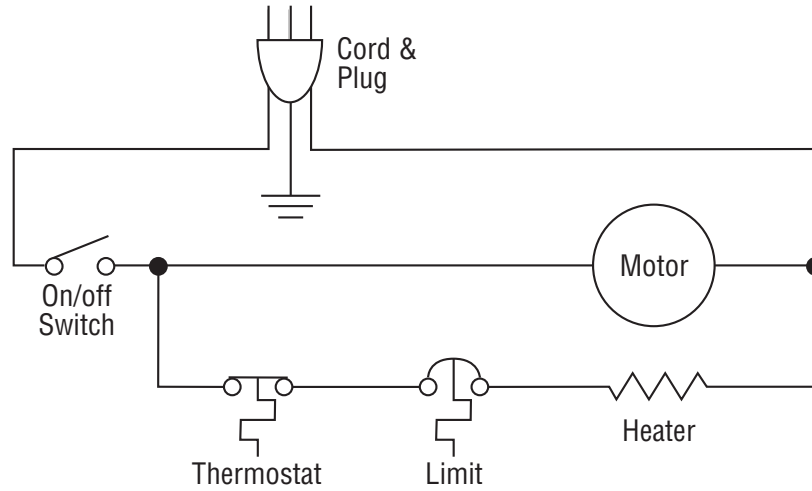

Wiring Diagram: CAB Models

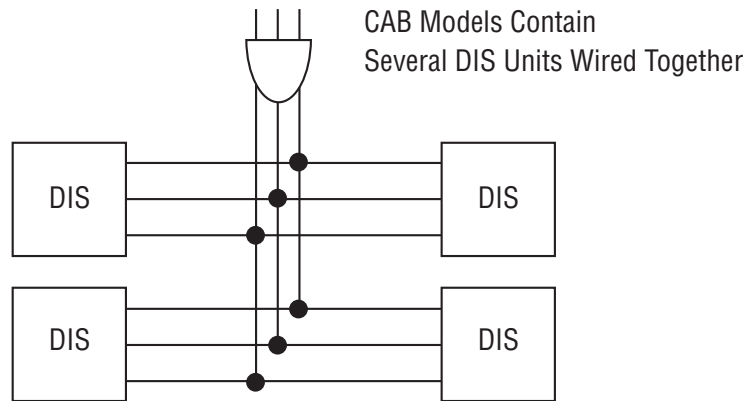

Replacement Parts List

Models DIS

All units

6230314	Filter, air, 6" diameter (DDS)
6230244	Guide post
6150201	Spring, heavy tension
6150203	Spring, light tension
6150202	Spring, medium tension

500 units

6200121	Spinning head
6970011	Wire head

575 units

6200122	Spinning head
6970012	Wire head

650 units

6200123	Spinning head
6970013	Wire head

725 units

6200124	Spinning head
6970014	Wire head

813 units

6200125	Spinning head
6970015	Wire head

913 units

6200126	Spinning head
6970016	Wire head

1013 units

6200127	Spinning head
6970017	Wire head

1200 units

6200128	Spinning head
6970018	Wire head

1450 units

6200129	Spinning head
6970026	Wire head

Model DIS-ET, DIS-QT

All units

6190085	Cord with plug, NEMA 5-15P 5'
6230314	Filter, air, 6" diameter
6230244	Guide post
6160024	Motor, 115V 50-60Hz
6150201	Spring, heavy tension
6150203	Spring, light tension
6150202	Spring, medium tension
6190180	Switch, high-limit, 245°F
2190154	Switch rocker
6190181	T-stat, automatic 165°F - 205°F

500/ 575/ 650/ 725 ET units

6160008	Fan blade, 3" diameter
6190250	Heating element, 120V/327W
000-BHM-0030	Heating module

813/ 913/ 1013/ 1200/ 1450 ET & QT units

6160007	Fan blade, 4" dia, ET & QT
6190269	Htg element, 120V/700W, ET & QT
000-BHM-0031	Heating module, ET & QT models

Model CAB, CAB-ET, CAB-QT

All units

3234180	Caster, 4" with brake
6190085	Cord with plug, NEMA 5-15P 5'
6230314	Filter, air, 6" diameter
6230244	Guide post
6160024	Motor, 115V 50-60Hz
6150203	Spring, light tension
6150202	Spring, medium tension
6190180	Switch, high-limit, 245°F
2190154	Switch rocker
6190181	T-stat, automatic 165°F - 205°F

500/ 575/ 650/ 725 ET units

6160008	Fan blade, 3" diameter
6190250	Heating element, 120V/327W
000-BHM-0030	Heating module

813/ 913/ 1013/ 1200/ 1450 ET & QT units

6160007	Fan blade, 4" dia, ET & QT models
6190269	Htg element, 120V/700W, ET & QT
000-BHM-0031	Heating module, ET & QT models

CAB2-ET & CAB2-QT units

2183347	Cord with plug, NEMA 5-20P 9'
---------	-------------------------------

CAB3-ET, CAB4-ET, CAB3-QT, CAB4-QT units

6190079	Cord with plug, NEMA 6-20P 9'
---------	-------------------------------

Model SB

6150024	Dish spring
---------	-------------

Model ND

ND-45

223-BGA-0030	Cover
6150203	Extension spring
313-B38-0030	Head

ND-47

223-BGA-0031	Cover
6150203	Extension spring
313-B38-0031	Head

ND-48

223-BGA-0032	Cover
6150203	Extension spring
313-B38-0032	Head

ND-57

223-BGA-0033	Cover
6150203	Extension spring
313-B38-0033	Head

ND-59

223-BGA-0034	Cover
6150203	Extension spring
313-B38-0034	Head

ND-67

223-BGA-0035	Cover
6150203	Extension spring
313-B38-0035	Head



Replacement Parts List, *continued*

Model CT Series

6230068	Bearing
6230170	Bumper, corner, small
3234180	Caster, 4"
6150206	Extension spring

CT-1216

000-BLD-0030	Carrier assembly, 12.50 x 16.50
--------------	---------------------------------

CT-1221

000-BLD-0031	Carrier assembly, 12.50 x 21.50
--------------	---------------------------------

CT-1418

000-BLD-0032	Carrier assembly, 14.56 x 18.56
--------------	---------------------------------

CT-1422

000-BLD-0033	Carrier assembly, 14.50 x 22.50
--------------	---------------------------------

CT-1622

000-BLD-0034	Carrier assembly, 16.56 x 22.56
--------------	---------------------------------

CT-1826

000-BLD-0035	Carrier 18.56 x 26.56
--------------	-----------------------

CT-2020

000-BLD-0036	Carrier assembly, 20.56 x 21.56
--------------	---------------------------------

Model FT2-SN All units

6320007	Bearing
6230218	Caster, 4"
6230170	Corner bumper
000-546-0038	Elevator assembly, large
6150203	Extension spring .16
6150202	Extension spring .28
6150201	Extension spring .58
6230024	Silverware container, Plastic
3234052	Silverware container, S/S

FT2-SN-1216

372-395-0030	Carrier 1216
--------------	--------------

FT2-SN-1418

372-395-0032	Carrier, 1418
--------------	---------------

FT2-SN-1622

372-395-0035	Carrier 1622
--------------	--------------

Model T & T2 Series

T-1014, All T2 Models

6320007	Bearing, 0.50"ID
3234180	Caster, 4", Swivel, with Break
6150201	Spring, Extension, 0.58lbs/in

T-1216 through T-2020

6320007	Bearing, 0.50"ID
3234180	Caster, 4", Swivel, with Break
6150202	Spring, Extension, 0.28lbs/in

Model LT & LT2 Series

LT-1014, All LT2 Models

6320007	Bearing, 0.50"ID
6150201	Spring, Extension, 0.58lbs/in

LT-1216 through LT-2020

6320007	Bearing, 0.50"ID
6150202	Spring, Extension, 0.28lbs/in

Model T-H & T2-H Series

All Models

6320007	Bearing, 0.50"ID
6160007	Blade, Fan 4"Dia, Alum
3234180	Caster, 4", Plate, Swivel, Break
6190269	Element, Heating, 120V/700W
6160024	Motor, 115V, 50/60Hz
6190180	Switch, Hi-limit, 245F
2190154	Switch, Rocker, 20A/125V, 15A/250V
6190181	Thermostat

T-1221H, T-1418H

2183348	Cord Assembly, 14/3 W/Nema 5-15P
---------	----------------------------------

T-1422H, T-1826H, T-2020H, T2-1221H

2183347	Cord Assembly, 12/3 W/Nema 5-20P
---------	----------------------------------

All T-H Models

6150202	Spring, Extension, 0.28lbs/in
---------	-------------------------------

T2-1221H

6150201	Spring, Extension, 0.58lbs/in
---------	-------------------------------

Model TT Series

All Models

6320007	Bearing, 0.50"ID
6230218	Caster, 4", Stem, Swivel Break
6150201	Spring, Extension, 0.58lbs/in

Standard Labor Guidelines To Repair Or Replace Parts On Delfield Equipment

Advice and recommendations given by Delfield Service Technicians do not constitute or guarantee any special coverage.

- A maximum of 1-hour is allowed to **diagnose a defective component**.
- A maximum of 1-hour is allowed for **retrieval of parts** not in stock.
- A maximum **travel distance** of 100 miles round trip and 2-hours will be reimbursed.
- Overtime, installation/start-up, normal control adjustments, general maintenance, glass breakage, freight damage, and/or correcting and end-user installation error will not be reimbursed under warranty unless pre-approved with a **Service Work Authorization** from Delfield. You must submit the number with the service claim.

LABOR OF 1-HOUR IS ALLOWED TO REPLACE:

- Thermostat
- Transformer
- Circulating Fan Motor and Blade
- Hi-limit/Thermal Protector Switch
- Springs/Lowerator

LABOR OF 2 HOURS TO REPLACE:

- Heating Element



Mt. Pleasant, MI



Covington, TN

Thank you for choosing Delfield!

Help is a phone call away. Help our team of professional, courteous customer service reps by having your model number and serial number available at the time of your call (800) 733-8829.

Model: _____ S/N: _____

Installation Date: _____



For a list of Delfield's authorized parts depots, visit our website at www.delfield.com

Register your Delfield warranty online. Go to www.delfield.com under the service tab to complete.

