



Chili's

Service and Installation Manual

Please read this manual completely before attempting to install or operate this equipment! Notify carrier of damage! Inspect all components immediately. See page 2.



 **Important Information**
Read Before Use
Please Save These Instructions!

June 2012



Contents

| | |
|--------------------------------|-------|
| Serial Number Location | 2 |
| Receiving And Inspecting | 2 |
| Specifications..... | 3 |
| Wiring Diagram..... | 3 |
| Installation | 4 |
| Operation | 4 |
| Cold Rail Timer Setup | 5 |
| Pressure Control Settings..... | 5 |
| Preventive Maintenance | 6-7 |
| Replacement Parts..... | 8-12 |
| Standard Labor Guidelines..... | 13 |
| Warranties..... | 14-15 |

Serial Number Location

The serial number is located in the interior back top corner.

Always have the serial number of your unit available when calling for parts or service. A complete list of authorized Delfield parts depots is available at www.delfield.com

©2012 The Delfield Company. All rights reserved. Reproduction without written permission is prohibited. "Delfield" is a registered trademark of The Delfield Company.

Receiving And Inspecting The Equipment

Even though most equipment is shipped crated, care should be taken during unloading so the equipment is not damaged while being moved into the building.

1. Visually inspect the exterior of the package on skid or container. Any damage should be noted and reported to the delivering carrier immediately.
2. If damaged, open and inspect the contents with the carrier.
3. In the event that the exterior is not damaged, yet upon opening, there is concealed damage to the equipment notify the carrier. Notification should be made verbally as well as in written form.
4. Request an inspection of the concealed equipment. This should be done within 10 days from receipt of the equipment.
5. Check the lower portion of the unit to be sure casters are not bent.
6. Also remove the back and visually inspect the refrigeration

- package. Be sure lines are secure and base is still intact.
7. Freight carriers can supply the necessary forms upon request.
8. Retain all crating material until an inspection has been made or waived.

Uncrating the Equipment

First cut and remove the banding from around the crate. Remove the front of the crate material, use of some tools will be required.

Specifications

| SKU # | Model # | # of Doors | Volume Cu.Ft. | Shelf Area Sq. Ft. | HP | Volts/Hertz/Phase | Amps | BTU Load (Base) | BTU Load (Rail) | Refg. 404a Charge (oz.) |
|------------------------------|------------|------------|---------------|--------------------|-----|-------------------|------|-----------------|-----------------|-------------------------|
| DCH-BLS-32R | F18MC32-BI | 1 | 7.7 | 5.32 | 1/3 | 115/60/1 | 8.0 | 424 | 1058 | 24.0 |
| DCH-BLSN-33L DCH-BLSN-33R | F18MC33-BI | 1 | 7.7 | 5.32 | 1/3 | 115/60/1 | 8.0 | 424 | 1058 | 24.0 |
| DCH-BS-27L DCH-BS-27R | F18MC27-BI | 1 | 6.3 | 4.36 | 1/3 | 115/60/1 | 8.0 | 424 | 1058 | 24.0 |
| DCH-BS-32L | F18MC32-BI | 1 | 7.7 | 5.32 | 1/3 | 115/60/1 | 8.0 | 424 | 1058 | 24.0 |
| DCH-BSN-27L DCH-BSN-27R | F18MC27-BI | 1 | 6.3 | 4.36 | 1/3 | 115/60/1 | 8.0 | 424 | 1058 | 24.0 |
| DCH-BSN-32L DCH-BSN-32R | F18MC32-BI | 1 | 7.7 | 5.32 | 1/3 | 115/60/1 | 8.0 | 424 | 1058 | 24.0 |
| DCH-DC-27L DCH-DC-27R | F18MC27-BI | 1 | 6.3 | 4.36 | 1/3 | 115/60/1 | 8.0 | 424 | 1058 | 24.0 |
| DCH-FS-27L DCH-FS-27R | F18MC27-BI | 1 | 6.3 | 4.36 | 1/3 | 115/60/1 | 8.0 | 424 | 1058 | 24.0 |
| DCH-FS-32L DCH-FS-32R | F18MC32-BI | 1 | 7.7 | 5.32 | 1/3 | 115/60/1 | 8.0 | 424 | 1058 | 24.0 |
| DCH-FSN-27L DCH-FSN-27R | F18MC27-BI | 1 | 6.3 | 4.36 | 1/3 | 115/60/1 | 8.0 | 424 | 1058 | 24.0 |
| DCH-FSN-27DRW | F18MC27-BI | 2 Drawers | 6.3 | NA | 1/3 | 115/60/1 | 8.0 | 424 | 1058 | 24.0 |
| DCH-FSN-33L DCH-FSN-33R | F18MC33-BI | 1 | 7.7 | 5.32 | 1/3 | 115/60/1 | 8.0 | 424 | 1058 | 24.0 |
| DCH-SCS-33L DCH-SCS-33R | F18MC33-BI | 1 | 7.7 | 5.32 | 1/3 | 115/60/1 | 8.0 | 424 | 1058 | 24.0 |

Wiring Diagram

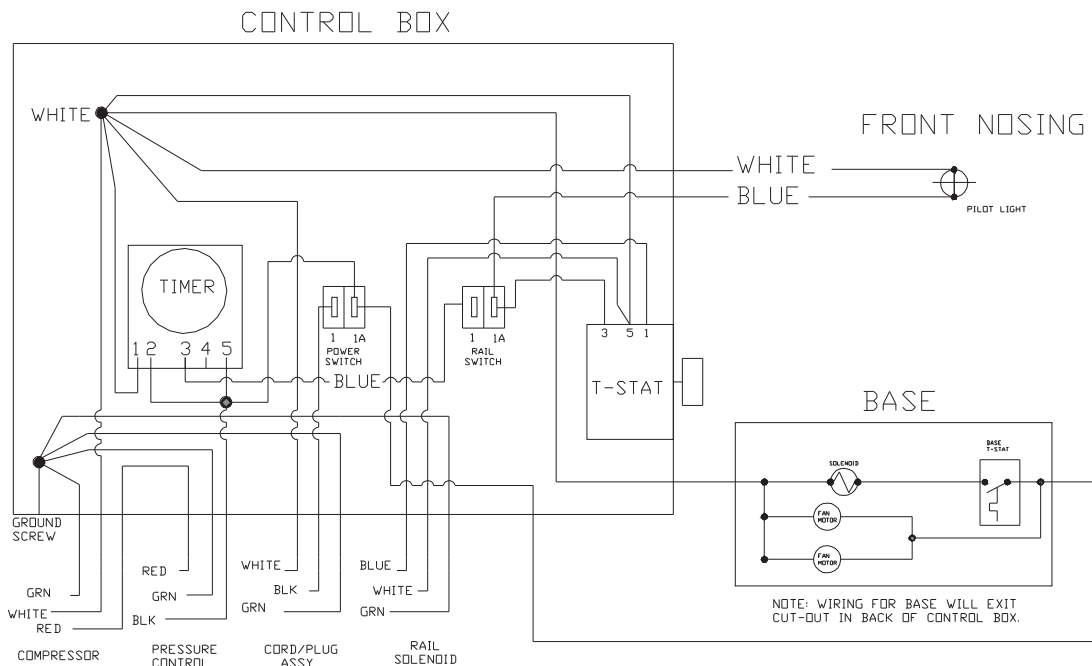

Installation

Location

Be sure the location chosen has a floor strong enough to support the total weight of the cabinet and contents. A fully loaded model may weigh as much as 500 pounds! Reinforce the floor as necessary to provide for maximum loading.

It is very important to allow for proper air flow, both inside and outside.

Avoid hot corners and locations near stoves, ovens and other pieces of cooking equipment.



NOTE:

It is recommended that the unit be installed no closer than 1" from any wall. Do not install the unit near any combustible material or object affected by heat or moisture.

Leveling

A level cabinet looks better and will perform better because the drain pan will drain properly, the doors will line up with the frames properly, and the cabinet will not be subject to undue strain.

A unit on casters will not be adjustable. Be sure the unit is on a level floor, make necessary changes to the floor for proper level.

Plumbing

Self-contained models are standard with a condensate evaporator. If, for some reason a unit does not have a condensate evaporator, or if the evaporator fails, the unit's drain must have an outlet to an appropriate drainage area or container.



CAUTION

Moisture collecting from improper drainage can create a slippery surface on the floor and a hazard to employees. It is the owner's and operator's responsibility to provide a container or outlet for drainage.

Electrical connection

Refer to the amperage data on pages 3, the serial tag, your local code or the National Electrical Code to be sure the unit is connected to the proper power source. A protected circuit of the correct voltage and amperage must be run for connection of the line cord, or permanent connection of the unit.

Self-contained units with a cord and plug have an **ON/OFF** switch located on the back of the equipment. Simply turn the switch to **ON** to begin operation.



DANGER

The power switch must be turned to OFF and the unit disconnected from the power source whenever performing service or maintenance functions.

Never operate the unit without the louvered panel in place!

Operation

After turning the **ON/OFF** switch to **ON** the unit's compressor will begin operating. Delfield refrigerated bases are designed to maintain an operational temperature of 36°F to 40°F. Temperature in the salad top and refrigerated rail opening is 33°F to 41°F.



NOTE:

Do not place hot pans on/against the blue ABS liner. Do not throw items into the storage area. Failure to heed these recommendations could result in damage to the interior of the cabinet or to the blower coil.



NOTE:

Overloading the storage area, restricting the air flow, and continuous opening and closing of the doors will hamper the units ability to maintain operational temperature.

Refrigerated rail units

To ensure product quality in the rail it is recommended that product be rotated every four hours. Product in the rail must be removed and stored in the refrigerated base at the end of

the day. When the timer is set, the rail will turn off at night and on again in the morning. This will save energy, allow the rail time to defrost and maintain product quality. The LiquiTec rail is required to be shut off at night, there is a rail ON/OFF switch to be used if necessary. A pilot light on front of the unit will illuminate when the rail is on. With a LiquiTec rail a thermostat is provided to maintain rail temperature. To adjust for colder temperatures, turn the knob clockwise. For warmer temperatures, turn the knob counter-clockwise. Never turn the knob more than 1 dial number and always allow 8 hours for temperature stabilization before making additional adjustments.



CAUTION

The rail cover must not be removed during rail operation. Any attempt to modify the rail could result in operator injury.



DANGER

If adding any item to the unit, be sure to keep in mind the location of the refrigeration lines on wrapped rail units. A refrigeration leak in a rail is extremely difficult and costly to repair. In some cases it cannot be repaired at all.

Cold Rail Timer Setup

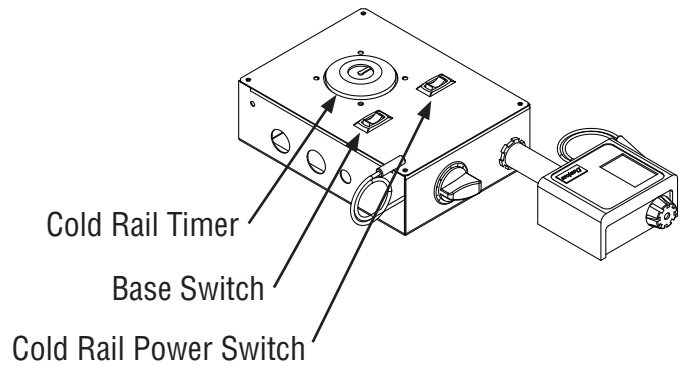
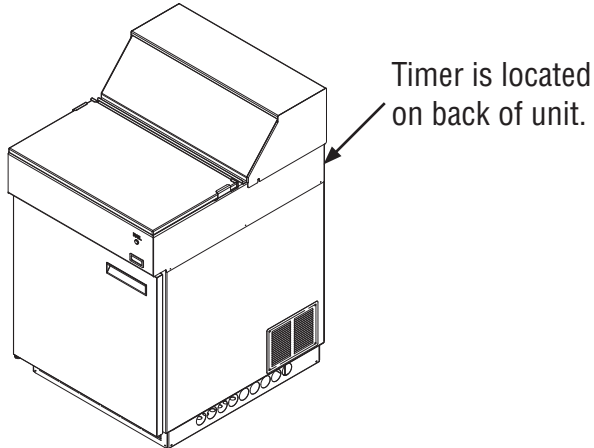

After installing the unit, find the timer located on back of the unit. See graphic above. Set the Cold Rail timer to the correct local time. Turn the rail switch ON. The defrost period is factory set to standard Brinker International specifications (OFF at 12:00 a.m., ON at 8:30 a.m.). A pilot light on front of the unit will illuminate when the rail is on.

Remove any water remaining in the cold rail during early morning operations. Cold rails should be cleaned at this time when the frost/ice is not present. Rail performance will be significantly reduced if water remains in rail and is allowed to freeze.



NOTE: High ambient temperature, humidity, or a rail that does not have a full compliment of pans can cause excessive frost in the rail.



NOTE: If there is excessive frost upon morning startup, call Delfield customer service.

Pressure Control Settings

Factory recommended low-pressure control settings are:

HFC-404A refrigerators with LiquiTec Rail:

20# cut-in and 10# cut-out to

Differential setting of 10#



NOTE: Pressure control settings are measured in pounds, not fahrenheit.

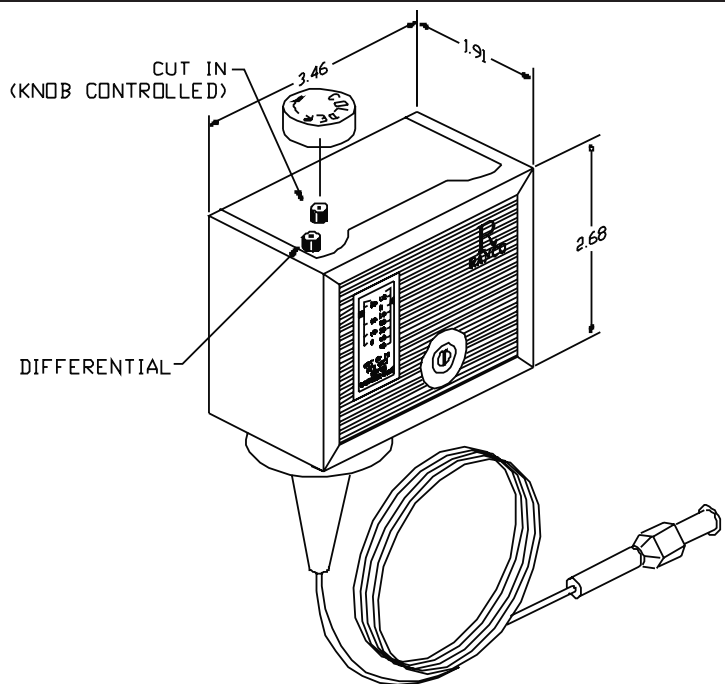

Preventive Maintenance

Door Gasket Maintenance

Door gaskets require regular cleaning to prevent mold and mildew build up and also to retain the elasticity of the gasket. Gasket cleaning can be done with the use of warm soapy water. Avoid full strength cleaning products on gaskets as this can cause them to become brittle and crack. Never use sharp tools or knives to scrape or clean the gasket. Gaskets can be easily replaced and do not require the use of tools or an authorized service person. The gaskets are "Dart" style and can be pulled out of the groove in the door and new gaskets can be "pressed" back into place.

Drain Maintenance - Base

Each unit has a drain located inside the unit that removes the condensation from the evaporator coil and routes it to an external condensate evaporator pan. Each drain can become loose or disconnected during normal use. If you notice water accumulation on the inside of the unit be sure the drain tube is connected to the evaporator drain pan. If water is collecting underneath the unit make sure the end of the drain tube is in the condensate evaporator in the machine compartment. The leveling of the unit is important as the units are designed to drain properly when level. Be sure all drain lines are free of obstructions.

Drawer Maintenance

Drawer Assembly Cleaning

The drawer assembly is designed to be cleaned easily. Both drawer and tracks are removable without tools. The drawer tracks are dishwasher safe or can be cleaned in a sink with detergents and a soft bristle brush. Drawers and tracks should be cleaned on a weekly basis.

Remove Drawers

Pull the drawer box out until it stops. Lift up on the drawer front and pull the drawer box completely out. Using a soft bristle brush, clean the track on the bottom of the drawer box. When finished, it should be wiped clean of all food and debris.

Tracks

The drawer box assembly must be removed. Pull the drawer tracks out until they hit a stop. Locate blue safety clips towards the back of each drawer track.

Blue safety clips have a tab on the top. Push the tab back until it clicks. Lift up and pull the drawer tracks all the way

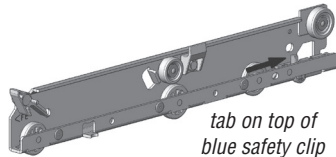

out of the drawer cage. The drawer tracks are dishwasher safe or can be cleaned in a sink with detergents and a soft bristle brush. Drawers and tracks should be cleaned on a weekly basis. Using a soft bristle brush, wash the track making sure each roller is thoroughly cleaned. The drawer cage should be cleaned with a soft bristle brush, removing any food and debris gathered on the bottom ledge. Once it's cleaned thoroughly with a soft bristle brush, wipe remaining debris clean with a soft towel.

Reassembly

Push the drawer tracks into the drawer cage. The blue safety clip must remain pushed towards the back. Lift up and slide the drawer track all the way into the drawer cage. The blue safety clip will lock in place automatically. Once all tracks are replaced, insert the drawer box. Rest the drawer box bottom track on the front track roller. Then push the drawer back in place SLOWLY. When the drawer box is about half way in you will hit a STOP. You must lift the front of the drawer up approximately 1/2" (1.3cm) to continue inward. Clean tracks as often as possible. The cleaner the tracks are the better they will operate.

Caster Maintenance

Wipe casters with a damp cloth monthly to prevent corrosion.



The power switch must be turned to OFF and the unit disconnected from the power source whenever performing service, maintenance or cleaning the refrigerated area.

Refrigerators

The interior and exterior can be cleaned using soap and warm water. If this isn't sufficient, try ammonia and water or a nonabrasive liquid cleaner. When cleaning the exterior, always rub with the "grain" of the stainless steel to avoid marring the finish. Do not use an abrasive cleaner because it will scratch the stainless steel and can damage the breaker strips and gaskets.

Stainless Steel Care and Cleaning

To prevent discoloration or rust on stainless steel several important steps need to be taken. First, we need to understand the properties of stainless steel. Stainless steel contains 70-80% iron, which will rust. It also contains 12-30% chromium, which forms an invisible passive film over the steel's surface, which acts as a shield against corrosion. As long as the protective layer is intact, the metal is still stainless. If the film is broken or contaminated, outside elements can begin to breakdown the steel and begin to form discoloration or rust. Proper cleaning of stainless steel requires soft cloths or plastic scouring pads.

NEVER USE STEEL PADS, WIRE BRUSHES OR SCRAPERS!

Cleaning solutions need to be alkaline based or non-chloride cleaners. Any cleaner containing chlorides will damage the protective film of the stainless steel. Chlorides are also commonly found in hard water, salts, and household and industrial cleaners. If cleaners containing chlorides are used be sure to rinse repeatedly and dry thoroughly. Routine cleaning of stainless steel can be done with soap and water. Extreme stains or grease should be cleaned with a non-abrasive cleaner and plastic scrub pad. Always rub with the grain of the steel. There are stainless steel cleaners available which can restore and preserve the finish of the steels protective layer. Early signs

Preventive Maintenance, continued

of stainless steel breakdown are small pits and cracks. If this has begun, clean thoroughly and start to apply stainless steel cleaners in attempt to restore the passivity of the steel.



Never use an acid based cleaning solution! Many food products have an acidic content, which can deteriorate the finish. Be sure to clean the stainless steel surfaces of ALL food products. Common items include, tomatoes, peppers and other vegetables.

Cleaning the Condenser Coil

In order to maintain proper refrigeration performance, the condenser fins must be cleaned of dust, dirt and grease regularly. It is recommended that this be done at least every three months. If conditions are such that the condenser is totally blocked in three months, the frequency of cleaning should be increased. Clean the condenser with a vacuum cleaner or stiff brush. If extremely dirty, a commercially available condenser cleaner may be required.

Failure to maintain a clean condenser coil can initially cause high temperatures and excessive run times. Continuous operation with a dirty or clogged condenser coil can result in compressor failure. Neglecting the condenser coil cleaning procedures will void any warranties associated with the compressor and cost to replace the compressor.



Never use a high-pressure water wash for this cleaning procedure as water can damage the electrical components located near or at the condenser coil.

Doors/Hinges

Over time and with heavy use doors the hinges may become loose. If this happens tighten the screws that mount the hinge brackets to the frame of the unit. Loose or sagging doors can cause the hinges to pull out of the frame, which may damage both the doors and the hinges. In some cases this may require qualified service agents or maintenance personnel to perform repairs.



Do not place hot pans on/against the blue ABS liner. Do not throw items into the storage area. Failure to follow these recommendations could result in damage to the interior of the cabinet or to the blower coil. Overloading the storage area, restricting the airflow, and continuous opening and closing of the doors and drawers will hamper the units ability to maintain operational temperature.

Refrigerated rail units

Product in the rail should be removed to the refrigerated base at the end of the day. This allows you to turn the rail off at night to save energy and to defrost the rail. It also helps maintain

product quality. The standard wrapped refrigerated rail units are controlled by a low-pressure control that is set to maintain the proper rail temperature. An on/off switch is also provided for the rail and is required to be shut off at night. With a LiquiTec rail a thermostat is provided to maintain rail temperature as well as the rail on/off switch. The LiquiTec rail is required to be shut off at night as well to allow for defrosting. To ensure product quality in the rail it is recommended that product be rotated every four hours.



If adding any item to the unit, be sure to keep in mind the location of the refrigeration lines on wrapped rail units. A refrigeration leak in a rail is extremely difficult and costly to repair. In some cases it cannot be repaired at all.

Preventing blower coil corrosion

To help prevent corrosion of the blower coil, store all acidic items, such as pickles and tomatoes, in sealable containers. Immediately wipe up all spills.



Units with pans should be operated with pans in place. Operating the unit without all pans in place will lower efficiency and may damage the unit.

Continuous opening and closing of the doors will hamper the unit's ability to maintain optimum refrigeration temperature. Top section is not intended for overnight storage. Product should be removed from pans. Pans can remain in unit while empty.

Defrosting

Refrigerated cold pans should be defrosted daily.

Never use sharp objects or tools to clean or scrape ice/frost build up from the refrigerated cold pans. A puncture to the pan could cause irreparable damage to the refrigeration system.

Units with a Eutectic Fluid Cold Pan require the same precautions. The fluid is NOT refillable and loss of fluid due to a puncture would cause irreparable damage.

Over shelves and other items mounted to the top of the counters should never be installed in the field due to the potential damage to the refrigeration system.

Replacement Parts

All 27" Models

| | |
|---------------|--|
| 3234147 | Caster, 2", plate, swivel |
| 3516103 | Coil, Solenoid (base) |
| 3516053 | Coil, Solenoid, 120V/50 (rail) |
| *000-BDJ-0032 | Condensing Unit Assembly |
| 2193927 | Control, Pressure, Low |
| BCB-8-27 | Cutting Board Assembly, 27" x 8" |
| *270-BEU-0036 | Divider, I-Bar Adapter, 2.93 |
| 000-248-0016 | Evaporator coil assembly |
| 2194190 | Light, Pilot, 125V, Red |
| *359-411-0039 | Louver, Left |
| *359-411-003A | Louver, Right |
| 9321137 | Screw, shoulder (for heat shield) |
| 2190154 | Switch, Rocker, 20A/125V |
| 3516133 | Thermometer, Dial |
| 2194536 | Thermostat (base) |
| 000-282-0051 | Thermostat, Danfoss (rail) |
| 2194345 | Timer, 24 HR, Clock Face |
| 3516394 | Valve, Expansion, R-404a, 1/8 ton (base) |
| 3516225 | Valve, Exp, Frz, 1/4Ton (rail) |
| 3516102 | Valve, Solenoid, 1/4ODF (base & rail) |

* Part print on pages 11-12.

DCH-DC-27L / DCH-DC-27R

| | |
|---------------|-------------------------------|
| 104-004-0036 | Board, cutting, white poly |
| *263-110-0035 | Bracket, cutting board, left |
| *263-110-0037 | Bracket, cutting board, right |
| *000-B2G-004A | Cover, 27" single |

DCH-FS-27L / DCH-FS-27R

DCH-BS-27L / DCH-BS-27R

| | |
|---------------|-------------------|
| *000-B2G-0035 | Cover, 27" double |
|---------------|-------------------|

DCH-FSN-27L / DCH-FSN-27R

| | |
|---------------|-------------------------|
| *000-B2G-004D | Cover, 27" double, tall |
|---------------|-------------------------|

DCH-FSN-27DRW

| | |
|---------------|-----------------------------------|
| 104-004-003J | Board, cutting, 8 x 27 |
| *263-110-003D | Bracket, cutting board, 8", left |
| *263-110-003C | Bracket, cutting board, 8", right |
| *000-B2G-004D | Cover, 27" double, tall |
| *000-AEW-007Z | Drawer Sys Assembly, 27 2-Hi |

DCH-DC-27L / DCH-DC-27R

DCH-FS-27L / DCH-FS-27R

DCH-FSN-27L / DCH-FSN-27R

| | |
|--------------|----------------------------------|
| 000-187-0082 | Door Assembly, Ref, 27X26, Left |
| 000-187-0081 | Door Assembly, Ref, 27X26, Right |
| 1701185 | Gasket, door |
| 0160179 | Hinge Kit (right or left) |
| 9321132 | Screw, shelf support |
| BIP00002 | Shelf, Wire, 27", 22.62 X 13.88 |
| 3234290 | Support, Shelf, Plastic, Blue |

DCH-BSN-27L / DCH-BSN-27R

| | |
|---------------|----------------------------------|
| *000-B2G-004D | Cover, 27" double, tall |
| 000-187-0082 | Door Assembly, Ref, 27X26, Left |
| 000-187-0081 | Door Assembly, Ref, 27X26, Right |
| 1701185 | Gasket, door |
| 0160179 | Hinge Kit (right or left) |
| 9321132 | Screw, shelf support |
| BIP00002 | Shelf, Wire, 27", 22.62 X 13.88 |
| 3234290 | Support, Shelf, Plastic, Blue |

Replacement Parts

All 32" Models

| | |
|---------------|--|
| 3234147 | Caster, 2", plate, swivel |
| 3516103 | Coil, Solenoid (base) |
| 3516053 | Coil, Solenoid, 120V/50 (rail) |
| *000-BDJ-0032 | Condensing Unit Assembly |
| 2193927 | Control, Pressure, Low |
| BCB-8-32 | Cutting Board Assembly, 32" x 8" |
| *270-BEU-0036 | Divider, I-Bar Adapter, 2.93 |
| 000-187-0084 | Door Assembly, Ref, 32X26, Left |
| 000-187-0083 | Door Assembly, REF,32X26, Right |
| 000-248-0016 | Evaporator coil assembly |
| 1701186 | Gasket, door |
| 0160179 | Hinge Kit (right or left) |
| 2194190 | Light, Pilot, 125V, Red |
| *359-411-0039 | Louver, Left |
| *359-411-003A | Louver, Right |
| 9321132 | Screw, shelf support |
| 9321137 | Screw, shoulder (for cover) |
| BIP00001 | Shelf, Wire, 32", 27.62 X 13.88 |
| 3234290 | Support, Shelf, Plastic, Blue |
| 2190154 | Switch, Rocker, 20A/125V |
| 3516133 | Thermometer, Dial |
| 2194536 | Thermostat (base) |
| 000-282-0051 | Thermostat, Danfoss (rail) |
| 2194345 | Timer, 24 HR, Clock Face |
| 3516394 | Valve, Expansion, R-404a, 1/8 ton (base) |
| 3516102 | Valve, Solenoid (base & rail) |
| 3516225 | Valve, Exp, Frz, 1/4Ton (rail) |

DCH-BSN-32L / DCH-BSN-32R

| | |
|---------------|-------------------------|
| *000-B2G-004C | Cover, 32" double, tall |
|---------------|-------------------------|

DCH-FS-32R / DCH-FS-32L

| | |
|---------------|------------------------------|
| 104-004-003C | Board, poly, 32 X 6 |
| *000-B2G-0036 | Cover, 32" double |
| 263-110-003B | Cutting board bracket, left |
| 263-110-003A | Cutting board bracket, right |

* Part print on pages 11-12.

Replacement Parts

All 33" Models

| | |
|---------------|--|
| 3234147 | Caster, 2", plate, swivel |
| 3516103 | Coil, Solenoid (base) |
| 3516053 | Coil, Solenoid, 120V/50 (rail) |
| *000-BDJ-0032 | Condensing Unit Assembly |
| 2193927 | Control, Pressure, Low |
| BCB-8-33 | Cutting Board Assembly, 33" x 8" |
| 000-187-0084 | Door Assembly, Ref, 32X26, Left |
| 000-187-0083 | Door Assembly, Ref, 32X26, Right |
| 000-248-0016 | Evaporator coil assembly |
| 1701186 | Gasket, door |
| 0160179 | Hinge Kit (right or left) |
| 2194190 | Light, Pilot, 125V, Red |
| *359-411-0039 | Louver, Left |
| *359-411-003A | Louver, Right |
| 9321132 | Screw, shelf support |
| BIP00001 | Shelf, Wire, 32", 27.62 X 13.88 |
| 3234290 | Support, Shelf, Plastic, Blue |
| 2190154 | Switch, Rocker, 20A/125V |
| 3516133 | Thermometer, Dial |
| 2194536 | Thermostat (base) |
| 000-282-0051 | Thermostat, Danfoss (rail) |
| 2194345 | Timer, 24 HR, Clock Face |
| 3516394 | Valve, Expansion, R-404a, 1/8 ton (base) |
| 3516102 | Valve, Solenoid (base & rail) |
| 3516225 | Valve, Exp, Frz, 1/4Ton (rail) |

DCH-FSN-33L / DCH-FSN-33R

| | |
|---------------|------------------------------|
| *000-B2G-004B | Cover, 33" double, tall |
| *270-BEU-0036 | Divider, I-Bar Adapter, 2.93 |
| 9321137 | Screw, shoulder (for cover) |

DCH-BLSN-33L / DCH-BLSN-33R

| | |
|---------------|------------------------------|
| *000-401-0048 | Cover Assembly, Slide, 11X25 |
| 3234282 | Hinge, Pan Cover, End, LH |
| 3234266 | Hinge, Pan Cover, End, RH |
| 9321041 | Nut, #10-24, Acorn, S/S |
| 9321374 | Pin, Hinge, Salad Pan |

DCH-SCS-33R / DCH-SCS-33L

| | |
|---------------|-------------------------------|
| *000-401-0047 | Cover Assembly, Slide, 6.5X25 |
| 3234282 | Hinge, Pan Cover, End, LH |
| 3234266 | Hinge, Pan Cover, End, RH |
| 9321041 | Nut, #10-24, Acorn, S/S |
| 9321374 | Pin, Hinge, Salad Pan |

* Part print on pages 11-12.

Condensing Unit Assembly

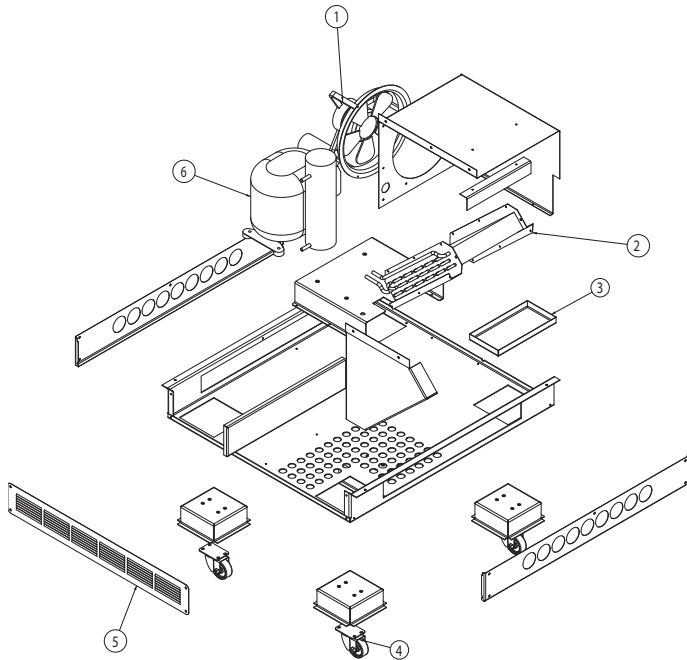

| Key | Part Number | Description |
|-----|---------------------|--|
| - | 000-BDJ-0032 | Condensing Unit Assembly |
| 1 | 2194013 | Fan assy, condenser, 8" blade |
| 2 | 3516297 | Coil, condenser |
| 3 | 223-099-0032 | Pan, evap, cond, 27" units |
| | 223-099-0030 | Pan, evap, cond, 32" units |
| 4 | 3234147 | Caster, 2", plate, swivel, hard rubber |
| 5 | 359-411-0037 | Panel, louvered, front, 27" units |
| | 359-411-0038 | Panel, louvered, front, 32" units |
| 6 | 3527000 | Compressor, 1/3HP, R404A, med |
| | 2194788 | Capacitor, start, 320MFD |
| | 3516438 | Relay, comp, OVLD, NF7CLX |
| | 3516443 | Cover, comp, small, Danfoss |
| - | 3516322 | Filter Drier |

Drawer Assembly Replacement Parts

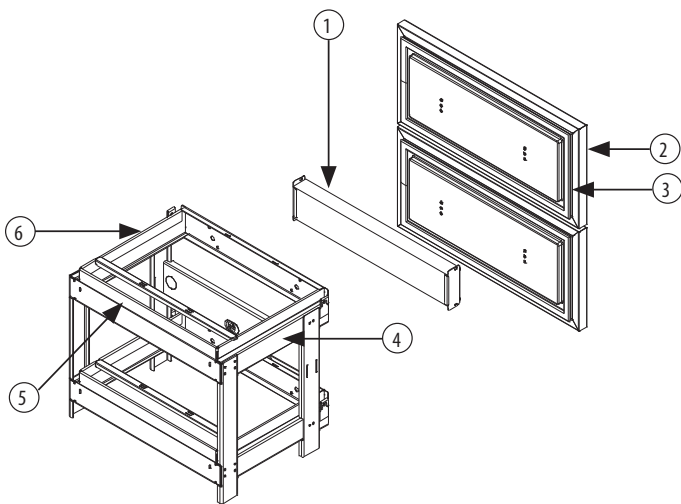

| Key | Part Number | Description |
|-----|---------------------|-----------------------------------|
| - | 000-AEW-007Z | Assembly, Drw Sys, 27 2-Hi |
| 1 | 000-315-0036 | Mullion Assembly |
| 2 | 000-327-0037 | Assy, 27 Drawer Frt 2-Hi |
| 3 | 1701192 | Gasket, Drw, 27, 2-high |
| 4 | 3234935 | Track, Drwr, Mid, Shallow, Lt |
| 5 | 000-333-004B | Assy, Drw Box, SHLW DP, 27 |
| 6 | 3234936 | Track, Drwr, Mid, Shallow, Rt |

Replacement Parts

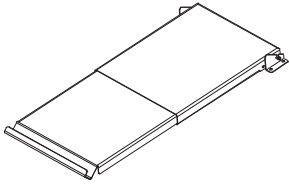

000-401-0046 - Cover Assembly, Slide, 10X25
000-401-0047 - Cover Assembly, Slide, 6.5X25
000-401-0048 - Cover Assembly, Slide, 11X25

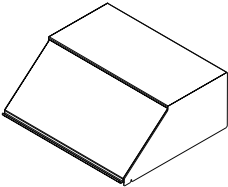

000-B2G-0035 - Cover, 27" double
000-B2G-0036 - Cover, 32" double

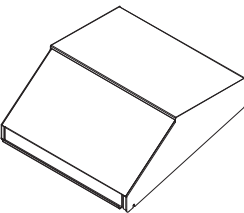

000-B2G-004B - Cover, 33" double, tall
000-B2G-004C - Cover, 32" double, tall
000-B2G-004D - Cover, 27" double, tall

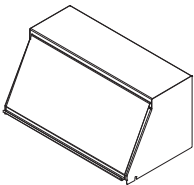

000-B2G-004A - Cover, 27" single, tall

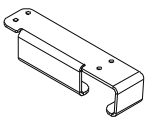

263-110-0035 - Bracket, cutting board, left

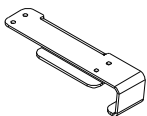

263-110-0037 - Bracket, cutting board, right

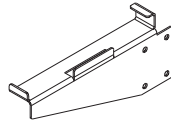

263-110-003C - Bracket, cutting board, 8", right

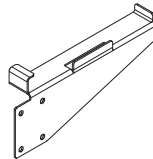

263-110-003D - Bracket, cutting board, 8", left

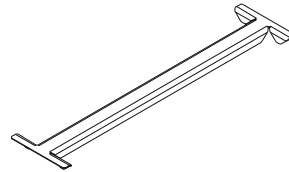

270-BEU-0036 - Divider, I-Bar Adapter, 2.93

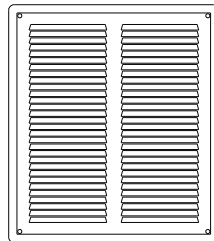

359-411-0039 - Louver, Left

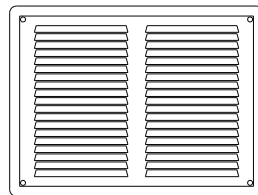

359-411-003A - Louver, Right

Standard Labor Guidelines To Repair Or Replace Parts On Delfield Equipment

Advice and recommendations given by Delfield Service Technicians do not constitute or guarantee any special coverage.

- A maximum of 1-hour is allowed to **diagnose a defective component**.
- A maximum of 1-hour is allowed for **retrieval of parts** not in stock.
- A maximum **travel distance** of 100 miles round trip and 2-hours will be reimbursed.
- Overtime, installation/start-up, normal control adjustments, general maintenance, glass breakage, freight damage, and/or correcting and end-user installation error will not be reimbursed under warranty unless pre-approved with a **Service Work Authorization** from Delfield. You must submit the number with the service claim.

LABOR OF 1-HOUR IS ALLOWED TO REPLACE:

- Thermostat
- Solenoid Coil
- Compressor Start Components and Overload Protector
- Condensate Element
- Evaporator/Condenser Fan Motor and Blade
- Hi-limit/Thermal Protector Switch
- Door Hinges, Locks, and Gaskets
- Thermometer

LABOR OF 2 HOURS TO REPLACE:

- Solenoid Valve
- Locate/Repair Leak

LABOR OF 3 HOURS TO REPLACE:

- Condenser or Evaporator Coil
- Expansion Valve

LABOR OF 4 HOURS TO REPLACE

- Compressor

This includes recovery of refrigerant and leak check.

\$55.00 maximum reimbursement for refrigerant recovery (includes recovery machine, pump, torch, oil, flux, minor fittings, solder, brazing rod, nitrogen, or similar fees.)

REFRIGERANTS

- R404A A maximum of \$15.00/lb.



Standard One Year Warranty (One year parts, 90 days labor)

The Delfield Company ("Delfield") warrants to the Original Purchaser of the Delfield product (herein called the "Unit") that such Unit, and all parts thereof, will be free from defects in material and workmanship under normal use and service for a period of one (1) year from the date of shipment of the Unit to the Original Purchaser or, if the Original Purchaser returns the warranty card completely filled out including the date of installation within thirty (30) days of receipt of the Unit, one (1) year from the date of installation. During this one year warranty period, Delfield will repair or replace any defective part or portion thereof returned to Delfield by the Original Purchaser which Delfield determines was defective due to faulty material or workmanship. The Original purchaser will pay all labor, crating, freight and related costs incurred in the removal of the Unit of defective component and shipment to Delfield, except that during a period of either ninety (90) days from the date of shipment of the Unit to the Original Purchaser or, if the Original Purchaser returns the warranty card completely filled out including the date of installation within thirty (30) days of receipt of the Unit, ninety (90) days from the date of installation Delfield will pay all related labor costs. Delfield will pay the return costs if the Unit or part thereof was defective.

The term "Original Purchaser" as used herein means that person, firm, association, or corporation for whom the Unit was originally installed.

This warranty does not apply to any Unit or part thereof that has been subjected to misuse, neglect, alteration, or accident, such as accidental damage to the exterior finish, operated contrary to the recommendations specified by Delfield; or repaired or altered by anyone other than Delfield in any way so as to, in Delfield's sole judgement, affect its quality or efficiency. This warranty does not apply to any Unit that has been moved from the location where it was originally installed. This warranty also does not cover the refrigerator drier or the light bulbs used in the Unit. The warranty is subject to the user's normal maintenance and care responsibility as set forth in the Service and Installation Manual, such as cleaning the condenser coil, and is in lieu of all other obligations of Delfield. Delfield neither assumes, nor authorizes any other person to assume for Delfield, any other liability in connection with Delfield's products.

Removal or defacement of the original Serial Number or Model Number from any Unit shall be deemed to release Delfield from all obligations hereunder or any other obligations, express or implied.

Parts furnished by suppliers to Delfield are guaranteed by Delfield only to the extent of the original manufacturer's express warranty to Delfield. Failure of the Original Purchaser to receive such manufacturer's express warranty to Delfield. Failure of the Original Purchaser to receive such manufacturer's warranty shall in no way create any warranty, expressed or implied, or any other obligation or liability on Delfield's part in respect thereof.

If shipment of a replacement part is requested prior to the arrival in the Delfield factory of the part claimed to be defective, the Original Purchaser must accept delivery of the replacement part of a C.O.D. basis, with credit being issued after the part has been received and inspected at Delfield's plant and determined by Delfield to be within this warranty.

Under no condition does this warranty give the Original Purchaser the right to replace the defective Unit with a complete Unit of the same manufacturer or of another make. Unless authorized by Delfield in writing, this warranty does not permit the replacement of any part, including the motor-compressor, to be made with the part of another make or manufacturer.

No claims can be made under this warranty for spoilage of any products for any reason, including system failure.

The installation contractor shall be responsible for building access, entrance and field conditions to insure sufficient clearance to allow any hood(s), vent(s), or Unit(s) if necessary, to be brought into the building. Delfield will not be responsible for structural changes or damages incurred during installation of the Unit or any exhaust system.

Delfield shall not be liable in any manner for any default or delay in performance hereunder caused by or resulting from any contingency beyond Delfield's control, including, but not limited to, war, governmental restrictions or restraints, strike, lockouts, injunctions, fire, flood, acts of nature, short or reduced supply of raw materials, or discontinuance of the parts by the original part manufacturer.

Except as provided in any Additional Four Year Protection Plan, if applicable, and the Service Labor Contract, if applicable, the foregoing is exclusive and in lieu of all other warranties, whether written or oral, express or implied. This warranty supersedes and excludes any prior oral or written representations or warranties. Delfield expressly disclaims any implied warranties of merchantability, fitness for a particular purpose of compliance with any law, treaty, rule or regulation relating to the discharge of substances into the environment. The sole and exclusive remedies of any person relating to the Unit, and the full liability of Delfield for any breach of this warranty, will be as provided in this warranty.

Other than this Delfield Standard One Year Limited Warranty, any applicable Delfield Additional Four Year Protection Plan or applicable Delfield Service Labor Contract, the Original Purchaser agrees and acknowledges that no other warranties are offered or provided in connection with or for the unit or any other part thereof.

In no event will Delfield be liable for special, incidental or consequential damages, or for damages in the nature of penalties.

Additional Four Year Protection Plan (For Motor-Compressor only)

| Delfield Model# | Serial # | Installation Date |
|----------------------|----------------------|----------------------|
| <input type="text"/> | <input type="text"/> | <input type="text"/> |

In addition to the Standard One Year Warranty on the Motor-Compressor contained in the above listed Delfield product (the "Unit"), The Delfield Company ("Delfield") also agrees to repair, or exchange with similar or interchangeable parts in design and capacity at Delfield's option, the defective Motor-Compressor contained in the Unit (the "Motor-Compressor), or any part thereof, for the Original Purchaser only, at any time during the four (4) years following the initial one (1) year period commencing on the date of installation for the Original Purchaser. Failure of the Original Purchaser to register the registration card containing the Original Purchaser's name, address, date of installation, model number and serial number of the Unit containing the Motor-Compressor within 30 days from the date of installation shall void this warranty. This additional warranty is only available if the Motor-Compressor is inoperative due to defects in material or factory workmanship, as determined by Delfield in its sole judgement and discretion. The Original Purchaser shall be responsible for returning the defective Motor-Compressor to Delfield prepaid, F.O.B. at the address shown on the back cover of this manual.

The term "Original Purchaser" as used herein means that person, firm, association, or corporation for whom the Unit was originally installed.

The term "Motor-Compressor" as used herein does not include unit base, air or water cooled condenser, receiver, electrical accessories such as relay, capacitors, refrigerant controls, or condenser fan/motor assembly. This warranty does not cover labor charges incidental to the replacement of parts. This warranty further does not include any equipment to which said condensing unit is connected, such as cooling coils, temperature controls or refrigerant metering devices. This warranty shall be void if the Motor-Compressor, in Delfield's sole judgement, has been subjected to misuse, neglect, alteration or accident, operated contrary to the recommendations specified by the Unit manufacturer, repaired or altered by anyone other than Delfield in any way so as, in Delfield's sole judgment, to affect its quality or efficiency or if the serial number has been altered, defaced or removed. This Warranty does not apply to a Motor-Compressor in any Unit that has been moved from the location where it was originally installed. The addition of methyl chloride to the condensing unit or refrigeration system shall void this warranty.

General Conditions

Delfield shall not be liable in any manner for any default or delay in performance hereunder caused by or resulting from any contingency beyond Delfield's control, including, but not limited to, war, governmental restrictions or restraints, strike, lockouts, injunctions, fire, flood, acts of nature, short or reduced supply of raw materials, or discontinuance of any part or the Motor-Compressor by the unit manufacturer.

Replacement of a defective Motor-Compressor is limited to one (1) Motor-Compressor by us during the four (4) year period. Delfield shall replace the Motor-Compressor at no charge.

This warranty does not give the Original Purchaser of the Motor-Compressor the right to purchase a complete replacement Motor-Compressor of the same make or of another make. It further does not permit the replacement to be made with a Motor-Compressor of another kind unless authorized by Delfield. In the event Delfield authorizes the Original Purchaser to purchase a replacement Motor-Compressor locally, only the wholesale cost of the Motor-Compressor is refundable.

Expressly excluded from this warranty are damages resulting from spoilage of goods.

Except as provided in any applicable Standard One Year Limited Warranty or applicable Service Labor Contract, the foregoing is exclusive and in lieu of all other warranties, whether written or oral, express or implied. This Warranty supersedes and excludes any prior oral or written representations or warranties. Delfield expressly disclaims any implied warranties of merchantability, fitness for a particular purpose or compliance with any law, treaty, rule or regulation relating to the Motor-Compressor, and the full liability of Delfield for any breach of this warranty, will be as provided in this warranty.

Other than any applicable Delfield Standard One year Limited Warranty, this Delfield Additional Four Year Protection Plan and any applicable Delfield Service Labor Contract, the Original Purchaser agrees and acknowledges that no other warranties are offered or provided in connection with or for the Motor-Compressor or any part thereof.

In no event will Delfield be liable for special, incidental or consequential damages, or for damages in the nature of penalties.





Mt. Pleasant, MI



Covington, TN

Thank you for choosing Delfield!

Help is a phone call away. Help our team of professional, courteous customer service reps by having your model number and serial number available at the time of your call (800) 733-8829.

Model: _____ S/N: _____

Installation Date: _____



For a list of Delfield's authorized parts depots, visit our website at www.delfield.com.

