

Specification Line®

Installation, Use and Care Manual

Please read this manual completely before attempting to install or operate this equipment! Notify carrier of damage! Inspect all components immediately.



**Important Information
Read Before Use
Please Save These Instructions!**



March 2013

Important Warning And Safety Information



WARNING

Read This Manual Thoroughly Before Operating, Installing, Or Performing Maintenance On The Equipment.



WARNING

Failure To Follow Instructions In This Manual Can Cause Property Damage, Injury Or Death.



WARNING

Do Not Store Or Use Gasoline Or Other Flammable Vapors Or Liquids In The Vicinity Of This Or Any Other Appliance.



WARNING

Unless All Cover And Access Panels Are In Place And Properly Secured, Do Not Operate This Equipment.



WARNING

This Appliance Is Not Intended For Use By Persons Who Lack Experience Or Knowledge, Unless They Have Been Given Supervision Or Instruction Concerning Use Of The Appliance By A Person Responsible For Their Safety.



WARNING

This Appliance Is Not To Be Played With.



WARNING

Do Not Clean With Water Jet.



WARNING

Do Not Use Electrical Appliances Inside The Food Storage Compartment Of This Appliance.



CAUTION

Observe the following:

- Minimum clearances must be maintained from all walls and combustible materials.
- Keep the equipment area free and clear of combustible material.
- Allow adequate clearance for air openings.
- Operate equipment only on the type of electricity indicated on the specification plate.
- Unplug the unit before making any repairs.
- Retain this manual for future reference.

Contents

Receiving And Inspecting The Equipment	3
Serial Number	4
Warranty Information.....	4
Model Numbers	5
Introduction	6
Specifications.....	7-12
Installation	13-14
Heated Cabinet Operation	15
Electronic Temperature Control Operation	16-17
Door Reversal Procedures	18
Maintenance.....	19-20
Wiring Diagrams.....	21-28
Compressor Diagrams.....	29
Replacement Parts.....	30-32
Standard Labor Guidelines.....	33
Notes	34-35

Receiving And Inspecting The Equipment

Even though most equipment is shipped crated, care should be taken during unloading so the equipment is not damaged while being moved into the building.

1. Visually inspect the exterior of the package on skid or container. Any damage should be noted and reported to the delivering carrier immediately.
2. If damaged, open and inspect the contents with the carrier.
3. In the event that the exterior is not damaged, yet upon opening, there is concealed damage to the equipment notify the carrier. Notification should be made verbally as well as in written form.
4. Request an inspection of the concealed equipment. This should be done within 10 days from receipt of the equipment.
5. Check the lower portion of the unit to be sure legs or casters are not bent.
6. Also open the compressor compartment housing and visually inspect the refrigeration package. Be sure lines are secure and base is still intact.
7. Freight carriers can supply the necessary forms upon request.
8. Retain all crating material until an inspection has been made or waived.

Uncrating the Equipment

First cut and remove the banding from around the crate. Remove the front of the crate material, use of some tools will be required. If the unit is on legs remove the top of the crate as well and lift the unit off the skid. If the unit is on casters it can be "rolled" off the skid.

Serial Number Location

The serial number is on the identification plate that also includes the model number. On refrigeration and freezer units the identification plate is located inside the left most door near the top front corner of the left interior wall. On heated units, the identification plate is located in the shroud area on the right side panel.

Always have the serial number of your unit available when calling for parts or service. A complete list of authorized Delfield parts depots can be found at www.delfield.com.

©2013 The Delfield Company. All rights reserved. Reproduction without written permission is prohibited. "Delfield" is a registered trademark of The Delfield Company.

Warranty Information

Visit http://www.delfield.com/minisite/service/warranty_info to:

- Register your product for warranty.
- Verify warranty information.
- View and download a copy of your warranty.

Model Numbers

Series	Finish	Temp	Configuration	Section	Size	System	Doors
S=Specification Line	S=Stainless interior & exterior A=Stainless exterior, aluminum interior M=Stainless front, aluminum sides and interior	R=Refrigerator F=Freezer H=Heated D=Dual Temp	None=Reach-in PT=Pass Thru RI=Roll-in RT=Roll Thru FF=Fish Drawers RL=Refrigerator Left FL=Freezer Left TR=Top Refrigerator BR=Bottom Refrigerator TP=Top Refrigerator Pass Thru BP=Bottom Refrigerator Pass Thru RP=Refrigerator Left Pass Thru FP=Freezer Left Pass Thru	1=1 Section 2=2 Section 3=3 Section	None=Standard N=Narrow S=Shallow	None=Standard E=Export Voltage R=Remote	S=Solid Full SH=Solid Half G=Hinged Glass Full GH=Hinged Glass Half SL=Sliding Glass Full SLH=Sliding Glass Half SLS=Sliding Solid Full SLSH=Sliding Solid Half D=Drawers

Introduction

Model numbers starting with the letters “SS” have a stainless steel exterior and interior. Model numbers starting with the letters “SA” have an aluminum interior and a stainless steel exterior. Model numbers starting with the letters “SM” have an aluminum interior and exterior with a stainless steel front and shroud. Door gaskets are magnetic and mount to the door, snapping in place and are removable without tools. Keyed door lock is mounted in the door next to the handle.

Doors can be removed from the cabinet without the use of tools. Each door has two edge mount, self-closing, cam lift style hinges.

Refrigeration System

All components are mounted to the exterior cabinet ceiling, outside the food zone and are assembled as one-piece and can be removed as one-piece. Environmentally friendly R404A refrigerant is used. The system has the capability of maintaining between 33°F and 40°F (1°C and 4°C) in heavy use food service operations. Refrigerant is metered using a highly responsive thermostatic expansion valve. Systems are controlled using Delfield's ACT Electronic Temperature Control. It provides improved pull down times, reducing compressor cycling and longer compressor life with lower energy consumption. Control system uses adaptive defrost to assure evaporator coil is free of ice and operating at optimum efficiency. Evaporator condensate is eliminated using an energy efficient hot gas system.

Freezer Refrigeration System

All components are mounted to the exterior cabinet ceiling, outside the food zone and are assembled as one-piece and can be removed as one-piece. Environmentally friendly R404A refrigerant is used. The system has the capability of maintaining between -5°F and 0°F (-21°C and -18°C) in heavy use food service operations. Refrigerant is metered using a highly responsive thermostatic expansion valve. System is controlled using Delfield's ACT Electronic Temperature Control, which provides improved pull down times, reducing compressor cycling and longer compressor life with lower energy consumption. Control system uses adaptive defrost to assure evaporator coil is free of ice and operating at optimum efficiency. Evaporator condensate is eliminated using an energy efficient hot gas system.

Heating System

Heating system cabinets are designed to maintain temperatures between 120°F and 200°F (49°C and 93°C). Heating elements are helical shaped, with tubular fins. A circulating fan provides uniform airflow in the cabinet. The entire heating system is mounted to the exterior of the cabinet ceiling, outside the food zone. It is assembled as one piece and can be removed as one piece. An adjustable electronic thermostat controls temperature. The system ON/OFF switch is located on the front exterior of the cabinet.

Service Alert

During normal operation the evaporator fan may cycle and/or pulse independently of the compressor. Consult the service manual or contact Technical Support at 1-800-733-8829 if you are unsure of the proper function.

Dual Temperature Refrigeration/Freezer

Each compartment has its own separate refrigeration system. Condensing units are located on top of the cabinet, outside the food zone, behind the upper shroud. Evaporator coils are located inside the cabinet mounted to the interior ceiling of each compartment. Defrost is automatic. Condensate travels down a tube in the cabinet sidewall to a receptacle mounted to the exterior bottom of the cabinet where it evaporates with the aid of an electric heater. Each compartment's temperature is individually monitored and controlled with Delfield's ACT Electronic Temperature Control. Two exterior digital thermometers monitor temperature. Refrigerator compartment maintains temperature between 33°F and 41°F (1°C and 5°C). Freezer compartment maintains temperature between -5°F and +5°F (-21°C and -15°C). Refrigerant is metered using a highly responsive thermostatic expansion valve.

Power Switch

Select units are equipped with a power disconnect switch located next to the energy saver switch and thermostat control knob. Switch must be in the “on” position for the unit to operate. On freezers, if the switch is turned off, then returned to the on position, the unit will enter a defrost cycle and the display will read “Def.”

Specifications

Reach-In Refrigerators - Hinged Doors - Standard Width & Depth

Model	Voltage	Amps	Volume Ft ³	Shelf Capacity Ft ²	No. Of Shelves	H.P.	BTU/HR	R-404A Charge Oz.	Shipping Weight	NEMA Plug
SSR1-S,SH,G,GH SAR1-S,SH,G,GH SMR1-S,SH,G,GH	115	6.0	24.96	12.81	3	1/4	2092	12.5	418lbs/190kg	5-15P
SSR2-S,SH,G,GH SAR2-S,SH,G,GH SMR2-S,SH,G,GH	115	9.5	51.92	27.54	6	1/3	3226	19	650lbs/295kg	5-15P
SSR3-S,SH,G,GH SAR3-S,SH,G,GH SMR3-S,SH,G,GH	115	14.5	78.89	42.47	9	1/2	5465	24	830lbs/376kg	5-20p

Reach-In Refrigerators - Hinged Doors - Narrow Width

Model	Voltage	Amps	Volume Ft ³	Shelf Capacity Ft ²	No. Of Shelves	H.P.	BTU/HR	R-404A Charge Oz.	Shipping Weight	NEMA Plug
SSR1N-S,SH,G,GH SAR1N-S,SH,G,GH SMR1N-S,SH,G,GH	115	6.0	20.97	10.59	3	1/4	2092	12.5	398lbs/181kg	5-15P
SSR2N-S,SH,G,GH SAR2N-S,SH,G,GH SMR2N-S,SH,G,GH	115	9.5	43.94	23.10	6	1/3	3226	19	588lbs/267kg	5-15P

Reach-In Refrigerators - Hinged Doors - Shallow Depth

Model	Voltage	Amps	Volume Ft ³	Shelf Capacity Ft ²	No. Of Shelves	H.P.	BTU/HR	R-404A Charge Oz.	Shipping Weight	NEMA Plug
SSR1S-S,SH,G,GH SAR1S-S,SH,G,GH SMR1S-S,SH,G,GH	115	6.0	18.25	12.81	3	1/4	2092	12.5	396lbs/180kg	5-15P
SSR2S-S,SH,G,GH SAR2S-S,SH,G,GH SMR2S-S,SH,G,GH	115	7.0	37.96	27.54	6	1/3	2488	12.5	586lbs/266kg	5-15P

Reach-In Refrigerators - Sliding Doors

Model	Voltage	Amps	Volume Ft ³	Shelf Capacity Ft ²	No. Of Shelves	H.P.	BTU/HR	R-404A Charge Oz.	Shipping Weight	NEMA Plug
SSR2-SLS,SLSH, SLG,SLGH SAR2-SLS,SLSH, SLG,SLGH SMR2-SLS,SLSH, SLG,SLGH	115	9.5	51.92	27.54	6	1/3	3226	19	670lbs/304kg	5-15P
SSR2S-SLS,SLSH, SLG,SLGH SAR2S-SLS,SLSH, SLG,SLGH SMR2S-SLS,SLSH, SLG,SLGH	115	7.0	37.96	27.54	6	1/3	2488	12.5	670lbs/304kg	5-15P

Specifications, continued

Reach-In Refrigerator/Freezer Combinations - Dual Temps - Hinged Doors - Standard Width & Depth

Model	Section	V	Amps	Volume Ft ³	Shelf Capacity Ft ²	No. Of Shelves	H.P.	BTU/HR	R-404A Charge Oz.	Shipping Weight	NEMA Plug
SSDTR1-SH, GH, SSDBR1-SH, GH, SADTR1-SH, GH, SADBR1-SH, GH, SMDTR1-SH, GH, SMDBR1-SH, GH	Refrigerator	115	12.0	10.81	4.23	2	1/5	1543	11	525lbs/238kg	5-20P
	Freezer			10.81	4.23	2	1/4	1260	12		
SSDRL2-S,SH, SSDFL2-S,SH, SADRL2-S,SH, SADFL2-S,SH, SMDRL2-S,SH, SMDFL2-S,SH	Refrigerator	115	15.0	24.96	12.81	3	1/4	2092	12.5	730lbs/331kg	5-20P
	Freezer			24.96	12.81	3	1/2	1516	12.5		
SSDRL2-G,GH SSDFL2-G,GH SADRL2-G,GH SADFL2-G,GH SMDRL2-G,GH SMDFL2-G,GH	Refrigerator	115/ 208- 230	8.0	24.96	12.81	3	1/4	2092	12.5	730lbs/331kg	14-20P
	Freezer			24.96	12.81	3	1/2	1923	12.5		

Pass-Thru Refrigerator/Freezer Combinations - Dual Temps - Hinged Doors - Standard Width & Depth

Model	Section	V	Amps	Volume Ft ³	Shelf Capacity Ft ²	No. Of Shelves	H.P.	BTU/HR	R-404A Charge Oz.	Shipping Weight	NEMA Plug
SSDRP2-S,SH, SSDFP2-S,SH SADRP2-S,SH, SADFP2-S,SH SMDRP2-S,SH, SMDFP2-S,SH	Refrigerator	115/ 208- 230	8.0	24.96	12.81	3	1/4	2092	12.5	730lbs/331kg	14-20P
	Freezer			24.96	12.81	3	3/4	1923	12.5		

Reach-In Hot Food Cabinets - Hinged Doors - Standard Width & Depth

Model	Voltage	Amps	Volume Ft ³	Shelf Capacity Ft ²	No. Of Shelves	Shipping Weight	NEMA Plug
SSH1-S,SH,G,GH SAH1-S,SH,G,GH SMH1-S,SH,G,GH	120/208-240	9.0	24.96	12.81	3	418lbs/190kg	N/A
SSH2-S,SH,G,GH SAH2-S,SH,G,GH SMH2-S,SH,G,GH	120/208-240	16.0	51.92	27.54	6	650lbs/295kg	N/A
SSH3-S,SH,G,GH SAH3-S,SH,G,GH SMH3-S,SH,G,GH	120/208-240	17.8	78.89	42.47	9	830lbs/376kg	N/A

Reach-In Hot Food Cabinets - Hinged Doors - Narrow Width

Model	Voltage	Amps	Volume Ft ³	Shelf Capacity Ft ²	No. Of Shelves	Shipping Weight	NEMA Plug
SSH2N-S,SH SAH2N-S,SH SMH2N-S,SH	120/208-240	16.0	43.94	27.54	6	588lbs/267kg	N/A

Specifications, continued

Pass-Thru Hot Food Cabinets - Hinged Doors - Standard Width & Depth

Model	Voltage	Amps	Volume Ft ³	Shelf Capacity Ft ²	No. Of Shelves	Shipping Weight	NEMA Plug
SSHPT1-S,SH SAHPT1-S,SH SMHPT1-S,SH	120/208-240	9.0	26.96	12.81	3	398lbs/181kg	N/A
SSHPT2-S,SH SAHPT2-S,SH SMHPT2-S,SH	120/208-240	16.0	51.92	27.54	6	650lbs/295kg	N/A

Reach-In Freezers - Hinged Doors - Standard Width & Depth

Model	Voltage	Amps	Volume Ft ³	Shelf Capacity Ft ²	No. Of Shelves	H.P.	BTU/HR	R-404A Charge Oz.	Shipping Weight	NEMA Plug
SSF1-S,SH SAF1-S,SH SMF1-S,SH	115	9.0	24.96	12.81	3	1/2	1516	12.5	440lbs/200kg	5-15p
SSF1-G,GH SAF1-G,GH SMF1-G,GH	115	11.0	24.96	12.81	3	3/4	1923	12.5	440lbs/200kg	5-15p
SSF2-S,SH SAF2-S,SH SMF2-S,SH	115	14.3	51.92	27.54	6	3/4	2648	17	710lbs/322kg	5-20P
SSF2-G,GH SAF2-G,GH SMF2-G,GH	115/ 208-230	12.6	51.92	27.54	6	1	4793	30	710lbs/322kg	N/A
SSF3-S,SH SAF3-S,SH SMF3-S,SH	115/ 208-230	12.6	78.89	42.47	9	1	4793	30	960lbs/435kg	N/A

Reach-In Freezers - Hinged Doors - Narrow Width

Model	Voltage	Amps	Volume Ft ³	Shelf Capacity Ft ²	No. Of Shelves	H.P.	BTU/HR	R-404A Charge Oz.	Shipping Weight	NEMA Plug
SSF1N-S,SH SAF1N-S,SH SMF1N-S,SH	115	9.0	20.97	10.59	3	1/2	1516	12.5	408lbs/185kg	5-15p
SSF2N-S,SH SAF2N-S,SH SMF2N-S,SH	115	14.3	43.94	23.10	6	3/4	2648	17	680lbs/308kg	5-20P

Reach-In Freezers - Hinged Doors - Shallow Depth

Model	Voltage	Amps	Volume Ft ³	Shelf Capacity Ft ²	No. Of Shelves	H.P.	BTU/HR	R-404A Charge Oz.	Shipping Weight	NEMA Plug
SSF1S-S,SH SAF1S-S,SH SMF1S-S,SH	115	9.0	18.25	8.98	3	1/2	1516	12.5	406lbs/184kg	5-15p
SSF2S-S,SH SAF2S-S,SH SMF2S-S,SH	115	11.0	37.96	19.04	6	3/4	1923	12.5	676lbs/307kg	5-15P

Specifications, continued

Pass-Thru Refrigerators - Hinged Doors - Standard Width

Model	Voltage	Amps	Volume Ft ³	Shelf Capacity Ft ²	No. Of Shelves	H.P.	BTU/HR	R-404A Charge Oz.	Shipping Weight	NEMA Plug
SSRPT1-S,SH SARPT1-S,SH SMRPT1-S,SH	115	6.0	26.64	12.81	3	1/4	2092	12.5	455lbs/206kg	5-15P
SSRPT1-G,GH SARPT1-G,GH SMRPT1-G,GH	115	7.0	26.64	12.81	3	1/3	2488	12.5	455lbs/206kg	5-15P
SSRPT2-S,SH SARPT2-S,SH SMRPT2-S,SH	115	14.5	55.42	27.54	6	1/2	5465	24	700lbs/318kg	5-20P
SSRPT2-G,GH SARPT2-G,GH SMRPT2-G,GH	115	14.5	55.42	27.54	6	1/2	5465	24	700lbs/318kg	5-20P

Pass-Thru Refrigerators - Hinged Doors - Shallow Depth

Model	Voltage	Amps	Volume Ft ³	Shelf Capacity Ft ²	No. Of Shelves	H.P.	BTU/HR	R-404A Charge Oz.	Shipping Weight	NEMA Plug
SSRPT1S-S,SH SARPT1S-S,SH SMRPT1S-S,SH	115	6.0	18.25	8.98	3	1/3	2092	12.5	455lbs/206kg	5-15P
SSRPT2S-S,SH SARPT2S-S,SH SMRPT2S-S,SH	115	7.0	37.96	19.04	6	1/3	2488	12.5	700lbs/318kg	5-15P

Pass-Thru Freezers - Hinged Doors - Standard Width

Model	Voltage	Amps	Volume Ft ³	Shelf Capacity Ft ²	No. Of Shelves	H.P.	BTU/HR	R-404A Charge Oz.	Shipping Weight	NEMA Plug
SSFPT1-S,SH SAFPT1-S,SH SMFPT1-S,SH	115	11.0	26.64	12.81	3	3/4	1923	12.5	672lbs/305kg	5-15p

Fish Drawer Reach-In - Four Fish Drawers Per Section

Model	Voltage	Amps	Volume Ft ³	Shelf Capacity Ft ²	No. Of Shelves	H.P.	BTU/HR	R-404A Charge Oz.	Shipping Weight	NEMA Plug
SSRFF1	115	6.0	24.96	N/A	N/A	1/4	2092	12.5	418lbs/190kg	5-15P
SSRFF2	115	9.5	51.92	N/A	N/A	1/3	3226	19	650lbs/295kg	5-15P

Specifications, continued

Roll-In Refrigerators

Model	Voltage	Amps	Volume Ft ³	Shelf Capacity Ft ²	No. Of Shelves	H.P.	BTU/HR	R-404A Charge Oz.	Shipping Weight	NEMA Plug
SSRRI1-S SARRI1-S SMRRI1-S	115	6.0	36.15	N/A	N/A	1/4	2092	12.5	476lbs/216kg	5-15P
SSRRI1-G SARRI1-G SMRRI1-G	115	7.0	36.15	N/A	N/A	1/3	2488	12.5	476lbs/216kg	5-15P
SSRRI2-S SARRI2-S SMRRI2-S	115	9.5	76.34	N/A	N/A	1/3	3226	19	768lbs/348kg	5-15P
SSRRI2-G SARRI2-G SMRRI2-G	115	14.5	76.34	N/A	N/A	1/2	5465	24	768lbs/348kg	5-20P
SSRRI3-S SARRI3-S SMRRI3-S	115	14.5	113.28	N/A	N/A	1/2	5465	24	1044lbs/4774kg	5-20p

Roll-In Freezers

Model	Voltage	Amps	Volume Ft ³	Shelf Capacity Ft ²	No. Of Shelves	H.P.	BTU/HR	R-404A Charge Oz.	Shipping Weight	NEMA Plug
SSFRI1-S SAFRI1-S SMFRI1-S	115	11.0	36.15	N/A	N/A	3/4	1923	12.5	497lbs/225kg	5-15p
SSFRI2-S SAFRI2-S SMFRI2-S	115/ 208-230	12.6	76.34	N/A	N/A	1	4793	30	824lbs/374kg	N/A

Specifications, continued

Hot Food Roll-Ins

Model	Voltage	Amps	Volume Ft ³	Shelf Capacity Ft ²	No. Of Shelves	Shipping Weight	NEMA Plug
SSHRI1-S,G SAHRI1-S,G SMHRI1-S,G	120/208-240	9.0	36.15	N/A	N/A	459lbs/ 208kg	N/A
SSHRI2-S, G SAHRI2-S, G SMHRI2-S, G	120/208-240	16.0	76.34	N/A	N/A	704lbs/ 319kg	N/A
SSHRI3-S, G	120/208-240	17.8	113.28	N/A	N/A	1008lbs/457kg	N/A

Roll-Thru Refrigerators - Hinged Doors

Model	Voltage	Amps	Volume Ft ³	Shelf Capacity Ft ²	No. Of Shelves	H.P.	BTU/HR	R-404A Charge Oz.	Shipping Weight	NEMA Plug
SSRRT1-S SARRT1-S SMRRT1-S	115	7.0	38.58	N/A	N/A	1/3	2488	12.5	514lbs/233kg	5-15P
SSRRT2-S SARRT2-S SMRRT2-S	115	14.5	79.74	N/A	N/A	1/2	5465	24	776lbs/352kg	5-20P

Roll-Thru Hot Food Cabinets - Hinged Doors

Model	Voltage	Amps	Volume Ft ³	Shelf Capacity Ft ²	No. Of Shelves	Shipping Weight	NEMA Plug
SSHRT1-S SAHRT1-S SMHRT1-S	120/208-240	9.0	38.58	N/A	N/A	519lbs/ 235kg	N/A
SSHRT2-S SAHRT2-S SMHRT2-S	120/208-240	16.0	79.74	N/A	N/A	836lbs/ 379kg	N/A
SSHRT3-S SAHRT3-S	120/208-240	17.8	120.90	N/A	N/A	985lbs/ 447kg	N/A

Installation

Location

Cabinets represented in this manual are intended for indoor use only. Be sure the location chosen has a floor strong enough to support the total weight of the cabinet, 1000 pounds. per door section. Reinforce the floor if necessary to provide for maximum loading. For the most efficient operation, be sure to provide good air circulation inside and out. The location should be selected so that the power cord can be connected without any extensions.

Inside Unit

Take care not to block airflow to the fans or heating elements and allow space along the front, back and sides.

Outside Unit

Be sure that the unit has access to ample air; avoid hot corners and locations near stoves and ovens. Provide a minimum clearance of 12" (30.5 cm) above the unit that is open to the front.



NOTE

Due to the unique design of the One Door Dual Temp units (ie: SSDTR1-SH), a 6" clearance is required at the back of the unit to ensure proper operation.

Door Removal

The doors can be removed during installation if necessary. Remove the door by opening the door to 90°, lift it up and ease it out of the hinge brackets

Leg, Caster, Utility Base Installation



WARNING

Some cabinets may weigh over 1000 pounds (450 kg). Use a lifting device capable of supporting the unit when removing skid or installing legs, casters or utility base.

To install the legs, or casters refer to Figure 1. To install the utility base, refer to Figure 2. Proceed as follows:

1. Remove unit from skid.
2. Raise unit to access leg/caster mounting holes on bottom of unit.
3. Attach the legs, casters or utility base to bottom of cabinet using hex head bolts.

Leveling

After the cabinet has been placed in the desired location, cabinets with legs must be leveled. Level units from front to back and from side to side. Leveling will insure proper door operation and removal of condensate. Cabinets with casters must have the caster brake set so the cabinet cannot move.

Stabilizing

It is very important that all legs are properly adjusted to keep the cabinet level, evenly distribute the weight and to make sure the unit will not rock, lean or be unstable.

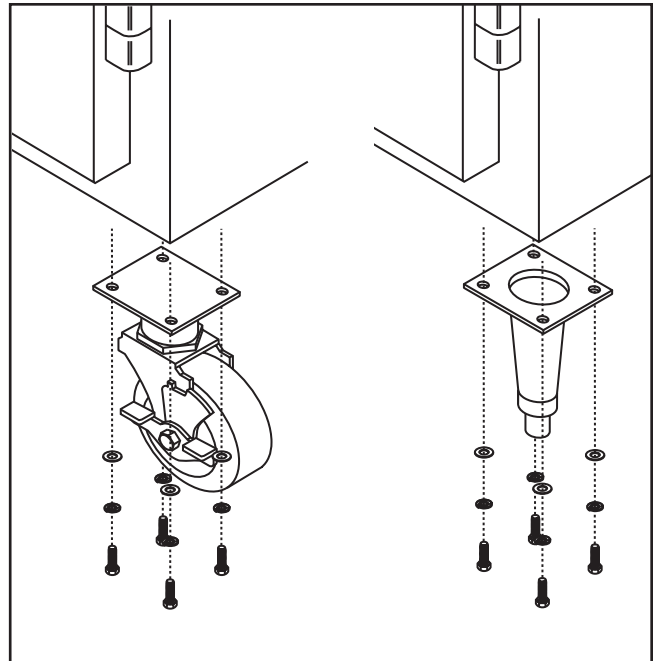

Figure 1. Leg or Caster Installation

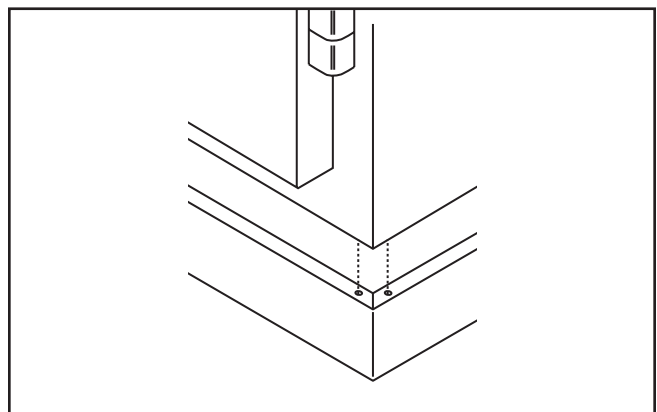

Figure 2. Utility Base Installation

Installation, continued

Electrical Connection



Refer to the amperage data list in the SPECIFICATIONS or the serial tag data and your local code or the National Electrical Code to be sure the unit is connected to the proper power source. A protected circuit of the correct voltage and amperage must be run for connection of the supply cord or permanent connection to the unit. The power must be turned off and disconnected whenever performing maintenance or repair functions.



Permanently connected units must be connected in accordance with NEC Article 422 Appliances, C-Disconnecting means. It is the responsibility of the end user to provide the disconnect means to satisfy the authority having jurisdiction.

The power cords supplied with this equipment are three-pronged plugs and must be connected to a three-pronged wall outlet for proper grounding. Do not use an adapter to connect to a two-pronged outlet. The three pronged-outlet provides a ground connection which must be used to prevent a shock hazard.



Have the wall outlet checked by a qualified electrician to be sure a proper ground is present and that the outlet provides the correct voltage and required amperage to match the rating plate.

Any power cord that is frayed or damaged should be replaced. When disconnecting the unit from the power source, do not pull on the wire. Firmly grip the plug and remove from outlet.

The plugs shown in Figure 3 are used on the various models.

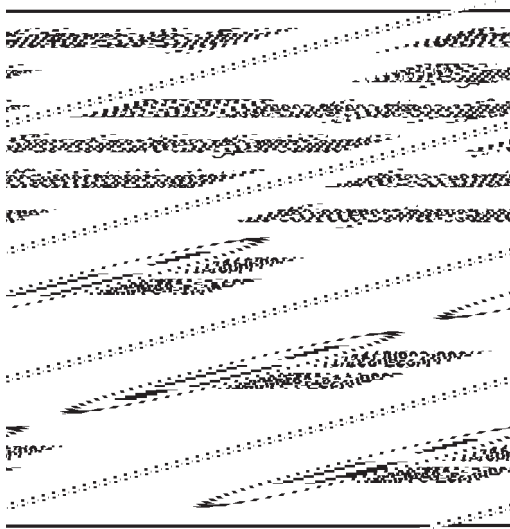

Figure 3. Plug Configurations

Power Switch

Select units are equipped with a power disconnect switch located next to the energy saver switch and thermostat control knob. Switch must be in the “on” position for the unit to operate. On freezers, if the switch is turned off, then returned to the on position, the unit will enter a defrost cycle and the display will read “Def.”

Heated Cabinet Operation

The Heated units have a POWER ON/OFF switch located behind the flip up shroud at the front top of the unit for controlling power to the unit and an electronic thermostat for setting the temperature. A circulating fan provides uniform airflow in the cabinet.

Power Up

1. Check that unit is properly connected to the power source.
2. Raise the shroud to access the controls.
3. Set the Main POWER ON/OFF switch, to the ON position.
4. Set the NIGHT switch to the ON position.
5. Adjust the electronic thermostat to the desired temperature.
6. Allow unit to warm-up before use.



The unit surface is very hot! Avoid direct contact with skin; use appropriate protective apparel, such as gloves.

Power Down

1. Turn the unit off daily by setting the NIGHT switch to the OFF position
2. After use, allow unit to cool down.
3. If desired, set the Main POWER ON/OFF switch to the OFF position.
4. Clean equipment as discussed in the MAINTENANCE section of this manual.

Electronic Temperature Control Operation

These instructions are applicable to most models,

The electronic temperature control constantly monitors box temperature as well as evaporator coil temperature to maintain consistent product temperatures. The control also sends temperature readings to the digital temperature display. The control circuits continually self-check and if an error occurs, the digital display will switch from temperature read-out to error read-out, i.e. E1. Even when an error is displayed, the refrigeration and controls system should continue to function, however not at optimal performance. Whenever the display has an error read-out, Delfield Service should be contacted.

At initial start-up or anytime power is disconnected, then reconnected to the unit, the control will delay all operations for a short time (up to 10 minutes.) While in this delay period, the control initializes the control parameters and confirms that the temperature sensors and circuits are operational. The digital temperature display will not display temperature OR errors until the self-check is complete and the control has switched on the evaporator fan motor, compressor and condenser fan motor.



Regarding Freezers: After initializing, the control will immediately enter a DEFROST mode and the display will read DEF. The compressor and condenser fan as well as the evaporator fan will remain off until initialization defrost is complete. This initial defrost cycle may take up to 15 minutes to complete, at which time the freezing cycle will begin. The display will continue to read DEF for an additional 30 minutes before displaying temperature.

The control is located in the control box in the top of the unit behind the hinged louvered front panel. Refrigerators are factory set at mid-range to maintain about 38°F (3°C) box temperature. Freezers are factory set at mid-range to maintain about 3°F (-18°C) box temperature. To adjust for colder temperatures, turn the knob clockwise. For warmer temperatures, turn the knob counter-clockwise. Turn the knob fully counter-clockwise to turn the refrigeration system off. Never turn the knob more than 1 dial number and always allow 8 hours for temperature stabilization before making any additional adjustments.

Temperature Alarm:

The alarm will flash "HI" or "LO" 90 minutes after the unit has reached its alarm temperature point or after any power interruption if the temperature is above or below the alarm set points. Refrigerators are factory set at mid-range to maintain about 38°F (3°C) box temperature. The high refrigerator temperature point is 50°F (10°C). The low refrigerator temperature point is 25°F (-4°C). Freezers are factory set at mid-range to maintain about 3°F (-18°C) box temperature. The high freezer temperature point is 20°F (-7°C). Freezers do not have a low temperature point.

Refrigerator:

Whenever the refrigerator is plugged in, and the control has completed initializing, the digital thermostat will display box temperature. The temperature control will cycle the compressor, evaporator fan motor and condenser fan motor to maintain box temperature at the control setting. See evaporator fan matrix for more information.

Refrigerator Defrost

The temperature control also monitors the evaporator temperature and will turn off the compressor and condenser fan motor when needed to allow accumulated frost on the evaporator to clear. During this defrost cycle, the digital temperature display will read dEF. After the defrost cycle is complete, the temperature control will return to a normal cooling cycle, but the display will continue to read dEF until the evaporator returns to normal cooling temperatures (up to 15 minutes).

Power Switch

Select units are equipped with a power disconnect switch located next to the energy saver switch and thermostat control knob. Switch must be in the "on" position for the unit to operate. On freezers, if the switch is turned off, then returned to the on position, the unit will enter a defrost cycle and the display will read "Def."

Energy Saver Switch

The energy saver switch is a rocker switch located next to the thermostat knob that controls the amount of heat applied to the door perimeter. The normal operating position for this switch is the

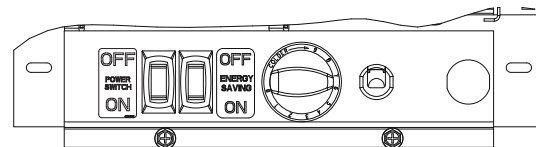

ON position, providing the least heat. If excessive condensation is observed on the door opening, press the energy saver switch to the OFF position, to increase the amount of heat (red portion of the rocker switch will be visible). Note: This feature is not present on Dual Temperature models.

Freezer:

Whenever the freezer is plugged in, and the control has completed initializing including the initial defrost cycle, the thermostat will display box temperature. The temperature control will cycle the compressor, evaporator fan motor and condenser fan motor to maintain box temperature at the control setting. See evaporator fan matrix for more information.

Electronic Temperature Control Operation, continued

Freezer Automatic Defrost

The control also monitors compressor total running time and will enter a defrost cycle after total compressor running time is greater than 4-hours since the last defrost cycle OR if evaporator coil temperature drops below -30°F (-34°C) (indicating excessive frost on the coil.)

Freezer Manual Defrost

If a manual defrost is desired, simply unplug the unit for several seconds, then plug unit back in. This will cause the control to re-initialize and then enter a defrost cycle.

When the control enters the defrost mode, it switches off the evaporator fan motor, compressor and condenser fan motor, and switches on the defrost heater to warm the evaporator coil. Thereby melting all frost accumulated during the previous refrigeration cycle. The digital temperature display will now read dEF. The control will continue the defrost cycle for a MINIMUM of 8 minutes and a MAXIMUM of 30 minutes depending on the amount of frost accumulated on the evaporator coil.

After the defrost cycle is complete, the control returns to a normal refrigeration cycle, however the evaporator fan motor will not switch on for 2 minutes AFTER the compressor and condenser fan motor have begun operating. The digital temperature display will continue to read dEF until the evaporator has returned to normal freezing temperatures (up to 30 minutes).

Dual Temperature Refrigerator/Freezer Cabinets

These units combine both a refrigerator compartment and a freezer compartment in the same cabinet. Each compartment has its own separate refrigeration unit and Electronic Temperature Control.



Regarding Single Section Dual Temperature Units: After initializing, the both controls will immediately enter a DEFROST mode and the displays will read DEF. The compressor and condenser fan as well as the evaporator fan will remain off until initialization defrost is complete. This initial defrost cycle may take up to 15 minutes to complete, at which time the freezing cycle will begin. The displays will continue to read DEF for an additional 30 minutes before displaying temperature.

Service Alert

During normal operation the evaporator fan may cycle and/or pulse independently of the compressor. Consult the service manual or contact Technical Support at 1-800-733-8829 if you are unsure of the proper function.

Evaporator Fan Operation

	Cooling Cycle				Defrost Cycle	
	Compressor On		Compressor Off		Compressor Off	
	Evap Fan On	Evap Fan Off	Evap Fan On	Evap Fan Off	Evap Fan On	Evap Fan Off
Refrigerator	X		Cycles On 3-Min, Off 3-Min		X	
Freezer	X			X		X
Dual Temp Refrigerator	X			X	X	
Freezer	X			X		X

Door Reversal Procedures

Only for Models Ordered With Re-Hinging Option.

The re-hinging option is only available on solid door models.

1. Lift front shroud if re-hinging the control side. If re-hinging the rear side, the shroud must be removed.
2. Open door 90° and lift door straight up and off hinges.
3. Remove the metal screw covers on each door-side hinge section by sliding it down and off.
4. Remove two outer screws that mount each hinge to door, loosen the center screw, rotate hinge 180°, reinstall outer screws and retighten center screw. See Photos 1 and 2.
5. Remove lock strike assembly from the face frame, remove screws from the opposite side of the face frame and install the lock strike. Install the screws removed to fill the original lock strike mounting holes.
6. Pry the plugs out of the hinge mounting holes on the side opposite the current hinge locations and set them aside.
7. Pull the wires for the hinge switch out of the large hole and remove the plastic caps and set them aside to re-use in step 9. See Photo 3.
8. Remove the cabinet hinge screw covers by gently prying them out with a small screwdriver.
9. Remove all three screws from each hinge. Note that one hinge has a hinge actuated switch to operate the lights. Remove the wires from this switch and use the caps removed in step 7 to cap the loose wires. See Photo 3. Move this hinge to the opposite side of the face frame, connect the switch wires and mount the hinge to face frame, then mount the other hinge. Press the plugs removed in step 6 into the screw holes from the original hinge locations. Use a small amount of silicone sealant under the lip of the cap if the fit of the plugs is not tight.
10. Remove the plastic cam from the hinges by pulling straight up, then rotating the cam 180° and pushing back into the hinge.
11. Remount the door and check for proper closure, gasket seal, and light operation. Adjust hinges as needed. Once adjustment is verified, remove the door, reinstall all hinge screw covers and set the door back in place.
12. If additional plugs are needed due to loss or damage, please contact Delfield Parts Department at (800) 733-8821, extension 12801.

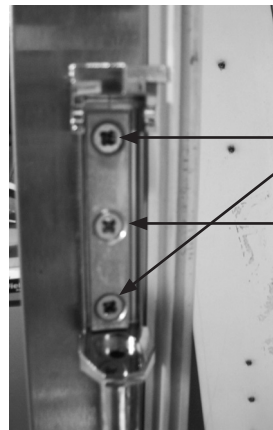

Remove 2 outer screws

Loosen the center screw

Photo 1.



Photo 2. Rotate hinge 180°



Photo 3. Remove the caps and reinstall them on the opposite side switch wires

Maintenance

Door Gasket Maintenance

Door gaskets require regular cleaning to prevent mold and mildew build up and also to retain the elasticity of the gasket. Gasket cleaning can be done with the use of warm soapy water. Avoid full strength cleaning products on gaskets as this can cause them to become brittle and crack. Never use sharp tools or knives to scrape or clean the gasket. Gaskets can be easily replaced and do not require the use of tools or an authorized service person. The gaskets are “Dart” style and can be pulled out of the groove in the door and new gaskets can be “pressed” back into place.

Drain Maintenance - Base

Each unit has a drain located inside the unit that removes the condensation from the evaporator coil and routes it to an external condensate evaporator pan. Each drain can become loose or disconnected during normal use. If you notice water accumulation on the inside of the unit be sure the drain tube is connected to the evaporator drain pan. If water is collecting underneath the unit make sure the end of the drain tube is in the condensate evaporator in the machine compartment. The leveling of the unit is important as the units are designed to drain properly when level. Be sure all drain lines are free of obstructions.

Drawer Maintenance

Drawer Assembly Cleaning

The drawer assembly is designed to be cleaned easily. Both drawer and tracks are removable without tools. The drawer tracks are dishwasher safe or can be cleaned in a sink with detergents and a soft bristle brush. Drawers and tracks should be cleaned on a weekly basis.

Remove Drawers

Pull the drawer box out until it stops. Lift up on the drawer front and pull the drawer box completely out. Using a soft bristle brush, clean the track on the bottom of the drawer box. When finished, it should be wiped clean of all food and debris.

Tracks

The drawer box assembly must be removed. Pull the drawer tracks out until they hit a stop. Locate blue safety clips towards the back of each drawer track. Blue safety clips have a tab on the top. Push the tab back until it clicks. Lift up and pull the

drawer tracks all the way out of the drawer cage. The drawer tracks are dishwasher safe or can be cleaned in a sink with detergents and a soft bristle brush. Drawers

and tracks should be cleaned on a weekly basis. Using a soft bristle brush, wash the track making sure each roller is thoroughly cleaned. The drawer cage should be cleaned with a soft bristle brush, removing any food and debris gathered on the bottom ledge. Once it's cleaned thoroughly with a soft

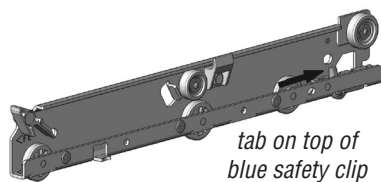

bristle brush, wipe remaining debris clean with a soft towel. Reassembly

Push the drawer tracks into the drawer cage. The blue safety clip must remain pushed towards the back. Lift up and slide the drawer track all the way into the drawer cage. The blue safety clip will lock in place automatically. Once all tracks are replaced, insert the drawer box. Rest the drawer box bottom track on the front track roller. Then push the drawer back in place SLOWLY. When the drawer box is about half way in you will hit a STOP. You must lift the front of the drawer up approximately ½” (1.3cm) to continue inward. Clean tracks as often as possible. The cleaner the tracks are the better they will operate.

Caster Maintenance

Wipe casters with a damp cloth monthly to prevent corrosion.



The power switch must be turned to OFF and the unit disconnected from the power source whenever performing service, maintenance functions or cleaning the refrigerated area.

Refrigerators and Freezers

The interior and exterior can be cleaned using soap and warm water. If this isn't sufficient, try ammonia and water or a nonabrasive liquid cleaner. When cleaning the exterior, always rub with the “grain” of the stainless steel to avoid marring the finish. Do not use an abrasive cleaner because it will scratch the stainless steel and can damage the breaker strips and gaskets.

Stainless Steel Care and Cleaning

To prevent discoloration or rust on stainless steel several important steps need to be taken. First, we need to understand the properties of stainless steel. Stainless steel contains 70-80% iron, which will rust. It also contains 12-30% chromium, which forms an invisible passive film over the steel's surface, which acts as a shield against corrosion. As long as the protective layer is intact, the metal is still stainless. If the film is broken or contaminated, outside elements can begin to breakdown the steel and begin to form discoloration or rust. Proper cleaning of stainless steel requires soft cloths or plastic scouring pads.

NEVER USE STEEL PADS, WIRE BRUSHES OR SCRAPERS!

Cleaning solutions need to be alkaline based or non-chloride cleaners. Any cleaner containing chlorides will damage the protective film of the stainless steel. Chlorides are also commonly found in hard water, salts, and household and industrial cleaners. If cleaners containing chlorides are used be sure to rinse repeatedly and dry thoroughly. Routine cleaning of stainless steel can be done with soap and water. Extreme stains or grease should be cleaned with a non-abrasive cleaner and plastic scrub pad. Always rub with the grain of the steel. There are stainless steel cleaners available which can restore

Maintenance, continued

and preserve the finish of the steels protective layer. Early signs of stainless steel breakdown are small pits and cracks. If this has begun, clean thoroughly and start to apply stainless steel cleaners in attempt to restore the passivity of the steel.



Never use an acid based cleaning solution! Many food products have an acidic content, which can deteriorate the finish. Be sure to clean the stainless steel surfaces of ALL food products. Common items include, tomatoes, peppers and other vegetables.

Cleaning the Condenser Coil

In order to maintain proper refrigeration performance, the condenser fins must be cleaned of dust, dirt and grease regularly. It is recommended that this be done at least every three months. If conditions are such that the condenser is totally blocked in three months, the frequency of cleaning should be increased. Clean the condenser with a vacuum cleaner or stiff brush. If extremely dirty, a commercially available condenser cleaner may be required.

Failure to maintain a clean condenser coil can initially cause high temperatures and excessive run times. Continuous operation with a dirty or clogged condenser coil can result in compressor failure. Neglecting the condenser coil cleaning procedures will void any warranties associated with the compressor and cost to replace the compressor.



Never use a high-pressure water wash for this cleaning procedure as water can damage the electrical components located near or at the condenser coil.

Doors/Hinges

Over time and with heavy use doors the hinges may become loose. If this happens tighten the screws that mount the hinge brackets to the frame of the unit. Loose or sagging doors can cause the hinges to pull out of the frame, which may damage both the doors and the hinges. In some cases this may require qualified service agents or maintenance personnel to perform repairs.



Do not place hot pans on/against the grey ABS door liner. Do not throw items into the storage area. Failure to follow these recommendations could result in damage to the interior of the cabinet or to the blower coil. Overloading the storage area, restricting the airflow, and continuous opening and closing of the doors and drawers will hamper the units ability to maintain operational temperature.

Preventing blower coil corrosion

To help prevent corrosion of the blower coil, store all acidic items, such as pickles and tomatoes, in sealable containers.

Immediately wipe up all spills.

Continuous opening and closing of the doors will hamper the unit's ability to maintain optimum refrigeration temperature.

Fluorescent Light Bulb Replacement

Delfield recommends that fluorescent light bulbs be recycled rather than disposed of.

Wiring Diagram Specification Line Refrigerators

S_R1, S_R1N, S_R1S, S_RPT1, S_RPT1S, S_RRI1, S_RRT1, SSRFF1 - Solid Doors

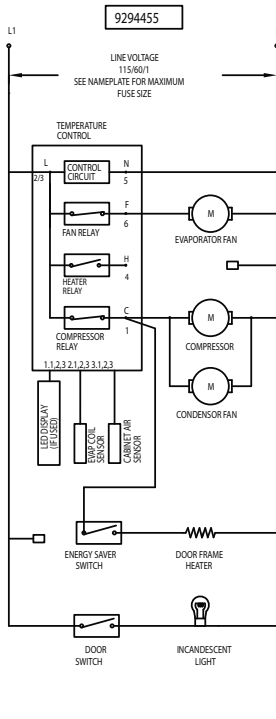

- NOTES:
 1) USE COPPER CONDUCTORS ONLY
 2) THIS UNIT MUST BE GROUNDED
 3) UNIT SHOWN WITH COMPRESSOR RUNNING AND DOORS CLOSED

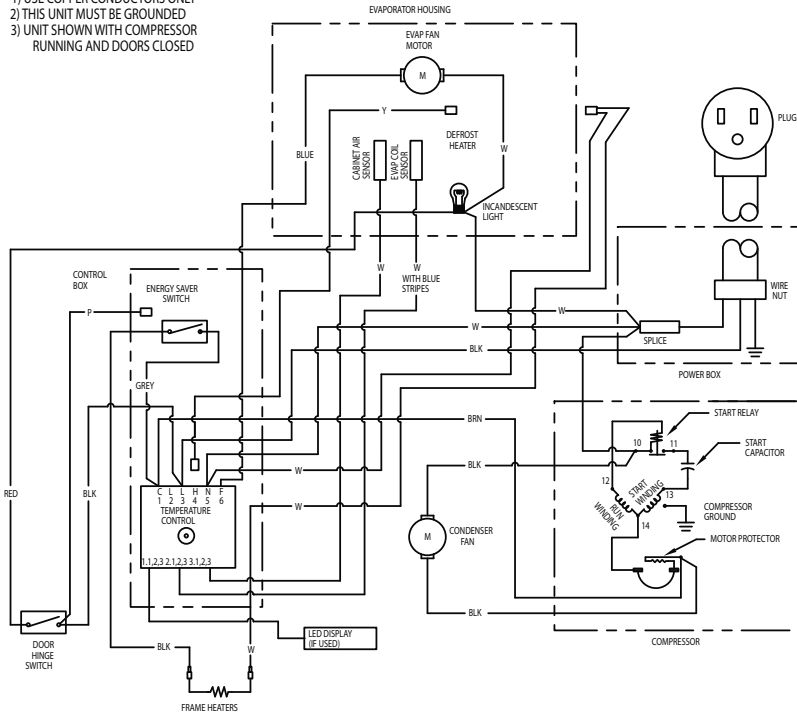

S_R1, S_R1N, S_R1S, S_RPT1, S_RRI1 - Glass Doors

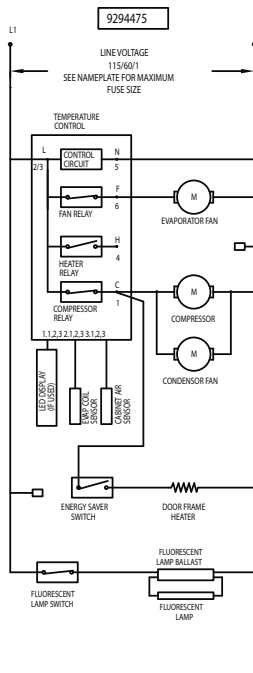

- NOTES:
 1) USE COPPER CONDUCTORS ONLY
 2) THIS UNIT MUST BE GROUNDED
 3) UNIT SHOWN WITH COMPRESSOR RUNNING AND DOORS CLOSED

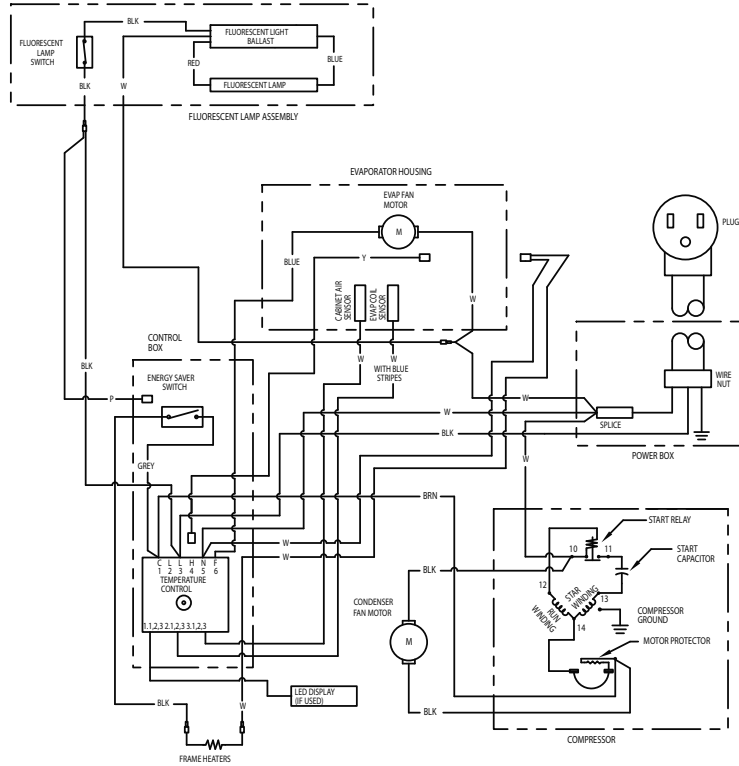

Wiring Diagram Specification Line Refrigerators

S_R2, S_R2N, S_R2S, S_R2-SL, S_R2S-SL, S_RPT2S, S_RRI2, SSRFF2 - Solid Doors

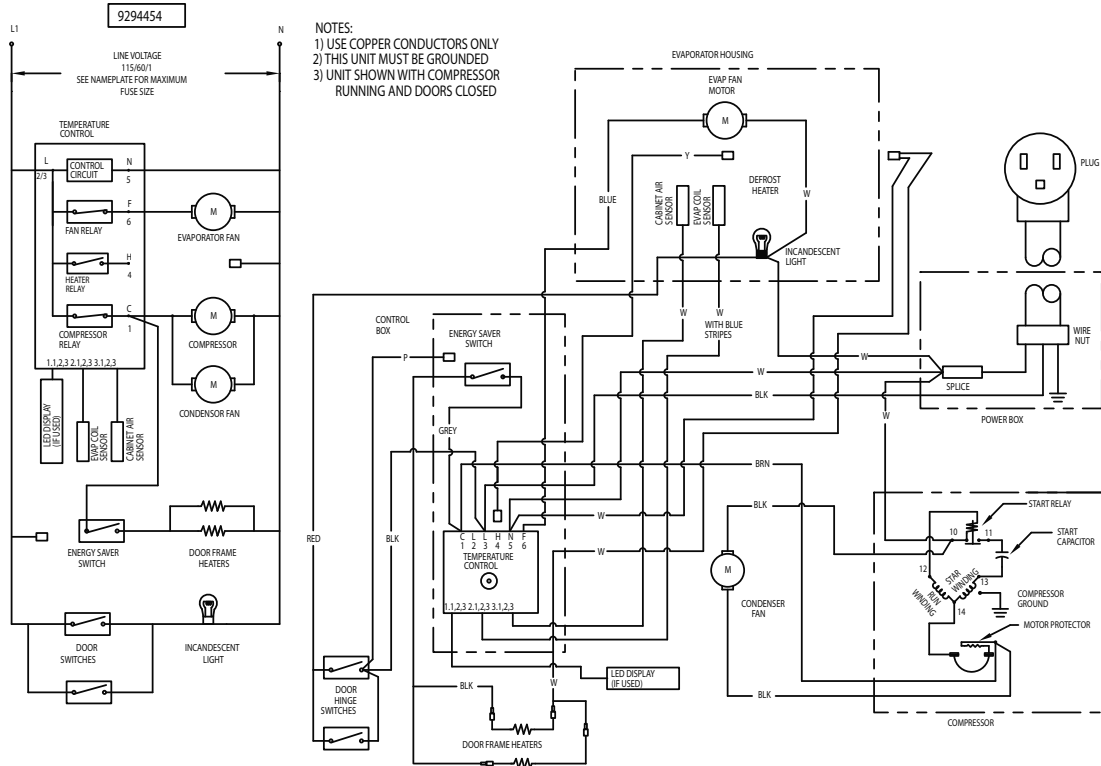

S_R2, S_R2N, S_R2S, S_R2-SL, S_R2S-SL - Glass Doors

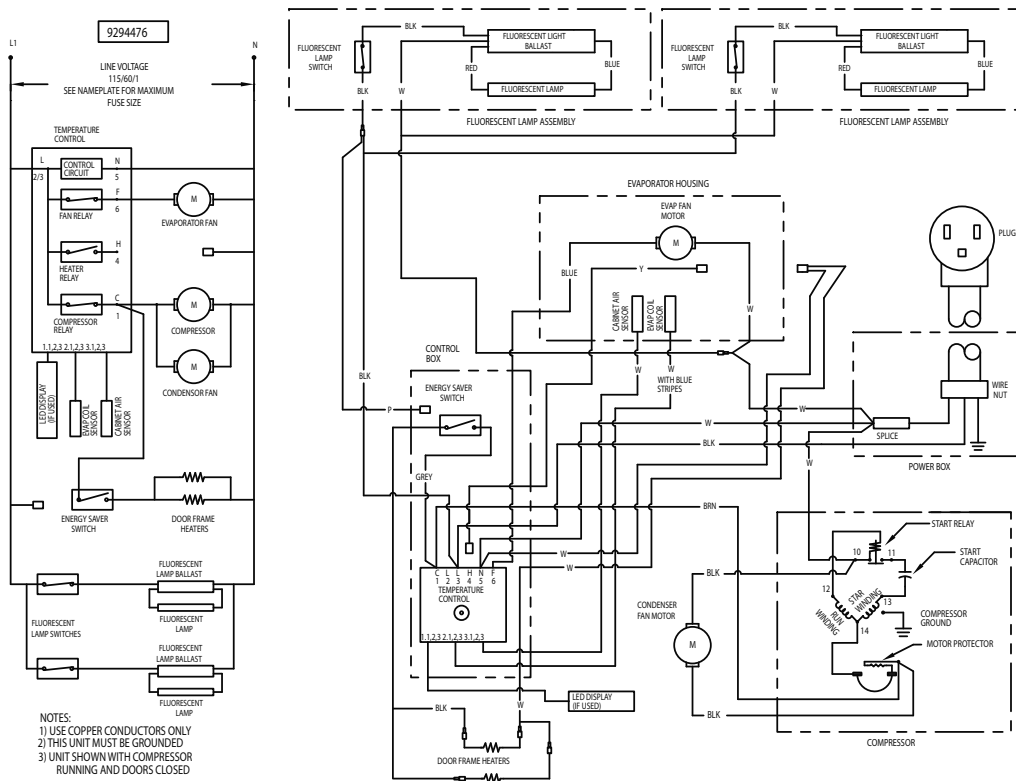

Wiring Diagram Specification Line Refrigerators

S_RPT2, S_RRT2, S_R3, S_RRI3 - Solid Doors

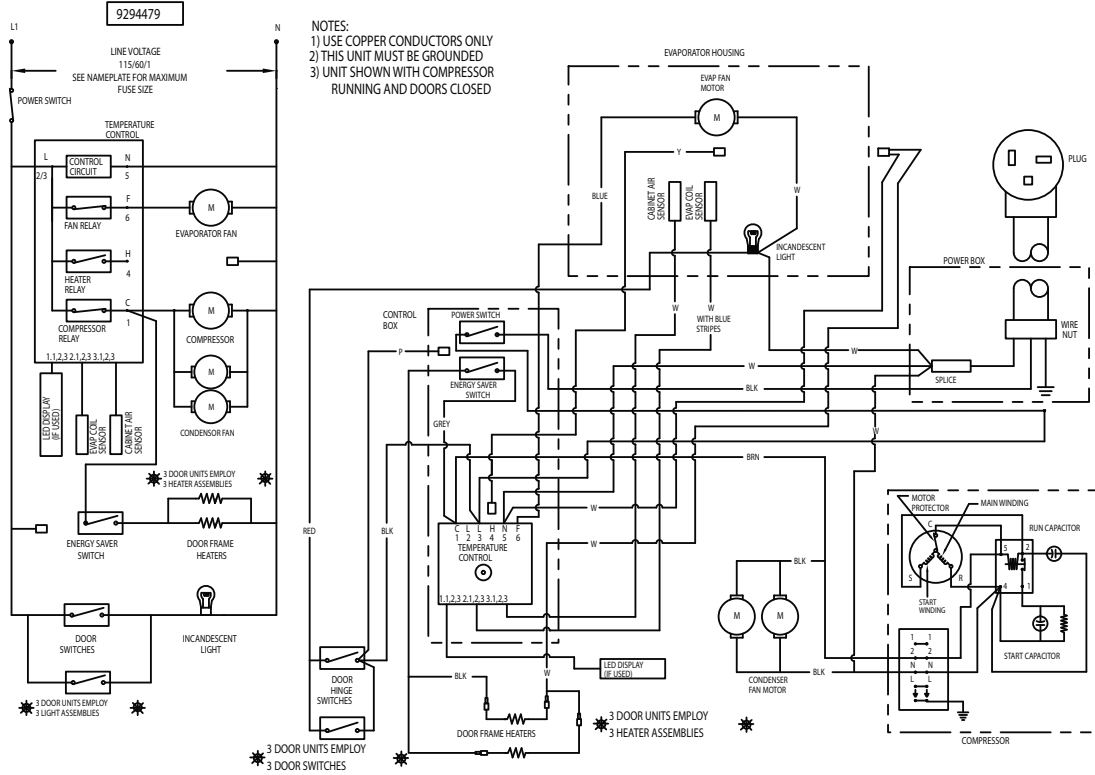

S_RPT2, S_RRI2, S_R3 - Glass Doors

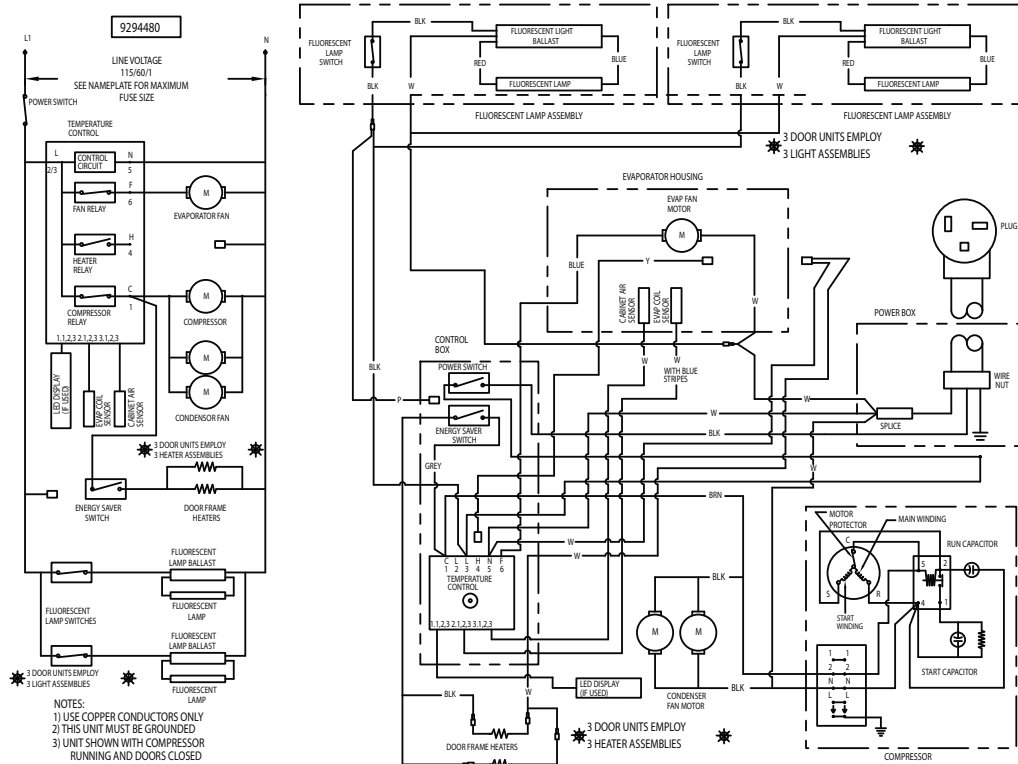

Wiring Diagram Specification Line Freezers

S_F1, S_F1N, S_F1S - Solid Doors

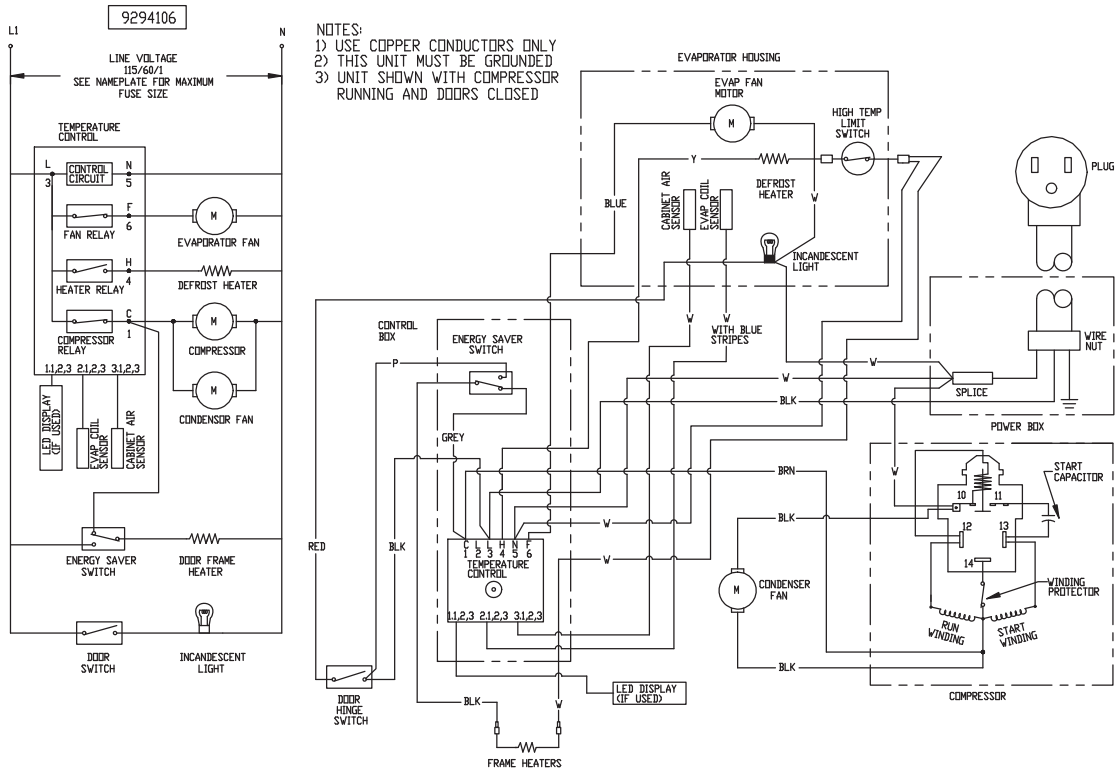

S_F1 - Glass Doors

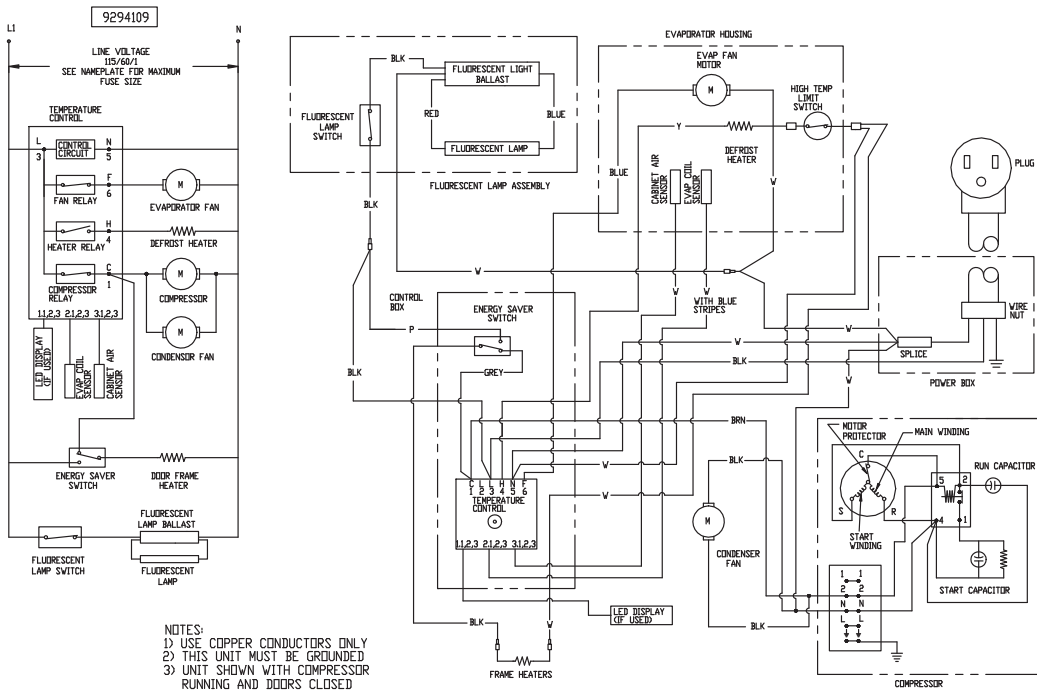

Wiring Diagram Specification Line Refrigerator/Freezer Combinations

S_DTR1, S_DBR1 - Solid & Glass Doors

- NOTES:
 1) USE COPPER CONDUCTORS ONLY
 2) THIS UNIT MUST BE GROUNDED
 3) UNIT SHOWN WITH COMPRESSOR RUNNING AND DOORS CLOSED

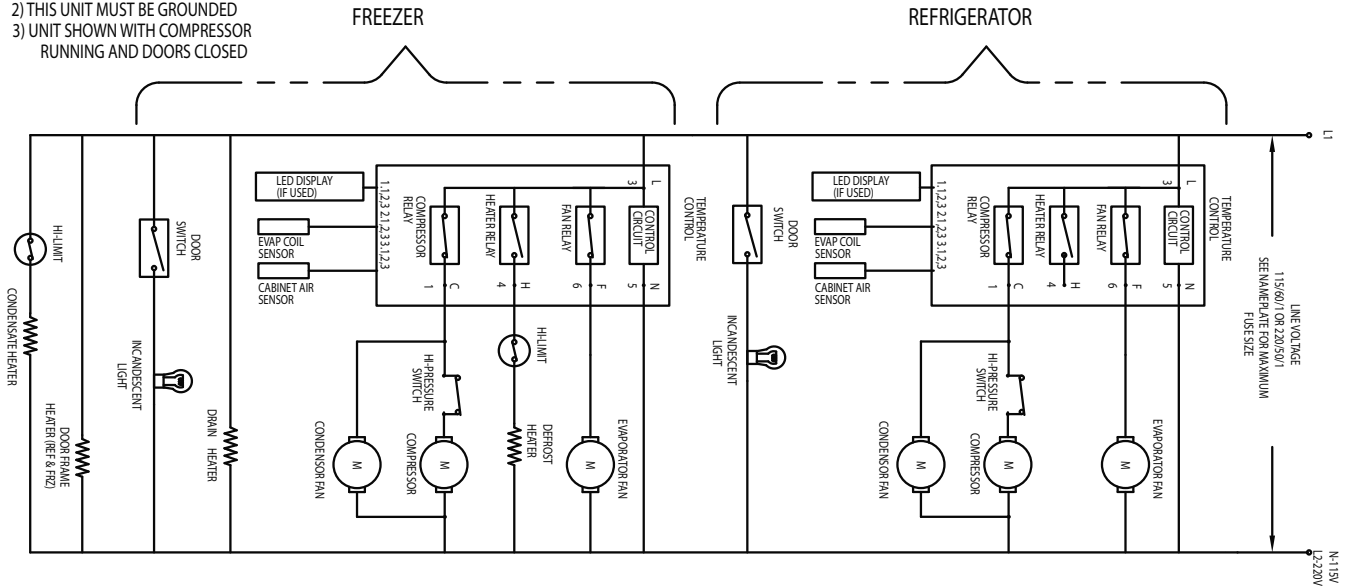

S_DRL2, S_DFL2 - Solid & Glass Doors S_DRP2, S_DFP2 - Solid Doors

- NOTES:
 1) USE COPPER CONDUCTORS ONLY
 2) THIS UNIT MUST BE GROUNDED
 3) UNIT SHOWN WITH COMPRESSOR RUNNING AND DOORS CLOSED

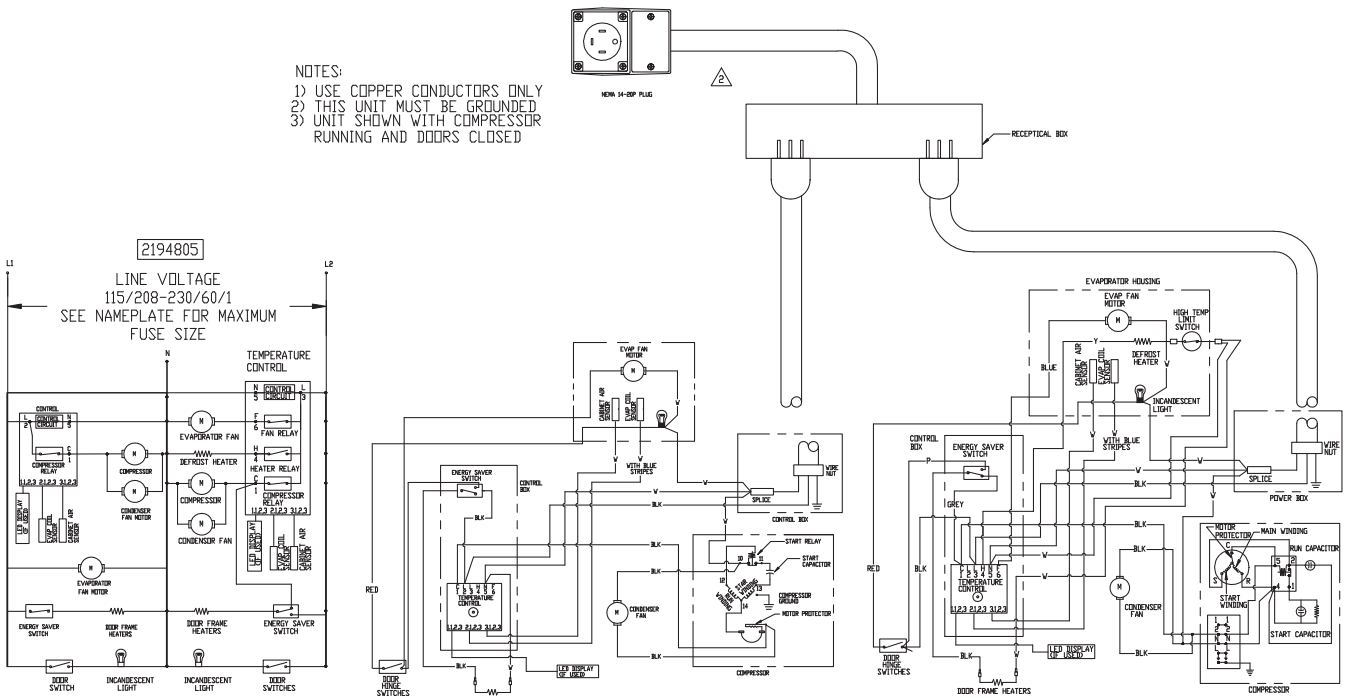

Wiring Diagram Specification Line Heated Models

S_H1, S_H2, S_HRI1, S_HRI2 - Solid & Glass Doors

S_H2N, S_HPT1, S_HPT2, S_HRT1, S_HRT2 - Solid Doors

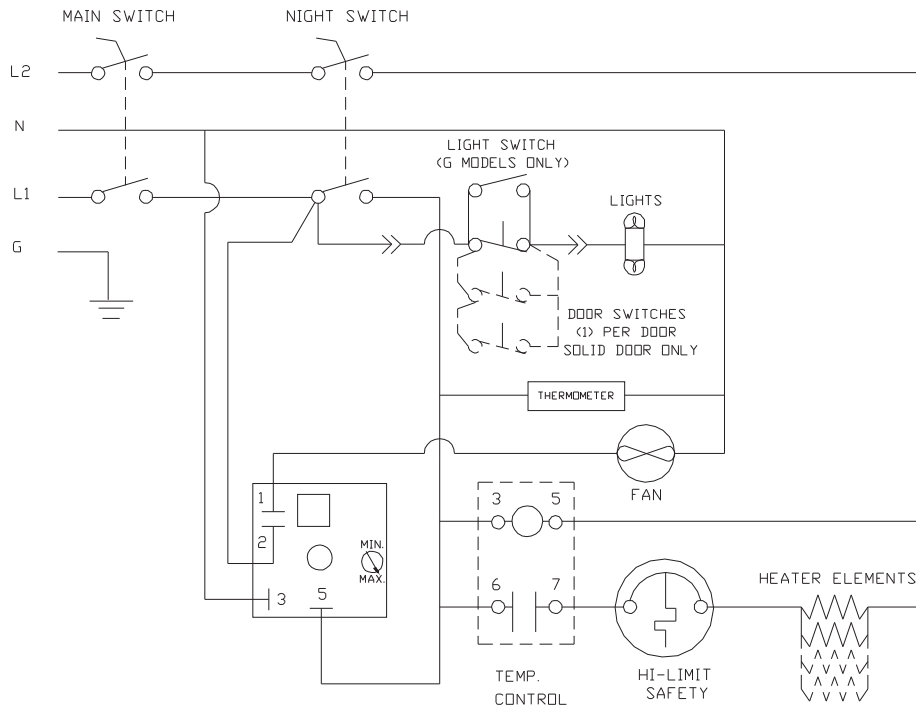

WIRING DIAGRAM - 115/208-230V SPECIFICATION LINE HEATED

S_H3, SSHRI3 - Solid & Glass Doors

S_HRT3 - Solid Doors

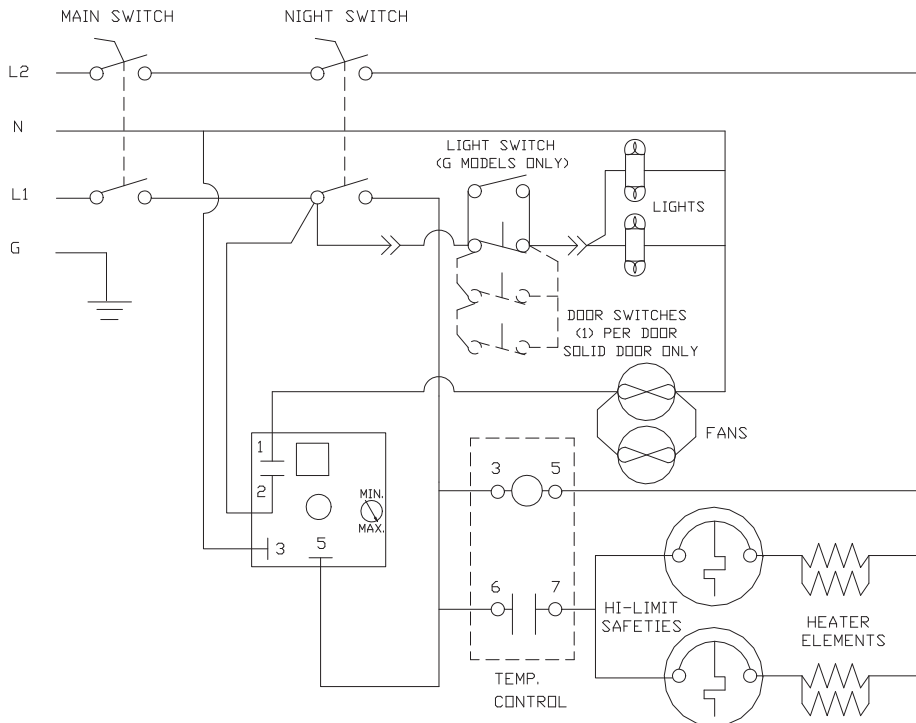

Compressor Diagrams

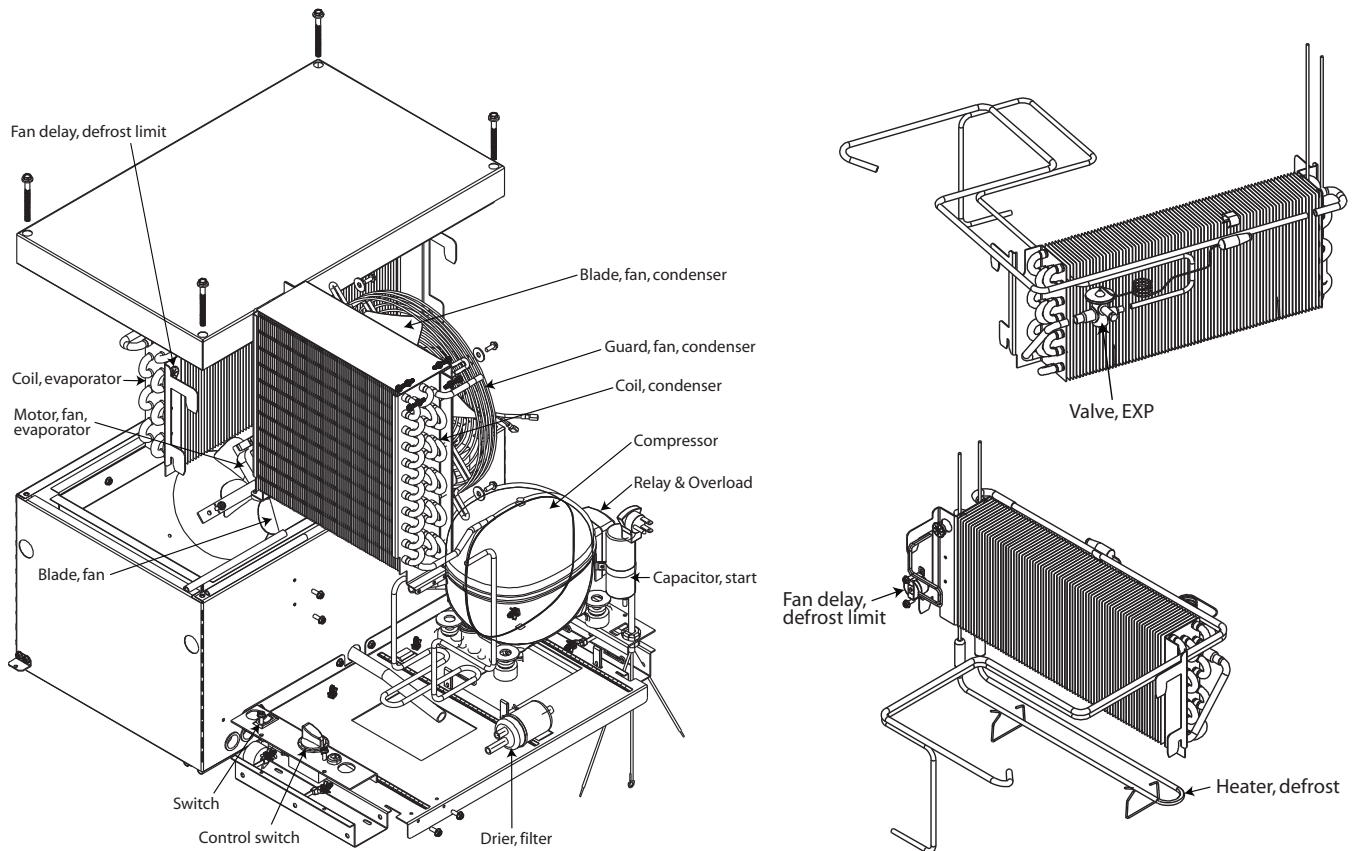
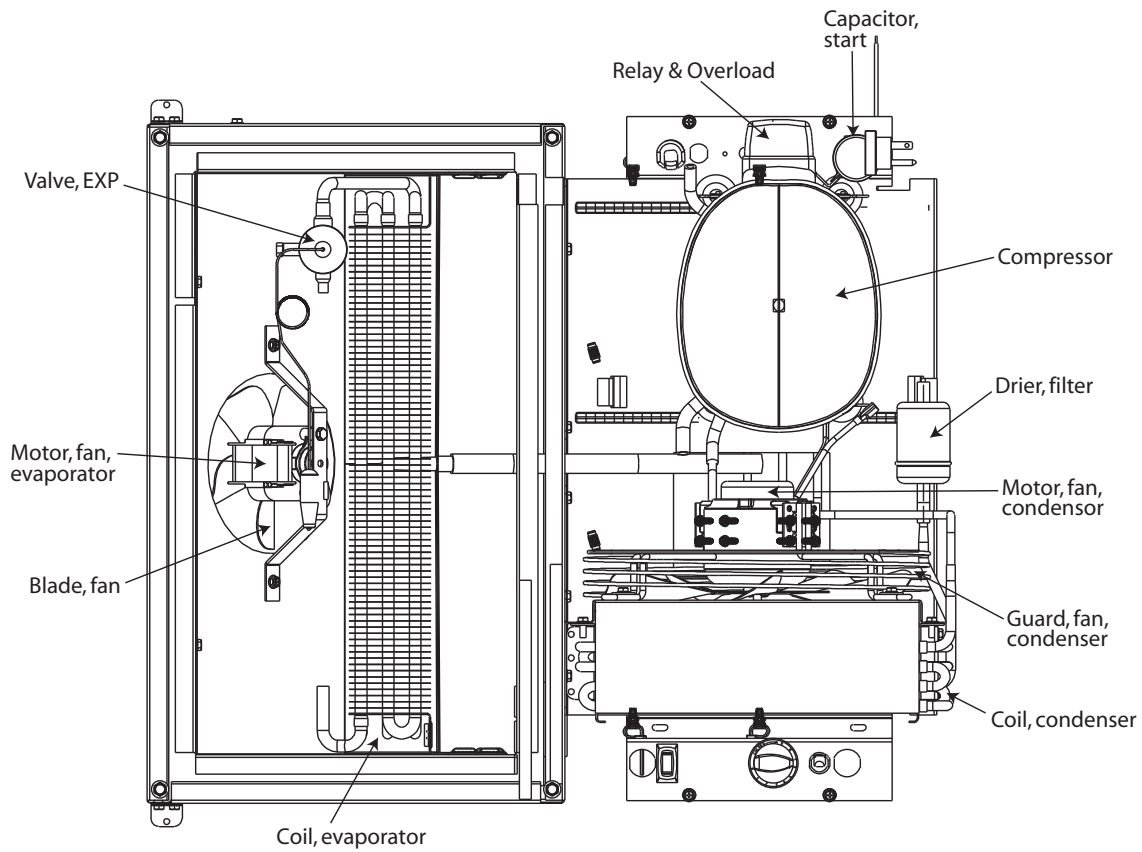

Replacement Parts

S_R1, S_R1N, S_R1S, S_RPT1, S_RPT1S, SSRFF1, S_RRI1, S_DRL2, S_DFL2, S_DRP2, S_DFP2 - Solid Doors
S_R1, S_R1N, S_R1S, S_DRL2, S_DFL2 - Glass Doors

Part Number	Description
2194792	Display, Blue, Danfoss
3516432	Blade, Fan, 25Deg, 8.75"
3517390	Blade, Fan, 5.56, CW, Lexan
3516204A	Breaker, Vacuum
2194791	Cable, Display, 59
2194787	Capacitor, Start, 280MFD
3516427	Coil, Condenser, Large, Upright
3516437	Coil, Evap, Ref, 1DR
3526999	Comp, NF5.5CLX, 115V, 60HZ
3516444	Comp, Relay, Ovid, NF5.5CLX
2194811	Control, GDM, Danfoss, 115V
3516322	Drier, Filter, (2)Inlet
2160019	Guard, Fan, Wire
2162717	Motor, Fan, 9W, 115V, CW
2162715	Motor, Fan, Bay, 3/4ST
2190154	Switch, SPST, Rocker, 20A/125V
3516429	Valve, Therm EXP, W/O MOP

S_R2, S_R2N, S_R2-SL, SSRFF2, S_RRI2 - Solid Doors
S_R2, S_R2N, S_R2-SL - Glass Doors

Part Number	Description
2194792	Display, Blue, Danfoss
3516433	Blade, Fan, 25
3516204A	Breaker, Vacuum
2194791	Cable, Display, 59
2194788	Capacitor, Start, 320MFD
3517343	Coil, Condenser, Small
3517341	Coil, Evap, Sml Ref, 2dr, Up
3527000	Comp, NF7.0, 115V/60HZ
2194811	Control, GDM, Danfoss, 115V
3516322	Drier, Filter, (2)Inlet
2160019	Guard, Fan, Wire
2162750	Motor, Fan, Evap, PSC
2162716	Motor, Fan, Cond
3516438	Relay, Comp, Ovid, NF7CLX
2190154	Switch, SPST, Rocker, 20A/125V
3516429	Valve, Therm EXP, W/O MOP

S_R2S, S_R2S-SL, S_RRT1 - Solid Doors
S_R2S, S_R2S-SL, S_RPT1, S_RRI1 - Glass Doors

Part Number	Description
2194792	Display, Blue, Danfoss
3516433	Blade, Fan, 25
3517390	Blade, Fan, 5.56, CW, Lexan
3516204A	Breaker, Vacuum
2194791	Cable, Display, 59
2194788	Capacitor, Start, 320MFD
3516427	Coil, Condenser, Large
3516437	Coil, Evap, Ref, 1DR
3527000	Comp, NF7.0, 115V/60HZ
2194811	Control, GDM, Danfoss, 115V
3516322	Drier, Filter, (2)Inlet
2160019	Guard, Fan, Wire
2162716	Motor, Fan, 16W, 115V, CW
2162750	Motor, Fan, PSC
3516438	Relay, Comp, Ovid, NF7CLX
2190154	Switch, SPST, Rocker, 20A/125V
3516429	Valve, Therm EXP, W/O MOP

S_R3, S_RPT2, S_RPT2S, S_RRI3, S_RRT2 - Solid Doors
S_R3, S_RPT2, S_RRI2 - Glass Doors

Part Number	Description
3516433	Blade, Fan, 25
3516204A	Breaker, Vacuum
2194791	Cable, Display, 59
3516468	Capacitor, Start, Run, Assy
3517344	Coil, Condenser, Lrg 2dr
3517341	Coil, Evap, Sml Ref, 2dr, Up
3527016	Comp, SC15MLX.2, 115V/60HZ
2194811	Control, GDM, Danfoss, 115V
2194792	Display, Blue, Danfoss
3517345	Drier, Filter, 3/8", Danfoss
2160019	Guard, Fan, Wire
2162750	Motor, Fan, Evap, PSC
2162716	Motor, Fan, Cond
2190154	Switch, SPST, Rocker, 20A/125V
3516557	Valve, Thermal, Expansion

Replacement Parts, continued

S_F1, S_F1N, S_F1S, S_DRL2, S_DFL2 - Solid Doors S_DRL2, S_DFL2 - Glass Doors

<i>Part Number</i>	<i>Description</i>
3516432	Blade, Fan, 25DEG, 8.75"
3517390	Blade, Fan, 5.56, CW, Lexan
3516204A	Breaker, Vacuum
2194791	Cable, Display, 59
2194789	Capacitor, Start, 240MFD
3516427	Coil, Condenser, Large, Upright
3516436	Coil, Evap, Frz, 1DR
3527001	Comp, SC12CLX.2, 115/60HZ
2194812KT	Control, Frz, Danfoss
2194792	Display, Blue, Danfoss
3516322	Drier, Filter, (2)Inlet
2160019	Guard, Fan, Wire
2194785	Htr, Def, 400W, 115V, 1DR
2194953	Limit, High Defrost
2162717	Motor, Fan, 9W, 115V, CW
2162715	Motor, Fan, Bay, 3/4ST
3516441	Relay, Comp, SC12CLX.2
2194959	Switch, SPDT, Rocker, Snap-in
3516588	Valve, Therm Exp, W/O MOP

S_F2, S_F2N - Solid Doors

<i>Part Number</i>	<i>Description</i>
3516433	Blade, Fan, 25
3516204A	Breaker, Vacuum
2194791	Cable, Display, 59
3516468	Capacitor, Start, Run, Assy
3517340	Coil, Evap, Sml FRZ, 2dr, Up
3527002	Comp, SC18CLX.2
2194812KT	Control, Frz, Danfoss
2194792	Display, Blue, Danfoss
3516322	Drier, Filter, (2)Inlet
2160019	Guard, Fan, Wire
2194970	Heater, Defrost, 600W, 115V
2194953	Limit, High Defrost
2162750	Motor, Fan, PSC
2194959	Switch, SPDT, Rocker, Snap-in
2190154	Switch, SPST, Rocker, 20A/125V
3516557	Valve, Thermal, Expansion

S_FPT1, S_FRI1, S_F2S, S_DRP2, S_DFP2 - Solid Doors S_F1 - Glass Doors

<i>Part Number</i>	<i>Description</i>
3516433	Blade, Fan, 25
3517390	Blade, Fan, 5.56, CW, Lexan
3516204A	Breaker, Vacuum
2194791	Cable, Display, 59
3516468	Capacitor, Start, Run, Assy
3516427	Coil, Condenser, Large
3516436	Coil, Evap, Frz, 1DR
3527002	Comp, SC18CLX.2
2194812KT	Control, Frz, Danfoss
2194792	Display, Blue, Danfoss
2160019	Guard, Fan, Wire
2194785	Htr, Def, 400W, 115V, 1DR
2194953	Limit, High Defrost
2162716	Motor, Fan, 16W, 115V, CW
2162750	Motor, Fan, PSC
2194959	Switch, SPDT, Rocker, Snap-in
2190154	Switch, SPST, Rocker, 20A/125V

S_F3, S_FRI2 - Solid Doors S_F2 - Glass Doors

<i>Part Number</i>	<i>Description</i>
3516433	Blade, Fan, 25
3516204A	Breaker, Vacuum
2194791	Cable, Display, 59
2194979	Capacitor, Run, 45 MFD
2194978	Capacitor, Start, 145-175
3517344	Coil, Condenser, Lrg 2dr
3517342	Coil, Evap, Lrg Frz, 2dr
3527017	Comp, AWA2460ZXD, 208V/60H
2194974	Contact, 2 Pole, 120V
2194812KT	Control, Frz, Danfoss
2194792	Display, Blue, Danfoss
2160019	Guard, Fan, Wire
2194970	Heater, Defrost, 600W, 115V
2194953	Limit, High Defrost
2162750	Motor, Fan, PSC
2194980	Relay, Potential, Start
2194959	Switch, SPDT, Rocker, Snap-in
3516557	Valve, Thermal, Expansion

Shelf Replacement Parts

S_DTR1, S_DBR1 - Solid & Glass Doors

Part Number	Description
3516172	Blade, Fan, 5.56, CCW
3516432	Blade, Fan, 25deg, 8.75", CW
3516427	Coil, Condenser, Large, Upright
3516239	Coil, Evap, Refrig., RT, Spec
3516220	Coil, Evap, Frz, RT, Spec
3526999	Compressor, Frz., NF5.5CLX, 115V, 60Hz
3526997	Compressor, Ref., TF4CLX
3516443	Compressor Cover, Frz/Ref, Small, Danfoss
2194783-5KT	Control, Frz, Danfoss, ETC1H, 115V
2194783-6KT	Control, Ref, Danfoss, ETC1H, 115V
3516322	Drier, Filter, (2)inlet 1/4"
2160019	Guard, Fan, Wire
3516173	Guard, Plastic, Fan, 6
3978197	Guard, Wire, Evaporator
2194659	Heater, 115V-100W, 1A
2194670	Heater, 115V-305W, 3A
2194679	Heater, Drain, 120V-3.75W
2162717	Motor, Fan, 9W, 115V, CW
2162691	Motor, Fan, 115V, 50/60
3516446	Relay, Comp, Ref., Danfoss P/N 117U4148
3516444	Relay, OVLD, Comp, Frz, NF5.5CLX
2194787	Start, Capacitor, Frz/Ref, 280MFD
3516331	Switch, High Press, 1/4"Tube, 404A, 450
3517394	Valve, Exp, R404A, Frz, 1/4
3517393	Valve, Exp, R404A, Ref, 1/4

All Heated Models

Part Number	Description
000-C1A-0048-S	Blower Motor Service Kit
2194377	Control Knob
2194645	Heating, Elem, Fin, 900W
2194618	Relay, Timer, 120V, 1HP
2194370	Sensor, Temp, Htd Cab
2194409	Switch, Rocker, 20A, 2HP
3516330	Thermometer, 120V Dig, TI
000-C1A-0001	Thermostat, Hi-Limit
2194372	Thermostat, Htd Cabinet

Model	Shelf Number
S_R1-S, SH, G, GH S_R2-S, SH, G, GH S_RPT1-S, SH, G, GH S_DTR1-SH, GH S_DBR1-SH, GH S_DRL2-S, SH, G, GH S_DFL2-S, SH, G, GH S_DRP2-S, SH, S_DFP2-S, SH S_R2-SLS, SLSH, SLG, SLGH S_R3-S, SH, G, GH S_RPT2-S, SH, G, GH S_F1-S, SH, G, GH S_F2-S, SH, G, GH S_F3-S, SH S_FPT1-S, SH	3978170
S_H1-S, SH, G, GH S_H2-S, SH, G, GH S_H3-S, SH, G, GH S_HPT1-S, SH S_HPT2-S, SH	3978171
S_R1N-S, SH, G, GH S_R2N-S, SH, G, GH S_F1N-S, SH S_F2N-S, SH	3978172
S_H2N-S, SH	3978173
S_R1S-S, SH, G, GH S_R2S-S, SH, G, GH S_R2S-SLS, SLSH, SLG, SLGH S_RPT1S-S, SH S_RPT2S-S, SH S_F1S-S, SH S_F2S-S, SH	3978174
All Models	3234617KT Hinge, 1-5/16" Offset with adjustable housing
All Models	3234782 Shelf Clip, SS

Standard Labor Guidelines To Repair Or Replace Parts On Delfield Equipment

Advice and recommendations given by Delfield Service Technicians do not constitute or guarantee any special coverage.

- A maximum of 1-hour is allowed to **diagnose a defective component**.
- A maximum of 1-hour is allowed for **retrieval of parts** not in stock.
- A maximum **travel distance** of 100 miles round trip and 2-hours will be reimbursed.
- Overtime, installation/start-up, normal control adjustments, general maintenance, glass breakage, freight damage, and/or correcting and end-user installation error will not be reimbursed under warranty unless pre-approved with a **Service Work Authorization** from Delfield. You must submit the number with the service claim.

Labor Of 1-Hour Is Allowed To Replace:

- Thermostat
- Door Jamb Switch
- Solenoid Coil
- Hi-limit/Thermal Protector Switch
- Fan Delay/Defrost Termination Switch
- Compressor Start Components and Overload Protector
- Defrost Timer
- Thermometer
- Contactor/Relay
- Evaporator/Condenser Fan Motor and Blade
- Circulating Fan Motor and Blade
- Microprocessor Control
- Transformer
- Door Hinges, Locks, and Gaskets
- Condensate Element

Labor Of 2 Hours To Replace:

- Drawer Tracks/Cartridges
- Pressure Control
- Solenoid Valve
- Defrost Element
- Heating Element
- Locate/Repair Leak

Labor Of 3 Hours To Replace:

- EPR or CPR Valve
- Expansion Valve
- Condenser or Evaporator Coil

Labor Of 4 Hours To Replace:

- Compressor

This includes recovery of refrigerant and leak check.

\$55.00 maximum reimbursement for refrigerant recovery (includes recovery machine, pump, torch, oil, flux, minor fittings, solder, brazing rod, nitrogen, or similar fees.)

Refrigerants:

- R404A A maximum of \$15.00/lb. or \$1.00/oz. will be reimbursed.

Notes

Notes



Mt. Pleasant, MI



Covington, TN

Thank you for choosing Delfield!

Help is a phone call away. Help our team of professional, courteous customer service reps by having your model number and serial number available at the time of your call (800) 733-8829.

Model: _____ S/N: _____

Installation Date: _____



For a list of Delfield's authorized parts depots, visit our website at www.delfield.com

Register your Delfield warranty online. Go to www.delfield.com under the service tab to complete.

