

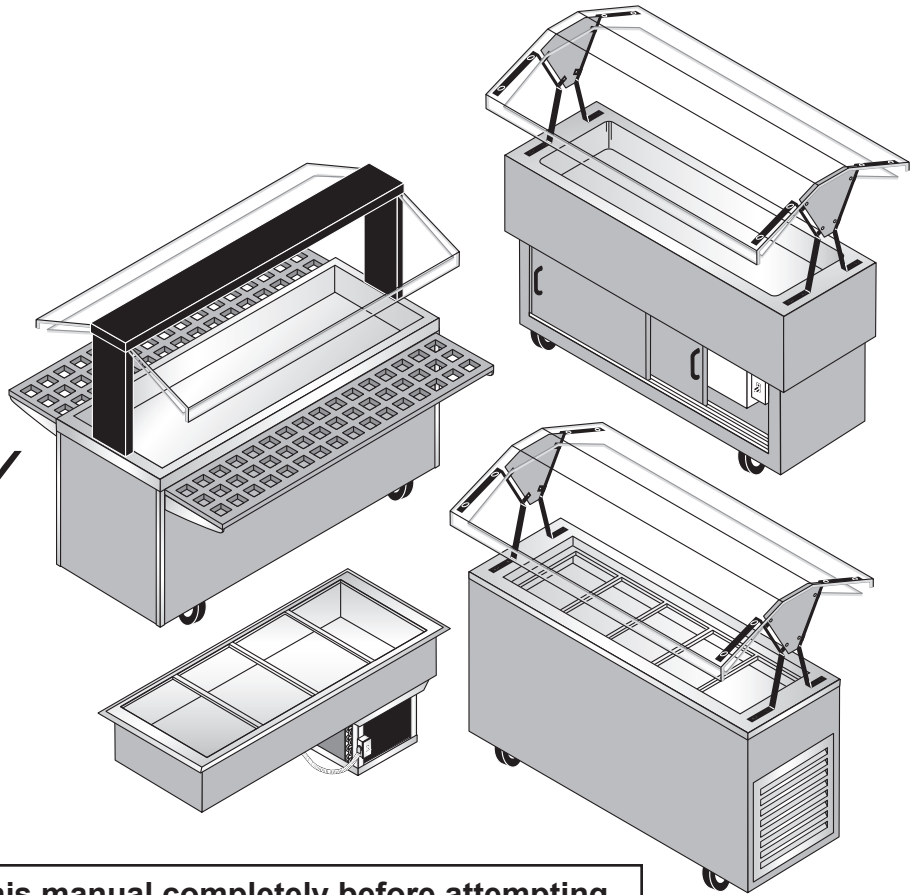

Service Manual

MECHANICALLY COOLED BUFFETS AND SALAD BARS



Please read this manual completely before attempting to install, operate or service this equipment

This document is prepared for trained Duke service technicians. It is not to be used by anyone not properly qualified to perform these procedures.

This Service Manual is not all encompassing. If you have not been trained on servicing this product, be sure to read the manual completely before attempting servicing. Be sure all necessary tools, test equipment, and skills are available. Those procedures for which you do not have the proper skills and test equipment must be performed only by a qualified Duke trained service technician.

This manual is copyright ©2011 Duke Manufacturing Company. All rights reserved. Reproduction without written permission is prohibited. Duke is a registered trademark of the Duke Manufacturing Company.

Duke Manufacturing Company

2305 N. Broadway • St. Louis, MO 63102

800.735.3853 • 314.231.1130

Fax: 314-231-5074

www.dukemfg.com

IMPORTANT WARNING AND SAFETY INFORMATION

WARNING

READ THIS MANUAL THOROUGHLY BEFORE OPERATING, INSTALLING, OR PERFORMING MAINTENANCE ON THE EQUIPMENT.

WARNING

FAILURE TO FOLLOW INSTRUCTIONS IN THIS MANUAL CAN CAUSE PROPERTY DAMAGE, INJURY OR DEATH.

WARNING

DO NOT STORE OR USE GASOLINE OR OTHER FLAMMABLE VAPORS OR LIQUIDS IN THE VICINITY OF THIS OR ANY OTHER APPLIANCE.

WARNING

DO NOT OPERATE THIS EQUIPMENT WITHOUT PROPERLY PLACING AND SECURING ALL COVER AND ACCESS PANELS.

CAUTION

Observe the following:

- Provide and maintain adequate minimum clearances from all walls and combustible materials.
- Provide and maintain adequate clearance for air openings.
- Keep the equipment area free and clear of combustible material.
- Operate equipment only on the type of electricity indicated on the specification plate.
- Retain this manual for future reference.

TABLE OF CONTENTS

MECHANICALLY ASSISTED COLD PAN SPECIFICATIONS	4
INSTALLATION	4
LOCATION.....	4
LEVELING	4
STABILIZING	4
ELECTRICAL CONNECTION	4
PARTS REMOVAL AND REPLACEMENT PROCEDURES	5
THERMOSTAT REPLACEMENT.....	5
POWER ON/OFF SWITCH	5
EVAPORATOR	6
REFRIGERATION SYSTEM REPLACEMENT.....	6
DRAIN REPLACEMENT.....	6
PLEXIGLAS CANOPY REPLACEMENT.....	7
ECONOMATE AND AEROHOT SALAD BARS	7
CASTER REPLACEMENT	8
Economate.....	8
Heritage, Thurmaduke & AHC Duke Salad Bar Models	8
RECHARGING REFRIGERATION SYSTEM.....	9
TOOLS.....	9
CHARGING PROCEDURE	9
TROUBLESHOOTING PROCEDURE	10
MAINTENANCE	10
STAINLESS STEEL CARE AND CLEANING	10
CARE AND CLEANING: PAINTED OR POWDER COATED UNITS	11
CLEANING THE CONDENSER COIL.....	11

MECHANICALLY ASSISTED COLD PAN SPECIFICATIONS

MODEL	DESCRIPTION	VOLTAGE	HEIGHT	WIDTH
HB3CM – HB5CM	Heritage	120VAC & 220VAC	36"	24 ½"
HB3CM-N7 – HB5CM-N7	Heritage – NSF Standard 7	120VAC & 220VAC	36"	24 ½"
315-25 – 316-25 & 327-25	AeroServ	120VAC & 220VAC	36"	24 ½"
31525N7 – 31625N7 & 32725N7	AeroServ – NSF Standard 7	120VAC & 220VAC	36"	24 ½"
TCM-32, 46, 60, 74 & 88	Thurmaduke Serving System	120VAC & 220VAC	36"	32"
TCM -32, 46, 60, 74 & 88-N7	Thurmaduke Serving System – NSF Standard 7	120VAC & 220VAC	36"	32"
NG32, 46, 60, 74C	Next Generation 5" Deep	120VAC	36"	32 ¾"
NG32, 46, 60, 74CP	Next Generation 8" Deep	120VAC	36"	32 ¾"
NG32, 46, 60, 74C7	Next Generation 8"Deep – NSF Standard 7	120VAC	36"	32 ¾"
NG32, 46, 60, 74CP7	Next Generation 10" Deep – NSF Standard 7	120VAC	36"	32 ¾"
AHC-5M – 7M	Duke Salad Bar	120VAC & 220VAC	36"	24 ½"
AHC-5M – 7M-N7	Duke Salad Bar – NSF Standard 7 Cold Pan	120VAC & 220VAC	36"	24 ½"

Note: Table does not include canopy dimensions.

INSTALLATION

LOCATION

The unit represented in this manual is intended for indoor use only. Be sure the chosen location has a floor strong enough to support the total weight of the unit. Reinforce the floor if necessary to provide for maximum loading. For the most efficient operation, be sure to provide good air circulation inside and out.

LEVELING

Be sure that the units are placed on a firm, flat surface/floor. Check for cracks in flooring or tile and avoid these areas if possible. If necessary place support pads, properly rated for the weight of the unit, to “bridge” uneven or cracked flooring. Use the adjustable legs to level unit properly.

STABILIZING

Use the leg adjustments to insure that the unit is solid to the floor surface at all four contact points. Insure that the unit does not “rock” when pressure is applied to the top corners.

Locking casters are provided on portable models. Stabilize the unit by placing spacers between one of the locking casters and the floor until the unit is firm at all four corners. Make sure the casters are locked whenever the unit is in service.

ELECTRICAL CONNECTION

Most cold pan models are available as a 120VAC, 60 Hz or as a 220VAC, 50 Hz. Check the model specifications for the correct power source. All electrical connections must be performed by a certified electrician and must comply with local electrical codes for the municipality.



WARNING

REFER TO THE AMPERAGE DATA LIST IN THE SPECIFICATIONS OR THE SERIAL TAG DATA AND YOUR LOCAL CODE OR THE NATIONAL ELECTRICAL CODE TO BE SURE UNIT IS CONNECTED TO THE PROPER POWER SOURCE. A PROTECTED CIRCUIT OF THE CORRECT VOLTAGE AND AMPERAGE MUST BE RUN FOR CONNECTION OF THE SUPPLY CORD OR PERMANENT CONNECTION TO THE UNIT. THE POWER MUST BE TURNED OFF AND DISCONNECTED WHENEVER PERFORMING MAINTENANCE OR REPAIR FUNCTIONS.

PARTS REMOVAL AND REPLACEMENT PROCEDURES

THERMOSTAT REPLACEMENT

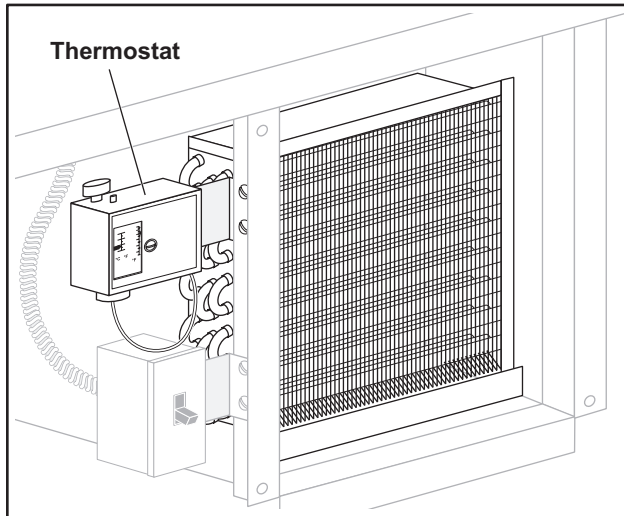

Figure 1. Thermostat Location

The Thermostat is located to the left of the Condenser as shown in Figure 1.

1. Disconnect unit from its power source.
2. Remove the Vent Cover to gain access to the Thermostat Mounting Bracket.
3. Tag and disconnect Thermostat wiring.
4. Remove Thermostat mounting screws.
5. Remove Thermostat Probe from Evaporator coil. Be very careful not to damage the evaporator coil.
6. Install the replacement Thermostat.

NOTE: Do not kink Thermostat Probe.

7. Install Thermostat Probe in Evaporator Coil.
8. Refer to tags to connect Thermostat wiring.
9. Install Vent Cover.
10. Connect unit to power source and test operation.

POWER ON/OFF SWITCH

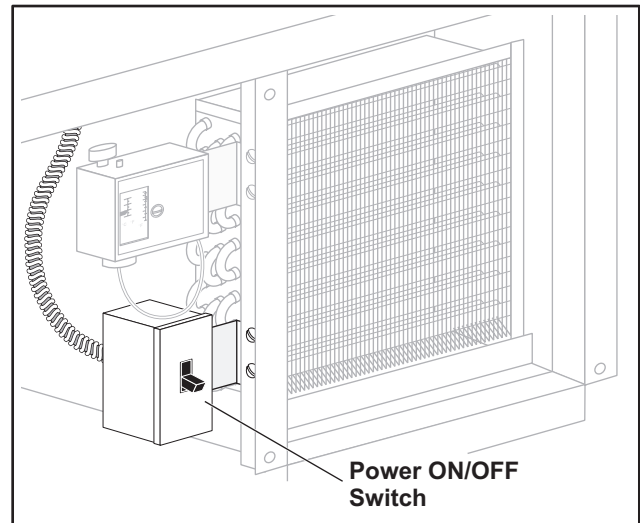

Figure 2. Power ON/OFF Switch Location

The Power ON/OFF Switch is part of the conditioner assembly. It is mounted below the thermostat on the left side of the condenser. The conditioner assembly is available as 115VAC and 220VAC models. Ensure that a properly rated switch is available for the unit being worked on.

1. Remove the unit from its power source.
2. Remove the screws that hold the switch plate on.
3. Remove the screws that hold the switch in place on the electrical box.
4. Pull the switch out of the electrical box.
5. Tag and disconnect the wires to the switch.
6. Refer to the tags to reconnect the wires to the replacement switch.
7. Push the switch into the electrical box.

CAUTION: Make sure the wires are dressed properly as the switch is inserted back into the box.



8. Using the screws provided with the new switch, reattach the switch to the electrical box.

9. Reattach the switch plate.
10. Reconnect the unit to its power source and ensure that the switch is working properly.

EVAPORATOR

The evaporator coils are held in place on the bottom of the cold pan with aluminum tape and imbedded in insulating foam. They cannot be replaced.

REFRIGERATION SYSTEM REPLACEMENT

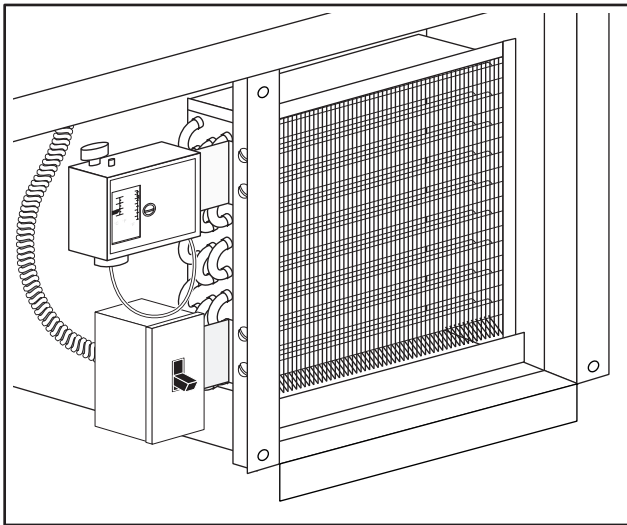

Figure 3. Refrigeration Assembly Location

The Refrigeration Assembly is located in the front of the unit.

1. Disconnect the unit from its power source.
2. Remove the vent cover.
3. Using a Refrigeration-Charging Unit, evacuate refrigerant from the system according to Duke Manufacturing Service Bulletin Number 26.
4. Tag and disconnect the evaporator tubing from Refrigeration Assembly.
5. Remove the Refrigeration Assembly mounting hardware.
6. Tag and disconnect wiring at the junction box.
7. Pull the Refrigeration Assembly through the vent opening.
8. Thoroughly clean the Refrigeration Assembly compartment.

NOTE: Before installing the replacement Refrigeration Assembly, pressure check the evaporator coils for leaks.

9. Place the replacement Refrigeration Assembly onto the slide bars.
10. Slide the Refrigeration Assembly in to the original position.
11. Install the Refrigeration Assembly mounting hardware.
12. Refer to the tags to reattach the evaporator tubing to Refrigeration Assembly.
13. Refer to the tags to reconnect the wiring at the junction box.
14. Connect the unit to its power source and test its operation.
15. Charge the system according to Duke Manufacturing Service Bulletin Number 26.
16. Install the vent cover.

DRAIN REPLACEMENT

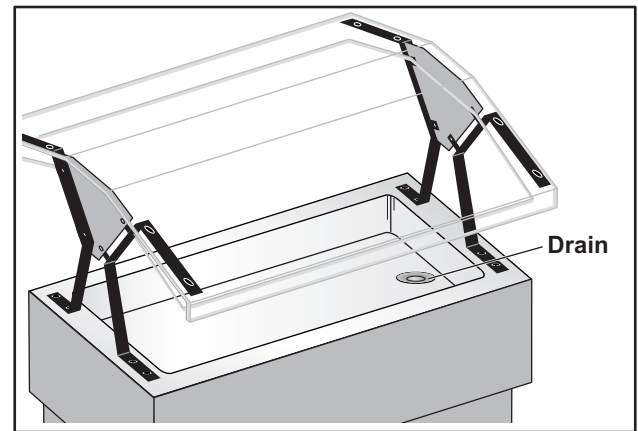

Figure 4. Drain Location

The purpose of the drain is to drain evaporator condensate and ice melt only. Do not pour food product down the drain.

1. Remove the unit from its power source.
2. Disconnect PVC tubing from the PVC barb.
3. Remove the PVC barb and reducer from the drain.

NOTE: On AHC Aerohot Salad Bar models the Globe valve must also be removed.

4. Remove the large nut and gasket that secure the drain to the pan.
5. Push the drain from the bottom up.
6. Clean all remaining drain sealer and gasket material from the top and bottom of the pan.
7. Place a bead of drain sealer around the bottom edge of the new drain.
8. Place the drain into the drain hole in the pan.

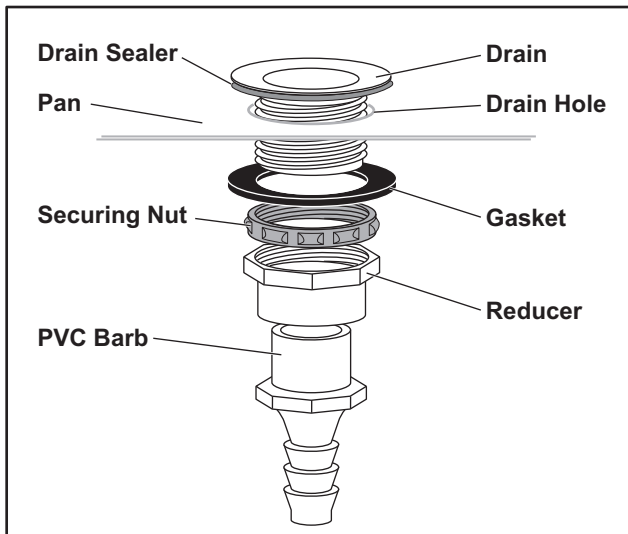



Figure 5. New Drain Assembly

9. Place the gasket (if provided) over the drain down tube.
10. Replace the securing nut.
 -  **CAUTION: Do not overtighten the drain.**
11. Replace the reducer, Globe valve (AHC models only) and PVC barb.
12. Inspect the PVC tubing for damage and replace as needed.
13. Remove excess drain sealer from around the drain.
14. Ensure that there are no leaks.
15. Reconnect the unit to its power source.

PLEXIGLAS CANOPY REPLACEMENT

Economate and Aerohot Salad Bars

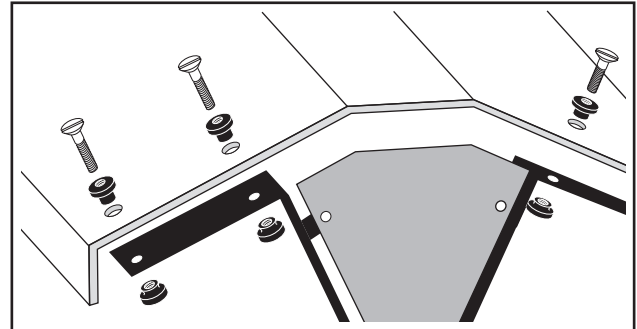

Figure 6. Plexiglas Canopy

The Plexiglas Canopy is mounted to the canopy brackets using rubber grommets.

1. Disconnect unit from power source.
2. Remove the screws that hold the canopy on as depicted in Figure 6.

NOTE: If canopy bracket replacement is required, they can be removed once the Plexiglas Canopy is removed.

3. Remove the rubber grommets from the old canopy.
4. Remove the protective plastic covering from the new canopy.
5. Install rubber grommets in the new canopy.
6. Install the new canopy.

NOTE: Install new canopy brackets first if replacing them.

CAUTION: Do not overtighten the screws. Over tightened screws will crack the Plexiglas.



7. Connect the unit to its power source.

CASTER REPLACEMENT

Economate

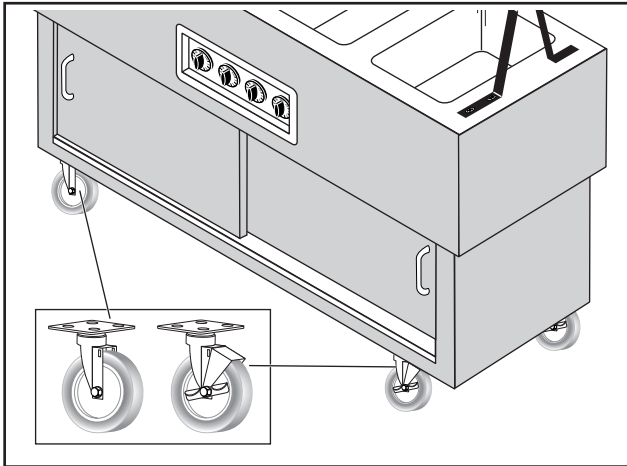

Figure 7. Economate Casters

Economate units are supplied with NSF listed 5" casters. Two casters are provided with locks.

1. Disconnect the unit from its power source.
2. Remove the unit from its base.
3. Turn the base upside down.
4. Remove the four bolts securing the caster to the base.
5. Remove the caster.
6. Replace the caster with a new one.

NOTE: Casters with brakes must be replaced with brake units.

7. Tighten all four mounting bolts.
8. Turn the base unit right side up and reinstall the warmer assembly.
9. Reconnect the unit to its power source.

Heritage, Thurmaduke & AHC Duke Salad Bar Models

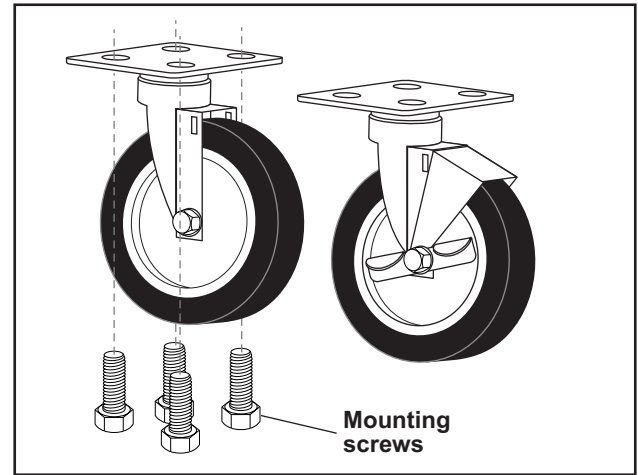

Figure 8. Thurmaduke Casters

Thurmaduke Serving Systems, AeroServ Serving Systems and Heritage models are supplied with NSF listed 5" black swivel casters. Each unit is supplied with a pair of locking casters.

1. Disconnect the unit from its power source.
2. Make sure the pans have been emptied of all content.
3. Raise and support the side of the unit that requires a new caster.
4. Remove the four mounting bolts.
5. Remove the caster.
6. Replace the caster. Always replace locking casters with locking casters.
7. Reattach and tighten the mounting bolts.
8. Remove the unit from the support.
9. Reconnect the unit to its power source.

RECHARGING REFRIGERATION SYSTEM

To analyze the performance of a refrigeration system, temperature readings are recorded and converted to pressure readings using a standard pressure/temperature chart.

Strictly adhere to the following approved procedure, when it is necessary to service a factory sealed refrigeration system.

TOOLS

- Standard hand and refrigeration tools
- Refrigerant Type: R-134A, 4.5 ounces

CHARGING PROCEDURE

NOTE: Prior to refrigeration system service, special care must be taken during the evacuation process to remove air, moisture and other non-condensable material from the system. Duke Manufacturing recommends the following triple evacuation method. Failure to follow this procedure may result in poor refrigeration system performance.



WARNING

NEVER USE OXYGEN OR ACETYLENE IN PLACE OF DRY NITROGEN OR REFRIGERANT FOR LEAK TESTING. A VIOLENT EXPLOSION MAY RESULT, CAUSING PROPERTY DAMAGE, PERSONAL INJURY OR DEATH. WHEN USING NITROGEN TO PRESSURE TEST, ALWAYS USE A PRESSURE REGULATOR. FAILURE TO DO SO WILL RESULT IN EXTREMELY HIGH PRESSURE OF THE COMPRESSOR OR OTHER SYSTEM COMPONENTS AND RESULT IN PROPERTY DAMAGE, PERSONAL INJURY AND DEATH.

1. Evacuate system to 1500 microns

2. Break the vacuum to 2 psig with dry nitrogen. If dry nitrogen is unavailable, use same type of refrigerant as used in system.
3. Evacuate system to 1500 microns.
4. Break the vacuum to 2 psig with dry nitrogen. If dry nitrogen is unavailable, use same type of refrigerant as used in system.
5. Evacuate system to 500 microns.

The system is now ready to receive refrigerant charge according to information on data plate.

NOTE: Prior to repair; ensure that there is enough process hose (approximately 12") present to complete the repair using the above procedure. If not, install a new process hose before repair sequence.

1. Install a temporary access valve on the high and low sides of the process hoses as close to factory crimps as possible.
2. Use temporary valves to perform repair. Duke Manufacturing will not reimburse the cost of permanently installed valves.
3. After completing repair, evacuate system using the triple evacuation method described in Duke Manufacturing Service Bulletin Number 26.
4. After completing proper evacuation method, recharge the system using the proper refrigerant according to information on the data plate.
5. Crimp process hose just below the temporary valve and again 2" below the first crimp.
6. With the crimp tool in place, remove the temporary valve.
7. Braze shut the end of process hose.
8. Allow brazed end to cool for about 5 minutes.
9. Remove the crimp tool.
10. Check the brazed end for leaks.

TROUBLESHOOTING PROCEDURE

SYMPTON	POSSIBLE CAUSE	REMEDY
Cabinet too warm	Unit not plugged in. Thermostat set too warm. Thermostat switch stuck open in coldest position. Evaporator fan not running. Condenser fan motor not running. Dirty condenser coil or filter Refrigerant leak	Plug unit in. Set thermostat to a higher number for a colder temperature. Replace thermostat. Check and repair or replace motor. Check and repair or replace motor. Clean coil or filter. Find leak, repair and recharge.
Cabinet too cold	Thermostat set too cold. Thermostat switch is stuck in the closed position	Set thermostat to a lower number for a warmer temperature. Replace thermostat. Clear drain hose.
Water in bottom of unit	Drain hose plugged Drain hose loose or disconnected from drain pan	Tighten or connect drain hose.



WARNING

THE POWER MUST BE TURNED OFF AND DISCONNECTED AT ALL TIMES DURING MAINTENANCE OR REPAIR FUNCTIONS.

MAINTENANCE

STAINLESS STEEL CARE AND CLEANING

Stainless steel contains 70-80% iron, which will rust. It also contains 12-30% chromium, which forms an invisible passive film over the steel surface and acts as a shield against corrosion. As long as the protective film remains intact, the metal will not corrode. However, if the film is broken or contaminated, outside elements can begin to breakdown the steel and begin to form rust or discoloration. To prevent rust and discoloration on stainless steel, several important steps need to be taken.

CAUTION: Never use steel wool pads, wire brushes or scrapers.



Avoid cleaning solutions that contain alkaline or chloride.

Use non-alkaline based or non-chloride cleaning solutions. Anything containing chloride will damage the protective film on stainless steel. Chlorides are found in household and industrial cleaners and also in hard water and salts. If a chloride or alkaline cleaner has been used, rinse repeatedly and dry thoroughly.

Always use only soft cloths or plastic scouring pads. Use warm soapy water for routine cleaning. A non-abrasive cleanser may be used on stubborn stains. For heavy grease, use a degreaser. For best results, rub with the grain of the steel.

Pitting and cracking are early signs of stainless steel breakdown. Special stainless steel cleaners can restore and preserve the protective film. If signs of breakdown appear, thoroughly clean and dry all surfaces. Begin regular application of a high quality stainless steel cleaner according to the manufacturer's instructions.

Again, always rub with the grain of the steel for best results.

CAUTION: Never use an acid-based cleanser! Be sure to clean all food products from any stainless surface. Many food products contain acid, which can deteriorate the finish. Common acidic foods include tomatoes, peppers and other vegetables.



CARE AND CLEANING: PAINTED OR POWDER COATED UNITS

Paint and Powder Coat are applied finishes. They are applied to a paint-ready steel surface. Like stainless steel, units with these coatings should be cleaned with mild soap and a soft cloth. Stubborn stains can be removed with a plastic scrubbing pad. Never use abrasive materials to clean painted or powder coated surfaces. After cleaning with mild soap and a soft cloth, painted and powder coated surfaces must be rinsed with warm water and a soft cloth to remove soap residue. Always wipe painted or powder coated surfaces dry with a soft dry cloth after cleaning.

CLEANING THE CONDENSER COIL

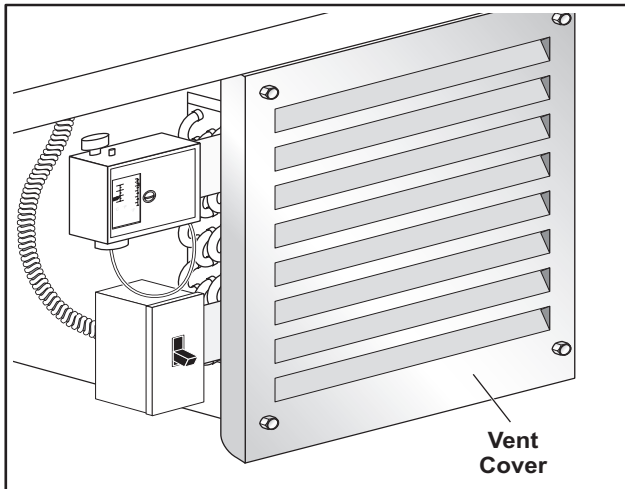

Figure 9. Condenser Coil Location

Failure to maintain a clean condenser coil can cause high temperatures and excessive run times. Continuous operation with dirty or clogged condenser coils can result in compressor failure.

Neglecting the condenser coil cleaning procedures will void the compressor warranty.

CAUTION: Never use a high-pressure water wash to clean the condenser. High-pressure wash can damage electrical components located at or near the condenser coil.

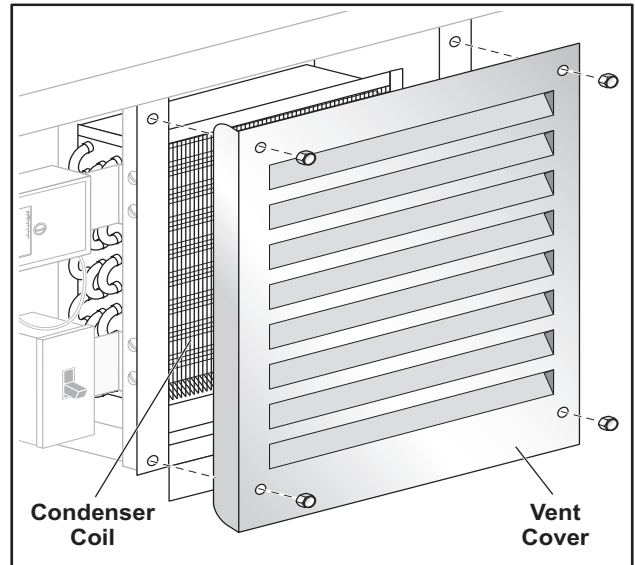

Figure 10. Condenser Coil – VentCover Removed

The condenser coil is located and accessed from the front of the unit (see Figure 2). A vent cover protects the condenser from damage (see Figure 1). The condenser coil requires regular cleaning and should be done every 60 days. However, if large amounts of dust and grease accumulate, clean the condenser coil every 30 days.

For light dust, use a soft, non-wire brush. For heavier dust, use a vacuum cleaner or blow with compressed air.

For heavy grease, use a degreasing agent made specifically for condenser coils on refrigeration units. Spray the degreasing agent on the coil and then blow with compressed air. Never wash the condenser with high-pressure water. High-pressure water can damage or bend the cooling fins on the condenser, reducing its efficiency. Water can also damage the electrical components located near the condenser coil.



Duke Manufacturing Company

2305 N. Broadway • St. Louis, MO 63102

800.735.3853 • 314.231.1130

Fax: 314-231-5074

www.dukemfg.com