



Your Solutions Partner

**FLEXIBLE
BATCH BROILER –
ELECTRIC
DOMESTIC AND
INTERNATIONAL**

MODELS

**FBB-EO-208
FBB-EC-208
FBB-EO-230
FBB-EC-230
FBB-EO-240
FBB-EC-240**

Illustrated Parts List

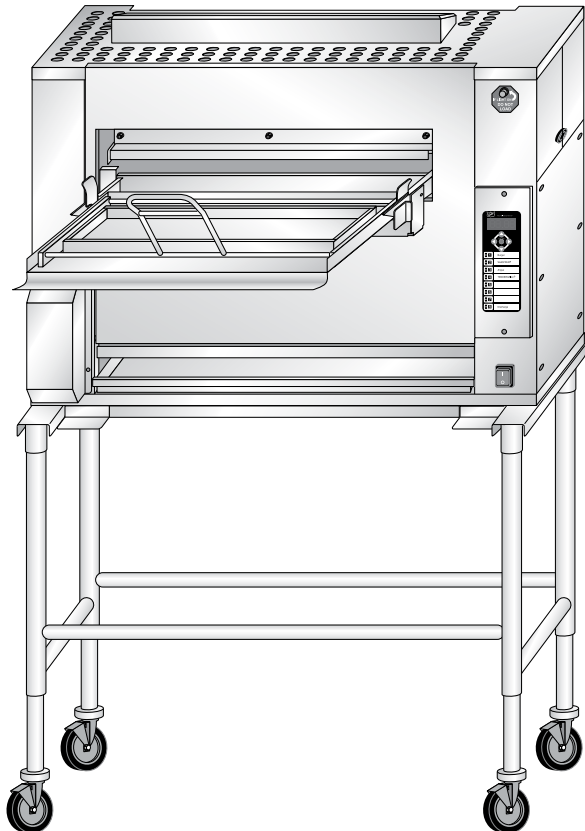

*This manual is Copyright © 2018 Duke Manufacturing Co. All rights reserved.
Reproduction without written permission is prohibited. Duke is a registered
trademark of the Duke Manufacturing Co..*

Duke Manufacturing Co.

**2305 N. Broadway
St. Louis, MO 63102
Phone: 314-231-1130
Toll Free: 1-800-735-3853
Fax: 314-231-5074
www.dukemfg.com**

How to Determine Manufacture Date from Duke Equipment Serial Numbers

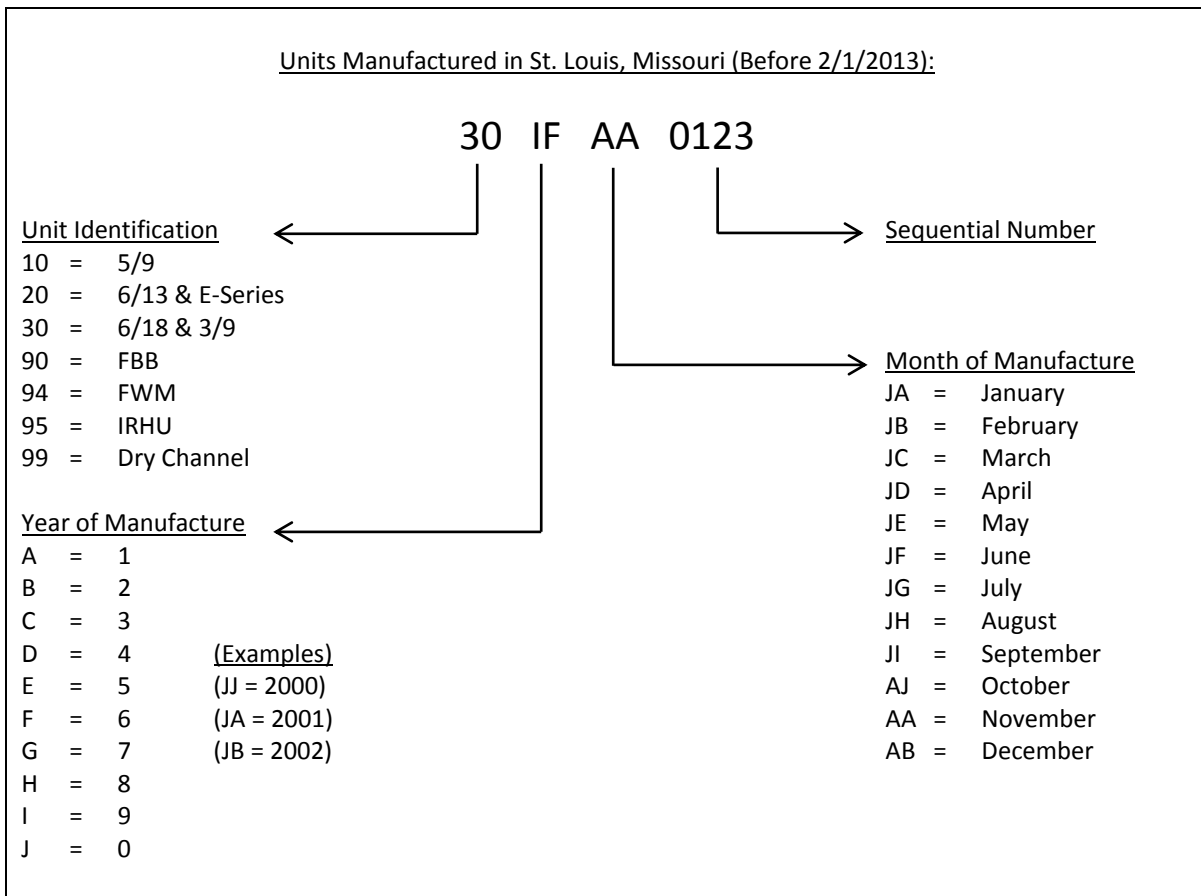
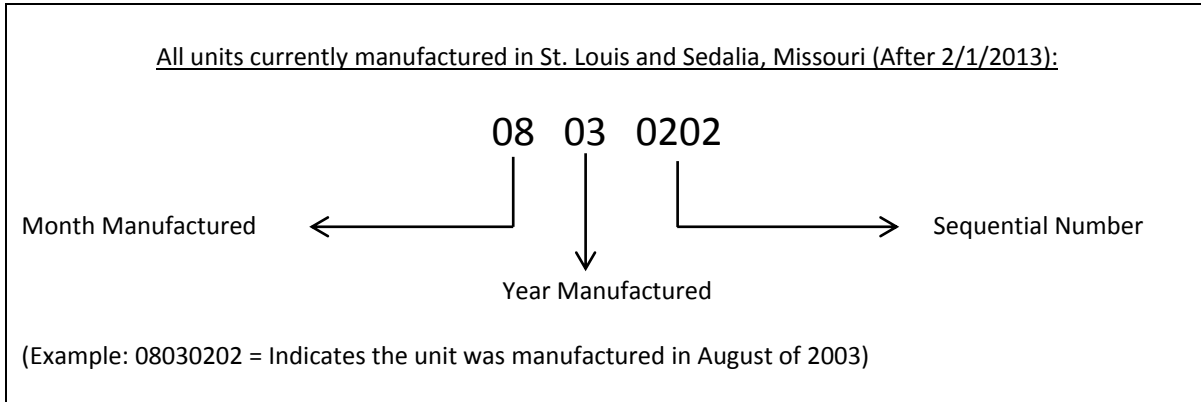

TABLE OF CONTENTS

PANELS, COVERS & PANS	4
Table: PL-1 Panels, Covers & Pans	4
Figure: PL-1 Panels, Covers & Pans.....	5
REAR & DISCHARGE COMPONENTS.....	6
Table: PL-2 Rear & Discharge Components.....	6
Figure: PL-2 Rear & Discharge Components	7
TOP, FRONT & ELECTRICAL COMPONENTS	8
Table: PL-3 Top, Front & Electrical Components	8
Figure: PL-3 Top, Front & Electrical Components	9
STAND COMPONENTS.....	10
Table: PL-3 Stand Components.....	10
Figure: PL-3 Stand Components	11
WIRE SCHEMATIC DOMESTIC	12
WIRE SCHEMATIC CE	13

PANELS, COVERS & PANS

ITEM	DESCRIPTION	P/N
1	PRODUCT HOLDING PAN	156634
2	REAR PANEL	177052
3	INTERLOCK, SAFETY, MAGNET, BACK PANEL MOUNTED	177567
4	BODY TOP	177303
5	CATALYST, GUARD	175482
6	IMPEDANCE PAN (IF NO OPTIONAL CATALYST)	175226
7	CATALYST (OPTIONAL)	175480
8	INTERLOCK, SAFETY, MAGNET, CONTROL COMPARTMENT MOUNTED	177568
9	PANEL, ELEMENT CONNECTION ACCESS	177054
10	PANEL, FUSE ACCESS PANEL	177053
11	PANEL, ACCESS ELECTRICAL	177101
12	FRONT PANEL	175300K
13	LOADER RAMP	175741K
14	WELDMENT, HINGED DOOR	175429K
15	LOADER MOUNTING BRACKET	175878K
16	LOADER	175444K
Not Shown	KIT, HOT DOG LOADER	176818
17	LOADER TRAY	175430K
18	MAIN GREASE PAN	175329
19	“V” GREASE PAN	177011
20	PANEL, FRONT COOK CHAMBER	177154
21	KIT, FLAME ARRESTOR	600222
22	REFLECTOR, HEATING ELEMENT, LOWER	177012
23	HEATING ELEMENT KIT, 3300 W, #1, TOP, LEFT, 208 VAC	600204
	HEATING ELEMENT KIT, 3300 W, #1, TOP, LEFT 230 VAC	600205K
	HEATING ELEMENT KIT, 3300 W, #1, TOP, LEFT 240 VAC	600206
24	HEATING ELEMENT KIT, 3300 W, #2, TOP, CENTER, 208 VAC	600207
	HEATING ELEMENT KIT, 3300 W, #2, TOP, CENTER, 230 VAC	600208K
	HEATING ELEMENT KIT, 3300 W, #2, TOP, CENTER, 240 VAC	600209
25	HEATING ELEMENT KIT, 3300 W, #3, TOP, RIGHT 208 VAC	600210
	HEATING ELEMENT KIT, 3300 W, #3, TOP, RIGHT 230 VAC	600211K
	HEATING ELEMENT KIT, 3300 W, #3, TOP, RIGHT 240 VAC	600212
26	HEATING ELEMENT KIT, 3800/2200 W, #4, BOTTOM, LEFT, 208 VAC	600213K
	HEATING ELEMENT KIT, 3800/2200 W, #4, BOTTOM, LEFT 230 VAC	600214K
	HEATING ELEMENT KIT, 3800/2200 W, #4, BOTTOM, LEFT 240 VAC	600215
27	HEATING ELEMENT KIT, 3800 W, #5, BOTTOM, CENTER, 208 VAC	600216K
	HEATING ELEMENT KIT, 3800 W, #5, BOTTOM, CENTER, 230 VAC	600217K
	HEATING ELEMENT KIT, 3800 W, #5, BOTTOM, CENTER, 240 VAC	600218
28	HEATING ELEMENT KIT, 3800 W, #6, BOTTOM, RIGHT 208 VAC	600219
	HEATING ELEMENT KIT, 3800 W, #6, BOTTOM, RIGHT 230 VAC	600220K
	HEATING ELEMENT KIT, 3800 W, #6, BOTTOM, RIGHT 240 VAC	600221
29	MOTOR COVER, CONVEYOR DRIVE MOTOR	175177
30	DISCHARGE SHIELD	177155
31	PIVOT ASH SCRAPER	175150K
32	PANEL, ACCESS DISCHARGE	175866
Not Shown	KIT, BRACKET, DISCHARGE CHUTE	600330
33	DISCHARGE CHUTE	175340
34	PRODUCT PAN SHELF	175353
35	DISCHARGE HOOD	175778K
36	DISCHARGE PAN	175358K
37	GREASE PAN, SIDE	175357K
Not Shown	LATCH, PIN	177527
Not Shown	LATCH, TOGGLE	177525

Table: PL-1 Panels, Covers & Pans

PANELS, COVERS & PANS

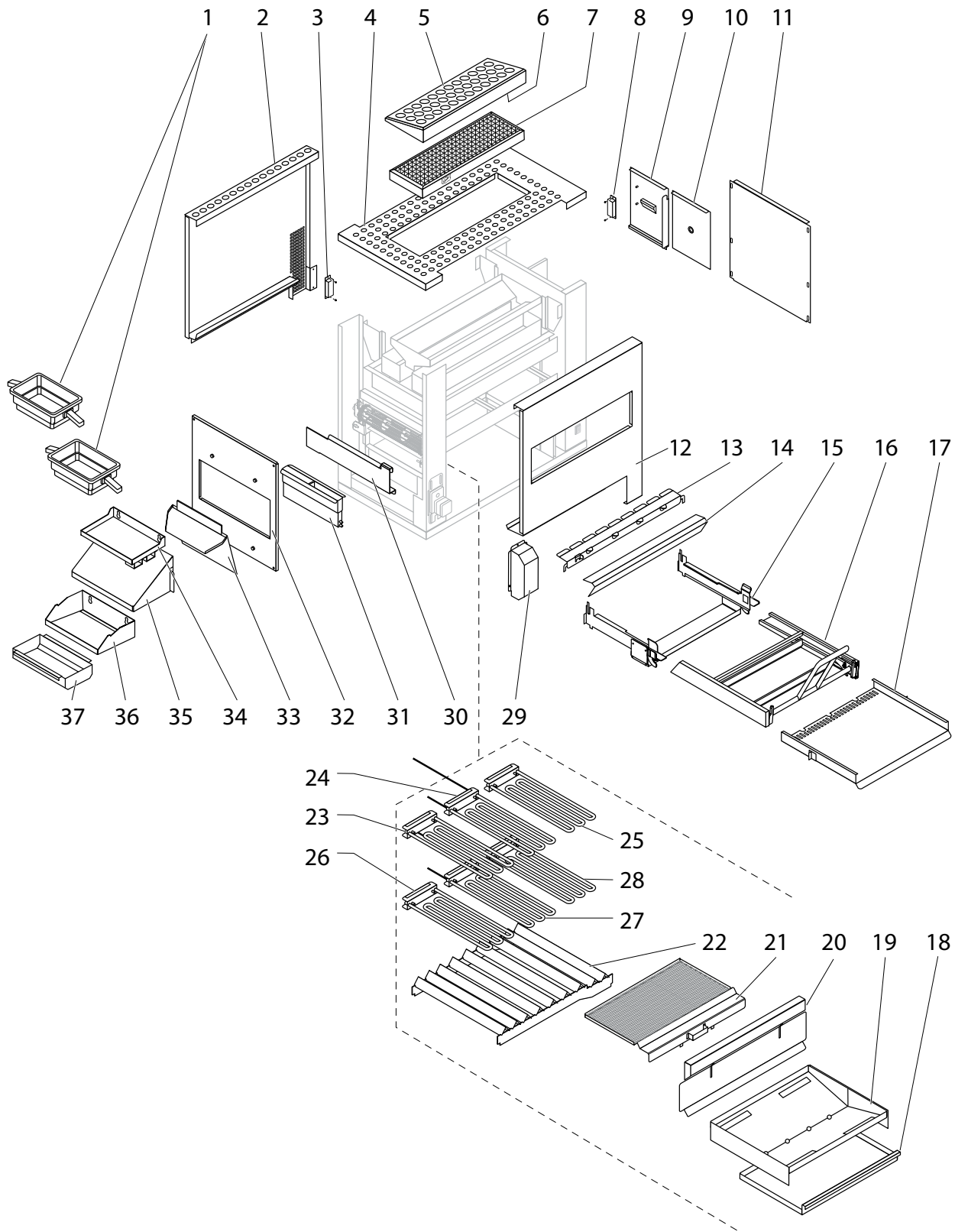

Figure: PL-1 Panels, Covers & Pans

REAR & DISCHARGE COMPONENTS

ITEM	DESCRIPTION	P/N
38	BACK ELEMENT COVER	177097
39	PLUG, PIN & SLEEVE	177569
40	POWER CORD	177094
41	STRAIN RELIEF	177575
42	KIT, TEMPERATURE PROBE	175977K
43	BUSHING BLOCK, CONVEYOR	175525
44	MOUNTING BRACKET, CONVEYOR BUSHING BLOCK, LEFT SIDE	175022
45	SHAFT, DISCHARGE SIDE	175037K
46	CHAIN, DRIVE	175551
47	CHAIN, COOK	175674

Table: PL-2 Rear & Discharge Components

REAR & DISCHARGE COMPONENTS

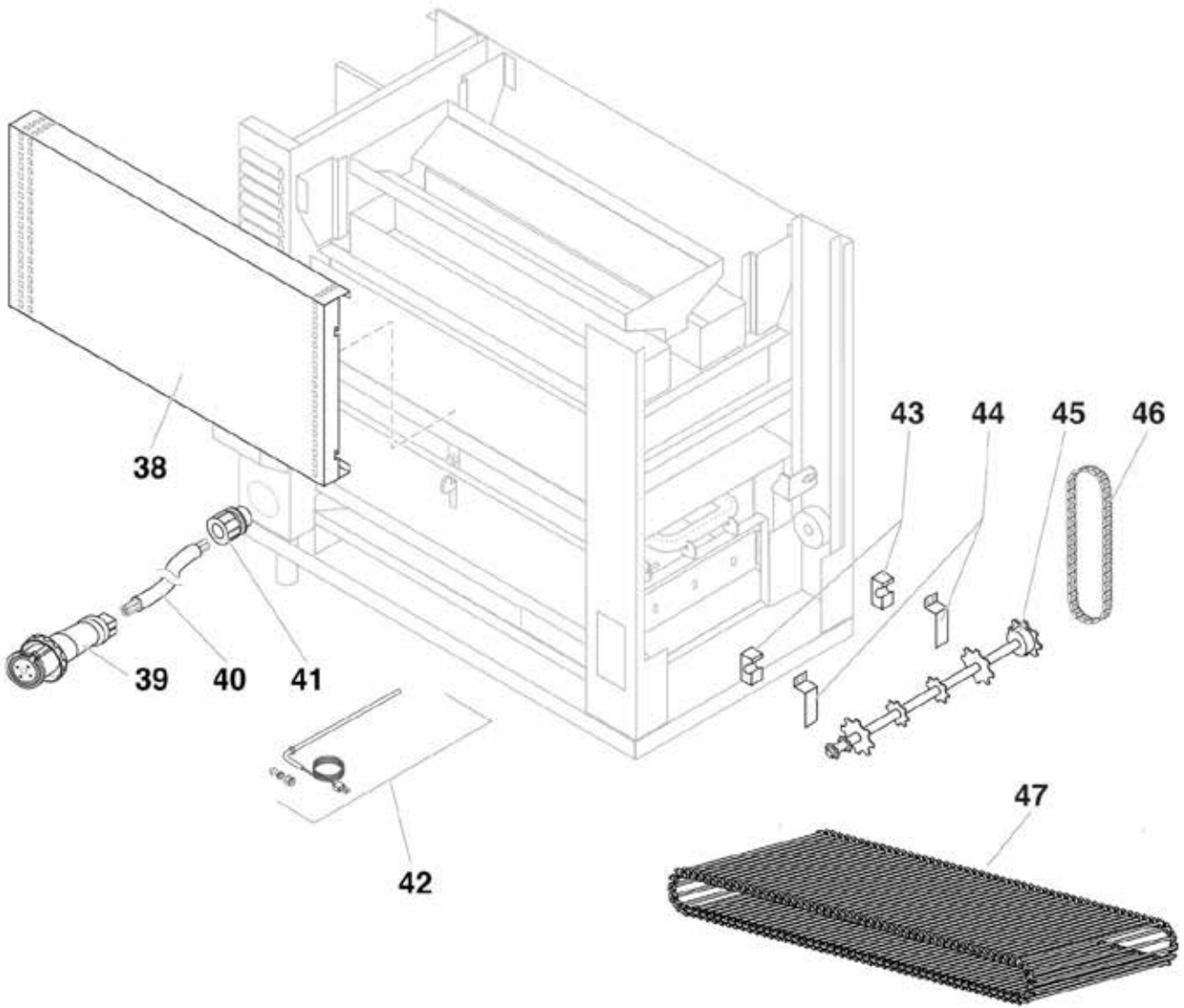

Figure: PL-2 Rear & Discharge Components

TOP, FRONT & ELECTRICAL COMPONENTS

ITEM	DESCRIPTION	P/N
48	MOTOR, CONVEYOR	175875K
49	MOUNTING BRACKET, MOTOR	175176
50	SPROCKET, B21X3/8 BORE (MOTOR)	175517
51	ASSEMBLY, FUSEHOLDER PANEL 208/230/240V	177099
52	INTERLOCK SAFETY SWITCH, REAR PANEL	177044
53	CIRCUIT BREAKER, 10 AMP	177562
54	FUSE	177637
55	COOLING FAN	177329
56	FUSE HOLDER	177513
57	INTERLOCK SAFETY SWITCH, ELECTRICAL ACCESS PANEL	177042
58	SENSOR, CURRENT	167614
59	LIGHT, COOK	175550
60	GASKET, CONTROL BEZEL	175510
61	ASSEMBLY, CONTROLLER, DOMESTIC, 208 VAC	177091
	ASSEMBLY, CONTROLLER, CE 230 VAC	177092K
	ASSEMBLY, CONTROLLER, DOMESTIC, 240 VAC	177337
Not Shown	KIT, MYLAR REPLACEMENT	176039
62	BEZEL, CONTROL	175356
63	SWITCH, LIGHTED, DPST	175503
64	SHAFT, RIGHT SIDE	175038
65	BUSHING BLOCK, CONVEYOR	175525
66	CONTROL, DIAGNOSTIC BOARD	177331
67	MECHANICAL RELAY, DPDT, 10A	177571
68	TRANSFORMER, 40VA, 230VAC-24VAC	175765
69	RELAY, SOLID STATE, 10 AMP, CONVEYOR	175870K
70	CAPACITOR, MOTOR-CONVEYOR	175802
71	CONTACTOR	177330
72	TERMINAL BLOCK, SUPPLY 3P 175A (208/240V)	177502
	TERMINAL BLOCK, SUPPLY 4P 80A (230V)	177503
73	RELAY, SOLID STATE, 50 AMP, DC INPUT, HEATING ELEMENT	177096
74	RELAY, SOLID STATE, 50 AMP, AC INPUT, HEATING ELEMENT	177095K
75	THERMOSTAT, HEAT SINK	168324
76	TERMINAL BLOCK, HEAT ELEMENTS DOMESTIC (208/240V)	177504
	TERMINAL BLOCK, HEAT ELEMENTS CE (230V)	177505
HARNESSES		
Not Shown	HARNESS, SSR SUPPLY	177601
Not Shown	HARNESS, TB & CT MAIN POWER	177602
Not Shown	HARNESS, SSR FUSE AND TERMINAL	177724
Not Shown	HARNESS, CURRENT SENSORS	177605
Not Shown	HARNESS, CONTROL AC POWER	177606
Not Shown	HARNESS, LOW VOLTAGE	177607
Not Shown	HARNESS, CONTROL TO DIAGNOSTIC BOARD	177597
Not Shown	HARNESS, FUSES & ELEMENT PLUGS	177599
Not Shown	HARNESS, CONVEYOR MOTOR	175609

Table: PL-3 Top, Front & Electrical Components

TOP, FRONT & ELECTRICAL COMPONENTS

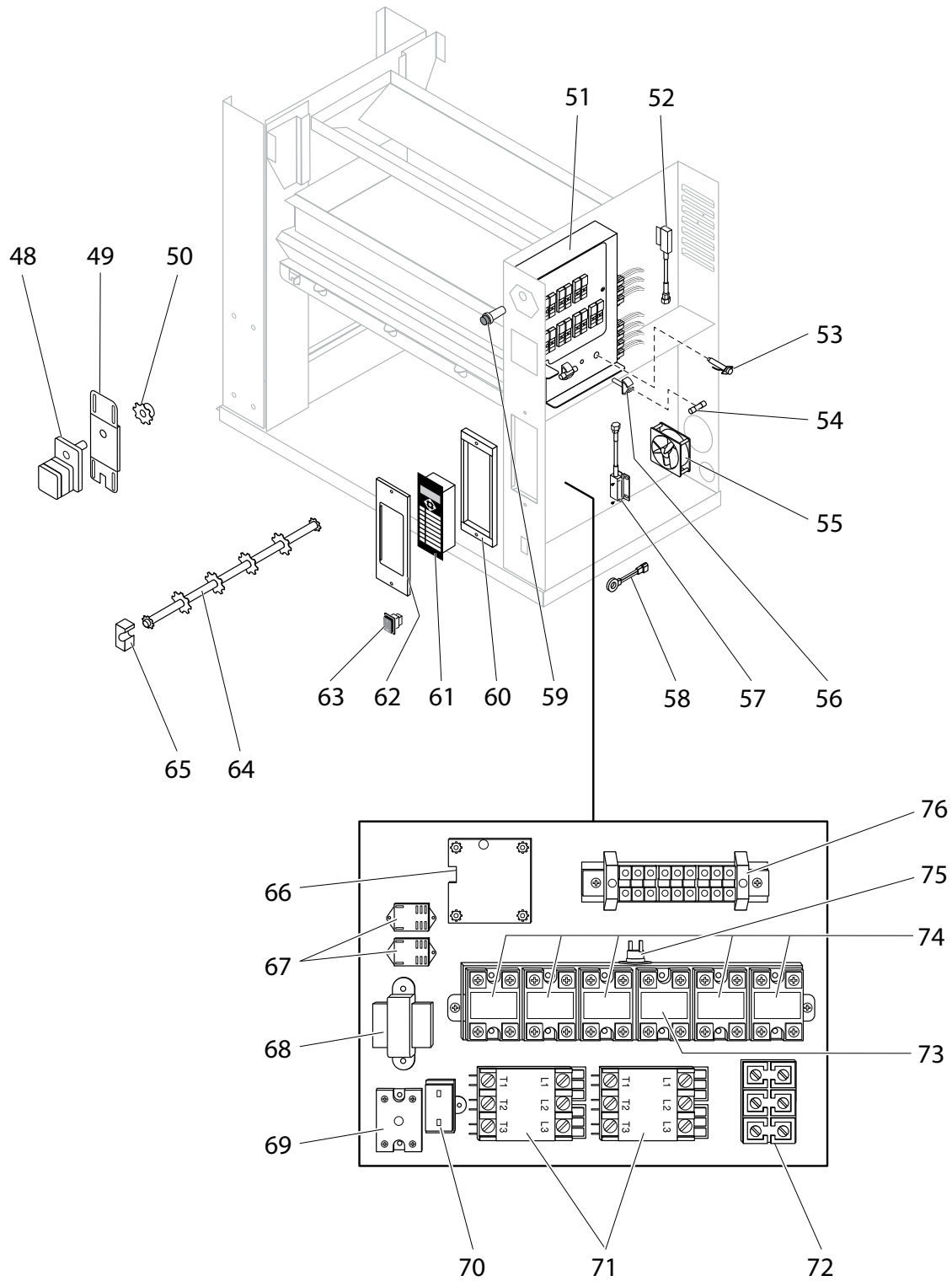

Figure: PL-3 Top, Front & Electrical Components

STAND COMPONENTS

ITEM	DESCRIPTION	P/N
77	WELDMENT, KD WELDED BROILER STAND	175999
78	ASSEMBLY, LEG EXTENSION W/BRAKE	175462PC
79	ASSEMBLY, LEG EXTENSION W/O BRAKE	175463PC
80	WELDMENT, TOP BROILER STAND	175961PC
81	WELDMENT, SANITIZER BRACKET	175748
82	SCREW, 5/16-18 X 3/4 BT SKT S	175468
83	SADDLE, U-BOLT	175459
84	U-BOLT, 1/4-20 X 1-1/4	175565
85	NUT, 1/4-20 ACORN SS	0220750SED
86	PIPING, GAS SUPPLY	175570
87	SCREW, 10-24 X 3/8" PTHMS SS	213028
88	KIT, NYLON RIVET	175722PC
89	WELDMENT, CLEANING TOOL	177301
90	SANITATION PAIL	175842

Table: PL-3 Stand Components

STAND COMPONENTS

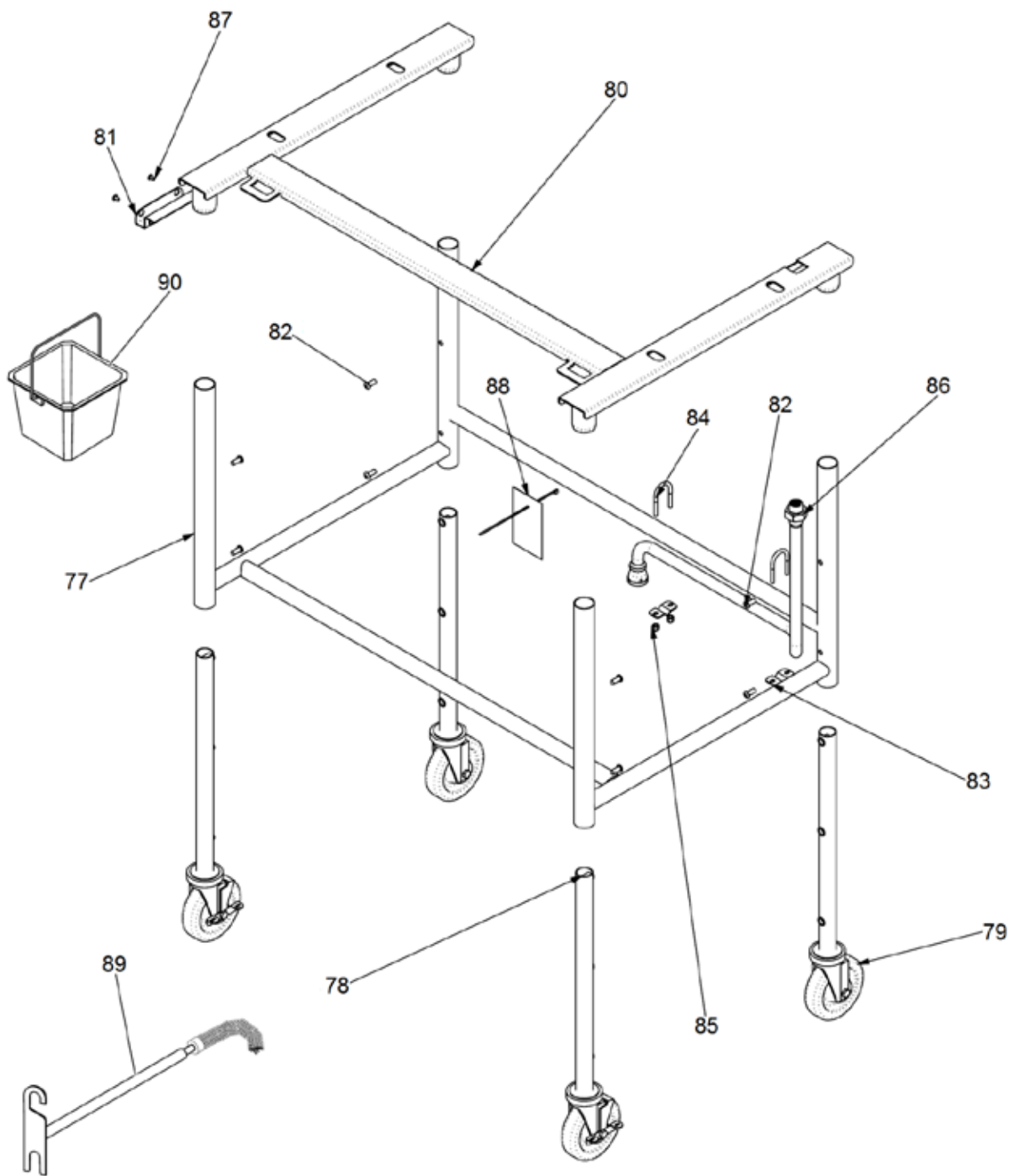
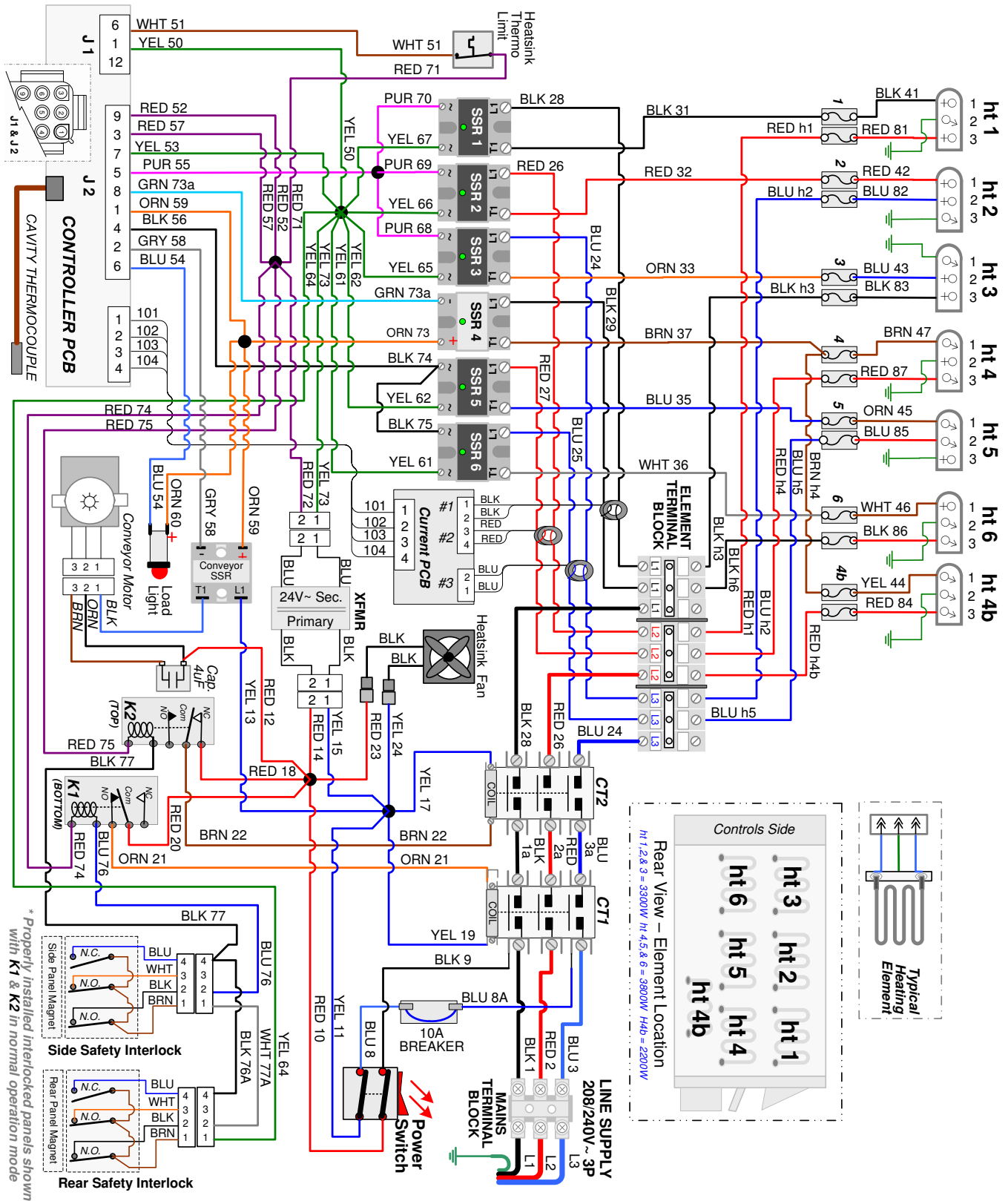

Figure: PL-3 Stand Components

Wire Diagram - Electric FBB, 208/240V~ 3P

* Shown with power ON & in normal operation mode



Wire Diagram - Electric FBB, 400 3N 50Hz

* Shown with power ON & in normal operation mode

177624C
1/29/10

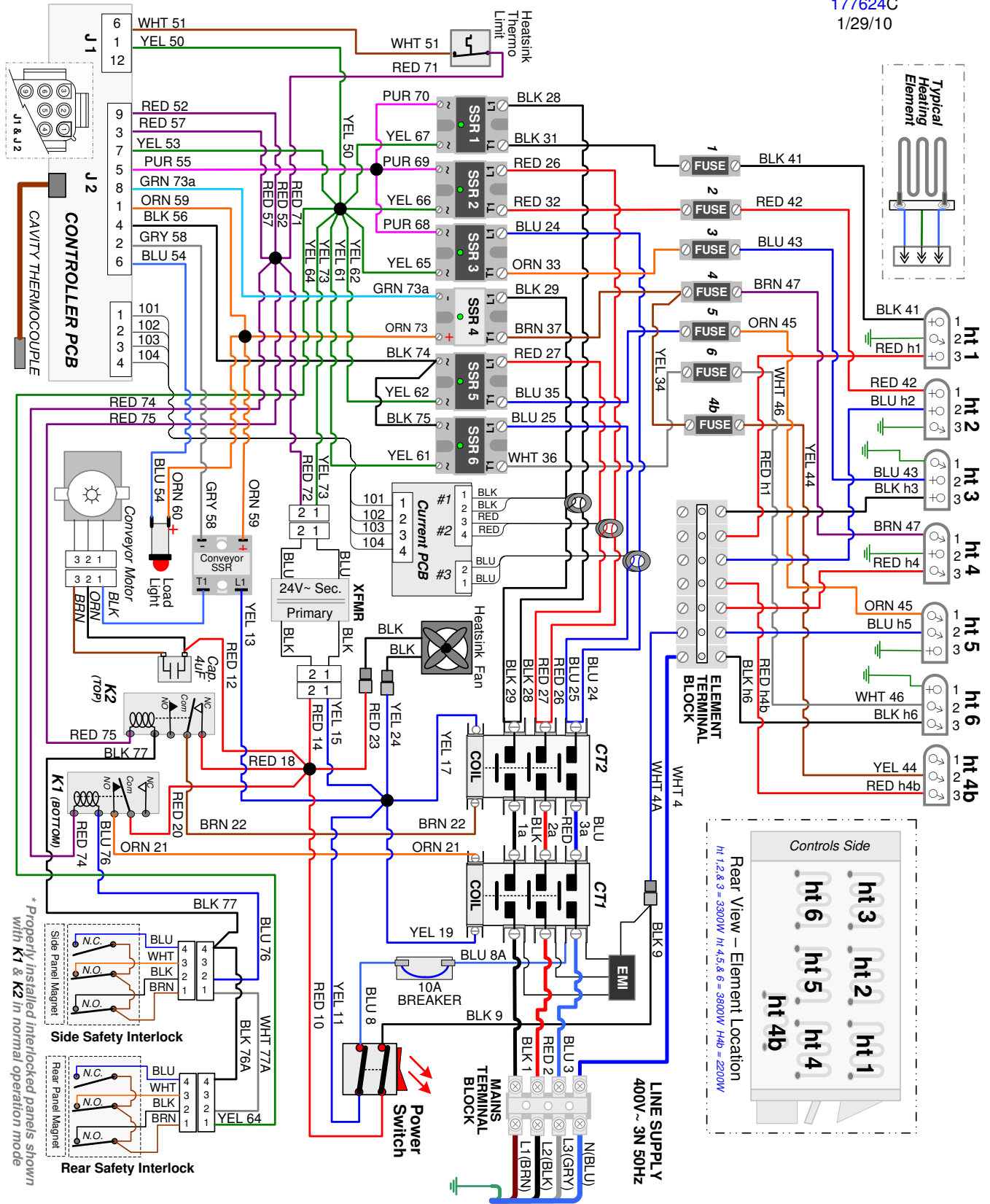



Your Solutions Partner

Duke Manufacturing Co.

2305 N. Broadway • St. Louis, MO 63102

800-735-3853 • 314-231-1130

Fax: 314-231-5074

www.dukemfg.com