

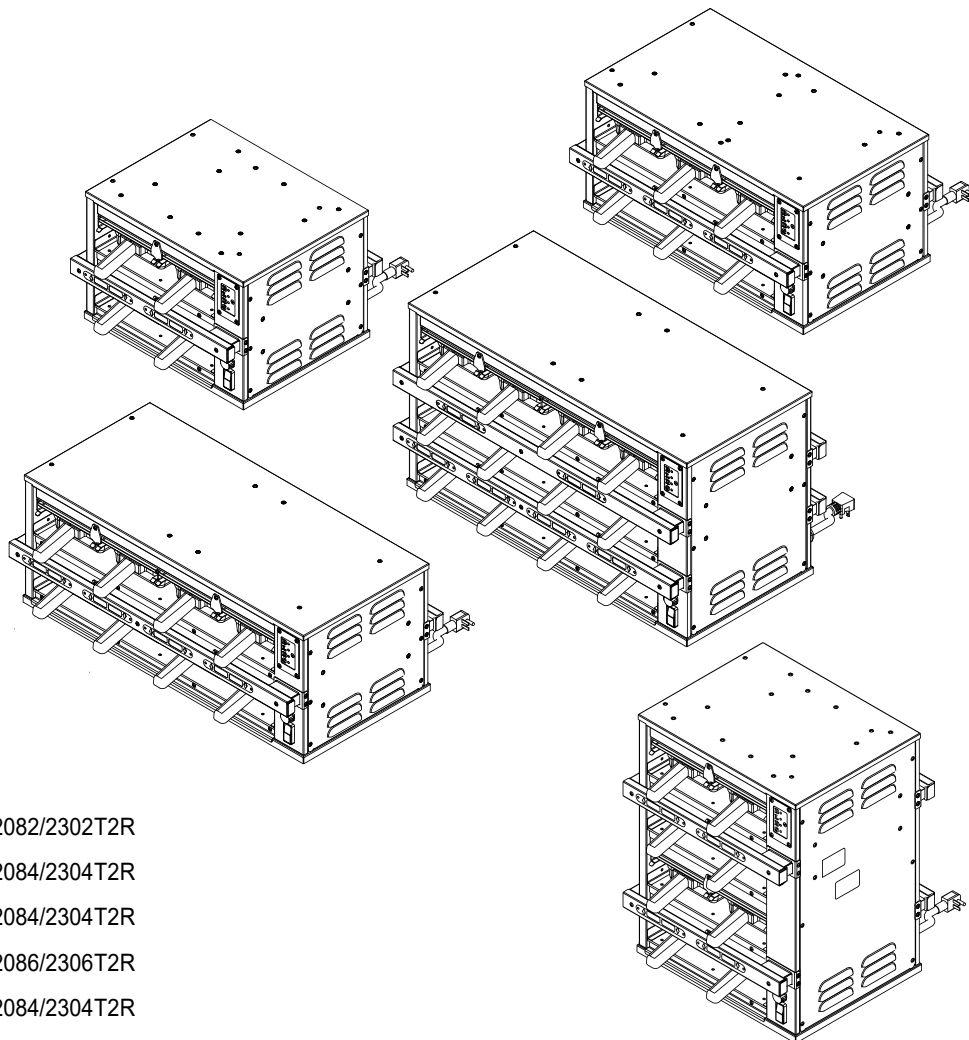

Your Solutions Partner

# Illustrated Parts List

## HS2 DUAL HEATSINK HOLDING UNITS



### MODELS

HS2-22-2082/2302T1R	HS2-22-2082/2302T2R
HS2-23-2084/2304T1R	HS2-23-2084/2304T2R
HS2-24-2084/2304T1R	HS2-24-2084/2304T2R
HS2-34-2086/2306T1R	HS2-34-2086/2306T2R
HS2-42-2084/2304T1R	HS2-42-2084/2304T2R

---

*This manual is Copyright © 2019 Duke Manufacturing Co. All rights reserved.  
Reproduction without written permission is prohibited. Duke is a registered  
trademark of the Duke Manufacturing Co.*

## Duke Manufacturing Co.

2305 N. Broadway • St. Louis, MO 63102  
800.735.3853 • 314.231.1130  
Fax: 314-231-5074  
[www.dukemfg.com](http://www.dukemfg.com)

## TABLE OF CONTENTS

HS2 MODEL NUMBER CONVENTION .....	3
TIMER BAR MODELS (HS2-22-2082/2302 T1R & T2R) .....	4
Figure: PL-2 TIMER BAR MODELS (HS2-22-2082/2302 T1R & T2R) .....	4
Table: PL-2 TIMER BAR MODELS (HS2-22-2082/2302 T1R & T2R) .....	5
TIMER BAR MODELS (HS2-23-2084/2304 T1R & T2R) .....	6
Figure: PL-4 TIMER BAR MODELS (HS2-23-2084/2304 T1R & T2R) .....	6
Table: PL-4 TIMER BAR MODELS (HS2-23-2084/2304 T1R & T2R) .....	7
TIMER BAR MODELS (HS2-24-2084/2304/2404 T1R & T2R) .....	8
Figure: PL-6 TIMER BAR MODELS (HS2-24-2084/2304 T1R & T2R) .....	8
Table: PL-6 TIMER BAR MODELS (HS2-24-2084/2304 T1R & T2R) .....	9
TIMER BAR MODELS (HS2-34-2086/2306/2406 T1R & T2R) .....	10
Figure: PL-8 TIMER BAR MODELS (HS2-34-2086/2306 T1R & T2R) .....	10
Table: PL-8 TIMER BAR MODELS (HS2-34-2086/2306 T1R & T2R) .....	11
TIMER BAR MODELS (HS2-42-2084/2304/2404 T1R & T2R) .....	12
Figure: PL-10 TIMER BAR MODELS (HS2-42-2084/2304 T1R & T2R) .....	12
Table: PL-10 TIMER BAR MODELS (HS2-42-2084/2304 T1R & T2R) .....	13
WIRING DIAGRAMS .....	14
HS2-22, 2-Zone Models .....	14
HS2-23, 2-Zone Models .....	15
HS2-23, 4-Zone Models .....	16
HS2-24, 4-Zone Models .....	17
HS2-34, 6-Zone Models .....	18
HS2-42, 4-Zone Models .....	19
HS2-22, 2-Zone CE Models .....	20
HS2-23, 4-Zone CE Models .....	21
HS2-24, 4-Zone CE Models .....	22
HS2-34, 6-Zone CE Models .....	23
HS2-42, 4-Zone CE Models .....	24

## HS2 MODEL NUMBER CONVENTION

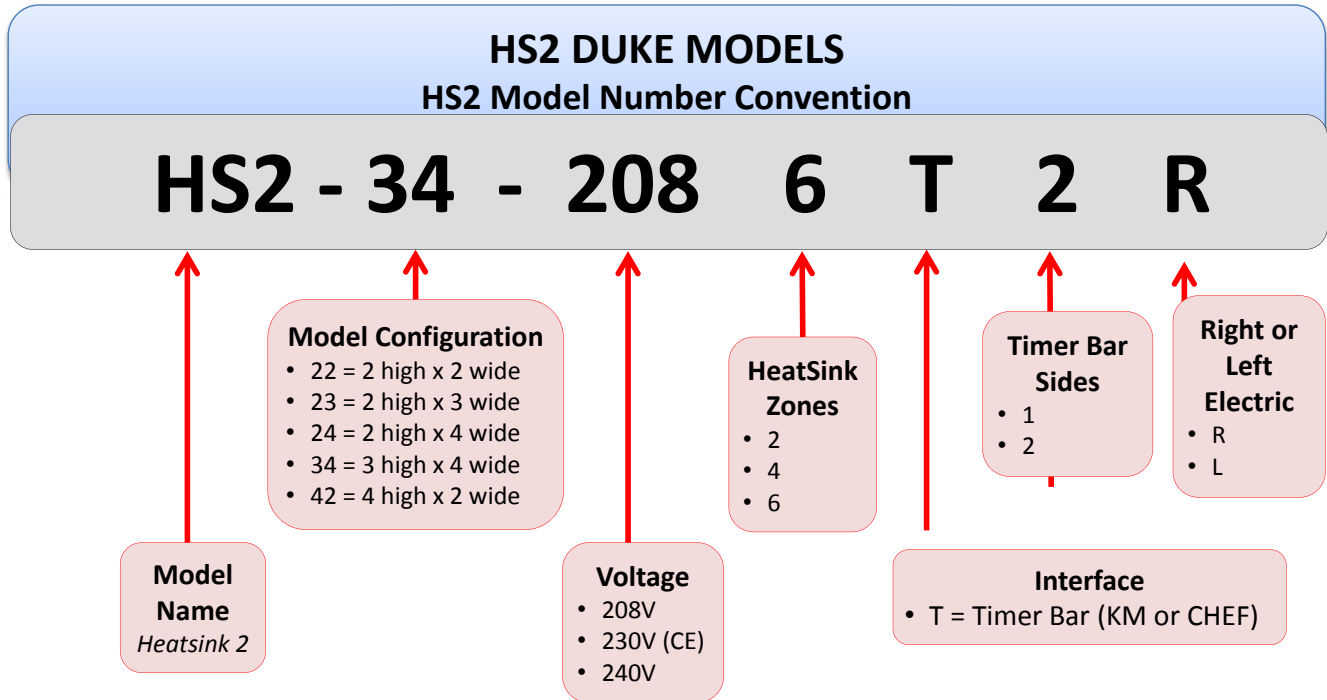

## TIMER BAR MODELS (HS2-22-2082/2302 T1R & T2R)

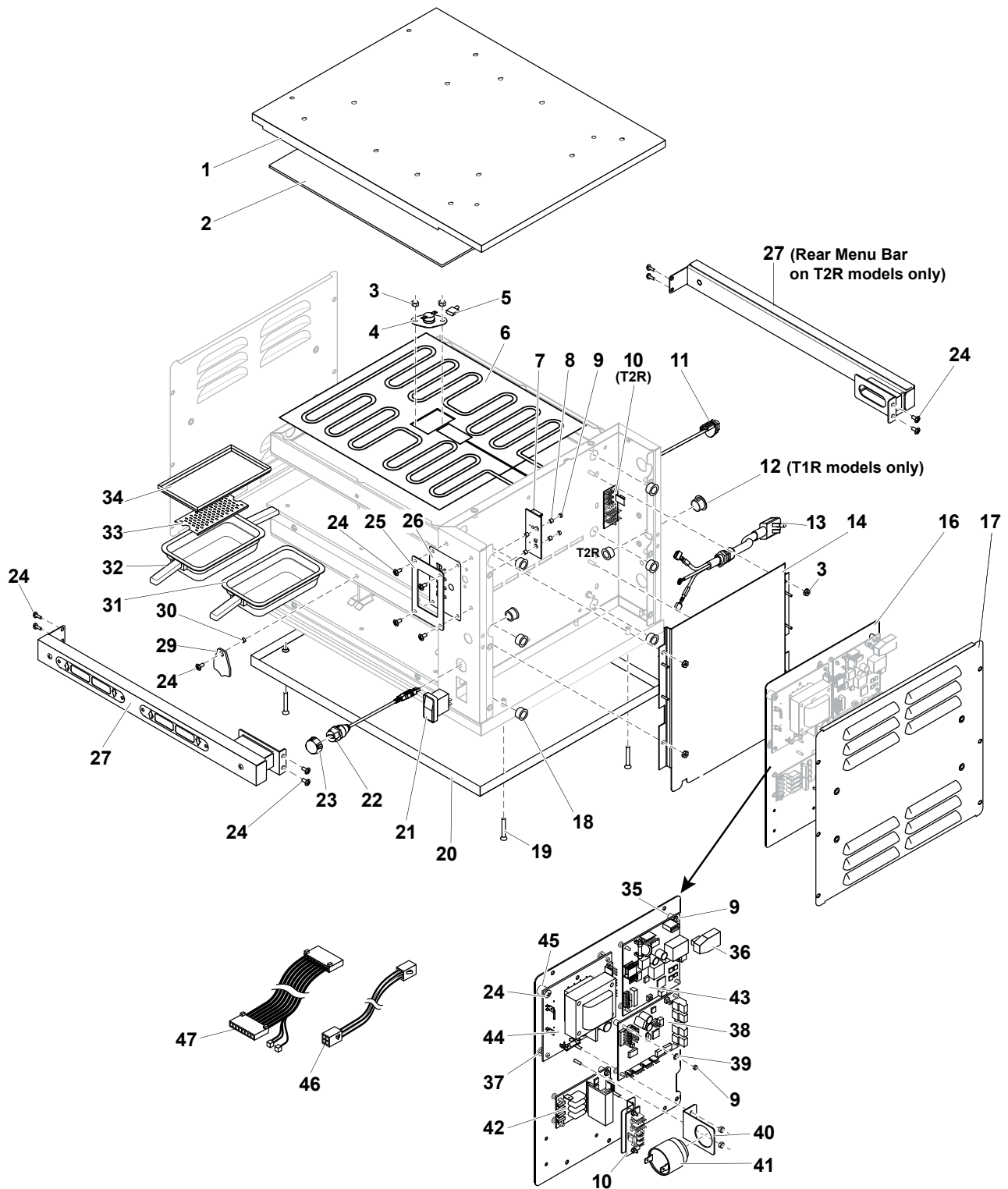

Figure: PL-1 TIMER BAR MODELS (HS2-22-2082/2302 T1R & T2R)

**TIMER BAR MODELS (HS2-22-2082/2302 T1R & T2R)**

ITEM	PN	DESCRIPTION	QTY	
			T1R - Models	T2R - Models
1	1059-0521	HS2, TOP 2W RF		1
2	1059-0528	HS2, INSULATION 1/8" 2W		1
3	155680	NUT, KEPS 8-32 HEX ZP		42
4	158312	THERMOSTAT, HI-LIMIT 300 DEG W/FLANGE		4
5	222603	WIRE, JUMPER HS2 HEAT ELEMENT COM.		4
6	225225	Heater, 2 Wide 208/240V,		4
Not shown	158279	RTD, 1000 OHM-MEDIUM		A/R
7	225184	DUKE DAY PART PCB		1
8	225171	SPACER ROUND 1/4" X 1/8" IS DIA .115		4
9	223470	NUT, 4-40 NYLON LOCKNUT		7
10	225181	ASY, TIMER BAR 5V POWER PCB	1	2
11	118440	RJ45 Ethernet Cable, Panel Mount (Replaced 118003 & 166111)		1
	166111	MODULAR, JACK IP67 (Replaced by 118003 -- 8/1/2017)		1
12	1059-0723	HS2, MENU BAR HOLE PLUG	1	-
13	222170	POWER CORD, 15A 250V, W/TERMINALS, 6' LG (208/240V Units)		1
	160448	POWER CORD, 16A 230V, W/TERMINALS, 8' LG (230V Units)		1
14	1059-0729	HS2, CRTL MTG PLATE 2H PEMS (Replaced 1059-0435)		1
16	1059-0735	HS2, ASY, DMC CRTL MTG PLATE (Replaced 1059-0537)		1
17	1059-0446	ACCESS PANEL 2H (208V Units = 2, 230V Units = 1)		1 or 2
	1059-0571	ACCESS PANEL 2H CE (Control Side of 230V Units)		1
18	225173	HEYCO, SNAP BUSHING OCB-625	7	8
19	10280050	SCREW, 8-32 x 1-1/4 FL PH SS MACHINE		4
20	1059-0456	HS2, BASE PAN 2W		1
21	169629	SWITCH, SEALED CARLING		1
22	ELC0084	USB-A TO PANEL MOUNT USB-A (Replaced 225236)		1
	225236	USB ADAPTER		1
23	1059-0679	HS2, COVER, USB (Replaced 225237)		1
	225237	USB COVER		1
24	279500	SCREW, 8-32 x 1/2" PTHMS 18-8SS		A/R
25	1059-0394	HS2, BEZEL DAYPART MYLAR		1
26	225165	MYLAR DAYPART		1
27	1059-0750	HS2 MENU BAR 2W (Side Mount)	1	2
	1059-0474K	HS2 Menu Bar 2W (Front Mount - Replaced by 1059-0750 - 3/7/2017)	1	2
29	1059-0499	HS2, PAN STOP COVER		4
30	225238	HS2, Spacer Cover Stop		4
Not shown	600532	Kit, HS2 Cover Stop with 6-32 Nutsert Tool		1
31	156602	Pan, Single Handle		A/R
32	156634	Pan, Double Handle		A/R
33	E030951	Metal Trivet, 1/3 Size Pan		A/R
34	1059-0498	HS2 Pan Cover		A/R
35	166100	SPACER, TUBE NYLON 0.25 OD x 0.125 ID x 0.375 H		3
36	166184	USB. 2.0 MALE TO FEMALE RT. ANGLE ADAPTER		1
37	166101	SUPPORT, LOCK-IN PC		9
38	600517	Kit, Service, PCB, IO, HS2 (Ref, ELC0001-6)		1
39	166102	WASHER, 0.375 OD x 0.13ID x 0.062THK		1
40	1059-0384	HS2, BUZZER MTG BRKT		1
41	512766	BUZZER, ULTRA LOUD CONTINUOUS TONE		1
42	166114	TRIAC PCB ASY		1
43	ELC0332	ACM BOARD, PROGRAMMED, HS2 (Ref-ELC0120)		1
44	600351	Service Kit, 120011 Power Supply		1
45	120158	SPACER,NUT .375"		2
46	225219	Harness, timer bar exit, quad		1
47	225216	Day part harness		1
Not Shown	225221	HARNESS IDC 12V & CAN		1
Not shown	166105	JUMPER, HEAT TRIAC PCB		1
Not shown	225234	HARNESS MAIN AC – HS2		1
Not shown	166110	HARNESS, AC DMC 2X2		1
Not Shown	225220	Harness, timer bar exit, dual (T2R Models)	-	1

**Table: PL-1 TIMER BAR MODELS (HS2-22-2082/2302 T1R & T2R)**

## TIMER BAR MODELS (HS2-23-2084/2304 T1R & T2R)

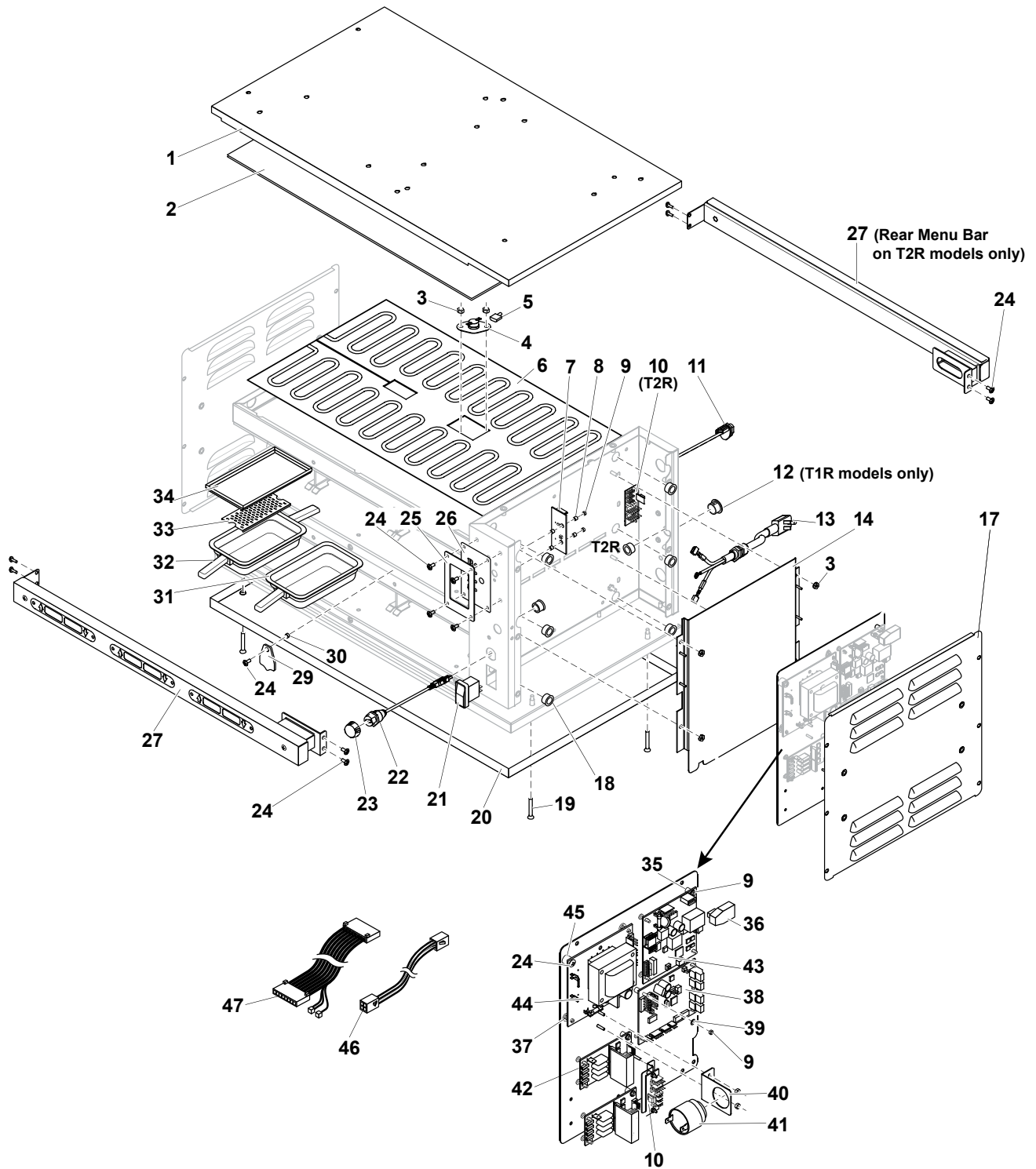

Figure: PL-2 TIMER BAR MODELS (HS2-23-2084/2304 T1R & T2R)

**TIMER BAR MODELS (HS2-23-2084/2304 T1R & T2R)**

ITEM	PN	DESCRIPTION	QTY	
			T1R - Models	T2R - Models
1	1059-0519	HS2, TOP 3W RF		1
2	1059-0255	INSULATION 1/8" 3W		1
3	155680	NUT, KEPS 8-32 HEX ZP		50
4	158312	THERMOSTAT, HI-LIMIT 300 DEG W/FLANGE		4
5	222603	WIRE, JUMPER HS2 HEAT ELEMENT COM.		4
6	225174	Heater, 2 Wide, 208/240V (4-Zone Units - After 3/1/2017)		4
	225257	Heater, 1 Wide, 208/240V (4-Zone Units - After 3/1/2017)		4
	225223	Heater, 3 Wide, 208/240V (2-Zone Units - Before 3/1/2017)		4
Not shown	158279	RTD, 1000 OHM-MEDIUM		A/R
7	225184	DUKE DAY PART PCB		1
8	225171	SPACER ROUND 1/4" X 1/8" IS DIA .115		4
9	223470	NUT, 4-40 NYLON LOCKNUT		9
10	225181	ASY, TIMER BAR 5V POWER PCB	1	2
11	118440	RJ45 ETHERNET CABLE, PANEL MOUNT (Replaced 118003 & 166111)		1
	166111	MODULAR, JACK IP67 (Replaced by 118003 -- 8/1/2017)		1
12	1059-0723	HS2, MENU BAR HOLE PLUG	1	-
13	222170	POWER CORD, 15A 250V, W/TERMINALS, 6' LG (208/240V Units)		1
	160448	POWER CORD, 16A 230V, W/TERMINALS, 8' LG (230V Units)		1
14	1059-0729	HS2, CRTL MTG PLATE 2H PEMS (Replaced 1059-0435)		1
16	1059-0727	HS2, ASY, DMC CRTL MTG PLT 2X3 4 Z (Replaced 1059-0537)		1
17	1059-0446	ACCESS PANEL 2H (208V Units = 2, 230V Units = 1)		1 or 2
	1059-0571	ACCESS PANEL 2H CE (Control Side of 230V Units)		1
18	225173	HEYCO, SNAP BUSHING OCB-625	7	8
19	10280050	SCREW, 8-32X1-1/4FL PH SS MACHINE		4
20	1059-0452	HS2, BASE PAN 3W		1
21	169629	SWITCH, SEALED CARLING		1
22	ELC0084	USB-A TO PANEL MOUNT USB-A (Replaced 225236)		1
	225236	USB ADAPTER		1
23	1059-0679	HS2, COVER, USB (Replaced 225237)		1
	225237	USB COVER		1
24	279500	SCREW, 8-32X1/2" PTHMS 18-8SS		46
25	1059-0394	HS2, BEZEL DAYPART MYLAR		1
26	225165	MYLAR DAYPART		1
27	1059-0719	HS2, Menu Bar, 3W (Side Mount)		
	1059-0443K	HS2, Menu Bar, 3W (Front Mount - Replaced by 1059-0719 - 3/7/2017)	1	2
29	1059-0499	HS2, PAN STOP COVER		8
30	225238	HS2, Spacer Cover Stop		8
Not shown	600532	Kit, HS2 Cover Stop with 6-32 Nutsert Tool		1
31	156602	Pan, Single Handle		1
32	156634	Pan, Double Handle		1
33	E030951	TRIVET, METAL, 1/3 SIZE PAN		6
34	1059-0498	HS2 Pan Cover		1
35	166100	SPACER, TUBE NYLON 0.25OD X 0.125ID X 0.375H		5
36	166184	USB. 2.0 MALE TO FEMALE RT. ANGLE ADAPTER		1
37	166101	SUPPORT, LOCK-IN PC		1
38	600517	Kit, Service, PCB, IO3, HS2 (Ref-ELC0001-6)		2
39	166102	WASHER, 0.375OD x 0.13ID x 0.062THK		2
40	1059-0384	HS2, BUZZER MTG BRKT		1
41	512766	BUZZER, ULTRA LOUD CONTINUOUS TONE		1
42	166114	TRIAC PCB ASY		2
43	ELC0332	ACM BOARD, PROGRAMMED, HS2 (Ref-ELC0120)		1
44	600352	KIT, SERVICE 225185 POWER SUPPLY		1
45	120158	SPACER, NUT .375"		2
46	225219	Harness, timer bar exit, quad	1	2
47	225216	Day part harness		1
Not shown	225221	HARNESS IDC 12V & CAN		1
Not shown	166105	JUMPER, HEAT TRIAC PCB		1
Not shown	225234	HARNESS MAIN AC – HS2		1
Not shown	166110	HARNESS, AC DMC 2X2		1

**Table: PL-2 TIMER BAR MODELS (HS2-23-2084/2304 T1R & T2R)**

## TIMER BAR MODELS (HS2-24-2084/2304 T1R & T2R)

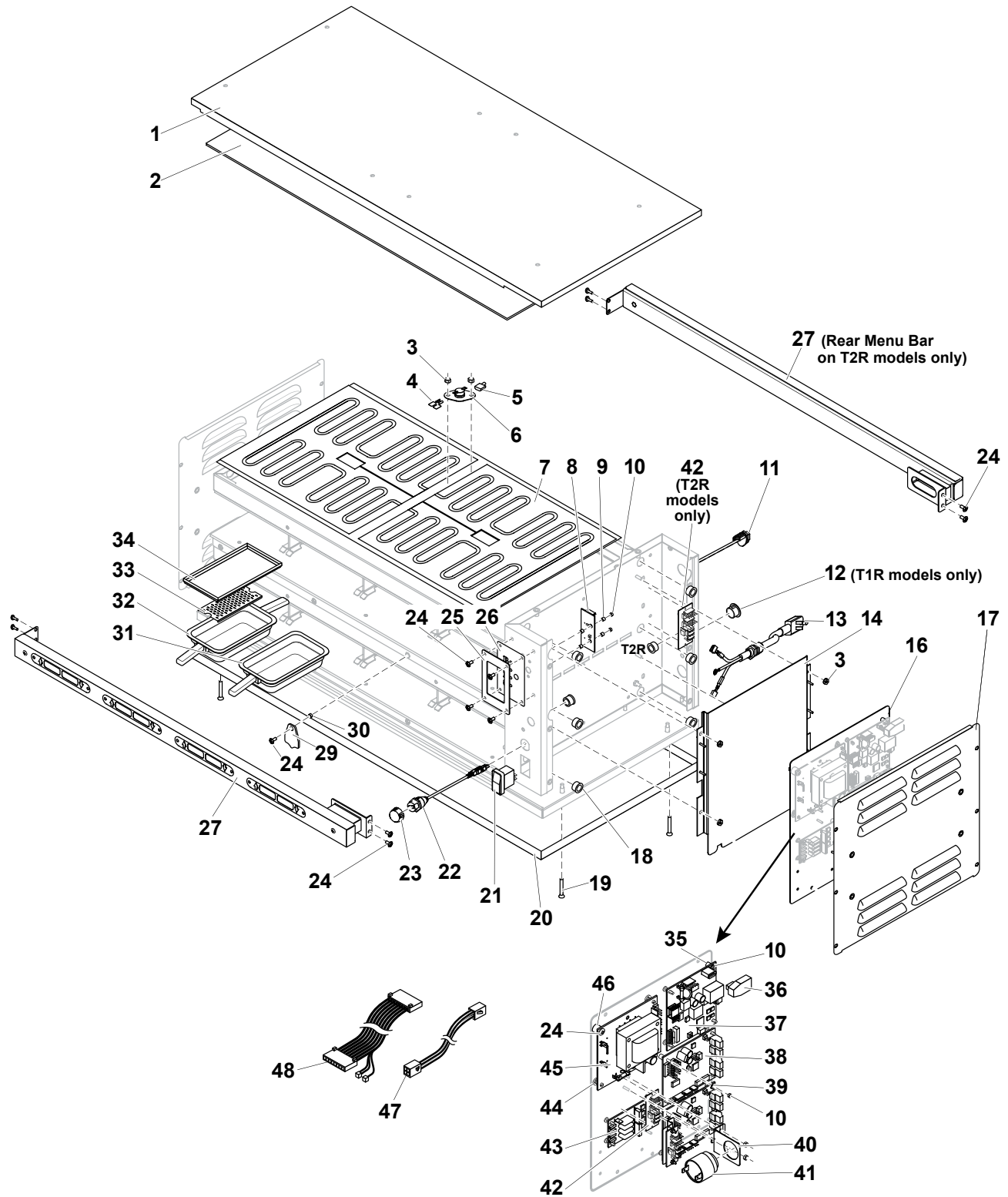

Figure: PL-3 TIMER BAR MODELS (HS2-24-2084/2304 T1R & T2R)



**TIMER BAR MODELS (HS2-24-2084/2304 T1R & T2R)**

ITEM	PN	DESCRIPTION	QTY	
			T1R-Models	T2R-Models
1	1059-0827	HS2, TOP 4W RF (Replaced 1059-0502)	1	
2	225180	INSULATION 1/8"	1	
3	155680	NUT,KEPS 8-32 HEX ZP	58	
4	512120	TERMINAL,MULTIPLIER - 34P2156	4	
5	222603	WIRE, JUMPER HS2 HEAT ELEMENT COM.	4	
6	158312	THERMOSTAT,HI-LIMIT 300 DEG W/FLANGE	4	
7	225174	Heater, 4 Wide 208/240V	8	
Not shown	158279	RTD, 1000 OHM-MEDIUM	A/R	
8	225184	DUKE DAY PART PCB	1	
9	225171	SPACER ROUND 1/4" X 1/8" IS DIA .115	4	
10	223470	NUT, 4-40 NYLON LOCKNUT	9	
11	118440	RJ45 Ethernet Cable, Panel Mount (Replaced 118003 & 166111)	1	
	166111	MODULAR, JACK IP67 (Replaced by 118003 -- 8/1/2017)	1	
12	1059-0723	HS2,MENU BAR HOLE PLUG	1	-
13	222170	POWER CORD, 15A 250V, W/TERMINALS, 6' LG (208/240V Units)	1	
	160448	POWER CORD, 16A 230V, W/TERMINALS, 8' LG (230V Units)	1	
14	1059-0729	HS2, ASY, CTRL VENT DUCT 2H (Replaced 1059-0435)	1	
16	1059-0829	HS2,CRTL MTG PLATE 2H PEMS (Replaced 1059-0537)	1	
17	1059-0446	ACCESS PANEL 2H (208/240V Units = 2)	1 or 2	
	1059-0571	ACCESS PANEL 2H CE (Control Side of 230V Units)	1	
18	225173	HEYCO, SNAP BUSHING OCB-625	7	8
19	10280050	SCREW,8-32X1-1/4FL PH SS MACHINE	4	
20	1059-0821	HS2, BASE PAN LEG MTG 4W (Replaced 1059-0339)	1	
21	169629	SWITCH,SEALED CARLING	1	
22	ELC0084	USB-A TO PANEL MOUNT USB-A	1	
	225236	USB ADAPTER (Replaced by ELC0084)	1	
23	1059-0679	HS2, COVER, USB	1	
	225237	USB COVER (Replaced by 1059-0679)	1	
24	279500	SCREW,8-32X1/2" PTHMS 18-8SS	A/R	
25	1059-0394	HS2, BEZEL DAYPART MYLAR	1	
26	225165	MYLAR DAYPART	1	
27	1059-0714	HS2, MENU BAR 4W (Side Mount)	1	2
	1059-0210	HS2 Menu Bar 4W (Front Mount-Replaced by 1059-0714, 2/16/2017)	1	2
29	1059-0499	HS2, PAN STOP COVER	8	
30	225238	HS2, Spacer Cover Stop	8	
Not shown	600532	Kit, Cover Stop with 10-32 Nutsert Tool	1	
31	156602	Pan, Single Handle	1	
32	156634	Pan, Double Handle	1	
33	E030951	TRIVET, METAL, 1/3 SIZE PAN	6	
34	1059-0498	HS2 Pan Cover	1	
35	166100	SPACER, TUBE NYLON 0.25OD x 0.125ID x 0.375H	5	
36	166184	USB. 2.0 MALE TO FEMALE RT. ANGLE ADAPTER	1	
37	ELC0332	ACM BOARD, PROGRAMMED, HS2 (Ref - ELC0120)	1	
	ELC0345	ACM BOARD, PROGRAMMED, HS2 INDIA (Ref-ELC0228)	1	
38	600517	Kit, Service, PCB, IO3, HS2 (Ref-ELC0001-6)	2	
39	166102	WASHER, 0.375OD x 0.13ID x 0.062THK	2	
40	1059-0384	HS2, BUZZER MTG BRKT	1	
41	512766	BUZZER, ULTRA LOUD CONTINUOUS TONE	1	
42	225181	ASY, TIMER BAR 5V POWER PCB	1	2
43	166114	TRIAC PCB ASY	2	
44	166101	SUPPORT,LOCK-IN PC	15	
45	600352	KIT, SERVICE 225185 POWER SUPPLY	1	
46	120158	SPACER,NUT .375"	2	
47	225219	Harness, timer bar exit, quad	1	
48	225216	Day part harness	1	
Not shown	225221	HARNESS IDC 12V & CAN	1	
Not shown	166105	JUMPER,HEAT TRIAC PCB	1	
Not shown	225234	HARNESS MAIN AC – HS2	1	
Not shown	166110	HARNESS,AC DMC 2X2	1	

**Table: PL-3 TIMER BAR MODELS (HS2-24-2084/2304 T1R & T2R)**

## TIMER BAR MODELS (HS2-34-2086/2306 T1R & T2R)

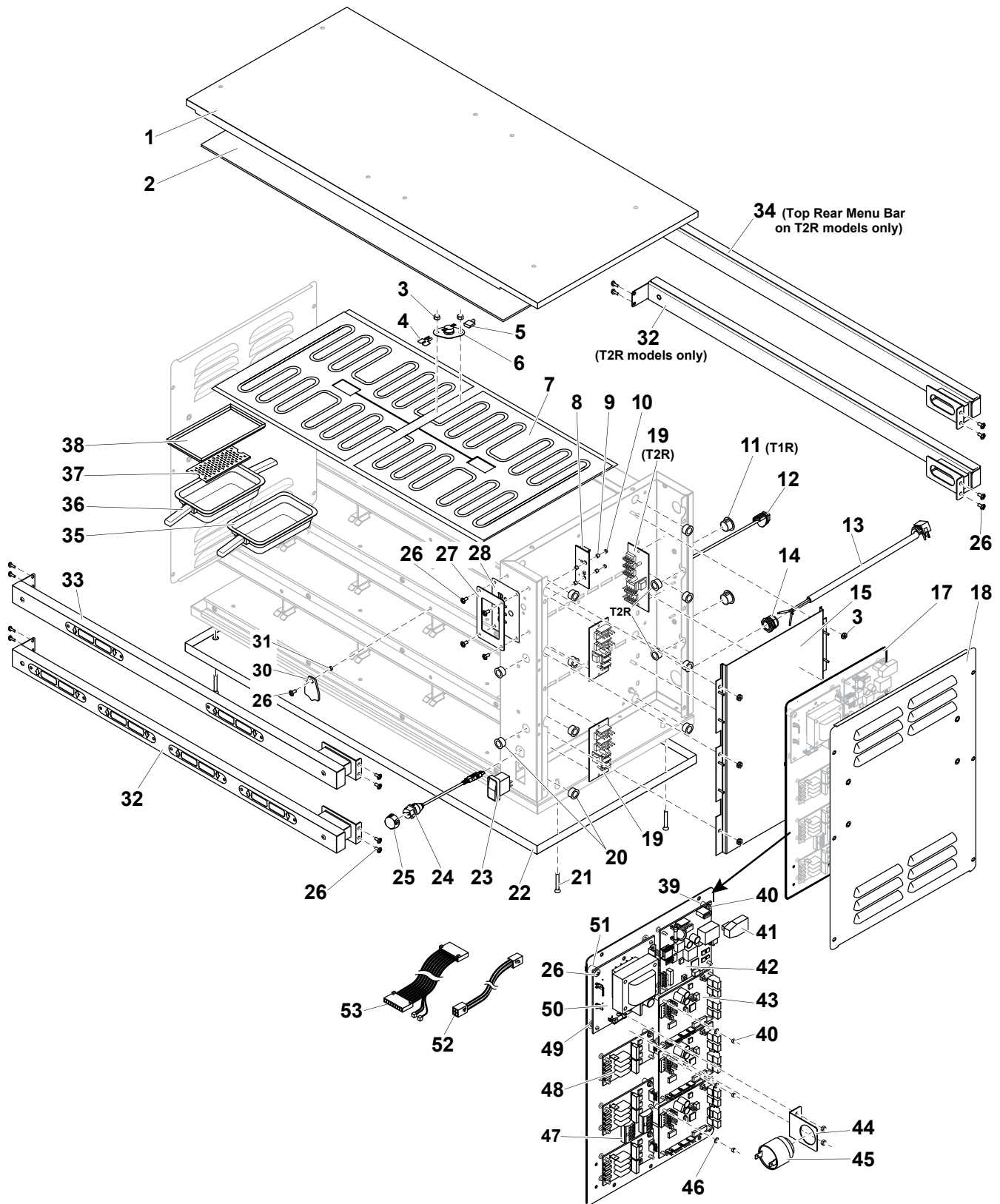

Figure: PL-4 TIMER BAR MODELS (HS2-34-2086/2306 T1R & T2R)

**TIMER BAR MODELS (HS2-34-2086/2306 T1R & T2R)**

ITEM	PN	DESCRIPTION	QTY	
			T1R-MDLS	T2R-MDLS
1	1059-0827	HS2, TOP 4W <i>(Replaced 1059-0502)</i>		1
2	225180	INSULATION 1/8"		1
3	155680	NUT, KEPS 8-32 HEX ZP		68
4	512120	TERMINAL,MULTIPLIER - 34P2156		6
5	222603	WIRE, JUMPER HS2 HEAT ELEMENT COM.		6
6	158312	THERMOSTAT,HI-LIMIT 300 DEG W/FLANGE		6
7	225174	Heater, 4 Wide 208/240V		12
Not shown	158279	RTD, 1000 OHM-MEDIUM		A/R
8	225184	DUKE DAY PART PCB		1
9	225171	SPACER ROUND 1/4" x 1/8" IS DIA .115		4
10	223470	NUT, 4-40 NYLON LOCKNUT		11
11	1059-0723	HS2,MENU BAR HOLE PLUG	2	-
12	118440	RJ45 Ethernet Cable, Panel Mount <i>(Replaced 118003 &amp; 166111)</i>		1
	166111	MODULAR, JACK IP67 <i>(Replaced by 118003 -- 8/1/2017)</i>		1
13	166070	CORD POWER 20 AMP 208/240, W/TERMIANLS, 6-1/2' LG		1
	160448	POWER CORD, 16A 230V, W/TERMINALS, 8' LG <i>(230V Units)</i>		1
14	160486	STRAIN RELIEF,CORD		1
15	1059-0781	HS2, CRTL MTG PLATE 3H PEMS <i>(Replaced 1059-0420)</i>		1
17	1059-0782	HS2, ASY, DMC CRTL MTG PLATE <i>(Replaced 1059-0536)</i>		1
18	1059-0385	HS2, ASY ACCESS PANEL 3H <i>(208/240V Units = 2)</i>		1 or 2
	1059-0546	ACCESS PANEL 3H CE <i>(Control Side of 230V Units)</i>		1
19	225181	ASY, TIMER BAR 5V POWER PCB	2	3
20	225173	HEYCO, SNAP BUSHING OCB-625	10	12
21	10280050	SCREW,8-32X1-1/4FL PH SS MACHINE		4
22	1059-0821	HS2, BASE PAN LEG MTG 4W <i>(Replaced 1059-0339)</i>		1
23	169629	SWITCH, SEALED CARLING		1
24	ELC0084	USB-A TO PANEL MOUNT USB-A		1
	225236	USB ADAPTER <i>(Replaced by ELC0084)</i>		1
25	1059-0679	HS2, COVER, USB		1
	225237	USB COVER <i>(Replaced by 1059-0679)</i>		1
26	279500	SCREW, 8-32 x 1/2" PTHMS 18-8SS		54
27	1059-0394	HS2, BEZEL DAYPART MYLAR		1
28	225165	MYLAR DAYPART		1
30	1059-0499	HS2, PAN STOP COVER		12
31	225238	HS2, Spacer Cover Stop		12
Not Shown	600532	Kit, Cover Stop with 10-32 Nutsert Tool		1
32	1059-0714	HS2, MENU BAR 4W <i>(Side Mount)</i>	1	2
	1059-0210K	HS2 Menu Bar 4W <i>(Front Mount-Replaced by 1059-0714, 2/16/17)</i>	1	2
33	1059-0713	HS2, TOP MENU BAR 4W <i>(Side Mount)</i>	1	1
	1059-0209	HS2, Top Menu Bar 4W <i>(Front Mount-Replaced by 1059-0713, 2/16/17)</i>	1	1
34	1059-0726	HS2, TOP REAR MENU BAR 4W <i>(Side Mount)</i>	-	1
	1059-0475K	HS2, Top Rear Menu Bar 4W <i>(Front Mount-Replaced by 1059-0726, 2/16/17)</i>	-	1
35	156602	Pan, Single Handle		1
36	156634	Pan, Double Handle		1
37	E030951	TRIVET, METAL, 1/3 SIZE PAN		4
38	1059-0498	HS2,PAN COVER		8
39	166100	SPACER,TUBE NYLON 0.25OD X 0.125ID X 0.375H		7
40	223470	NUT, 4-40 NYLON LOCKNUT		7
41	166184	USB. 2.0 MALE TO FEMALE RT. ANGLE ADAPTER		1
42	ELC0332	ACM BOARD, PROGRAMMED, HS2 <i>(Ref - ELC0120)</i>		1
43	600517	Kit, Service, PCB, IO3, HS2		3
44	1059-0384	HS2, BUZZER MTG BRKT		1
45	512766	BUZZER, ULTRA LOUD CONTINUOUS TONE		1
46	166102	WASHER,0.375OD X 0.13ID X 0.062THK		1
47	212106	CONNECTOR WAGO 5 CONDUCTOR 222-415		2
48	166114	TRIAC PCB ASY		3
49	166101	SUPPORT, LOCK-IN PC		21
50	600352	Kit, Service 225185 Power Supply		1
51	120158	SPACER,NUT .375"		2
52	225219	Harness, timer bar exit, quad	2	3
53	225216	Day part harness		1
Not shown	225221	HARNESS IDC 12V & CAN		1
Not shown	166105	JUMPER,HEAT TRIAC PCB		3
Not shown	166109	HARNESS,AC DMC 2X4	-	1
Not shown	166104	JUMPER,IO TO IO	-	1
Not shown	225220	Harness, timer bar exit, dual	-	1
Not Shown	225220	Harness, timer bar exit, dual <i>(T2R Models)</i>	-	1

**Table: PL-4 TIMER BAR MODELS (HS2-34-2086/2306 T1R & T2R)**

## TIMER BAR MODELS (HS2-42-2084/2304 T1R & T2R)

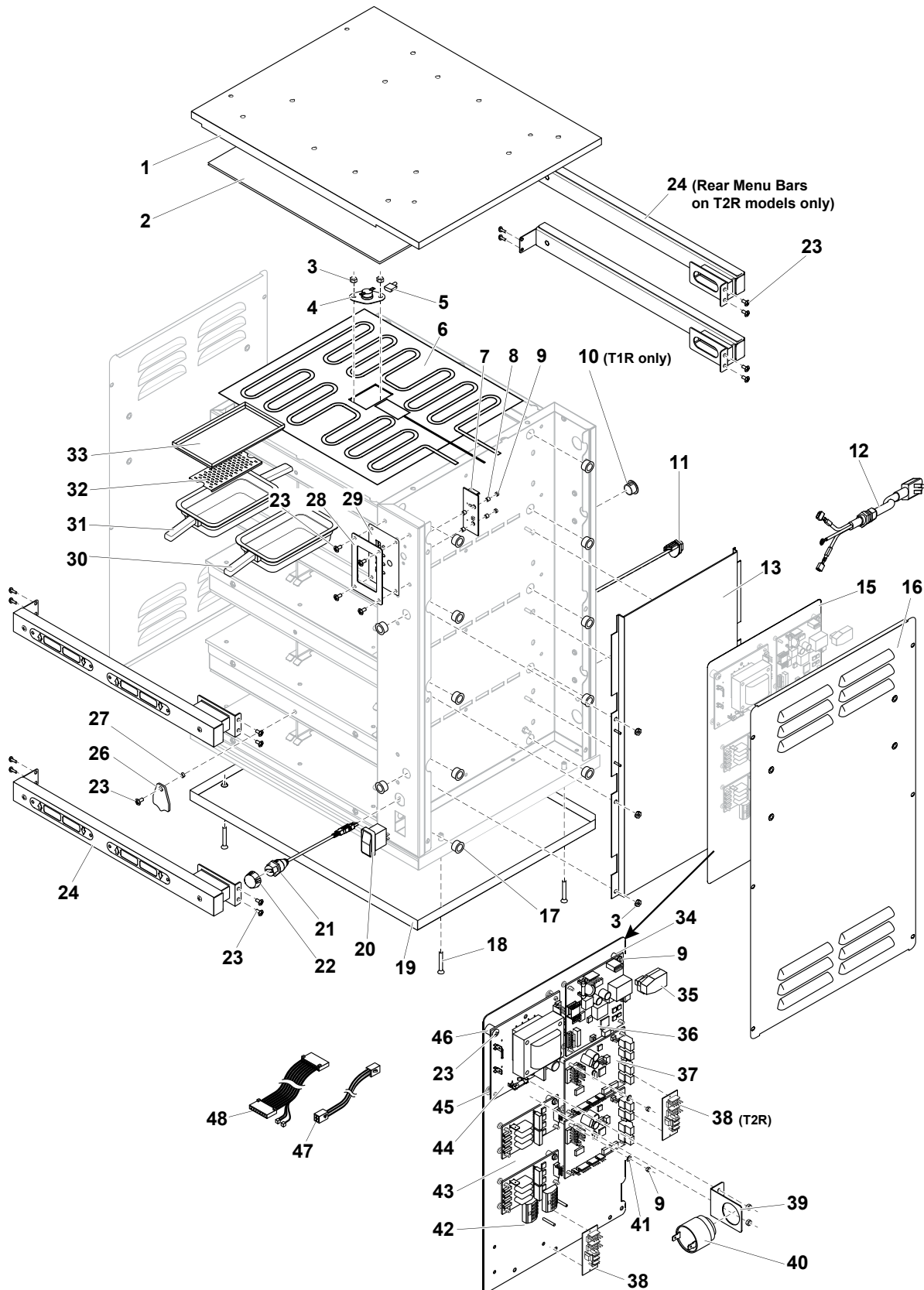

Figure: PL-5 TIMER BAR MODELS (HS2-42-2084/2304 T1R & T2R)

## TIMER BAR MODELS (HS2-42-2084/2304 T1R & T2R)

ITEM	PN	DESCRIPTION	QTY	
			T1R - Models	T2R Models
1	1059-0521	HS2, TOP 2W RF		1
2	1059-0528	HS2, INSULATION 1/8" 2W		1
3	155680	NUT, KEPS 8-32 HEX ZP		60
4	158312	THERMOSTAT, HI-LIMIT 300 DEG W/FLANGE		8
5	222603	WIRE, JUMPER HS2 HEAT ELEMENT COM.		8
6	225225	Heater, 2 Wide 208/240V		8
Not shown	158279	RTD, 1000 OHM-MEDIUM		A/R
7	225184	DUKE DAY PART PCB		1
8	225171	SPACER ROUND 1/4" X 1/8" IS DIA .115		12
9	223470	NUT, 4-40 NYLON LOCKNUT		9
10	1059-0723	HS2, MENU BAR HOLE PLUG	2	-
11	118440	RJ45 Ethernet Cable, Panel Mount (Replaced 118003 & 166111)		1
	166111	MODULAR, JACK IP67 (Replaced by 118003 -- 8/1/2017)		1
12	222170	CORD POWER 15 AMP 208/240V		1
	160448	CORD POWER 16 AMP 230V IEC60309		1
13	1059-0781	CONTROL MOUNTING PANEL ASSY (Replaced 1059-0531)		1
15	1059-0751	CONTROL MOUNTING PLATE ASSY (Replaced 1059-0536)		1
16	1059-0495	ACCESS PANEL 4H (208/240V Units = 2)		1 or 2
	1059-0574	ACCESS PANEL 4H CE (Control Side of 230V Units)		1
17	225173	HEYCO, SNAP BUSHING OCB-625	12	14
18	10280050	SCREW, 8-32X1-1/4FL PH SS MACHINE		4
19	1059-0456	HS2, BASE PAN 2W		1
20	169629	SWITCH, SEALED CARLING		1
21	ELC0084	USB-A TO PANEL MOUNT USB-A		1
	225236	USB ADAPTER (Replaced by ELC0084)		1
22	1059-0679	HS2, COVER, USB		1
	225237	USB COVER (Replaced by 1059-0679)		1
23	279500	SCREW, 8-32 x 1/2" PTHMS 18-8SS		50
24	1059-0750	MENU BAR 2W (Side Mount)	2	4
	1059-0474K	MENU BAR 2W (Front Mount-Replaced by 1059-0750 - 3/7/2017)	2	4
26	1059-0499	HS2, PAN STOP COVER		8
27	225238	HS2, Spacer Cover Stop		8
Not Shown	600532	Kit, Cover Stop with 10-32 Nutsert Tool		1
28	1059-0394	HS2, BEZEL DAYPART MYLAR		1
29	225165	MYLAR DAYPART		1
30	156602	Pan, Single Handle		1
31	156634	Pan, Double Handle		1
32	E030951	TRIVET, METAL, 1/3 SIZE PAN		2
33	1059-0498	HS2, PAN COVER		6
34	166100	SPACER, TUBE NYLON 0.25OD X 0.125ID X 0.375H		1
35	166184	USB. 2.0 MALE TO FEMALE RT. ANGLE ADAPTER		1
36	ELC0332	ACM BOARD, PROGRAMMED, HS2 (Ref - ELC0120)		1
37	600517	Kit, Service, PCB, IO3, HS2		2
38	225181	ASY, TIMER BAR 5V POWER PCB	1	2
39	1059-0384	HS2, BUZZER MTG BRKT		1
40	512766	BUZZER, ULTRA LOUD CONTINUOUS TONE		1
41	166102	WASHER, 0.375OD X 0.13ID X 0.062THK		2
42	212106	CONNECTOR WAGO 5 CONDUCTOR 222-415		2
43	166114	TRIAC PCB ASY		2
44	600352	Kit, Service 225185 Power Supply		1
45	166101	SUPPORT, LOCK-IN PC		15
46	120158	SPACER, NUT .375"		2
47	225219	Harness, timer bar exit, quad	2	4
48	225216	Day part harness		1
Not shown	225221	HARNES IDC 12V & CAN		1
Not shown	166105	JUMPER, HEAT TRIAC PCB		2
Not shown	225234	HARNES MAIN AC – HS2		1
Not shown	225255	HS2 AC 4X2		1

Table: PL-5 TIMER BAR MODELS (HS2-42-2084/2304 T1R & T2R)

# WIRING DIAGRAMS

## HS2-22, 2-Zone Models

### WIRING DIAGRAM 2x2 HS2

225247 Rev. C 6/1/17

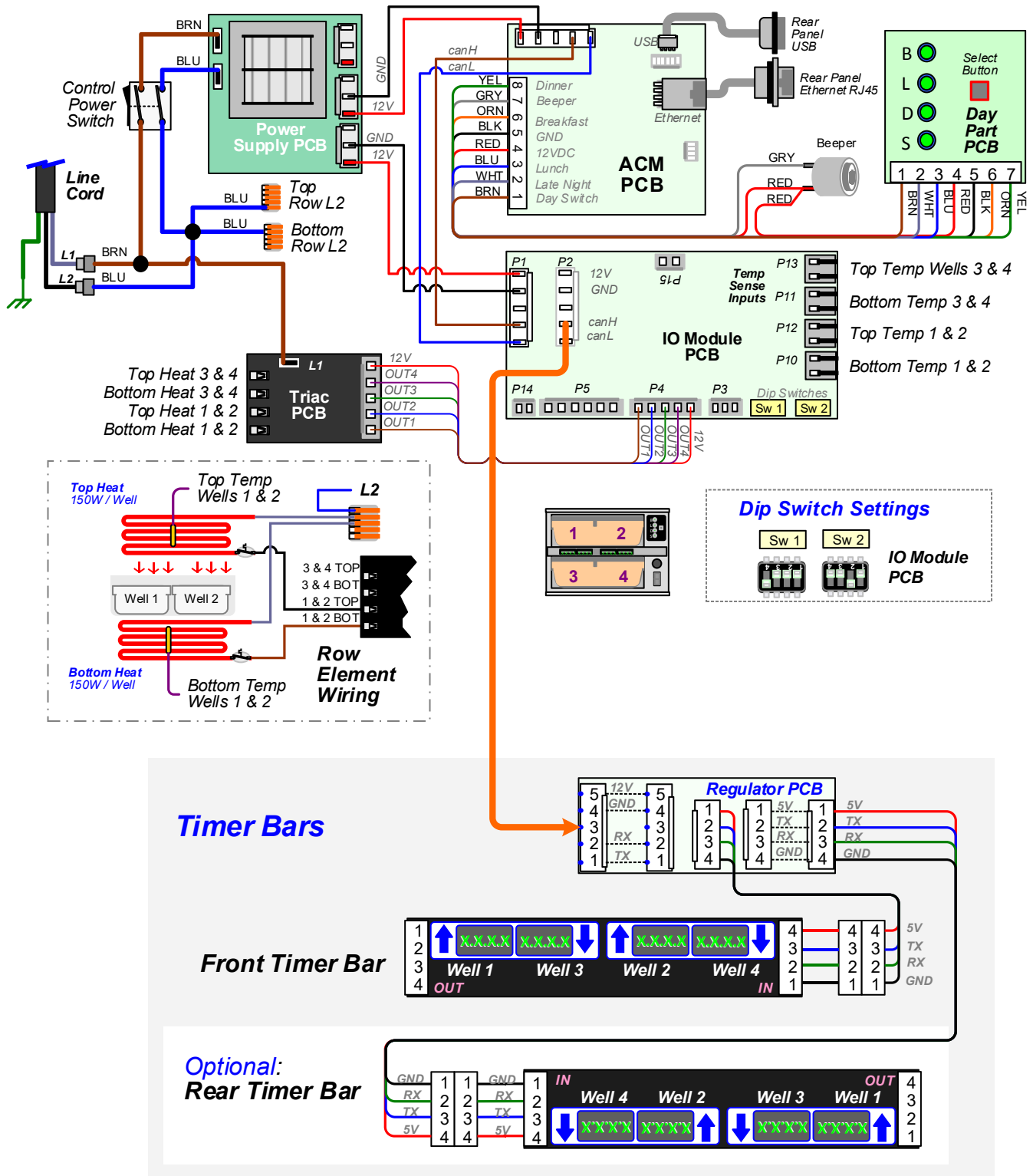

# WIRING DIAGRAMS

## HS2-23, 2-Zone Models

### WIRING DIAGRAM 2x3 HS2

225246 Rev. B 6/1/17

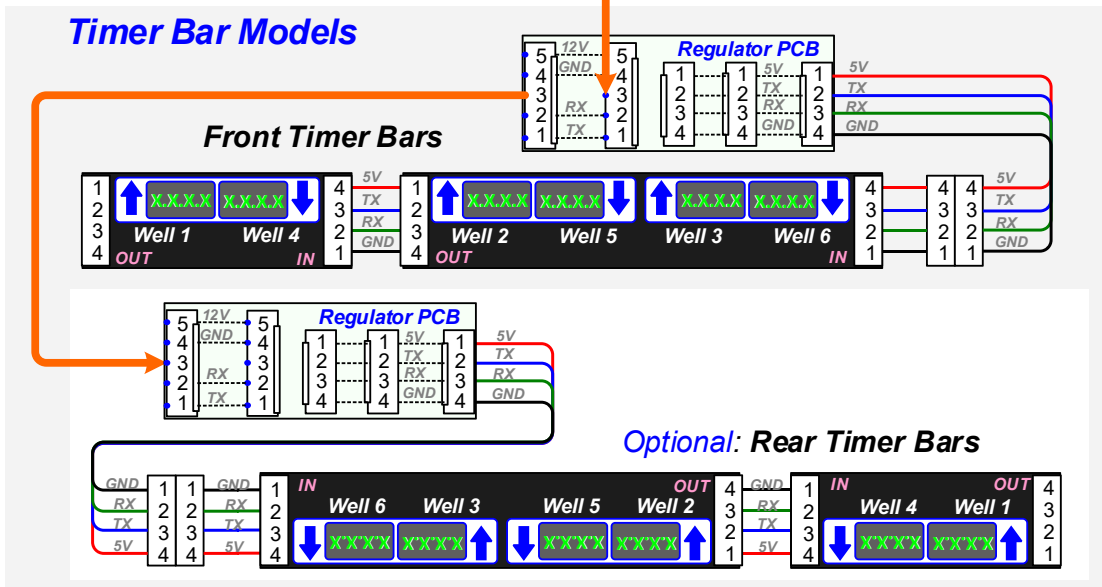
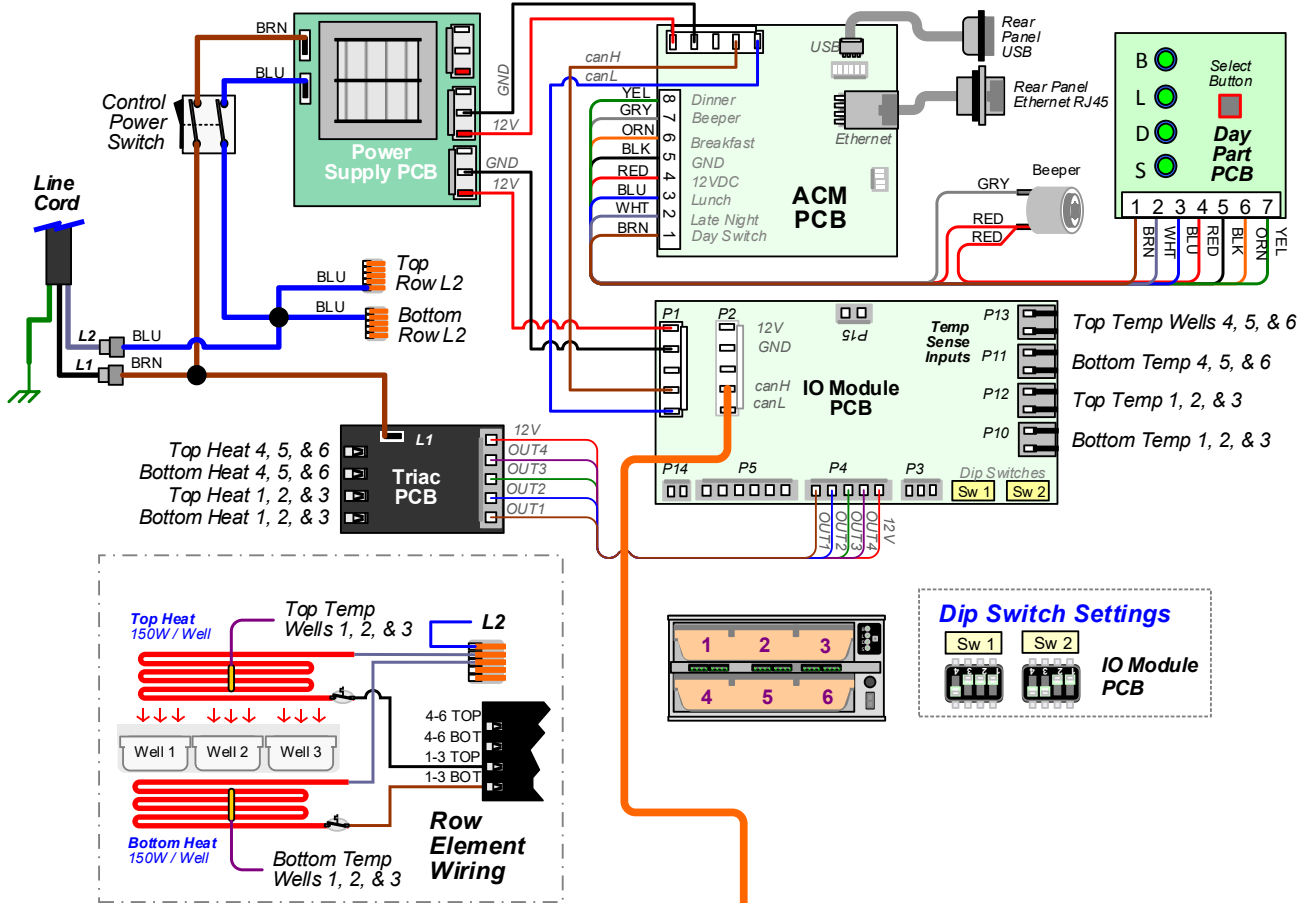

# WIRE DIAGRAM

## HS2-23, 4-Zone Models

### Wire Diagram - HS2 Zoned 2 x 3

ELC0131 Rev. B (2x3\_4z) 6/1/17

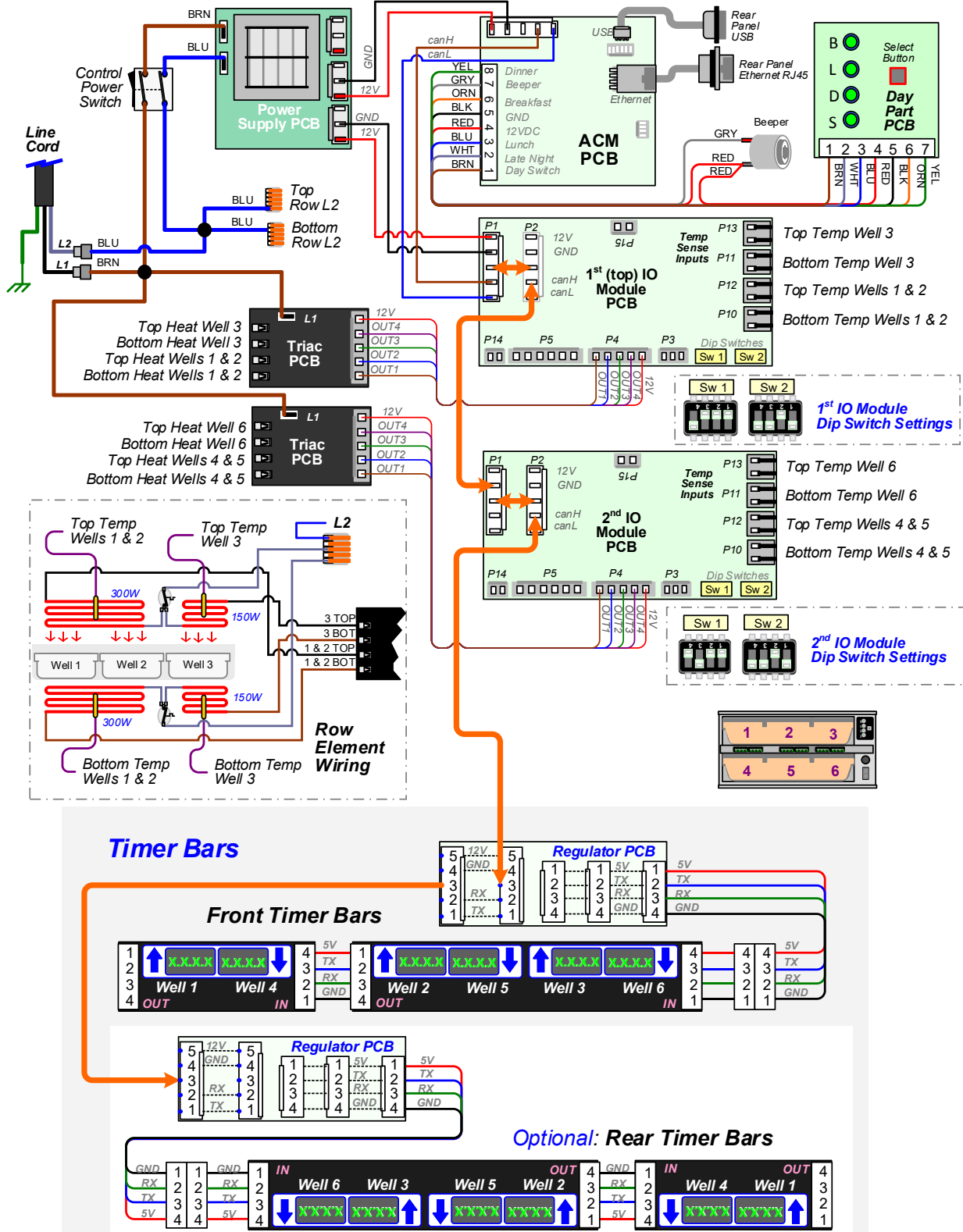



# WIRE DIAGRAM

## HS2-24, 4-Zone Models

**WIRING DIAGRAM 2x4 HS2**  
225245 Rev. B 6/1/17

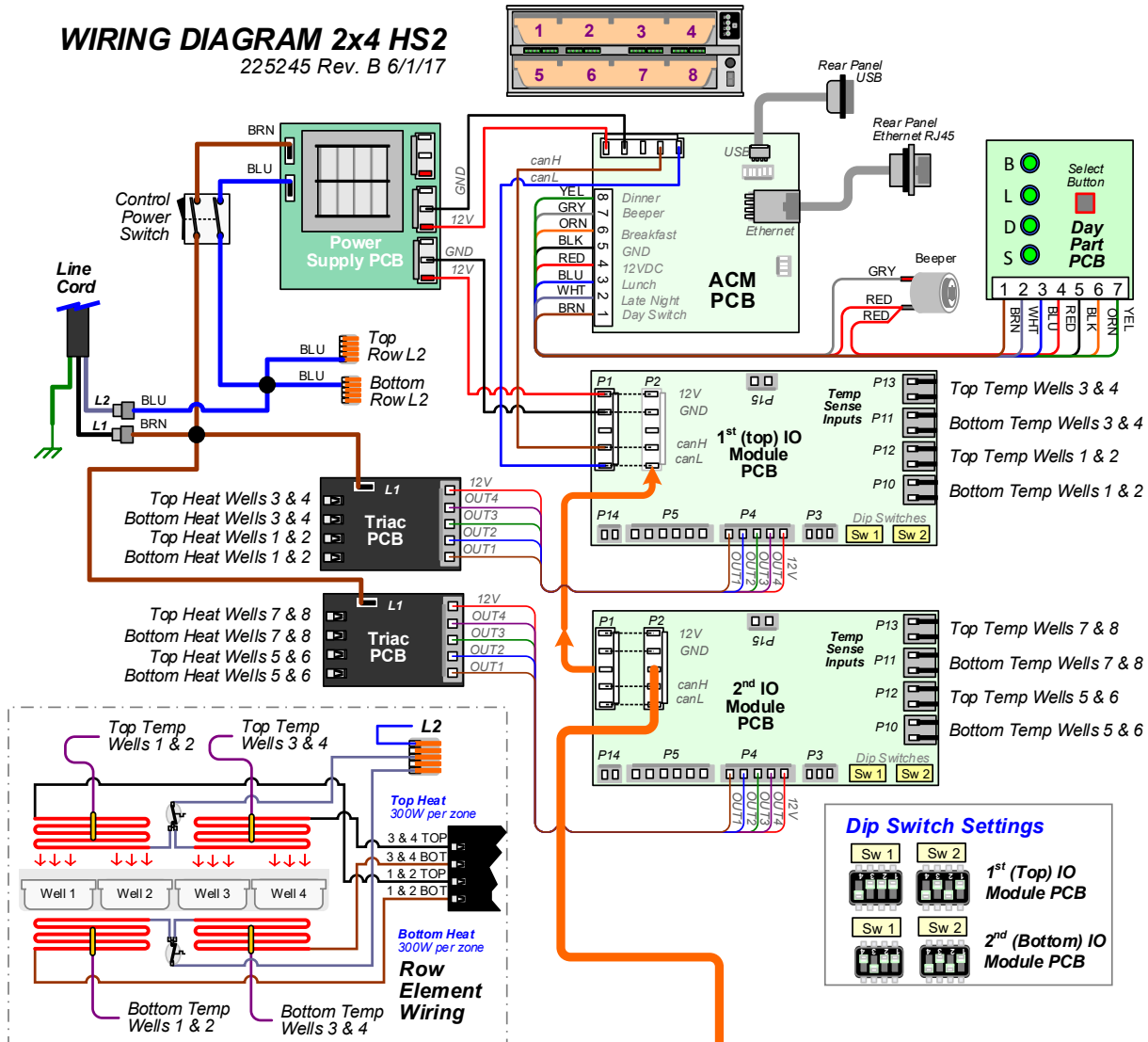

### Timer Bars

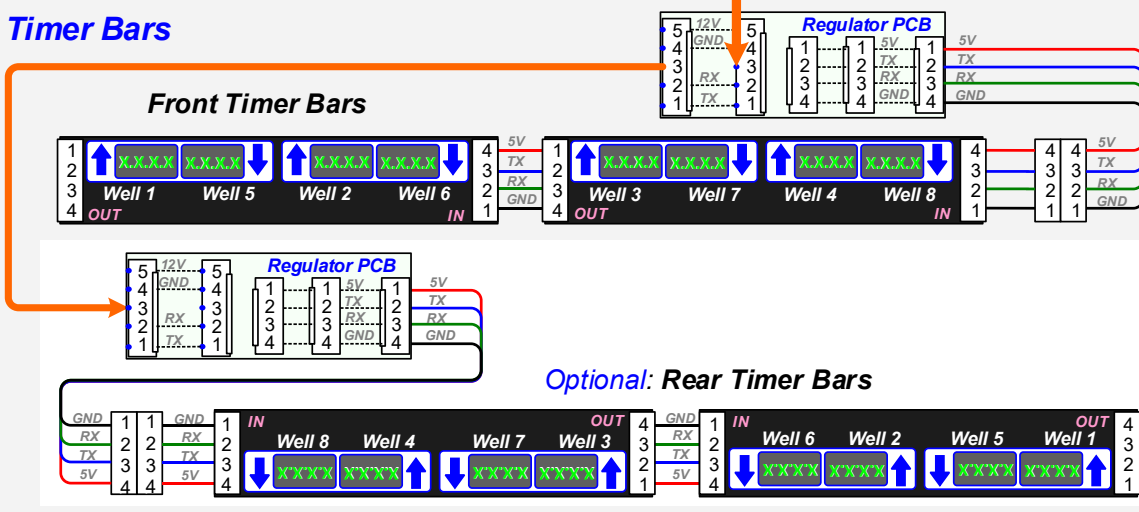

# WIRE DIAGRAM

## HS2-34, 6-Zone Models

### WIRING DIAGRAM 3x4 HS2

225244 Rev. C 6/1/17

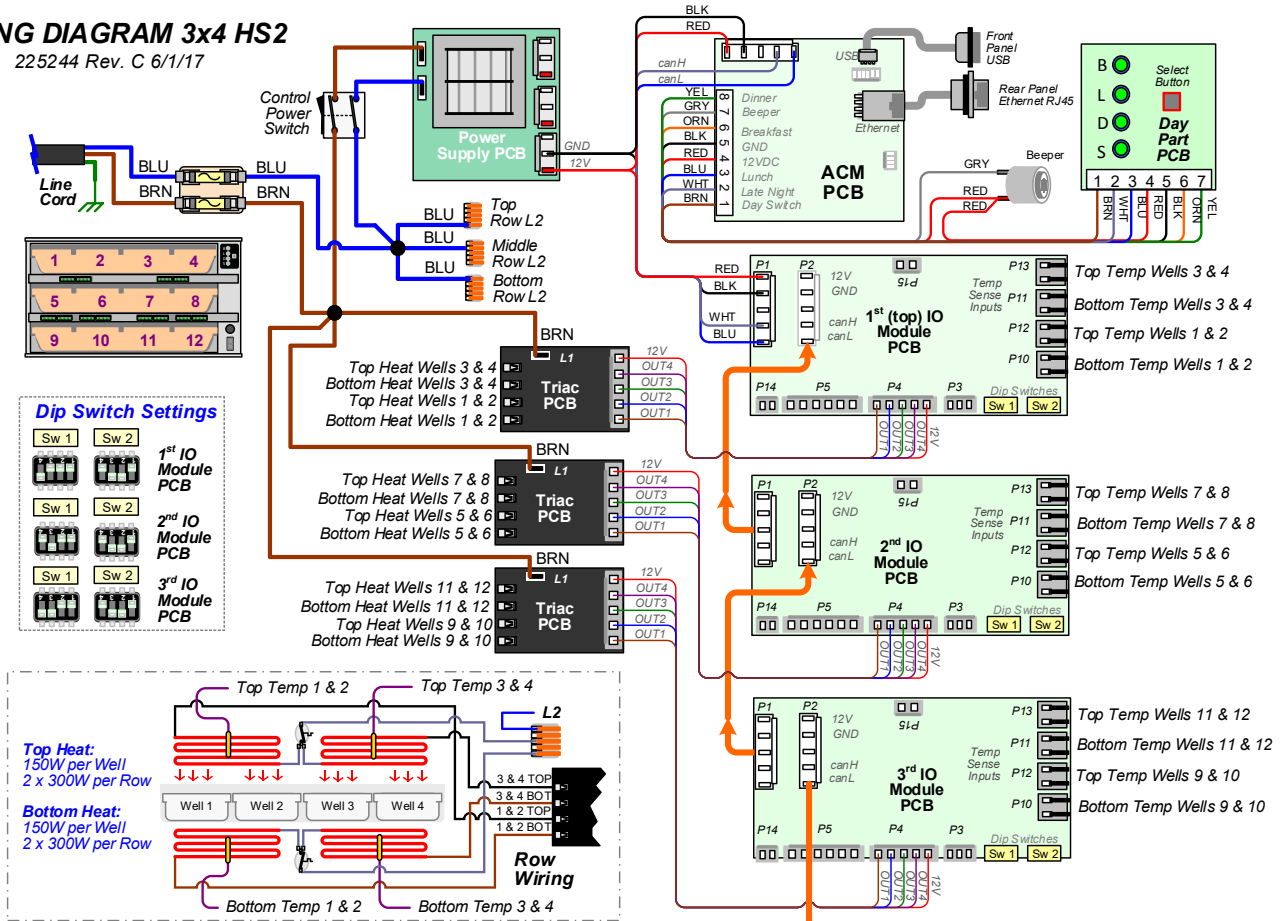

### Timer Bars

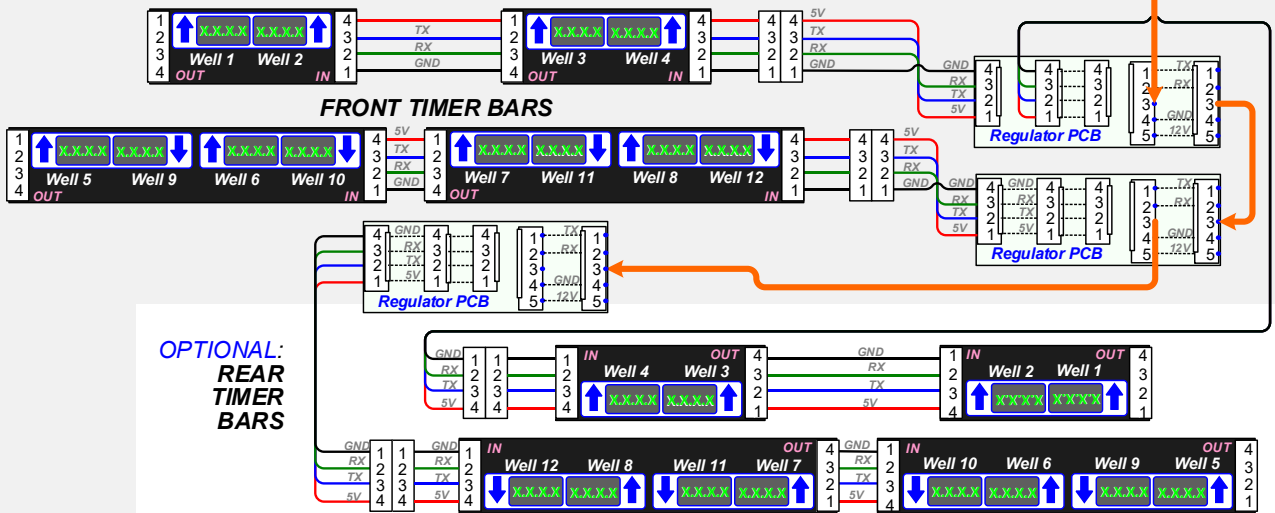

# WIRE DIAGRAM

## HS2-42, 4-Zone Models

**WIRING DIAGRAM 4x2 HS2** 225253 Rev. C 6/1/17

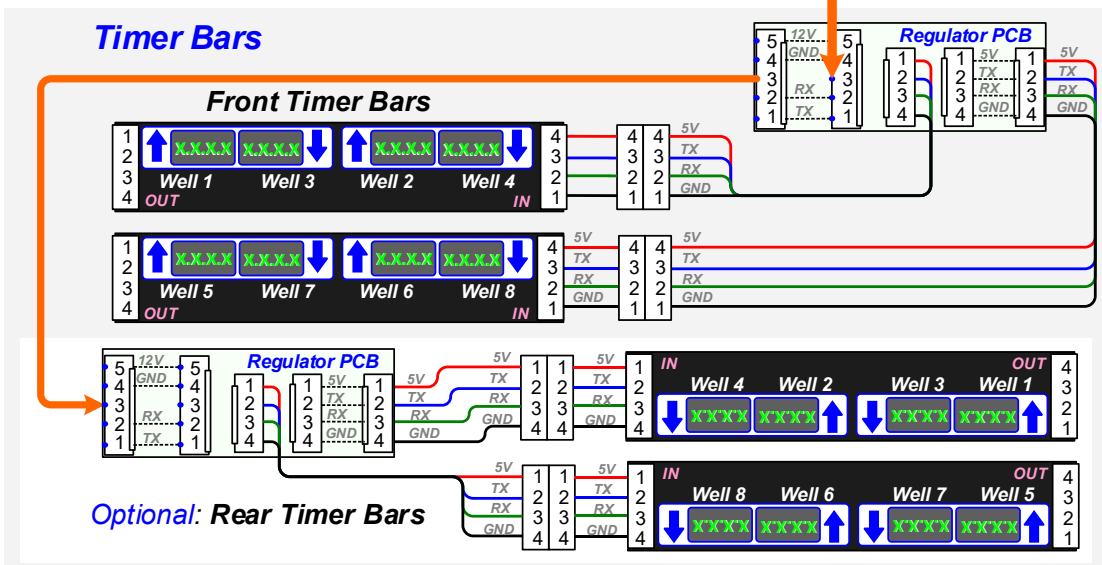
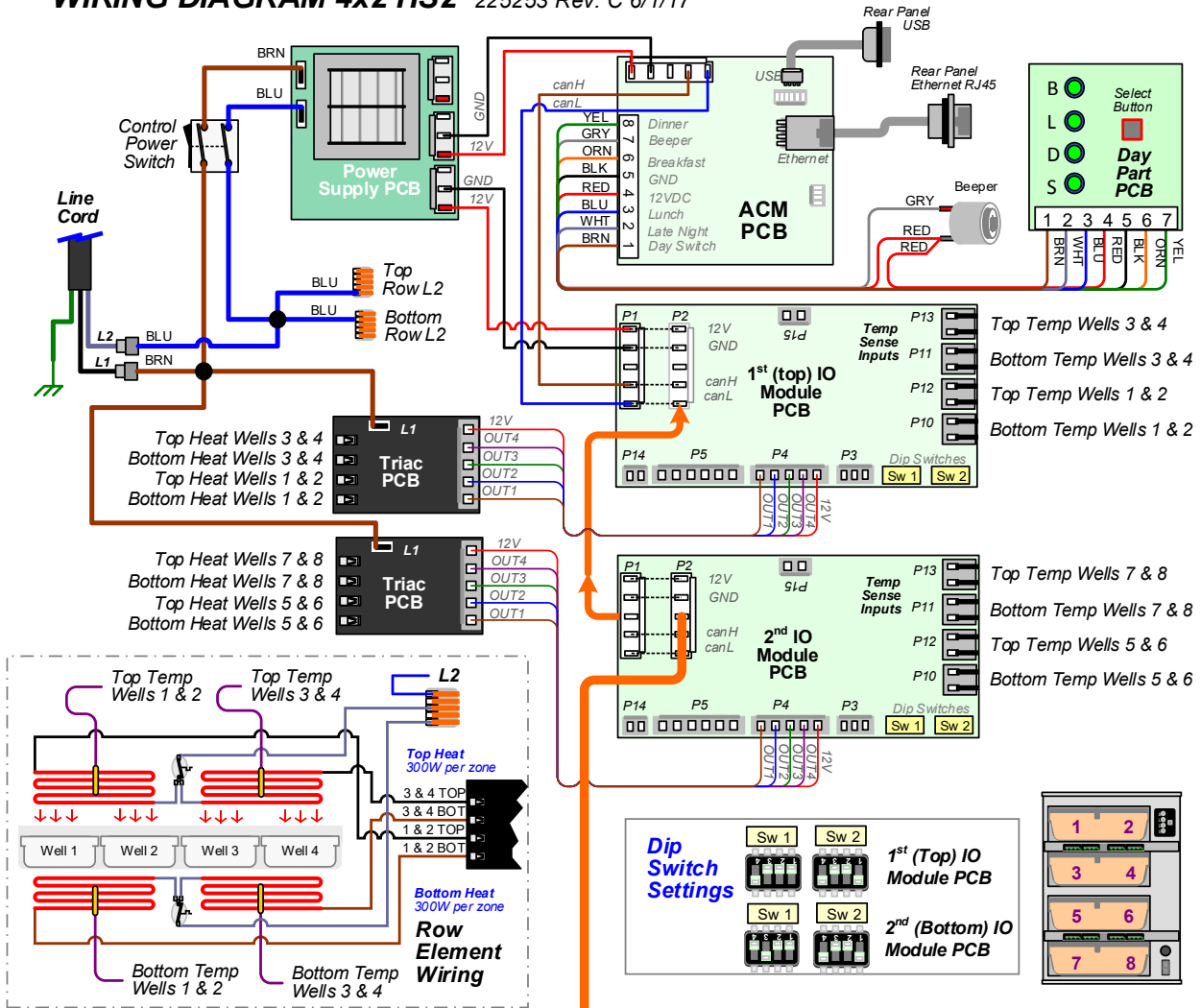

# WIRE DIAGRAM

## HS2-22, 2-Zone CE Models

### WIRING DIAGRAM 2x2 HS2 - CE

ELC0229 Rev. A 9/22/17

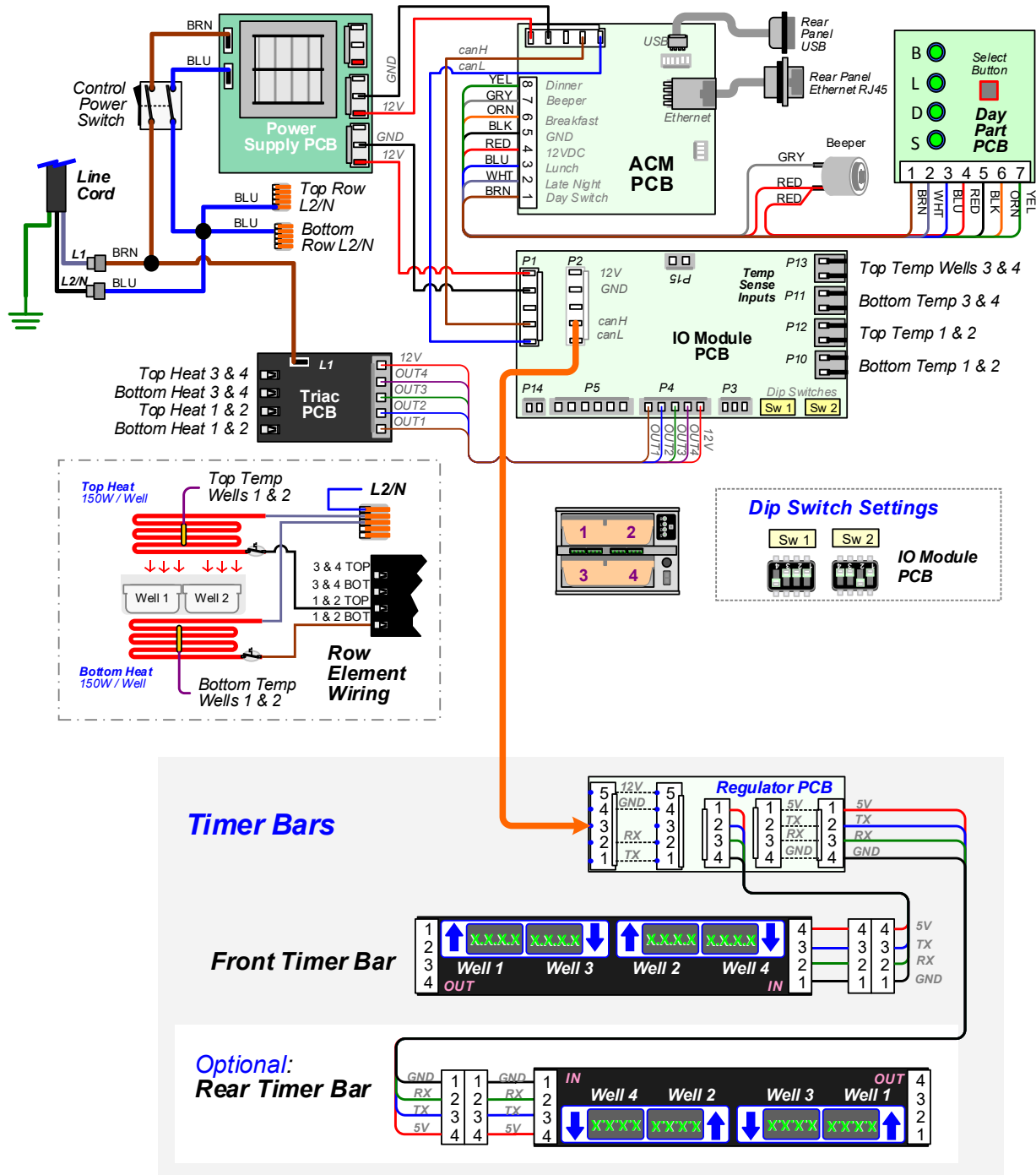

# WIRE DIAGRAM

## HS2-23, 4-Zone CE Models

### Wire Diagram - HS2 Zoned 2 x 3 - CE

ELC0230 Rev. A (2x3\_4z) 9/27/17

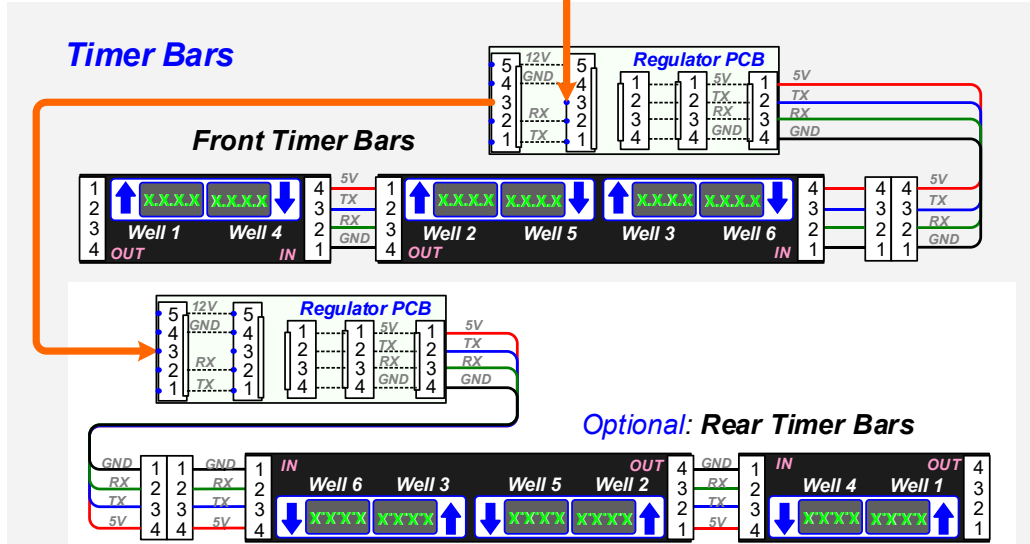
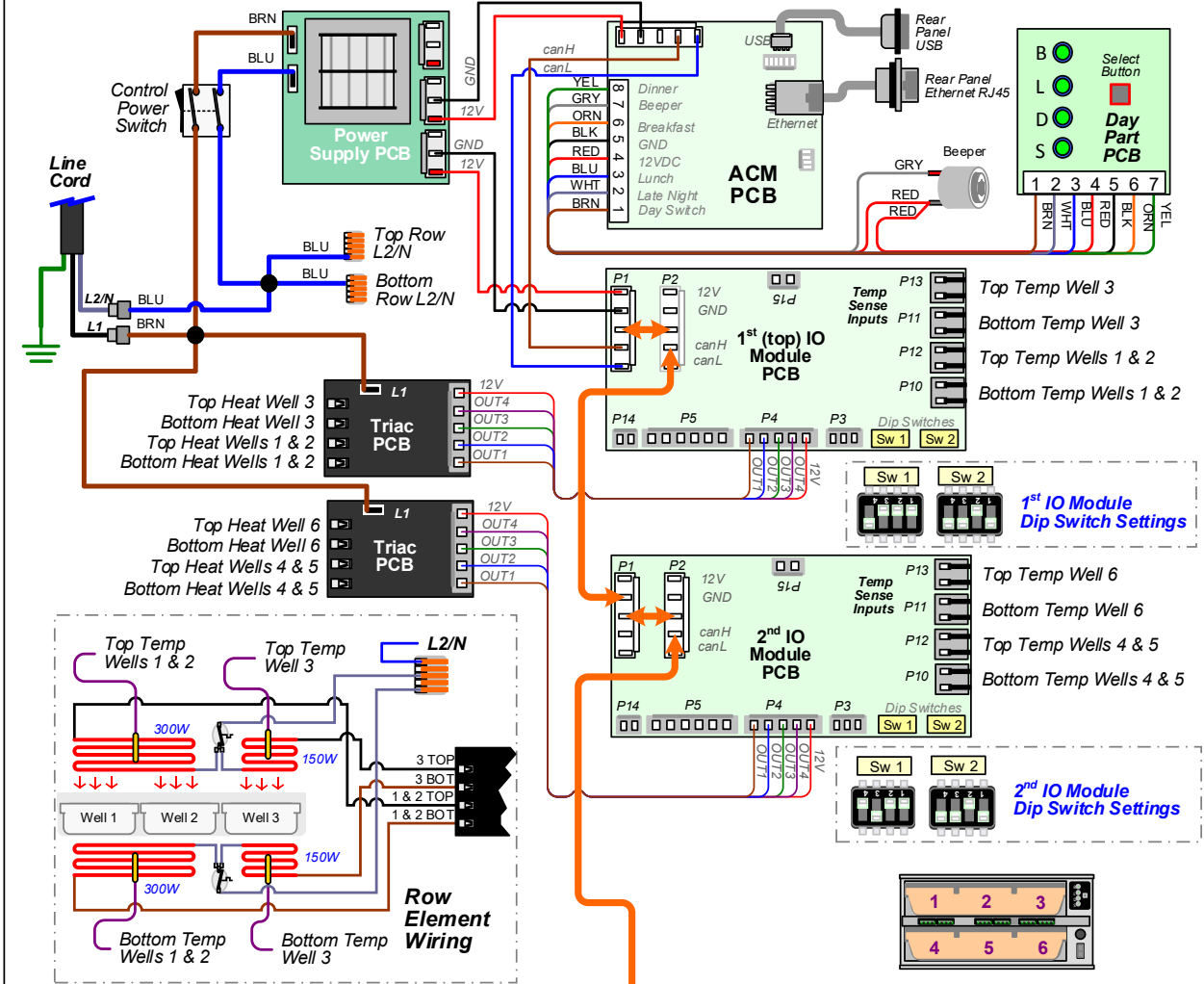

# WIRE DIAGRAM

## HS2-24, 4-Zone CE Models

**WIRING DIAGRAM 2x4 HS2 - CE**  
ELC0231 Rev. A 9/22/17

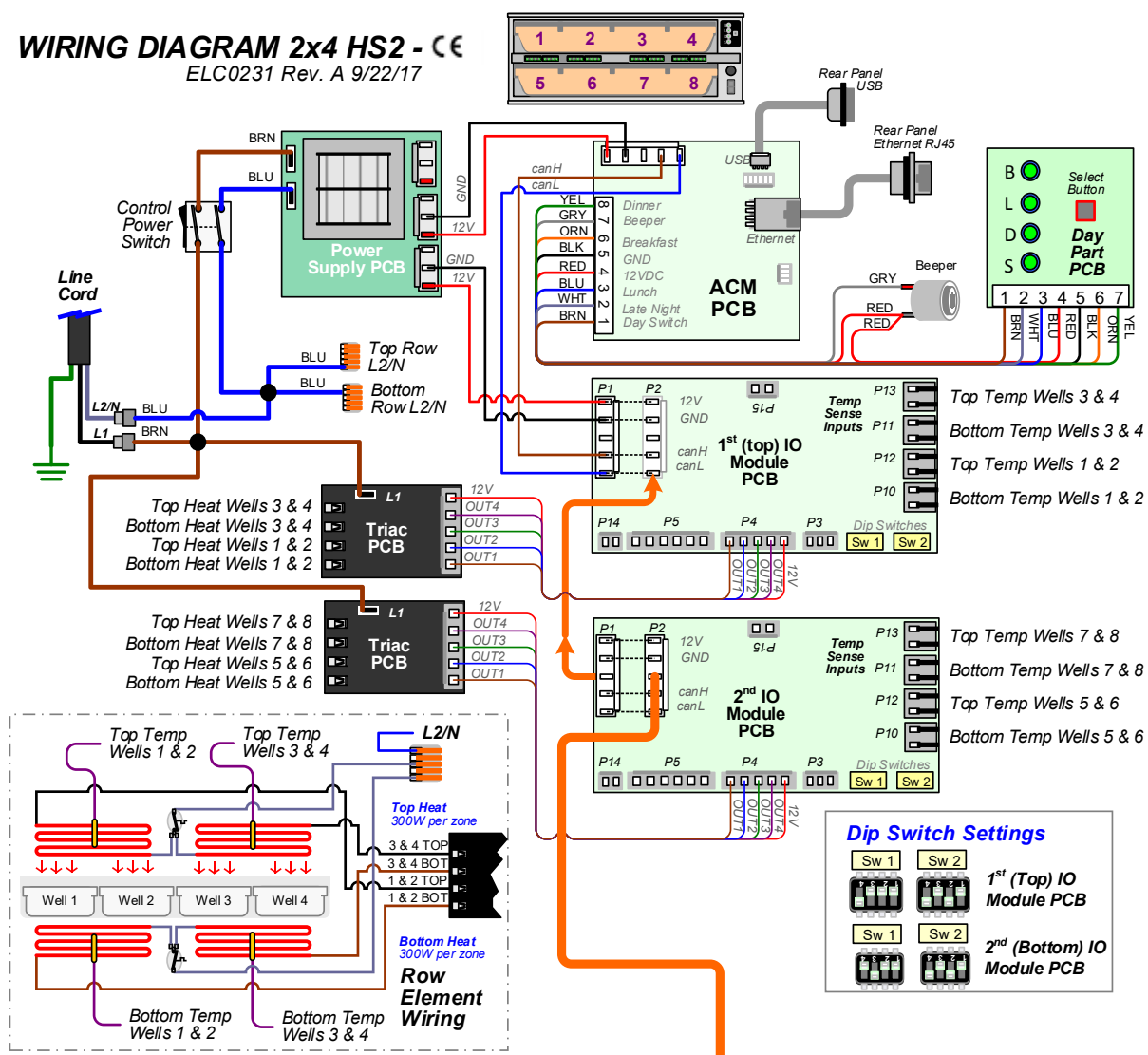

### Timer Bars

#### Front Timer Bars



#### Optional: Rear Timer Bars



# WIRE DIAGRAM

## HS2-34, 6-Zone CE Models

**WIRING DIAGRAM 3x4 HS2 - CE**  
ELC0232 Rev. A 9/22/17

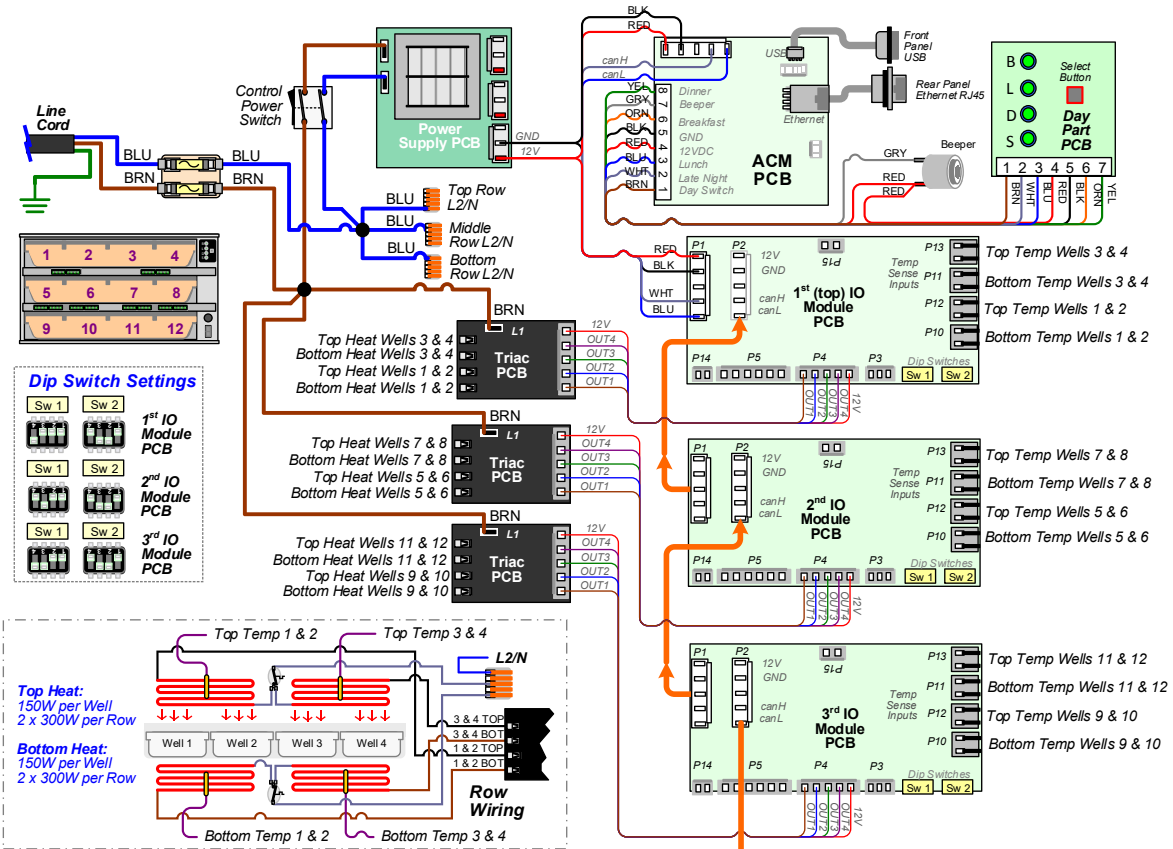

### Timer Bars

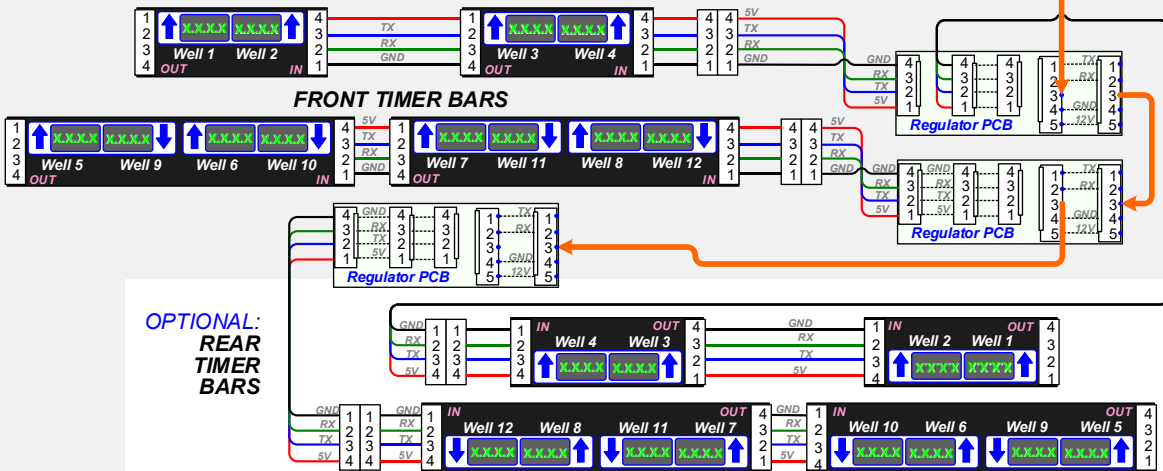

# WIRE DIAGRAM

## HS2-42, 4-Zone CE Models

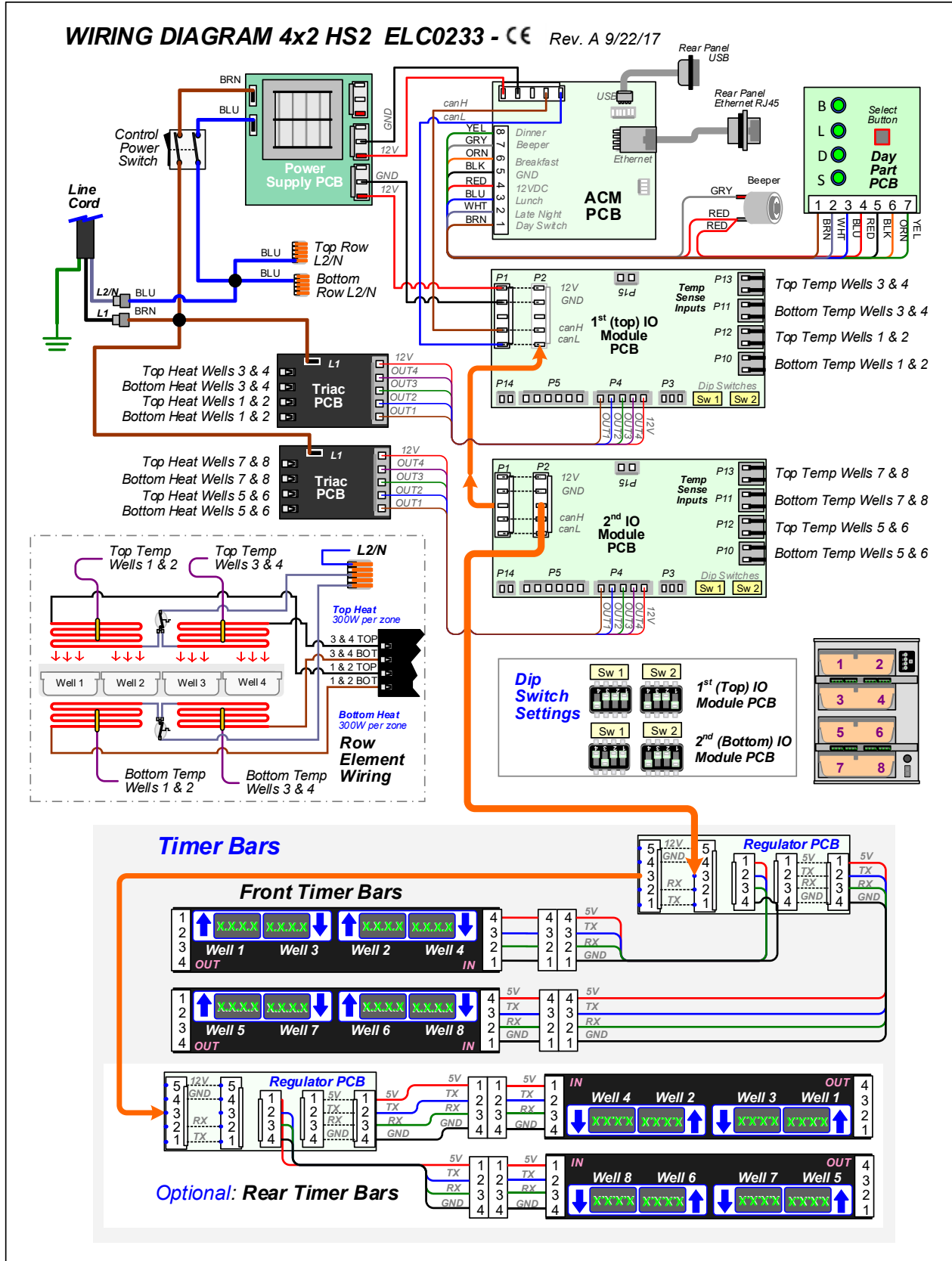



## NOTES



Your Solutions Partner

## **Duke Manufacturing Company**

**2305 N. Broadway  
St. Louis, MO 63102  
Phone: 314-231-1130  
Toll Free: 1-800-735-3853  
Fax: 314-231-5074  
[www.dukemfg.com](http://www.dukemfg.com)**