

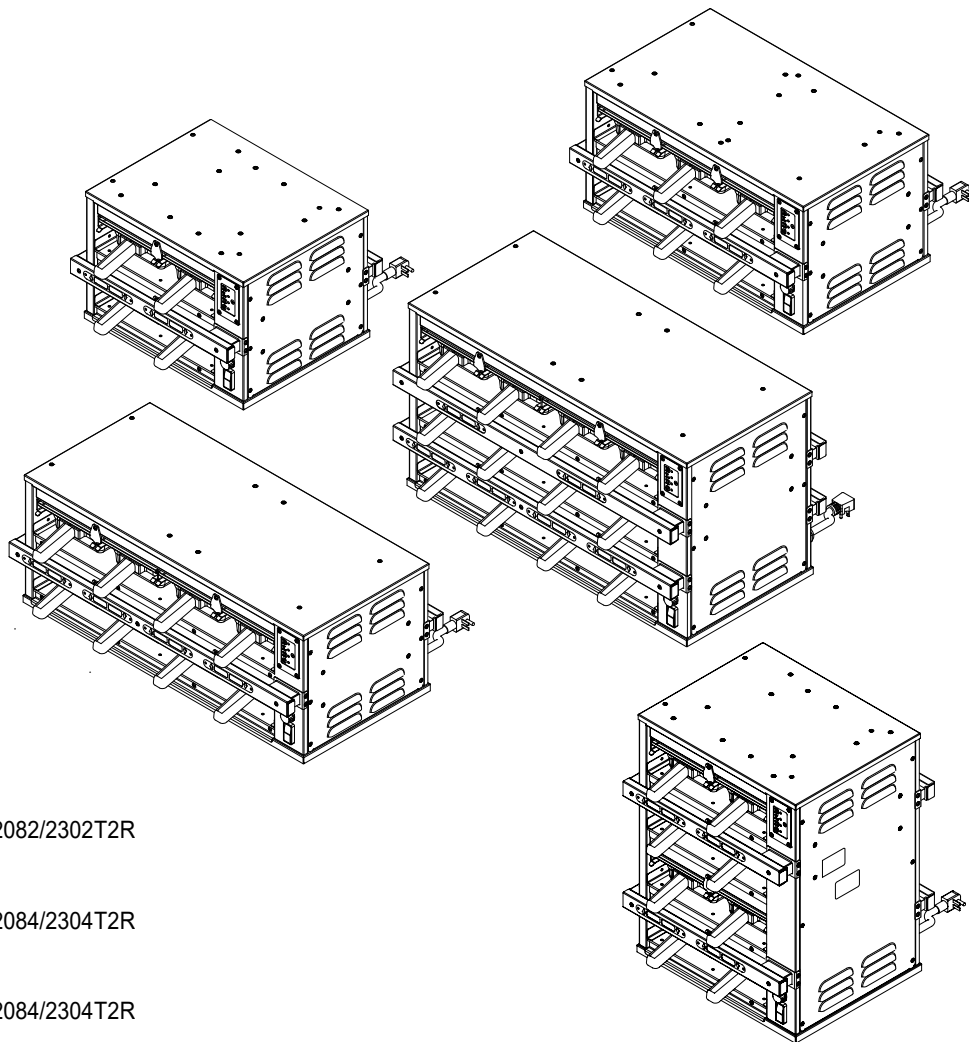

Your Solutions Partner

Illustrated Parts List

HS2 DUAL HEATSINK HOLDING UNITS



MODELS

HS2-22-2082/2302T1R	HS2-22-2082/2302T2R
HS2-23-1203/2303T1P	
HS2-23-2084/2304T1R	HS2-23-2084/2304T2R
HS2-24-1204/2304T1P	
HS2-24-2084/2304T1R	HS2-24-2084/2304T2R
HS2-34-2086/2306T1R	HS2-34-2086/2306T2R
HS2-42-2084/2304T1R	HS2-42-2084/2304T2R

*This manual is Copyright © 2020 Duke Manufacturing Co. All rights reserved.
Reproduction without written permission is prohibited. Duke is a registered
trademark of the Duke Manufacturing Co.*

Duke Manufacturing Co.

2305 N. Broadway • St. Louis, MO 63102
800.735.3853 • 314.231.1130
Fax: 314-231-5074
www.dukemfg.com

TABLE OF CONTENTS

HS2 MODEL NUMBER CONVENTION	3
TIMER BAR MODELS (HS2-22-2082/2302 T1R & T2R).....	4
Figure: PL-2 TIMER BAR MODELS (HS2-22-2082/2302 T1R & T2R)	4
Table: PL-2 TIMER BAR MODELS (HS2-22-2082/2302 T1R & T2R).....	5
TIMER BAR MODELS (HS2-23-1203/2084/2304 T1R, T1P & T2R).....	6
Figure: PL-4 TIMER BAR MODELS (HS2-23-1203/2084/2304 T1R, TP & T2R).....	6
Table: PL-4 TIMER BAR MODELS (HS2-23-1203/2084/2304 T1R, TP & T2R)	7
TIMER BAR MODELS (HS2-24-1204/2084/2304/2404 T1R & T2R).....	10
Figure: PL-6 TIMER BAR MODELS (HS2-24-1204/2084/2304 T1R, T1P & T2R).....	10
Table: PL-6 TIMER BAR MODELS (HS2-24-1204/2084/2304 T1R, T1P & T2R)	11
TIMER BAR MODELS (HS2-34-2086/2306/2406 T1R & T2R).....	14
Figure: PL-8 TIMER BAR MODELS (HS2-34-2086/2306 T1R & T2R)	14
Table: PL-8 TIMER BAR MODELS (HS2-34-2086/2306 T1R & T2R).....	15
TIMER BAR MODELS (HS2-42-2084/2304/2404 T1R & T2R).....	18
Figure: PL-10 TIMER BAR MODELS (HS2-42-2084/2304 T1R & T2R)	18
Table: PL-10 TIMER BAR MODELS (HS2-42-2084/2304 T1R & T2R).....	19
WIRING DIAGRAMS	21
HS2-22, 2-Zone Models	21
HS2-23, 2-Zone Models	22
HS2-23, 4-Zone Models	23
HS2-24, 4-Zone Models	24
HS2-34, 6-Zone Models	25
HS2-42, 4-Zone Models	26
HS2-22, 2-Zone CE Models	27
HS2-23, 4-Zone CE Models	28
HS2-24, 4-Zone CE Models	29
HS2-34, 6-Zone CE Models	30
HS2-42, 4-Zone CE Models	31
HS2-Zoned 23, 120V Models	32
HS2-24, 4Zone, 120V Models	33

HS2 MODEL NUMBER CONVENTION

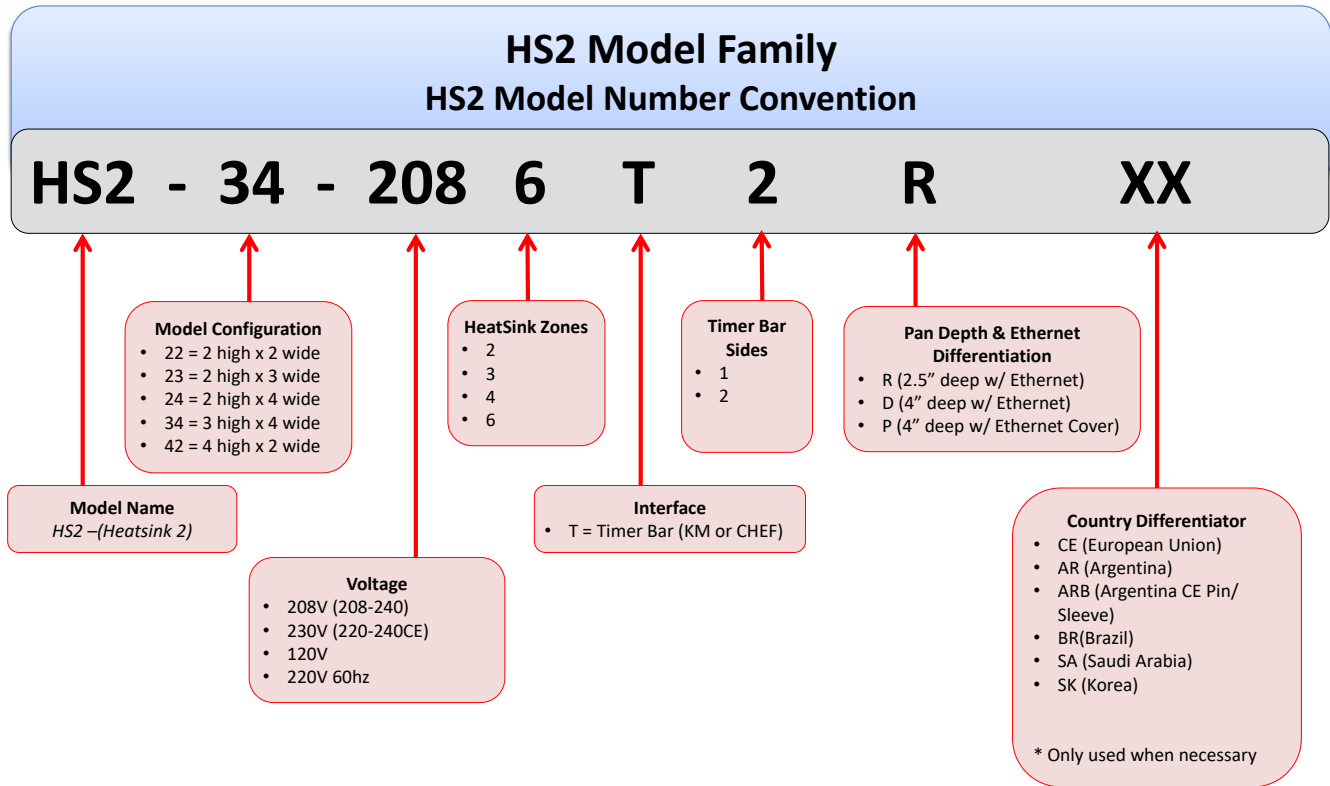

TIMER BAR MODELS HS2-22-2082/2302 T1R & T2R

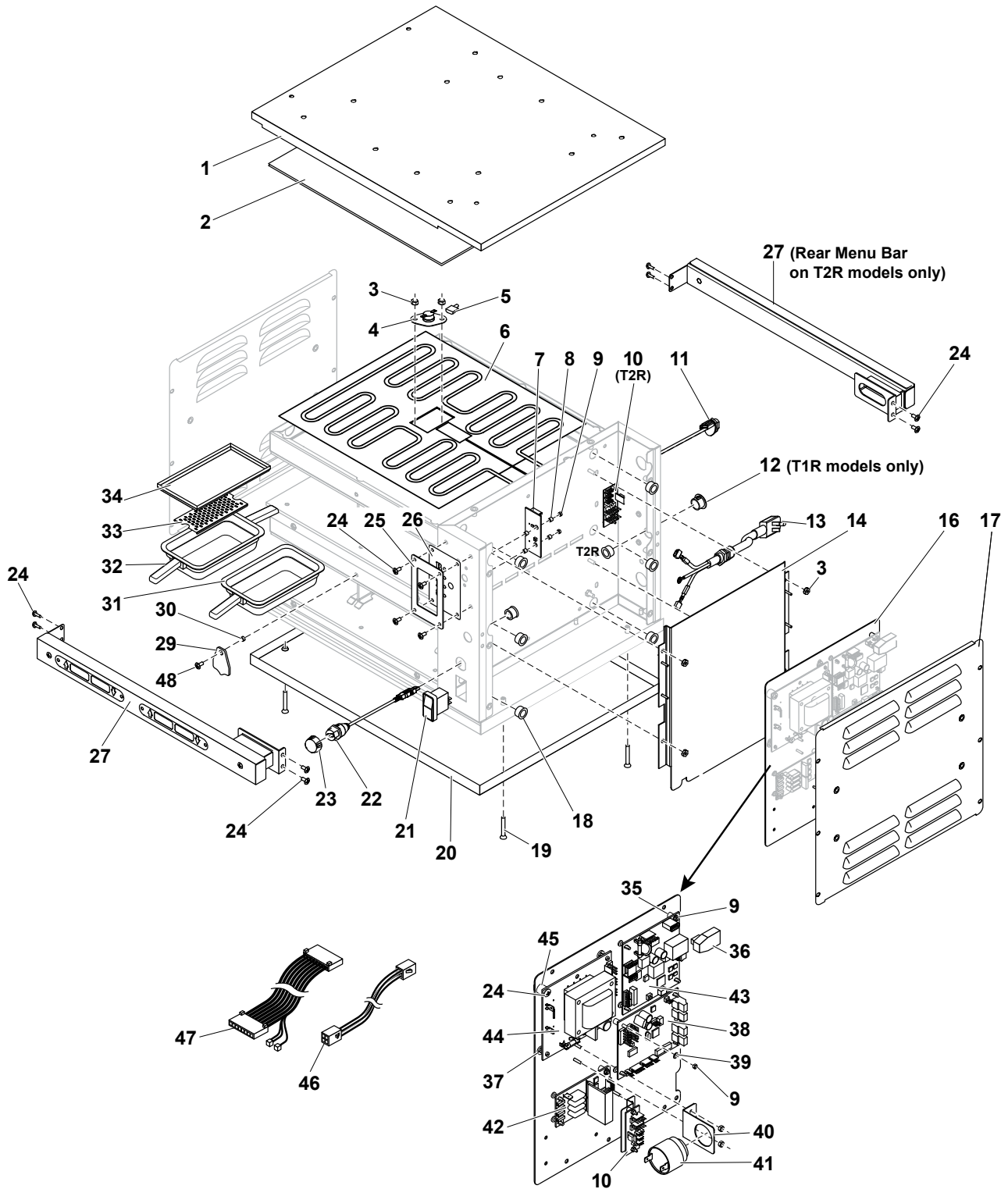

Figure: PL-1 TIMER BAR MODELS HS2-22-2082/2302 T1R & T2R

TIMER BAR MODELS HS2-22-2082/2302 T1R & T2R

ITEM	PART	DESCRIPTION	QUANTITY	
			T1R Models	T2R Models
1	1059-0521	HS2, TOP 2W RF		1
2	1059-0528	HS2, INSULATION 1/8" 2W		1
3	155680	NUT, KEPS 8-32 HEX ZP		42
4	158312	THERMOSTAT, HI-LIMIT 300 DEG W/FLANGE		4
5	222603	WIRE, JUMPER HS2 HEAT ELEMENT COM.		4
6	225225	HEATER, 2 WIDE 208/240V		4
Not Shown	158279	RTD, 1000 OHM-MEDIUM		A/R
7	225184	DUKE DAY PART PCB		1
8	225171	SPACER ROUND 1/4" X 1/8" IS DIA .115		4
9	223470	NUT, 4-40 NYLON LOCKNUT		7
10	225181	ASY, TIMER BAR 5V POWER PCB	1	2
11	118440	RJ45 Ethernet Cable, Panel Mount <i>(Replaced 118003 & 166111)</i>		1
	166111	MODULAR, JACK IP67 <i>(Replaced by 118003 -- 8/1/2017)</i>		1
12	1059-0723	HS2, MENU BAR HOLE PLUG	1	-
13	222170	POWER CORD, 15A 250V, W/TERMINALS, 6' LG <i>(208/240V Units)</i>		1
	160448	POWER CORD, 16A 230V, W/TERMINALS, 8' LG <i>(230V Units)</i>		1
14	1059-0729	HS2, CRTL MTG PLATE 2H PEMS <i>(Replaced 1059-0435)</i>		1
16	1059-0735	HS2, ASY, DMC CRTL MTG PLATE <i>(Replaced 1059-0537)</i>		1
17	1059-0446	ACCESS PANEL 2H <i>(208V Units = 2, 230V Units = 1)</i>		1 or 2
	1059-0571	ACCESS PANEL 2H CE <i>(Control Side of 230V Units = 1)</i>		1
18	225173	HEYCO, SNAP BUSHING OCB-625	7	8
19	10280050	SCREW, 8-32 x 1-1/4 FL PH SS MACHINE		4
20	1059-0456	HS2, BASE PAN 2W		1
21	169629	SWITCH, SEALED CARLING		1
22	ELC0084	USB-A TO PANEL MOUNT USB-A <i>(Replaced 225236)</i>		1
	225236	USB ADAPTER		1
23	1059-0679	HS2, COVER, USB <i>(Replaced 225237)</i>		1
	225237	USB COVER		1
24	279500	SCREW, 8-32 x 1/2" PTHMS 18-8SS		A/R
25	1059-0394	HS2, BEZEL DAYPART MYLAR		1
26	225165	MYLAR DAYPART		1
27	1059-0750K	HS2 MENU BAR 2W <i>(Side Mount)</i>	1	2
	1059-0474K	HS2 Menu Bar 2W <i>(Front Mount - Replaced by 1059-0750K - 3/7/2017)</i>	1	2
29	1059-0499	HS2, PAN STOP COVER		4
30	225238	HS2, Spacer Cover Stop		4
Not Shown	600532	Kit, Cover Stop w/10-32 Nutsert Tool <i>(Serial #s - 06170354 thru 08172054)</i>		1
Not Shown	600550	Kit, Lid Stop Screw Replacement <i>(Serial #s After - 08172054)</i>		1
31	156602	PAN, SINGLE HANDLE		A/R
32	156634	PAN, DOUBLE HANDLE		A/R
33	E030951	METAL TRIVET, 1/3 SIZE PAN		A/R
34	1059-0498	HS2 PAN COVER		A/R
35	166100	SPACER, TUBE NYLON 0.25 OD x 0.125 ID x 0.375 H		3
36	166184	USB. 2.0 MALE TO FEMALE RT. ANGLE ADAPTER		1
37	166101	SUPPORT, LOCK-IN PC		9
38	600517	KIT, SERVICE, PCB, IO3, HS2		1
39	166102	WASHER, 0.375 OD x 0.131D x 0.062THK		1
40	1059-0384	HS2, BUZZER MTG BRKT		1
41	512766	BUZZER, ULTRA LOUD CONTINUOUS TONE		1
42	166114	TRIAC PCB ASY		1
43	ELC0332	ACM BOARD, PROGRAMMED, HS2		1
44	600351	SERVICE KIT, 120011 POWER SUPPLY		1
45	120158	SPACER,NUT .375"		2
46	225219	JUMPER, 5V POWER IN-LINE SHORT		1
47	225216	DAY PART HARNESS		1
48	223467	Screw, 8-32 x 3/4"PTHMS 18-SS		A/R
Not Shown	225221	HARNESS IDC 12V & CAN		1
Not Shown	166105	JUMPER, HEAT TRIAC PCB		1
Not Shown	225234	HARNESS MAIN AC – HS2		1
Not Shown	166110	HARNESS, AC DMC 2X2		1
Not Shown	225220	HARNESS, TIMER BAR EXIT, DUAL <i>(T2R Models)</i>	-	1

Table: PL-1 TIMER BAR MODELS HS2-22-2082/2302 T1R & T2R

TIMER BAR MODELS HS2-23-1203/2084/2303/2304 T1R, T1P & T2R

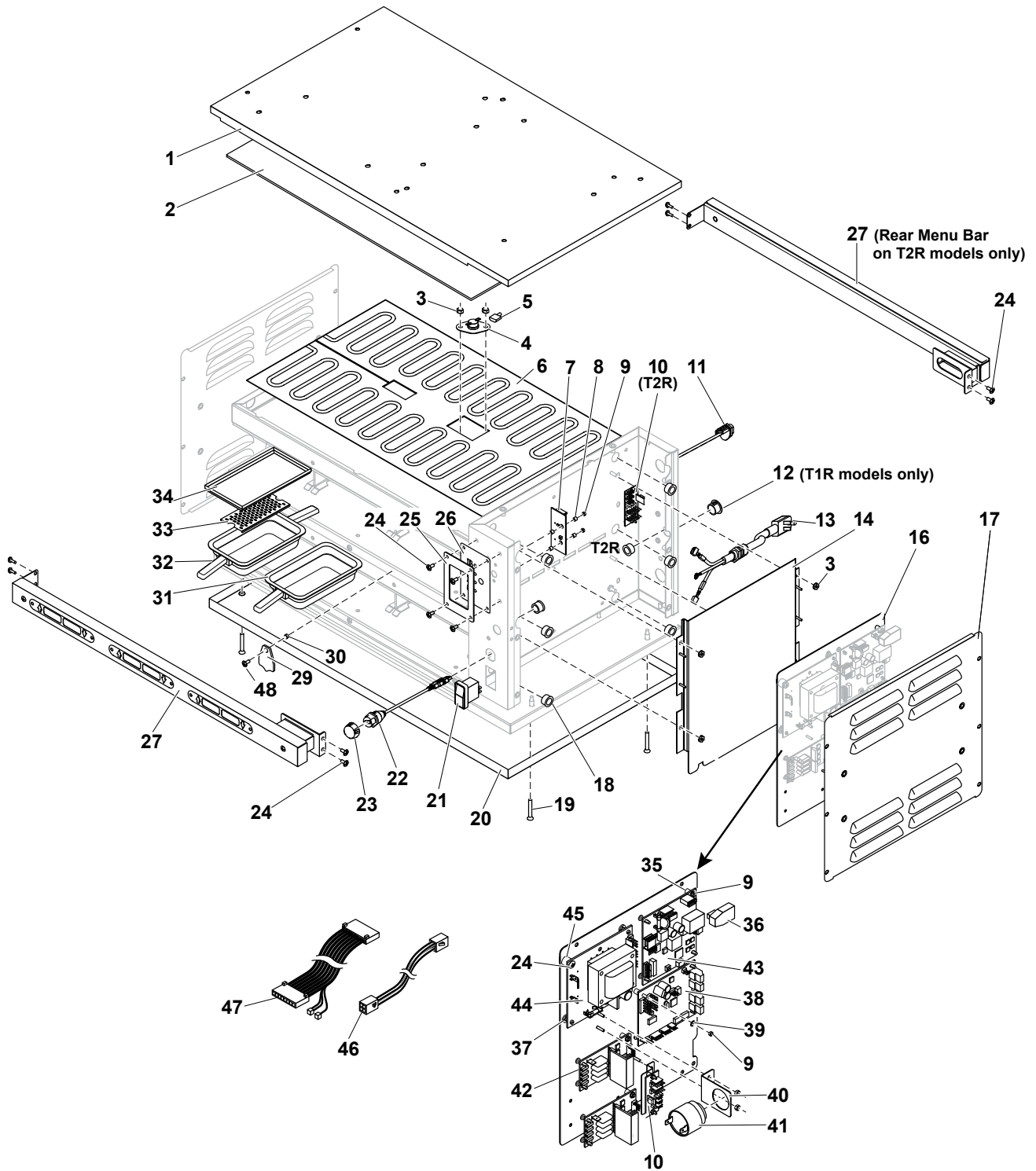

Figure: PL-2 TIMER BAR MODELS HS2-23-1203/2084/2303/2304 T1R, T1P & T2R

TIMER BAR MODELS HS2-23-1203/2084/2303/2304 T1R, T1P & T2R

ITEM	PART	DESCRIPTION	QUANTITY	
			T1R Models	T2R Models
1	1059-0519	HS2, TOP 3W RF	1	
2	1059-0255	INSULATION 1/8" 3W	1	
3	156680	NUT, KEPS 8-32 HEX ZP	50	
4	158312	THERMOSTAT, HI-LIMIT 300 DEG W/FLANGE	2	
Not Shown	512120	TERMINAL MULTIPLIER	2	
5	222603	WIRE, JUMPER HS2 HEAT ELEMENT COM.	2	
6	1059-0870	HEATER, 2 WIDE, 120V (3-Zone Units)	2	
	1059-0980	HEATER, 1 WIDE, 120V (3-Zone Units)	2	
	225174	HEATER, 2 WIDE, 208/240V (3 & 4-Zone Units - After 3/1/2017)	2	
	225257	HEATER, 1 WIDE, 208/240V (4-Zone Units - After 3/1/2017)	2	
	225223	HEATER, 3 WIDE, 208/240V (2-Zone Units - Before 3/1/2017)	4	
Not Shown	158279	RTD, 1000 OHM-MEDIUM	A/R	
7	225184	DUKE DAY PART PCB	1	
8	225171	SPACER ROUND 1/4" X 1/8" IS DIA .115	4	
9	223470	NUT, 4-40 NYLON LOCKNUT	A/R	
10	225181	ASY, TIMER BAR 5V POWER PCB	1	2
11	118440	RJ45 ETHERNET CABLE, PANEL MOUNT (Replaced 118003 & 166111)	1	
	166111	MODULAR, JACK IP67 (Replaced by 118003)	1	
Not Shown	1059-0937	HS2D ETHERNET PORT COVER	1	
12	1059-0723	HS2,MENU BAR HOLE PLUG (Alternate - 214487)	1	-
13	153743	POWER CORD, 15A 125V W/TERMINALS, 78" LG (120V Units)	1	
	222170	POWER CORD, 15A 250V, W/TERMINALS, 6' LG (208/240V Units)	1	
	160448	POWER CORD, 16A 230V, W/TERMINALS, 8' LG (230V Units)	1	
Not Shown	175515	STRAIN RELIEF, POWER CORD (Includes Nut)	1	
14	1059-0729	HS2, CRTL MTG PLATE 2H PEMS (Replaced 1059-0435)	1	
16	1059-0727	HS2, ASY, DMC CRTL MTG PLT 2x3, 208V/230V (Replaced 1059-0537)	1	
	1059-1007	HS2, CONTROL MTG PLATE 2x3 (4" Deep, 120V Units)	1	
17	1059-0446	ACCESS PANEL 2H (208V Units = 2, 230V Units = 1)	1 or 2	
	1059-0571	ACCESS PANEL 2H CE (Control Side of 230V Units)	1	
	1059-0867	ACCESS PANEL 2H (4" Deep Units, 120V = 2, 230V = 1)	1 or 2	
	1059-0994	ACCESS PANEL 2H (4" Deep Units, Control Side of 230V Units = 1)	1	
18	225173	HEYCO, SNAP BUSHING OCB-625	7	8
19	10280050	SCREW,8-32X1-1/4FL PH SS MACHINE	4	
20	1059-0452	HS2, BASE PAN 3W	1	
21	169629	SWITCH, SEALED CARLING	1	
22	ELC0084	USB-A TO PANEL MOUNT USB-A (Replaced 225236)	1	
	225236	USB ADAPTER	1	
23	1059-0679	HS2, COVER, USB (Replaced 225237)	1	
	225237	USB COVER	1	
Not Shown	1059-0731	THUMB SCREW, KNURLED HEAD (Use with 1059-0679 USB Cover)	1	
24	279500	SCREW, 8-32 x 1/2" PTHMS 18-8SS	A/R	
Not Shown	223467	SCREW, 8-32 X 3/4" TPF-M (Used with 1059-0871 & 1059-0499)	4	8
25	1059-0394	HS2, BEZEL DAYPART MYLAR	1	
26	225165	MYLAR DAYPART	1	
27	1059-0719K	HS2, MENU BAR, 3W (Side Mount)	1	2
	10590443K	HS2, MENU BAR, 3W (Front Mount-Replaced by 1059-0719K - 3/7/2017)	1	2
29	1059-0499	HS2, COVER STOP (Standard Cover Stop)	8	
Not Shown	1059-0871	HS2, COVER STOP SLIDE (Units with 1059-1032 Full Size Cover)	2	4
30	225238	HS2, SPACER COVER STOP (Used with 1059-0499 & 1059-0871)	4	8
Not Shown	1059-0930	HS2 4" DEEP, REAR PAN STOP (Requires (4) 223490 screws)	2	
Not Shown	223490	Screw, 8-32 x 3/4" PTHMS 18-8SS w/Nylon Patch (4" Deep Units)	14	
Not Shown	600532	Kit, Cover Stop w/10-32 Nutsert Tool (Serial #s - 06170354 thru 08172054)	1	
Not Shown	600550	Kit, Lid Stop Screw Replacement (Serial #s After - 08172054)	1	
31	156602	PAN, SINGLE HANDLE	1	
32	156634	PAN, DOUBLE HANDLE	1	
33	E030951	TRIVET, METAL, 1/3 SIZE PAN	6	
34	1059-0498	HS2 PAN COVER	A/R	

Table: PL-2 TIMER BAR MODELS HS2-23-1203/2084/2303/2304 T1R, T1P & T2R

TIMER BAR MODELS HS2-23-1203/2084/2303/2304 T1R, T1P & T2R (Continued)

ITEM	PART	DESCRIPTION	QUANTITY	
			T1R Models	T2R Models
Not Shown	1059-1032	HS2D PAN COVER, FULL SIZE PAN	A/R	
35	166100	SPACER, TUBE NYLON 0.25OD x 0.125ID x 0.375H	5	
36	166184	USB 2.0 MALE TO FEMALE RT. ANGLE ADAPTER	1	
37	166101	SUPPORT, LOCK-IN PC	1	
38	600517	KIT, SERVICE, PCB, IO3, HS2	2	
	ELC0001-7	PCB, 103, HS2	2	
39	166102	WASHER, 0.375OD x 0.13ID X 0.062THK	2	
40	1059-0384	HS2, BUZZER MTG BRKT	1	
41	512766	BUZZER, ULTRA LOUD CONTINUOUS TONE	1	
42	166114	TRIAC PCB ASY	2	
43	ELC0332	ACM Board, Programmed, HS2 (120/208/230V, 2-1/2" & 4" Deep Units)	1	
44	600352	KIT, SERVICE 225185 POWER SUPPLY (208/230V Units)	1	
	ELC0291	POWER SUPPLY-120VAC, 12VDC 3A (120V Units)	1	
45	120158	SPACER, NUT .375"	2	
46	225219	JUMPER, 5V POWER IN-LINE SHORT	1	2
47	225216	DAY PART HARNESS	1	
48	223467	Screw, 8-32 x 3/4" PTHMS 18-SS	A/R	
Not shown	225221	HARNESS IDC 12V & CAN	1	
Not shown	166105	JUMPER, HEAT TRIAC PCB	1	
Not shown	225234	HARNESS MAIN AC – HS2	1	
Not shown	166110	HARNESS, AC DMC 2X2	1	
Not Shown	212106	Connector, WAGO 5 Conductor	2	
Not Shown (4" Deep)	120102	FUSE HOLDER, MODULE CONTROL (120V, 4" Deep Units)	1	
	213032	SCREW, 8 X 1/2 TEK PHIL. (120V, 4" Deep Units)	2	
	120103	FUSE, 3AG, 12.5A (120V, 4" Deep Units)	1	
	ELC0369	HARNESS-MAIN AC FUSED (120V, 4" Deep Units)	1	

Table: PL-2 TIMER BAR MODELS HS2-23-1203/2084/2303/2304 T1R, T1P & T2R (Continued)

NOTES

TIMER BAR MODELS HS2-24-1204/2084/2304 T1R, T1P & T2R

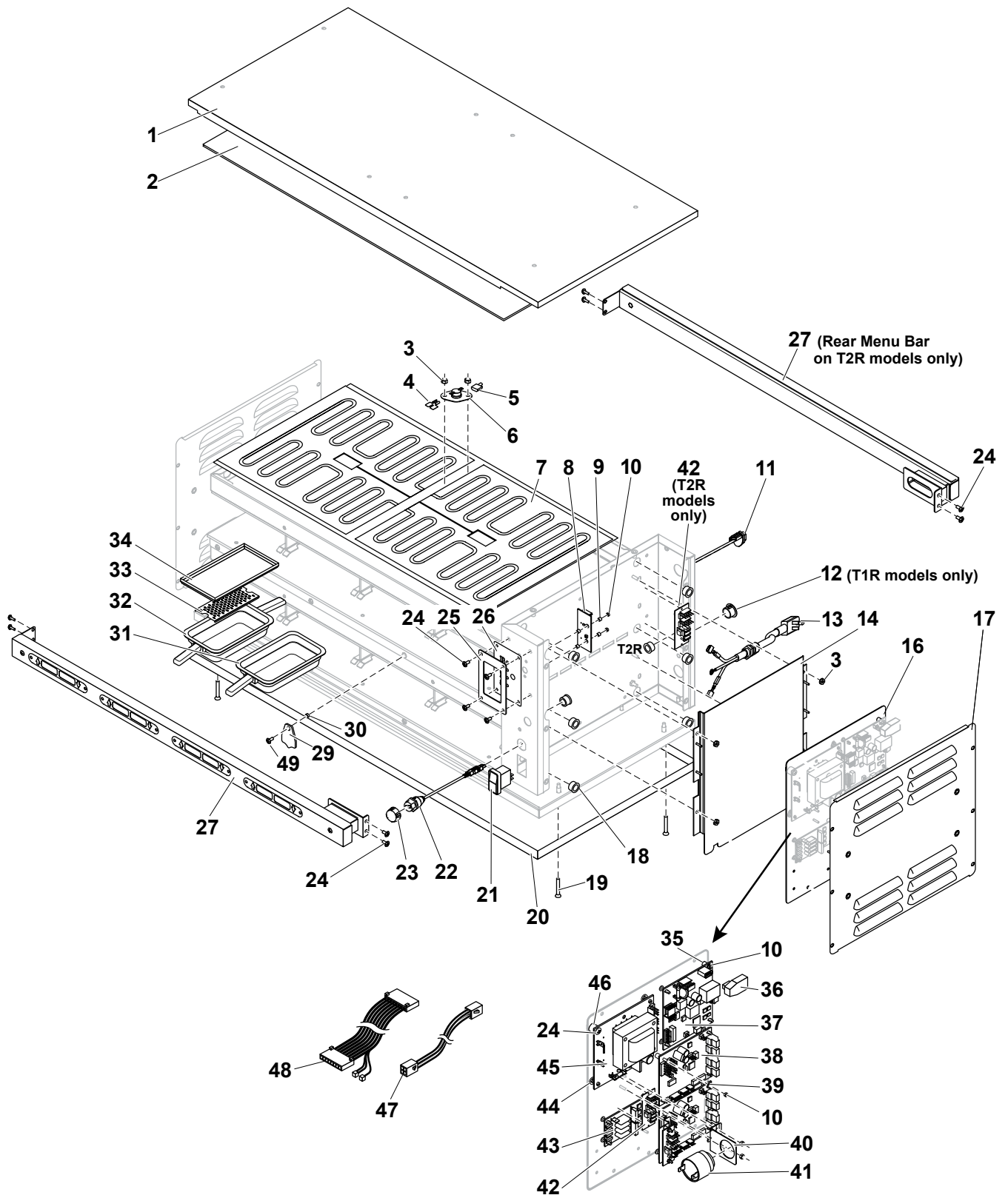

Figure: PL-3 TIMER BAR MODELS HS2-24-1204/2084/2304 T1R, T1P & T2R

TIMER BAR MODELS HS2-24-1204/2084/2304 T1R, T1P & T2R

ITEM	PART	DESCRIPTION	QUANTITY	
			T1R Models	T2R Models
1	1059-0827	HS2, TOP 4W RF (Replaced 1059-0502)		1
2	225180	INSULATION 1/8"		1
3	155680	NUT, KEPS 8-32 HEX ZP		58
4	512120	TERMINAL, MULTIPLIER - 34P2156		4
5	222603	WIRE, JUMPER HS2 HEAT ELEMENT COM.		4
6	158312	THERMOSTAT, HI-LIMIT 300 DEG W/FLANGE		4
7	1059-0870	HEATER, 2 WIDE, 120V		8
	225174	HEATER, 4 WIDE 208/240V		8
Not shown	158279	RTD, 1000 OHM-MEDIUM		A/R
8	225184	DUKE DAY PART PCB		1
9	225171	SPACER ROUND 1/4" X 1/8" IS DIA .115		4
10	223470	NUT, 4-40 NYLON LOCKNUT		A/R
11	118440	RJ45 Ethernet Cable, Panel Mount (Replaced 118003 & 166111)		1
	166111	MODULAR, JACK IP67 (Replaced by 118003 -- 8/1/2017)		1
Not Shown	1059-0937	HS2D EITHERNET PORT COVER		1
12	1059-0723	HS2, MENU BAR HOLE PLUG (Alternate - 214487)	1	-
13	153743	POWER CORD, 15A 125V W/TERMINALS, 78" LG (120V Units)		1
	222170	POWER CORD, 15A 250V, W/TERMINALS, 6' LG (208/240V Units)		1
	160448	POWER CORD, 16A 230V, W/TERMINALS, 8' LG (230V Units)		1
	522519	POWER CORD, KOREAN 16A 250V		1
Not Shown	175515	STRAIN RELIEF, POWER CORD (Use with 153743 Power Cord)		1
Not Shown	160486	STRAIN RELIEF, POWER CORD (Use with 654321 Power Cord)		1
14	1059-0729	HS2, ASY, CTRL VENT DUCT 2H (Replaced 1059-0435)		1
16	1059-0829	HS2, CRTL MTG PLATE 2x4 (208/230V Units, Replaced 1059-0537)		1
	1059-1006	HS2, CONTROL MTG PLATE 2x4 (4" Deep, 120V Units)		1
17	1059-0867	ACCESS PANEL 2H (4" Deep Units, 120V = 2, 230V = 1)		1 or 2
	1059-0994	ACCESS PANEL 2H (4" Deep Units, Control Side of 230V Units = 1)		1
	1059-0446	ACCESS PANEL 2H (208V Units = 2, 230V Units = 1)		1 or 2
	1059-0571	ACCESS PANEL 2H CE (Control Side of 230V Units -1)		1
18	225173	HEYCO, SNAP BUSHING OCB-625	7	8
19	10280050	SCREW, 8-32X1-1/4FL PH SS MACHINE		4
20	1059-0821	HS2, BASE PAN LEG MTG 4W (Replaced 1059-0339)		1
21	169629	SWITCH, SEALED CARLING		1
22	ELC0084	USB-A TO PANEL MOUNT USB-A		1
	225236	USB ADAPTER (Replaced by ELC0084)		1
23	1059-0679	HS2, COVER, USB		1
	225237	USB COVER (Replaced by 1059-0679)		1
Not Shown	1059-0731	THUMB SCREW, KNURLED HEAD (Use with 1059-0679 USB Cover)		1
24	279500	SCREW, 8-32 x 1/2" PTHMS 18-8SS		A/R
25	1059-0394	HS2, BEZEL DAYPART MYLAR		1
26	225165	MYLAR DAYPART		1
27	1059-0714K	HS2, MENU BAR 4W (Side Mount)	1	2
	1059-0210K	MENU BAR 4W (Front Mount-Replaced by 1059-0714K, 2/16/2017)	1	2
29	1059-0499	HS2, PAN STOP COVER		8
30	225238	HS2, Spacer Cover Stop		8
Not Shown	1059-0930	HS2 4" DEEP, REAR PAN STOP (Requires (4) 223490 screws)		2
Not Shown	223490	Screw, 8-32 x 3/4" PTHMS 18-8SS w/Nylon Patch (4" Deep Units)		8
Not Shown	600532	Kit, Cover Stop w/10-32 Nutsert Tool (Serial #s - 06170354 thru 08172054)		1
Not Shown	600550	Kit, Lid Stop Screw Replacement (Serial #s After - 08172054)		1
31	156602	PAN, SINGLE HANDLE		1
32	156634	PAN, DOUBLE HANDLE		1
33	E030951	TRIVET, METAL, 1/3 SIZE PAN		6
34	1059-0498	HS2 PAN COVER		1
35	166100	SPACER, TUBE NYLON 0.25OD x 0.125ID x 0.375H		5
36	166184	USB. 2.0 MALE TO FEMALE RT. ANGLE ADAPTER		1
37	ELC0332	ACM Board Programmed, HS2 (120/208/230V, 2-1/2 & 4" Deep Units)		1
38	600517	KIT, SERVICE, PCB, IO3, HS2		2
	ELC0001-7	PCB, IO3 (120V Units)		2

Table: PL-3 TIMER BAR MODELS HS2-24-1204/2084/2304 T1R, T1P & T2R

TIMER BAR MODELS HS2-24-1204/2084/2304 T1R, T1P & T2R (Continued)

ITEM	PART	DESCRIPTION	QUANTITY	
			T1R Models	T2R Models
39	166102	WASHER, 0.375OD x 0.131D x 0.062THK		2
40	1059-0384	HS2, BUZZER MTG BRKT		1
41	512766	BUZZER, ULTRA LOUD CONTINUOUS TONE		1
42	225181	ASY, TIMER BAR 5V POWER PCB	1	2
43	166114	TRIAC PCB ASY		2
44	166101	SUPPORT, LOCK-IN PC		15
45	600352	KIT, SERVICE 225185 POWER SUPPLY		1
	ELC0291	Power Supply-120VAC, 12VDC 3A (120V Units)		1
46	120158	SPACER, NUT .375"		2
47	225219	Harness, timer bar exit, quad		1
48	225216	Day part harness		1
49	223467	Screw, 8-32 x 3/4" PTHMS 18-SS		A/R
Not Shown	225221	HARNESS IDC 12V & CAN		1
Not Shown	166105	JUMPER, HEAT TRIAC PCB		1
Not Shown	225234	HARNESS MAIN AC – HS2		1
Not Shown	166110	HARNESS, AC DMC 2X2		1
Not Shown	212106	Connector, WAGO 5 Conductor		1
Not Shown (4" Deep)	120102	Fuse Holder, Module Control (120V, 4" Deep Units)		1
	213032	Screw, 8x 1/2 TEK Phil. (120V, 4" Deep Units)		2
	120103	Fuse, 3AG, 12.5A (120V, 4" Deep Units)		1
	ELC0369	HARNESS-MAIN AC FUSED (120V, 4" Deep Units)		1

Table: PL-3 TIMER BAR MODELS HS2-24-2084/2304 T1R, T1P & T2R (Continued)

NOTES

Illustrated Parts Lists – HS2 Dual Heatsink Holding Units
TIMER BAR MODELS HS2-34-2086/2306 T1R & T2R

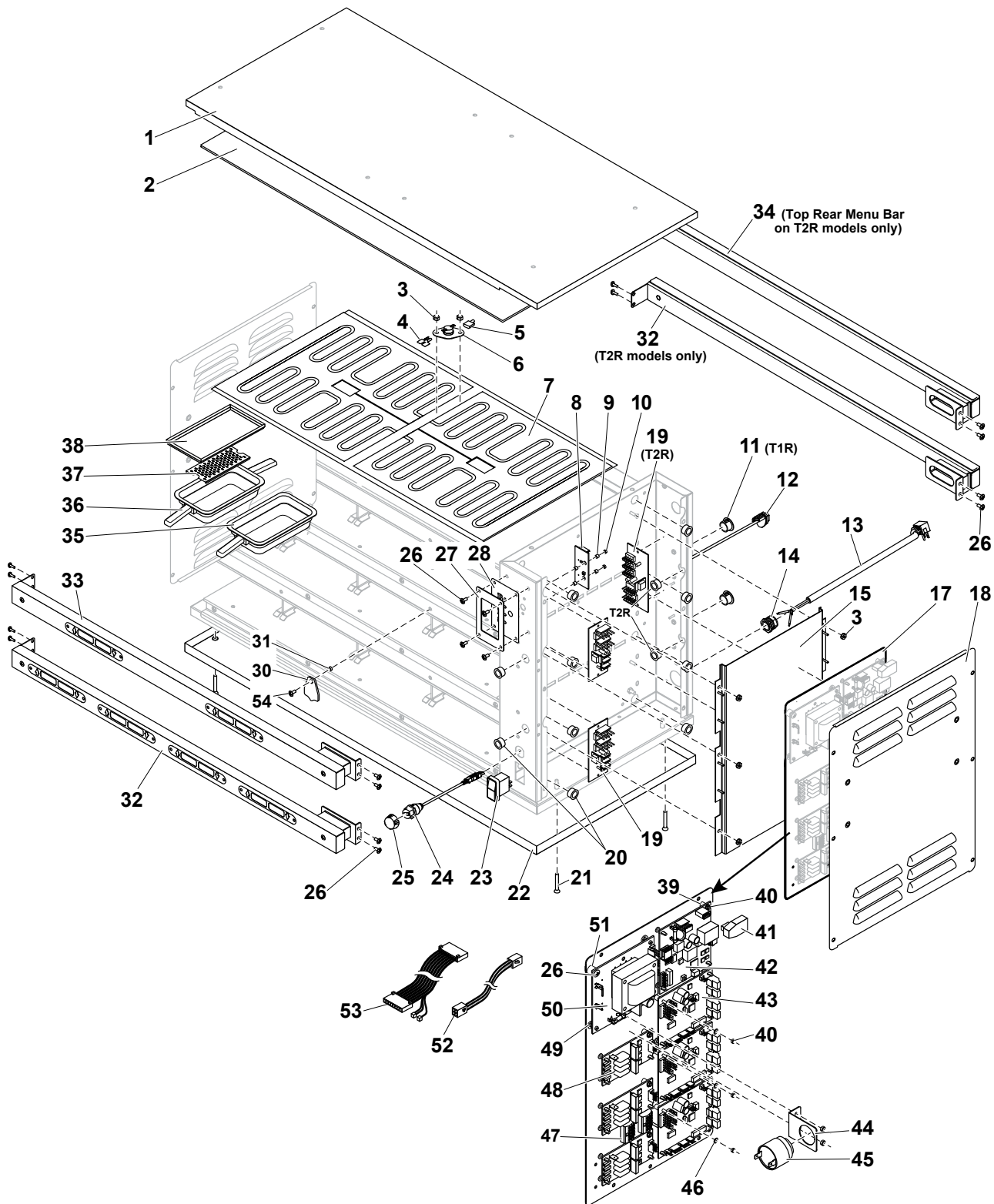

Figure: PL-4 TIMER BAR MODELS HS2-34-2086/2306 T1R & T2R

TIMER BAR MODELS HS2-34-2086/2306 T1R & T2R

ITEM	PART	DESCRIPTION	QUANTITY	
			T1R Models	T2R Models
1	1059-0827	HS2, TOP 4W <i>(Replaced 1059-0502)</i>	1	
2	225180	INSULATION 1/8"	1	
3	155680	NUT, KEPS 8-32 HEX ZP	68	
4	512120	TERMINAL, MULTIPLIER - 34P2156	6	
5	222603	WIRE, JUMPER HS2 HEAT ELEMENT COM.	6	
6	158312	THERMOSTAT, HI-LIMIT 300 DEG W/FLANGE	6	
7	225174	HEATER, 4 WIDE 208/240V	12	
Not Shown	158279	RTD, 1000 OHM-MEDIUM	A/R	
8	225184	DUKE DAY PART PCB	1	
9	225171	SPACER ROUND 1/4" x 1/8" IS DIA .115	4	
10	223470	NUT, 4-40 NYLON LOCKNUT	4	
11	1059-0723	HS2, MENU BAR HOLE PLUG	2	-
12	118440	RJ45 Ethernet Cable, Panel Mount <i>(Replaced 118003 & 166111)</i>	1	
	166111	MODULAR, JACK IP67 <i>(Replaced by 118003 -- 8/1/2017)</i>	1	
13	166070	POWER CORD, 20 AMP 208/240, W/TERMIANLS, 6-1/2' LG	1	
	160448	POWER CORD, 16A 230V, W/TERMINALS, 8' LG <i>(230V Units)</i>	1	
	522519	POWER CORD, KOREAN 16A 250V	1	
14	160486	STRAIN RELIEF, CORD <i>(Use with 166070 & 654321 Power Cords)</i>	1	
15	1059-0781	HS2, CRTL MTG PLATE 3H PEMS <i>(Replaced 1059-0420)</i>	1	
17	1059-0782	HS2, ASY, DMC CRTL MTG PLATE <i>(Replaced 1059-0536)</i>	1	
18	1059-0385	HS2, ASY ACCESS PANEL 3H <i>(208V Units = 2, 230V Units = 1)</i>	1 or 2	
	1059-0546	ACCESS PANEL 3H CE <i>(Control Side of 230V Units = 1)</i>	1	
19	225181	ASY, TIMER BAR 5V POWER PCB	2	3
20	225173	HEYCO, SNAP BUSHING OCB-625	10	12
21	10280050	SCREW, 8-32 x 1-1/4 FL PH SS MACHINE	4	
22	1059-0821	HS2, BASE PAN LEG MTG 4W <i>(Replaced 1059-0339)</i>	1	
23	169629	SWITCH, SEALED CARLING	1	
24	ELC0084	USB-A TO PANEL MOUNT USB-A	1	
	225236	USB ADAPTER <i>(Replaced by ELC0084)</i>	1	
25	1059-0679	HS2, COVER, USB	1	
	225237	USB COVER <i>(Replaced by 1059-0679)</i>	1	
26	279500	SCREW, 8-32 x 1/2" PTHMS 18-8SS	A/R	
Not Shown	1059-0731	THUMB SCREW, KNURLED, 8-32 x 5/8" Long, SS	1	
Not Shown	1059-0732	NUT, FLEX LOCK 18-8 SS, 8-32	1	
27	1059-0394	HS2, BEZEL DAYPART MYLAR	1	
28	225165	MYLAR DAYPART	1	
30	1059-0499	HS2, PAN STOP COVER	12	
31	225238	HS2, SPACER COVER STOP	12	
Not Shown	600532	Kit, Cover Stop w/10-32 Nutsert Tool <i>(Serial #s - 06170354 thru 08172054)</i>	1	
Not Shown	600550	Kit, Lid Stop Screw Replacement <i>(Serial #s After - 08172054)</i>	1	
32	1059-0714K	HS2, MENU BAR 4W <i>(Side Mount)</i>	1	2
	1059-0210K	HS2 MENU BAR 4W <i>(Front Mount-Replaced by 1059-0714K, 2/16/17)</i>	1	2
33	1059-0713K	HS2, TOP MENU BAR 4W <i>(Side Mount)</i>	1	1
	1059-0209	HS2, TOP MENU BAR 4W <i>(Front Mount-Replaced by 1059-0713K, 2/16/17)</i>	1	1
34	1059-0726K	HS2, TOP REAR MENU BAR 4W <i>(Side Mount)</i>	-	1
	1059-0475K	HS2, Top Rear Menu Bar 4W <i>(Front Mount-Replaced by 1059-0726K, 2/16/17)</i>	-	1
35	156602	PAN, SINGLE HANDLE	A/R	
36	156634	PAN, DOUBLE HANDLE	A/R	
37	E030951	TRIVET, METAL, 1/3 SIZE PAN	A/R	
38	1059-0498	HS2, PAN COVER	8	
39	166100	SPACER, TUBE NYLON 0.25OD X 0.125ID X 0.375H	7	
40	223470	NUT, 4-40 NYLON LOCKNUT	7	
41	166184	USB. 2.0 MALE TO FEMALE RIGHT ANGLE ADAPTER	1	
42	ELC0332	ACM BOARD, PROGRAMMED, HS2	1	
43	600517	KIT, SERVICE, PCB, IO3, HS2	3	
44	1059-0384	HS2, BUZZER MTG BRKT	1	
45	512766	BUZZER, ULTRA LOUD CONTINUOUS TONE	1	
46	166102	WASHER, 0.375 OD x 0.13ID x 0.062 THK	1	
47	212106	CONNECTOR WAGO 5 CONDUCTOR 222-415	2	
48	166114	TRIAC PCB ASY	3	
49	166101	SUPPORT, LOCK-IN PC	21	

Table: PL-4 TIMER BAR MODELS HS2-34-2086/2306 T1R & T2R

TIMER BAR MODELS HS2-34-2086/2306 T1R & T2R (Continued)

ITEM	PART	DESCRIPTION	QUANTITY	
			T1R Models	T2R Models
50	600352	KIT, SERVICE 225185 POWER SUPPLY	1	
51	120158	SPACER,NUT .375"	2	
52	225219	JUMPER, POWER IN-LINE SHORT	2	3
	225220	JUMPER, POWER IN-LINE LONG	-	1
53	225216	DAY PART HARNESS	1	
54	223467	SCREW, 8-32 x 3/4"PTHMS 18-SS	A/R	
Not Shown	ELC0135	HARNESS MAIN AC COMMON 3X4 HS2	1	
Not Shown	225221	HARNESS IDC 12V & CAN	1	
Not Shown	166105	JUMPER,HEAT TRIAC PCB	3	
Not Shown	166109	HARNESS, AC DMC 2X4	1	
Not Shown	166104	JUMPER,IO TO IO	-	1
Not Shown	600553	JUMPER - FUSE DELETE, 3x4 HS2	1	
Not Shown	120102	FUSE HOLDER, MODULE CONTROL <i>(Canadian Units Only)</i>	1	
	213032	SCREW, 8 x 1/2 PPFS <i>(Canadian Units Only)</i>	2	
	166030	FUSE, 500V 3AB FAST 16 AMP <i>(Canadian Units Only)</i>	2	
Not Shown	216578	SEALANT, 108 RTV, GRAY 10 OZ.	1	

NOTES

TIMER BAR MODELS HS2-42-2084/2304 T1R & T2R

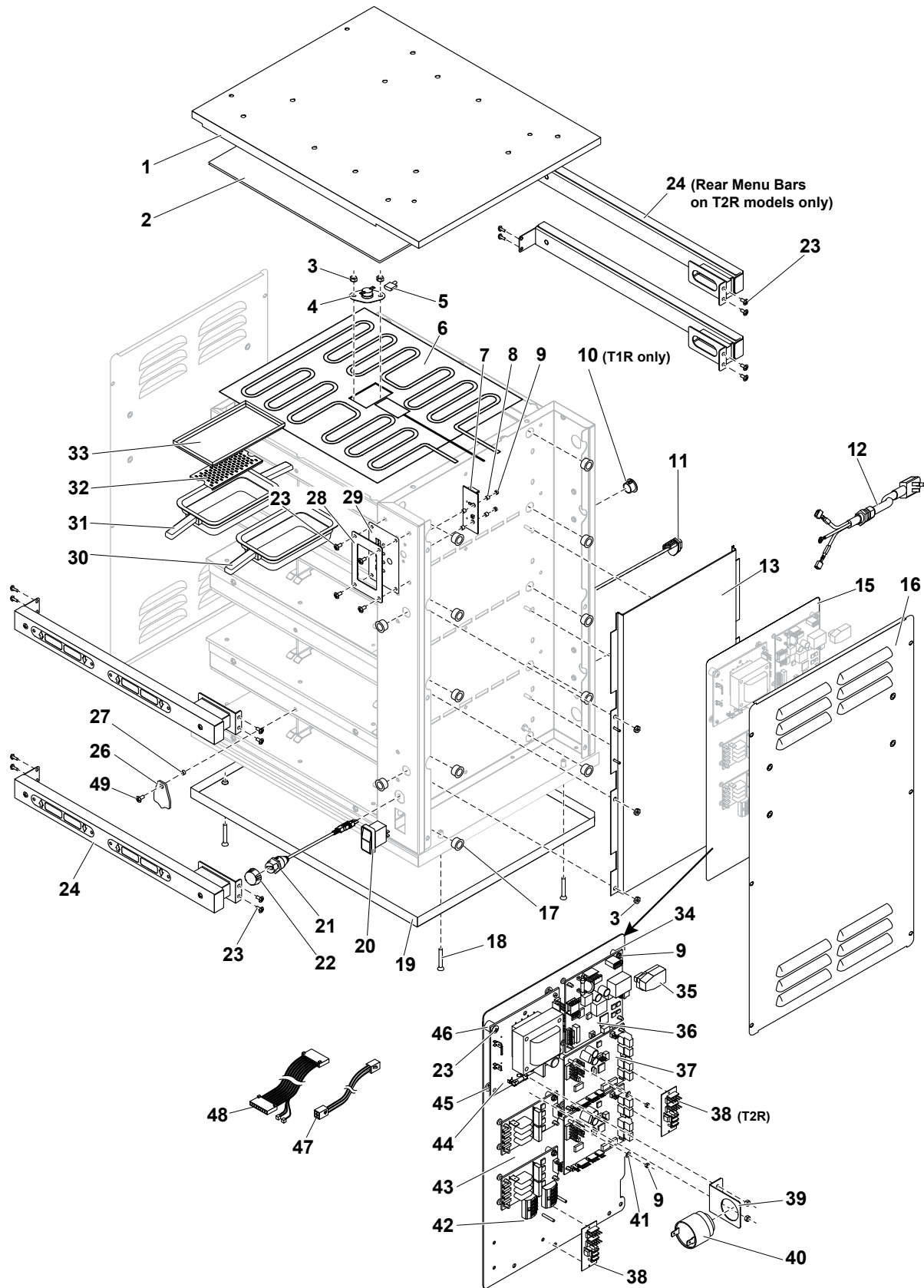

Figure: PL-5 TIMER BAR MODELS HS2-42-2084/2304 T1R & T2R)

TIMER BAR MODELS HS2-42-2084/2304 T1R & T2R

ITEM	PART	DESCRIPTION	QUANTITY	
			T1R Models	T2R Models
1	1059-0521	HS2, TOP 2W RF		1
2	1059-0528	HS2, INSULATION 1/8" 2W		1
3	155680	NUT, KEPS 8-32 HEX ZP		60
4	158312	THERMOSTAT, HI-LIMIT 300 DEG W/FLANGE		8
5	222603	WIRE, JUMPER HS2 HEAT ELEMENT COM.		8
6	225225	HEATER, 2 WIDE 208/240V		8
Not Shown	158279	RTD, 1000 OHM-MEDIUM		A/R
7	225184	DUKE DAY PART PCB		1
8	225171	SPACER ROUND 1/4" X 1/8" IS DIA .115		12
9	223470	NUT, 4-40 NYLON LOCKNUT		9
10	1059-0723	HS2, MENU BAR HOLE PLUG	2	-
11	118440	RJ45 Ethernet Cable, Panel Mount <i>(Replaced 118003 & 166111)</i>		1
	166111	MODULAR, JACK IP67 <i>(Replaced by 118003 -- 8/1/2017)</i>		1
12	222170	POWER CORD, 15 AMP 208/240V		1
	160448	POWER CORD, 16 AMP 230V IEC60309		1
	522519	POWER CORD, KOREAN 16A 250V		1
Not Shown	160486	STRAIN RELIEF, CORD <i>(Use with 654321 Power Cords)</i>		1
13	1059-0781	CONTROL MOUNTING PANEL ASSY <i>(Replaced 1059-0531)</i>		1
15	1059-0751	CONTROL MOUNTING PLATE ASSY <i>(Replaced 1059-0536)</i>		1
16	1059-0495	ACCESS PANEL 4H <i>(208V Units = 2, 230V Units = 1)</i>		1 or 2
	1059-0574	ACCESS PANEL 4H CE <i>(Control Side of 230V Units = 1)</i>		1
17	225173	HEYCO, SNAP BUSHING OCB-625	12	14
18	10280050	SCREW, 8-32X1-1/4FL PH SS MACHINE		4
19	1059-0456	HS2, BASE PAN 2W		1
20	169629	SWITCH, SEALED CARLING		1
21	ELC0084	USB-A TO PANEL MOUNT USB-A		1
	225236	USB ADAPTER <i>(Replaced by ELC0084)</i>		1
22	1059-0679	HS2, COVER, USB		1
	225237	USB COVER <i>(Replaced by 1059-0679)</i>		1
23	279500	SCREW, 8-32 x 1/2" PTHMS 18-8SS		A/R
24	1059-0750K	MENU BAR 2W <i>(Side Mount)</i>	2	4
	1059-0474K	MENU BAR 2W <i>(Front Mount-Replaced by 1059-0750K - 3/7/2017)</i>	2	4
26	1059-0499	HS2, PAN STOP COVER		8
27	225238	HS2, SPACER COVER STOP		8
Not Shown	600532	Kit, Cover Stop w/10-32 Nutsert Tool <i>(Serial #s - 06170354 thru 08172054)</i>		1
Not Shown	600550	Kit, Lid Stop Screw Replacement <i>(Serial #s After - 08172054)</i>		1
28	1059-0394	HS2, BEZEL DAYPART MYLAR		1
29	225165	MYLAR DAYPART		1
30	156602	PAN, SINGLE HANDLE		1
31	156634	PAN, DOUBLE HANDLE		1
32	E030951	TRIVET, METAL, 1/3 SIZE PAN		2
33	1059-0498	HS2, PAN COVER		6
34	166100	SPACER, TUBE NYLON 0.25OD X 0.125ID X 0.375H		1
35	166184	USB. 2.0 MALE TO FEMALE RT. ANGLE ADAPTER		1
36	ELC0332	ACM BOARD, PROGRAMMED, HS2		1
37	600517	KIT, SERVICE, PCB, IO3, HS2		2
38	225181	ASY, TIMER BAR 5V POWER PCB	1	2
39	1059-0384	HS2, BUZZER MTG BRKT		1
40	512766	BUZZER, ULTRA LOUD CONTINUOUS TONE		1
41	166102	WASHER, 0.375OD X 0.13ID X 0.062THK		2
42	212106	CONNECTOR WAGO 5 CONDUCTOR 222-415		2
43	166114	TRIAC PCB ASY		2
44	600352	KIT, SERVICE 225185 POWER SUPPLY		1
45	166101	SUPPORT, LOCK-IN PC		15
46	120158	SPACER, NUT .375"		2
47	225219	JUMPER, 5V POWER IN-LINE SHORT	2	4
48	225216	DAY PART HARNESS		1
49	223467	Screw, 8-32 x 3/4" PTHMS 18-SS		A/R

Table: PL-5 TIMER BAR MODELS HS2-42-2084/2304 T1R & T2R

TIMER BAR MODELS HS2-42-2084/2304 T1R & T2R (Continued)

ITEM	PART	DESCRIPTION	QUANTITY	
			T1R Models	T2R Models
Not Shown	225221	HARNES IDC 12V & CAN	1	
Not Shown	166105	JUMPER,HEAT TRIAC PCB	2	
Not Shown	225234	HARNES MAIN AC – HS2	1	
Not Shown	225255	HS2 AC 4X2	1	

WIRING DIAGRAMS

HS2-22, 2-Zone Models

WIRING DIAGRAM 2x2 HS2

225247 Rev. C 6/1/17

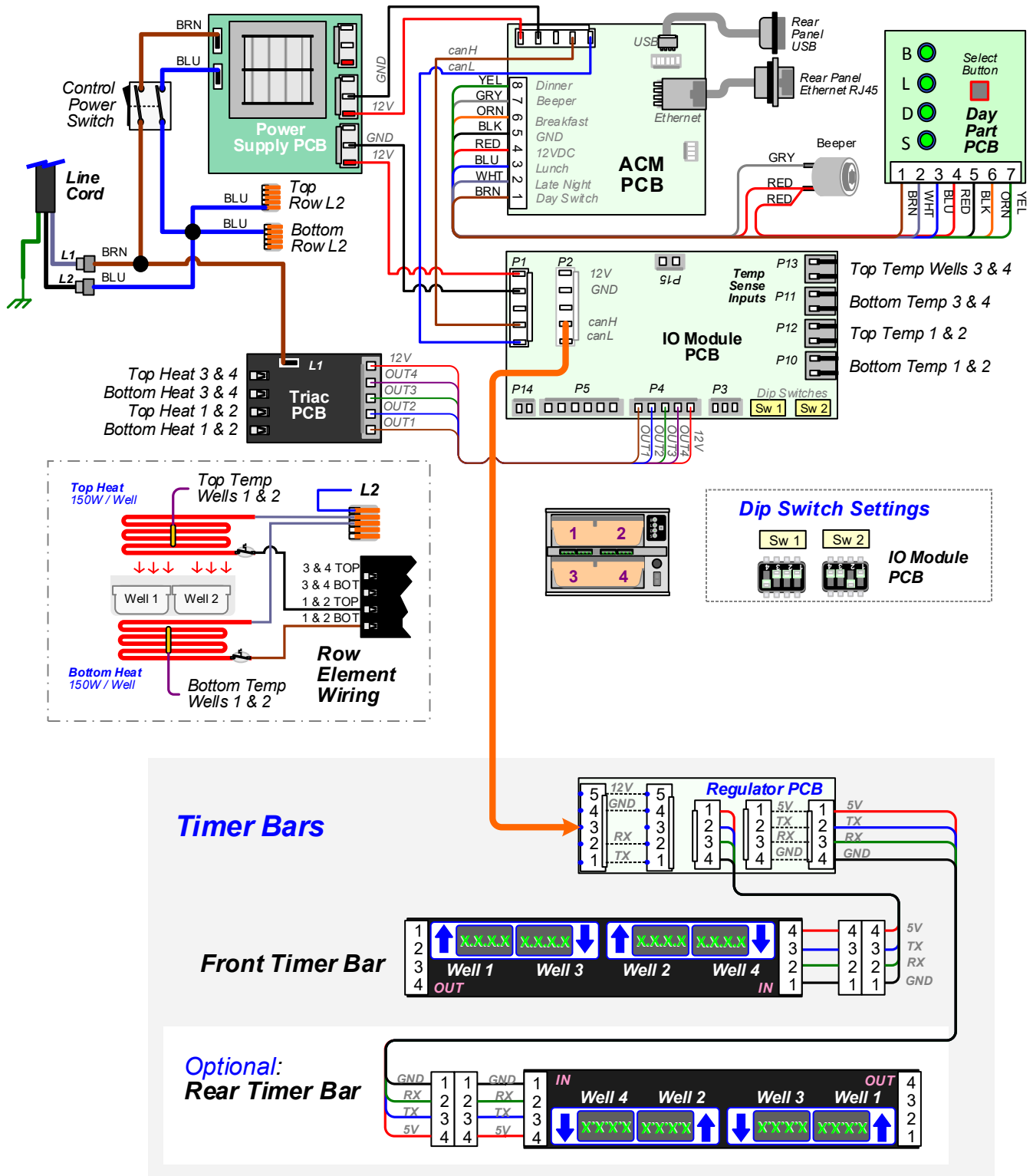

WIRING DIAGRAMS

HS2-23, 2-Zone Models

WIRING DIAGRAM 2x3 HS2

225246 Rev. B 6/1/17

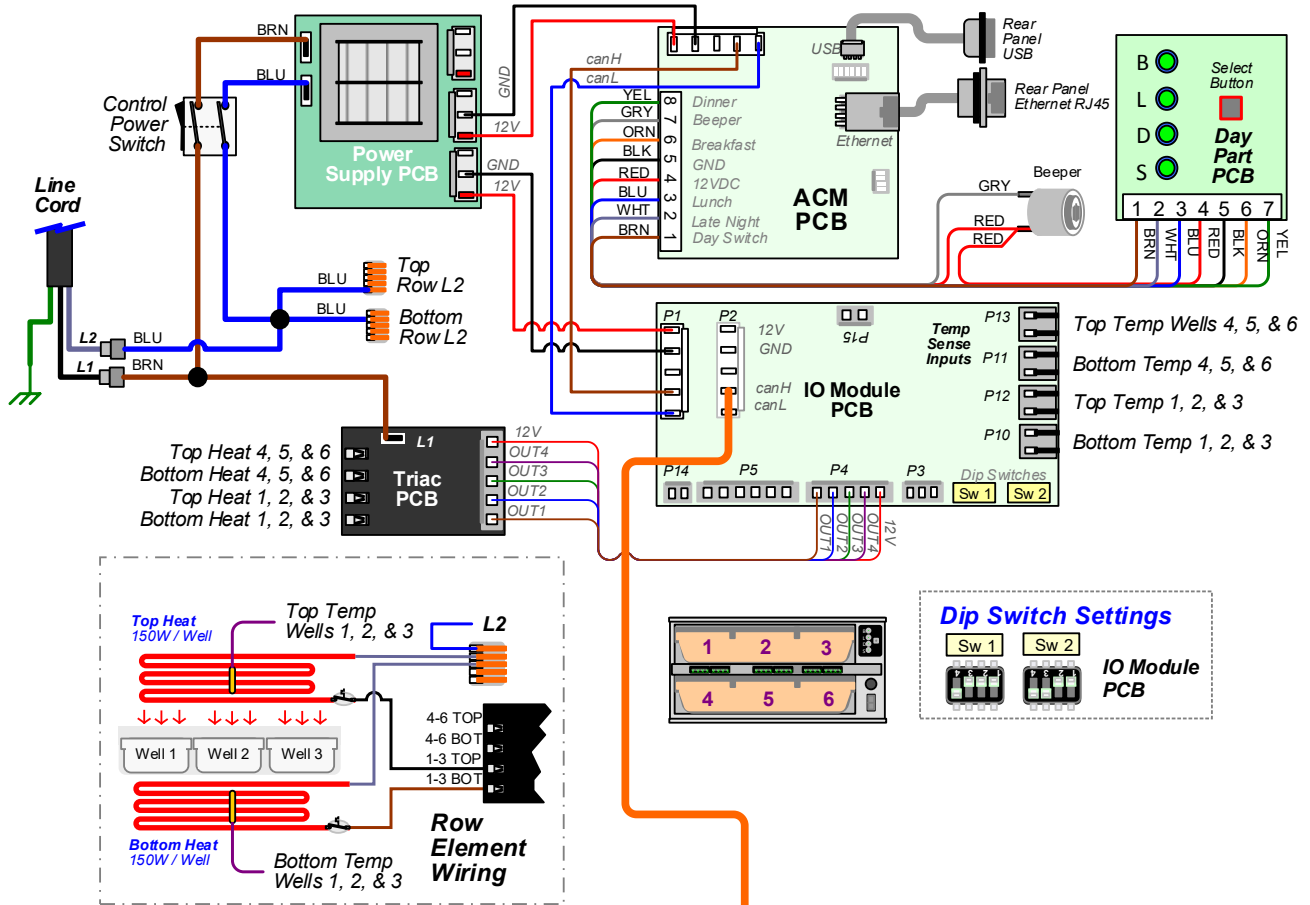

Timer Bar Models

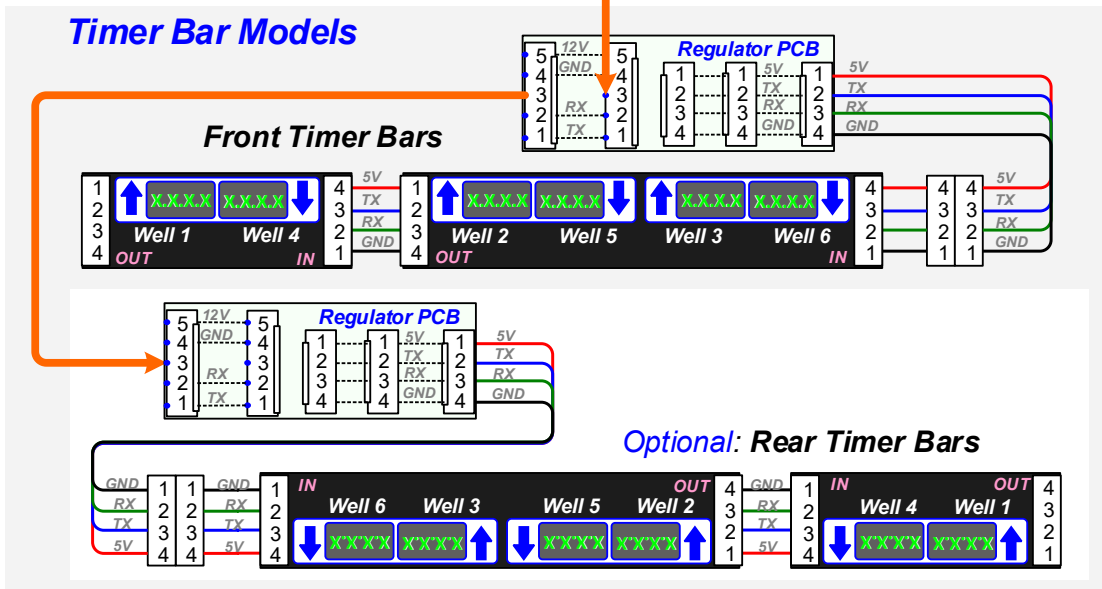

WIRE DIAGRAM

HS2-23, 4-Zone Models

Wire Diagram - HS2 Zoned 2 x 3

ELC0131 Rev. B (2x3_4z) 6/1/17

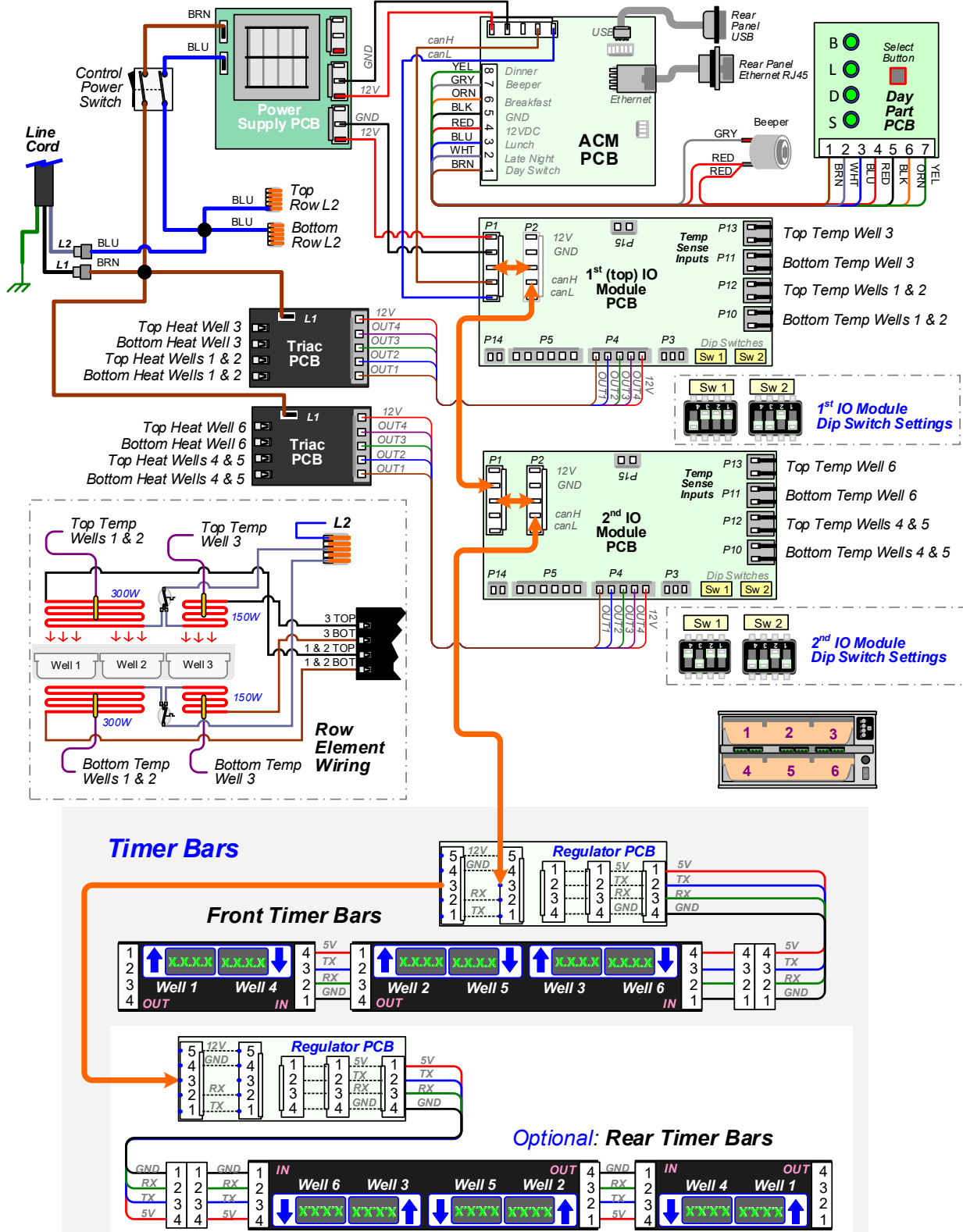

WIRE DIAGRAM

HS2-24, 4-Zone Models

WIRING DIAGRAM 2x4 HS2
225245 Rev. B 6/1/17

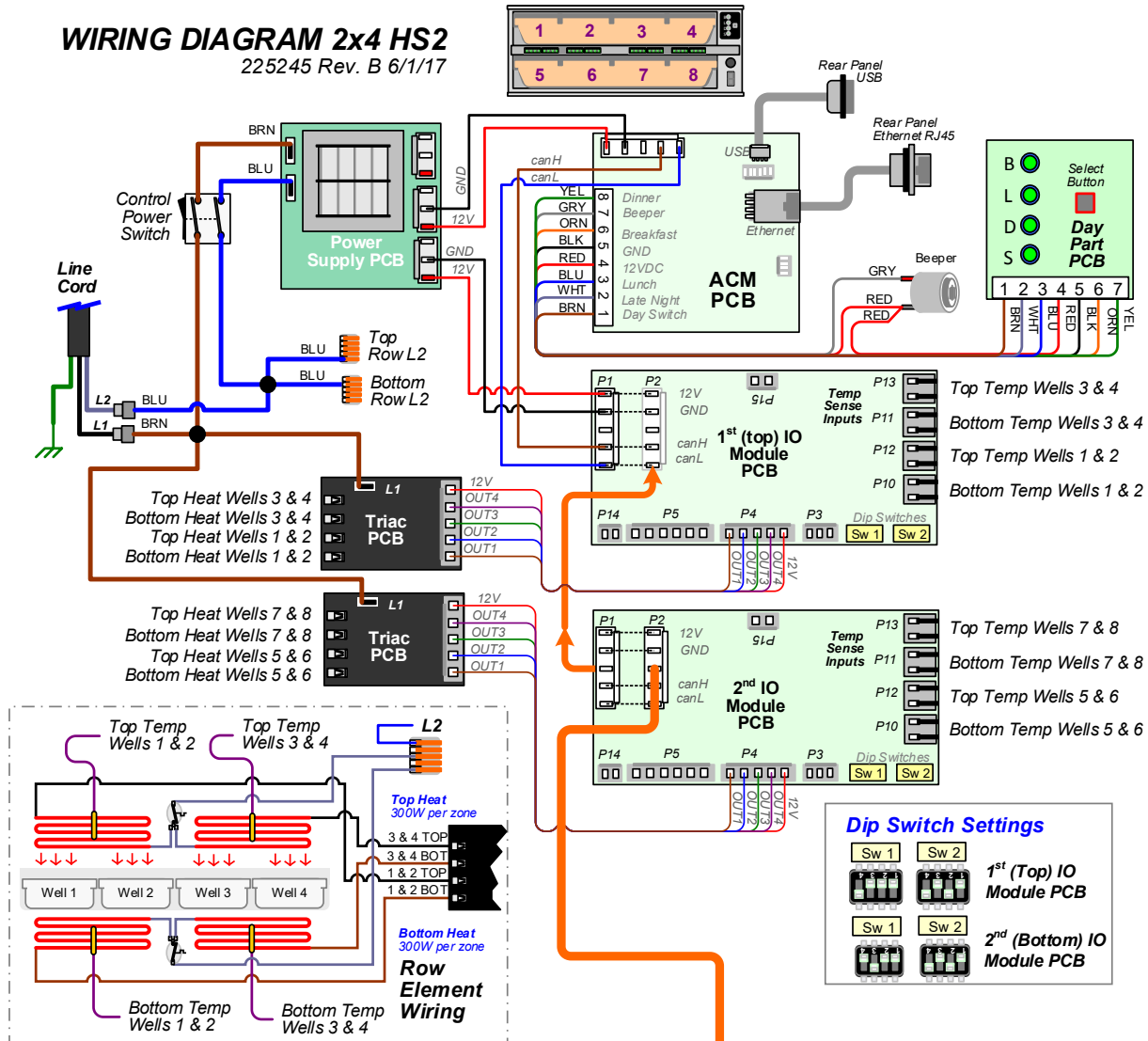

Timer Bars

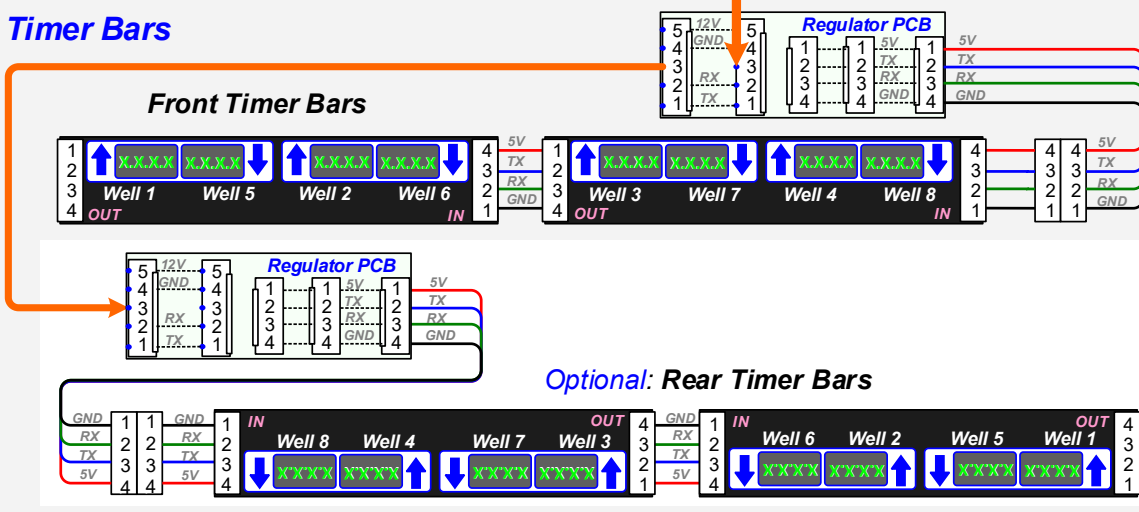

WIRE DIAGRAM

HS2-34, 6-Zone Models

WIRING DIAGRAM 3x4 HS2
225244 Rev. C 6/1/17

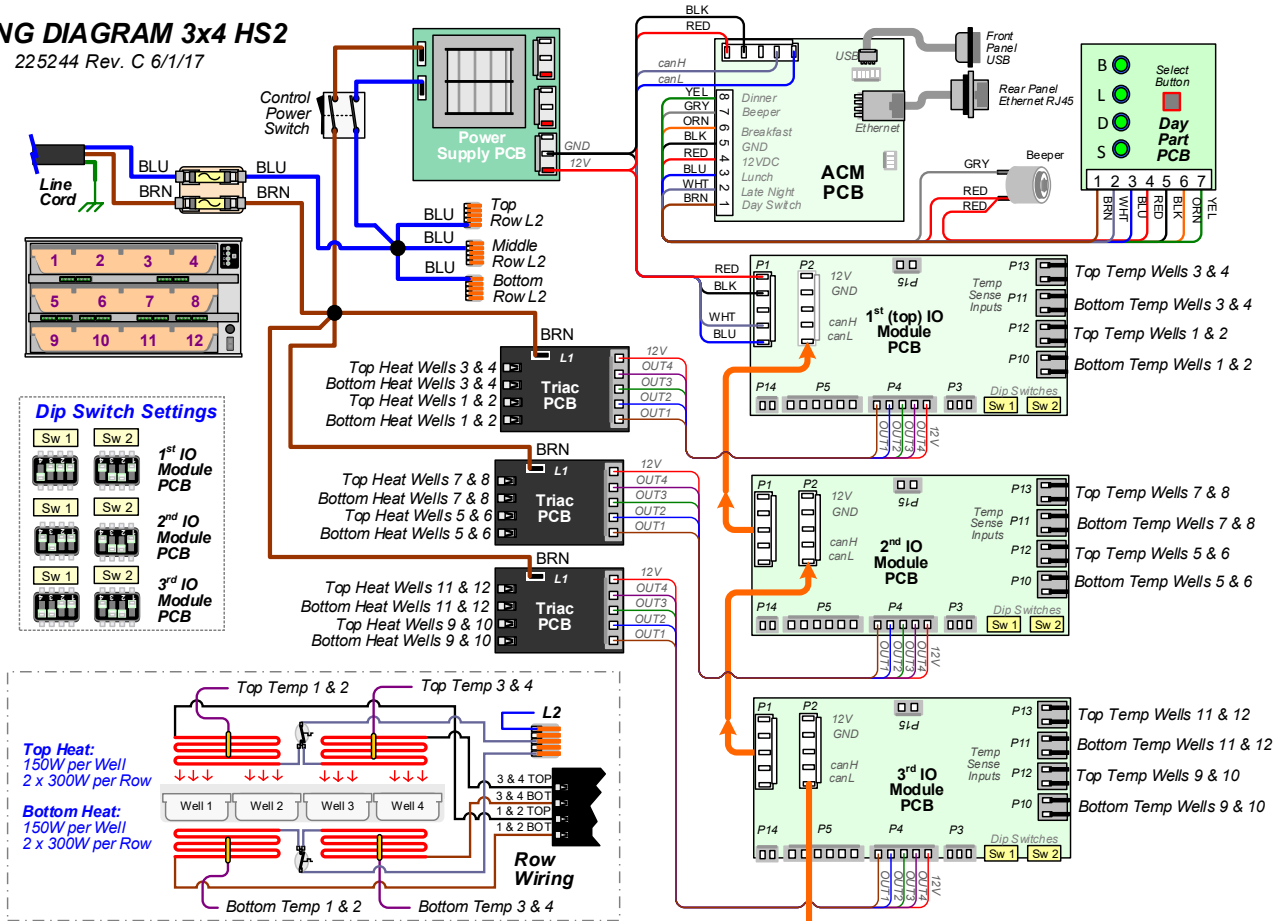

Timer Bars

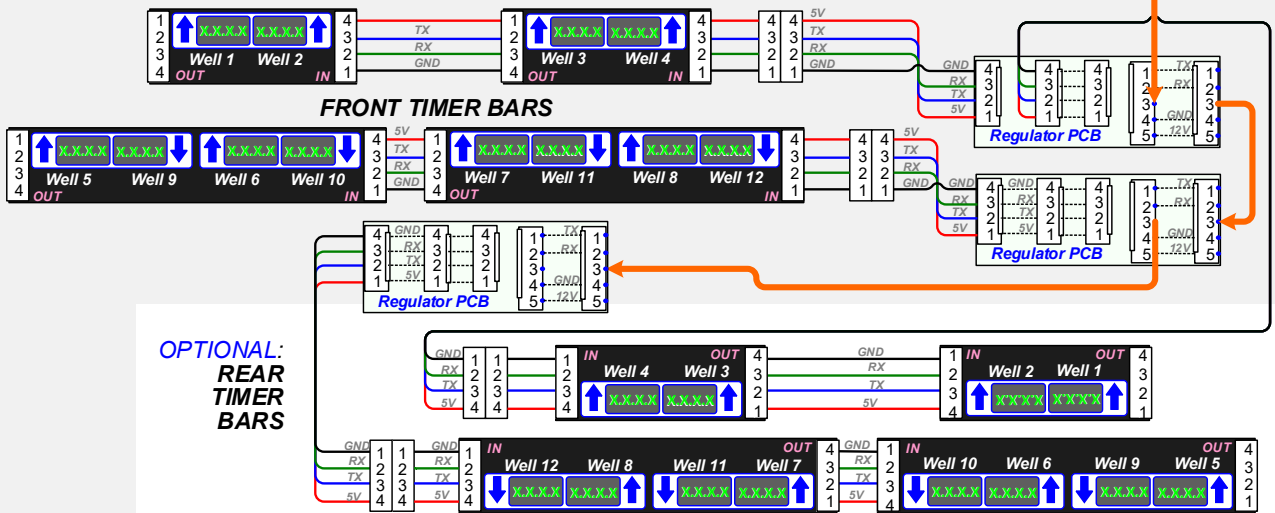

WIRE DIAGRAM

HS2-42, 4-Zone Models

WIRING DIAGRAM 4x2 HS2 225253 Rev. C 6/1/17

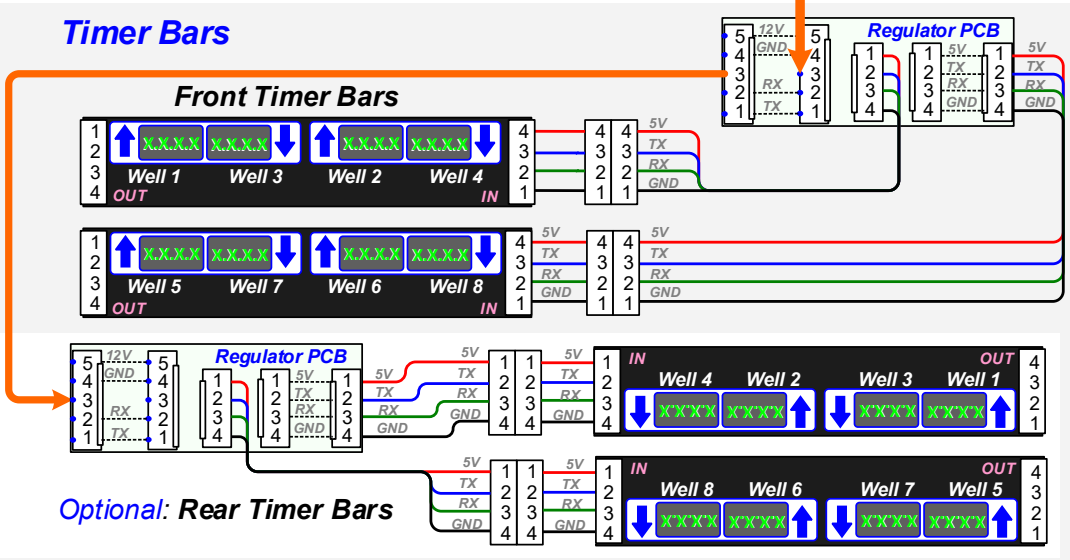
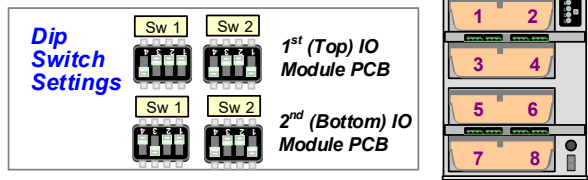
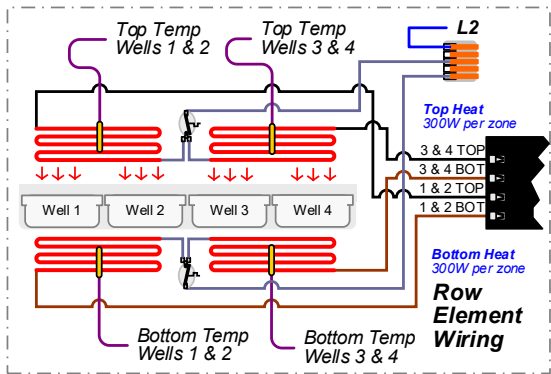
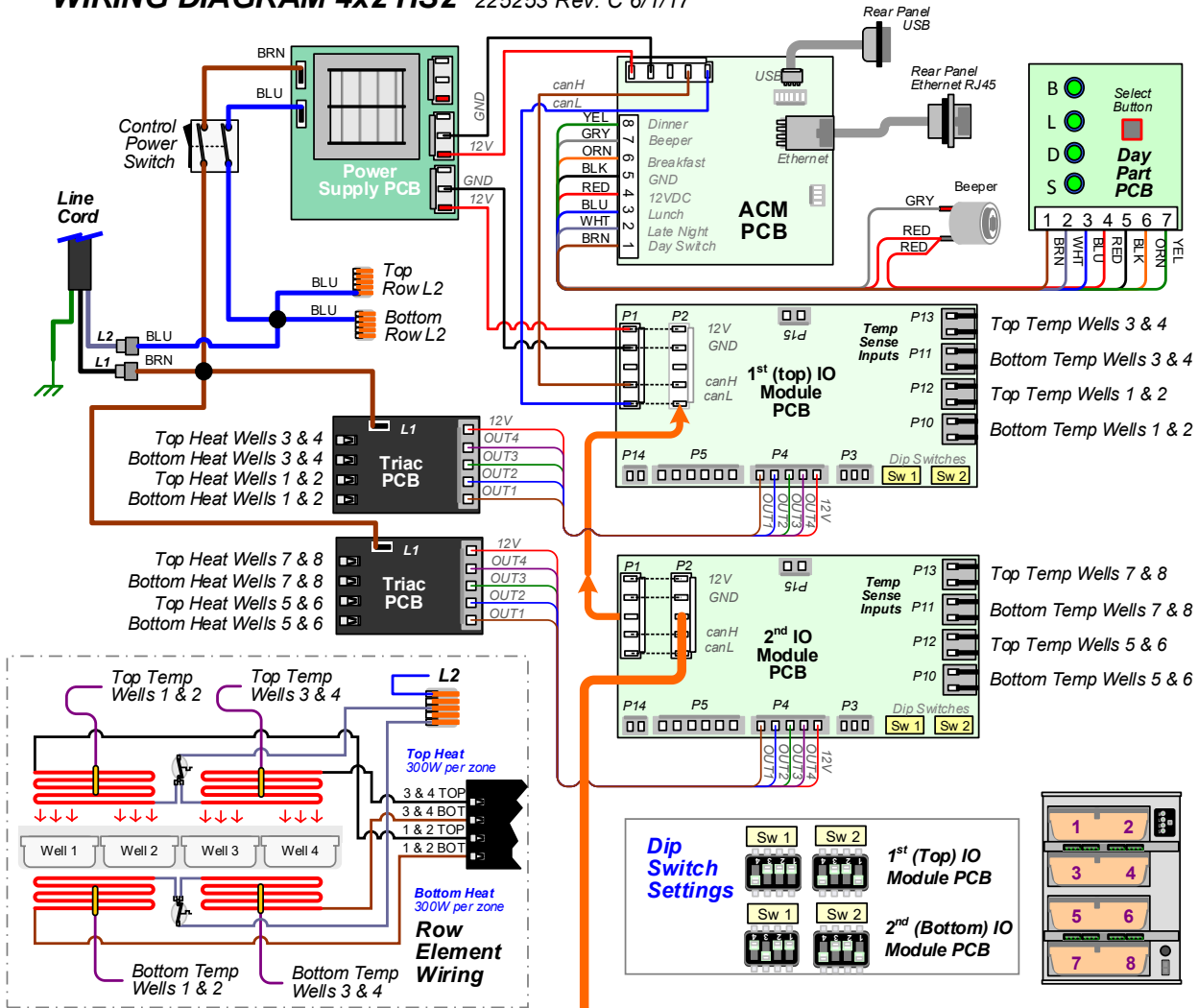

WIRE DIAGRAM

HS2-22, 2-Zone CE Models

WIRING DIAGRAM 2x2 HS2 - CE
ELC0229 Rev. B 8/23/19

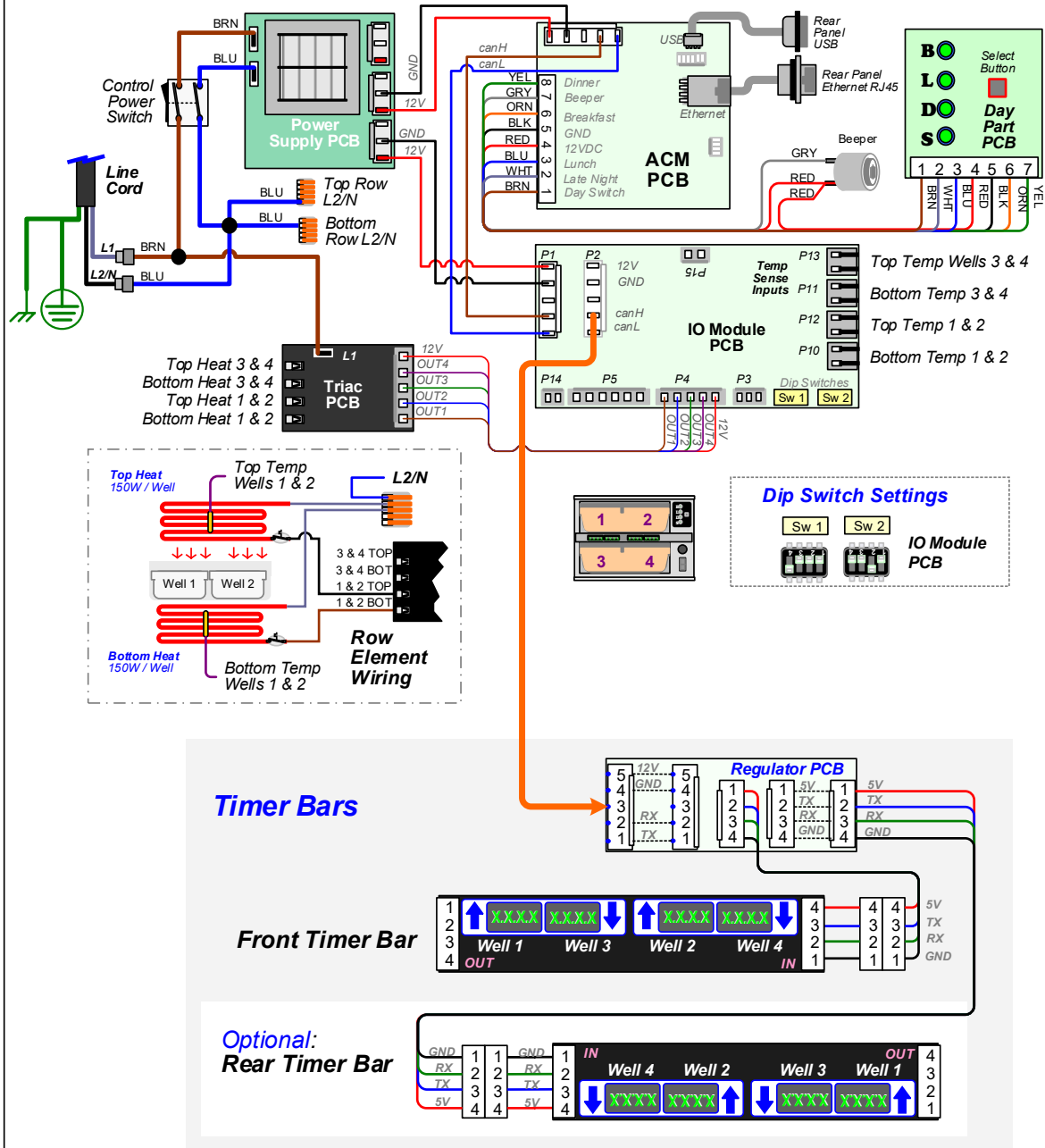

WIRE DIAGRAM

HS2-23, 4-Zone CE Models

Wire Diagram - HS2 Zoned 2 x 3 - CE

ELC0230 Rev. B (2x3_4z) 8/23/19

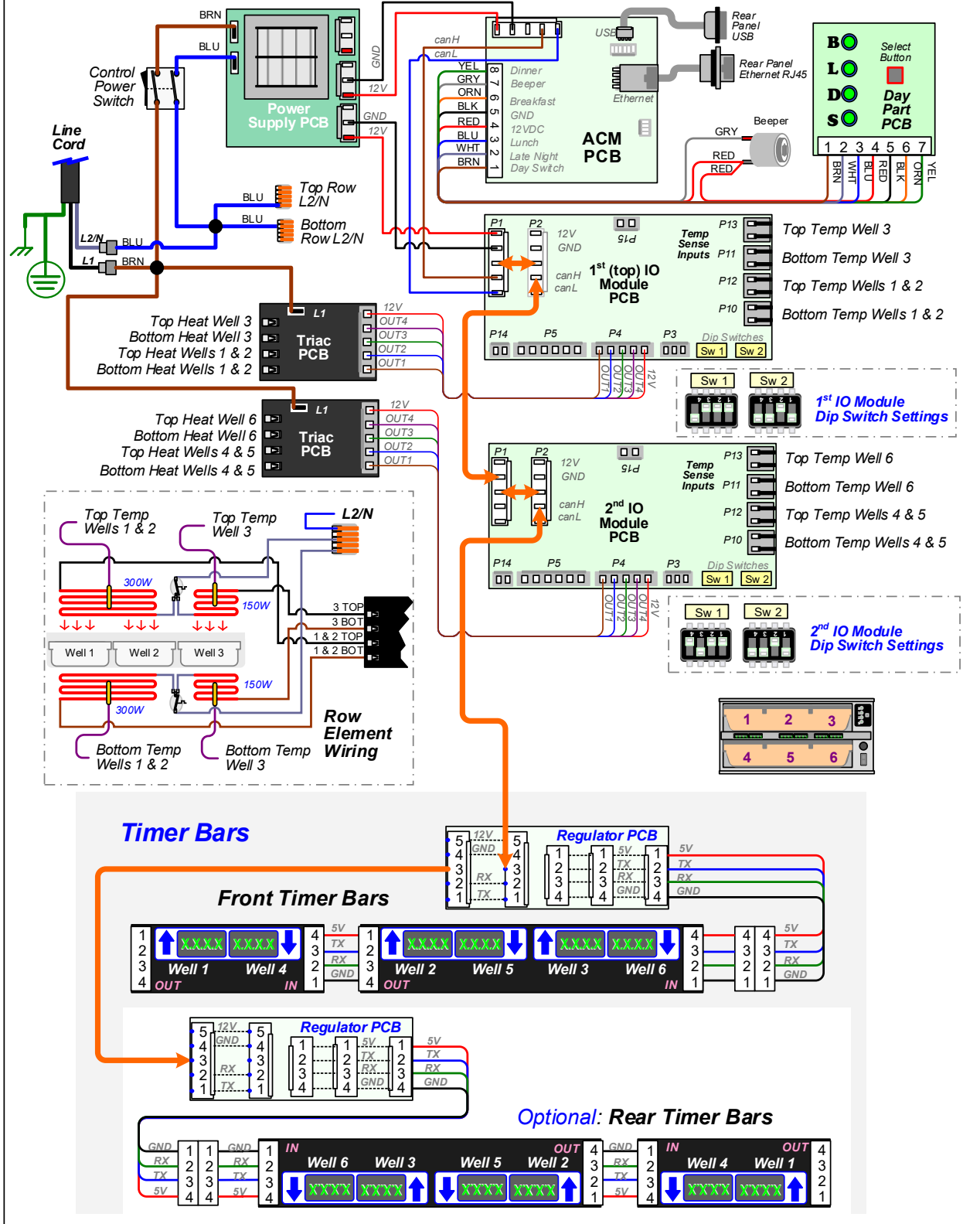

WIRE DIAGRAM

HS2-24, 4-Zone CE Models

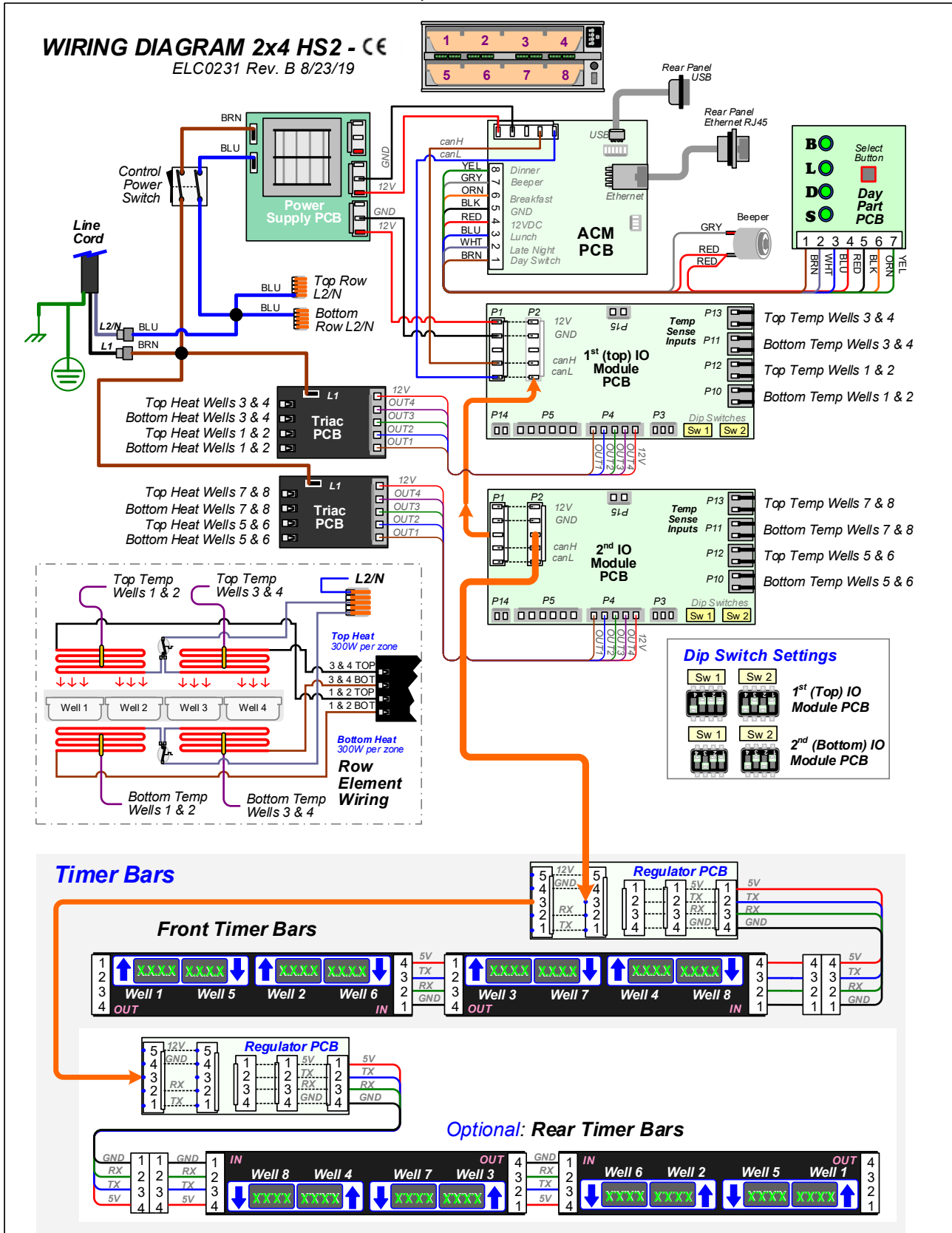

WIRE DIAGRAM

HS2-34, 6-Zone CE Models

WIRING DIAGRAM 3x4 HS2 - CE
ELC0232 Rev. B 8/23/19

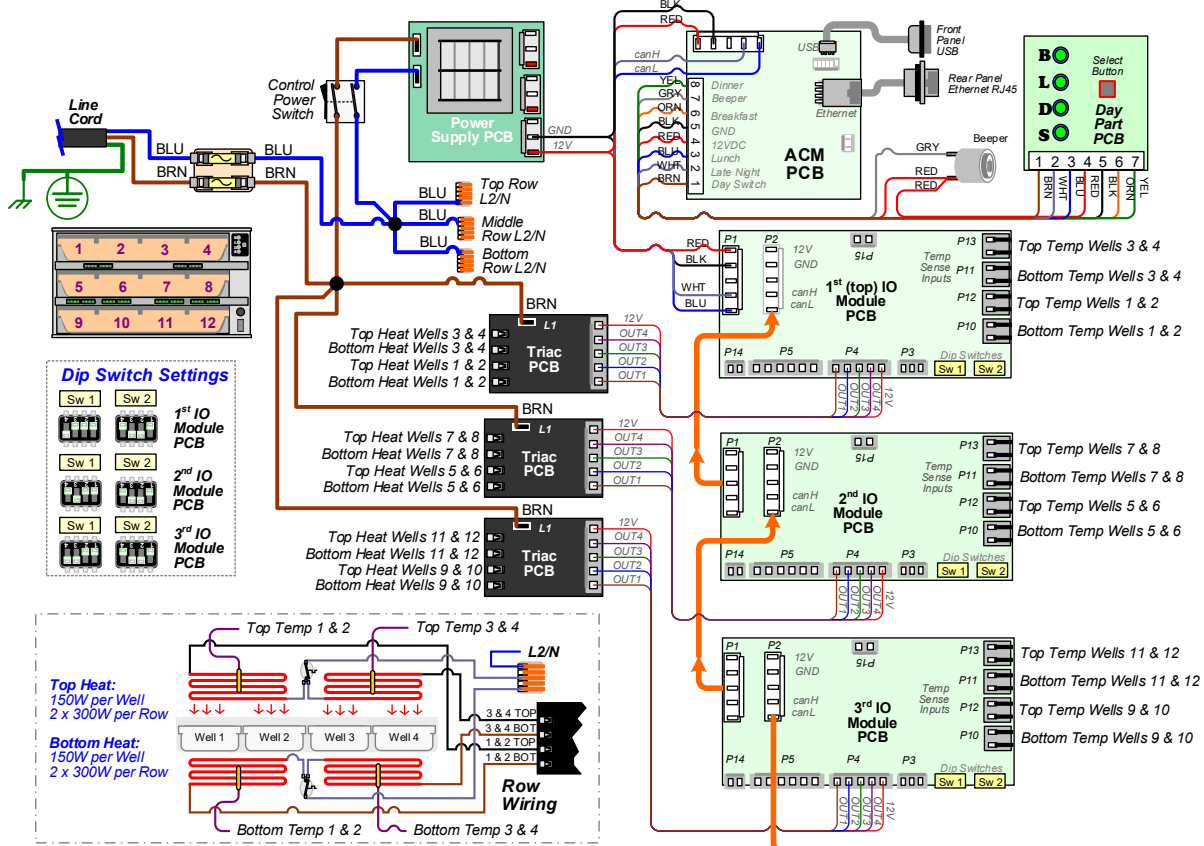

Timer Bars

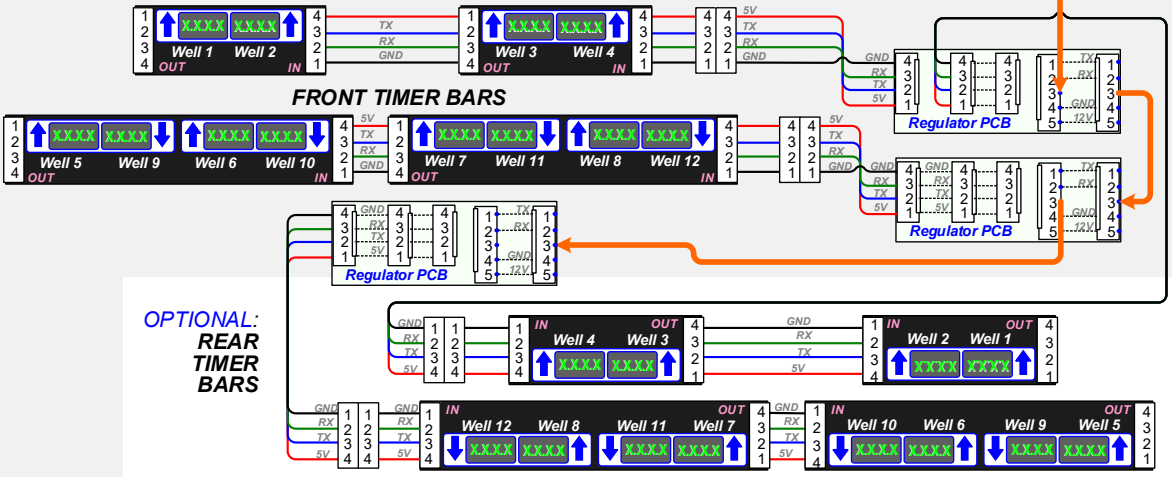

WIRE DIAGRAM

HS2-42, 4-Zone CE Models

WIRING DIAGRAM 4x2 HS2 ELC0233 - CE Rev. B 8/23/19

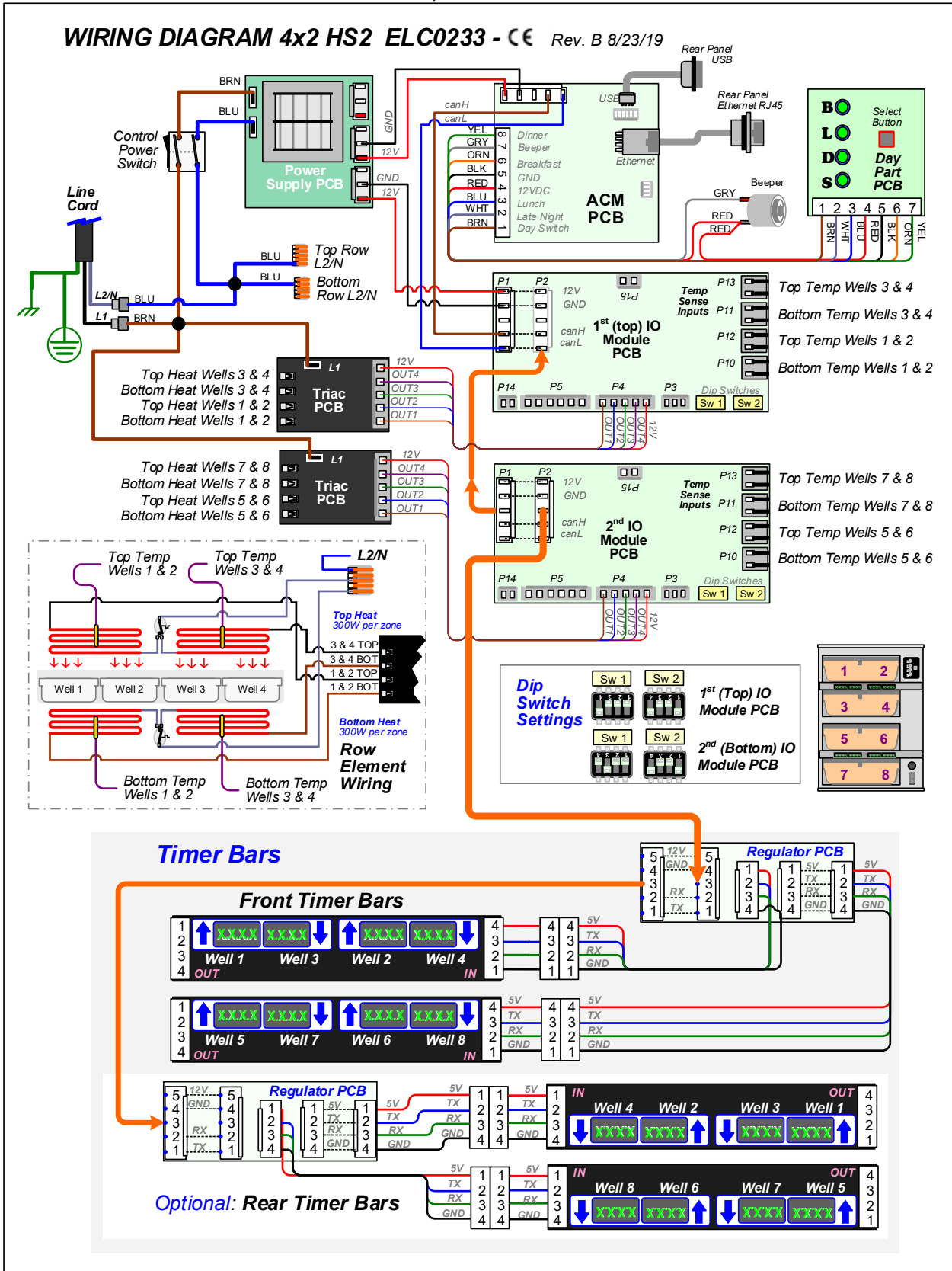

Wire Diagram - HS2 Zoned 2x3 120V

ELC0357 Rev. B 6/7/19

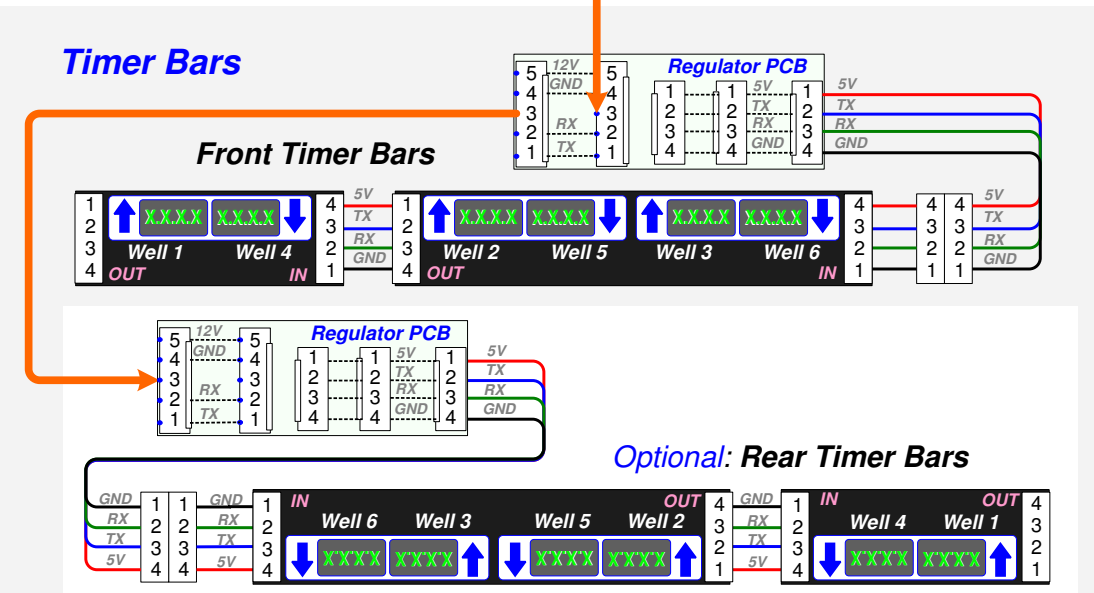
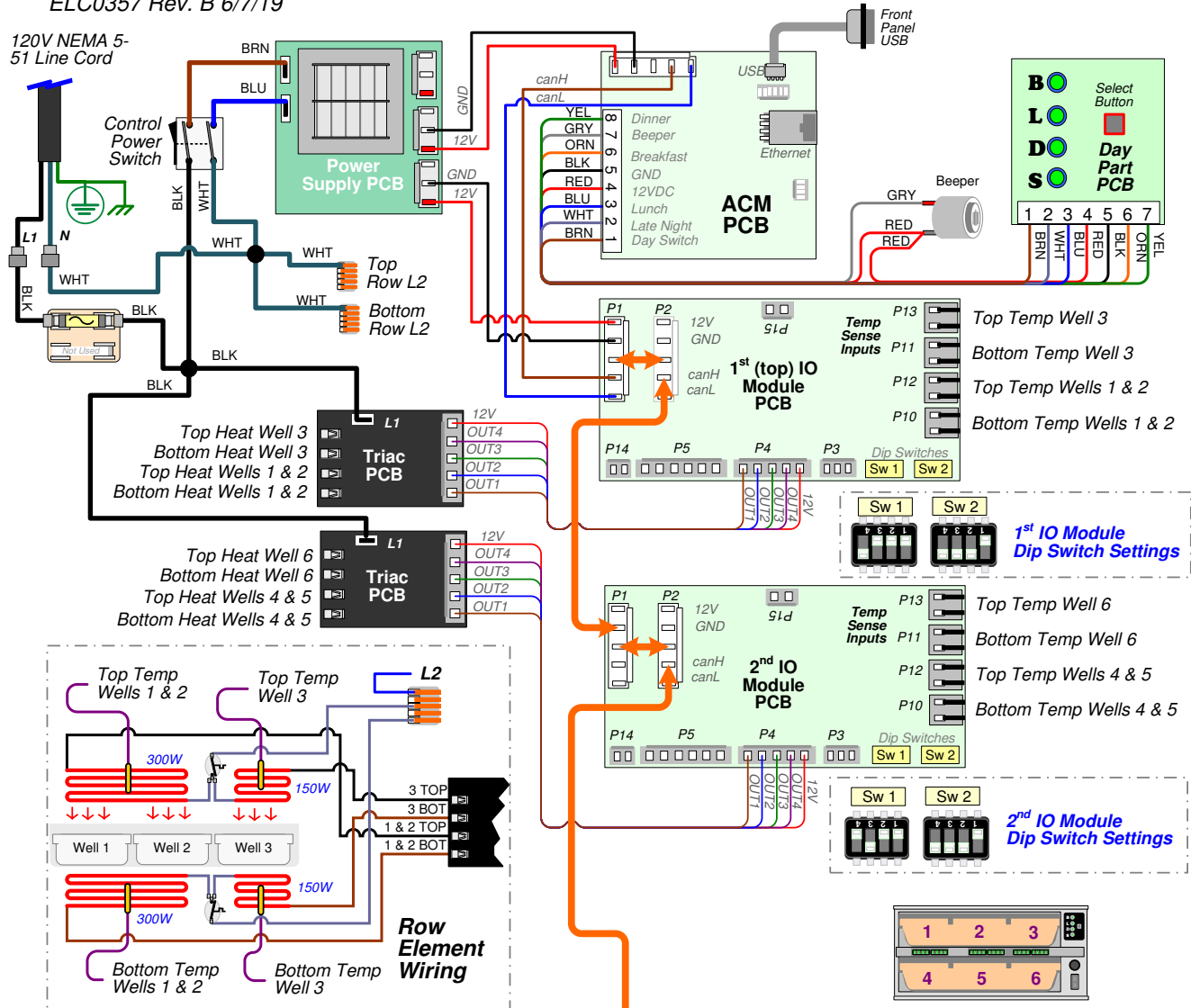

WIRING DIAGRAM HS2 2x4 120V
ELC0358 Rev. B 6/719

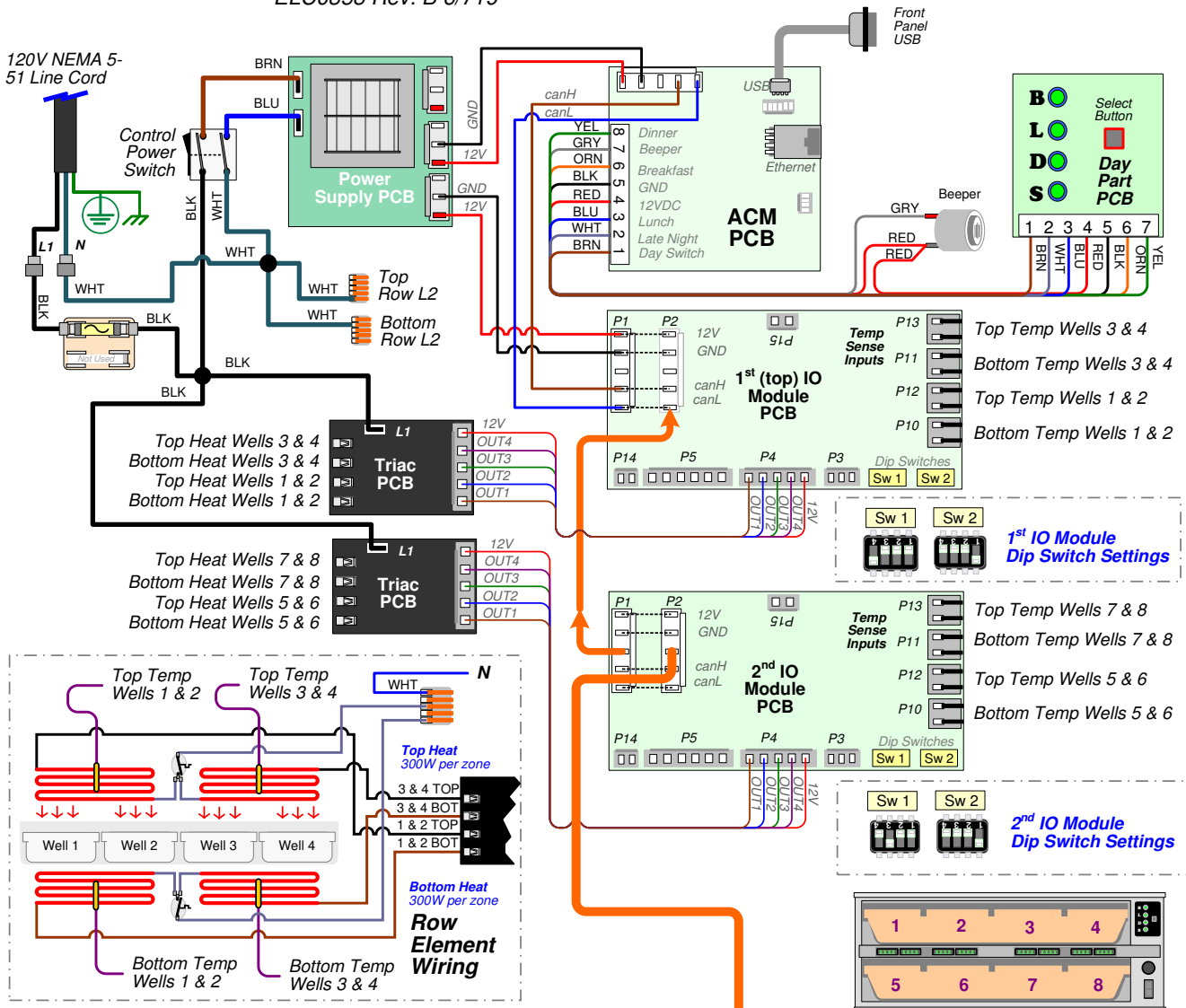

Timer Bars

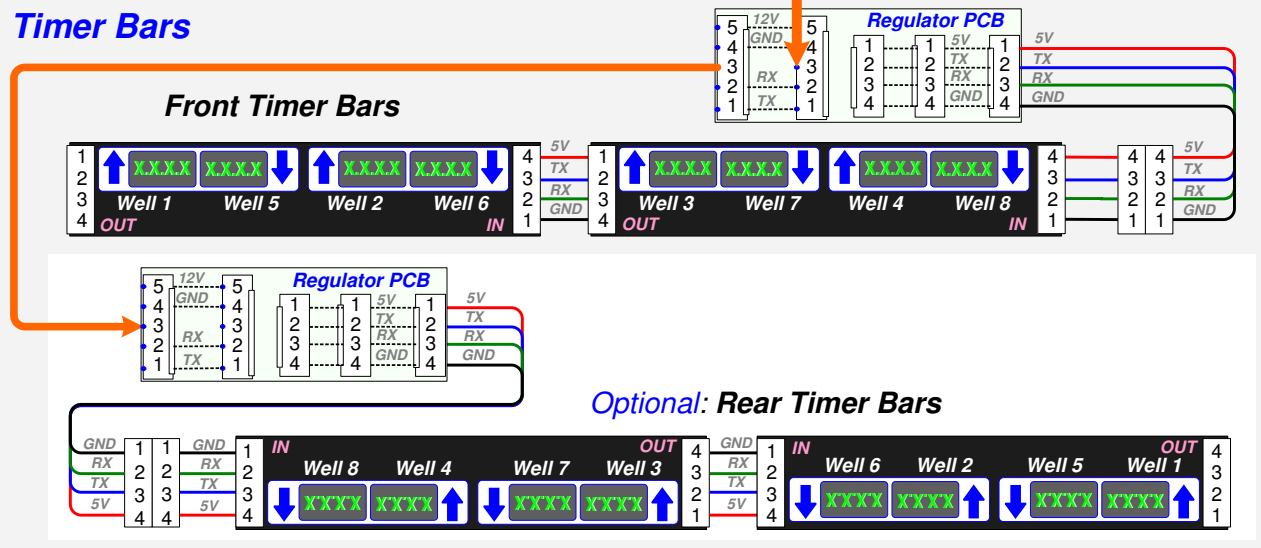



Your Solutions Partner

Duke Manufacturing Company

**2305 N. Broadway
St. Louis, MO 63102
Phone: 314-231-1130
Toll Free: 1-800-735-3853
Fax: 314-231-5074
www.dukemfg.com**