

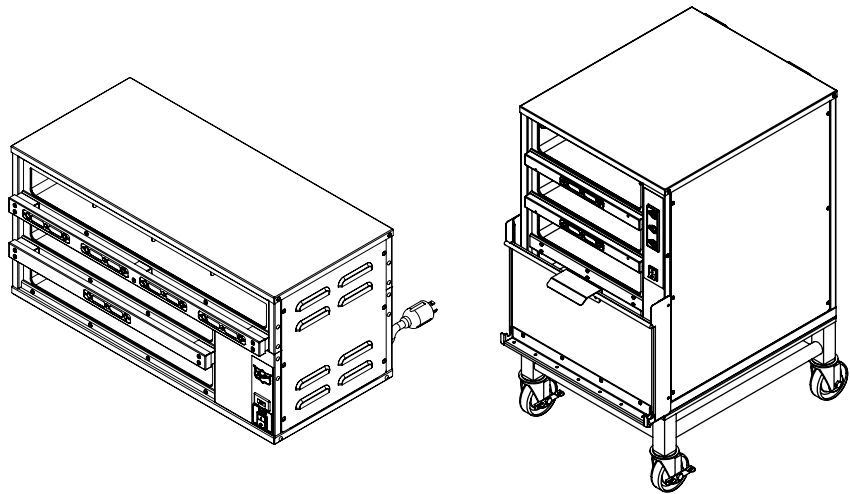

Your Solutions Partner

Illustrated Parts List



MUHC

(Multi-Use Holding Cabinet)

Models:

MUHC-34-208

MUHC-34SM-208

MUHC-34CH-208

MUCH-34CH-230

MUCH-51-120

MUCH-51-208

MUCH-51PRS-230CE

MUCH-52-120

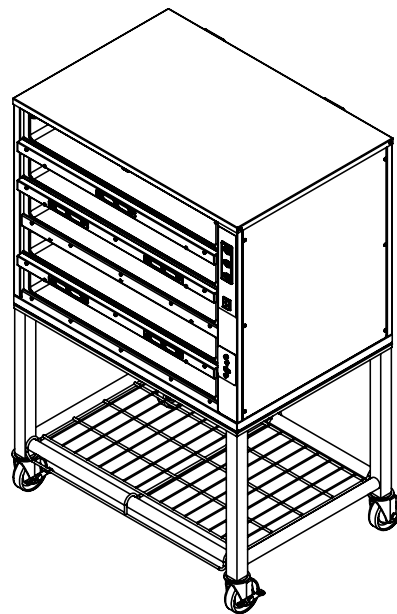

*This manual is Copyright © 2020 Duke Manufacturing Co. All rights reserved.
Reproduction without written permission is prohibited. Duke is a registered
trademark of the Duke Manufacturing Co.*

Duke Manufacturing Co.

2305 N. Broadway • St. Louis, MO 63102

800.735.3853 • 314.231.1130

Fax: 314-231-5074

www.dukemfg.com

TABLE OF CONTENTS

Models, MUHC-34-208, MUHC-34SM-208, MUHC-34CH-208 & MUHC-34CH-230	4
Models, MUHC-51-120, MUHC-51CB1-208, MUHC-51PR5-230CE & MUHC-52-120	6
WIRE DIAGRAMS:	
MUHC-34-208	8
MUHC-34SM-208.....	9
MUHC-34CH-208/230	10
MUHC-51-120/208	11
MUHC-52-120	12

MODELS - MUHC-34, MUHC-34SM, MUHC-34CH

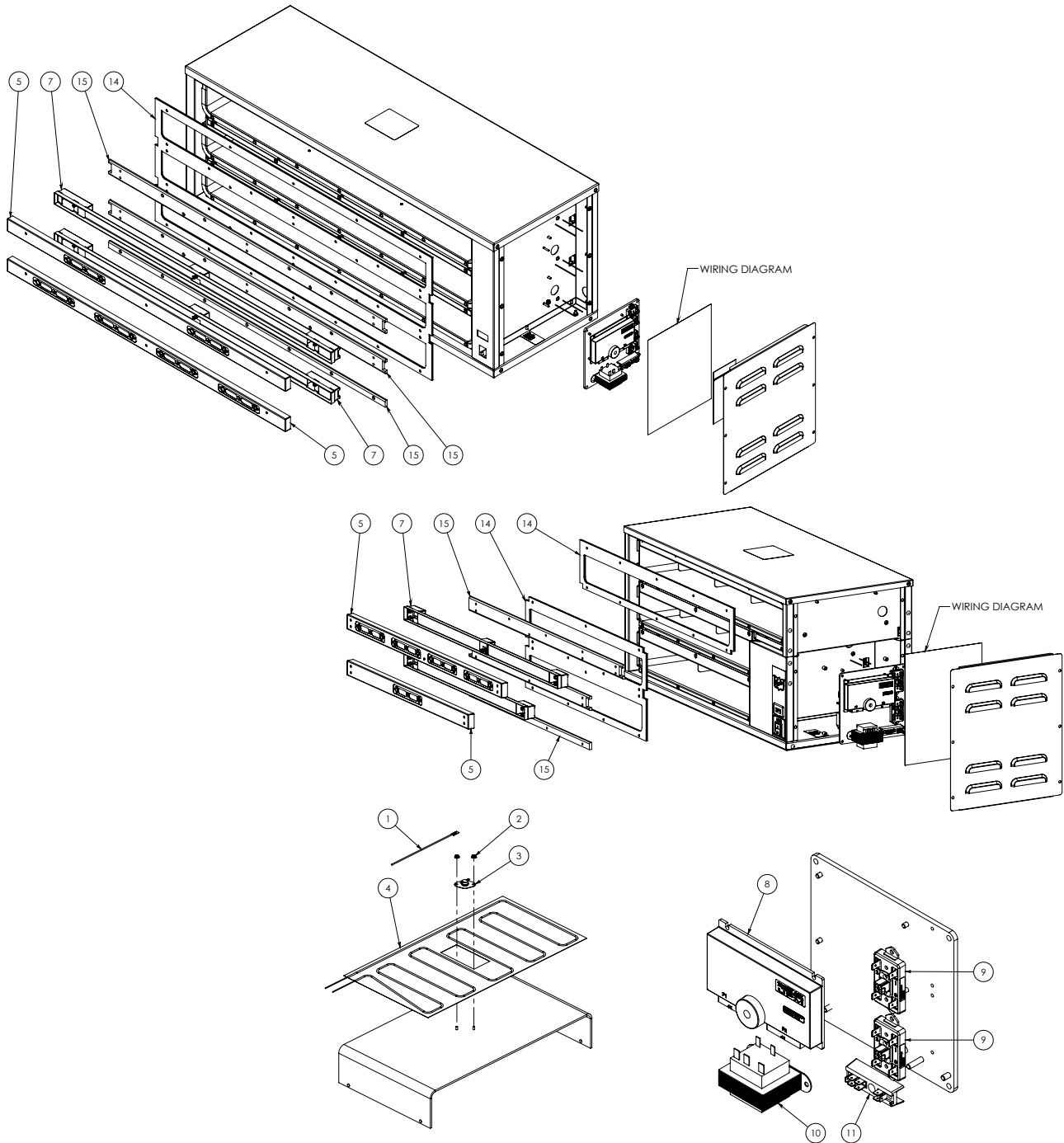

ITEM	PART #	DESCRIPTION	MUHC-34 208	MUHC 34SM 208	MUHC 34CH 208	MUHC 34CH 230
1	157725	RTD ASSEMBLY,1000 OHM 54"	3	3	3	3
2	155680	NUT #8-32 KEPS	6	6	6	6
3	158312	THERMOSTAT, AUXILIARY	3	3	3	3
4	165973	ELEMENT, 208V	3			
	165963	ELEMENT, TOP, 208V		1	1	
	165964	ELEMENT, BOT, 208V		2	2	
	165965	ELEMENT, TOP, 230V				1
	165966	ELEMENT, BOT, 230V				2

MODELS - MUHC-34, MUHC-34SM, MUHC-34CH

ITEM	PART #	DESCRIPTION	MUHC-34-208	MUHC-34SM-208	MUHC-34CH-208	MUHC-34CH-230
5	165430	TIMER BAR, 34, TOP	2			
	165431	TIMER BAR, 34, BOTTOM	2			
	165360	TIMER BAR, 34SM, TOP		1		
	165361	TIMER BAR, 34SM, BOTTOM		1		
	165362	TIMER BAR, 34CH, TOP			1	1
	165363	TIMER BAR, 34CH, BOTTOM			1	1
6	156735	KEYPAD - UP ARROWS FRONT ONLY (Serial # 05 16 2190 and Before)	2	2		
	157828	KEYPAD - UP DOWN ARROWS (Serial # 05 16 2190 and Before)	8		4	4
	156292	KEYPAD - DOWN ARROWS FRONT ONLY (Serial # 05 16 2190 and Before)			1	1
	160585	KEYPAD - DOWN ARROWS REAR ONLY (Serial # 05 16 2190 and Before)	2			
	161376	KEYPAD - UP DOWN ARROWS (Serial # 05 16 2190 and After)	8	2	4	4
	161377	KEYPAD - DOWN ARROWS (Serial # 05 16 2190 and After)			1	1
	161378	KEYPAD - UP ARROWS (Serial # 05 16 2190 and After)	4	2		
7	165447	TIMER BAR BACKER, TOP	2			
	165446	TIMER BAR BACKER, BOTTOM	2			
	165488	TIMER BAR BACKER, SM34, TOP		1		
	165490	TIMER BAR BACKER, SM34, BOTTOM		1		
	165489	TIMER BAR BACKER, 34CH, TOP			1	1
	165491	TIMER BAR BACKER, 34CH, BOTTOM			1	1
8	157829	CONTROL, MAIN	1	1	1	1
9	157830-K	RELAY KIT, SMART POWER MODULE	2	2	2	2
10	155749	TRANSFORMER, 208/240 VAC	1	1	1	
	156838	TRANSFORMER, 230 VAC				1
11	157743	TERMINAL BLOCK	1	1	1	1
12	157965	FILTER, 16A				1
13	600261	SWITCH, LIGHTED, DPST, 250V 16A	1	1	1	1
14	165436	FACEPLATE W/GASKET	2			
	165378	FACEPLATE W/GASKET, TOP, 34SM		2		
	165379	FACEPLATE W/GASKET, BOTTOM, 34SM		2		
	165380	FACEPLATE W/GASKET, TOP, 34CH			2	2
	165381	FACEPLATE W/GASKET, BOTTOM, 34CH			2	2
15	165976	STRIP, PLASTIC, TOP	4			
	165975	STRIP, PLASTIC, BOTTOM	2			
	165957	STRIP, PLASTIC, TOP, FRONT		1	1	1
	165958	STRIP, PLASTIC, TOP, REAR		1	1	1
	165956	STRIP, PLASTIC, MIDDLE		2	2	2
	165955	STRIP, PLASTIC, BOTTOM		2	2	2
16	159243	CORD, NEMA 6-15P, 208/240V	1	1	1	
	160852	CORD ASY, 3PIN 230V				1
	160486	STRAIN RELIEF	1	1	1	1
17	157916	DAYPART SWITCH (OPTIONAL)			1	1

MODELS - MUHC-51-120, MUHC-51-208, MUHC-51PR5-230CE, MUHC-52-120

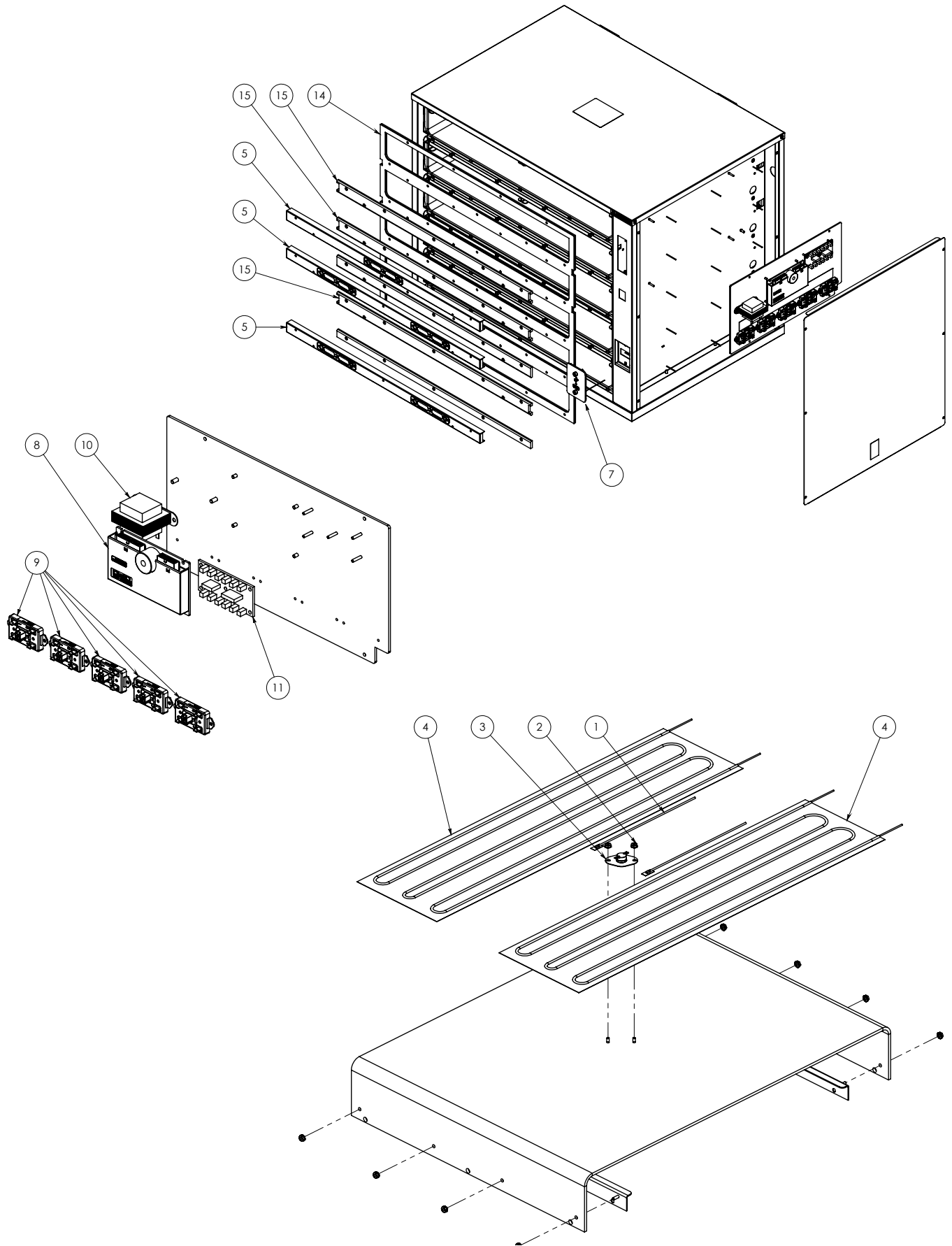

MODELS - MUHC-51-120, MUHC-51-208, MUHC-51PR5-230CE, MUHC-52-120

ITEM	PART #	DESCRIPTION	MUHC-51-120	MUHC-51CB1-208	MUHC 51PR5-230CE	MUHC-52-120
1	158279	RTD, 1K OHM, MEDIUM	10	10	10	10
2	155680	NUT #8-32 KEPS	50	50	50	50
3	158312	THERMOSTAT, AUXILIARY	5	5	5	5
4	165910	ELEMENT, 51 - 120V	10			
	165978	ELEMENT, 51 - 208V		10		
	165911	ELEMENT, 52 - 120V				10
	165989	ELEMENT, 51 - 230V			10	
5	165145	TIMER BAR, 51, TOP	1			
	165144	TIMER BAR, 51	2			
	165155	TIMER BAR, 51 UP/UP		1	1	
	165154	TIMER BAR WITH STANDOFF, 51		2	2	
	165245	TIMER BAR, TOP, 52				1
	165246	TIMER BAR, BOT, 52				2
6	156735	KEYPAD - UP ARROWS FRONT ONLY <i>(Serial #05 16 2190 and Before)</i>	1	1		1
	157828	KEYPAD - UP DOWN ARROWS <i>(Serial #05 16 2190 and Before)</i>	2	2		4
	161378	KEYPAD - UP ARROWS <i>(Serial #05 16 2190 and After)</i>	1	1	1	1
	161376	KEYPAD, UP - DOWN ARROWS <i>(Serial #05 16 2190 and After)</i>	2	2	2	4
7	165014	COVER, USB	1	1	1	1
8	157829	CONTROL, MAIN	1	1	1	1
9	157830-K	RELAY KIT, SMART POWER MODULE	5	5	5	5
10	156316	TRANSFORMER, 120 VAC	1			1
	155749	TRANSFORMER, 208/240V		1		
	156838	TRANSFORMER, 230V			1	
11	158337	RTD BOARD	1	1	1	1
12	157916	DAYPART SWITCH (OPTIONAL)	1	1	1	1
13	160406	SWITCH, 20A, 125V	1			1
	157886	SWITCH, 20A, 250V		1		
	156527	SWITCH, 16A, 250V			1	
14	165142	FACEPLATE W GASKET, 51	2	2	2	
	165243	FACEPLATE W GASKET, 52				2
15	165904	STRIP, PLASTIC, BOTTOM, 51	1	1	1	
	165905	STRIP, PLASTIC, SOLID, 51	3	3	3	
	165906	STRIP, PLASTIC, TIMER BAR, 51	1	1	1	
	165907	STRIP, PLASTIC, SOLID, 52				1
	165908	STRIP, PLASTIC, TIMER BAR, 52				3
	165909	STRIP, PLASTIC, BOTTOM, 52				1
16	156621	CORD, NEMA 5-20P, 120V	1			
	156624	CORD, NEMA 6-15P, 250V		1		
	165953	CORD, NEMA L5-30P, 125V				1
	156631	CORD, 16A, 230V CE			1	
17	165134	COVER, REAR, 51	1	1	1	
	165235	COVER, REAR, 52				1
	165942	CASTER, SWIVEL, WITH BRAKE	2	2		2
	165914	CASTER, FIXED, NO BRAKE	2	2		
	165943	CASTER, SWIVEL, NO BRAKE				2
Not Shown	165061K	KIT, MUHC LID SOLID	A/R	A/R	A/R	A/R
	165062K	KIT, MUHC LID VENTED	A/R	A/R	A/R	A/R

WIRE DIAGRAM, MUHC-34-208

P/N 165438 REV. B

MUHC 34 WIRING DIAGRAM

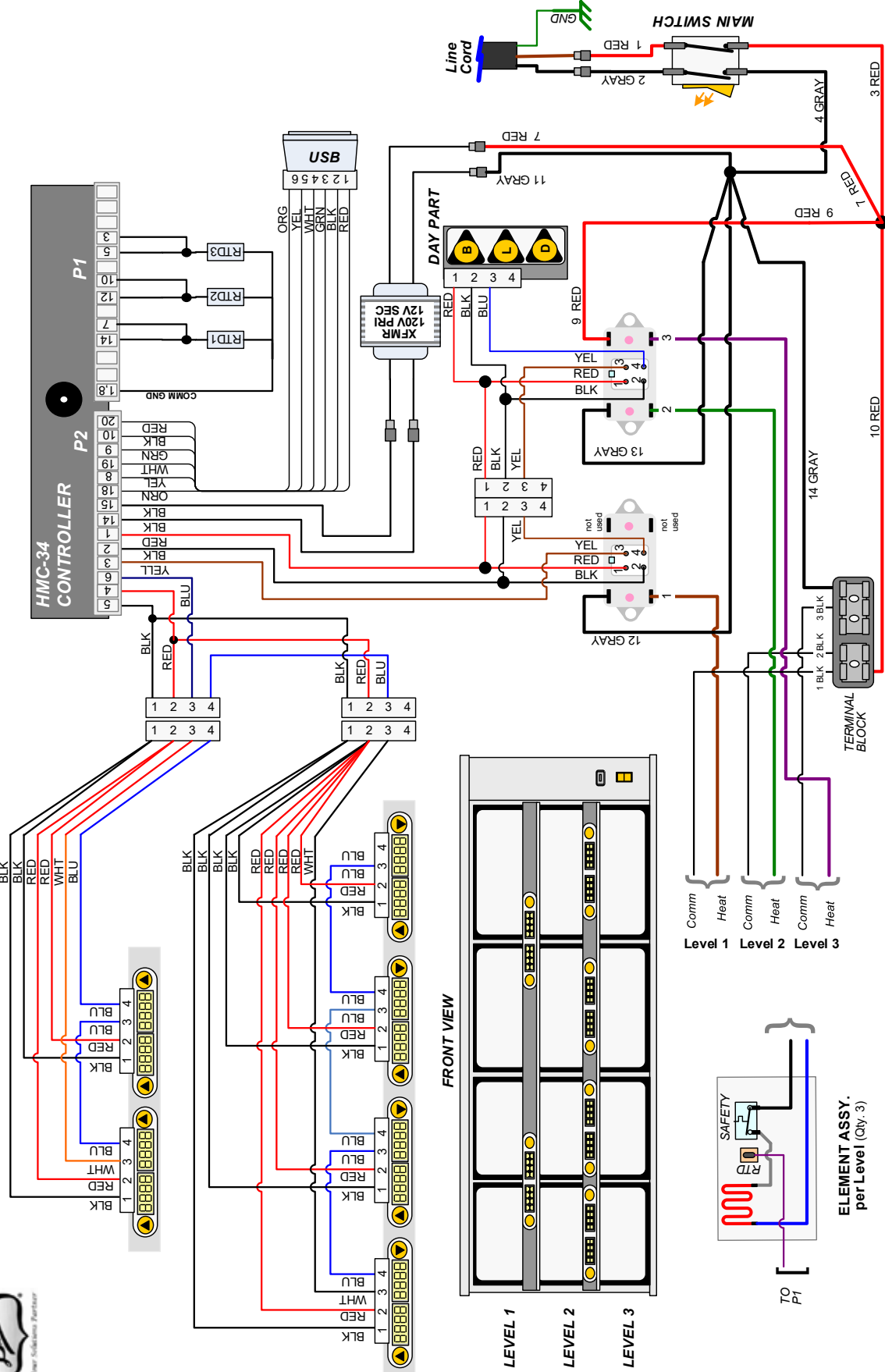

WIRE DIAGRAM, MUHC-34SM-208

P/N 165394 REV. C

MUHC 34SM WIRING DIAGRAM

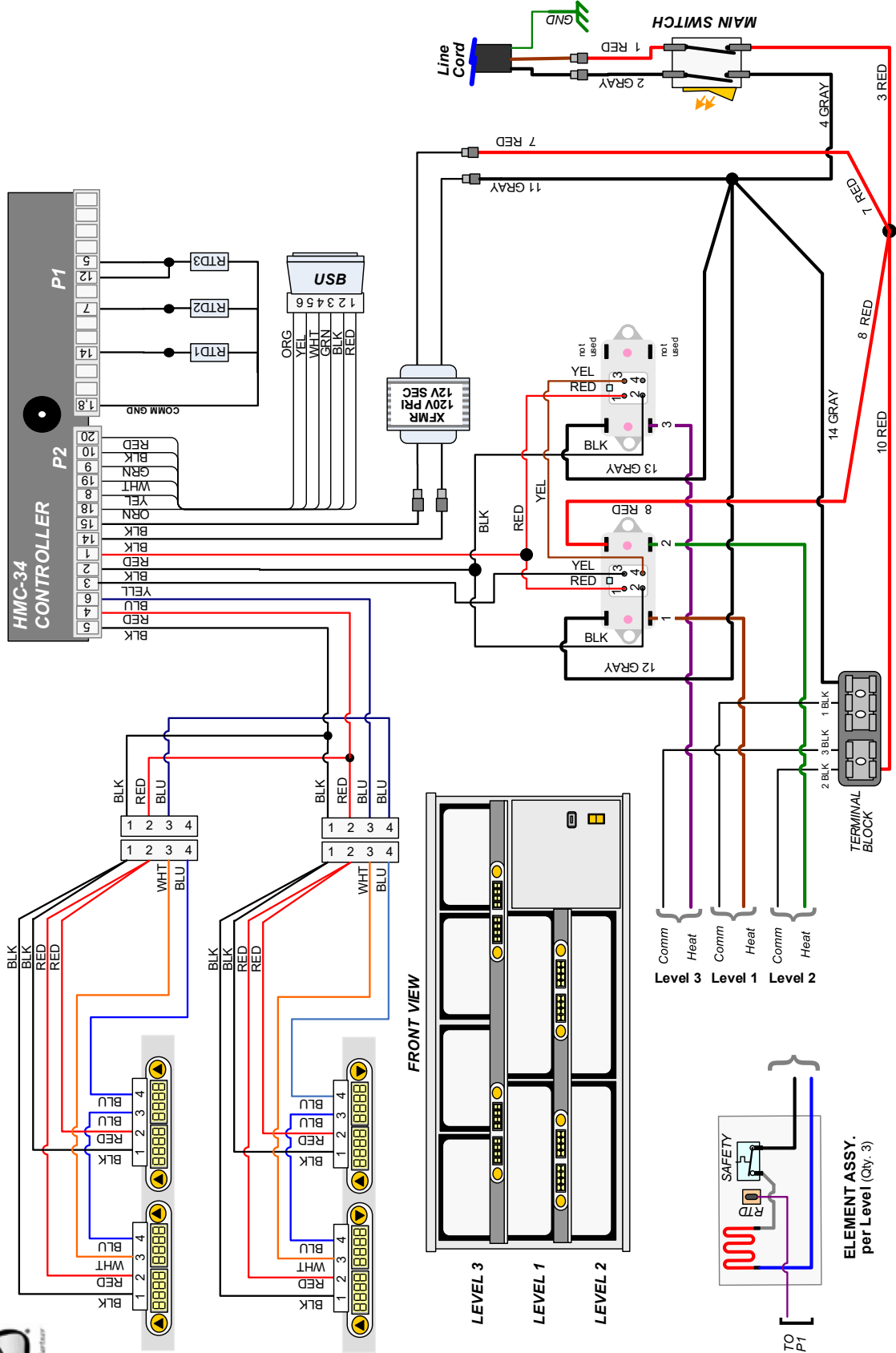

WIRE DIAGRAM, MUHC-34CH-208/230

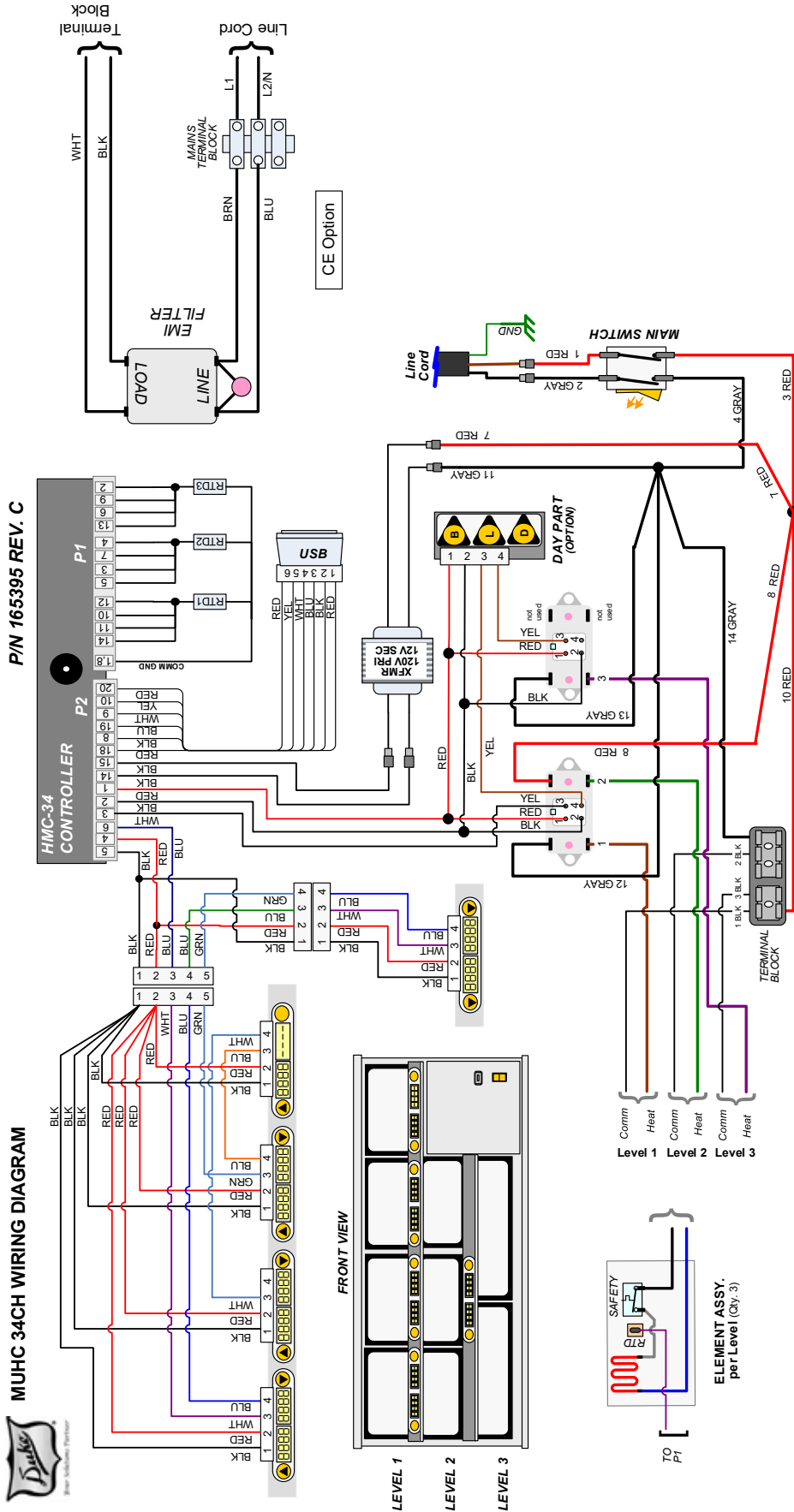

WIRE DIAGRAM, MUHC-51-120/208



MUHC 5X1 WIRING DIAGRAM

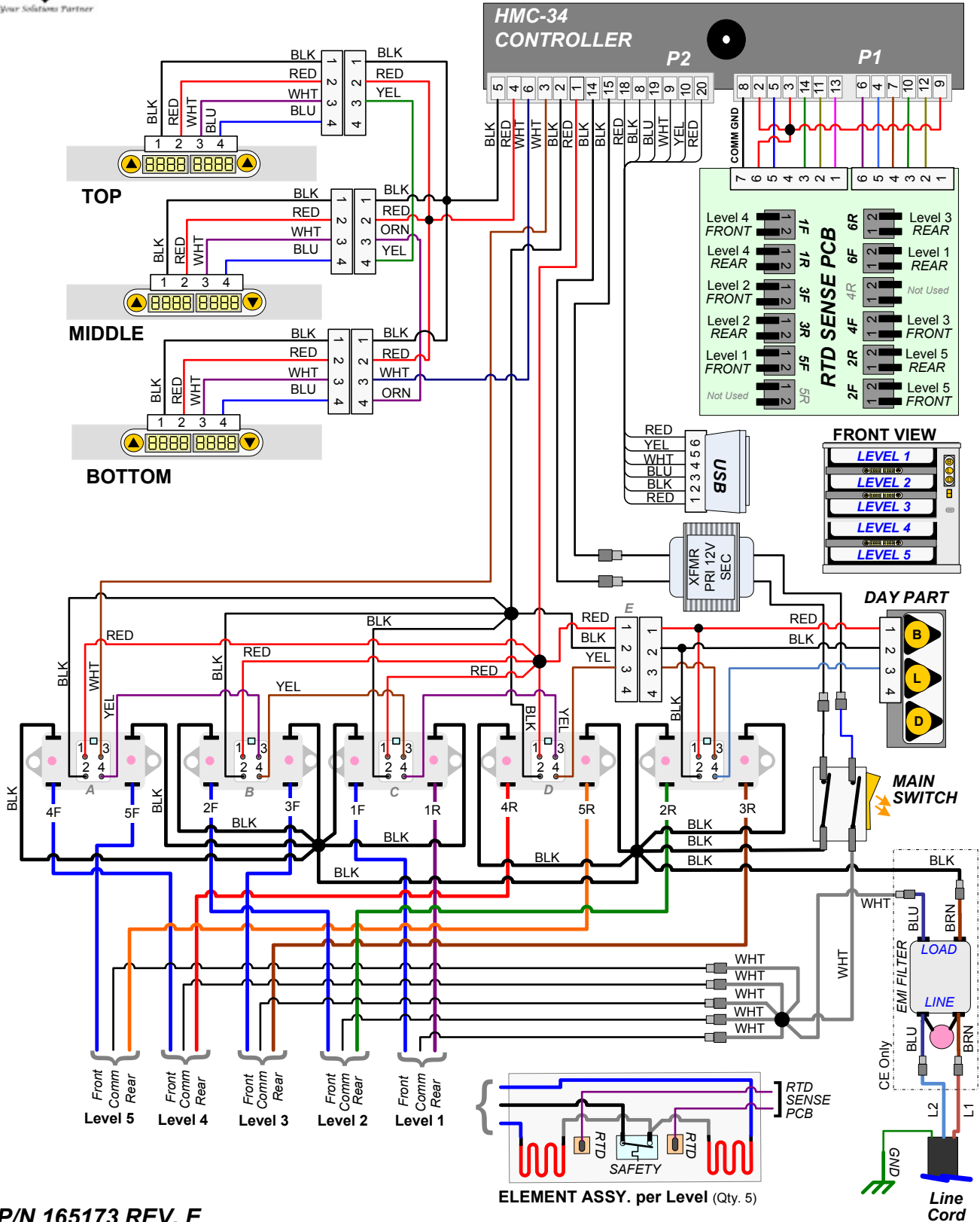

P/N 165173 REV. E

WIRE DIAGRAM, MUHC-52-120



MUHC 5X2 WIRING DIAGRAM

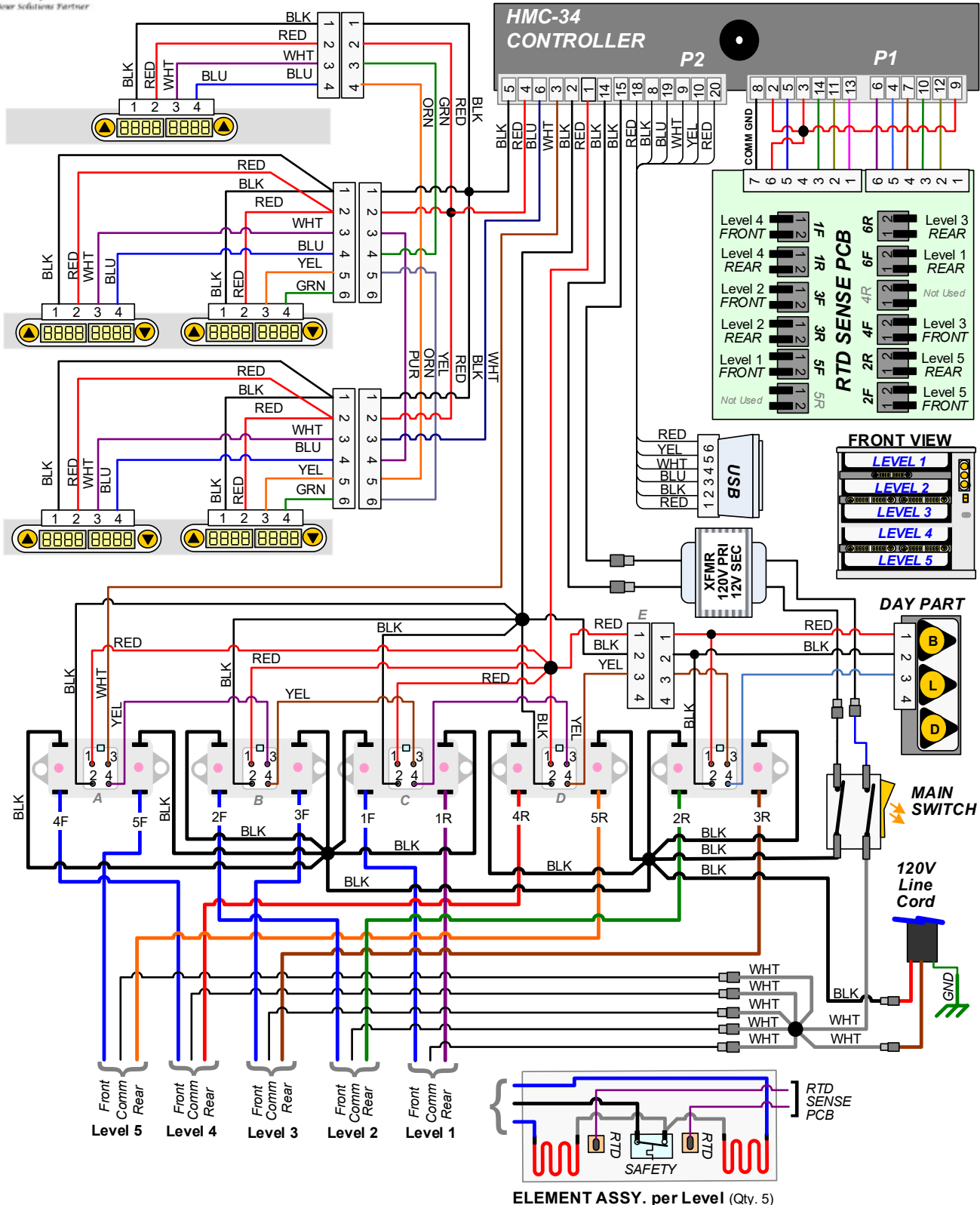

ELEMENT ASSY. per Level (Qty. 5)

P/N 165273 REV. B

NOTES:



Your Solutions Partner

Duke Manufacturing Company

**2305 N. Broadway
St. Louis, MO 63102
Phone: 314-231-1130
Toll Free: 1-800-735-3853
Fax: 314-231-5074
www.dukemfg.com**