



Service Manual



REFRIGERATED BASE

MODEL
RB 72

**Please read this manual completely before attempting to
install, operate or service this equipment**

*This manual is Copyright © 2011 Duke Manufacturing Company. All rights reserved.
Reproduction without written permission is prohibited. Duke is a registered
trademark of the Duke Manufacturing Company.*

Duke Manufacturing Company

2305 N. Broadway
St. Louis, MO 63102
Phone: 314-231-1130
Toll Free: 1-800-735-3853
Fax: 314-231-5074
www.dukemfg.com

IMPORTANT WARNING AND SAFETY INFORMATION

WARNING

READ THIS MANUAL THOROUGHLY BEFORE OPERATING, INSTALLING, OR PERFORMING MAINTENANCE ON THE EQUIPMENT.

WARNING

FAILURE TO FOLLOW INSTRUCTIONS IN THIS MANUAL CAN CAUSE PROPERTY DAMAGE, INJURY OR DEATH.

WARNING

DO NOT STORE OR USE GASOLINE OR OTHER FLAMMABLE VAPORS OR LIQUIDS IN THE VICINITY OF THIS OR ANY OTHER APPLIANCE.

WARNING

UNLESS ALL COVER AND ACCESS PANELS ARE IN PLACE AND PROPERLY SECURED, DO NOT OPERATE THIS EQUIPMENT.

CAUTION

Observe the following:

- Minimum clearances must be maintained from all walls and combustible materials.
- Keep the equipment area free and clear of combustible material.
- Adequate clearance for air openings.
- Operate equipment only on the type of electricity indicated on the specification plate.
- Retain this manual for future reference.

CONTENTS

SPECIFICATIONS	4
INSTALLATION	4
Location	4
Inside Unit.....	4
Outside Unit.....	4
Leveling	4
Stabilizing	4
Electrical Connection	4
MAINTENANCE	5
Stainless Steel Care and Cleaning	5
PREVENTIVE MAINTENANCE.....	6
Cleaning the Condenser Coil.....	6
Door Gasket Maintenance.....	6
Drain Maintenance – Base	7
PARTS REPLACEMENT	7
Thermostat Replacement	7
Evaporator Fan Replacement.....	8
Refrigeration System Replacement.....	8
Door and Hinge Replacement	9
Door Gasket Replacement	9
Recharging Refrigeration System.....	9
Tools	9
Charging Procedure	9
Heater Thermostat Replacement.....	10
Heating Element Replacement.....	10
TROUBLESHOOTING	11

SPECIFICATIONS

MODEL	DESCRIPTION	VOLTAGE	AMPS	PH.
RB 72	72" Refrigerated Base	120 VAC (60 Hz)	8.8	1
		220 VAC (50 Hz)	4.4	1
MODEL	DESCRIPTION	HEIGHT	WIDTH	LENGTH
RB 72	72" Refrigerated Base	38.00 In.	33.50 In.	72.00 In.

INSTALLATION

Location

The unit represented in this manual is intended for indoor use only. Be sure the chosen location has a floor or counter strong enough to support the total weight of the unit. Reinforce the floor or counter if necessary to provide for maximum loading. For the most efficient operation, be sure to provide good air circulation inside and out.

The outline dimensional drawing for the unit is shown below in Figure 1.

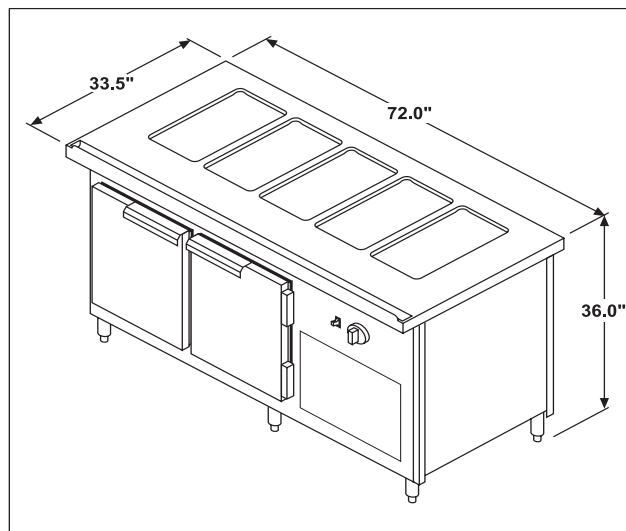

Figure 1
72" Refrigerated Base (RB 72)

Inside Unit

Provide adequate space along the front, back and sides taking care to not block airflow to the fans.

Outside Unit

Be sure that the unit has access to ample air; avoid hot corners and locations near stoves and ovens.

Leveling

Be sure that the units are placed on a firm, flat surface/floor. Check for cracks in flooring or tile and avoid these areas if possible. If necessary place support pads, properly rated for the weight of the unit, to "bridge" uneven or cracked flooring. Level unit accordingly.

Stabilizing

Use the leg adjustments to insure that the unit is solid to the floor surface at all six contact points. Insure that the unit does not "rock" when pressure is applied to the top corners.

Electrical Connection

The RB 72 is available as a 120VAC, 60 Hz or as a 220VAC, 50 Hz dependent on model. All electrical connections should be performed by a certified electrician and should comply with local electrical codes for your municipality.

WARNING

REFER TO THE AMPERAGE DATA LIST IN THE SPECIFICATIONS OR THE SERIAL TAG DATA AND YOUR LOCAL CODE OR THE NATIONAL ELECTRICAL CODE TO BE SURE UNIT IS CONNECTED TO THE PROPER POWER SOURCE. A PROTECTED CIRCUIT OF THE CORRECT VOLTAGE AND AMPERAGE MUST BE RUN FOR CONNECTION OF THE SUPPLY CORD OR PERMANENT CONNECTION TO THE UNIT. THE POWER MUST BE TURNED OFF AND DISCONNECTED WHENEVER PERFORMING MAINTENANCE OR REPAIR FUNCTIONS.

MAINTENANCE

Stainless Steel Care and Cleaning

Stainless steel contains 70-80% iron, which will rust. It also contains 12-30% chromium, which forms an invisible passive film over the steel surface and acts as a shield against corrosion. As long as the protective film remains intact, the metal will not corrode. However, if the film is broken or contaminated, outside elements can begin to breakdown the steel and begin to form rust or discoloration. To prevent rust and discoloration on stainless steel, several important steps need to be taken.

CAUTION: Never use steel wool pads or wire brushes or scrapers. Avoid cleaning solutions that contain alkaline or chloride.



Use alkaline based or non-chloride cleaning solutions. Anything containing chloride will damage the protective film on stainless steel. Chlorides are found in household and industrial cleaners and also in hard water and salts. If a chloride or alkaline cleaner has been used, rinse repeatedly and dry thoroughly.

Always use only soft cloths or plastic scouring pads. For routine cleaning, use warm soapy water. For stubborn stains use a non-abrasive cleanser. For heavy grease use a degreaser. For best results, rub with the grain of the steel.

Pitting and cracking are early signs of stainless steel breakdown. But special stainless steel cleaners can restore and preserve the protective film. If signs of breakdown appear, thoroughly clean and dry all surfaces. Begin regular application of a high quality stainless steel cleaner according to the manufacturer's instructions. Again, always rub with the grain of the steel for best results.

CAUTION: Never use an acid-based cleanser! Be sure to clean all food products from any stainless surface. Many food products contain acid, which can deteriorate the finish. Common foods include tomatoes, peppers and other vegetables.



WARNING

THE POWER MUST BE TURNED OFF AND DISCONNECTED AT ALL TIMES DURING MAINTENANCE OR REPAIR FUNCTIONS.

PREVENTIVE MAINTENANCE

Cleaning the Condenser Coil

Failure to maintain a clean condenser coil can initially cause high temperatures and excessive run times. Continuous operation with dirty or clogged condenser coils can result in compressor failure. Neglecting the condenser coil cleaning procedures will void all warranties and repair or replacement costs associated with the compressor.

CAUTION: To clean the condenser, never use a high-pressure water wash, which can damage electrical components located at or near the condenser coil.

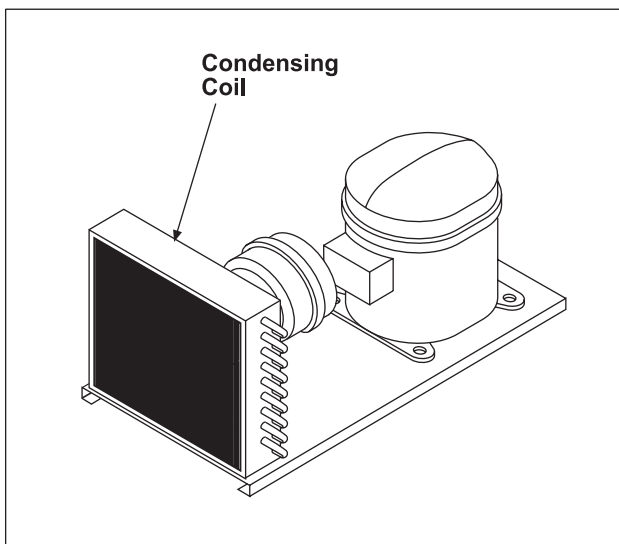

Figure 2
Location of Condensing Coil

The condenser coil is located and accessed at the front of the unit (see Figure 2). The condenser coil requires regular cleaning and should be done every 60 days. However, if large amounts of dust and grease accumulate sooner, clean the condenser coil every 30 days.

For light dust, use a soft, non-wire brush. For heavier dust, use a vacuum or blow with compressed air.

For heavy grease, use a degreasing agent made specifically for condenser coils on refrigeration units. Spray the degreasing agent on the coil and then blow with compressed air. Never wash with high-pressure water, which can damage the electrical components located at or near the condenser coil.

Door Gasket Maintenance

Door gaskets require regular cleaning to prevent mold and mildew build up and to maintain elasticity for proper seal function. Warm soapy water is adequate for cleaning the gasket. Avoid using full strength cleaning products, which can cause the gasket to become brittle and result in improper seal function. Never scrape or clean the gasket with sharp tools or knives which can tear the gasket.

Drain Maintenance – Base

Located at the rear of each unit is a drain hose, which removes the condensation from the evaporator coil and deposits it into a drain pan for evaporation (see Figure 3).

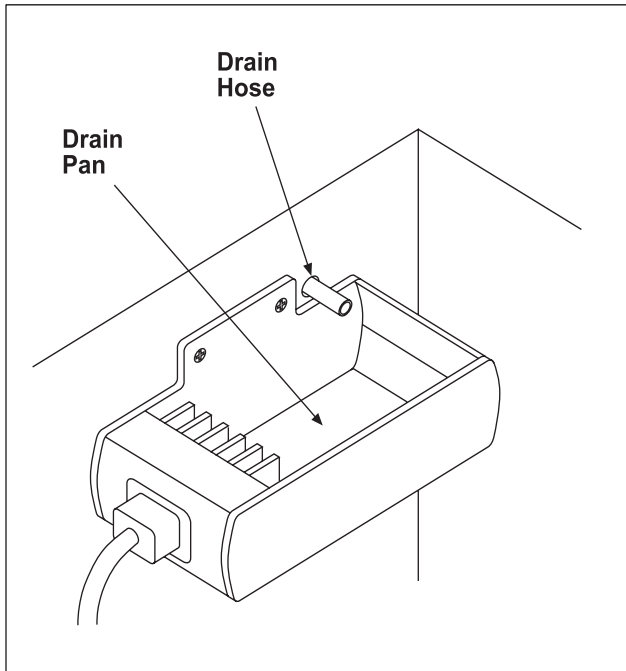

Figure 3
Location of Drain Hose and Drain Pan

If excessive water accumulates inside the unit, check to see that the drain hose is connected from the evaporator housing to the drain pan. If water accumulates underneath the unit, check to see that the drain hose is located above the drain pan.

A level unit is essential for proper drainage. Be sure to provide a level surface below the unit, especially if the floor is not level. Keep the drain pan free from dirt, dust and debris to prevent water from backing up and overflowing from the drain pan onto the floor.

PARTS REPLACEMENT

Thermostat Replacement

General

The thermostat is located inside the cooling compartment and is accessible through the doors.

1. Disconnect unit from power source.
2. Remove shelves.
3. Remove evaporator control box cover, fan, and thermostat assembly.
4. Tag and disconnect thermostat wiring.
5. Remove thermostat probe from evaporator coil.
6. Remove knob, thermostat, and mounting screws.
7. Remove thermostat from control box.
8. Install replacement thermostat, knob, and mounting screws.

NOTE: Do not kink thermostat probe.

NOTE: To ensure proper operation, place 8" of thermostat probe into evaporator coil.

9. Install thermostat probe in evaporator coil.
10. Using tags, connect thermostat wiring.
11. Install evaporator control box cover, fan, and thermostat assembly.
12. Install shelves.
13. Connect unit to power source and test unit.

Evaporator Fan Replacement

General

The evaporator fan is located and accessed inside the cooling compartment and is removed as an assembly from the back panel.

1. Disconnect evaporator fan wiring from power source.
2. Remove shelves.
3. Remove evaporator control box cover, fan, and thermostat assembly.
4. Tag and disconnect wiring.
5. Remove evaporator fan and fan vent mounting hardware.
6. Remove evaporator fan.
7. Install replacement evaporator fan and fan vent mounting hardware.
8. Using tags, connect evaporator fan wiring.
9. Install evaporator control box cover, fan, and thermostat assembly.
10. Install shelves.
11. Connect unit to power source and test unit.

Refrigeration System Replacement

General

The refrigeration system assembly is located in the far right lower compartment behind the filter cover.

1. Disconnect unit from power source.
2. Remove filter cover.
3. Using a refrigeration-charging unit, evacuate refrigerant from the system according to Duke Manufacturing Service Bulletin Number 26.
4. Remove expansion valve from refrigeration assembly.
5. Remove refrigeration assembly mounting hardware.
6. Tag and disconnect wiring at junction box.
7. Slide the refrigeration system assembly out through the front of the unit.
8. Install replacement refrigeration assembly onto slide bars.
9. Slide in refrigeration system assembly to original position.
10. Install refrigeration system assembly mounting hardware.
11. Install expansion valve and evaporator tubing to refrigeration system assembly.
12. Using tags, connect wiring at junction box.
13. Connect unit to power source.
14. Charge system according to Duke Manufacturing Service Bulletin Number 26.
15. Install filter cover.

Door and Hinge Replacement

General

The door and hinge can be replaced.

1. With the door closed, remove the sheet metal cover from the door side of the hinge.
2. While supporting the door, remove three mounting screws and spacer from the unit side of the hinge.
3. Repeat the above procedure on the remaining hinge.
4. Remove the door.
5. Remove three screws and spacer from the door side of the hinges. Remove the hinges.
6. Insert hinges on the door and secure with three screws and spacer.
7. Position the door with hinges on the unit for installation. Secure with three screws and spacer in each hinge.
8. Install sheet metal covers over the door side of the hinges.

Door Gasket Replacement

General

The door gasket has a retaining panel.

1. Remove gasket door panel and mounting screws.
2. Remove gasket and door panel.
3. Position new gasket and panel on door.
4. Secure with mounting screws. Tighten screws evenly around door panel.

Recharging Refrigeration System

General

To analyze the performance of a refrigeration system, temperature readings are recorded and converted to pressure readings using a standard pressure/temperature chart.

When it is necessary to service a factory sealed refrigeration system and return it to its properly sealed condition, strictly adhere to the following approved procedure.

Tools

- Standard hand and refrigeration tools
- Refrigerant Type: R-134A, 4.5 ounces

Charging Procedure

NOTE: Prior to refrigeration system service, special care must be taken during the evacuation process to remove air, moisture and other non-condensables from the system. Duke Manufacturing recommends the following triple evacuation method. Failure to follow this procedure may result in poor refrigeration system performance.

1. Evacuate system to 1500 microns
2. Break vacuum to 2 psig with dry nitrogen. If dry nitrogen is unavailable, use same type of refrigerant as used in system.
3. Evacuate system to 1500 microns.
4. Break vacuum to 2 PSIG with dry nitrogen. If dry nitrogen is unavailable, use same type of refrigerant as used in system.
5. Evacuate system to 500 microns.

The system is now ready to receive refrigerant charge according to information on data plate.

CAUTION: Never use oxygen or acetylene in place of dry nitrogen or refrigerant for leak testing. A violent explosion may result, causing property damage, personal injury or death. When using nitrogen to pressure test, always use a pressure regulator. Failure to do so will result in extremely high pressure of the compressor or other system components and result in property damage, personal injury and death.



NOTE: Prior to repair, ensure there is enough process hose (approximately 12") present to complete the repair using the above procedure. If not, install a new process hose before repair sequence.

1. Install a temporary access valve on the high and low side of process hoses as close to factory crimps as possible.
2. Use temporary valves to perform repair. Duke Manufacturing will not reimburse the cost of permanently installed valves.
3. After completing repair, evacuate system using the triple evacuation method described in Duke Manufacturing Service Bulletin Number 26.
4. After completing proper evacuation method, recharge system, using proper refrigerant according to information on data plate.
5. Continue crimping process hose just below temporary valve and again 2" below crimp.
6. With crimp tool in place, remove temporary valve.
7. Braze shut end of process hose.
8. Allow to cool for about 5 minutes.
9. Remove crimp tool.
10. Check brazed end for leaks.

Heater Thermostat Replacement

General

The heater thermostat is located on the far right front of the unit above the filter cover.

1. Disconnect unit from power source.
2. Remove filter cover.
3. Remove thermostat cover, which is mounted directly above the refrigeration system assembly.
4. Tag and disconnect thermostat wiring.
5. In upper heated compartment, remove thermostat probe cover.
6. Carefully remove thermostat probe.

7. Tag and disconnect warning lamp at thermostat.
8. Remove thermostat knob.
9. Remove thermostat mounting hardware and thermostat.
10. Install replacement thermostat and thermostat mounting hardware.
11. Install thermostat knob.
12. Using tags, connect warning lamp at thermostat.
13. Carefully install thermostat probe.
14. Install thermostat probe cover.
15. Using tags, connect thermostat wiring.
16. Install thermostat.
17. Install filter cover.
18. Connect unit to power source.

Heating Element Replacement

General

The heating element is located in the upper heated compartment.

1. Disconnect unit from power source.
2. Remove filter cover.
3. Remove thermostat cover, which is mounted directly above the refrigeration system assembly.
4. Tag and disconnect heating element wiring.
5. In upper heated compartment, remove heating element mounting hardware and heating element from support brackets.
6. Install replacement heating element and mounting hardware.
7. Using tags, connect heating element wiring.
8. Install thermostat cover.
9. Install filter cover.
10. Connect unit to power source.

TROUBLESHOOTING

SYMPTOM	CAUSE	REMEDY
Cabinet too warm	Unit not plugged in	Plug unit in
	Thermostat set too warm	Set thermostat to a higher number for a colder temperature
	Thermostat switch stuck open in coldest position	Replace thermostat
	Doors not sealing	Adjust doors
	Torn or damaged door gaskets	Replace gaskets
	Evaporator fan not running	Check and repair or replace motor
	Condenser fan motor not running	Check and repair or replace motor
	Dirty condenser coil or filter	Clean coil or filter
	Refrigerant leak	Find leak, repair and recharge
	Thermostat set too cold	Set thermostat to a lower number for a warmer temperature
Cabinet too cold	Thermostat switch is stuck in the closed position	Replace thermostat
	Drain hose plugged	Clear drain hose
Water in bottom of unit	Drain hose loose or disconnected from drain pan	Tighten or connect drain hose



Duke Manufacturing Company

**2305 N. Broadway
St. Louis, MO 63102
Phone: 314-231-1130
Toll Free: 1-800-735-3853
Fax: 314-231-5074
www.dukemfg.com**