

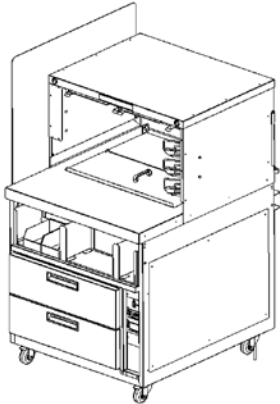

Your Solutions Partner

Illustrated Parts List

SANDWICH PRODUCTION STATION



32" COOK STATION

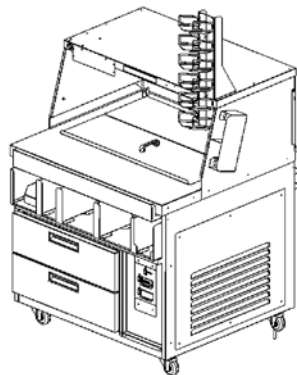

38" ASSEMBLY STATION

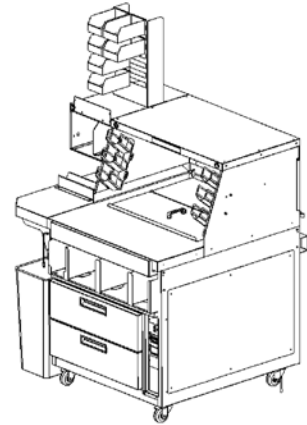

32" ASSEMBLY STATION

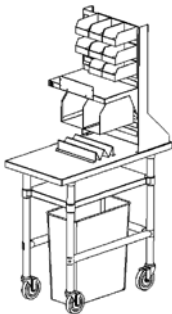

18" EXPEDITE CART

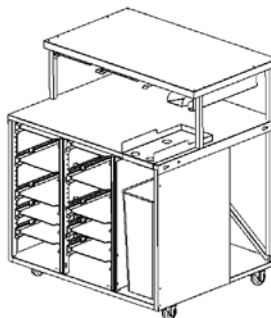

40" TOAST STATION

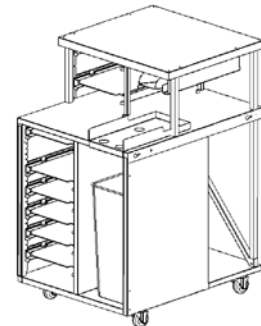

27" TOAST STATION

*This manual is Copyright © 2019 Duke Manufacturing Co. All rights reserved.
Reproduction without written permission is prohibited. Duke is a registered
trademark of the Duke Manufacturing Co.*

Duke Manufacturing Co.

2305 N. Broadway
St. Louis, MO 63102
Phone: 314-231-1130
Toll Free: 1-800-735-3853
Fax: 314-231-5074
www.dukemfg.com

TABLE OF CONTENTS

32" COOK STATION.....	4
Figure: PL-1 32" Cook Station	4
Table: PL-1 32" Cook Station	5
Figure: PL-2 32" Cook Station	6
Table: PL-2 32" Cook Station	7
32" COOK STATION WITH "KOOL" SYSTEM	8
Figure: PL-3 32" Cook Station with "Kool" System	8
Table: PL-3 32" Cook Station with "Kool" System	9
Figure: PL-4 32" Cook Station with "Kool" System	12
Table: PL-4 32" Cook Station with "Kool" System	13
38" ASSEMBLY STATION	14
Figure: PL-5 38" Assembly Station	14
Table: PL-5 38" Assembly Station	15
Figure: PL-6 38" Assembly Station	16
Table: PL-6 38" Assembly Station	17
38" ASSEMBLY STATION WITH "KOOL" SYSTEM	18
Figure: PL-7 38" Assembly Station with "Kool" System	18
Table: PL-7 38" Assembly Station with "Kool" System	19
Figure: PL-8 38" Assembly Station with "Kool" System (cont.)	22
Table: PL-8 38" Assembly Station with "Kool" System (cont.)	23
32" ASSEMBLY STATION	24
Figure: PL-9 32" Assembly Station	24
Table: PL-9 32" Assembly Station	25
Figure: PL-10 32" Assembly Station (Cont.)	26
Table: PL-10 32" Assembly Station (Cont.)	27
32" ASSEMBLY STATION side shelf kit.....	28
Figure: PL-11 32" Assembly Station Side Shelf Kit.....	28
Table: PL-11 32" Assembly Station Side Shelf Kit.....	29
32" ASSEMBLY STATION WITH "KOOL" SYSTEM	30
Figure: PL-12 32" Assembly Station with "Kool" System	30
Table: PL-12 32" Assembly Station with "Kool" System	31
Figure: PL-13 32" Assembly Station with "Kool" System (cont.)	34
Table: PL-13 32" Assembly Station with "Kool" System (cont.)	35
40" TOAST STATION	36
Figure: PL-14 40" Toast Station	36
Table: PL-14 40" Toast Station	37
27" TOAST STATION WITH RIGHT TO LEFT PRODUCT FLOW	38
Figure: PL-15 27" Toast Station with Right to Left Product Flow	38
Table: PL-15 27" Toast Station with Right to Left Product Flow	39
18" EXPEDITE TABLE	40
Figure: PL-16 18" Expedite Table	40
Table: PL-16 18" Expedite Table	41
SANDWICH PRODUCTION STATION FLOW CHART AND SPECS	42
SANDWICH PRODUCTION STATION - "KOOL" SYSTEM - FLOW CHART AND SPECS	43
WIRING DIAGRAM – Sandwich Production Station	44
WIRING DIAGRAM – Sandwich Production Station WITH "KOOL" SYSTEM	45

How to Determine Manufacture Date from Duke Equipment Serial Numbers

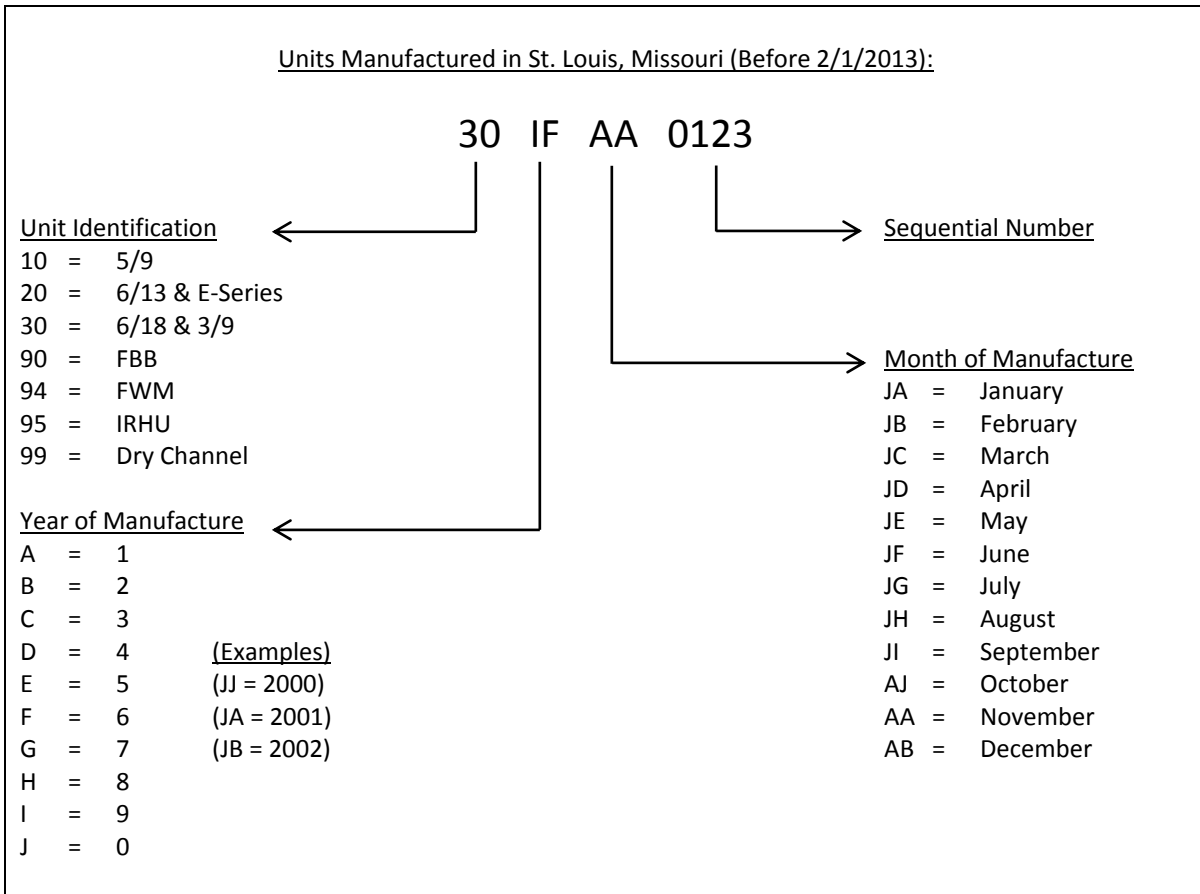
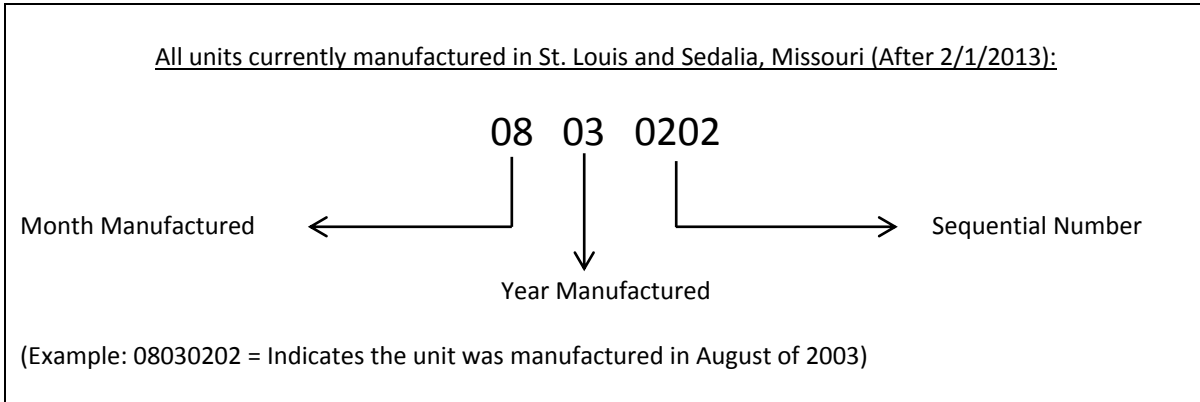

32" COOK STATION

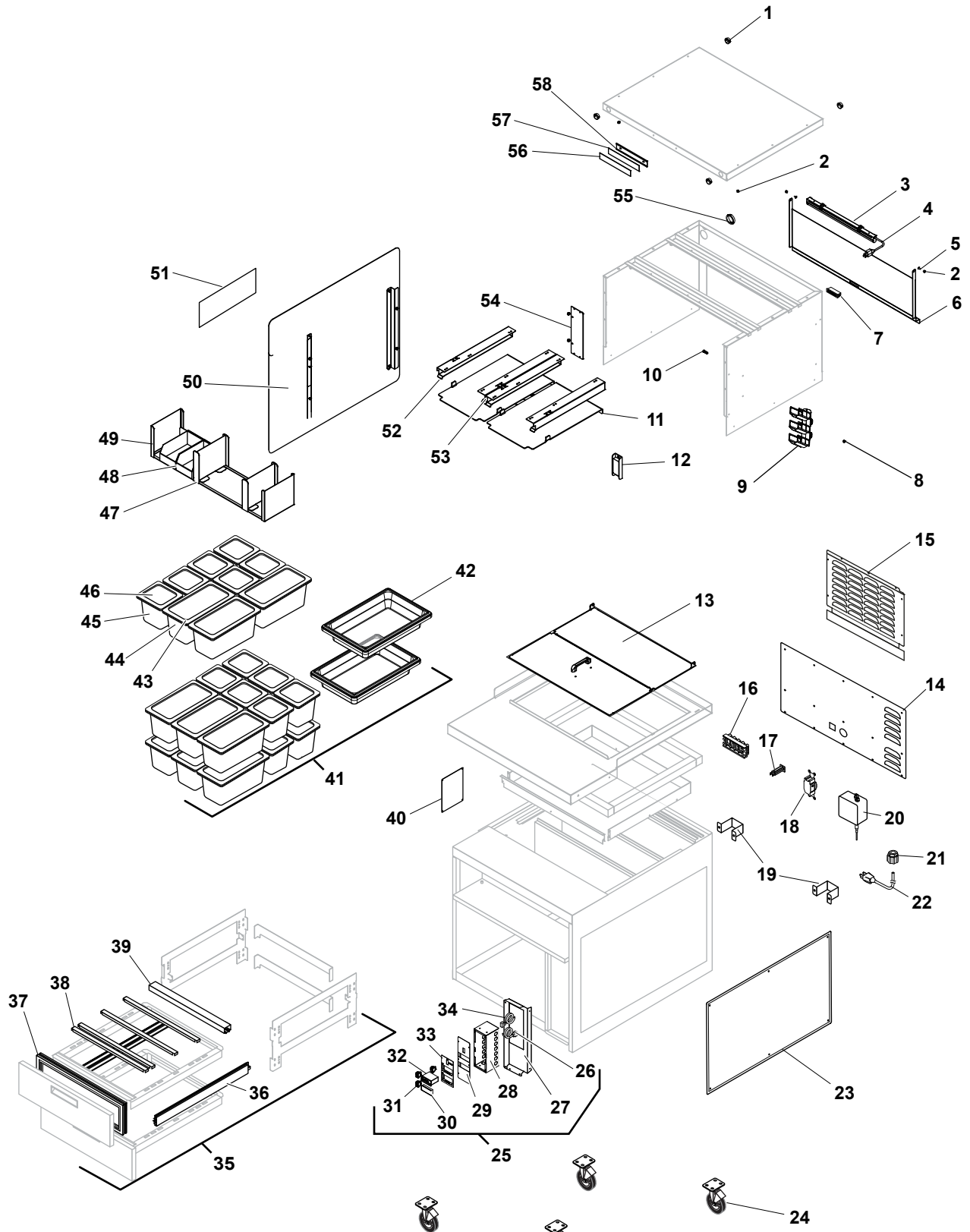

Figure: PL-1 32" Cook Station

32" COOK STATION

Item	Part No.	Description	Qty
1	214459	HEYCO BUSHING 1" HEY2140, BUSHING SNAP 1"	4
2	213063	NUT, 10-24 NYLON INSERT Z	10
3	225890	LED, 17.375" LIGHT, W/ 2 MAGNETIC MOUNTING CLIPS AND 1 SPEC TOOL	1
4	225891	CORD, LED 72" POWER, FOR 3L/LED 181CM AWG 18 SVT WHITE	1
5	213028	SCREW, 10-24 x 3/8" PTHMS S/S	2
6	DD060015	32" REAR WINDOW COVER	1
7	57100	CATCH,MAGNETIC 52-10-201-10 ALSO USED HUSSMANN 0348389	1
8	213040	NUT,10-24 HEX CAP NICKEL PLATED	4
9	DD990097	BOTTLE HOLDER, 3 BOTTLE	1
10	213390	BOLT, CARRIAGE 10-24 x 1/2" SS MACHINE	4
11	DD990090	PAN COVER ACRYLIC W/ STOPS	2
12	215318	MAGNET, W/STRIKE	1
13	520265	32" NIGHT COVER ASSY	1
14	DD990196	32" UTILITY CHASE COVER	1
15	DD990171	32" PLATE COVER, REAR CHASE, LOUVERED	1
16	120001	BLOCK, TERMINAL 4 POLE	1
17	212309	CIRCUIT BREAKER COLD - 2 AMP	1
18	212177	RECPT, ELEC 5-15 SINGLE HBL5261	1
19	DD990068	REAR BUMPER BRACKET	2
20	226044	SWITCH, PRESSURE (Emerson Copeland #099024, MODEL PS1-X3K)	1
21	212117	STRAIN RELIEF, W/NUT	1
22	222100	CORD,W/PLUG NEMA 5-20	1
23	DD990069	ACCESS PANEL	1
24	215002	CASTER, 3" DIA SWIVEL W/BRAKE 4" LOAD HEIGHT	4
25	520195	32" CONTROL ASSY	1
26	226050	HARNESS, MALE END WIRE	1
27	DD990085	CONTROL PANEL MOUNT	1
28	DD990087	CONTROL PANEL BOX	1
29	DD990086	CONTROL PANEL PLATE	1
30	520285	KIT, DIGITAL THERMOSTAT & CONTROL MODULE, SET FOR 32" CP UNIT (216827)	1
31	212288	SWITCH,LIGHTED	3
32	520284	KIT, THERMOSTAT, ELREHA DIGITAL DISPLAY, SET FOR 32" CP UNIT (216837)	1
33	224971	LABEL, CP CONTROL 6.875 x 3.625 FOR 32" CP UNIT	1
34	226051	HARNESS, WIRING FEMALE END	1
35	2500047	DRAWER SLIDE FRAME ASSY UTR	1
36	211602	SLIDE, DRAWER FR790CNS7926	2
37	211601	GASKET, MAGNETIC DOOR UTC	2
38	E021049	CHANNEL ADAPTER BAR UTR HORZ (<i>Units manufactured after 1/25/2017, Qty = 8</i>)	6 or 8
39	2500048	MULLION ASSY HORZ UTR 1PC SLIDE FRAME	1
40	DD990121	PLATE COVER FOR END PANEL W/ FAN ACCESS	1
41	DD-32-COOK-PAN-KIT	COOK STATION PAN KIT	1
42	227515	FOOD BOX, 18" x 12" x 3.5" #12183CW135	2
43	217503	PAN, 1/3 6" DEEP, 36CW, CLEAR	9
44	217504	LID, PAN 1/3 30CWCH135, CLEAR W/HANDLE	9
45	217505	PAN, 1/6 - 6" DEEP 66CW CLEAR	18
46	217506	LID, PAN 1/6 60CWCH135, CLEAR W/HANDLE	18
47	520261	COOK STATION WRAPPER HOLDER ASSY	1
48	228300	BIN, PLASTIC CLEAR 4.125 x 7.375 x 3	2
49	DD990130	BOX HOLDER PAN DOUBLE	1
50	520239	HEAT SHIELD ASSY	1
	DD-EXT-HEAT-SHIELD-KIT	EXTENDED HEAT SHIELD KIT FOR COOK STATION	1
51	229052	LABEL, HEAT SHIELD (Attaches to 520239)	1
52	520274	KIT, TOP PAN SUPPORT ANGLE LEFT (DD180091)	2
53	520275	KIT, TOP PAN SUPPORT ANGLE RIGHT (DD180092)	2
54	520268	KIT, BUMP BAR PLATE (DD180039 & 213178)	1
55	214236	GROMMET,ROUND 1.75" DIA BL #20609073-A030I	1
56	224969	POLYCARBONATE, CP LABEL COVER CL. .022X8 x .1281	1
57	224970	POLYCARBONATE, CP LABEL COVER WHITE- .015X8 x .1281	1
58	DD180098	COLD PAN LABEL HOLDER	1

Table: PL-1 32" Cook Station

32" COOK STATION (CONT.)

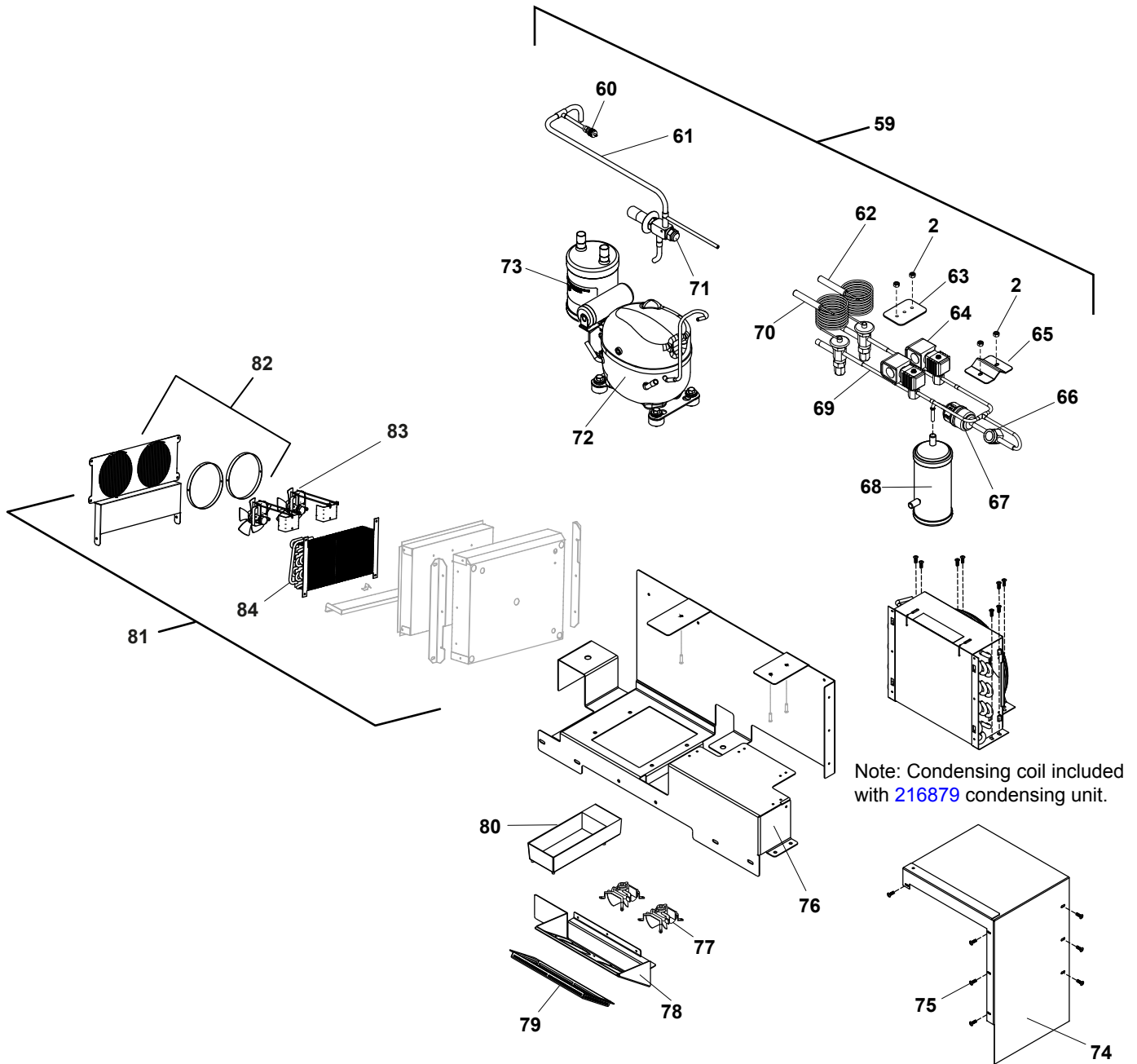

Figure: PL-2 32" Cook Station

32" COOK STATION (CONT.)

Item	Part No.	Description	Qty
59	DD990158	32" COND UNIT ASSY	1
60	216547	VALVE 1/4 SCHRADER	2
61	226062	MANIFOLD, SUCTION LINE ASSY (#071795-02)	1
62	520281	KIT, TXV VALVE, Set for UTR side of 32" Cond. Unit (Ref - 226061, Sporland #Y-1001-FBS-1/8-2)	2
63	DD990147	SQUEEZE PLATE, COPPER TUBING	1
64	216553	SOLENOID, REFRIG W/COIL 120V (Ref - 226061, Sporland #E3S120)	2
65	DD990210	SQUEEZE PLATE, LIQUID LINE	1
66	216415	GLASS,SIGHT STD#7 (Sporland #SA-12S)	1
67	226039	DRYER, FILTER (Sporland #C-033-S-T)	1
68	226052	RECEIVER (Parker #RT306V-TS)	1
69	226061	TXV TUBE ASSEMBLY	1
70	520282	KIT, TXV VALVE, Set for CP Side of 32" Cond. Unit (Ref - 226061, Sporland #Y-1001-FBS-1/8-Z)	2
71	520283	KIT, CPR VALVE, (Ref-226062, Sporland CRO-4-0/75)	1
72	527844	COMPRESSOR, 1/3 HP, 120V 60Hz (Ref-216879)	1
Not Shown	217808	FAN MOTOR (Ref - 216879, Emerson/Copeland #050-0298-01)	1
Not Shown	217809	FAN BLADE (Ref - 216879, Emerson/Copeland #083-0122-00)	1
Not Shown	217908	BRACKET, FAN MOTOR (Ref - 216879, Emerson/Copeland #074-7236-00)	1
Not Shown	217909	GUARD, FAN (Emerson/Copeland #024-0252-00)	1
Not Shown	217813	PROTECTOR (Ref - 216879, Emerson/Copeland #071-0561-16)	1
Not Shown	217843	START CAPACITOR (Ref - 216879, Emerson/Copeland #014-0053-18)	1
Not Shown	217883	RELAY (Ref - 216879, Emerson/Copeland #040-0163-10)	1
Not Shown	217907	CONDENSOR (REF - 216879, Emerson/Copeland #066-0333-03)	1
73	520443	ACCUMULATOR, PARTS KIT	1
74	DD990157	AIR SHROUD 32" CP UNIT	1
75	213032	SCREW, 8 x 1/2 TEK PHIL	15
76	DD990144	BRACKET CONDENSING UNIT 32" DD	1
77	216772	FAN, 120V 50/60HZ, 115 CFM (Bay Motor Products #5A145-160A)	2
78	DD180093	DUAL FAN CHANNEL 32	1
79	DD180071	FAN COVER CHANNEL	1
80	216608	EVAPORATOR, REFRIG 117V (Component Hardware #T12-5000-2)	1
81	259895	ASSY, MECH UTR	1
82	520291	KIT, UTR FAN COVER (DD990170 & E021057)	1
83	71138	EVAPORATOR FAN MOTOR ASSY (Bay Motor Products #5A145-175P)	2
84	216516	COIL, REFRIG EVAP	1

Table: PL-2 32" Cook Station

32" COOK STATION WITH "KOOL" SYSTEM

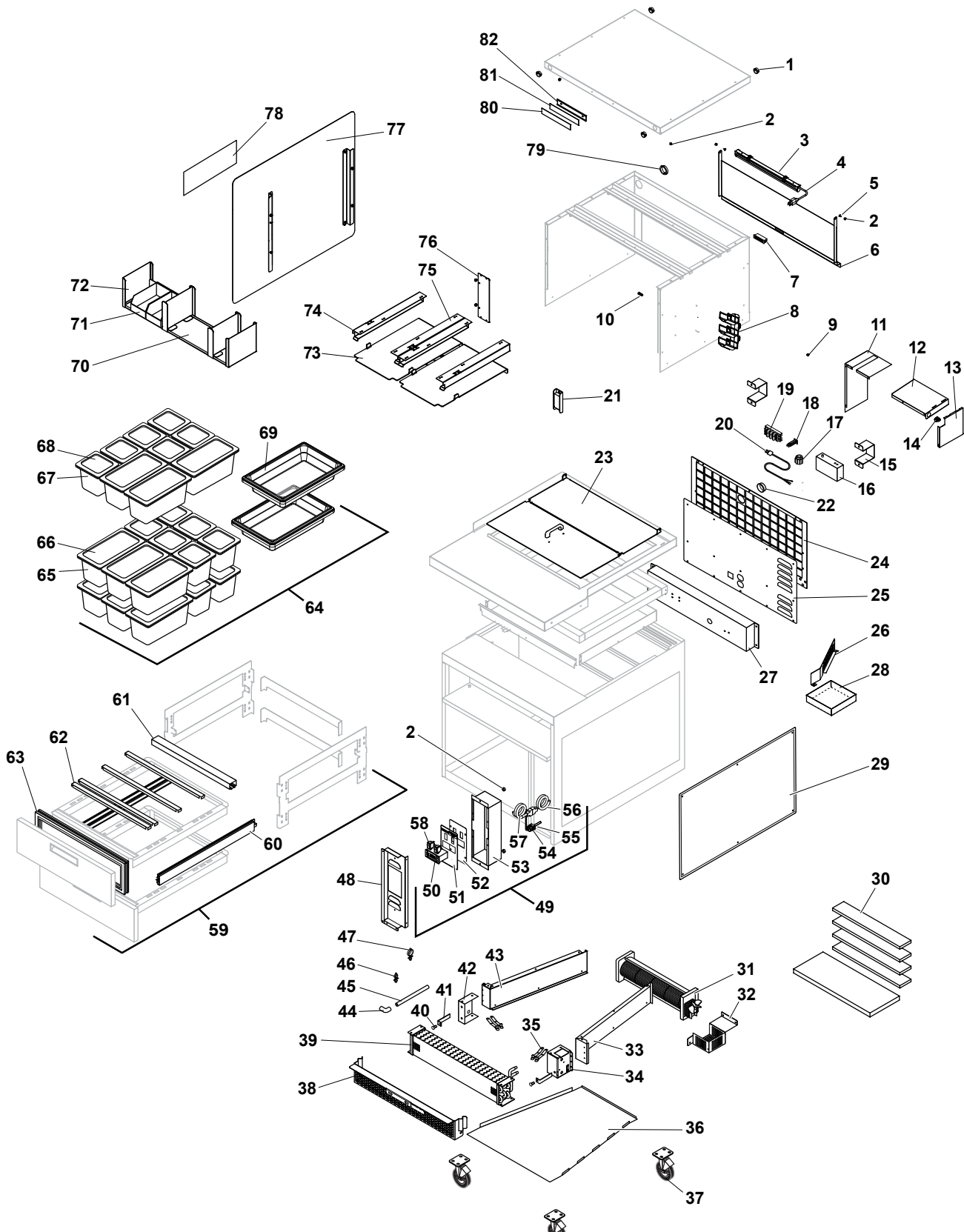

Figure: PL-3 32" Cook Station with "Kool" System

32" COOK STATION WITH "KOOL" SYSTEM

Item	Part No.	Description	Qty
1	214459	HEYCO BUSHING 1" HEY2140, BUSHING SNAP 1"	4
2	213063	NUT, 10-24 NYLON INSERT Z	19
3	225890	LED, 17.375" LIGHT, W/ 2 MAGNETIC MOUNTING CLIPS AND 1 SPEC TOOL	1
4	225891	CORD, LED 72" POWER, FOR 3L/LED 181CM AWG 18 SVT WHITE	1
5	213028	SCREW, 10-24 x 3/8" PTHMS S/S	2
6	DD060015	32" REAR WINDOW COVER	1
7	57100	CATCH,MAGNETIC 52-10-201-10 ALSO USED HUSSMANN 0348389	1
8	DD990097	SHORT BOTTLE HOLDER	1
9	213040	NUT,10-24 HEX CAP NICKEL PLATED MILD STEEL	4
10	213390	BOLT, CARRIAGE 10-24 x 1/2" SS MACHINE	4
11	DD990312	LEFT AIR DEFLECTOR	1
12	DD990333	DEFLECTOR, AIR TOP 32 "KOOL"	1
13	DD990334	DEFLECTOR, AIR SIDE 32 "KOOL"	1
14	212023	BUSHING,HEYCO SB-875-11	2
15	DD990068	REAR BUMPER BRACKET	2
16	216891	CONTROL PRESSURE	1
17	212117	STRAIN RELIEF,W/ 1/2" LOCK NUT SHC1022CR	1
18	212309	CIRCUIT BREAKER COLD - 2 AMP #TYCO #3-1393250-2	1
19	120001	BLOCK,TERMINAL 4 POLE	1
20	212170	CORD,W/PLUG 5-15 14/3 6 FT 15A 1Ph	1
21	215318	MAGNET, W/STRIKE	1
22	214236	GROMMET,ROUND 1.75"DIA BL #20609073-A030I	1
23	520265	32" NIGHT COVER ASSY	1
24	DD990287	REAR COVER	1
25	RT990020	32" UTILITY CHASE COVER W/DUPLEX OUTLET	1
26	DD990294	COND. PAN SUPPORT	1
27	DD990289	32 REAR CHASE	1
28	254547	PAN CONDENSATE COLLECTION SW UTR	1
29	DD990293	ACCESS PANEL 32	1
30	520305	KIT, FILTER REPLACEMENT (4- 224940 Filters)	1
31	600540	KIT, TANGENTIAL MOTOR REPLACEMENT (<i>Ref-226960</i>)	1
32	DD990285	MOTOR GUARD	1
33	DD990282	32 LEFT DUCT END	1
34	DD990264	END COIL MOUNTING	1
35	225400	CLIP, SPRING VALCO #F-162	4
36	DD990284	DUCT BOTTOM	1
37	215002	CASTER, 3" DIA SWIVEL W/BRAKE 4" LOAD HEIGHT	4
38	DD990329	COIL COVER GRILLE	1
39	226790	COIL, CONDENSER 20x4 .375 TUBE	1
40	213360	SCREW,10-24x3/8 PTMS SS W/NYLOK PATCH	2
41	DD990330	RETAINER CLIP	2
42	DD990265	COIL END BRACKET SHORT (514788 Nutsert must be Factory Installed)	1
43	DD990283	32 RIGHT DUCT END	1
44	224408	ELBOW, 3/8" PLASTIC PUSH FIT	1
45	DD990318	UTR DRAIN TUBE	1

Table: PL-3 32" Cook Station with "Kool" System

32" COOK STATION WITH "KOOL" SYSTEM (CONT.)

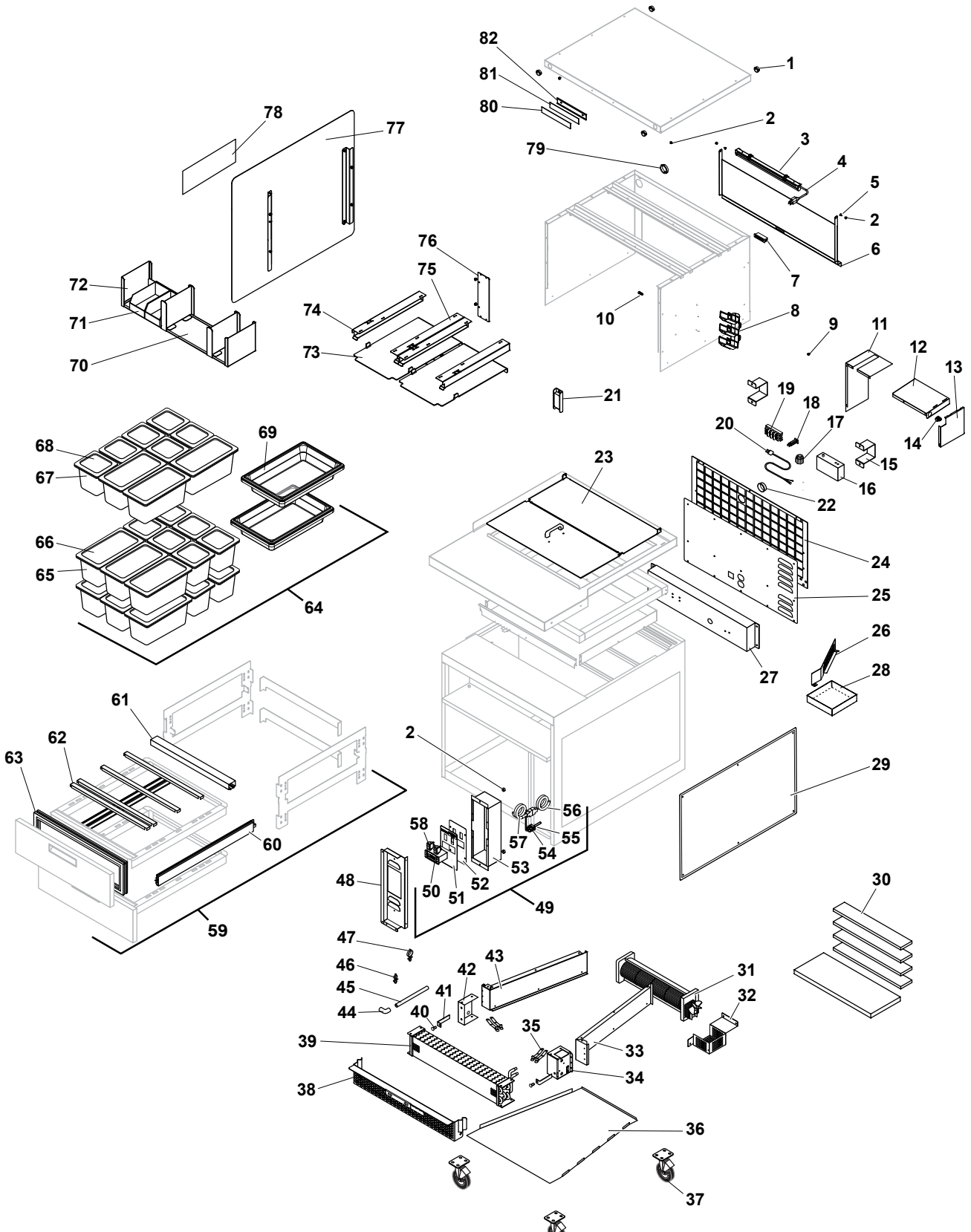

Figure: PL-3 32" Cook Station with "Kool" System

32" COOK STATION WITH "KOOL" SYSTEM (CONT.)

Item	Part No.	Description	Qty
46	222232	STAND OFF, WIRE PANDUIT WS35-25-C	1
47	222233	STAND OFF, WIRE PANDUIT WS75-25-C	1
48	DD990327	32" CONTROL MOUNT	1
49	520303	CONTROLS	1
50	224409-KK	CUSTOM PROGRAMMED	1
51	224973	LABEL, CP CONTROL 3.75X7 FOR FRONT BREATHING CP UNIT	1
52	DD990292	CP CONTROL FACE PLATE	1
53	DD990326	CP CONTROL BOX	1
54	222101	BUSHING,HEYCO 1280 STRAIN RELIEF	1
55	216812	PROBE, 1.8" NTC 1.5 METER WIRE	3
56	226059	WIRE HARNESS 2nd GEN	1
57	226058	WIRE HARNESS 2nd GEN	1
58	212288	SWITCH LIGHTED SUBWAY	2
59	2500047	DRAWER SLIDE FRAME ASSY UTR	2
60	211602	SLIDE, DRAWER FR790CNS7926	2
61	2500048	MULLION ASSY HORZ UTR 1PC SLIDE FRAME	1
62	E021049	CHANNEL ADAPTER BAR UTR HORZ <i>(Units manufactured after 1/25/2017, Qty = 8)</i>	6 or 8
63	211601	GASKET, MAGNETIC DOOR UTC	2
64	DD-32-COOK-PAN-KIT	COOK STATION PAN KIT	1
65	217503	PAN, 1/3 6" DEEP, 36CW, CLEAR	9
66	217504	LID, PAN 1/3 30CWCH135, CLEAR W/HANDLE	9
67	217505	PAN, 1/6 - 6" DEEP 66CW CLEAR	18
68	217506	LID, PAN 1/6 60CWCH135, CLEAR W/HANDLE	18
69	227515	FOOD BOX, 18" x 12" x 3.5" #12183CW135	2
70	520261	COOK STATION WRAPPER HOLDER ASSY	1
71	228300	BIN, PLASTIC CLEAR 4.125 x 7.375 x 3	2
72	DD990130	BOX HOLDER PAN DOUBLE	1
73	DD990090	Pan Cover Acrylic w/ stops	2
74	520274	KIT, TOP PAN SUPPORT ANGLE LEFT (DD180091)	2
75	520275	KIT, TOP PAN SUPPORT ANGLE RIGHT (DD180092)	2
76	520268	KIT, BUMP BAR PLATE (DD180039 & 213178)	1
77	520239	HEAT SHIELD ASSY	1
	DD-EXT-HEAT-SHIELD-KIT	EXTENDED HEAT SHIELD KIT FOR COOK STATION	1
78	229052	LABEL, HEAT SHIELD (Attaches to 520239)	1
79	214236	GROMMET, ROUND 1.75" DIA BL #20609073-A030I	1
80	224969	POLYCARBONATE, CP LABEL COVER CL. .022X8 x .1281	1
81	224970	POLYCARBONATE, CP LABEL COVER WHITE- .015X8 x .1281	1
82	DD180098	COLD PAN LABEL HOLDER	1
Not Shown	212022	RECPT,ELEC 5-15 DUPLEX	1

Table: PL-3 32" Cook Station with "Kool" System

32" COOK STATION WITH "KOOL" SYSTEM (CONT.)

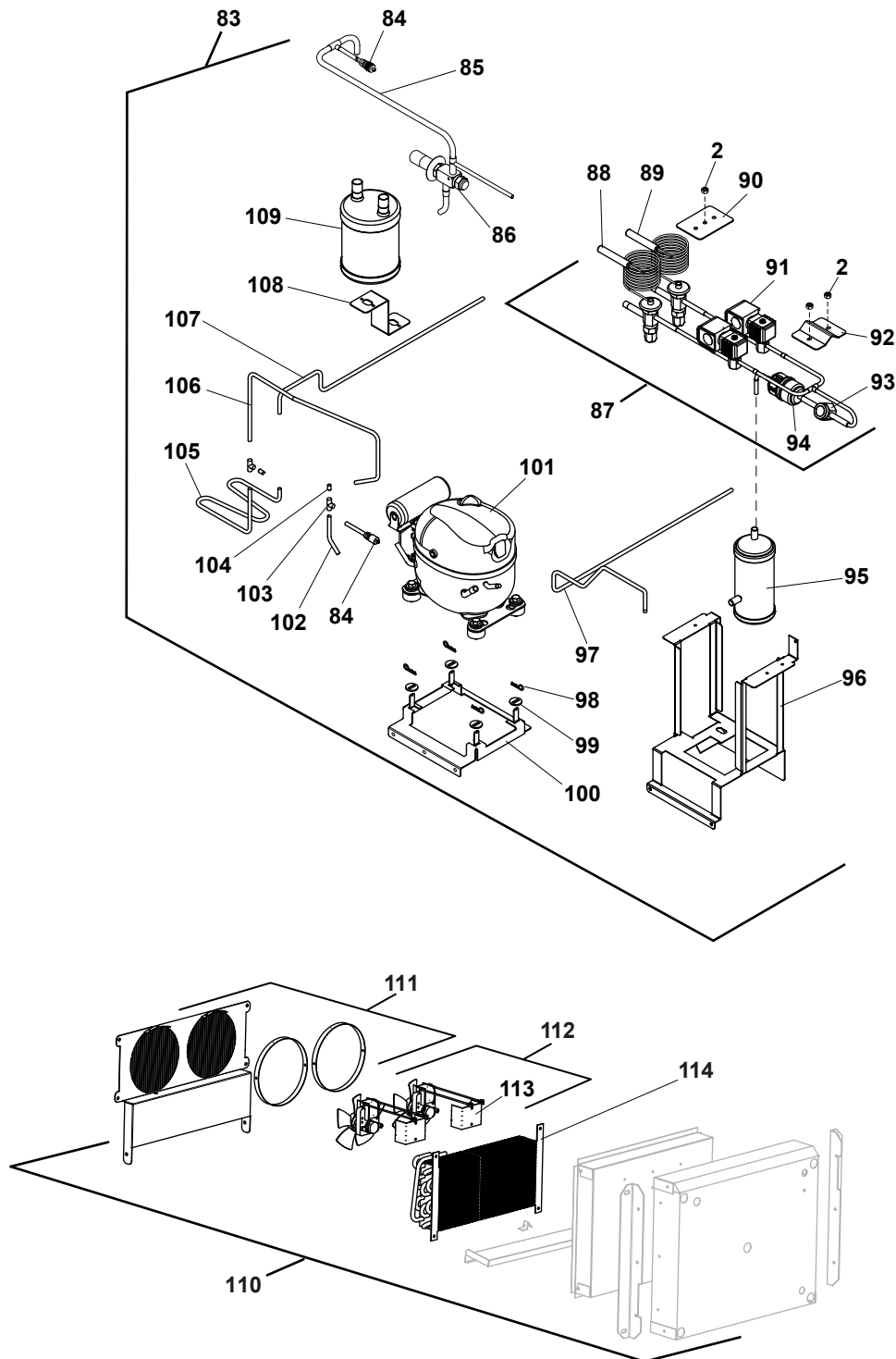

Figure: PL-4 32" Cook Station with "Kool" System

32" COOK STATION WITH "KOOL" SYSTEM (CONT.)

Item	Part No.	Description	Qty
83	520304	32" COND UNIT ASSY	1
84	216547	Valve 1/4" Schrader	2
85	226062	MANIFOLD, SUCTION LINE ASSY (#071795-02)	1
86	520283	CPR VALVE KIT, SET UP FOR 32" CONDENSING UNIT (Ref-226062)	1
87	226061	MANIFOLD, LIQUID LINE ASSB. #071795-01	1
88	520282	KIT, TXV VALVE, Set for CP Side of 32" Cond. Unit (Ref - 226061 , Sporland #Y-1001-FBS-1/8-Z)	2
89	520281	KIT, TXV VALVE, Set for UTR side of 32" Cond. Unit (Ref - 226061 , Sporland #Y-1001-FBS-1/8-2)	2
90	DD990147	SQUEEZE PLATE, COPPER TUBING	1
91	216553	SOLENOID, REFRIG W/COIL 120V (Ref - 226061 , Sporland #E3S120)	2
92	DD990210	SQUEEZE PLATE, LIQUID LINE	1
93	216415	GLASS,SIGHT STD#7 (Sporland #SA-12S)	1
94	226039	DRYER, FILTER (Sporland #C-033-S-T)	1
95	226052	RECEIVER, Parker P# RT306V-TS	1
96	DD990280	Suction Line Support-32 (3-115174 Pem Studs, Must Be Installed. Ref-520304)	1
97	DD990317K	HOT GAS CONDENSOR TUBE	1
98	213217	CLIP, HAIRPIN # 213	4
99	290047	WASHER COMPRESSOR FROST TOP	4
100	DD990281	32 COMPRESSOR SUPPORT	1
101	527844	Compressor, 1/3HP 120V 60HZ (Ref-226841 & 216879)	1
102	DD100017K	PRESSURE REGULATOR TUBE	1
103	216512	TEE, 1/4x1/4x1/4 COPPER SWEAT	2
104	223587	BUSHING, BRAZED .094ID X 0.25 OD X .375 LONG, 110 COPPER	2
105	DD990299K	EVAP TUBE	1
106	DD990315K	CONDENSATE EVAP TUBE	1
107	DD990316K	HOT GAS CONDENSER TUBE	1
108	DD990325	ACCUMULATOR MOUNT	1
109	520443	ACCUMULATOR, PARTS KIT	1
110	259895	ASSY, MECH UTR	1
111	520291	KIT, UTR FAN COVER (DD990170 & E021057)	1
112	71138	EVAPORATOR FAN MOTOR ASSY (Bay Motor Products #5A145-175P)	2
113	E990074	MOTOR MOUNT UTR	2
114	216516	COIL, REFRIG EVAP	1

Table: PL-4 32" Cook Station with "Kool" System

38" ASSEMBLY STATION

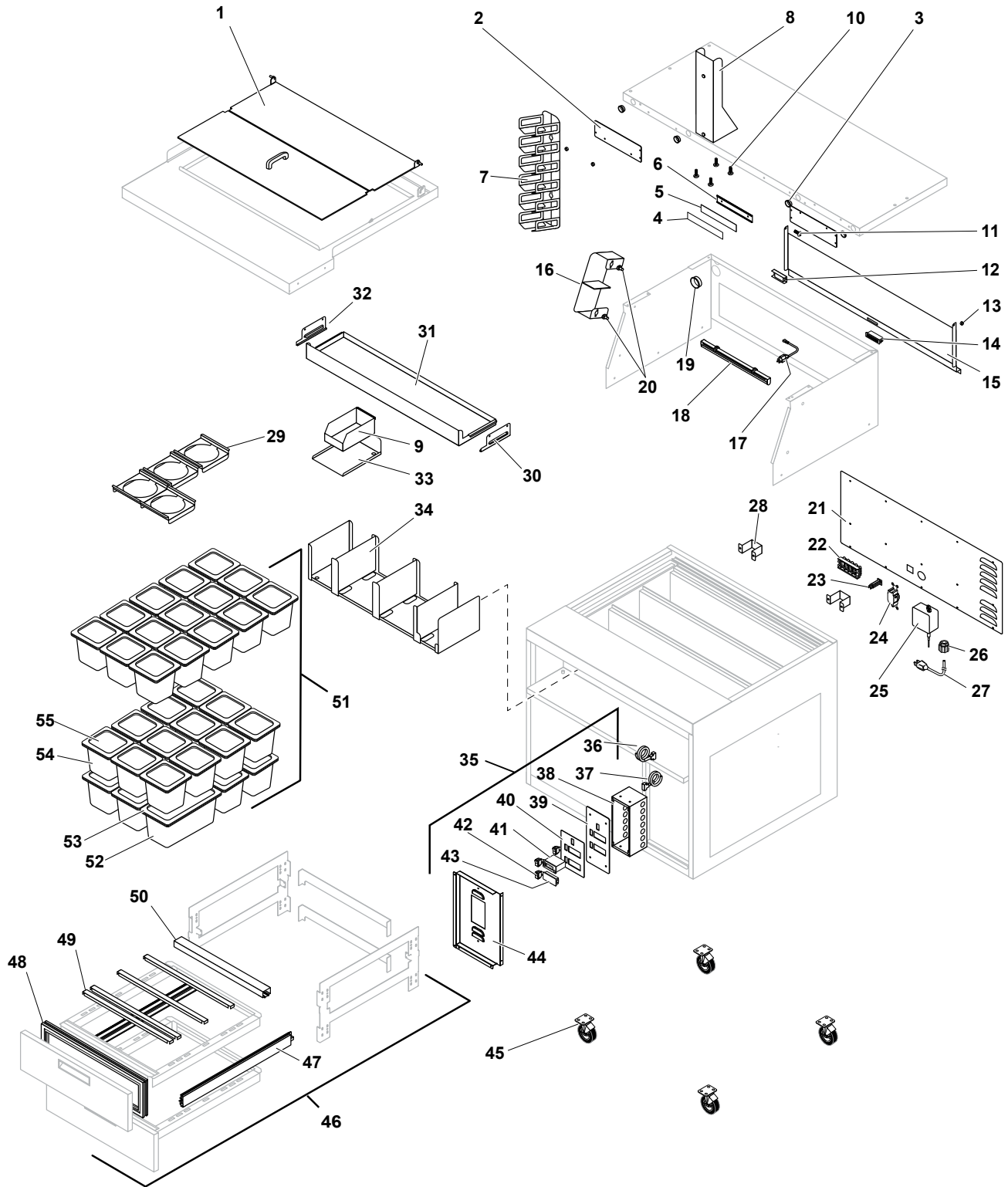

Figure: PL-5 38" Assembly Station

38" ASSEMBLY STATION

Item	Part No.	Description	Qty
1	520266	38" NIGHT COVER ASM	1
2	DD990039	BUMP BAR PLATE	2
3	214459	HEYCO BUSHING 1" HEY2140, BUSHING SNAP 1"	4
4	224969	POLYCARBONATE, CP LABEL COVER CL .022 x 8 x .1281"	1
5	224970	POLYCARBONATE, CP LABEL BACKER	1
6	DD180098	COLD PAN LABEL HOLDER	1
7	DD990078	BOTTLE HOLDER 6	1
8	DD990079	BOTTLE HOLDER BRACKET	1
9	228300	BIN, PLASTIC CLEAR 4.125 x 7.375 x 3	1
10	213027	SCREW, 10-24x1/2" PTHMS S/S	4
11	213028	SCREW, 10-24 x 3/8" PTHMS SS	2
12	215318	MAGNET, W/STRIKE	1
13	213063	NUT, 10-24 NYLON INSERT Z	A/R
14	57100	CATCH, MAGNETIC 52-10-201-10	1
15	DD060017	38" REAR CLEANING WINDOW COVER	1
16	520270	KIT, HASH BROWN BAG HOLDER (DD990132 & DD990081)	1
17	225891	CORD, LED 72" POWER, FOR 3L/LED 181CM AWG 18 SVT WHITE	1
18	225890	LED, 17.375" LIGHT, W/ 2 MAGNETIC MOUNTING CLIPS & 1 SPEC TOOL	1
19	214236	GROMMET, ROUND 1.75" DIA BL #20609073-A030I	1
20	213390	BOLT, CARRIAGE, 10-24 x 1/2" SS MACHINE	6
21	DD990197	UTILITY CHASE COVER	1
22	120001	BLOCK, TERMINAL 4 POLE	1
23	212309	CIRCUIT BREAKER COLD - 2 AMP	1
24	212117	STRAIN RELIEF, W/NUT	1
25	226044	SWITCH, PRESSURE	1
26	212177	RECPT, ELEC 5-15 SINGLE HBL5261	1
27	222100	CORD, W/PLUG NEMA 5-20	1
28	DD990068	REAR BUMPER BRACKET	2
29	DD990117	BUTTER HOLDER	4
30	E021054	BRACKET CRUMB TRAY RIGHT	1
31	E021056	CRUMB TRAY 38" REMOVABLE	1
32	E021053	BRACKET CRUMB TRAY LEFT	1
33	DD990131	BOX HOLDER PAN SINGLE	1
34	520264	38" ASSY STATION WRAPPER HOLDER	1
35	520197	38" CONTROL ASM	1
36	226050	HARNESS, MALE END WIRE	1
37	226051	HARNESS, WIRING FEMALE END	1
38	DD990055	CP CONTROL BOX	1
39	DD990083	CONTROL PANEL PLATE	1
40	224972	LABEL, CP CONTROL 6.875 x 5.313 FOR 38" CP UNIT	1
41	520286	KIT, THERMOSTAT, ELREHA DIGITAL DISPLAY, SET UP FOR 38" CP UNIT (216837)	1
42	212288	SWITCH, LIGHTED	3
43	520287	KIT, DIGITAL THERMOSTAT & CONTROL MODULE, SET UP FOR 38" CP UNIT (216827)	1
44	DD990082	CONTROL PANEL MOUNT	1
45	215002	CASTER, 3" DIA SWIVEL W/BRAKE 4" LOAD HEIGHT	4
46	2500047	DRAWER SLIDE FRAME ASSY UTR	1
47	211602	SLIDE, DRAWER FR790CNS7926	2
48	E021049	CHANNEL ADAPTER BAR UTR HORZ (<i>Units manufactured after 1/25/2017, Qty = 8</i>)	6 or 8
49	211601	GASKET, MAGNETIC DOOR UTC	2
50	2500048	MULLION ASSY HORZ UTR 1PC SLIDE FRAME	1
51	DD-38-ASSEMBLE-PAN-KIT	COOK STATION PAN KIT	1
52	217503	PAN, 1/3 - 6" DEEP 36CW, CLEAR	3
53	217504	LID, PAN 1/3 30CWCH135, CLEAR W/HANDLE	3
54	217505	PAN, 1/6 - 6" DEEP 66CW, CLEAR	33
55	217506	LID, PAN 1/6 66CWCH135, CLEAR W/HANDLE	33
Not Shown	213353	SCREW, 6-32 x 7/16" PHFHMS S PHILIPS FLAT HEAD	A/R
Not Shown	213406	NUT, KEPS 6-32 HEX SS	A/R

Table: PL-5 38" Assembly Station

38" ASSEMBLY STATION (CONT.)

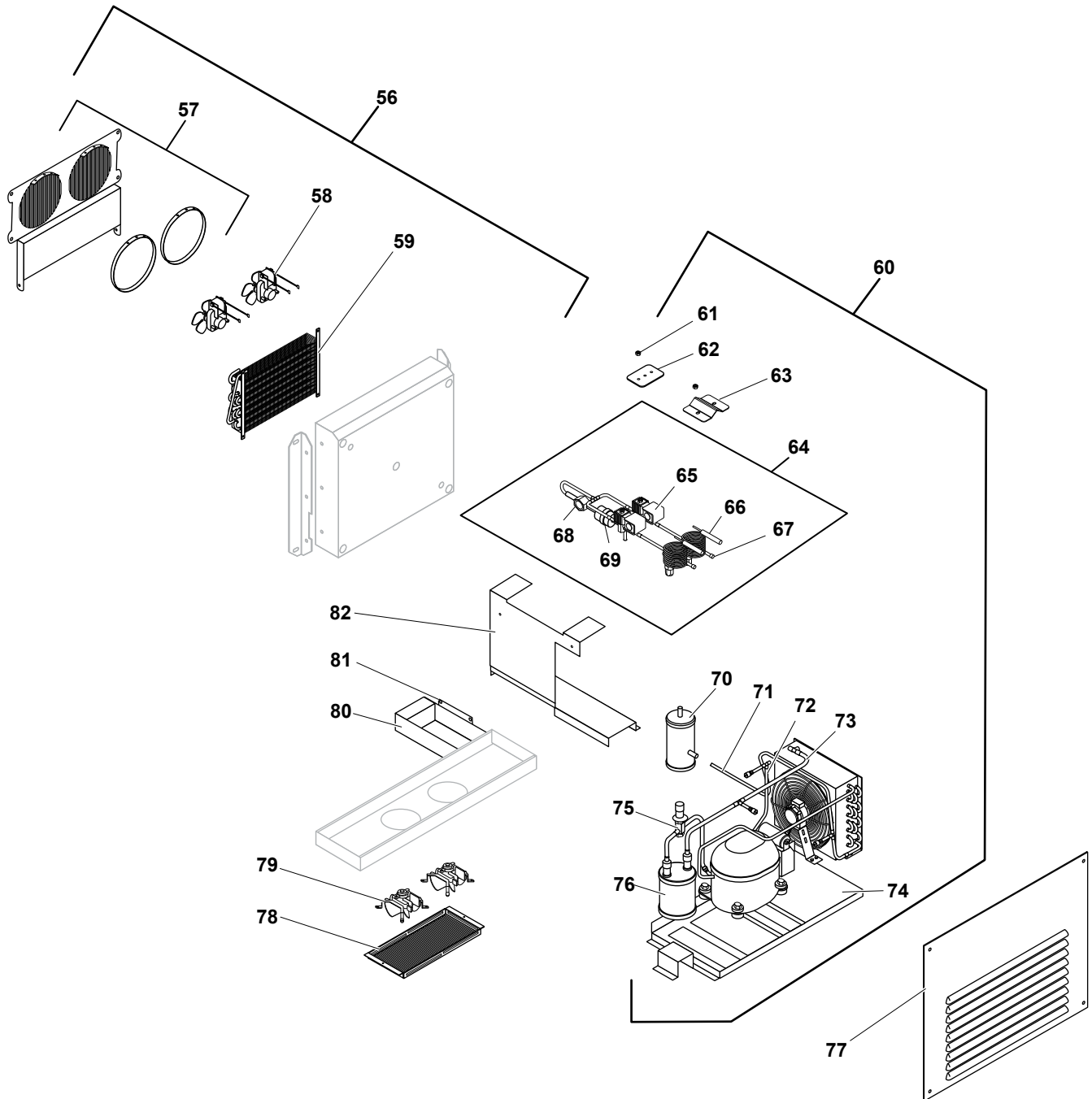

Figure: PL-6 38" Assembly Station

38" ASSEMBLY STATION (CONT.)

Item	Part No.	Description	Qty
56	259895	ASSY, MECH UTR	1
57	520291	KIT, UTR FAN COVER (DD990170 & E021057)	1
58	71138	EVAPORATOR FAN MOTOR ASSY (Bay Motor Products #5A145-175P)	2
59	216516	COIL, REFRIG EVAP	1
60	DD990167	38" COND UNIT ASM	1
61	213063	NUT NYLON INSERT 10-24	4
62	DD990147	SQUEEZE PLATE, COPPER TUBING	1
63	DD990210	SQUEEZE PLATE, LIQUID LINE	1
64	226061	TXV TUBE ASSEMBLY	1
65	216553	SOLENOID, REFRIG. W/COIL 120V (Ref - 226061 , Sporland #E3S120)	2
66	520278	KIT, TXV VALVE, SET FOR CP SIDE OF 38" CONDENSING UNIT (Ref - 226061 , Sporland #Y-1001-FBS-1/8-Z)	1
67	520279	KIT, TXV VALVE, SET FOR UTR SIDE OF 38" CONDENSING UNIT (Ref - 226061 , Sporland #Y-1001-FBS-1/8-Z)	1
68	216415	SIGHT GLASS, STD, #7 (Ref- 226061 , Sporland #SA-12S)	1
69	226039	DRIER, FILTER (Sporland #C-033-S-T)	1
70	226052	RECIEVER (Parker #RT306V-TS)	1
71	DD990165	ASSY, CONDENSING COIL TO RECEIVER LIQUID LINE	1
72	DD990164	ASSY, PRESSURE LINE	1
73	DD990166K	ASSEMBLY, UTR & TRI-CHANNEL TO ACCUMULATOR SUCTION LINE	1
Not Shown	217808	FAN MOTOR (Ref - 216879 , Emerson/Copeland #050-0298-01)	1
Not Shown	217809	FAN BLADE (Ref - 216879 , Emerson/Copeland #083-0122-00)	1
Not Shown	217909	GUARD, FAN (Ref - 216879 , Emerson/Copeland #024-0252-00)	1
Not Shown	217908	BRACKET, FAN MOTOR (Ref - 216879 , Emerson/Copeland #074-7236-00)	1
Not Shown	217813	PROTECTOR (Ref - 216879 , Emerson/Copeland #071-0561-16)	1
Not Shown	217843	START CAPACITOR (Ref - 216879 , Emerson/Copeland #014-0053-18)	1
Not Shown	527844	COMPRESSOR, 1/3 HP, 120V 60Hz (Ref - 216879)	1
Not Shown	217883	RELAY (Ref - 216879 , Emerson/Copeland #040-0163-10)	1
Not Shown	217907	CONDENSOR (REF - 216879 , Emerson/Copeland #066-0333-03)	1
74	DD990168	BRACKET, CASSETTE L-SHAPED 38" UNIT	1
75	520280	KIT, CPR VALVE (Ref - 226063 , Sporland #CRO-4-07/75 3X3 ODF)	1
76	520443	ACCUMULATOR, PARTS KIT	1
77	DD990072	END ACCESS PANEL W/LOUVERS	1
78	DD180071	FAN COVER CHANNEL	1
79	216772	FAN, 120V 50/60HZ,115 CFM	2
80	216608	EVAPORATOR, REFRIG 117V	1
81	216642	BRACKET, WALL MOUNT	1
82	DD990169	CASSETTE REAR 38" UNIT	1

Table: PL-6 38" Assembly Station

38" ASSEMBLY STATION WITH "KOOL" SYSTEM

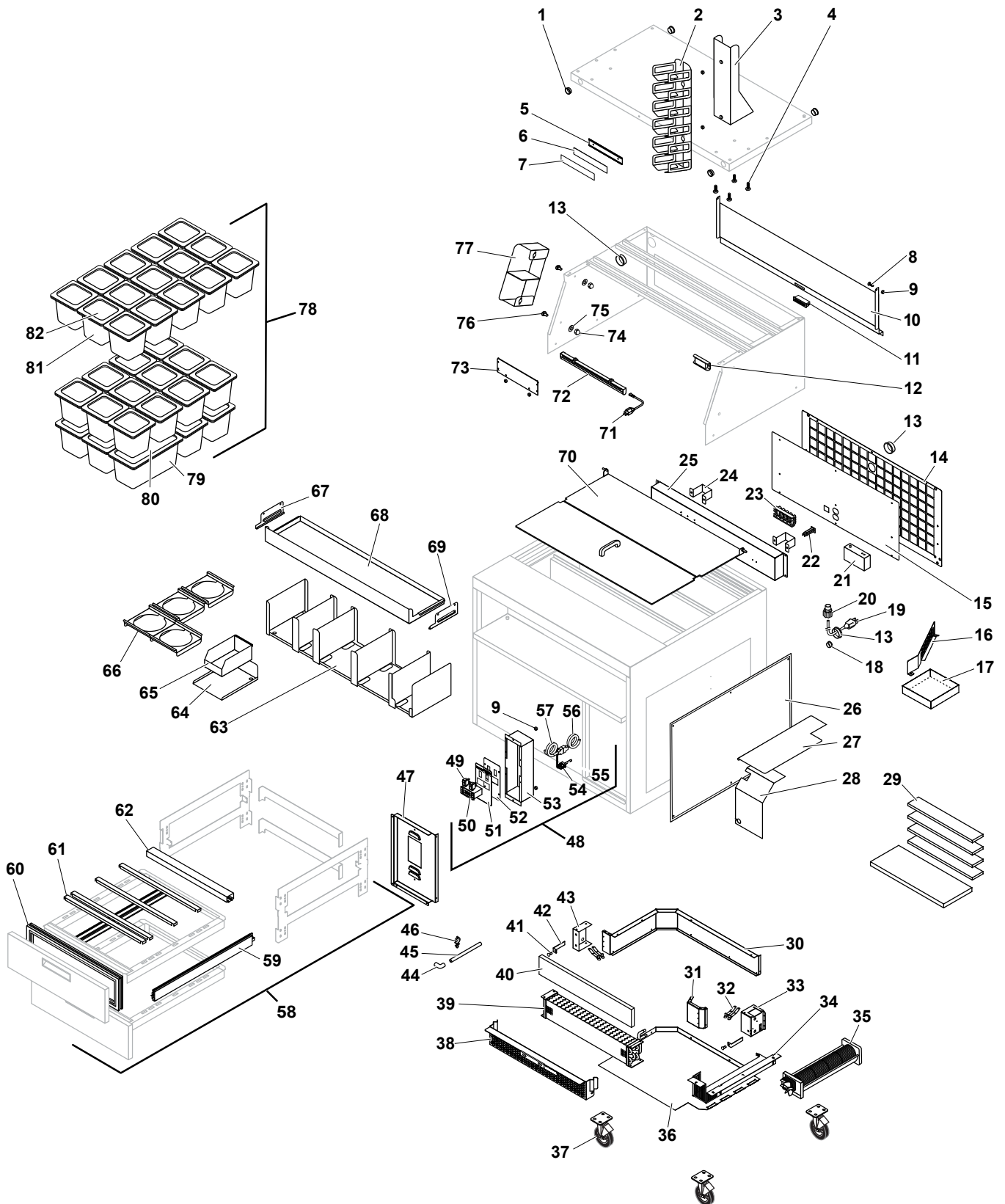

Figure: PL-7 38" Assembly Station with "KOOL" System

38" ASSEMBLY STATION WITH "KOOL" SYSTEM

Item	Part No.	Description	Qty
1	214459	HEYCO BUSHING 1" HEY2140, BUSHING SNAP 1"	4
2	DD990078	BOTTLE HOLDER 6-NO AUDIT REQUIRED	1
3	DD990079	BOTTLE HOLDER BRACKET	1
4	213027	SCREW,10-24x1/2" PTHMS S/S	4
5	DD180098	COLD PAN LABEL HOLDER	1
6	224970	POLYCARBONATE, CP LABEL COVER WHITE	1
7	224969	POLYCARBONATE, CP LABEL COVER	1
8	213028	SCREW,10-24x3/8" PTHMS S/S	2
9	213063	NUT,10-24 NYLON INSERT Z	19
10	DD060017	38" REAR CLEANING WINDOW	1
11	57100	CATCH,MAGNETIC	1
12	215318	MAGNET,#M35-1000 W/STRIKE SUBWAY DOORS MAGNET	1
13	214236	GROMMET,ROUND 1.75"DIA BL #20609073-A030I	3
14	DD990272	REAR COVER 38, PERFORATED	1
15	RT990017	38_RACE_T_UTILITY CHASE	1
16	DD990294	COND. PAN SUPPORT	1
17	254547	PAN CONDENSATE COLLECTION SW UTR	1
18	212023	BUSHING,HEYCO SB-875-11	4
19	212170	CORD,W/PLUG 5-15 14/3 6 FT 15A 1Ph	1
20	212117	STRAIN RELIEF,W/ 1/2" LOCK NUT SHC1022CR	1
21	216891	SWITCH, PRESSURE CONTROL ICE CREAM UNIT	1
22	212309	CIRCUIT BREAKER COLD - 2 AMP	1
23	120001	BLOCK,TERMINAL 4 POLE	1
24	DD990068	REAR BUMPER BRACKET	2
25	DD990278	38 UTILITY CHASE	1
26	DD990257	38 ACCESS PANEL NO LOUVERS	1
27	DD990271	AIR DEFLECTOR TOP	1
28	DD990270	AIR DEFLECTOR BOTTOM	1
29	520305	KIT, FILTER REPLACEMENT (4 - 224940 FILTERS)	1
30	DD990297	DUCT REAR	1
31	DD990295	DUCT TRANSITION	1
32	225400	CLIP, SPRING VALCO #F-162	4
33	DD990264	COIL END BRACKET LONG (514788 Nutsert must be Factory Installed)	1
34	DD990298	MOTOR GUARD MOUNT	1
35	600540	KIT, TANGENTIAL MOTOR REPLACEMENT (Ref- 226960)	1
36	DD990296	DUCT BOTTOM 38	1
37	215002	CASTER,3"DIA SWIVEL W/BRAKE 4" LOAD HEIGHT	4
38	DD990329	COIL COVER GRILLE	1
39	226790	COIL, CONDENSER 20x4 .375 TUBE	1
40	224940	FILTER, FIBERGLASS PAD 4" X 24' X1/2"	1
41	213360	SCREW,10-24x3/8 PTMS SS W/NYLOK PATCH	2
42	DD990330	RETAINER CLIP	2
43	DD990265	COIL END BRACKET SHORT (514788 Nutsert must be Factory Installed)	1

Table: PL-7 38" Assembly Station with "Kool" System

38" ASSEMBLY STATION WITH "KOOL" SYSTEM (CONT.)

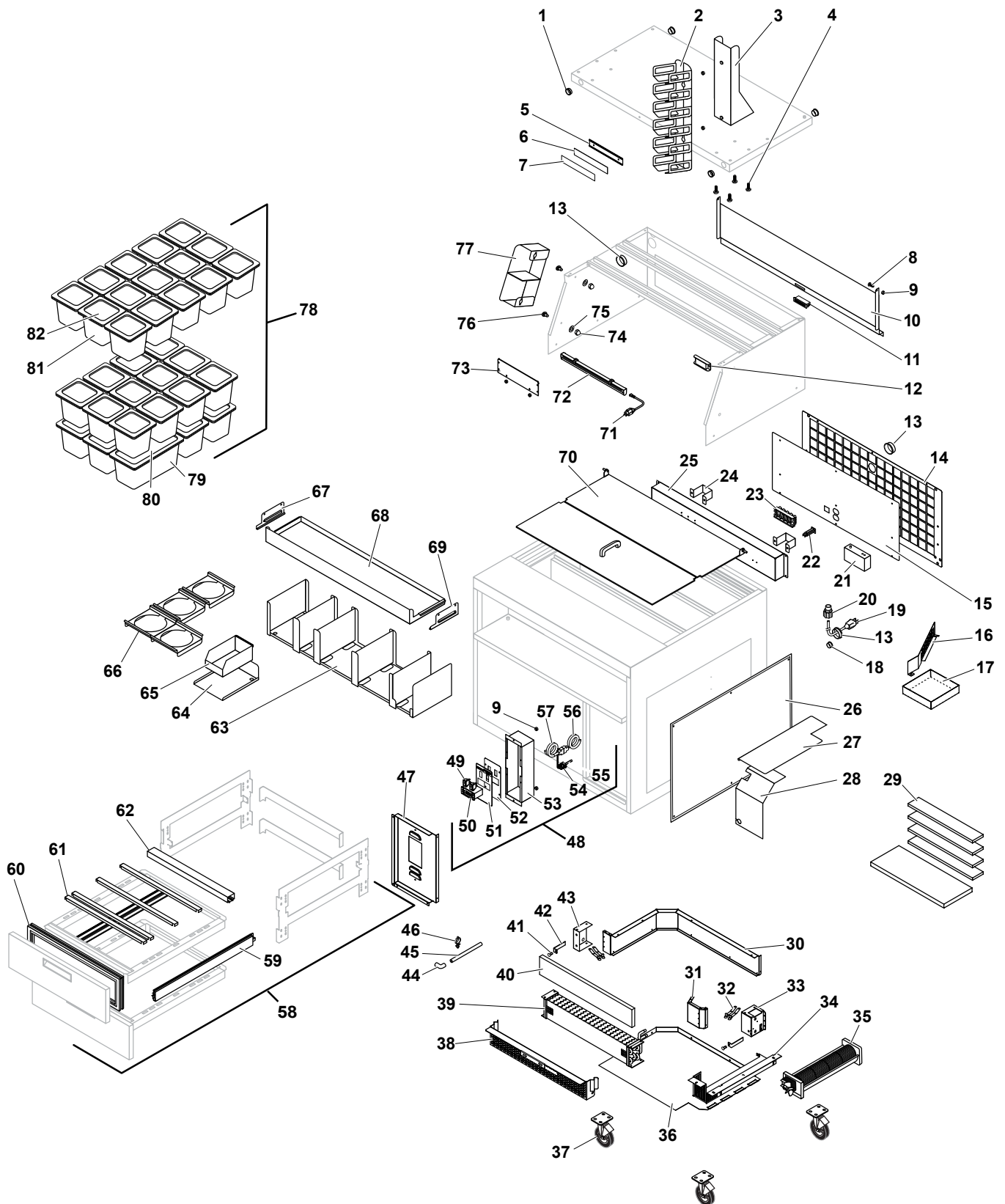

Figure: PL-7 38" Assembly Station with "KOOL" System (cont.)

38" ASSEMBLY STATION WITH "KOOL" SYSTEM (CONT.)

Item	Part No.	Description	Qty
44	224408	ELBOW, 3/8" PLASTIC PUSH FIT	1
45	DD990318	UTR DRAIN TUBE	1
46	222233	STAND OFF, WIRE PANDUIT WS75-25-C	1
47	DD990328	38" CONTROL MOUNT	1
48	520303	DUNKIN CONTROL ASM	1
49	212288	SWITCH,LIGHTED SUBWAY 120	2
50	224409-KK	Custom Programmed Thermostat, Cont. Rev 4 RFM Dixell # XR40CX	1
51	224973	LABEL, CP CONTROL 3.75X7 FOR FRONT BREATHING CP UNIT	1
52	DD990292	32 CONTROL COVER PLATE	1
53	DD990326	CONTROL BOX	1
54	222101	BUSHING,HEYCO 1280 STRAIN RELIEF	1
55	216812	PROBE, 1.8" NTC 1.5 METER WIRE	3
56	226059	HARNESS, WIRING FEMALE END 2nd GEN	1
57	226058	HARNESS, MALE END WIRE 2nd GEN	1
58	2500047	DRAWER SLIDE FRAME ASSY UTR	1
59	211602	SLIDE, DRAWER FR790CNS7926	2
60	211601	GASKET, MAGNETIC DOOR UTC	2
61	E021049	CHANNEL ADAPTER BAR UTR HORZ <i>(Units manufactured after 1/25/2017, Qty = 8)</i>	6 or 8
62	2500048	MULLION ASSY HORZ UTR 1PC SLIDE FRAME	1
63	520264	38" ASY STATION WRAPPER HOLDER ASM	1
64	DD990131	BOX HOLDER PAN SINGLE	1
65	228300	BIN,PLASTIC CLEAR 4.125X7.375X3	1
66	DD990117	BUTTER HOLDER	4
67	E021053	BRACKET CRUMB TRAY LEFT	1
68	E021056	CRUMB TRAY 38" REMOVABLE	1
69	E021054	BRACKET CRUMB TRAY RIGHT	1
70	520266	38" NIGHT COVER ASM	1
71	225891	CORD,LED 72" POWER	1
72	225890	LED, 17.375" LIGHT (W/2 Mag. Mount Clips & 1 Spec Tool)	1
73	520268	BUMP BAR PLATE KIT (DD180039 & 213178)	1
74	213040	NUT,10-24 HEX CAP NICKEL PLATED MILD STEEL	4
75	213055	WASHER,AN960-C10L,18-8 SS	4
76	213390	BOLT,CARRIAGE 10-24X1/2SS MACHINE	6
77	520270	HASHBROWN BAG HOLDER KIT (DD990132 & DD990081)	1
78	DD-38-ASSEMBLE-PAN-KIT	Pan Kit for 38" Assembly Station (217503-217504-217505- 217506)	1
79	217503	Pan,1/3 6" Deep 36CW Clear (Component of Pan Kit)	1
80	217504	Lid, Pan 1/3 30CWCH135, Clear w/Handle (Component of Pan Kit)	1
81	217505	Pan,1/6 6" Deep 66CW Clear (Component of Pan Kit)	1
82	217506	Lid, Pan 1/6 60CWCH135 (Component of Pan Kit)	1
Not Shown	213353	SCREW,6-32X7/16" PHFHMS S PHILIPS FLAT HEAD	4
Not Shown	213406	NUT,KEPS 6-32 HEX SS	4
Not Shown	212022	RECPT,ELEC 5-15 DUPLEX	1

Table: PL-7 38" Assembly Station with "Kool" System (cont.)

38" ASSEMBLY STATION WITH "KOOL" SYSTEM (CONT.)

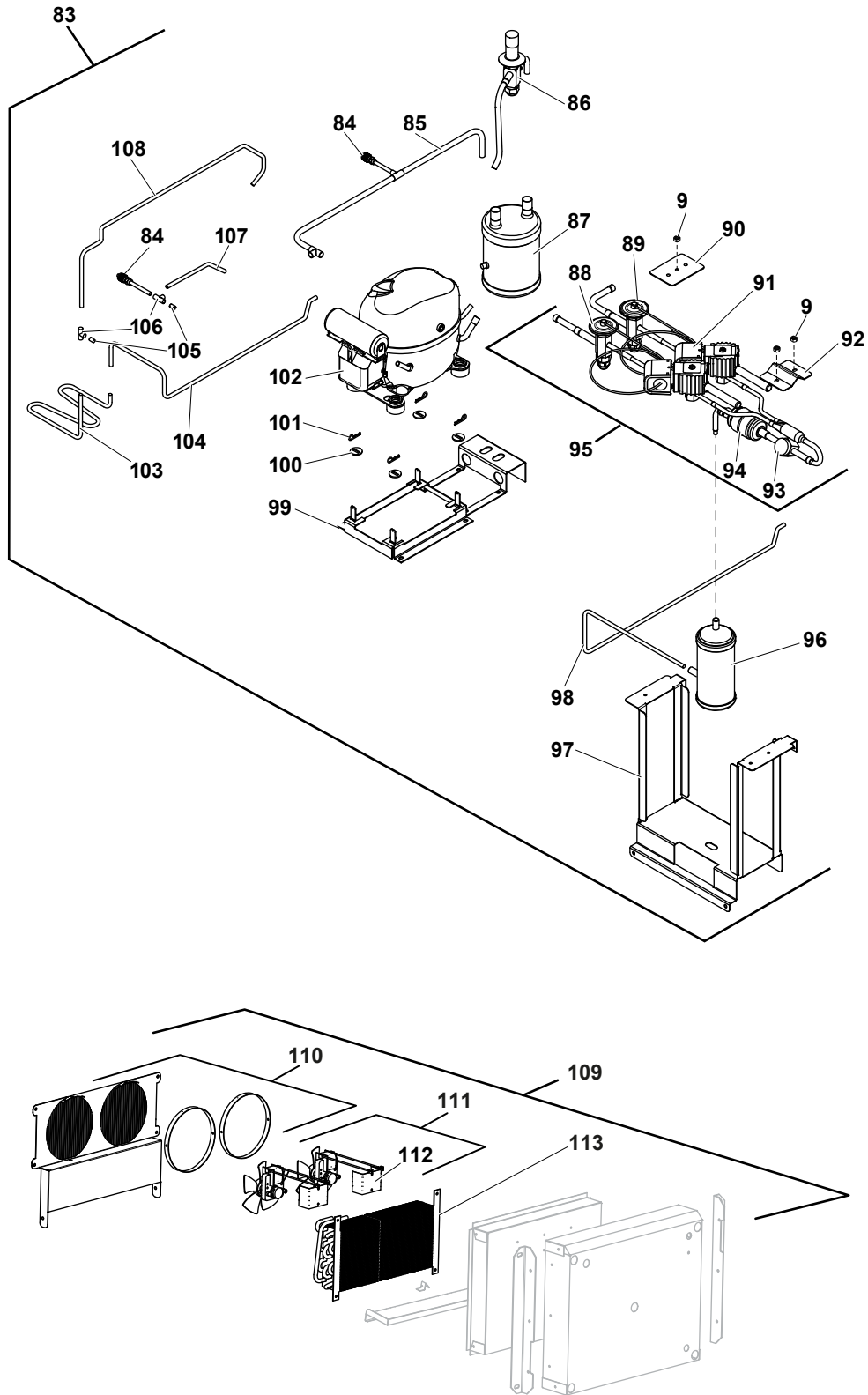

Figure: PL-8 38" Assembly Station with "Kool" System (cont.)

38" ASSEMBLY STATION WITH "KOOL" SYSTEM (CONT.)

Item	Part No.	Description	Qty
83	DD990251	38" COND UNIT ASM 2ND GEN	1
84	216547	VALVE 1/4 SCHRADER #vax-4	2
85	DD990166K	Assembly, UTR & Tri-Channel Tube to Accumulator Suction Line	1
86	226063	ASSY., SUCTION LINE LESS PRESSURE TAP DUNKIN DONUTS	1
87	520443	ACCUMULATOR, PARTS KIT	1
88	520278	"KIT, TXV VALVE, SET FOR CP SIDE OF 38" CONDENSING UNIT	1
89	520279	"KIT, TXV VALVE, SET FOR UTR SIDE OF 38" CONDENSING UNIT	1
90	DD990147	PLATE COPPER TUBING SQUEEZE 32" DD	1
91	216553	SOLENOID, REFRIG. W/COIL 120V (Ref - 226061 , Sporland #E3S120)	2
92	DD990210	SQUEEZE PLATE, LIQUID LINE	1
93	216415	Sight Glass , STD, #7 (Ref- 226061 , Sporland #SA-12S)	1
94	226039	Drier, Filter (Ref- 226061 , Sporland #C-033-S-T)	1
95	226061	MANIFOLD, LIQUID LINE ASSB. #071795-01	1
96	226052	RECEIVER, Parker P# RT306V-TS	1
97	DD990256	Suction Line Support-38 (3 - 115174 Pem Studs, Must Be Installed)	1
98	DD990302K	HOT GAS CONDENSER TUBE	1
99	DD990255	COMPRESSOR BASE PLATE	1
100	290047	WASHER COMPRESSOR FROST TOP	4
101	213217	CLIP, HAIRPIN # 213	4
102	527844	Compresor, 1/3HP 120V 60HZ (Ref-226841 & 216879)	1
103	DD990299K	EVAP TUBE	1
104	DD990300K	HOT GAS CONDENSER TUBE	1
105	223587	BUSHING, BRAZED .094ID X 0.25 OD X .375 LONG, 110 COPPER	2
106	216512	TEE, 1/4x1/4x1/4 COPPER SWEAT	2
107	DD990303K	LOW PRESSURE TUBE	1
108	DD990301K	HIGH PRESSURE TUBE	1
109	259895	ASY, MECH UTR	1
110	520291	UTR FAN COVER KIT (DD990170 & E01057)	1
111	71138	EVAPORATOR FAN MOTOR ASSY 5A145-175P	2
112	E990074	MOTOR MOUNT UTR	2
113	216516	COIL, REFRIG EVAP R-134A	1

Table: PL-8 38" Assembly Station with "Kool" System (cont.)

32" ASSEMBLY STATION

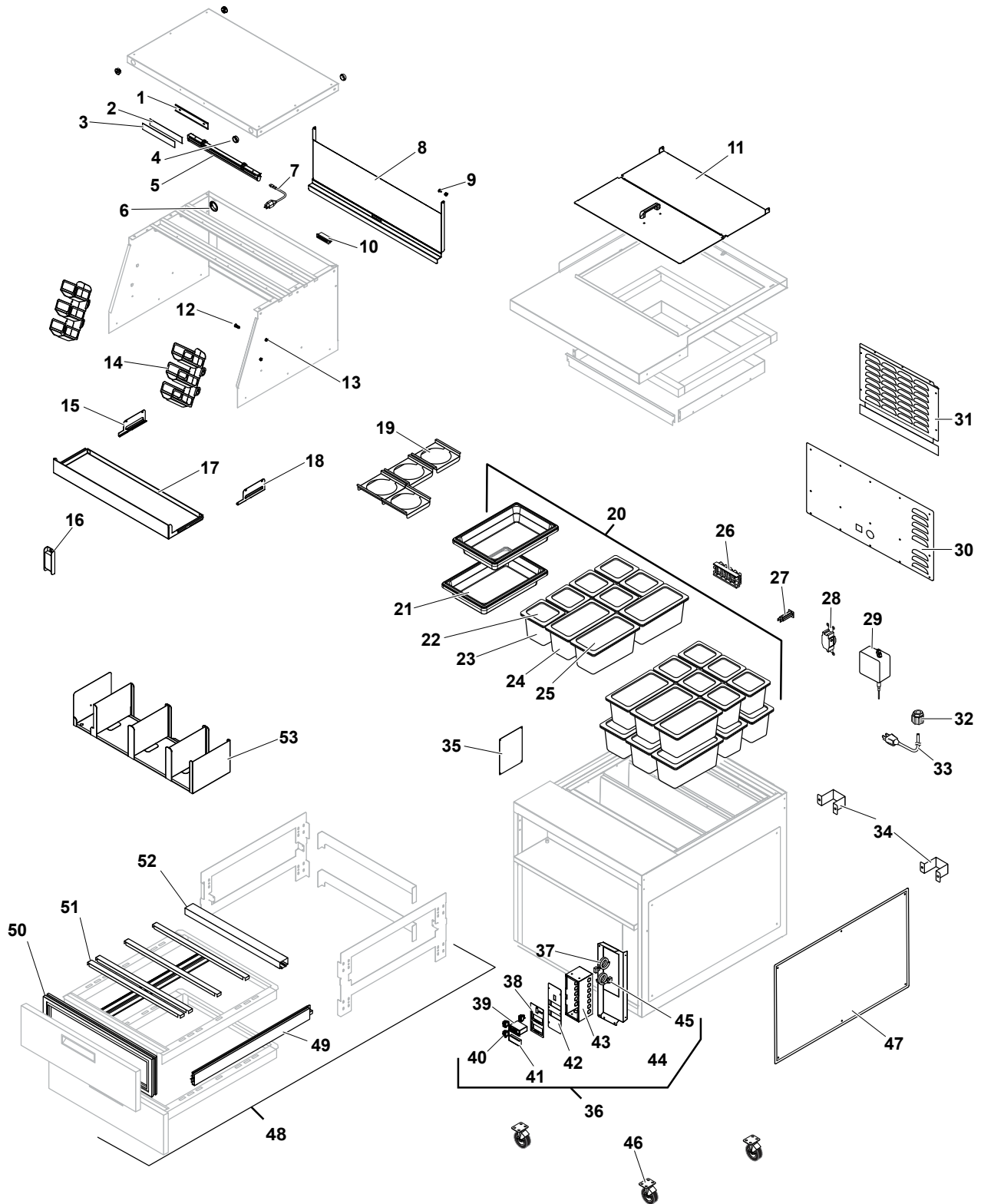

Figure: PL-9 32" Assembly Station

32" ASSEMBLY STATION

Item	Part No.	Description	Qty.
1	DD180098	COLD PAN LABEL HOLDER	1
2	224970	POLYCARBONATE, CP LABEL COVER WHITE- .015X8 x .1281	1
3	224969	POLYCARBONATE, CP LABEL COVER CL. .022X8 x .1281	1
4	214459	HEYCO BUSHING 1" HEY2140, BUSHING SNAP 1"	4
5	225890	LED, 17.375" LIGHT, W/ 2 MAGNETIC MOUNTING CLIPS & 1 SPEC TOOL	1
6	214236	GROMMET, ROUND 1.75" DIA BL #20609073-A030I	1
7	225891	CORD,LED 72" POWER, FOR 3L/LED 181CM AWG 18 SVT WHITE	1
8	DD060015	32" REAR WINDOW COVER	1
9	213028	SCREW, 10-24 x 3/8" PTHMS S/S	A/R
10	57100	CATCH, MAGNETIC 52-10-201-10	1
11	520265	32" NIGHT COVER ASSY	1
12	213390	BOLT, CARRIAGE, 10-24 x 1/2" SS MACHINE	4
13	213063	NUT, 10-24 NYLON INSERT Z	A/R
14	DD990097	SHORT BOTTLE HOLDER	2
15	E021053	BRACKET CRUMB TRAY LEFT	1
16	215318	MAGNET, W/STRIKE	1
17	E021055	CRUMB TRAY 32" REMOVABLE	1
18	E021054	BRACKET CRUMB TRAY RIGHT	1
19	DD990117	BUTTER HOLDER	4
20	DD-32-COOK-PAN-KIT	COOK STATION PAN KIT	1
21	227515	FOOD BOX, 18" x 12" x 3.5" #12183CW135	2
22	217506	LID, PAN 1/6 60CWCH135, CLEAR W/HANDLE	18
23	217505	PAN, 1/6 - 6" DEEP 66CW CLEAR	18
24	217503	PAN, 1/3 6" DEEP, 36CW, CLEAR	9
25	217504	LID, PAN 1/3 30CWCH135, CLEAR W/HANDLE	9
26	120001	BLOCK, TERMINAL 4 POLE	1
27	212309	CIRCUIT BREAKER COLD - 2 AMP	1
28	212177	RECPT, ELEC 5-15 SINGLE HBL5261	1
29	226044	SWITCH, PRESSURE	1
30	DD990196	32" UTILITY CHASE COVER	1
31	DD990171	32" PLATE COVER, REAR CHASE, LOUVERED	1
32	212117	STRAIN RELIEF, W/NUT	1
33	222100	CORD, W/PLUG NEMA 5-20	1
34	DD990068	REAR BUMPER BRACKET	2
35	DD990121	PLATE COVER FOR END PANEL W/ FAN ACCESS	1
36	520195	32" CONTROL ASSY	1
37	226051	HARNESS, WIRING FEMALE END	1
38	224971	LABEL, CP CONTROL 6.875X3.625 FOR 32" CP UNIT	1
39	520284	THERMOSTAT ELREHA DIGITAL DISPLAY KIT, SET UP FOR THE 32" CP UNIT	1
40	212288	SWITCH, LIGHTED	3
41	520285	DIGITAL THERM & CONTROL MODULE KIT, SET UP FOR THE 32" CP UNIT	1
42	DD990086	CONTROL PANEL PLATE	1
43	DD990087	CONTROL PANEL BOX	1
44	DD990085	CONTROL PANEL MOUNT	1
45	226050	HARNESS, MALE END WIRE	1
46	215002	CASTER, 3" DIA SWIVEL W/BRAKE 4" LOAD HEIGHT	4
47	DD990069	ACCESS PANEL	1
48	2500047	DRAWER SLIDE FRAME ASSY UTR	1
49	211602	SLIDE, DRAWER FR790CNS7926	2
50	211601	GASKET, MAGNETIC DOOR UTC	2
51	E021049	CHANNEL ADAPTER BAR UTR HORZ (<i>Units manufactured after 1/25/2017, Qty =8</i>)	6 or 8
52	2500048	MULLION ASSY HORZ UTR 1PC SLIDE FRAME	1
52	520267	32" STATION WRAPPER HOLDER ASSY	1

Table: PL-9 32" Assembly Station

32" ASSEMBLY STATION (CONT.)

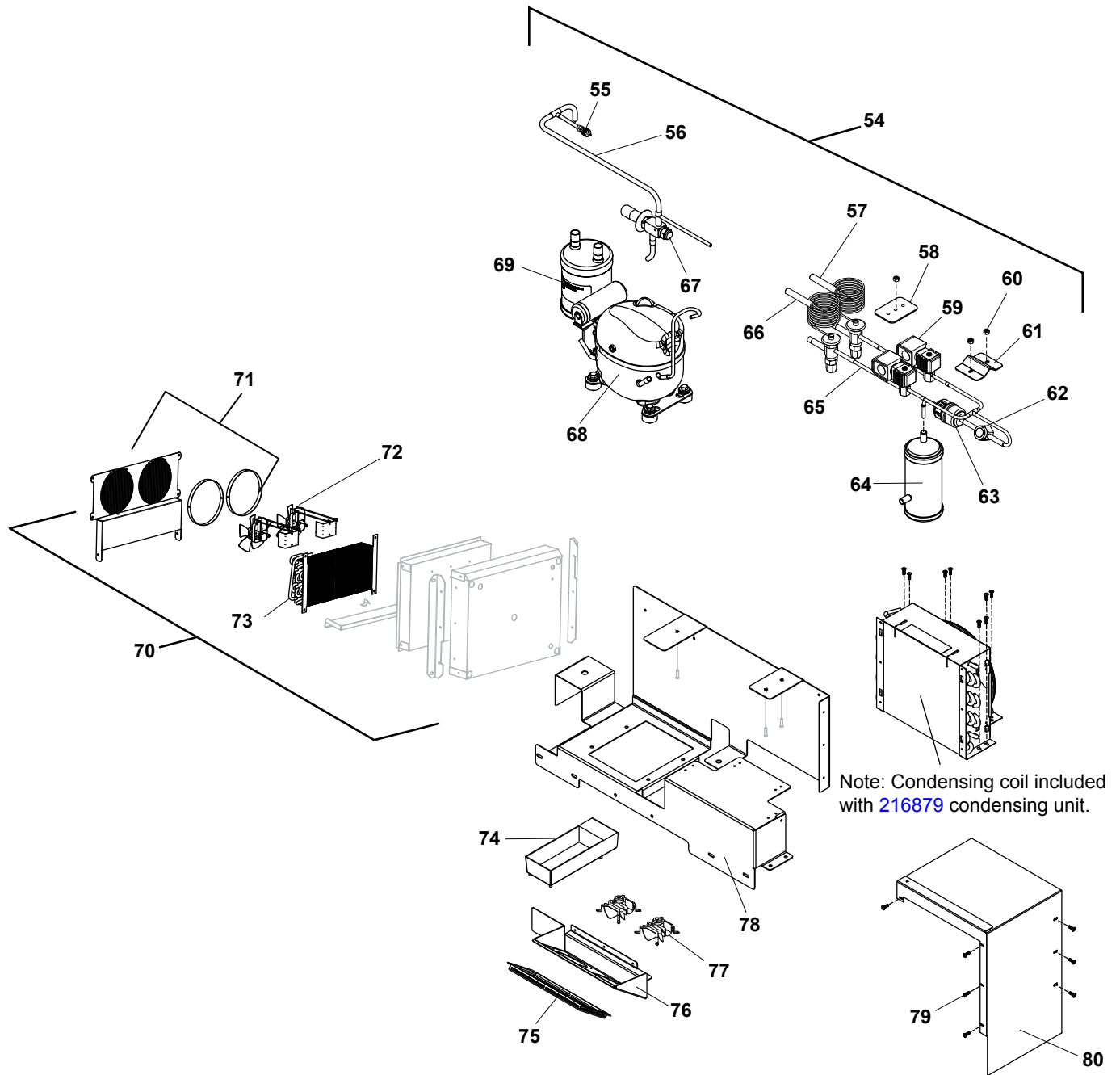

Figure: PL-10 32" Assembly Station (Cont.)

32" ASSEMBLY STATION (CONT.)

Item	Part No.	Description	Qty.
54	DD990158	32" COND UNIT ASSY	1
55	216547	VALVE 1/4 SCHRADER	3
56	226062	SUCTION LINE ASSEMBLY	1
57	520281	TXV VALVE KIT, SET FOR UTR SIDE OF 32" CONDENSING UNIT (Ref - 226061 Sporland #Y-1001-FBS-1/8-Z)	1
58	DD990147	PLATE COPPER TUBING SQUEEZE 32" DD	2
59	216553	SOLENOID, REFRIG W/COIL 120V (Ref - 226061, Sporland #E3S120)	2
60	213063	NUT, NYLON INSERT, 10-24	3
61	DD990210	SQUEEZE PLATE, LIQUID LINE	1
62	216415	GLASS, SIGHT STD#7 (Sporland #SA-12S)	1
63	226039	DRIER, FILTER (Sporland #C-033-S-T)	1
64	226052	RECEIVER Parker #RT306V-TS)	1
65	226061	TXV TUBE ASSEMBLY	1
66	520282	TXV VALVE KIT, SET FOR CP SIDE OF 32" CONDENSING UNIT (Ref - 226061, Sporland #Y-1001-FBS-1/8-Z)	1
67	520283	KIT, CPR VALVE (Ref - 226062, Sporland #CRO-4-0175)	1
68	527844	COMPRESSOR, 1/3 HP, 120V 60Hz (Ref-216879)	1
Not Shown	217808	FAN MOTOR (Ref - 216879, Emerson/Copeland #050-0298-01)	1
Not Shown	217809	FAN BLADE (Ref - 216879, Emerson/Copeland #083-0122-00)	1
Not Shown	217908	BRACKET, FAN MOTOR (Ref - 216879, Emerson/Copeland #074-7236-00)	1
Not Shown	217909	GUARD, FAN (Ref - 216879, Emerson/Copeland 024-0252-00)	1
Not Shown	217813	PROTECTOR (Ref - 16879, Emerson/Copeland #071-0561-16)	1
Not Shown	217843	START CAPACITOR (Ref - 216879, (Emerson/Copeland #014-0053-18)	1
Not Shown	217883	RELAY (Ref - 216879, Emerson/Copeland #040-0163-00)	1
Not Shown	217907	CONDENSOR (REF - 216879,Emerson/Copeland #066-0333-03)	1
69	520443	ACCUMULATOR, PARTS KIT	1
70	259895	ASSY, MECH UTR	1
71	520291	KIT, UTR FAN COVER (DD990170 & E021057)	1
72	71138	EVAPORATOR FAN MOTOR ASSY	2
73	216516	COIL, REFRIG EVAP	1
74	216608	EVAPORATOR, REFRIG 117V	1
75	DD180071	FAN COVER CHANNEL	1
76	DD180093	DUAL FAN CHANNEL 32	1
77	216772	FAN, 120V 50/60HZ, 115 CFM	2
78	DD990144	BRACKET CONDENSING UNIT 32" DD	1
79	213032	SCREW, 8 x 1/2 TEK PHIL	15
80	DD990157	AIR SHROUD 32" CP UNIT	1

Table: PL-10 32" Assembly Station (Cont.)

32" ASSEMBLY STATION SIDE SHELF KIT

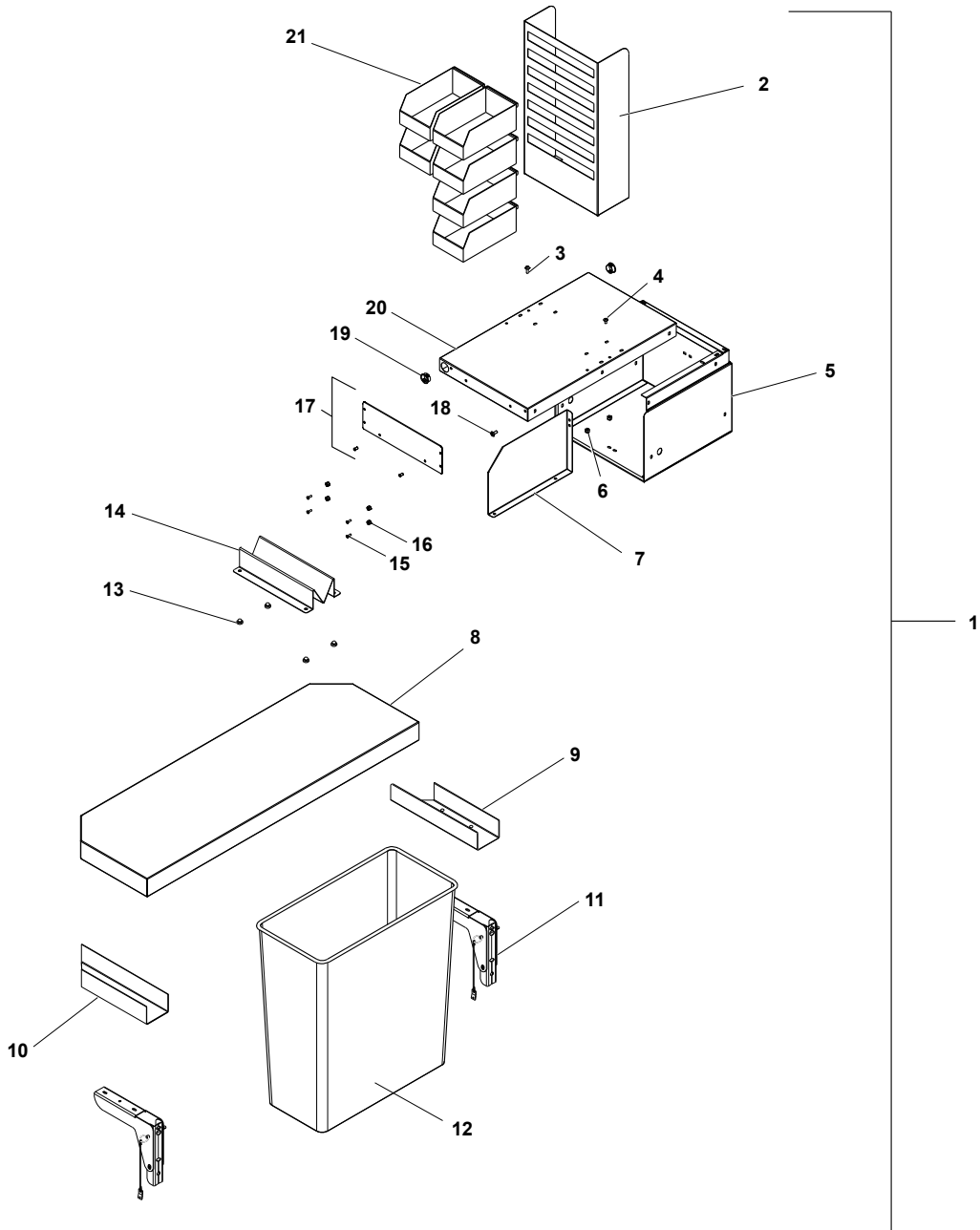

Figure: PL-11 32" Assembly Station Side Shelf Kit

32" ASSEMBLY STATION SIDE SHELF KIT

Item	Part No.	Description	Qty.
1	520240-2	KIT, SIDE SHELF ASSEMBLY, 32" ASSEMBLY STATION	1
2	DD990077	UPRIGHT BIN SUPPORT	1
3	213141	SCREW, 1/4-20 x 5/8 SS MS, RD HEAD SLOTTED	4
4	213360	SCREW, 10-24 x 3/8 PTMS SS W/NYLOK PATCH	4
5	DD990214	SHORT SIDE PRINTER SHELF SUPPORT	1
6	213063	NUT, 10-24 NYLON INSERT Z	17
7	DD990213	BAG DIVIDER	1
8	DD140047	SIDE SHELF W/ CHAMFER	1
9	DD180099-LT	SIDE SHELF CHANNEL W/ CHAMFER	1
10	DD180099-RT	SIDE SHELF CHANNEL W/ CHAMFER	1
11	DD990179	DROP BRACKET ASSEMBLY	2
12	214946	CAN, TRASH 19" x 9.5" x 21"t TALL, BLCK ABS PLASTIC	1
13	71181	BUMPER, BUTTON	4
14	DD990216	SMALL HASH BROWN HOLDER	1
15	213353	SCREW,6-32 x 7/16" PHFHMS S PHILIPS FLAT HEAD	4
16	213406	NUT, KEPS 6-32 HEX SS	4
17	520268	KIT, BUMP BAR PLATE (DD990039 & 213178)	1
18	213027	SCREW, 10-24 x 1/2" PTHMS S/S	11
19	214459	HEYCO BUSHING 1" HEY2140, BUSHING SNAP 1"	2
20	DD140062	OVER SHELF TOP PANEL	1
21	228300	BIN, PLASTIC CLEAR 4.125" x 7.375" x 3"	6

Table: PL-11 32" Assembly Station Side Shelf Kit

32" ASSEMBLY STATION WITH "KOOL" SYSTEM

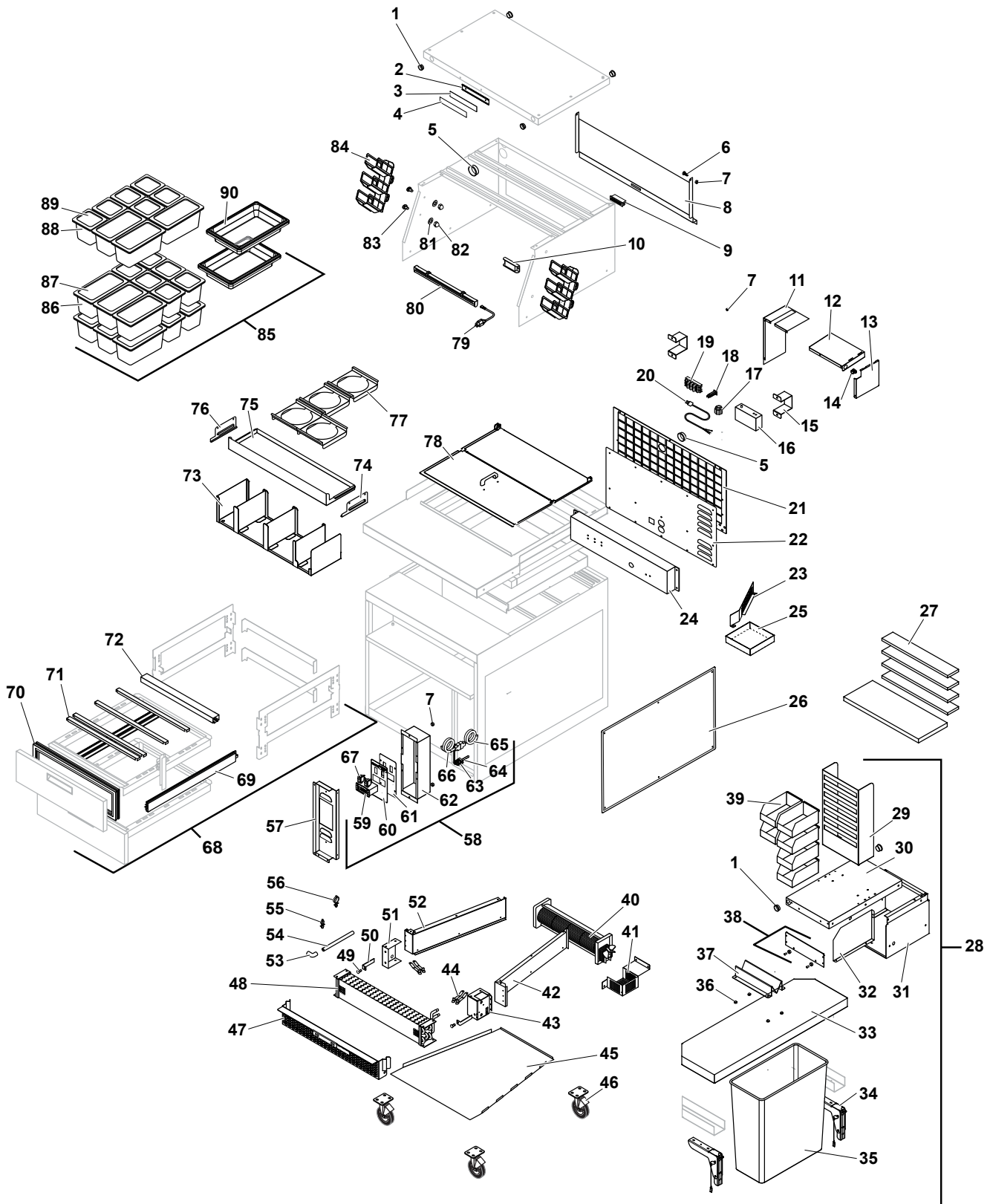

Figure: PL-12 32" Assembly Station with "Kool" System

32" ASSEMBLY STATION WITH "KOOL" SYSTEM

Item	Part No.	Description	Qty.
1	214459	HEYCO BUSHING 1" HEY2140, BUSHING SNAP 1"	4
2	DD180098	COLD PAN LABEL HOLDER	1
3	224970	POLYCARBONATE, CP LABEL COVER WHITE- .015X8X.1281	1
4	224969	"POLYCARBONATE, CP LABEL COVER CL.	1
5	214236	GROMMET,ROUND 1.75"DIA BL #20609073-A030I	2
6	213028	SCREW,10-24x3/8" PTHMS S/S	2
7	213063	NUT,10-24 NYLON INSERT Z	19
8	DD060015	32" REAR WINDOW COVER-NO AUDIT REQUIRED	1
9	57100	CATCH,MAGNETIC	1
10	215318	MAGNET,#M35-1000 W/STRIKE SUBWAY DOORS MAGNET	1
11	DD990312	LEFT AIR DEFLECTOR	1
12	DD990333	DEFLECTOR, AIR TOP 32 "KOOL"	1
13	DD990334	DEFLECTOR, AIR SIDE 32 "KOOL"	1
14	212023	BUSHING,HEYCO SB-875-11	2
15	DD990068	REAR BUMPER BRACKET	2
16	216891	SWITCH, PRESSURE CONTROL ICE CREAM UNIT	1
17	212117	STRAIN RELIEF,W/ 1/2" LOCK NUT SHC1022CR	1
18	212309	CIRCUIT BREAKER COLD - 2 AMP #TYCO #3-1393250-2	1
19	120001	BLOCK,TERMINAL 4 POLE	1
20	212170	CORD,W/PLUG 5-15 14/3 6 FT 15A 1Ph	1
Not Shown	212022	RECPT,ELEC 5-15 DUPLEX	1
21	DD990287	32 REAR PERF PANEL	1
22	RT990020	32" UTILITY CHASE COVER W/DUPLEX OUTLET	1
23	DD990294	COND. PAN SUPPORT	1
24	DD990289	32 REAR CHASE	1
25	254547	PAN CONDENSATE COLLECTION SW UTR	1
26	DD990293	ACCESS PANEL 32	1
27	520305	KIT, FILTER REPLACEMENT (4-224940 Filters)	
28	520240-2	32" ASY STATION SIDE SHELF ASM PHASE2	1
29	DD990077	UPRIGHT BIN SUPPORT	1
30	DD140062	OVER SHELF TOP PANEL	1
31	DD990214	SHORT SIDE PRINTER SHELF SUPPORT	1
32	DD990213	BAG DIVIDER	1
33	DD140047	SIDE SHELF W/ CHAMFER	1
34	DD990179	DROP BRACKET ASSEMBLY	2
35	214946	CAN, TRASH 19x9.5x21t TALL, BLCK ABS PLASTIC	1
36	71181	BUMPER, BUTTON 7-ELEVEN Q99-26012	4
37	DD990216	SMALL HASH BROWN HOLDER	1
38	520268	BUMP BAR PLATE KIT (DD990039 & 213178)	1
39	228300	BIN,PLASTIC CLEAR 4.125X7.375X3	6
Not Shown	213027	SCREW,10-24x1/2" PTHMS S/S	4
Not Shown	213360	SCREW,10-24x3/8 PTMS SS W/NYLOK PATCH	4
Not Shown	213353	SCREW,6-32X7/16" PHFHMS S PHILIPS FLAT HEAD	4
40	600540	KIT, TANGENTIAL MOTOR REPLACEMENT (Ref-226960)	1
41	DD990285	32 MOTOR GUARD	1
42	DD990282	32 LEFT DUCT END	1
43	DD990264	COIL END BRACKET LONG (514788 Nutsert must be Factory Installed)	1

Table: PL-12 32" Assembly Station with "Kool" System

32" ASSEMBLY STATION WITH "KOOL" SYSTEM (CONT.)

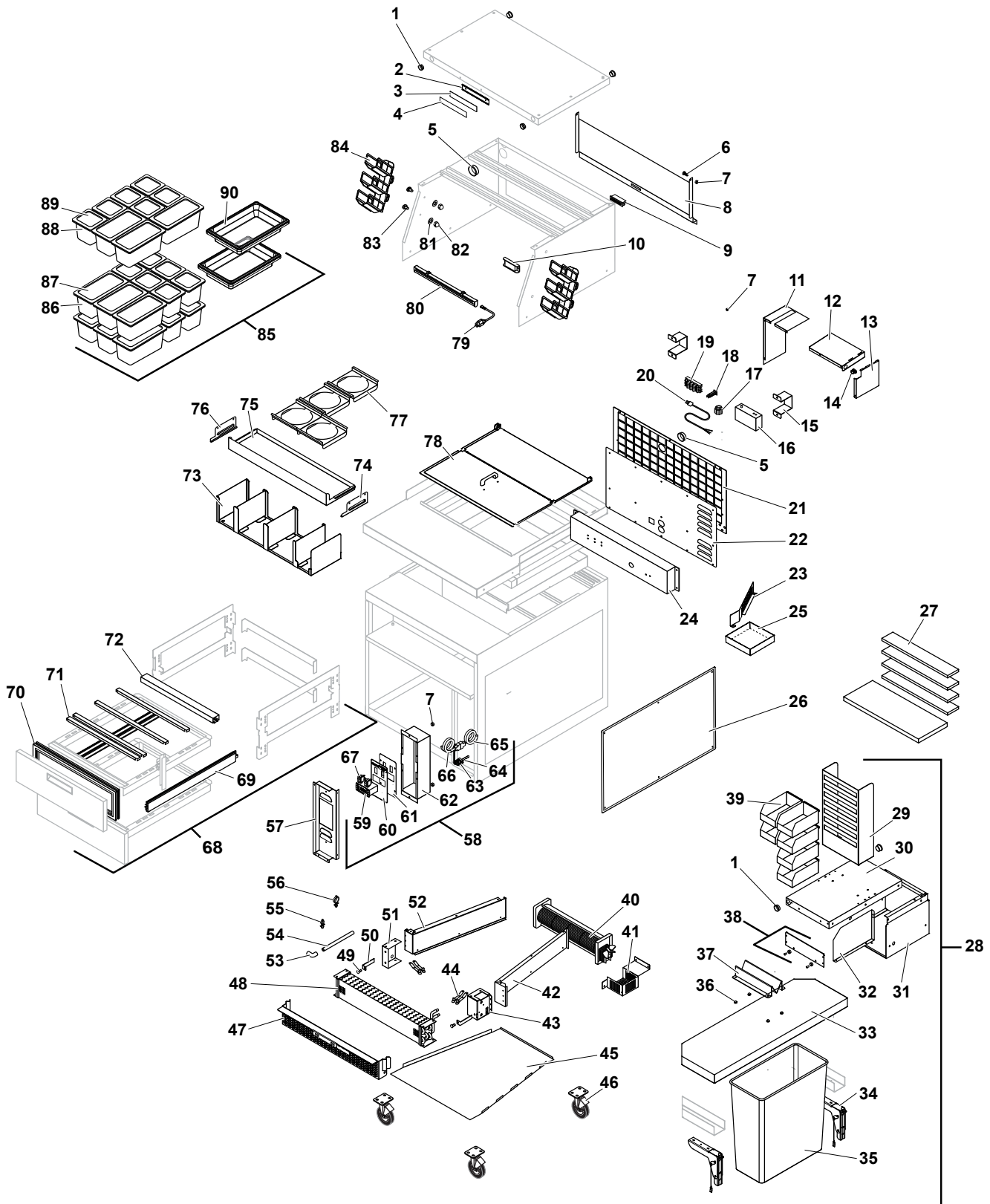

Figure: PL-12 32" Assembly Station with "KOOL" System (cont.)

32" ASSEMBLY STATION WITH "KOOL" SYSTEM (CONT.)

Item	Part No.	Description	Qty.
44	225400	CLIP, SPRING VALCO #F-162	4
45	DD990284	32 BOTTOM DUCT PLATE	1
46	215002	CASTER,3"DIA SWIVEL W/BRAKE 4" LOAD HEIGHT	4
47	DD990329	COIL COVER GRILLE	1
48	226790	COIL, CONDENSER 20x4 .375 TUBE	1
49	213360	SCREW,10-24x3/8 PTMS SS W/NYLOK PATCH	2
50	DD990330	RETAINER CLIP	2
51	DD990265	COIL END BRACKET SHORT (514788 Nutsert must be Factory Installed)	1
52	DD990283	32 RIGHT DUCT END	1
53	224408	ELBOW, 3/8" PLASTIC PUSH FIT	1
54	DD990318	UTR DRAIN TUBE	1
55	222232	STAND OFF, WIRE PANDUIT WS35-25-C	1
56	222233	STAND OFF, WIRE PANDUIT WS75-25-C	1
57	DD990327	32" CONTROL MOUNT	1
58	520303	DUNKIN CONTROL ASM	1
59	224409-KK	CUSTOM PROGRAMMED THERMOSTAT	1
60	224973	LABEL, CP CONTROL 3.75X7 FOR FRONT BREATHING CP UNIT	1
61	DD990292	32 CONTROL COVER PLATE	1
62	DD990326	CONTROL BOX	1
63	222101	BUSHING,HEYCO 1280 STRAIN RELIEF	2
64	216812	PROBE, 1.8" NTC 1.5 METER WIRE	3
65	226059	HARNESS, WIRING FEMALE END 2nd GEN	1
66	226058	HARNESS, MALE END WIRE 2nd GEN	1
67	212288	SWITCH,LIGHTED SUBWAY 120	2
68	2500047	DRAWER SLIDE FRAME ASSY UTR	1
69	211602	SLIDE, DRAWER FR790CNS7926	2
70	211601	GASKET, MAGNETIC DOOR UTC	2
71	E021049	CHANNEL ADAPTER BAR UTR HORZ (<i>Units manufactured after 1/25/2017, Qty =8</i>)	6 or 8
72	2500048	MULLION ASSY HORZ UTR 1PC SLIDE FRAME	1
73	520267	32" ASY STATION WRAPPER HOLDER ASM	1
74	E021054	BRACKET CRUMB TRAY RIGHT	1
75	E021055	CRUMB TRAY 32" REMOVABLE	1
76	E021053	BRACKET CRUMB TRAY LEFT	1
77	DD990117	BUTTER HOLDER	4
78	520265	32" NIGHT COVER ASM	1
79	225891	CORD,LED 72" POWER, FOR 3L/LED 181CM AWG 18 SVT WHITE	1
80	225890	LED, 17.375" LIGHT, W/2 MAG MOUNTING CLIPS & 1 SPEC TOOL	1
81	213040	NUT,10-24 HEX CAP NICKEL PLATED MILD STEEL	4
82	213055	WASHER,AN960-C10L,18-8 SS	4
83	213390	BOLT,CARRIAGE 10-24X1/2SS MACHINE	4
84	DD990097	SHORT BOTTLE HOLDER	2
85	DD-32-COOK-PAN-KIT	Pan Kit for 38" Assembly Station (217503-217504-217505-217506-227515)	1
86	217503	Pan,1/3 6" Deep, Clear (Component of DD-32-COOK-PAN-KIT)	1
87	217504	Lid, Pan 1/3, Clear W/Handle (Component of DD-32-COOK-PAN-KIT)	1
88	217505	Pan,1/6 6" Deep, Clear (Component of DD-32-COOK-PAN-KIT)	1
89	217506	Lid, Pan 1/6, (Component of DD-32-COOK-PAN-KIT)	1
90	227515	Pan, 18" x 12" x 3.5" (Component of DD-32-COOK-PAN-KIT)	1
Not Shown	213406	NUT,KEPS 6-32 HEX SS	4
Not Shown	213141	SCREW,1/4-20 X 5/8 SS MS, RD HEAD SLOTTED	4

Table: PL-12 32" Assembly Station with "Kool" System (cont.)

32" ASSEMBLY STATION WITH "KOOL" SYSTEM (CONT.)

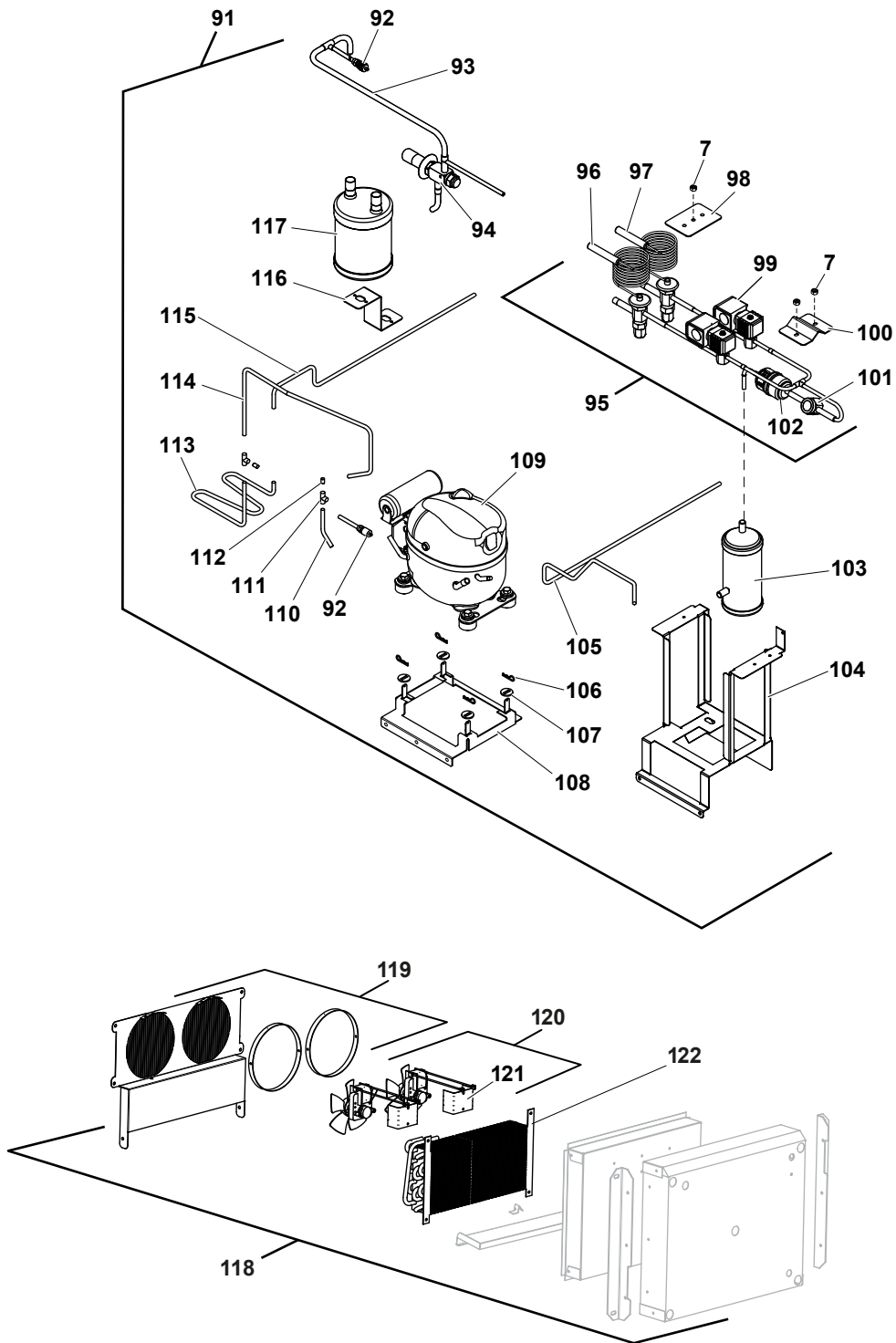

Figure: PL-13 32" Assembly Station with "KOOL" System (cont.)

32" ASSEMBLY STATION WITH "KOOL" SYSTEM (CONT.)

Item	Part No.	Description	Qty.
91	520304	32" COND UNIT ASM	1
92	216547	VALVE 1/4 SCHRADER #vax-4	2
93	226062	MANIFOLD, SUCTION LINE ASSB. #071795-02	1
94	520283	CPR VALVE KIT, SET UP FOR 32" CONDENSING UNIT (Ref-226062)	1
95	226061	MANIFOLD, LIQUID LINE ASSB. #071795-01	1
96	520282	"TXV VALVE KIT, SET FOR CP SIDE OF 32"" CONDENSING UNIT (Ref - 226061 , Sporland #Y-1001-FBS-1/8-Z)"	1
97	520281	"TXV VALVE KIT, SET FOR UTR SIDE OF 32"" CONDENSING UNIT (Ref - 226061 , Sporland #Y-1001-FBS-1/8-Z)"	1
98	DD990147	PLATE COPPER TUBING SQUEEZE 32" DD	1
99	216553	SOLENOID, REFR IG. W/COIL 120V (Ref - 226061 , Sporland #E3S120)	2
100	DD990210	SQUEEZE PLATE, LIQUID LINE	1
101	216415	Sight Glass , STD, #7 (Ref- 226061 , Sporland #SA-12S)	1
102	226039	Drier, Filter (Ref- 226061 , Sporland #C-033-S-T)	1
103	226052	RECEIVER, Parker P# RT306V-TS	1
104	DD990280	Suction Line Support-32 (3-115174 Pem Studs, Must Be Installed. Ref-520304)	1
105	DD990317K	HOT GAS CONDENSER TUBE	1
106	213217	CLIP, HAIRPIN # 213	4
107	290047	WASHER COMPRESSOR FROST TOP	4
108	DD990281	32 COMPRESSOR SUPPORT	1
109	527844	Replacement Compressor, 1/3HP 120V 60HZ (Ref-226841 & 216879)	1
110	DD100017K	PRESSURE REGULATOR TUBE	1
111	216512	TEE, 1/4x1/4x1/4 COPPER SWEAT	2
112	223587	BUSHING, BRAZED .094ID X 0.25 OD X .375 LONG, 110 COPPER	2
113	DD990299K	EVAP TUBE	1
114	DD990315K	CONDENSATE EVAP TUBE	1
115	DD990316K	HOT GAS CONDENSER TUBE	1
116	DD990325	ACCUMULATOR MOUNT	1
117	520443	ACCUMULATOR, PARTS KIT	1
118	259895	ASY, MECH UTR	1
Not Shown	212023	BUSHING,HEYCO SB-875-11	2
119	520291	UTR FAN COVER KIT (DD990170 & E01057)	1
120	71138	EVAPORATOR FAN MOTOR ASSY 5A145-175P	2
121	E990074	MOTOR MOUNT UTR	2
122	216516	COIL, REFRIG EVAP R-134A	1

Table: PL-13 32" Assembly Station with "Kool" System (cont.)

40" TOAST STATION

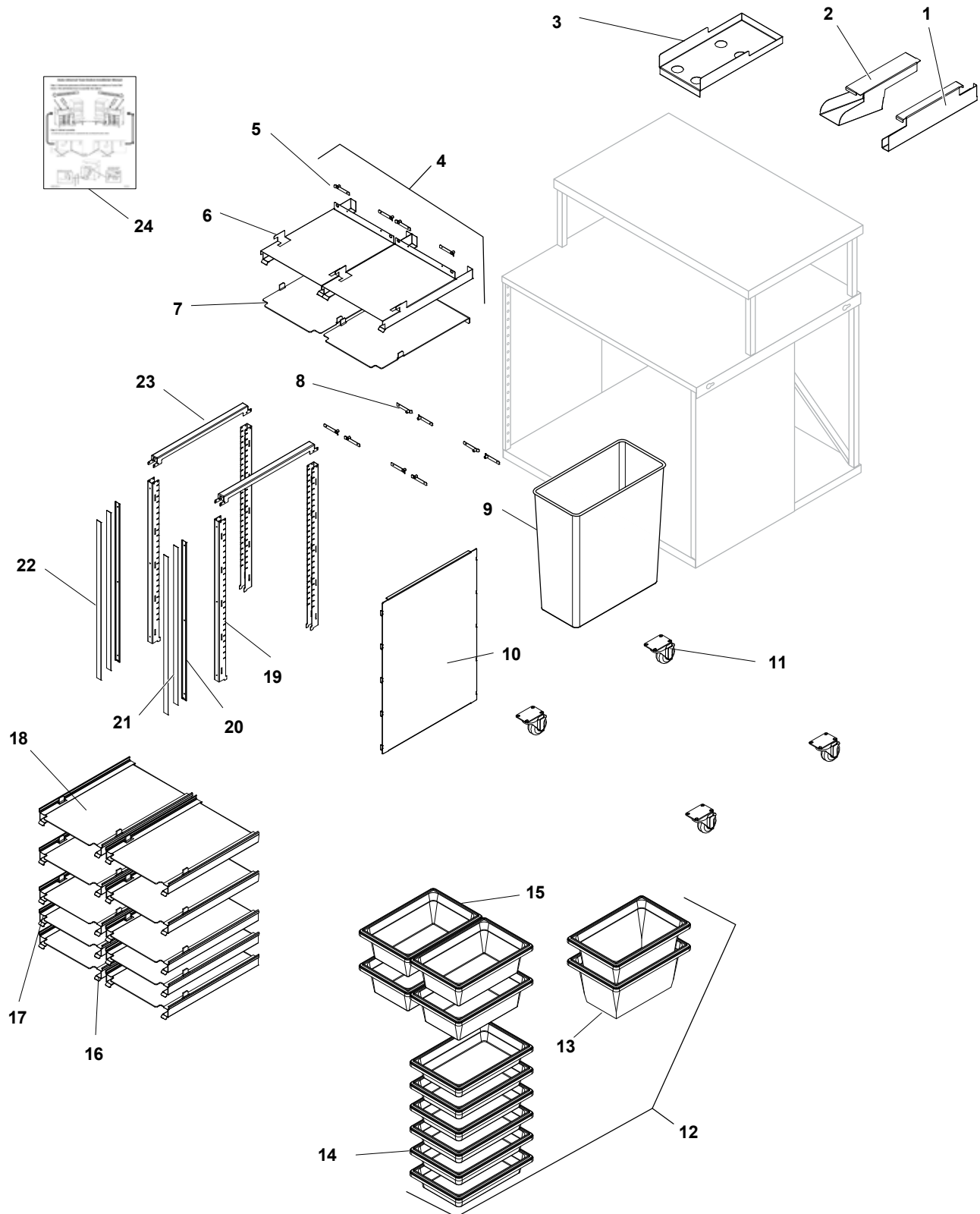

Figure: PL-14 40" Toast Station

40" TOAST STATION

Item	Part No.	Description	Qty.
1	DD990044	KNIFE HOLDER	1
2	DD990209	TONG HOLDER ANGLED	1
3	DD990207	BAGEL TRAY	1
4	DD990211	UNDERSHELF PAN SUPPORT ASSY	2
5	225400	CLIP, SPRING VALCO #F-162	4
6	DD180108	UNDER SHELF PAN SUPPORT	2
7	DD990090	PAN COVER ACRYLIC W/ STOPS	2
8	225400	CLIP, SPRING VALCO #F-162	8
9	214946	CAN, TRASH 19 x 9.5 x 21t TALL, BLCK ABS PLASTIC	1
10	DD990208	TOAST CART WASTE PARTITION	1
11	215002	CASTER, 3" DIA SWIVEL W/BRAKE 4" LOAD HEIGHT	4
12	DD-40TOAST-PAN-KIT	PAN KIT ASSY FOR TOAST STATION	1
13	227517	12 x 18 x 9" CLEAR ACRYLIC	2
14	227515	12 x 18 x 3.5" CLEAR ACRYLIC	6
15	227516	12 x 18 6" CLEAR ACRYLIC	4
16	520277	RIGHT ADJUSTABLE HANGING PAN SUPPORT KIT	6
17	520276	LEFT ADJUSTABLE HANGING PAN SUPPORT KIT	6
18	DD990090	PAN COVER ACRYLIC W/ STOPS	6
19	DD180105	SUPPORT CHANNEL TOAST CART	4
20	DD180097	TOAST CART LABEL HOLDER	2
21	224968	TOAST CART LABEL BACKER- .015 STYRENE WHITE .015 x 28.188 x .0906	2
22	224967	TOAST CART LABEL, COVER-.020 PETG CLEAR .020 x 28.188 x .0906	2
23	DD180106	TOAST CART CROSS MEMBER	2
24	229053	MANUAL, 40" TOAST CART	1

Table: PL-14 40" Toast Station

27" TOAST STATION WITH RIGHT TO LEFT PRODUCT FLOW

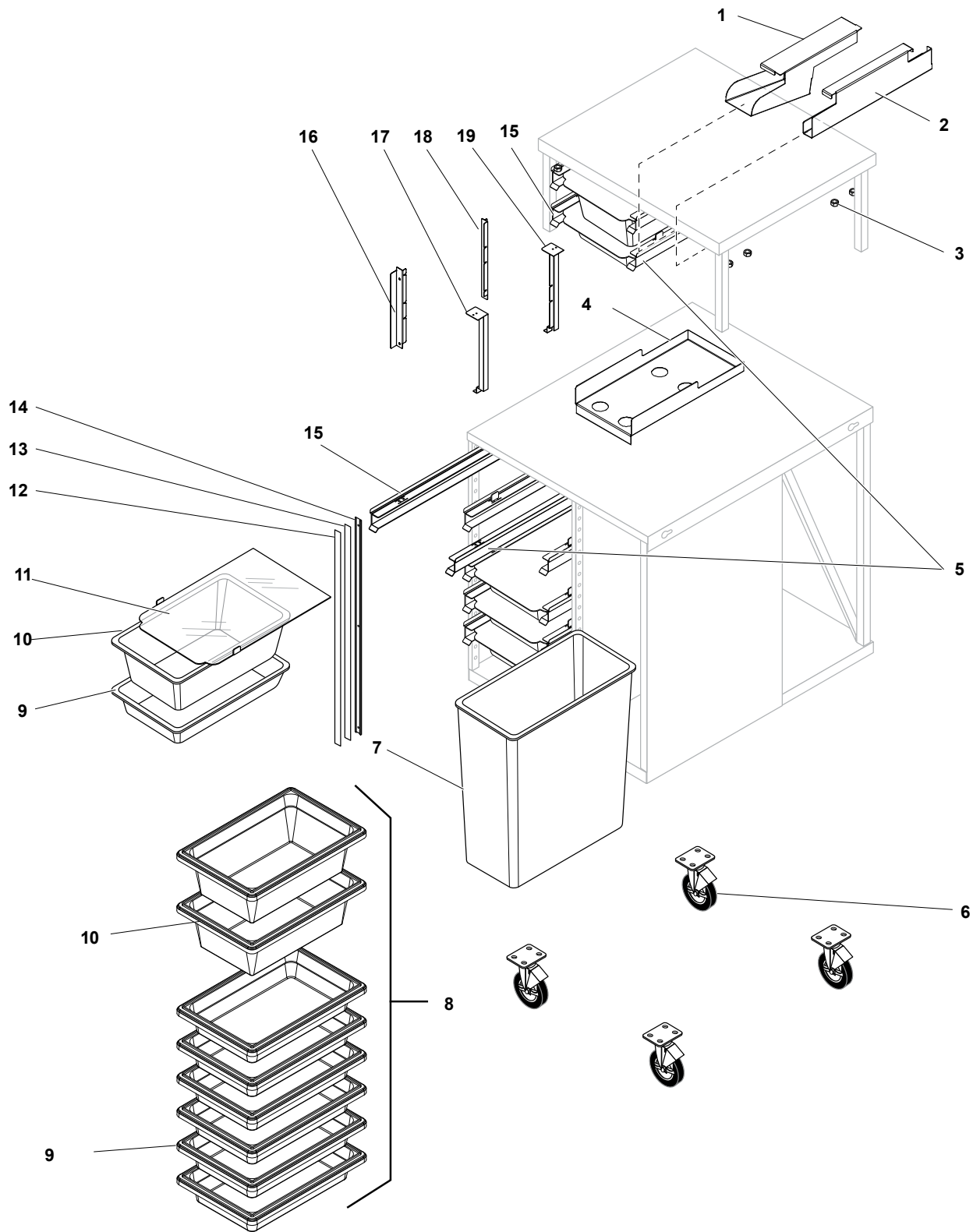

Figure: PL-15 27" Toast Station with Right to Left Product Flow

27" TOAST STATION WITH RIGHT TO LEFT PRODUCT FLOW

Item	Part No.	Description	Qty
1	DD990209	TONG HOLDER ANGLED	1
2	DD990044	KNIFE HOLDER	1
3	213063	NUT,10-24 NYLON INSERT Z	A/R
4	DD990207	BAGEL TRAY	1
5	520277	KIT, RIGHT ADJUSTABLE HANGING PAN SUPPORT	6
6	215002	CASTER, 3" DIA SWIVEL W/BRAKE 4" LOAD HEIGHT	4
7	214946	CAN, TRASH 19 x 9.5 x 21t TALL, BLCK ABS PLASTIC	1
8	DD-27-TOAST-PAN-KIT	PAN KIT ASSY FOR TOAST STATION	1
9	227515	12 x 18 x 3.5" CLEAR ACRYLIC	6
10	227516	12 x 18 6" CLEAR ACRYLIC	2
11	DD990090	PAN COVER ACRYLIC W/ STOPS	8
12	224967	TOAST CART LABEL, COVER-.020 PETG CLEAR .020 x 28.188 x .0906	1
13	224968	TOAST CART LABEL BACKER- .015 STYRENE WHITE .015 x 28.188 x .0906	1
14	DD180097	TOAST CART LABEL HOLDER	1
15	520276	KIT, LEFT ADJUSTABLE HANGING PAN SUPPORT	6
16	DD050038	RT UPPER TOAST CART END ANGLED	1
17	DD050039	UPPER TOAST CART SLIDE CHAN FRNT CNT	1
18	DD050037	LT UPPER TOAST CART END ANGLED	1
19	DD050040	UPPER TOAST CART SLIDE CHAN REAR CNT	1

Table: PL-15 27" Toast Station with Right to Left Product Flow

18" EXPEDITE TABLE

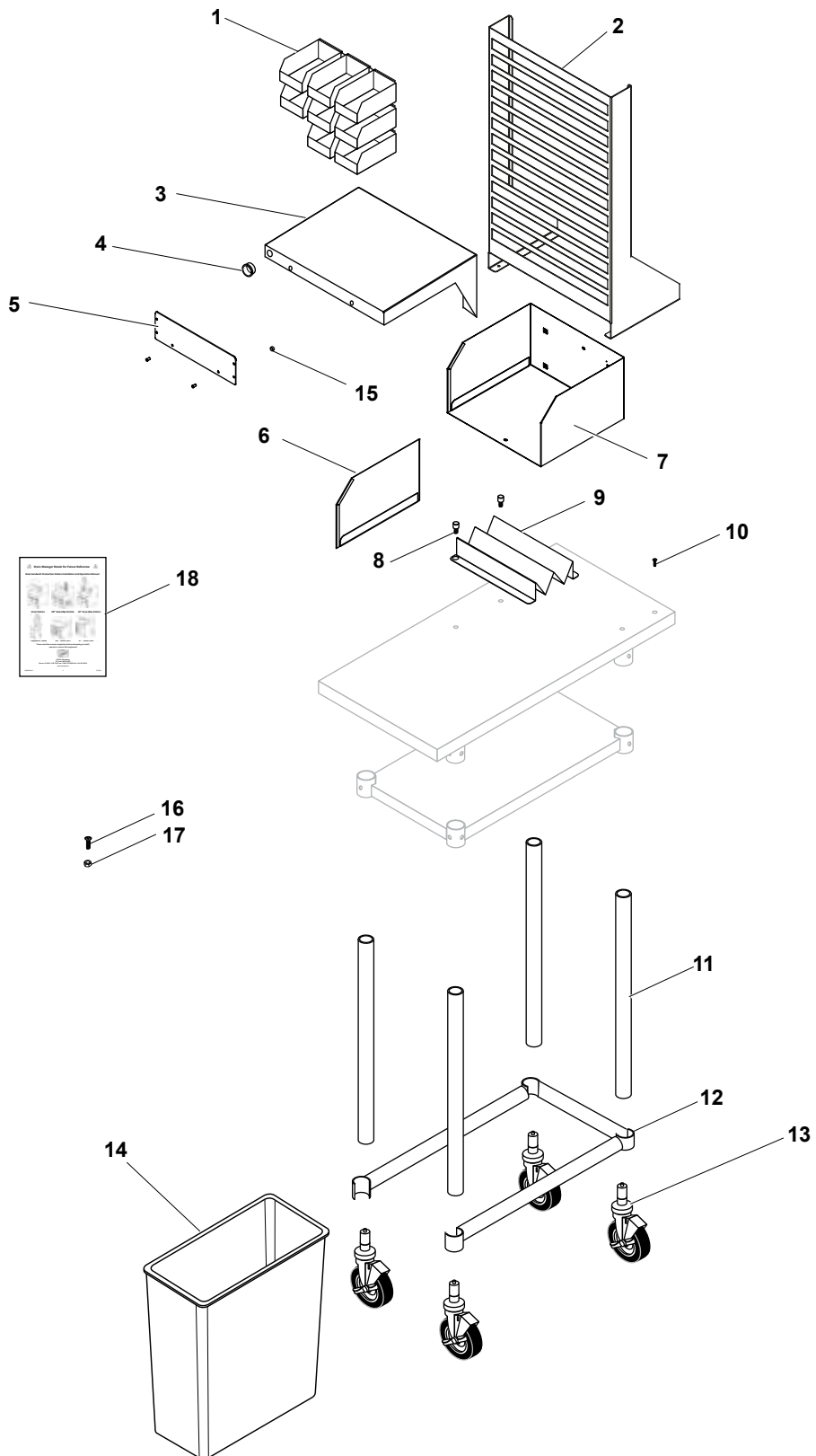

Figure: PL-16 18" Expedite Table

18" EXPEDITE TABLE

Item	Part No.	Description	Qty
1	228300	BIN, PLASTIC CLEAR 4.125 x 7.375 x 3	8
2	DD990156	UPRIGHT BIN SUPPORT	1
3	DD140054	EXPEDITE PRINTER SHELF	1
4	214459	HEYCO BUSHING 1" HEY2140, BUSHING SNAP 1"	1
5	520268	KIT, BUMP BAR PLATE	1
6	DD990213	BAG DIVIDER	1
7	DD990212	BAG HOLDER	1
8	214728	STUD, POSITION SS CARV BRD SET SCREW LENGTH- 5/8"	2
9	DD990059	HASH BROWN HOLDER	1
10	213360	SCREW, 10-24 x 3/8 PTMS SS W/NYLOK PATCH	7
11	DD190006	S.S. TABLE LEG - 27.375" FOR 34.75" OAH W/ CASTER	4
12	DD190005	TUBE BASE SS-16.125 x 28	1
13	214517	CASTER, 5"SWIVEL W/B 1-5/8	4
14	214946	CAN, TRASH 19x9.5x21t TALL, BLCK ABS PLASTIC	1
15	213063	NUT,10-24 NYLON INSERT Z	9
16	213353	SCREW,6-32X7/16" PHFHMS S PHILIPS FLAT HEAD	4
17	213406	NUT,KEPS 6-32 HEX SS	4
18	229051	INSTRUCTIONS	1

Table: PL-16 18" Expedite Table

SANDWICH PRODUCTION STATION FLOW CHART AND SPECS

SANDWICH PRODUCTION STATION REFRIGERANT FLOW & SPECS (32" and 38" Models)

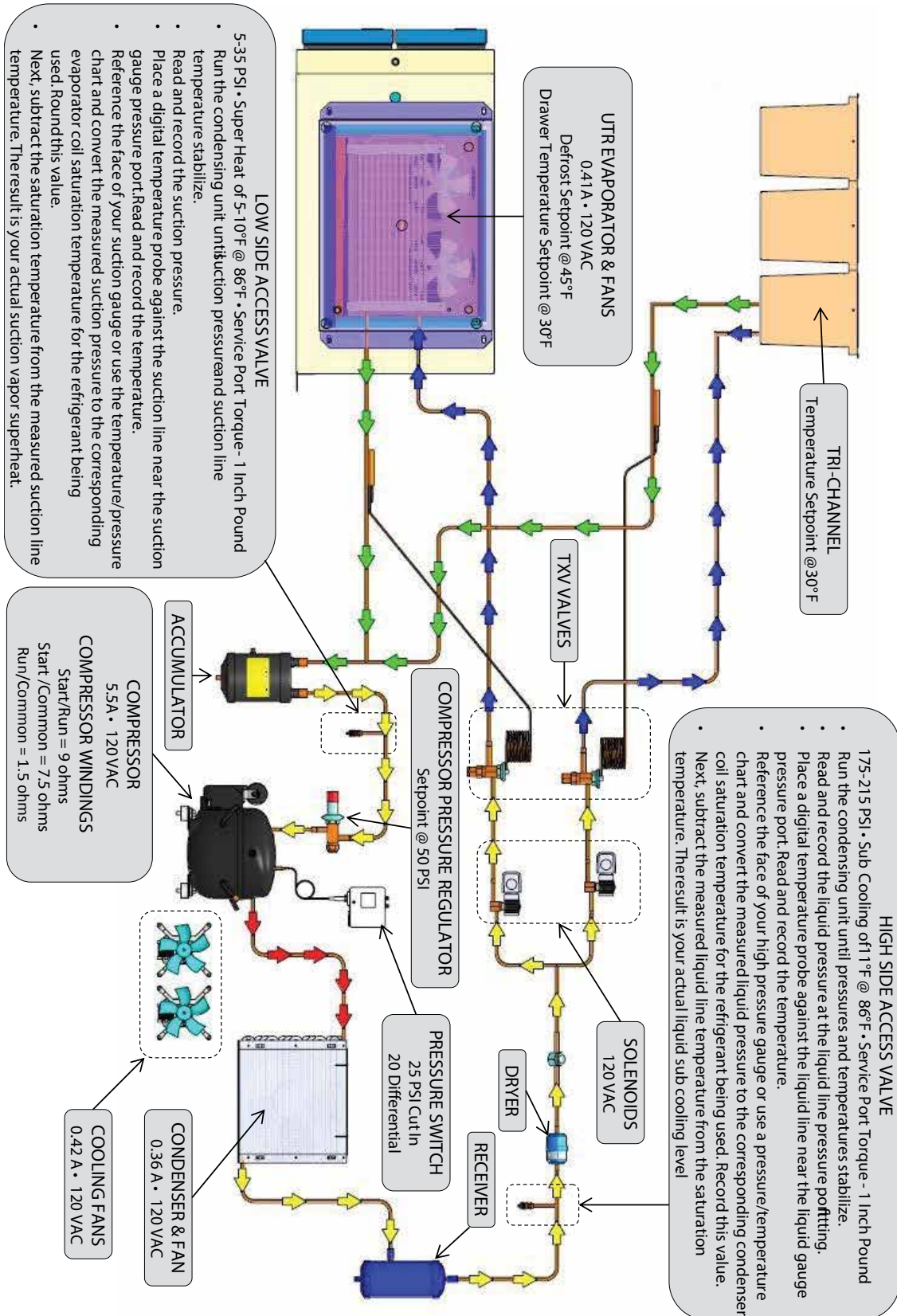

SANDWICH PRODUCTION STATION - "KOOL" SYSTEM - FLOW CHART AND SPECS

SANDWICH PRODUCTION STATION KOOL SYSTEM REFRIGERANT FLOW & SPECS (32" and 38" Models)

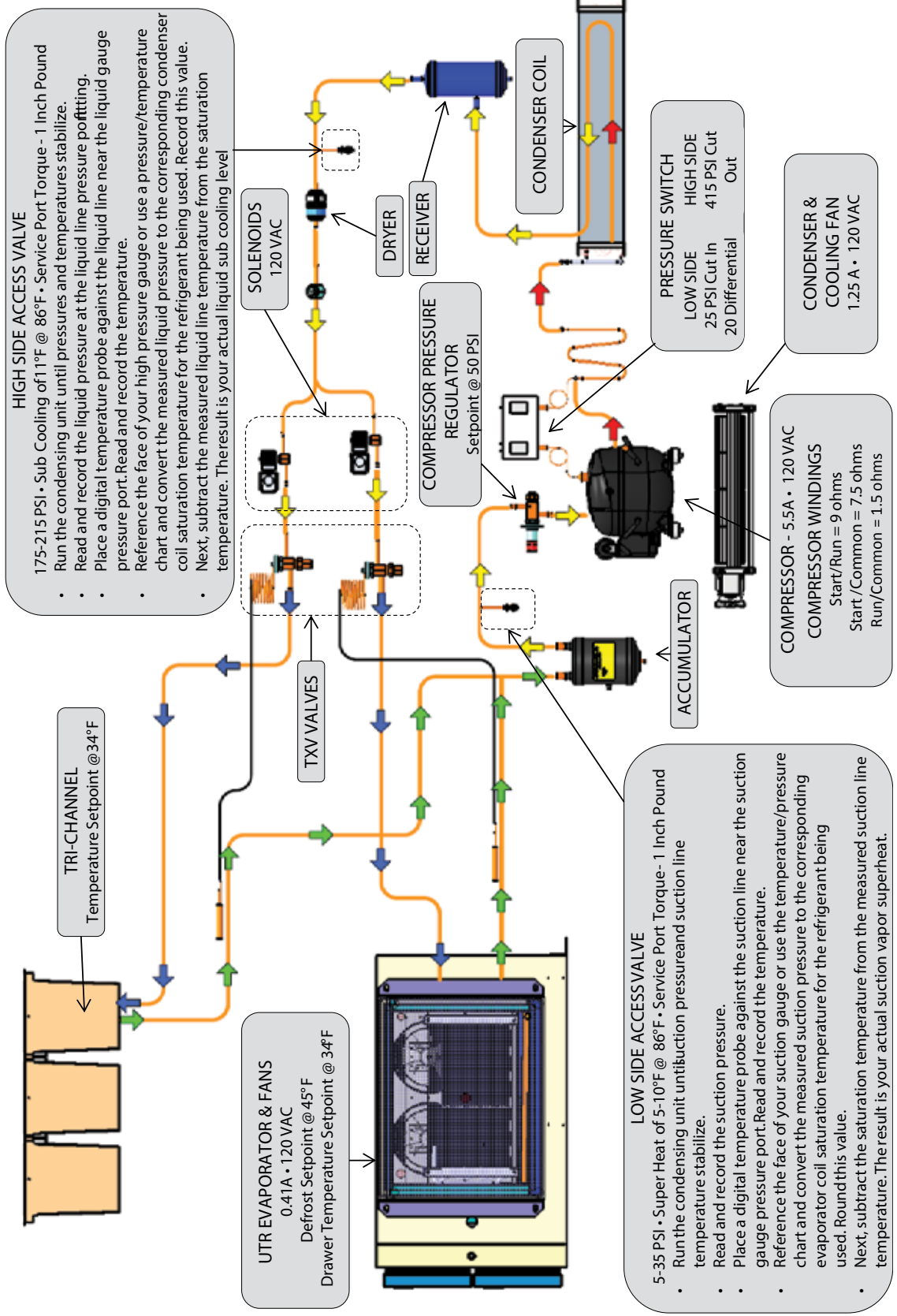

WIRING DIAGRAM – SANDWICH PRODUCTION STATION

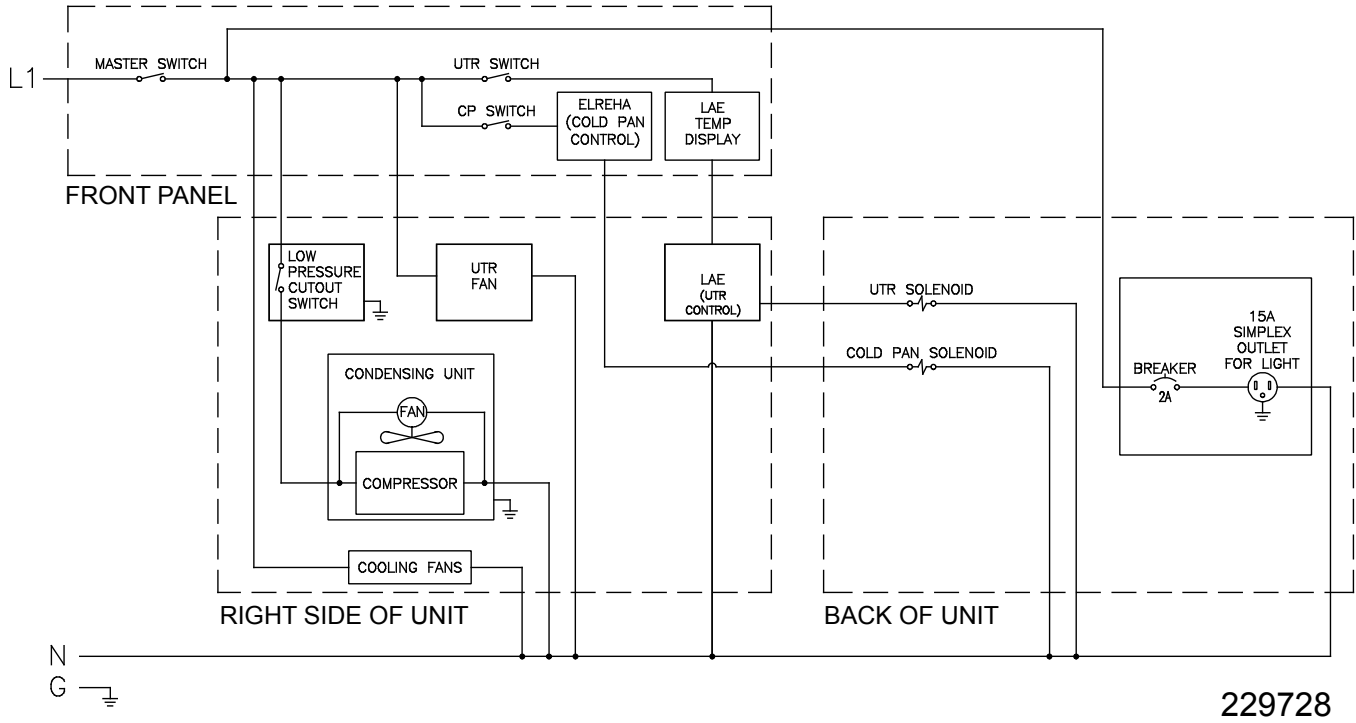

WIRING DIAGRAM – SANDWICH PRODUCTION STATION WITH “KOOL” SYSTEM

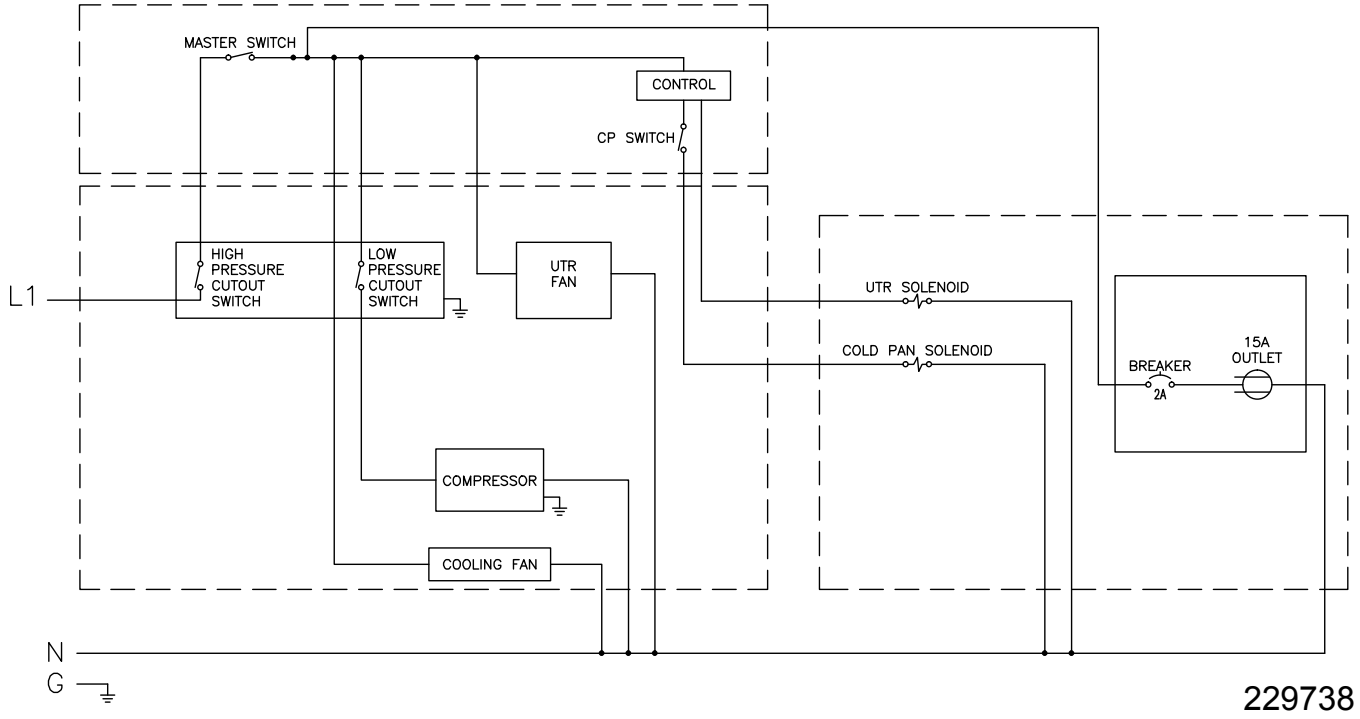



NOTES

NOTES



Your Solutions Partner

Duke Manufacturing Company

2305 N. Broadway
St. Louis, MO 63102
Phone: 314-231-1130
Toll Free: 1-800-735-3853
Fax: 314-231-5074
www.dukemfg.com