

# Electric Griddles

## OPERATING/INSTALLATION INSTRUCTIONS

### CAUTION

INSPECT CONTENTS IMMEDIATELY AND FILE CLAIM WITH DELIVERING CARRIER FOR ANY DAMAGE.

**SAVE YOUR BOX AND ALL PACKING MATERIALS.**  
YOU ARE RESPONSIBLE FOR DAMAGE TO YOUR UNIT IF RETURNED IMPROPERLY PACKED.

This Eagle Electric Griddle is equipped for the voltage indicated on the nameplate mounted on the rear of the unit. This griddle is designed for use on alternating current (AC) only.

### INSTALLATION

The installation of the electric griddle must conform to the  
**NATIONAL ELECTRIC CODE AND ALL  
LOCAL ELECTRIC CODES AND ORDINANCES AND THE  
LOCAL ELECTRIC COMPANY RULES AND REGULATIONS**

For your protection we recommend that a qualified electrician install this griddle. They should be familiar with electrical installations and all electrical codes.

Proper connections and power supply are essential for efficient performance.

The external wiring should be in conduit or an approved type of flexible cable suitable for operation at temperature indicated at the conduit hole, and a proper size to carry the load.

The supply circuit should be properly fused and equipped with a means of disconnecting, as required by local electrical code.

*THE BODY OF THE GRIDDLE SHOULD BE GROUNDED. (DO NOT GROUND TO A GAS SUPPLY LINE)*

#### 1 Power Supply

Remove the junction box cover on rear of griddle to expose the wire connections. Use one of the holes furnished for attaching the conduit with proper size clamp.

All wires must be spliced or joined as to be electrically or mechanically secure and be covered with insulation equal to that of the wire. Loose or improper connections may result in arcing, which in turn can cause a fire.

#### 2 Feet

Install feet by screwing each foot into the threaded openings on the bottom of the griddle. Failure to use feet will void warranty and could cause unsafe conditions.

#### 3 Leveling

Level unit by adjusting the four feet and tighten securely. The adjustable feet have an adjustment of one inch for line-up with other Eagle counter top lines. Check the feet every 60 days to assure that they are tight.



*Profit from the Eagle Advantage™*

EG9809 Revised 07/02

# OPERATING INSTRUCTIONS

Before operating griddle, it should be checked to see that it is sitting level. Adjust the feet if necessary to level the griddle.

## 1 Season the Surface

Clean the griddle surface thoroughly. After the griddle has been thoroughly cleaned, it should be seasoned to prevent food from sticking. Before using and after each thorough scouring, season the griddle by heating surface in the following manner:

1. Turn the temperature control dials to 350° degrees F.
2. Using a clean cloth, not a spatula, spread a thin film of cooking oil or fat over the griddle cooking surface. This film should remain on the hot griddle for half an hour.
3. Remove the excess fat and wipe clean.  
(CAUTION: GRIDDLE SURFACE WILL BE HOT.)
4. Apply another film of cooking oil over the hot cooking area for another half hour and again remove the excess fat and wipe clean. The griddle surface will be ready for use.

**Even with careful seasoning, food may stick to the griddle cooking surface until griddle plate is "broken in".**

## 2 Temperature Control

The temperature controls are combination "on/off" switches and thermostats. Your griddle is equipped with one thermostat per foot of cooking surface length. They operate independently of one another allowing different foot sections of the griddle to be operated at different temperatures. Each thermostat controls the section of the griddle above it.

## 3 Cooking

Set the thermostat dial knob at the desired temperature. After a short pre-heating period, the thermostat will automatically maintain the selected temperature. When the set temperature is reached, the signal light will go off.

# MAINTENANCE

It takes very little time and effort to keep the griddle attractive and performing at top efficiency. If grease is permitted to accumulate, it will form a gummy cake and then carbonize into a hard substance which is extremely difficult to remove. To prevent this condition please follow the cleaning steps below.

## 1 Scraping

After each use, scrape the griddle with a scraper or a flexible spatula to remove excess fat and food. A grease drawer is provided for the scrapings. If there is an accumulation of burned fat and food, the griddle should be thoroughly scoured and re-seasoned. Use pumice or griddle stone, while the griddle is warm, to remove excess fat and food. Do not use steel wool because of the danger of steel slivers getting into the food.

## 2 Body

Daily, use a clean cloth and a non-abrasive cleaner to clean the stainless steel body of the griddle. Wipe the polished front with a soft cloth.

## 3 Grease Drawer

At least once a day, remove the grease drawer and wash. If the grease drawer is permitted to fill too high, the excess grease will run out of overflow hole at the front of the drawer. The drawer is removed by pulling forward.

USE CAUTION WHEN FILLED WITH HOT GREASE

## 4 Controls

Unit should be turned off when not in use. It is recommended that the unit be disconnected from power supply by shutting off power disconnect switch.

# TROUBLE SHOOTING

Trouble	Cause	Remedy
Griddle will not heat	a. Fuse or breaker blown. b. Power line disconnected. c. Plug disconnected.	Replace fuse or reset breaker. Reset disconnect switch. Connect.
One section will not heat	a. Thermostat not turned on. b. Possible defective thermostat. c. Possible defective heating element.	Adjust to temperature. Call authorized service center. Call authorized service center.
Center Cold	a. Possible defective center element.	Call authorized service center
Griddle surface too hot	a. Cooking unevenly on griddle. b. Possible defective thermostat.	Space out food uniformly on griddle. Call authorized service center.
Food sticking	a. Grease or food particles accumulated on surface. b. Not seasoned.	See maintenance section. See maintenance section.
Food runs to one side	a. Not level.	See leveling instructions.

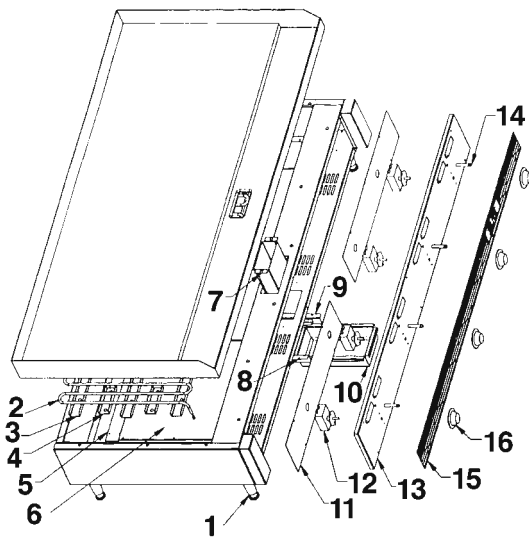

ref #	description	24" unit	part #'s 36" unit	48" unit
1	adjustable leg		310302	
2	heater		322149	
3	heater support		322131	
4	t-stat bulb sup't		323949	
5	bottom panel mount	324903	324918	323942
6	bottom panel	324891	324905	322727
7	grease chute		322736	
8	grease drawer bracket-LH		322731	
9	grease drawer bracket-RH		322732	
10	grease drawer		322730	
11	inner front panel	324902	324911/324915	323945
12	thermostat		320055	
13	control panel	324985	324916	322748
14	indicator light		302353	
15	"RED HOTS" label	326123	326124	326125
16	control knob		303089	
N/A	junction box cover		323950	
N/A	j-box nipple chase		310371	
N/A	lock nut for above		310372	

# WIRING DIAGRAMS

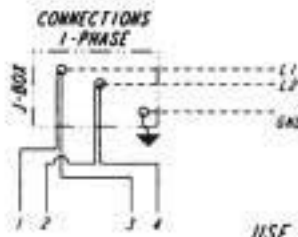
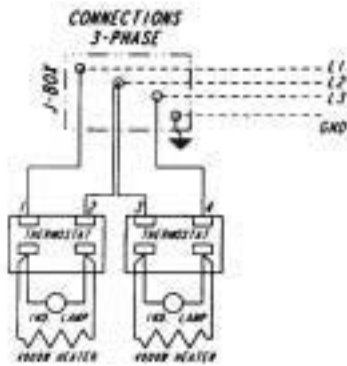

USE COPPER CONDUCTORS ONLY  
SUITABLE FOR AT LEAST 90° C

FIELD WIRING - FOR POWER SUPPLY USE ONLY							
	208V 3Ø 6000W		240V 3Ø 8000W		208V 1Ø		240V 1Ø
	L1	L2	L3	L1	L2	L3	
AMPS	14.5	29	14.5	17	33	17	29
FEED SIZE	12	8	12	10	8	10	8

MODEL: EGH-24

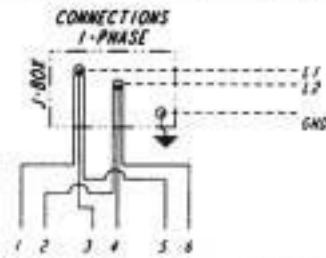
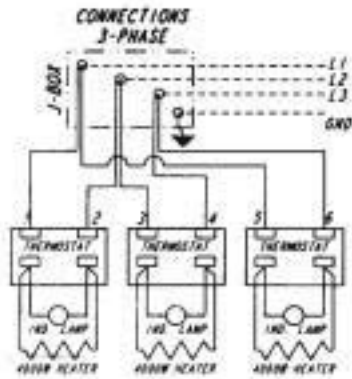

USE COPPER CONDUCTORS ONLY  
SUITABLE FOR AT LEAST 90° C

FIELD WIRING - FOR POWER SUPPLY USE ONLY							
	208V 3Ø 9000W		240V 3Ø 12000W		208V 1Ø		240V 1Ø
	L1	L2	L3	L1	L2	L3	
AMPS	29	29	29	36	36	36	43
FEED SIZE	8	8	8	8	8	8	6

MODEL: EGH-36

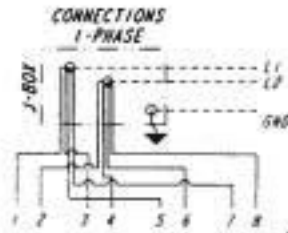
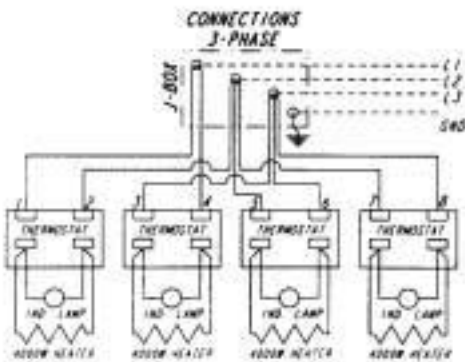

USE COPPER CONDUCTORS ONLY  
SUITABLE FOR AT LEAST 90° C

FIELD WIRING - FOR POWER SUPPLY USE ONLY							
	208V 3Ø 12000W		240V 3Ø 15000W		208V 1Ø		240V 1Ø
	L1	L2	L3	L1	L2	L3	
AMPS	29	43	43	33	50	50	50
FEED SIZE	8	6	6	8	6	6	4

MODEL: EGH-48



Profit from the Eagle Advantage™

EG9809 Revised 07/02

• 100 Industrial Boulevard, Clayton, Delaware 19938-8903 U.S.A. • [www.eaglegrp.com](http://www.eaglegrp.com)  
 • Phone: 302/653-3000 • (Fdsrv) 800/441-8440 • (MHC/Retail) 800/637-5100 • Fax: 302/653-2065 or 302/653-3036

Eagle Foodservice Equipment, Eagle MHC, Level-Lok Inc., and SpecFAB are divisions of Eagle Group. ©2002 by the Eagle Group