

Control de Documento**A. Revisiones y aprobaciones del documento.**

Actividad	Puesto	Nombre	Fecha
Elaboró:	Ing. De Producto	Raúl Santiago	10/07/15
Revisó:	Dir. Calidad y Producto	Alejandro Montelongo	10/07/15
Aprobó:	Dir. Calidad y Producto	Alejandro Montelongo	10/07/15

B. Descripción de cambios

Fecha	Rev.	Solicitante	Naturaleza del cambio
28/01/16	A	Daniel Perez	Revisar y Actulizar/ Chek and Update

NO IMPRIMIR 1^{er} HOJA "CONTROL DOCUMENTAL"IMPRIMIR APARTIR DE LA 2^{DA} HOJA

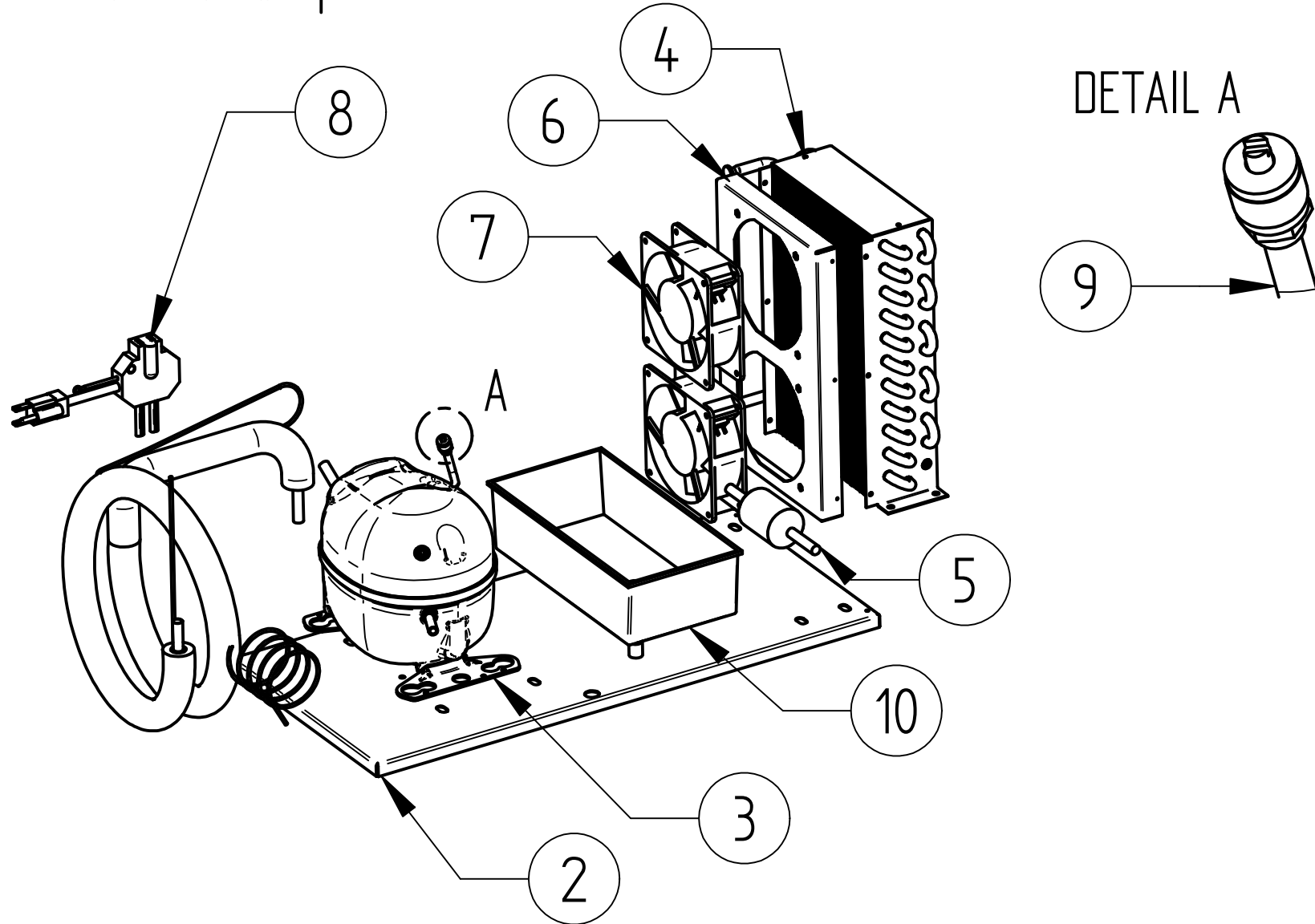

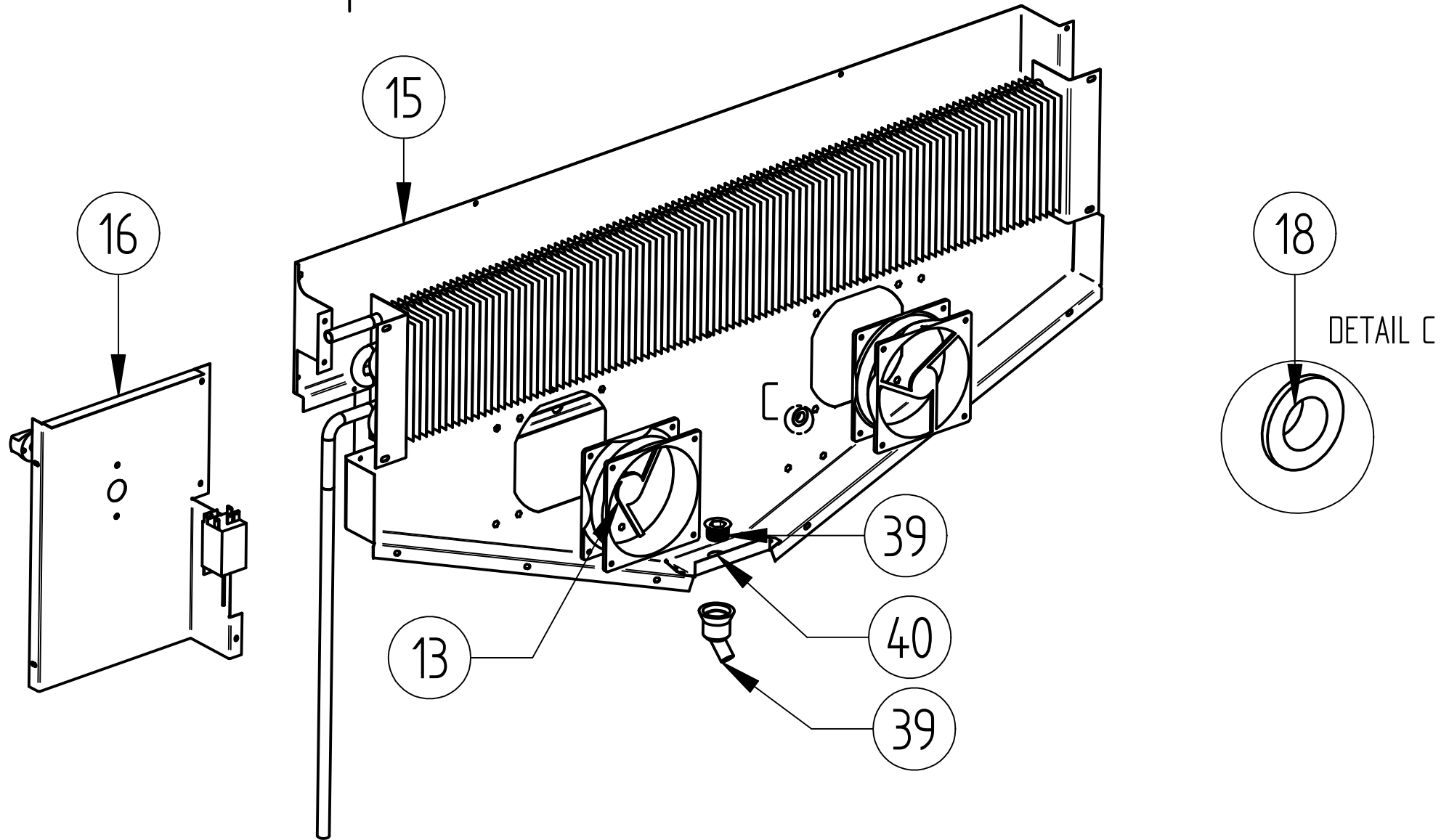

FAGOR



DESPIECE

PARTS BREAKDOWNS

DETAIL D

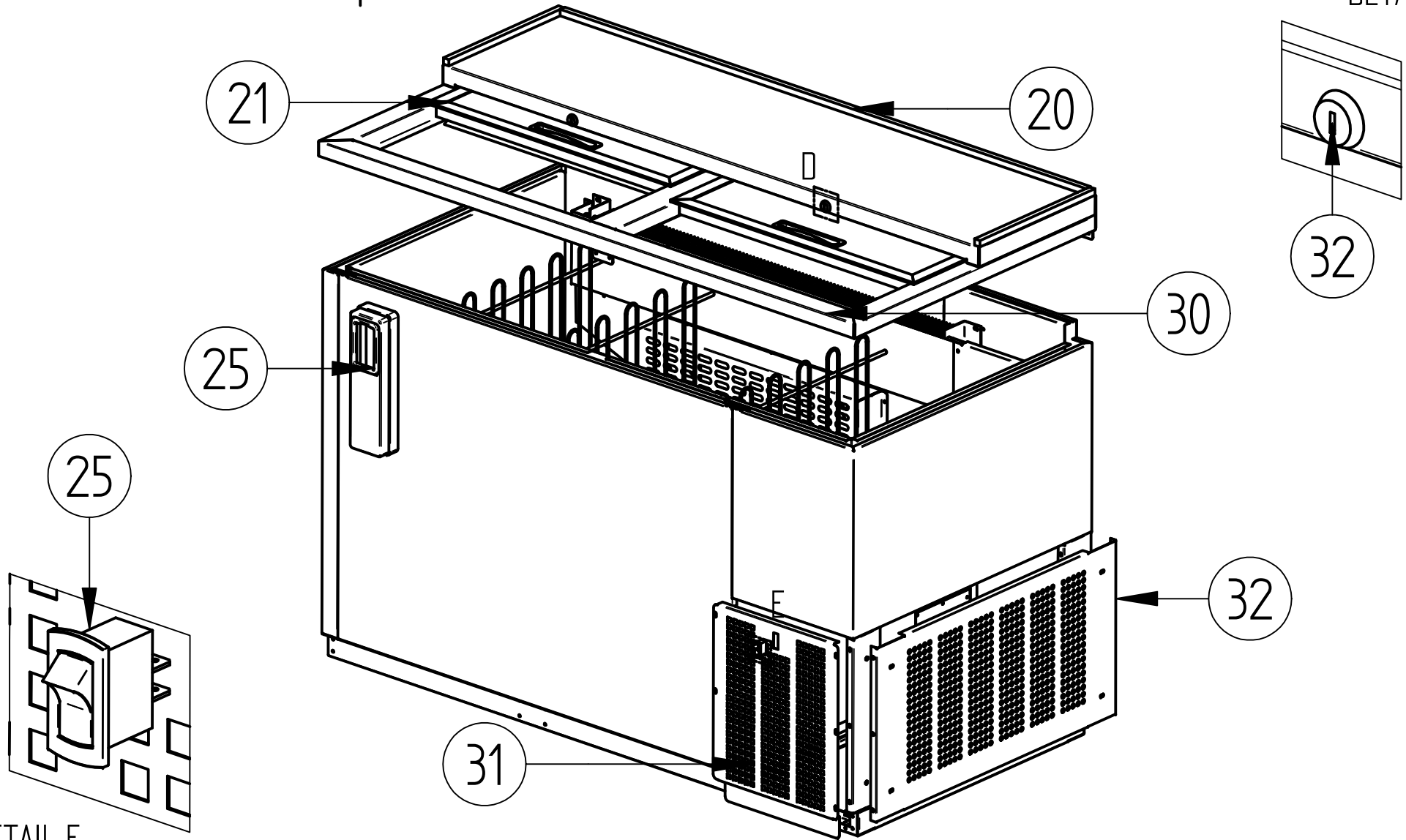

DETAIL E

FAGOR



DESPIECE

PARTS BREAKDOWNS

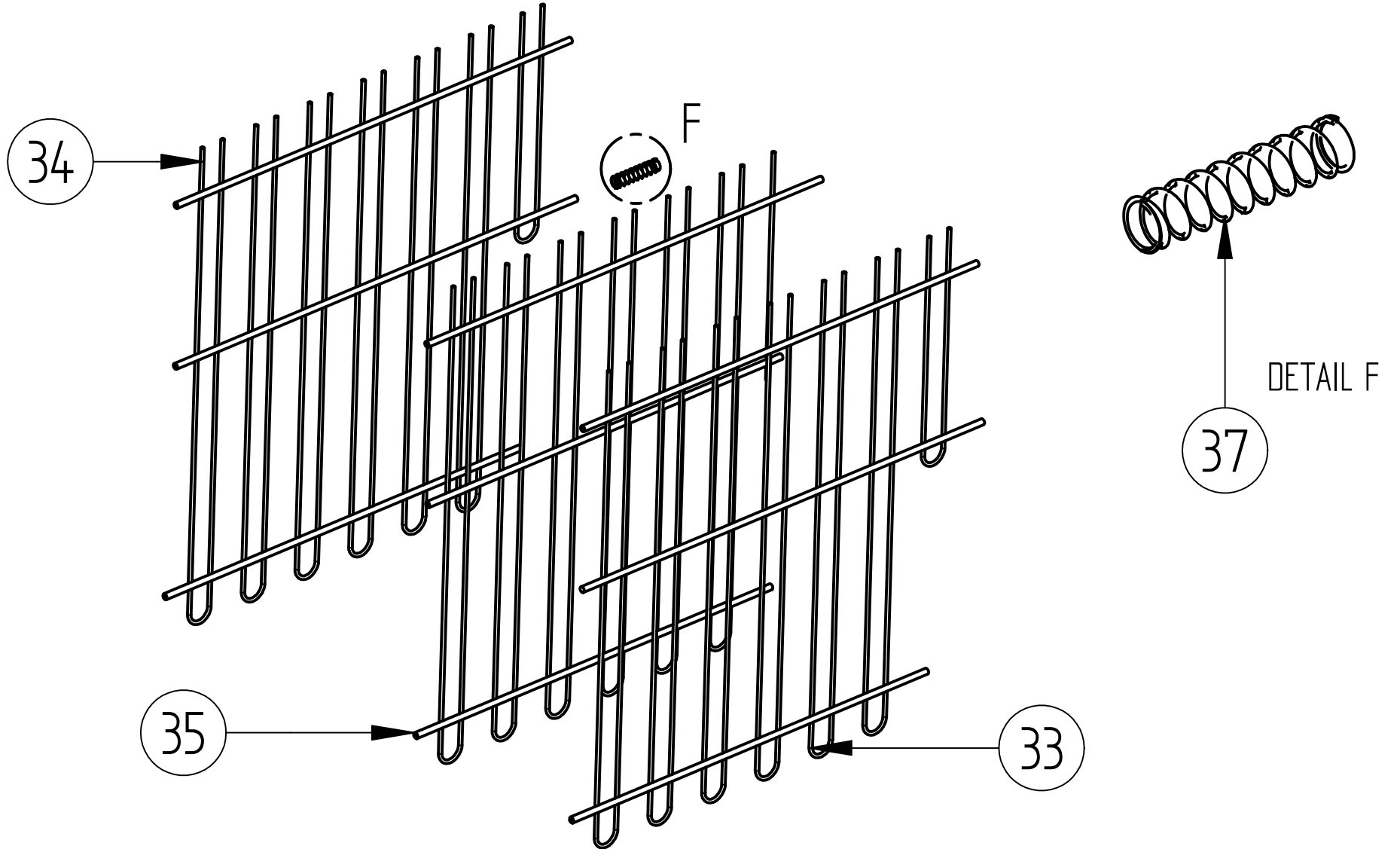

FAGOR



DESPIECE

PARTS BREAKDOWNS

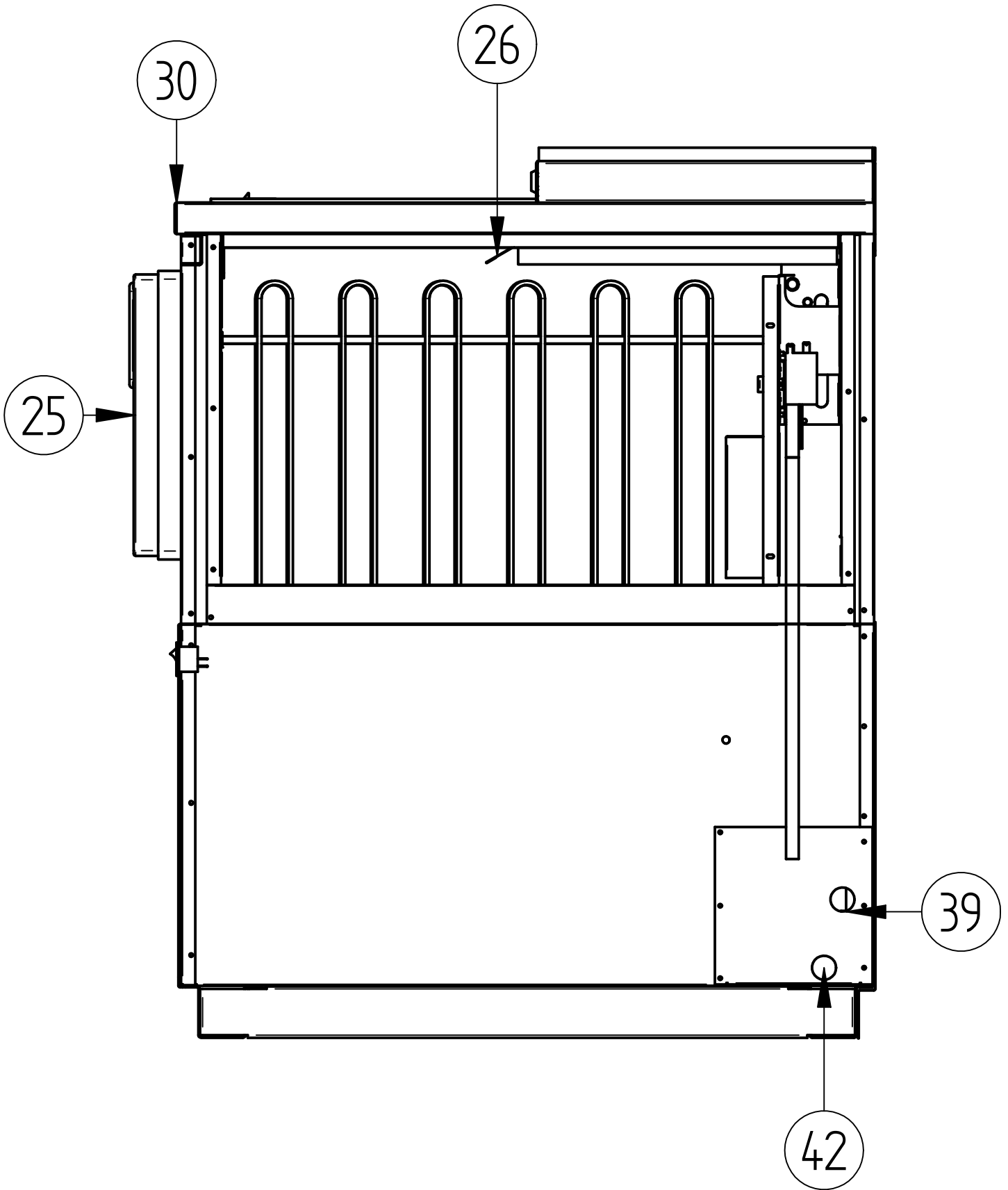



# ITEM	CODE CÓDIGO	DESCRIPTION	DESCRIPCIÓN	FBC-50	FBC-50-S	FBC-65	FBC-65 S	FBC-79	FBC-95	FBC-95 S
Condensing Units / Unidades de Condensación										
	M17301M0030	CONDENSING UNIT	UNIDAD CONDENSACION	1	1					
2	M10917M0800	DECK	BANCADA	1	1					
3	602101M0095	COMPRESSOR 115V	COMPRESOR 115V	1	1					
	602101M0101	START KIT	KIT ARRANQUE	1	1					
4	602902M0009	CONDENSER	CONDENSADOR	1	1					
5	604701M0005	FILTER	FILTRO	1	1					
6	M10917M0222	FAN SUPPORT	SOPORTE VENTILADOR	1	1					
7	6021050020	FAN	VENTILADOR	2	2					
8	602139M0008	POWER CORD (SPIDER HUB)	CORDON TOMA CORRIENTE	1	1					
9	6021310003	SERVICE VALVE	VALVULA OBUS	1	1					
10	6003010023	AUTOMATIC DRAIN PAN	BANDEJA EVAPORACION	1	1					
	M17301M0023	CONDENSING UNIT	UNIDAD CONDENSACION			1	1	1	1	1
2	M10917M0800	DECK	BANCADA			1	1	1	1	1
3	602101M0096	COMPRESSOR 115V	COMPRESOR 115V			1	1	1	1	1
	602101M0103	START KIT	KIT ARRANQUE			1	1	1	1	1
4	602902M0009	CONDENSER	CONDENSADOR			1	1	1	1	1
5	604701M0005	FILTER	FILTRO			1	1	1	1	1
6	M10917M0222	FAN SUPPORT	SOPORTE VENTILADOR			1	1	1	1	1
7	6021050020	FAN	VENTILADOR			2	2	2	2	2
8	602139M0008	POWER CORD (SPIDER HUB)	CORDON TOMA CORRIENTE			1	1	1	1	1
9	6021310003	SERVICE VALVE	VALVULA OBUS			1	1	1	1	1
10	6003010023	AUTOMATIC DRAIN PAN	BANDEJA EVAPORACION			1	1	1	1	1



# ITEM	CODE CÓDIGO	DESCRIPTION	DESCRIPCIÓN	FBC-50	FBC-50-S	FBC-65	FBC-65 S	FBC-79	FBC-95	FBC-95 S
Evaporation Units / Unidades de Evaporación										
M17101M0048				EVAPORATION UNIT	UNIDAD EVAPORACION	1	1			
11	602901M0002	EVAPORATOR COIL	EVAPORADOR	1	1					
12	M10917M0317	FAN GRID	REJILLA VENTILADOR	1	1					
13	6021050020	FAN	VENTILADOR	2	2					
14	M10917M0386	EVAPORATION TRAY	BANDEJA EVAPORACION	1	1					
15	M10917M0385	EVAPORATOR PROTECTOR	PROTECTOR EVAPORADOR	1	1					
16	M10917M0387	CONTROLLER SUPPORT	SOPORTE CONTROL	1	1					
17	M10917M0318	GRID SUPPORT	SOPORTE PARRILLA	1	1					
18	6003010082	GROMMET	PASAHILOS GOMAR	2	2					
M17101M0045				EVAPORATION UNIT	UNIDAD EVAPORACION		1	1		
11	602901M0013	EVAPORATOR COIL	EVAPORADOR			1	1			
12	M10917M0317	FAN GRID	REJILLA VENTILADOR			1	1			
13	6021050020	FAN	VENTILADOR			2	2			
14	M10917M0319	EVAPORATION TRAY	BANDEJA EVAPORACION			1	1			
15	M10917M0315	EVAPORATOR PROTECTOR	PROTECTOR EVAPORADOR			1	1			
16	M10917M0350	CONTROLLER SUPPORT	SOPORTE CONTROL			1	1			
17	M10917M0318	GRID SUPPORT	SOPORTE PARRILLA			1	1			
18	6003010082	GROMMET	PASAHILOS GOMAR			2	2			
M17101M0071				EVAPORATION UNIT	UNIDAD EVAPORACION				1	
11	602901M0013	EVAPORATOR COIL	EVAPORADOR						1	
12	M10917M0317	FAN GRID	REJILLA VENTILADOR						1	
13	6021050020	FAN	VENTILADOR						2	
14	M10917M0319	EVAPORATION TRAY	BANDEJA EVAPORACION						1	
15	M10917M0315	EVAPORATOR PROTECTOR	PROTECTOR EVAPORADOR						1	
16	M10917M0316	CONTROLLER SUPPORT	SOPORTE CONTROL						1	
17	M10917M0318	GRID SUPPORT	SOPORTE PARRILLA						1	
18	6003010082	GROMMET	PASAHILOS GOMAR						2	
19	M10917M0680	HOSE COVER	CONDUCTO TUBERIA						1	
M17101M0043				EVAPORATION UNIT	UNIDAD EVAPORACION				1	1
11	602901M0013	EVAPORATOR COIL	EVAPORADOR						1	1
12	M10917M0317	FAN GRID	REJILLA VENTILADOR						1	1
13	6021050020	FAN	VENTILADOR						2	2
14	M10917M0319	EVAPORATION TRAY	BANDEJA EVAPORACION						1	1
15	M10917M0315	EVAPORATOR PROTECTOR	PROTECTOR EVAPORADOR						1	1
16	M10917M0316	CONTROLLER SUPPORT	SOPORTE CONTROL						1	1
17	M10917M0318	GRID SUPPORT	SOPORTE PARRILLA						1	1
18	6003010082	GROMMET	PASAHILOS GOMAR						2	2
19	M10917M0349	HOSE COVER	CONDUCTO TUBERIA						1	1



# ITEM	CODE CÓDIGO	DESCRIPTION	DESCRIPCIÓN	FBC-50	FBC-50-S	FBC-65	FBC-65 S	FBC-79	FBC-95	FBC-95 S
Top / Encimera										
20	M18101M0300	TOP 50"	ENCIEMRA 50"	1	1					
	M18101M0315	TOP 65"	ENCIEMRA 65"			1	1			
	M18101M0322	TOP 79"	ENCIEMRA 79"					1		
	M18101M0302	TOP 95"	ENCIEMRA 95"						1	1
Doors & Others / Puertas & Otros										
21	M16901M0254	FBC DOOR 50"	PUERTA BC 50"	2	2					
	M16901M0275	FBC DOOR 65"	PUERTA BC 65"			2	2			
	M16901M0281	FBC DOOR 79"	PUERTA BC 79"					3		
	M16901M0256	FBC DOOR 95"	PUERTA BC 95"						3	3
Controllers & Other / Controles & Otros										
	M10505M0007	CONTROL RANCO KIT	CONTROL RANCO KIT	1	1	1	1	1	1	1
22	602109M0006	RANCO CONTROLLER	CONTROL RANCO	1	1	1	1	1	1	1
23	602135M0013	RANCO ACCESORIES	ACCESORIOS RANCO	1	1	1	1	1	1	1
24	600301M0074	RANCO KNOB	PERILLA C. RANCO	1	1	1	1	1	1	1
Accesories/Accesorios										
25	603305M0014	CAP CATCHER	DESTAPADOR	1	1	1	1	1	1	1
	602129M0047	LED LAMP 0.98M	LAMPARA LED 0.98M	1	1					
26	602129M0045	LED LAMP 1.2M	LAMPARA LED 1.2M			1	1			
	602129M0046	LED LAMP 1.4M	LAMPARA LED 1.4M					1	1	1
27	602129M0023	DRIVER	DRIVER LED	1	1	1	1	1	1	1
28	6021130002	LIGHT SWITCH	INTERRUPTOR ILUMINACION	1	1	1	1	1	1	1
29	603301M0056	LOCK	CERRADURA	2	2	2	2	3	3	3
	M10913M0611	LOCK PIN	PASADOR CERRADURA	2	2	2	2	3	3	3
30	603317M0002	FAGOR PLATE	PLACA FAGOR	1	1	1	1	1	1	1
Panels /Rejillas										
31	M10917M0622	FRONTAL PANEL	PANEL FRONTAL	1		1		1	1	
	M10913M0614	SS FRONTAL PANEL	PANEL FRONTAL INOX		1		1			1
32	M10917M0567	SIDE PANEL	PANEL ALTERAL	1		1		1	1	
	M10913M0613	SS SIDE PANEL	PANEL LATERAL INOX		1		1			1
Grids /Parrillas										
33	602701M0023	RIGHT GRID	PARRILLA DERECHA	2	2	3	3	4	4	4
34	602701M0024	LEFT GRID	PARRILLA IZQUIERDA					2	2	2
35	602701M0025	CENTRAL GRID	PARRILLA CENTRAL	1	1	1	1	1	1	1
36	600301M0030	PLASTIC GROMMET	PASAHILOS PLASTICO	30	30	45	45	60	72	72
37	602529M0011	SPRING	RESORTE	3	3	4	4	7	7	7
Drain /Drenaje										
38	600717M0087	DRAIN HOSE	MANGUERA DESAGUE	2.5	2.5	2.6	2.6	2.9	2.9	2.9
39	600717M0033	COUPLE FITTING	COPEL ESPIGA DOBLE	1	1	1	1	1	1	1
40	604305M0002	DRAIN	DESAGUE	2	2	2	2	2	2	2
41	6003010051	PLASTIC SEAL	JUNTA PLASTICA	2	2	2	2	2	2	2
42	600305M0132	GROMMET	MEMBRANA	2	2	2	2	2	2	2



PARTS BREAKDOWNS

# ITEM	CODE CÓDIGO	DESCRIPTION	DESCRIPCIÓN	FBC-50	FBC-50-S	FBC-95
Condensing Units / Unidades de Condensación						
	M17301M0040	CONDENSING UNIT	UNIDAD CONDENSACION	1	1	
2	M10917M0283	DECK	BANCADA	1	1	
3	602101M0099	COMPRESSOR 220V	COMPRESOR 220V	1	1	
	602101M0102	START KIT	KIT ARRANQUE	1	1	
4	602902M0009	CONDENSER	CONDENSADOR	1	1	
5	604701M0005	FILTER	FILTRO	1	1	
6	M10917M0222	FAN SUPPORT	SOPORTE VENTILADOR	1	1	
7	6021050008	FAN	VENTILADOR	2	2	
8	602139M0008	POWER CORD (SPIDER HUB)	CORDON TOMA CORRIENTE	1	1	
9	6021310003	SERVICE VALVE	VALVULA OBUS	1	1	
10	6003010023	AUTOMATIC DRAIN PAN	BANDEJA EVAPORACION	1	1	
	M17301M0028	CONDENSING UNIT	UNIDAD CONDENSACION			1
2	M10917M0283	DECK	BANCADA			1
3	602101M0097	COMPRESSOR 220V	COMPRESOR 220V			1
	602101M0104	START KIT	KIT ARRANQUE			1
4	602902M0009	CONDENSER	CONDENSADOR			1
5	604701M0005	FILTER	FILTRO			1
6	M10917M0222	FAN SUPPORT	SOPORTE VENTILADOR			1
7	6021050008	FAN	VENTILADOR			2
8	602139M0008	POWER CORD (SPIDER HUB)	CORDON TOMA CORRIENTE			1
9	6021310003	SERVICE VALVE	VALVULA OBUS			1
10	6003010023	AUTOMATIC DRAIN PAN	BANDEJA EVAPORACION			1
Evaporation Units / Unidades de Evaporación						
	M17101M0059	EVAPORATION UNIT	UNIDAD EVAPORACION	1	1	
11	602901M0002	EVAPORATOR COIL	EVAPORADOR	1	1	
12	M10917M0317	FAN GRID	REJILLA VENTILADOR	1	1	
13	6021050008	FAN	VENTILADOR	2	2	
14	M10917M0386	EVAPORATION TRAY	BANDEJA EVAPORACION	1	1	
15	M10917M0385	EVAPORATOR PROTECTOR	PROTECTOR EVAPORADOR	1	1	
16	M10917M0387	CONTROLLER SUPPORT	SOPORTE CONTROL	1	1	
17	M10917M0318	GRID SUPPORT	SOPORTE PARRILLA	1	1	
18	6003010082	GROMMET	PASAHILOS GOMAR	1	1	
	M17101M0067	EVAPORATION UNIT	UNIDAD EVAPORACION			1
11	602901M0013	EVAPORATOR COIL	EVAPORADOR			1
12	M10917M0317	FAN GRID	REJILLA VENTILADOR			1
13	6021050008	FAN	VENTILADOR			2
14	M10917M0319	EVAPORATION TRAY	BANDEJA EVAPORACION			1
15	M10917M0315	EVAPORATOR PROTECTOR	PROTECTOR EVAPORADOR			1
16	M10917M0316	CONTROLLER SUPPORT	SOPORTE CONTROL			1
17	M10917M0318	GRID SUPPORT	SOPORTE PARRILLA			1
18	6003010082	GROMMET	PASAHILOS GOMAR			1
19	M10917M0349	HOSE COVER	CONDUCTO TUBERIA			1



PARTS BREAKDOWNS

# ITEM	CODE CÓDIGO	DESCRIPTION	DESCRIPCIÓN	FBC-50	FBC-50-S	FBC-95
Top / Encimera						
20	M18101M0300	TOP 50"	ENCIEMRA 50"	1	1	
	M18101M0302	TOP 95"	ENCIEMRA 95"			1
Doors & Others / Puertas & Otros						
21	M16901M0254	FBC DOOR 50"	PUERTA BC 50"	2	2	
	M16901M0275	FBC DOOR 65"	PUERTA BC 65"			
	M16901M0281	FBC DOOR 79"	PUERTA BC 79"			
	M16901M0256	FBC DOOR 95"	PUERTA BC 95"			3
Controllers & Other / Controles & Otros						
	M10505M0007	CONTROL RANCO KIT	CONTROL RANCO KIT	1	1	1
22	602109M0006	RANCO CONTROLLER	CONTROL RANCO	1	1	1
23	602135M0013	RANCO ACCESORIES	ACCESORIOS RANCO	1	1	1
24	600301M0074	RANCO KNOB	PERILLA C. RANCO	1	1	1
Accesories/Acesorios						
25	603305M0014	CAP CATCHER	DESTAPADOR	1	1	1
26	602129M0047	LED LAMP 0.98M	LAMPARA LED 0.98M	1	1	
	602129M0046	LED LAMP 1.4M	LAMPARA LED 1.4M			1
27	602129M0023	DRIVER	DRIVER LED	1	1	1
28	6021130002	LIGHT SWITCH	INTERRUPTOR ILUMINACION	1	1	1
29	603301M0056	LOCK	CERRADURA	2	2	3
	M10913M0611	LOCK PIN	PASADOR CERRADURA	2	2	3
30	603317M0002	FAGOR PLATE	PLACA FAGOR	1	1	1
Panels /Rejillas						
31	M10917M0622	FRONTAL PANEL	PANEL FRONTAL	1		1
	M10913M0614	SS FRONTAL PANEL	PANEL FRONTAL INOX		1	
32	M10917M0567	SIDE PANEL	PANEL ALTERAL	1		1
	M10913M0613	SS SIDE PANEL	PANEL LATERAL INOX		1	
Grids /Parrillas						
33	602701M0023	RIGHT GRID	PARRILLA DERECHA	2	2	4
34	602701M0024	LEFT GRID	PARRILLA IZQUIERDA			2
35	602701M0025	CENTRAL GRID	PARRILLA CENTRAL	1	1	1
36	600301M0030	PLASTIC GROMMET	PASAHILOS PLASTICO	30	30	72
37	602529M0011	SPRING	RESORTE	3	3	7
Drain /Drenaje						
38	600717M0087	DRAIN HOSE	MANGUERA DESAGUE	2.5	2.5	2.9
39	600717M0033	COUPLE FITTING	COPL E SPIGA DOBLE	1	1	1
40	604305M0002	DRAIN	DESAGUE	2	2	2
41	6003010051	PLASTIC SEAL	JUNTA PLASTICA	2	2	2
42	600305M0132	GROMMET	MEMBRANA	2	2	2

FAGOR



CUSTOMER SERVICE

Fagor Commercial, Inc.
13105NW 47thAve
Miami, FL 33054
Tel:(305) 7790170
Fax:(305)7790173
1-866-463-2467
www.Fagorcommercial.com

Circuito Exportación N° 201
Parque Industrial Tres Naciones
San Luis Potosí, S.L.P. México
C.P. 78395
Planta S.L.P.: + 52 (444) 137 0500
México D.F.: + 52 (55) 5082 5825

SERVICIO TECNICO