

Control de Documento**A. Revisiones y aprobaciones del documento.**

Actividad	Puesto	Nombre	Fecha
Elaboró:	Ing. De Producto	Raúl Santiago	09/07/15
Revisó:	Dir. Calidad y Producto	Alejandro Montelongo	09/07/15
Aprobó:	Dir. Calidad y Producto	Alejandro Montelongo	09/07/15

B. Descripción de cambios

Fecha	Rev.	Solicitante	Naturaleza del cambio

NO IMPRIMIR 1^{er} HOJA "CONTROL DOCUMENTAL"

IMPRIMIR APARTIR DE LA 2^{DA} HOJA

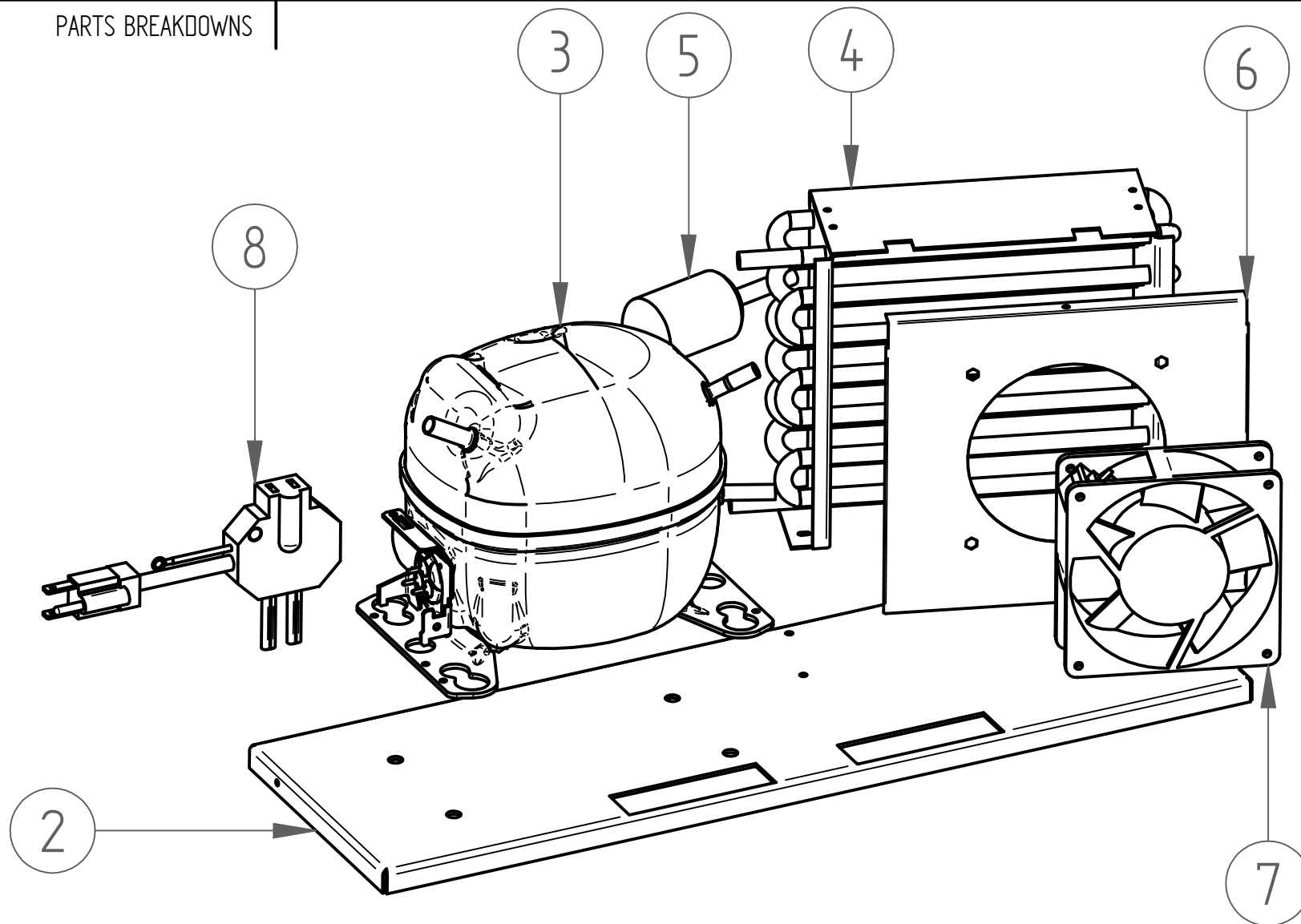



PARTS BREAKDOWNS

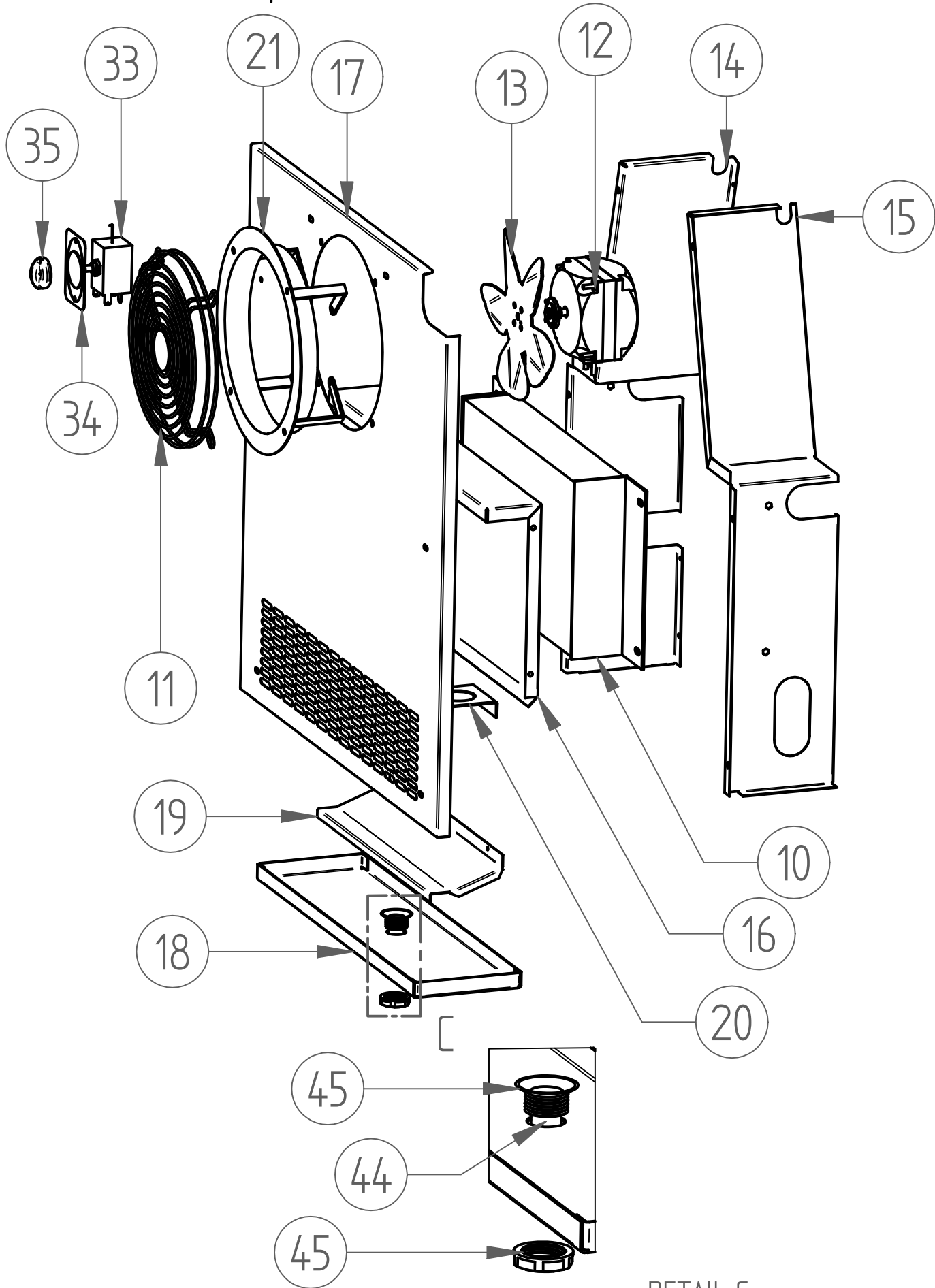

DETAIL C

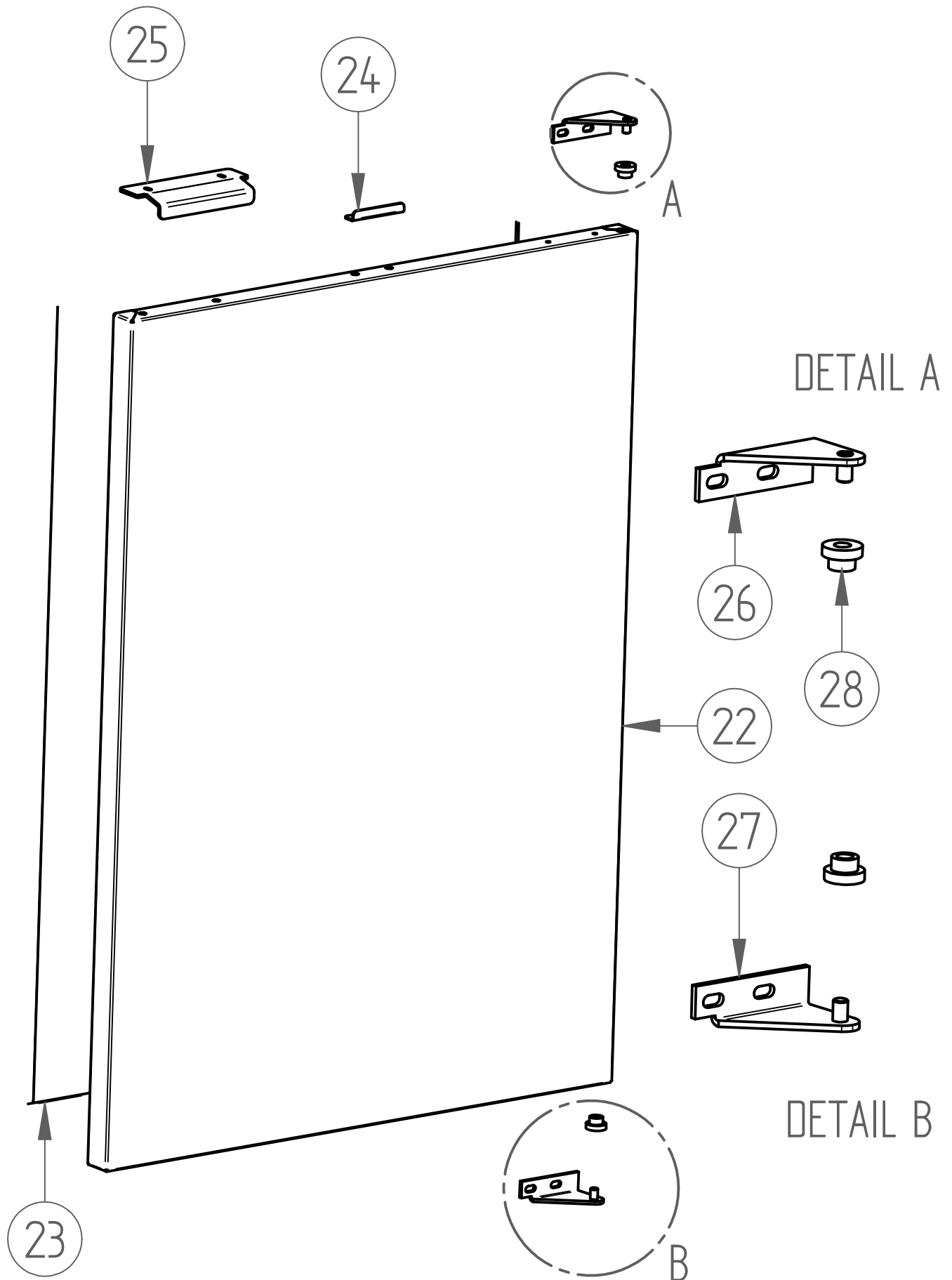

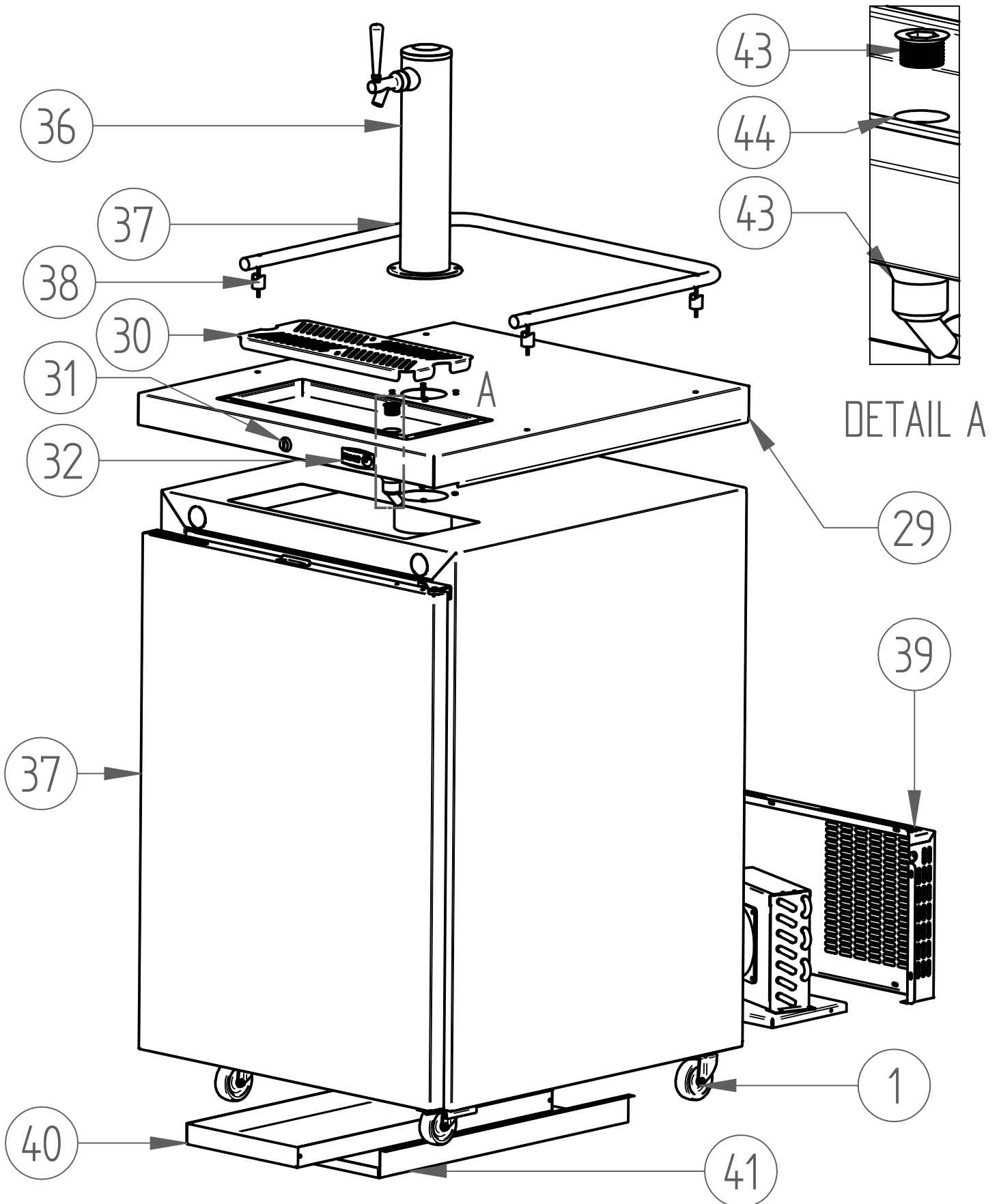

# ITEM	CODE CÓDIGO	DESCRIPTION	DESCRIPCIÓN	FDD-24	FDD-24 S
Castors & Legs / Ruedas & Tacones					
1	603313M0007	CASTER 2.5" W/BRAKE	RUEDA DELANTERA C/F Ø 2.5"	2	2
	603313M0006	CASTER 2.5" WO/ BRAKE	RUEDA DELANTERA S/F Ø 2.5"	2	2
Condensing Units / Unidades de Condensación					
	M17301M0024	CONDENSING UNIT	UNIDAD CONDENSACION	1	1
2	M10917M0163	DECK	BANCADA	1	1
3	602101M0073	COMPRESSOR 115V	COMPRESOR 115V	1	1
3	602101M0082	START KIT	KIT ARRANQUE	1	1
4	6029020023	CONDENSER	CONDENSADOR	1	1
5	604701M0002	FILTER	FILTRO	1	1
7	M10917M0210	FAN SUPPORT	SOPORTE VENTILADOR	1	1
8	6021050020	FAN	VENTILADOR	1	1
9	602139M0008	POWER CORD (SPIDER HUB)	CORDON TOMACORRIENTE	1	1
	6021310003	SERVICE VALVE	VALVULA OBUS	1	1
Evaporation Units / Unidades de Evaporación					
	M17101M0036	EVAPORATION UNIT	UNIDAD EVAPORACION	1	1
10	602901M0014	EVAPORATOR COIL	EVAPORADOR	1	1
11	602713M0001	FAN GRID	REJILLA VENTILADOR	1	1
12	602105M0001	FAN	VENTILADOR 5W	1	1
13	602105M0012	BLADE	ASPA PLASTICA 6.5"	1	1
14	M10917M0154	LEFT DEFLECTOR	DEFLECTOR IZQUIERDO	1	1
15	M10917M0156	RIGHT DEFLECTOR	DEFLECTOR DERECHO	1	1
16	M10917M0155	CENTRAL DEFLECTOR	DEFLECTOR CENTRAL	1	1
17	M10917M0157	EVAPORATOR COVER	CUBIERTA EVAPORADOR	1	1
18	600305M0100	EVAPORATION TRAY	BANDEJA EVAPORACION	1	1
19	M10917M0228	CURVED DEFLECTOR	DEFLECTOR CURVO	1	1
20	M10917M0468	HOSE SUPPORT	SOPORTE MANGUERA	1	1
21	600709M0017	FAN SUPPORT	ARO CONDUCTO METALICO	1	1
Doors & O thers / Puertas & Otros					
	M16901M0212	DOOR KIT	ENSAMBLE DE PUERTAS	1	
22	M10917M0530	DOOR	PUERTA	1	
23	604501M0007	GASKET	BURLETE	1	
24	603301M0168	LOCK STOP	TOPE CERRADURA	1	
25	603301M0155	BLACK HANDLE	JALADERA NEGRA	1	
	M16901M0226	SS DOOR KIT	ENSAMBLE DE PUERTAS INOX		1
22	M10913M0535	DOOR	PUERTA		1
23	604501M0007	GASKET	BURLETE		1
24	603301M0168	LOCK STOP	TOPE CERRADURA		1
25	603301M0155	SS HANDLE	JALADERA INOX		1
	M16909M0023	HINGE KIT	CONJUNTO BISAGRAS	1	1
26	603301M0106	BOTTOM HINGE	BISAGRA INFERIOR	1	1
27	603301M0107	TOP HINGE	BISAGRA SUPERIOR	1	1
28	600305M0133	NYLON SPACER	SEPARADOR PLASTICO	2	2

# ITEM	CODE CÓDIGO	DESCRIPTION	DESCRIPCIÓN	FDD-24	FDD-24 S
Top Panel /Encimera					
29	M18101M0120	TOP ASSEMBLY	ENCIMERA	1	1
30	M10901M0411	DRAIN TRAY	REJILLA ESCURRIMIENTO	1	1
31	603301M0056	LOCK	CERRADURA	1	1
32	603317M0002	FAGOR PLATE	SELLO FAGOR	1	1
Controllers & Other / Controles & Otros					
	M10505M0007	CONTROL RANCO KIT	CONTROL RANCO KIT	1	1
33	602109M0006	RANCO CONTROLLER	CONTROL RANCO	1	1
34	602135M0013	RANCO ACCESORIES	ACCESORIOS RANCO	1	1
35	600301M0074	RANCO KNOB	PERILLA C. RANCO	1	1
Accesories/Accesorios					
36	604313M0006	TOWER 1 FAUCET	TORRE 1 DISPARO	1	1
37	603305M0004	HANDRAIL	BARANDAL	1	1
38	603305M0005	SEPARATOR HANDRAIL	SEPARADORES BARANDAL	4	4
Panels /Rejillas					
39	M10917M0164	BACK PANEL	REJILLA POSTERIOR	1	
	M10913M0169	BACK PANEL	REJILLA POSTERIOR		1
Drain /Drenaje					
40	M10917M0171	DRAIN PAN	BANDEJA ESCURRIMIENTO	1	1
41	M10917M0175	DRAIN PAN SUPPORT	SOPORTE BANDEJA ESCURRIMIENTO	1	1
42	602301M0030	HEATSINK PAPER	PAPEL DISIPADOR DE HUMEDAD	1	1
43	604305M0002	DRAIN	DESAGUE	1	1
44	6003010051	PLASTIC SEAL	JUNTA PLASTICA	1	1
45	6003010034	EVAPORATION DRAIN	DESAGUE EVAPORACION	1	1



CUSTOMER SERVICE

Fagor Commercial, Inc.
13105NW 47thAve
Miami, FL. 33054
Tel:(305) 7790170
Fax:(305)7790173
1-866-463-2467
www.Fagorcommercial.com

Circuito Exportación N° 201
Parque Industrial Tres Naciones
San Luís Potosí, S.L.P. México
C.P. 78395
Planta S.L.P.: + 52 (444) 137 0500
México D.F.: + 52 (55) 5082 5825

SERVICIO TECNICO