

ONNERA GROUP	FORMATO	CLAVE:	FID-16
	DESPIECES	FECHA DE REVISIÓN:	17-Feb-2015
		NO. REVISIÓN:	A

Control de Documento

A. Revisiones y aprobaciones del documento.

Actividad	Puesto	Nombre	Fecha
Elaboró:	Ing. de Producto	Raúl Santiago	03/07/15
Revisó:	Dir. Calidad y Producto	Alejandro Montelongo	03/07/15
Aprobó:	Dir. Calidad y Producto	Alejandro Montelongo	03/07/15

B. Descripción de cambios

Fecha	Rev.	Solicitante	Naturaleza del cambio
15/12/15	A	Daniel Perez	Actualizar Motor Electronico, Resistencia Goteo e Imagen Desague 60° / Updated Electronical Fan, Heater & Fitting.

NO IMPRIMIR 1^{er} HOJA "CONTROL DOCUMENTAL"

IMPRIMIR APARTIR DE LA 2^{DA} HOJA

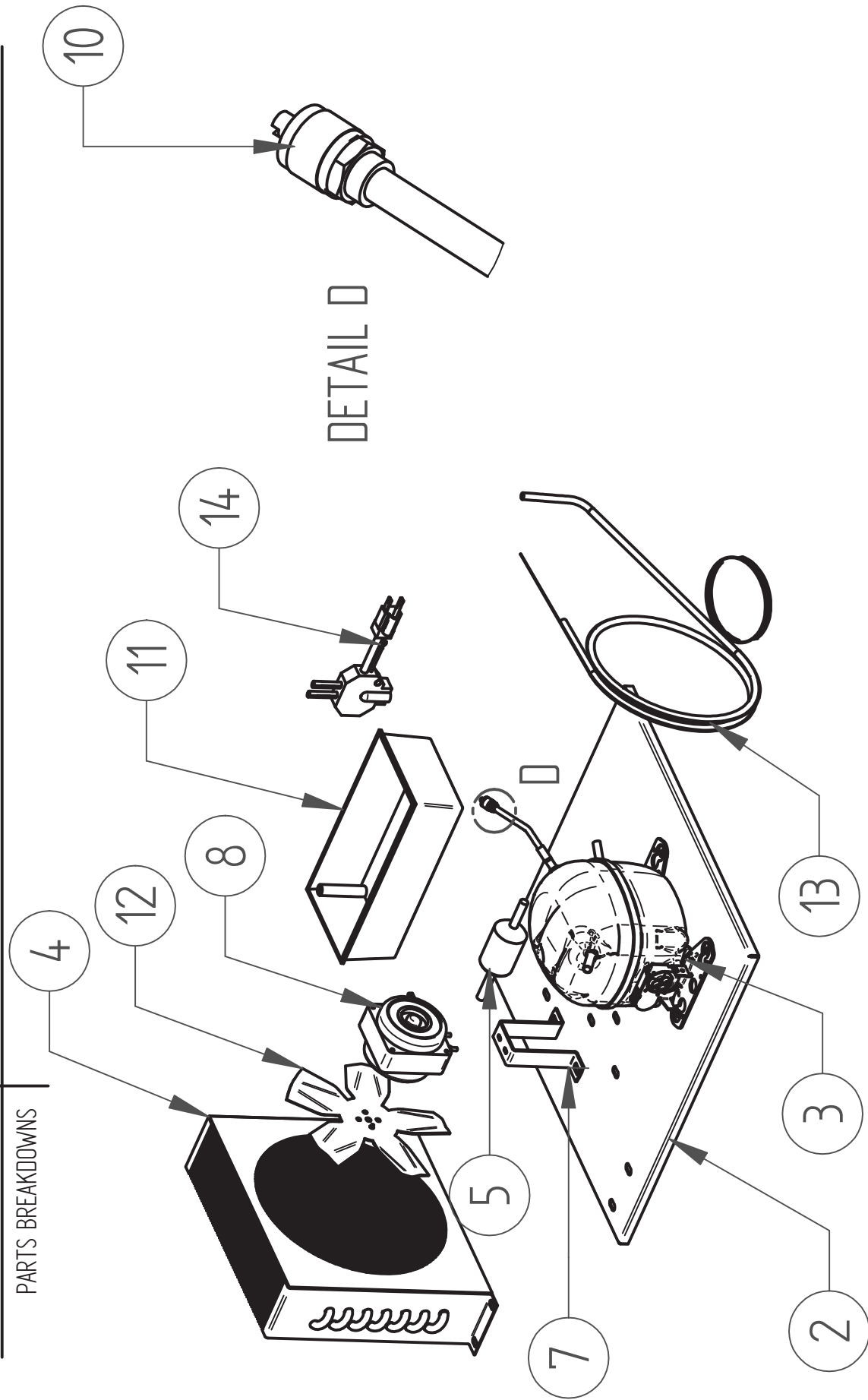

FAGOR



DESPIECE

PARTS BREAKDOWNS

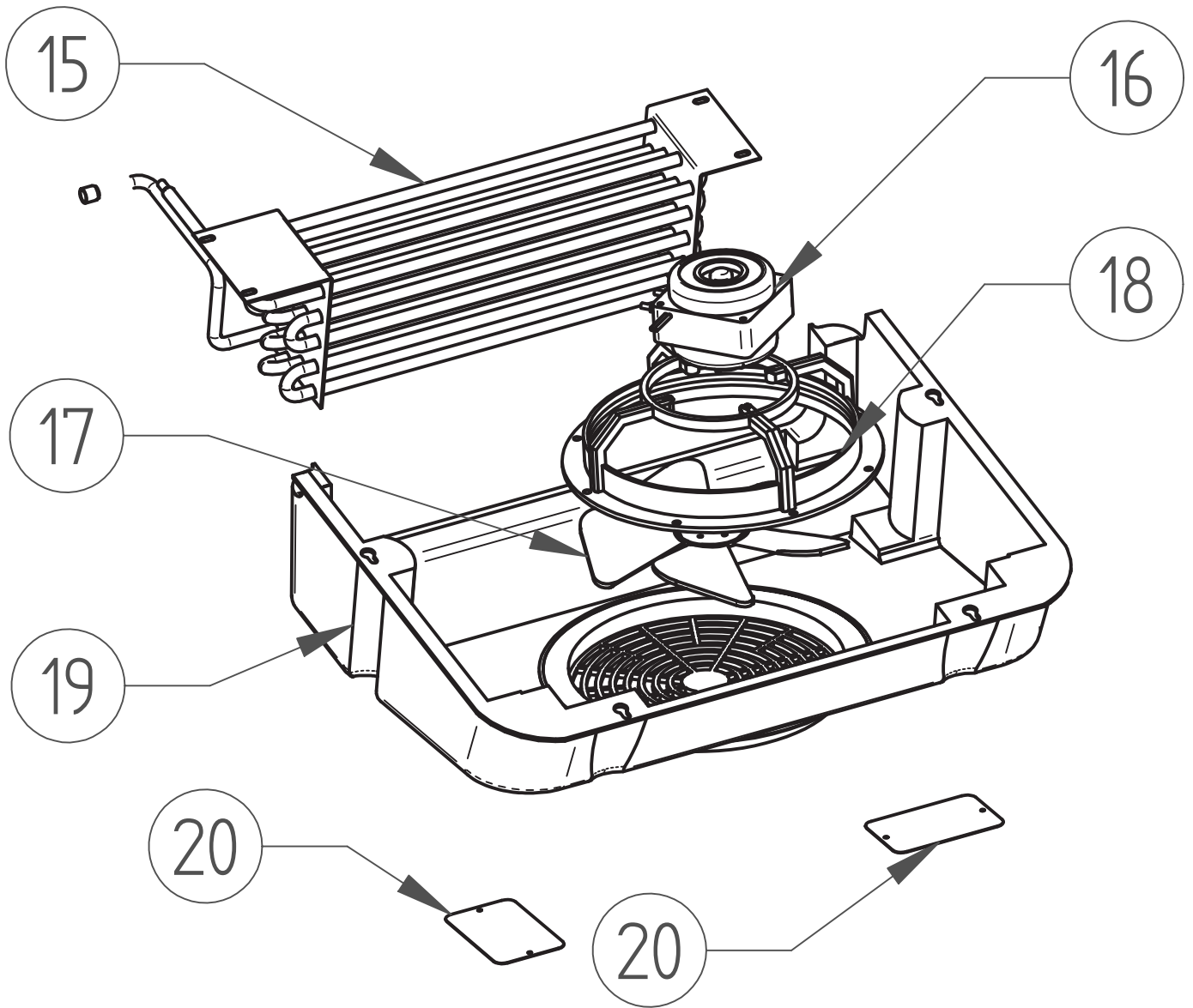



DESPIECE

PARTS BREAKDOWNS

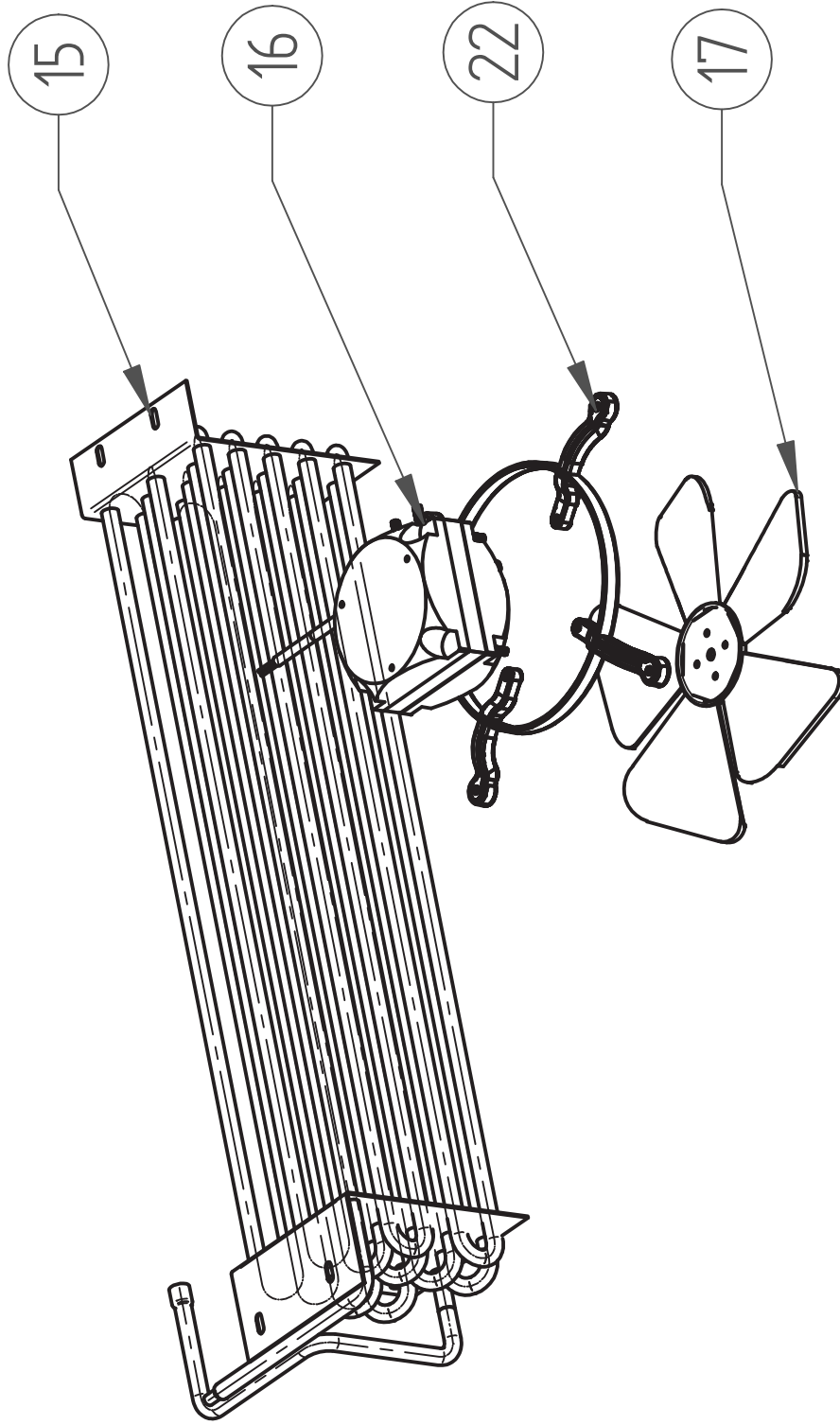

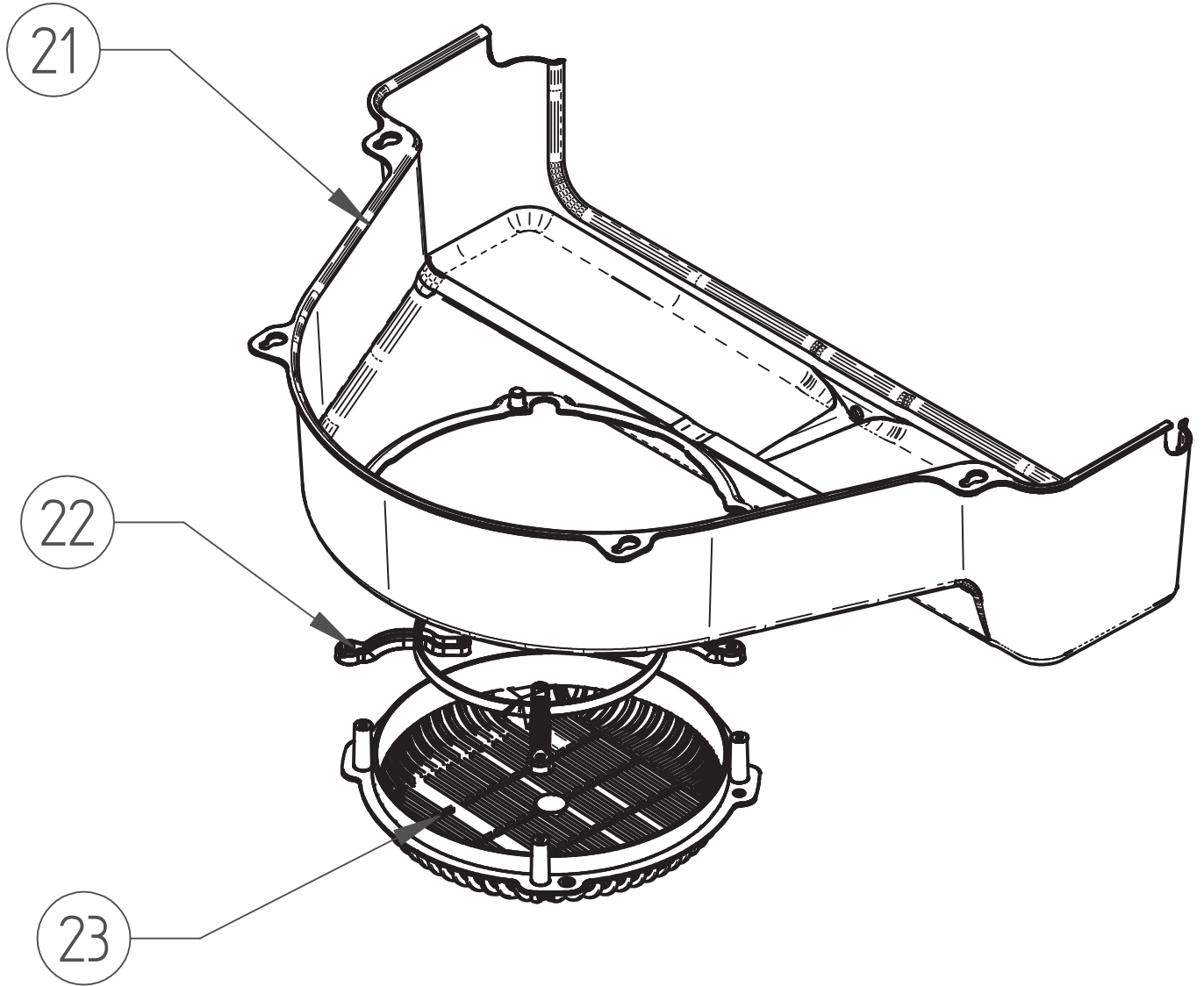

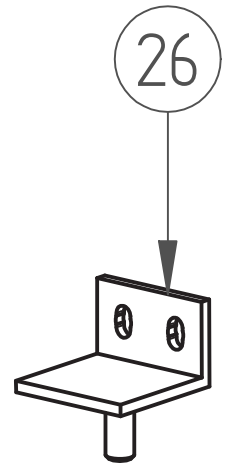
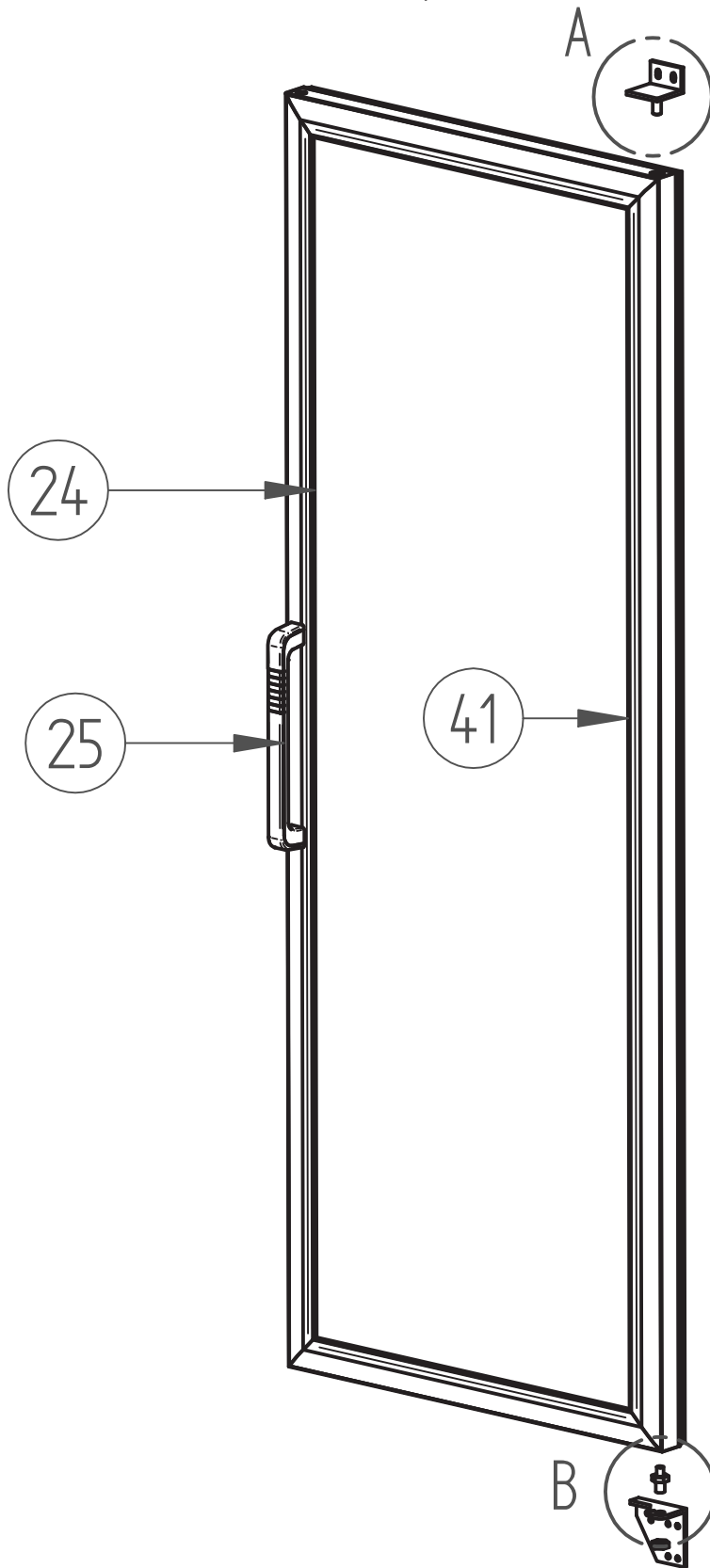

DETAIL A

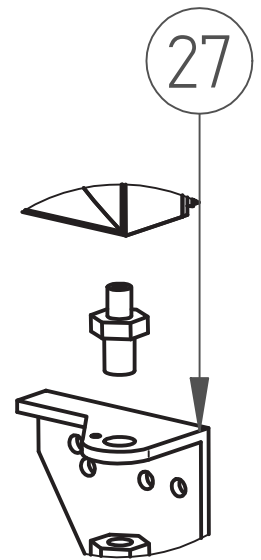

DETAIL B

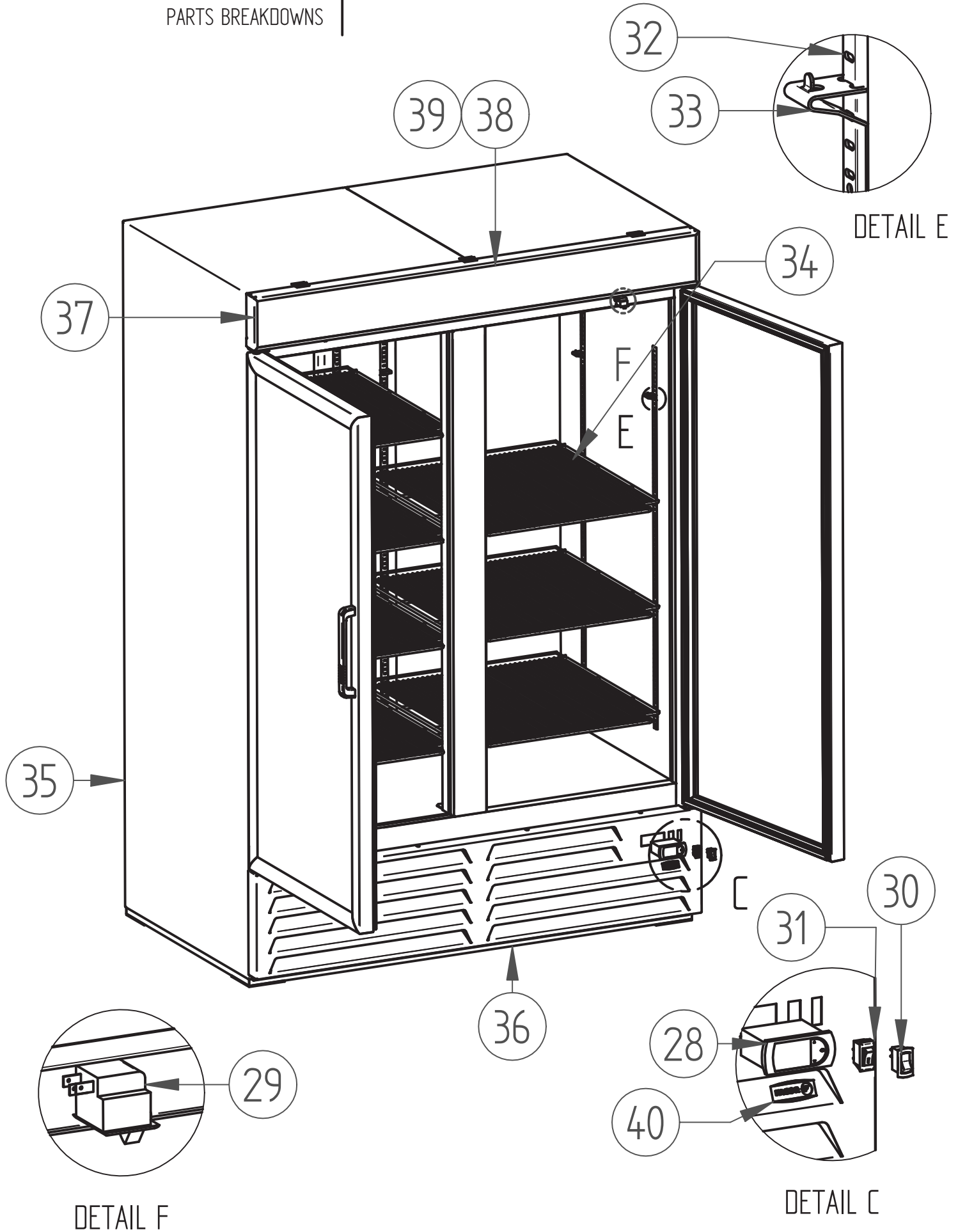

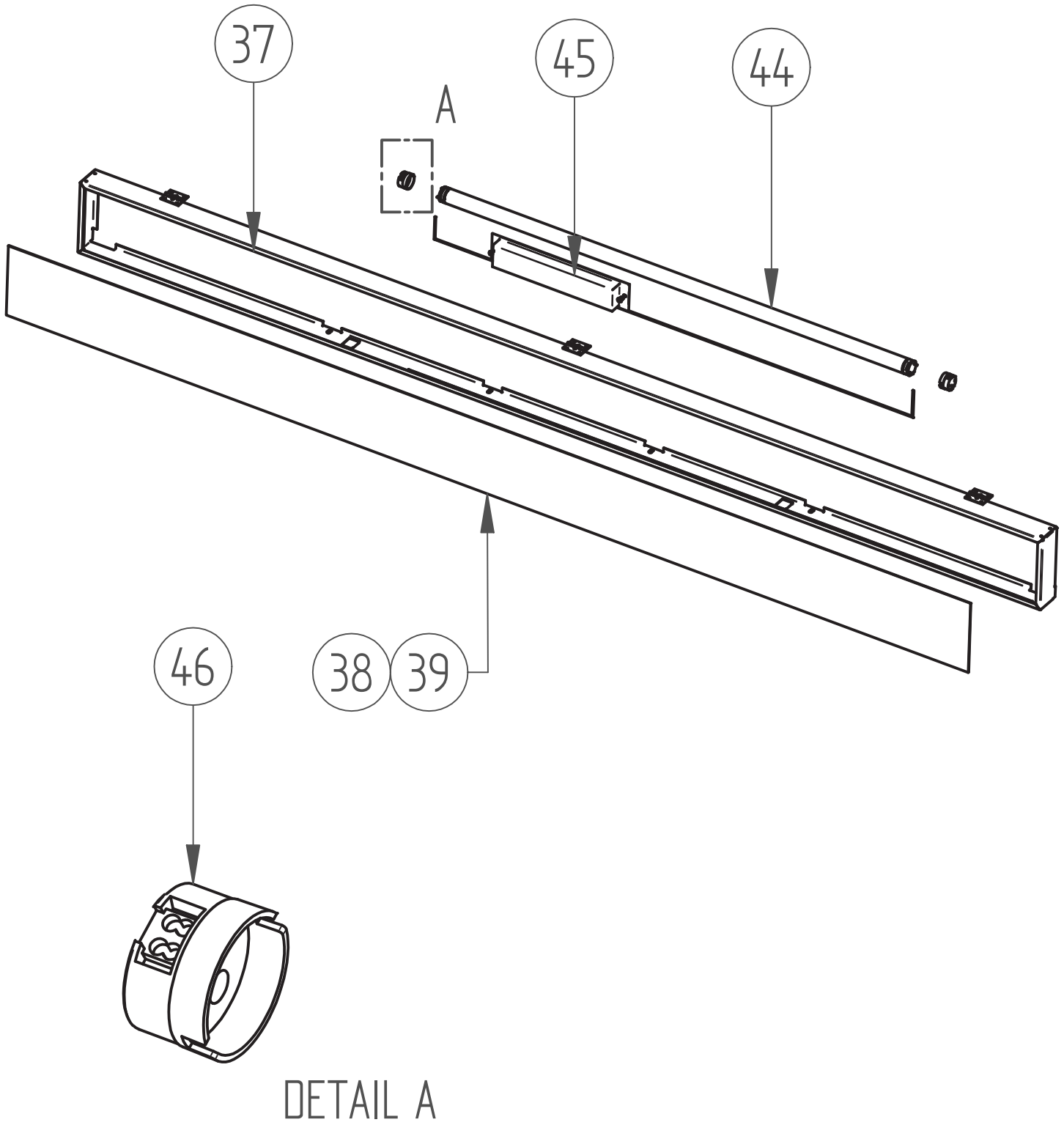

FAGOR



DESPIECE

PARTS BREAKDOWNS

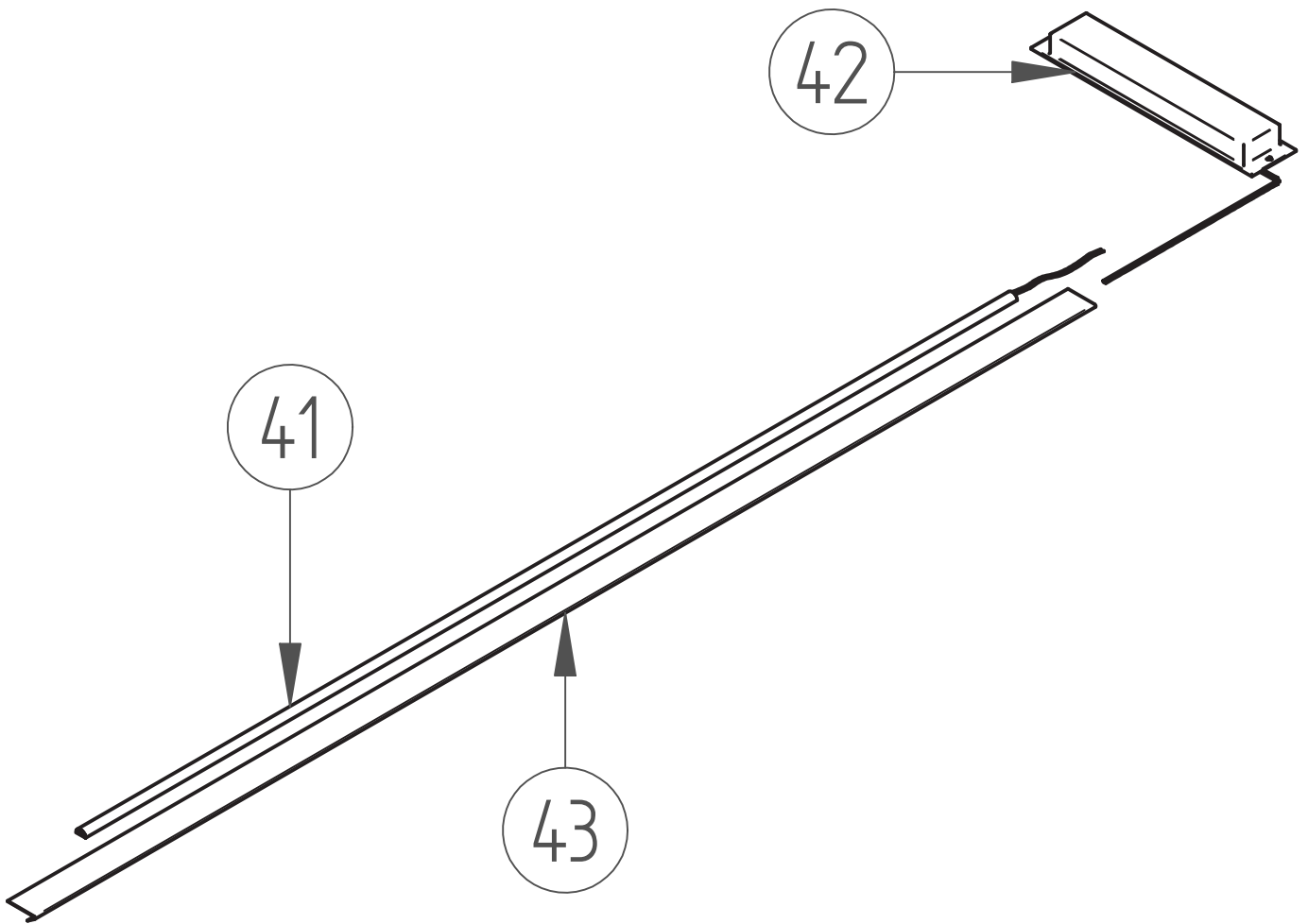

FAGOR



DESPIECE

PARTS BREAKDOWNS

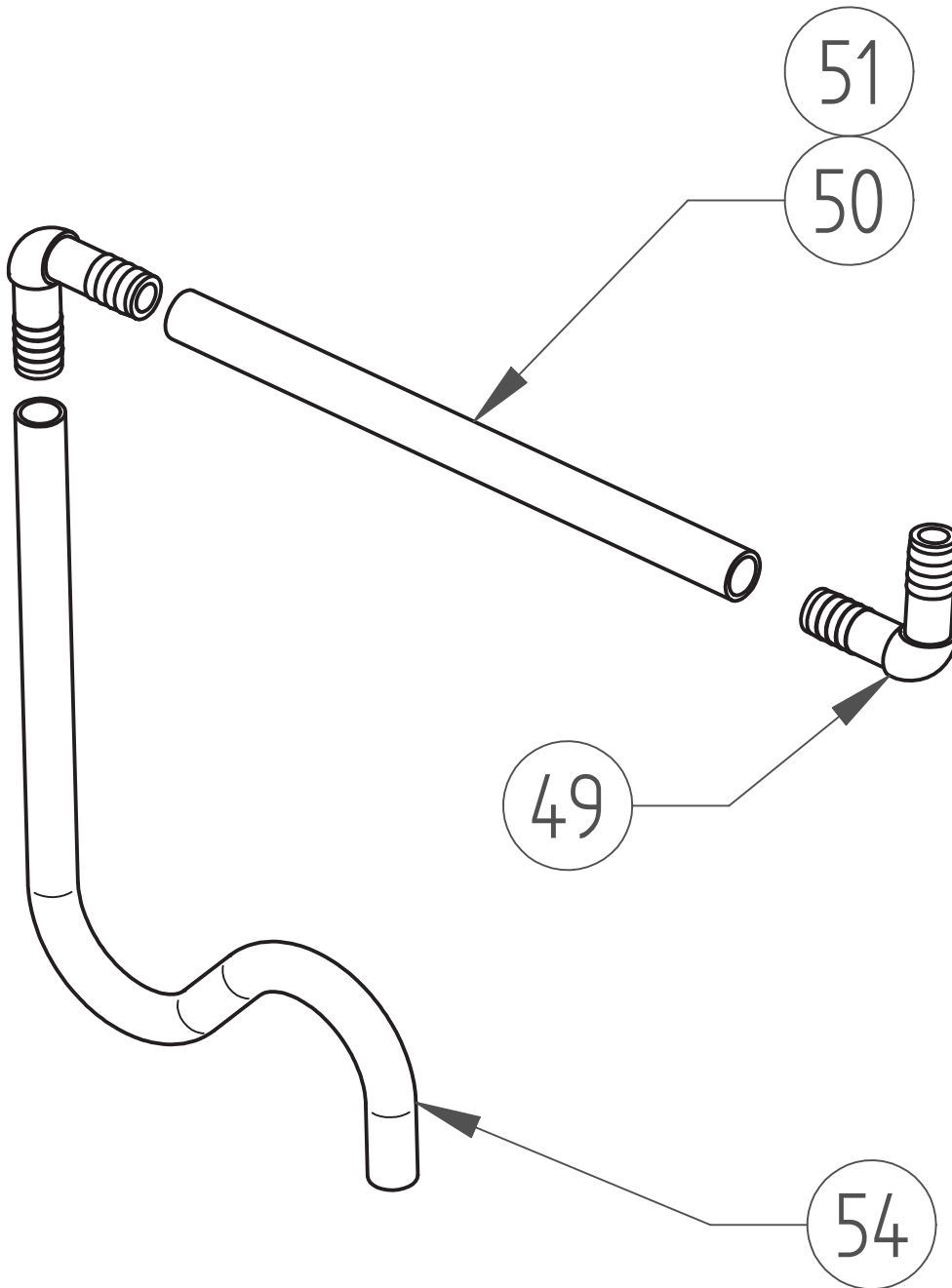

# ITEM	CODE CÓDIGO	DESCRIPTION	DESCRIPCIÓN	FM-16	FMD-23	FMD-37	FMD-49	FMD-72
Castors & Legs / Ruedas & Tacones								
1	603302M0001	LEVELER	NIVELADOR	4	4	4	4	4
Condensing Units / Unidades de Condensación								
A17301M0030		CONDENSING UNIT	UNIDAD CONDENSACION	1	1			
2	A10917M0485	DECK	BANCADA	1	1			
3	602101M0095	COMPRESSOR 115V	COMPRESOR 115V	1	1			
	602101M0101	START KIT 115V	KIT ARRANQUE 115V	1	1			
4	6029020002	CONDENSER	CONDENSADOR	1	1			
5	604701M0005	FILTER	FILTRO	1	1			
7	603301M0156	FAN SUPPORT	SOPORTE VENTILADOR	1	1			
8	602105M0003	FAN	VENTILADOR	1	1			
9	602139M0008	POWER CORD	CORDON TOMACORRIENTE	1	1			
10	6021310003	SERVICE VALVE	VALVULA OBUS	1	1			
11	6003010023	AUTOMATIC PAN TRAY	BANDEJA EVAPORACION	1	1			
12	602105M0014	FAN BLADE 9"	ASPA 9"	1	1			
13	600701M0018	HEAT EXCHANGER	INTECAMBIADOR	1	1			
14	M12145M0001	POWER CORD (SPIDER HUB)	ARAÑA CONEXIONES	1	1			
	M10702M0011	CAP TUBE	TUBO CAPILAR	1	1			
A17301M0033		CONDENSING UNIT	UNIDAD CONDENSACION			1		
2	A10917M0485	DECK	BANCADA			1		
3	602101M0096	COMPRESSOR 115V	COMPRESOR 115V			1		
	602101M0103	START KIT 115V	KIT ARRANQUE 115V			1		
4	6029020011	CONDENSER	CONDENSADOR			1		
5	604701M0005	FILTER	FILTRO			1		
7	603301M0156	FAN SUPPORT	SOPORTE VENTILADOR			1		
8	602105M0003	FAN	VENTILADOR			1		
9	602139M0008	POWER CORD	CORDON TOMACORRIENTE			1		
10	6021310003	SERVICE VALVE	VALVULA OBUS			1		
11	6003010023	AUTOMATIC PAN TRY	BANDEJA EVAPORACION			1		
12	602105M0014	FAN BLADE 9"	ASPA 9"			1		
13	600701M0012	HEAT EXCHANGER	INTECAMBIADOR			1		
14	M12145M0001	POWER CORD (SPIDER HUB)	ARAÑA CONEXIONES			1		
	M10702M0012	CAP TUBE	TUBO CAPILAR			1		
A17301M0035		CONDENSING UNIT	UNIDAD CONDENSACION				1	
2	A10917M0485	DECK	BANCADA				1	
3	602101M0096	COMPRESSOR 115V	COMPRESOR 115V				1	
	602101M0103	START KIT 115V	KIT ARRANQUE 115V				1	
4	6029020011	CONDENSER	CONDENSADOR				1	
5	604701M0005	FILTER	FILTRO				1	
7	603301M0156	FAN SUPPORT	SOPORTE VENTILADOR				1	
8	602105M0003	FAN	VENTILADOR				1	
9	602139M0008	POWER CORD	CORDON TOMACORRIENTE				1	
10	6021310003	SERVICE VALVE	VALVULA OBUS				1	
11	6003010023	AUTOMATIC PAN TRY	BANDEJA EVAPORACION				1	
12	602105M0014	FAN BLADE 9"	ASPA 9"				1	
13	600701M0012	HEAT EXCHANGER	INTECAMBIADOR				1	
14	M12145M0001	POWER CORD (SPIDER HUB)	ARAÑA CONEXIONES				1	
	M10702M0012	CAP TUBE	TUBO CAPILAR				1	

# ITEM	CODE CÓDIGO	DESCRIPTION	DESCRIPCIÓN	FM-16	FMD-23	FMD-37	FMD-49	FMD-72
A17301M0060		CONDENSING UNIT	UNIDAD CONDENSACION					1
2	A10917M0295	DECK	BANCADA					1
3	602101M0017	COMPRESSOR 115V	COMPRESOR 115V					1
	602101M0049	START KIT 115V	KIT ARRANQUE 115V					1
4	602902M0011	CONDENSER	CONDENSADOR					1
5	604701M0005	FILTER	FILTRO					1
7	603301M0156	FAN SUPPORT	SOPORTE VENTILADOR					1
8	602105M0003	FAN	VENTILADOR					1
9	602139M0008	POWER CORD	CORDON TOMACORRIENTE					1
10	6021310003	SERVICE VALVE	VALVULA OBUS					1
11	6003010023	AUTOMATIC PAN TRY	BANDEJA EVAPORACION					1
12	600305M0014	FAN BLADE 9"	ASPA 9"					1
13	600701M0012	HEAT EXCHANGER	INTECAMBIADOR					2
14	M12145M0001	POWER CORD (SPIDER HUB)	ARAÑA CONEXIONES					1
	M10702M0014	CAP TUBE	TUBO CAPILAR					1
Evaporation Units / Unidades de Evaporación								
A17101M0035		EVAPORATION UNIT	UNIDAD EVAPORACION	1	1			
15	602901M0020	EVAPORATOR COIL	EVAPORADOR	1	1			
16	602105M0003	FAN	VENTILADOR	1	1			
17	600305M0074	FAN BLADE 8"	ASPA 8 "	1	1			
18	600305M0088	FAN SUPPORT	ARO SOPORTE VENTILADOR	1	1			
19	600305M0146	EVAPORATION COVER	CUBIERTA EVAPORADOR	1	1			
20	A10917M0296	TRAY COVER PLATE	PLACA CUBIERTA EVAPORADOR	2	2			
A17101M0038		EVAPORATION UNIT	UNIDAD EVAPORACION			1	1	2
15	602901M0021	EVAPORATOR COIL	EVAPORADOR			1	1	1
16	602105M0003	FAN	VENTILADOR			1	1	1
17	600305M0074	FAN BLADE 8"	ASPA 8 "			1	1	1
M10301M0003		EVAPORATION COVER KIT	KIT CUBIERTA EVAPORADOR			1	1	2
21	600301M0088	EVAPORATION COVER	CIBIERTA EVAPORADOR			1	1	1
22	600301M0090	FAN SUPPORT	SOPORTE VENTILADOR			1	1	1
23	600301M0089	FAN GRID	REJILLA VENTILADOR			1	1	1
Doors & O thers / Puertas & Otros								
A16901M0083		DOOR KIT	ENSAMBLE DE PUERTAS	1	1			1
24	603107M0033	RIGHT DOOR	PUERTA	1	1			1
-	600717M0100	BLACK HOSE	MANGUERA NEGRA	0.15	0.15			0.15
25	6003010003	BLACK HANDLE	TIRADOR NEGRO	1	1			1
A16901M0091		DOOR KIT	ENSAMBLE DE PUERTAS					1
24	603107M0038	LEFT DOOR	PUERTA					1
-	600717M0100	BLACK HOSE	MANGUERA NEGRA					0.15
25	6003010003	BLACK HANDLE	TIRADOR NEGRO					1
A16901M0080		DOOR KIT	ENSAMBLE DE PUERTAS			1		
24	603107M0036	RIGHT DOOR	PUERTA			1		
25	6003010003	BLACK HANDLE	TIRADOR NEGRO			1		
-	600717M0100	BLACK HOSE	MANGUERA NEGRA					0.15
A16901M0090		DOOR KIT	ENSAMBLE DE PUERTAS			1		
24	603107M0040	LEFT DOOR	PUERTA			1		
25	6003010003	BLACK HANDLE	TIRADOR NEGRO			1		
-	600717M0100	BLACK HOSE	MANGUERA NEGRA					0.15

# ITEM	CODE CÓDIGO	DESCRIPTION	DESCRIPCIÓN	FM-16	FMD-23	FMD-37	FMD-49	FMD-72
	A16901M0137	DOOR KIT	ENSAMBLE DE PUERTAS					2
24	603107M0055	RIGHT DOOR	PUERTA					1
25	N/A	BLACK HANDLE	TIRADOR NEGRO					-
-	600717M0100	BLACK HOSE	MANGUERA NEGRA					0.15
	A16901M0137	RIGHT HINGE KIT	KIT BISAGRAS					2
26	A10913M0648	TOP RIGHT HINGE	BISAGRA SUPERIOR DERECHA					1
27	A10913M0649	BOTTOM RIGHT HINGE	BISAGRA INFERIOR DERECHA					1
	A16901M0138	DOOR KIT	ENSAMBLE DE PUERTAS					1
24	603107M0056	LEFT DOOR	PUERTA					1
25	6003010003	BLACK HANDLE	TIRADOR NEGRO					-
-	600717M0100	BLACK HOSE	MANGUERA NEGRA					0.15
	A16909M0008	LEFT HINGE KIT	KIT BISAGRAS					1
26	A10913M0646	TOP LEFT HINGE	BISAGRA SUPERIOR IZQUIERDA					1
27	A10913M0647	BOTTOM LEFT HINGE	BISAGRA INFERIOR IZQUIERDA					1
Controllers & Other / Controles & Otros								
28	602135M0024	CAREL CONTROLLER	CONTROL CAREL	1	1	1	1	1
29	602113M0002	DOOR SWITCH	INTERRUPTOR PUERTAS		1	2	2	3
	602113M0019	DOOR SWITCH	INTERRUPTOR PUERTAS	1				
30	6021130002	LIGHT SWITCH	INTERRUPTOR ILUMINACION	1	1	1	1	1
31	602113M0001	ROCKET SWITCH	INTERRUPTOR GENERAL	1	1	1	1	1
Shelves /Parrilas								
32	603305M0027	PILLASTER 43"	PILASTER 43"		4	8	8	12
	603305M0026	PILLASTER 37"	PILASTER 37"	4				
33	603301M0005	STAINLESS STEEL CLIP	CLIP SS ACERO INOXIDABLE	16	16	32	32	48
	602701M0035	FLAT RACK	PARRILLA	4				
34	602701M0036	FLAT RACK	PARRILLA		4			
	602701M0040	FLAT RACK	PARRILLA			8		
	602701M0041	FLAT RACK	PARRILLA				8	8
Panels /Rejillas								
	602701M0028	BACK PANEL	REJILLA POSTERIOR	1	1			3
35	602701M0044	BACK PANEL	REJILLA POSTERIOR			1		
	602701M0038	BACK PANEL	REJILLA POSTERIOR				1	
	603305M0041	BOTTOM PANEL 16" & 23"	REJILLA INFERIOR	1	1			
36	603305M0047	BOTTOM PANEL 37"	REJILLA INFERIOR			1		
	603305M0042	BOTTOM PANEL 49"	REJILLA INFERIOR				1	
	A10917M0534	BOTTOM PANEL 72"	REJILLA INFERIOR					1
Top/Canopy								
	A16113M0033	TOP PANEL 23"	CANOPY 23"	-	1			
37	A16113M0041	TOP PANEL 37"	CANOPY 37"			1		
	A16113M0046	TOP PANEL 49"	CANOPY 49"				1	
	A16113M0081	TOP PANEL 72"	CANOPY 72"					1
	602301M0110	FAGOR GRAPHIC 23"	GRAFICO FAGOR 23"		1			
38	602301M0111	FAGOR GRAPHIC 37"	GRAFICO FAGOR 37"			1		
	602301M0112	FAGOR GRAPHIC 49"	GRAFICO FAGOR 49"				1	
	602301M0113	FAGOR GRAPHIC 72"	GRAFICO FAGOR 72"					1
	600305M0157	FRONTAL PLASTIC PANEL 23"	PANEL FRONTAL PLASTICO 23"		1			
39	600305M0156	FRONTAL PLASTIC PANEL 37"	PANEL FRONTAL PLASTICO 37"			1		
	600305M0152	FRONTAL PLASTIC PANEL 49"	PANEL FRONTAL PLASTICO 49"				1	
	600305M0167	FRONTAL PLASTIC PANEL 72"	PANEL FRONTAL PLASTICO 72"					1

# ITEM	CODE CÓDIGO	DESCRIPTION	DESCRIPCIÓN	FM-16	FMD-23	FMD-37	FMD-49	FMD-72
Others /Others								
40	603317M0001	FAGOR PLATE (LITTLE)	PLACA FAGOR PEQUEÑA	1	1	1	1	1
41	602129M0046	LED LAMP 1.4M	LAMPARA LED		1		2	
	602129M0045	LED LAMP 1.2M	LAMPARA LED	1		2		3
42	602129M0023	DRIVER	BALASTRO	1	1	1	1	1
43	A10905M0321	LED SUPPORT	SOPORTE LAMPARA LED	1	1	1	1	1
	602129M0040	FLUERESCENT LAMP	LAMPARA FLUORESCENTE		1			
44	602129M0018	FLUERESCENT LAMP	LAMPARA FLUORESCENTE			1		2
	602129M0005	FLUERESCENT LAMP	LAMPARA FLUORESCENTE				1	
45	602129M0010	BALLASTER	BALASTRO		1	1	1	1
46	602129M0041	SOCKET LAMP	SOCKET LAMPARA FLUORESCENTE		2	2	2	4
47	602101M0088	CONTACTOR 30A	CONTACTOR 30A			1	1	1
Drain/Desague								
48	600717M0086	RIGID DRAIN HOSE	MAGUERA DESAGUE RECTA	1	1	1	1	2
49	600717M0099	PLASTIC DUGIN FITTING	CODO 90° ESPIGA DOBLE	2	2	2	2	2
50	600717M0088	FLEX DRAIN HOSE 5/8"	MAGUERA DESAGUE FLEXIBLE	0.4	0.4	0.4	0.4	
51	600717M0087	FLEX DRAIN HOSE 1/2"	MAGUERA DESAGUE FLEXIBLE					0.3
52	600301M0035	PLASTIC COUPLE FITTING	COPLER DESAGUE	1	1	1	1	2
53	600717M0096	PLASTIC FITTING " Y "	COPLER DESAGUE "Y"					1
54	600717M0070	DRAIN HOSE	MAGUERA DESAGUE CURVA	1	1	1	1	1

FAGOR



CUSTOMER SERVICE

Fagor Commercial, Inc.
13105NW 47thAve
Miami, FL. 33054
Tel:(305) 7790170
Fax:(305)7790173
1-866-463-2467
www.Fagorcommercial.com

Circuito Exportación N° 201
Parque Industrial Tres Naciones
San Luís Potosí, S.L.P. México
C.P. 78395
Planta S.L.P.: + 52 (444) 137 0500
México D.F.: + 52 (55) 5082 5825

SERVICIO TECNICO