



The Signature of Quality™

INSTALLATION & OPERATIONS INSTRUCTIONS
REFRIGERATED LPRSS-2 MODELS



KEEP THIS MANUAL FOR FUTURE REFERENCE

Engineering and technical data are subject to change without notice.

FEDERAL INDUSTRIES
Toll Free 1(800) 356-4206

215 FEDERAL AVE
WI Phone (608) 424-3331

Belleville, WI 53508
Fax: (608) 424-3234

CONTENTS

INTRODUCTION	3
WARNING LABELS & SAFETY INSTRUCTIONS	4
PRE-INSTALLATION PROCEDURES	5
<u>Inspection For Shipping Damage</u>	5
GENERAL ELECTRICAL & GROUNDING	5
<u>Cord Connected</u>	5
<u>Permanent Connected (Option)</u>	5
INSTALLATION INSTRUCTIONS	6-8
<u>Locating The Display Case</u>	6
<u>Removing Case From Shipping Skid</u>	6
<u>Cleaning</u>	6
<u>Center Panel Joining (Option)</u>	7
<u>Refrigeration System</u>	8
Self Contained Models	8
Remote Models.....	8
<u>Evaporator Condensate Drain Tube</u>	8
<u>Condensate Pump</u>	9
SHELVING INSTALLATION & REMOVAL	10-12
<u>Metal Shelves</u>	10
<u>Glass Shelves</u>	11
<u>Optional Shelf Lights (Option)</u>	12
PLASTIC END REMOVAL & INSTALLATION	13
REAR DOORS (OPTION)	12
NIGHT CURTAIN (OPTION)	14
SECURITY NIGHT COVER (OPTION)	15
OPERATING INSTRUCTIONS	16
<u>User Controls</u>	16
<u>Temperature Control Function</u>	17
<u>Initial Start Up</u>	17
<u>Placing Product In Case</u>	18
MAINTENANCE	19
<u>Light Replacement</u>	19
PERIODIC MAINTENANCE	19
<u>Cleaning Condenser Coil</u>	19
CLEANING INSTRUCTIONS	20-21
<u>Daily Cleaning</u>	20
<u>Weekly Cleaning</u>	20-21
SALE & DISPOSAL	22
<u>Owner Responsibility</u>	22
SERVICE INFORMATION	22
<u>Pre-Service Checklist</u>	23
<u>Special Service Situations</u>	23
<u>Refrigeration & Electrical Data</u>	24
<u>Electronic Control Operation</u>	24
<u>Control Factory Settings</u>	25
<u>Control Display</u>	25
<u>Refrigeration Operation</u>	26
Self Contained Models	26
Remote Models.....	26-27
WIRING DIAGRAMS	28
<u>Self Contained</u>	28
<u>Remote</u>	28
REPLACEMENT PARTS	29-30

INTRODUCTION

Thank you for purchasing a Federal Industries display case. This manual contains important instructions for installing and servicing the LPRSS Refrigerated Self-Service Merchandisers. A repair parts list and wiring diagram are also included in the manual. Read all of these documents carefully before installing or servicing your case.



NOTICE

Read this manual before installing your case. Keep this manual and refer to it before doing any service on the equipment. Failure to do so could result in personal injury or damage to the case.



NOTICE

Installation and service of the electrical components in the case must be performed by a licensed electrician.

The portions of this manual covering components contain technical instructions intended only for persons qualified to perform electrical work.



DANGER

Improper or faulty hookup of electrical components in the case can result in severe injury or death.

All electrical wiring hookups must be done in accordance with all applicable local, regional, or national standards.

SERIAL NUMBER

Record the model and serial numbers of the case for easy reference. Always refer to both model and serial numbers in your correspondence regarding the case.

Case Model _____ Serial Number _____
Condensing Unit Model _____ Serial Number _____

This manual cannot cover every installation, use, or service situation. If you need additional information, call or write us:

WARRANTY/TECHNICAL SERVICE DEPARTMENT

Federal Industries

P.O. Box 290

Belleville, WI 53508

Toll Free (800) 356-4206 / WI Phone (608) 424-3331

WARNING LABELS & SAFETY INSTRUCTIONS



This is the safety-alert symbol. When you see this symbol on your case or in the manual, be alert to the potential for personal injury or damage to your equipment.

Be sure you understand all safety messages and always follow recommended precautions and safe operating procedures.



NOTICE TO EMPLOYERS

You must make sure that everyone who installs, uses, or services your case is thoroughly familiar with all safety information and procedures.

Important safety information is presented in this section and throughout the manual. The following signal words are used in the warning and safety messages:

DANGER: Severe injury or death will occur if you ignore the message.

WARNING: Severe injury or death can occur if you ignore the message.

CAUTION: Minor injury or damage to your case can occur if you ignore the message.

NOTICE: This is important installation, operation, or service information. If you ignore the message, you may damage your case.

The warning and safety labels shown throughout this manual are placed on your Federal Industries case at the factory. Follow all warning label instructions. If any warning or safety labels become lost or damaged, call our customer service department at 1(800) 356-4206 for replacements.

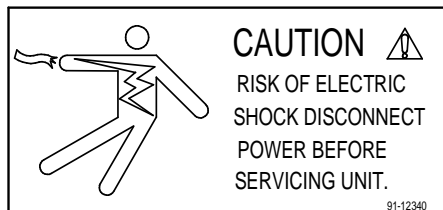

This label is located on the back of the display case.

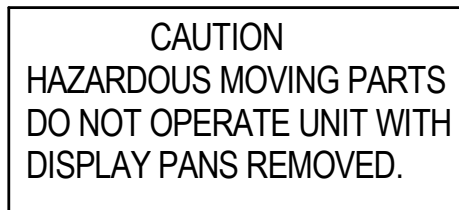

This label is located below the display pan.

PRE-INSTALLATION PROCEDURES

Inspection for Shipping Damage

You are responsible for filing all freight claims with the delivering truck line. Inspect all cartons and crates for damage as soon as they arrive. If damage is noted to shipping crates, cartons, or if a shortage is found, note this on the bill of lading (all copies) prior to signing.

If damage is discovered when the case is uncrated, immediately call the delivering truck line and follow up the call with a written report indicating concealed damage to your shipment. Ask for an immediate inspection of your concealed damage item. Crating material must be retained to show the inspector from the truck line.

GENERAL ELECTRICAL & GROUNDING



DANGER: Improper or faulty hookup of electrical components in the display case can result in severe injury or death.

Cord Connected

-All standard models are supplied with a power cord that is properly sized to the amperage requirements of the case. See the electrical data plate located on the rear left interior of the case for the proper circuit size for each case.

- The cord is factory installed protruding from the bottom rear corner of the case.
- A separate circuit for each display case is required to prevent other appliances on the same circuit from overloading the circuit and causing malfunction.

Permanent Connected (OPTION)

- Only a licensed electrician must perform all case electrical connections.
- All electrical wiring hookups must be done in accordance with all applicable local, regional, or national electrical standards.
- A separate circuit for each display case is required to prevent other appliances on the same circuit from overloading the circuit and causing malfunction.
- The electrical service must be grounded upon installation.
- See the electrical data plate located at the rear of the case for proper circuit size and wire ampacity.
- The electrical connection box is accessible from the rear of the case with rear grill removed.

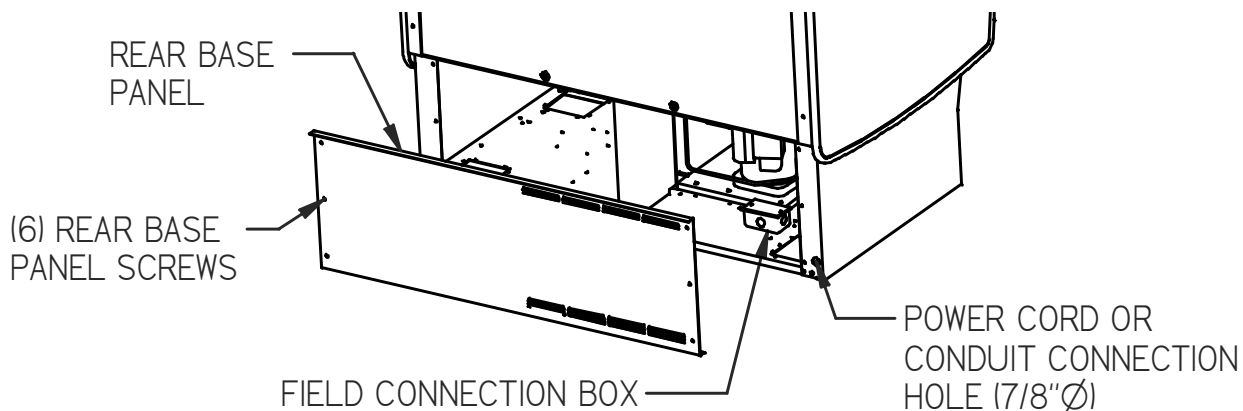

INSTALLATION INSTRUCTIONS

Locating Display Case

The case should be located where it is not subjected to the direct rays of the sun, heating ducts, grills, radiator, or ceiling fans, nor should it be located near open doors or main door entrances. Also, avoid locations where there are excessive air movement or air disturbances.

The case requires a minimum of 6” clearance at the rear of the unit for air discharge. Do not locate case with back tight against the wall. The louvers located on front of base must remain clear for air intake. If rear clearance or front clearance is not possible see a Federal representative for air intake and discharge kit options.

No clearance is needed on sides of the unit.

Removing Case From Shipping Skid and General Installation



CAUTION: Do not push or pull against the top panel, plastic end, end glass, or door frames when removing the case from the skid or moving the case. Case damage or glass breakage could result.

1. Remove crate top and sides and note missing or damaged items as explained in the pre-installation procedures outlined above.
2. Move the case as near as possible to the final location and before removing it from the shipping skid.
3. Remove the (4) brackets that secure the case to the shipping skid.
4. Prepare cabinet according to instructions in this section that pertain to your model.
5. Lift the case off of skid and into required position. Only lift the case from under the rear lip and front bottom trim channel above the base. Note: Do not push or pull on front bottom trim channel or lift using the plastic end panel.
6. The case must be level for proper drainage of defrost condensate to the condensate evaporator. Using the wrench provided level and square the case as needed by adjusting the leg leveler in each corner of base. The 6' cases also have a set of leg levelers in the center. These must be adjusted so the base is flat.
7. The leveled case must be sealed to the floor using a NSF Listed Sealant.

Cleaning

For initial setup, clean the case as outlined in the “Weekly Cleaning” section of this manual.

Center Panel Joining (Option)

If your cases were ordered with the Center Panel Joining Option you will need to perform the following installation procedures.

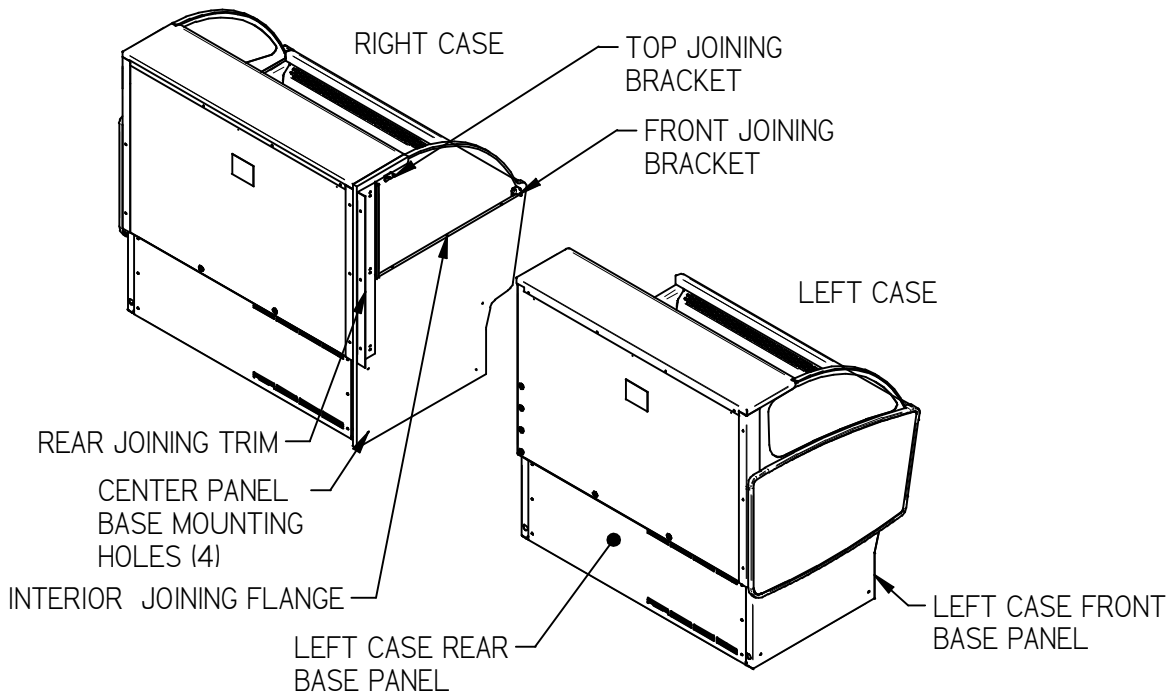

1. Place the right case into desired location and level case by adjusting leg levelers with provided wrench.
2. Remove the front base panel (4) screws and rear base panels (6) screws from the left case. Push the left case end tightly against the right case end. The rear joining trim on the right case must be behind the back panel of the left case and the front joining bracket on the right case must be inside the front aluminum trim channel of the left case.
3. Adjust the leg levelers on the left case so it is level and exactly aligned with the right case. The (4) base mounting hole in the right case panel must align with the (4) mounting holes located in base compartment of left case.
4. Push the cases together as tightly as possible and the gap between the cases must be tight and even. If the gap is larger at the top or the bottom adjust leg levelers accordingly. **HOLD CASES TOGETHER AS TIGHT AS POSSIBLE WHILE ATTACHING ALL JOINING BRACKETS AND DO NOT OVER TIGHTEN SCREWS OR SCREWS WILL STRIP OUT.**
5. Attach the bottom of the left case to the right case center panel base mounting holes through the holes located inside of the left case base. Use the (4) large 10-12x1/2 screws provided.
6. Attach the rear top of left case through the holes in the rear joining bracket using the (3) black #10-12x1/2 self drilling screws provided.
7. Attach the front of left case through the holes in the front joining bracket using the (2) smaller #8-12x1/2 self drilling screws provided.
8. Attach the top of left case through the holes in the top joining bracket using the (2) smaller #8-12x1/2 self drilling screws provided.
9. Attach the interior of left case through the holes in the interior joining flange using the (3) smaller #8-12x1/2 self drilling screws provided.
10. If any there are any gaps along the joining seam fill them with NSF black silicone.
11. Reinstall front and rear grills.

Refrigeration System:

Self Contained Models

The self-contained models are shipped from the factory with a completely operational 404A refrigeration system and require no modifications or adjustments upon installation. Case must be installed as per the installation section of this manual to provide proper condensing air cooling.

Remote Models

The remote models are designed to use 404A refrigerant and shipped from the factory with the evaporator coil, expansion valve, sight glass, service valves and refrigerant solenoid valve. Installation must be performed by a licensed Refrigeration Technician. See the Service section of this manual for installation requirements.

Evaporater Condensate Drain Tube:



WARNING TO INSTALLER

Evaporator Condensate Drain Tube may become dislodged during shipping. Installer must check Evaporator Condensate Drain Tube upon installation to be sure drain tube is properly seated and installed correctly.

Evaporator Drain Tube must be attached to tube protruding from bottom of Evaporator Tub and must either be inside the Condensate Pan area or inside of hole of Condensate Pump.

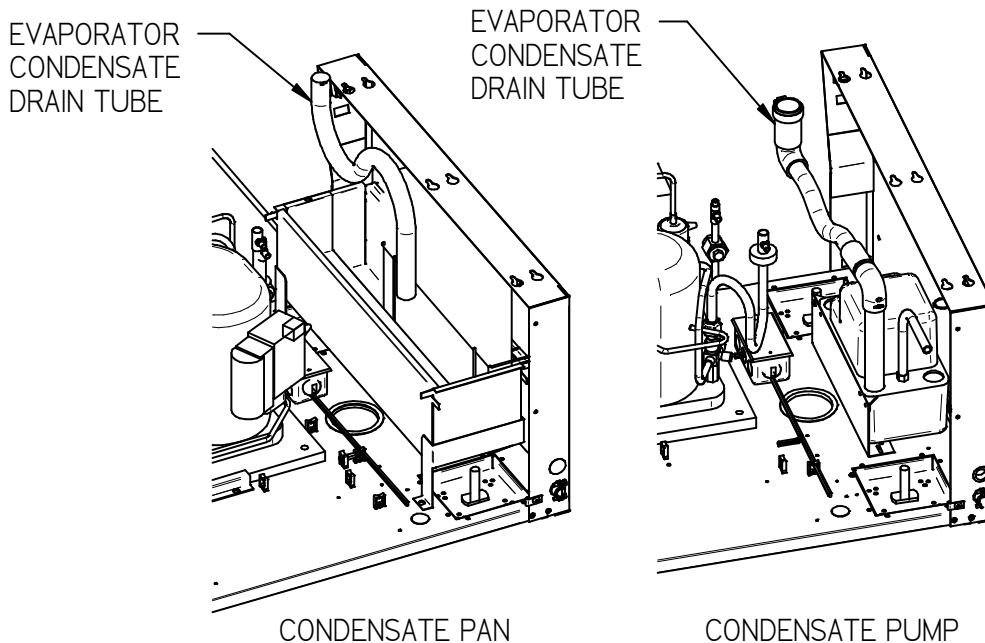

Condensate Pump:

A condensate pump is Standard on some models and Optional on all models. Installer must check unit to see if a condensate pump has been provided with case.



WARNING TO INSTALLER

Installer must determine if case was provided with condensate pump. Failure to hook up pump hose to drain will cause water on floor and cause a slip hazard.

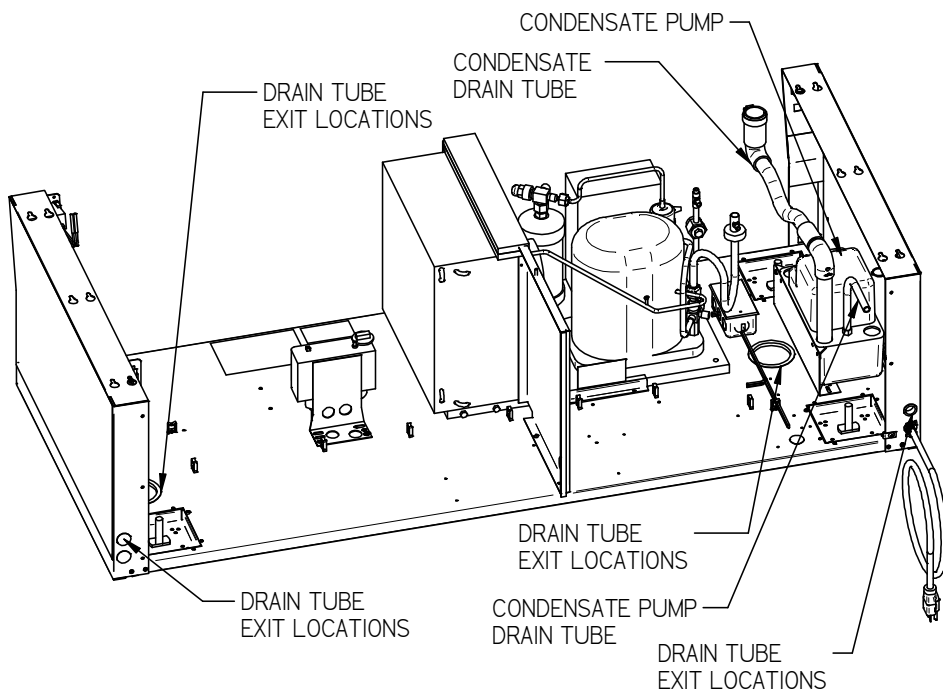

Instead of using heat energy to remove condensate run off from evaporator coil a condensate pump pumps the water to a nearby drain.

-The Condensate Pump is provided with 50' of clear 1/2 OD x 3/8 ID tubing that must be run out of base area to a drain.

-There are several Drain Tube exit locations provided in base as noted in drawing above. Plugs or caps will need to be removed in desired exit location.

-Hose can be run entire 50' in any direction as required, but no higher than 20' from pump base. A check valve is provided in pump to prevent water from flowing back into reservoir. For best efficiency extend hose level below or level of pump base to create a siphoning effect. Never run hose to or through an area below freezing or freezing water will block tube.

SHELVING INSTALLATION & REMOVAL

Metal Shelves Installation

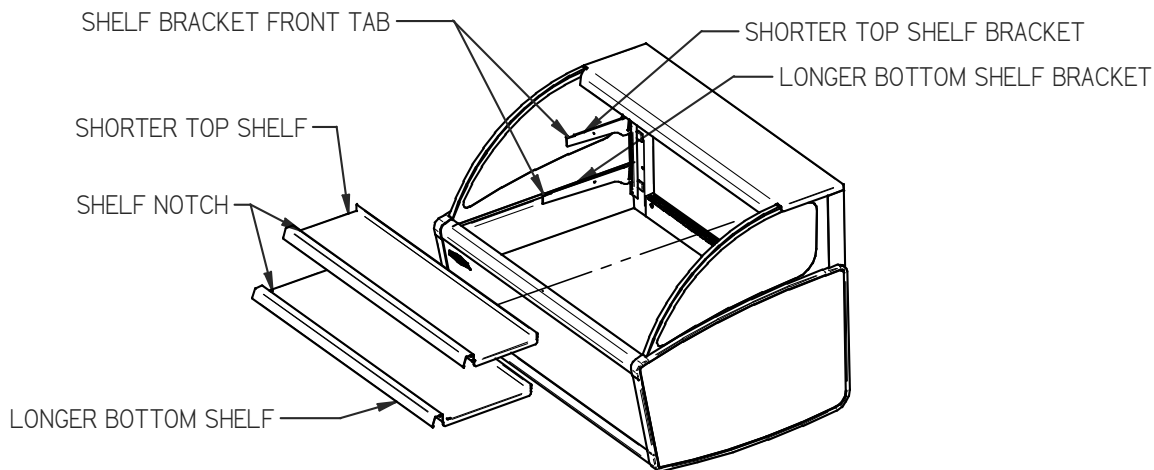

1. Follow the instruction in the illustration below and insert (1) of the (2) longer bottom shelf brackets in the desired shelf standard slot on one side of the case. Place the additional longer bottom shelf bracket in the same shelf standard slot on the opposite end of case. If the case was supplied with shelf light option, The bracket with a clear plastic cord retainer clip must be on the side with the shelf light. Repeat for shorter top shelf brackets.

Note: The best starting point for shelf bracket position is to leave (1) shelf standard slot open above the top shorter bracket and (1) shelf standard slot open below the longer bottom shelf bracket.

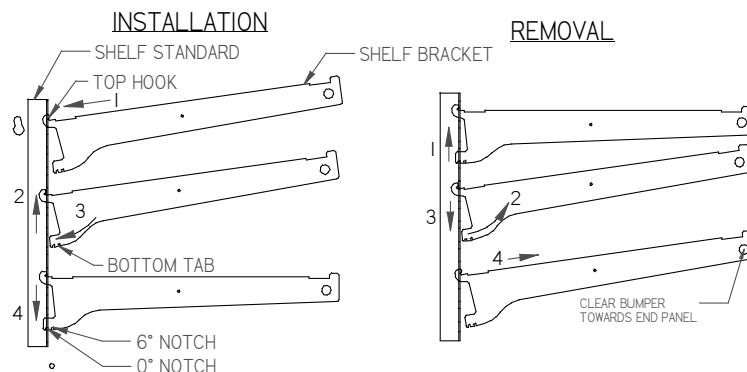

1. Place shelf bracket top hook into desired shelf standard slot.
 2. Lift shelf bracket top hook to allow shelf bracket bottom tab to clear shelf standard slot.
 3. Swing shelf bracket bottom tab into shelf standard slot.
 4. Place the desired shelf bracket notch of 0, 6, or 12 degrees onto bottom of shelf standard slot.
1. Lift shelf bracket up to allow shelf bracket notch to clear the bottom of shelf standard slot.
 2. Swing shelf bracket bottom tab out of shelf standard slot.
 3. Drop shelf bracket down to allow shelf bracket top hook to clear top of shelf standard slot.
 4. remove shelf bracket top from shelf standard slot.

2. Place the longer bottom shelf on top of the longer bottom shelf brackets with the flanges on each end of the shelf overhanging the outside of the bracket. Place the front tab of the shelf bracket into the notch located on the front of the shelf.
3. Place the shorter top shelf on top of the shorter top shelf brackets with the flanges on each end of the shelf overhanging the outside of the bracket. Place the front tab of the shelf bracket into the notch located on the front of the shelf.
4. If shelves include optional lights plug the cords into plug receptacle in rear of case.

Glass Shelves Installation

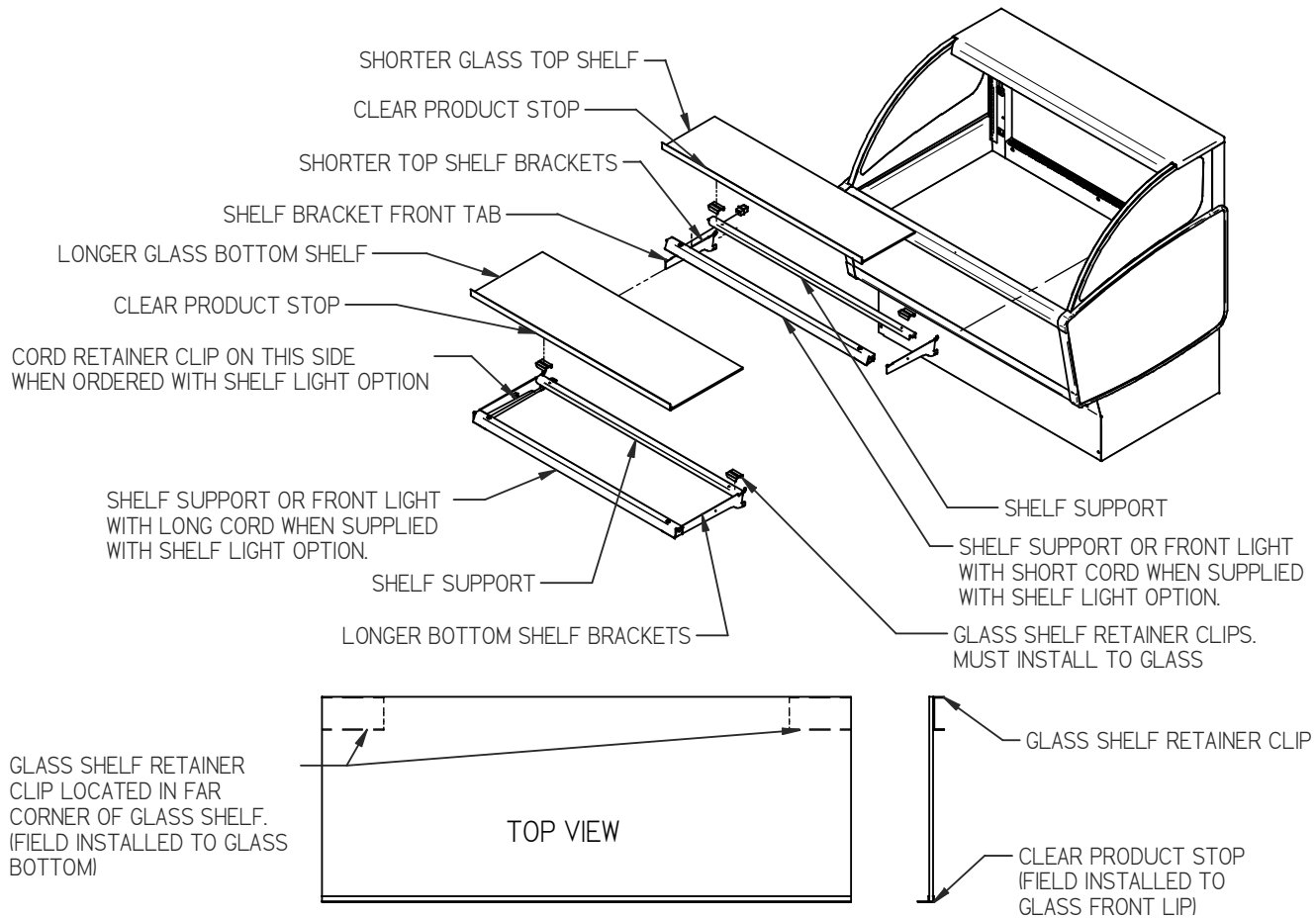

1. For first time installation attach (2) glass shelf retainer to each glass shelf. Remove backing from tape located on flat side of glass shelf retainer. Position the glass shelf retainer in the (2) far corners of glass as shown in detail drawing above. Repeat for each glass shelf.
NOTE: Clean area of glass where glass shelf holder is to be located with isopropyl alcohol and let air dry before installing shelf glass holder.
2. For first time installation attach (1) clear glass product stop to each glass shelf as shown in detail above. Align the clear product stop edge with the edge of the glass and push the "U" portion of the glass product stop on to glass lip across the entire front of glass. Repeat for each glass shelf.
3. Install the shelf brackets into shelf standard as described in Step (1) of "Metal Shelves Installation" of this manual.
4. Place front of glass shelf onto front shelf support. (on to front shelf light for models with shelf lights.)
5. Set the rear of the glass shelf onto the rear shelf support so that the glass shelf retainers straddles the rear shelf support.
6. Repeat steps 2 & 3 for each tier.

Optional Shelf Lights Installation

1. Install shelves as described in the Metal Shelves Installation and Glass Shelves Installation sections in this manual. Note: On models with glass shelves with lights a shelf support will be placed on the back of the shelf bracket and a shelf light housing will be placed on the front of the shelf bracket.
2. Push shelf light cords into clear plastic clip located on inside of shelf brackets.
3. Remove the cap from the appropriate female light sockets.
IMPORTANT: Grip each side of cap firmly and wiggle and pull cap straight out of socket. Do not roll cap during removal. Incorrect removal of cap may cause damage to electrical connection.
4. If the socket is not being used for a shelf light, the cap must be plugged into socket for entire light system to operate.
5. Plug in each shelf light by aligning the male pins on the appropriate shelf light cord plugs with the female light sockets and push together. **IMPORTANT:** Do not roll plug during insertion.

Shelves and shelf light quantity

It is not required that all shelves and shelf lights supplied with each case are used. The quantity of shelves and shelf lights can be tailored to your specific needs. If the supplied quantity of shelves and shelf lights are not required, cap unused female socket located in interior of the case mullion with caps supplied. Failure to do so will prevent entire lighting system from operating.

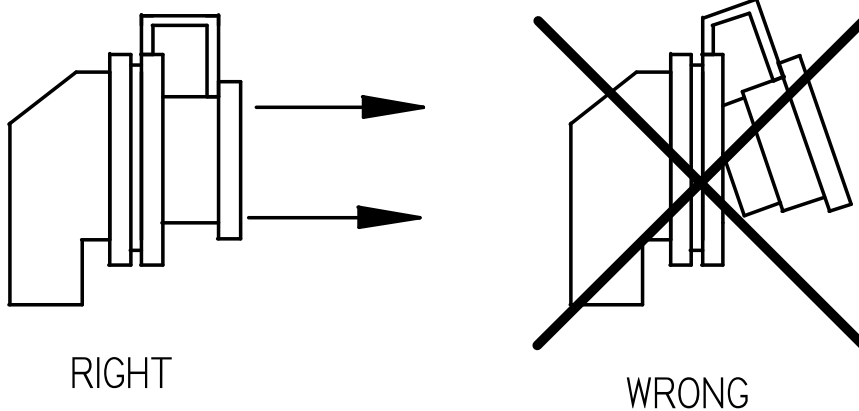

IMPORTANT: Grip each side of cap firmly and wiggle and pull cap straight out of socket. Do not roll cap during removal. Incorrect removal of cap may cause damage to electrical connection.

PLASTIC END REMOVAL & INSTALLATION

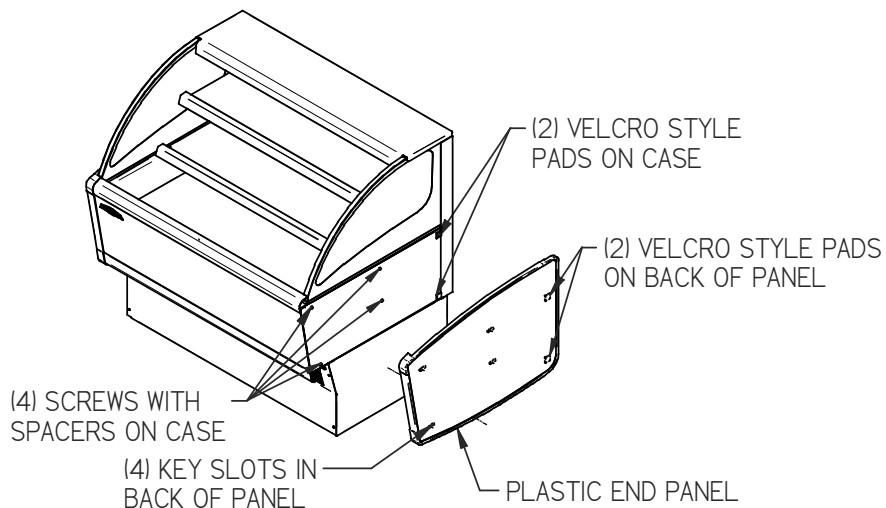

Right and Left plastic end panels are ordinarily shipped installed from the factory but can be easily removed for cleaning. Removing end panels make it easier to grab on to case when moving or installing case and can easily be reinstalled.

REMOVAL:

1. Lift the back side of the panel out to disengage (2) Velcro style pads
2. Slide the panel forward to disengage the (4) Key slots in panel from (4) screws in case.

INSTALLATION:

1. Hold panel tightly against the side of the case with the front lip of panel tight against front of case.
2. Slide panel forward about $\frac{1}{2}$ until screws fall into key slots. Slide the panel towards the back of case making sure all (4) key slots engage.
3. Push in on end panel in location of the (2) Velcro style pads to lock panel in place.

REAR DOORS (OPTION)

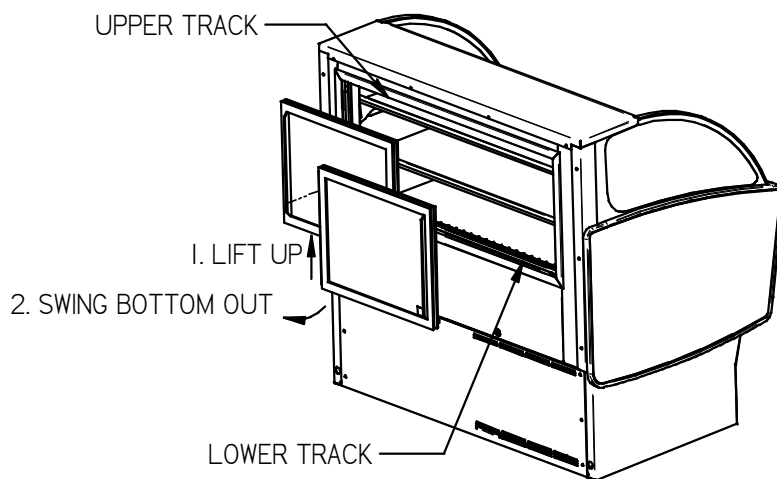

1. Start with the outer door and lift the door upward until the bottom edge of door clears the lower track and then swing the bottom of the door outward and down out of upper track.
2. After the outer door is removed repeat the procedure for the inner door.
3. Reverse this procedure for door reinstallation. The doors are not interchangeable.

NIGHT CURTAIN OPERATION

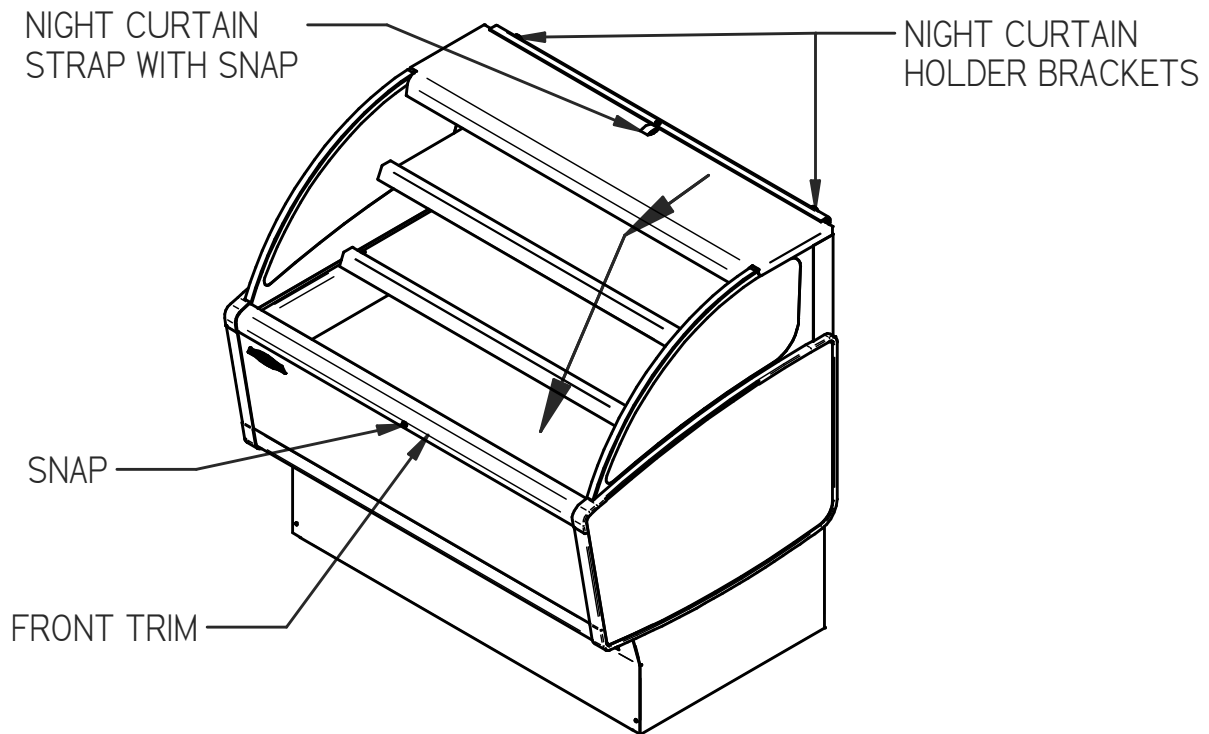

OPENING:

1. Grab night curtain strap and lift the rolled night curtain out of the night curtain holder brackets. Pull the night curtain across the top of case and down the front.
2. Attach the snap located under the night curtain strap on to the snap located on the front trim.

CLOSING:

1. Grab the night curtain strap and detach the snap from the snap located in the front top trim.
2. While holding the night curtain strap allow the night curtain to roll up and place the rolled night curtain carefully into the night curtain holder brackets.

Note: The 5' and 6' models have (2) night curtains.

SECURITY NIGHT COVER (OPTION)

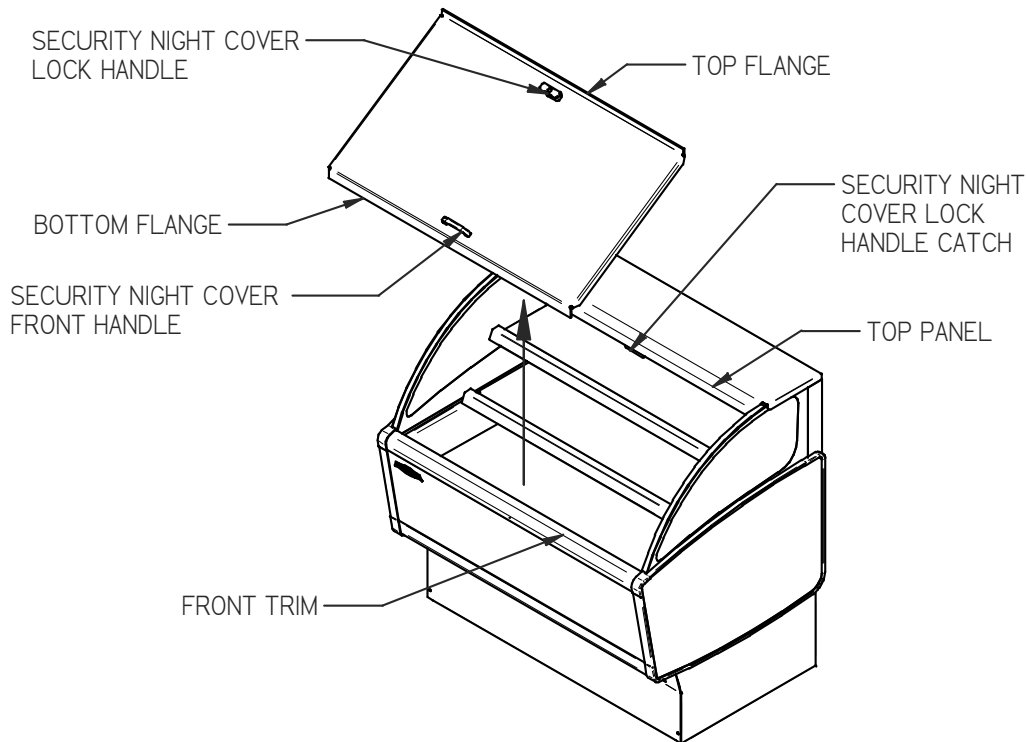

REMOVAL:

1. Unlock the lock handle and turn handle to disengage from lock handle catch.
2. Grab the lock handle and the front handle and lift the cover straight up out of the case opening.

INSTALLATION:

1. Turn the lock handle so the latch is horizontal to the top of the case.
2. Holding the lock handle and the front handle place the bottom flange of the security night cover inside of case opening. The bottom flange of the security night cover must be tight against the flat inner side of the front trim.
3. Set the top flange of the security cover down against the top panel.
4. Turn the lock handle so it engages the lock handle catch and use key to lock it in place.

Note: The 6' models have (2) security covers.

IMPORTANT: Cleaning the Acrylic plastic security night cover require special care to prevent hazing of material. Lightly dust (not wipe) the surface with clean soft cloth. Then the surface can be wiped carefully with a soft, wet cloth or chamois. The cloth or chamois must be kept free of grit by frequently rinsing in clean water. Grease and oil can be removed with kerosene. Do not use window cleaners or kitchen scouring compounds. **DO NOT** use solvents such as Acetone, Benzene, Carbon Tetrachloride, and Lacquer Thinners. A spray wax such as Pledge or Maguire's polish can be applied and wiped with a clean soft cloth. The wax tends to fill in and hide small scratches

OPERATING INSTRUCTIONS

User Controls

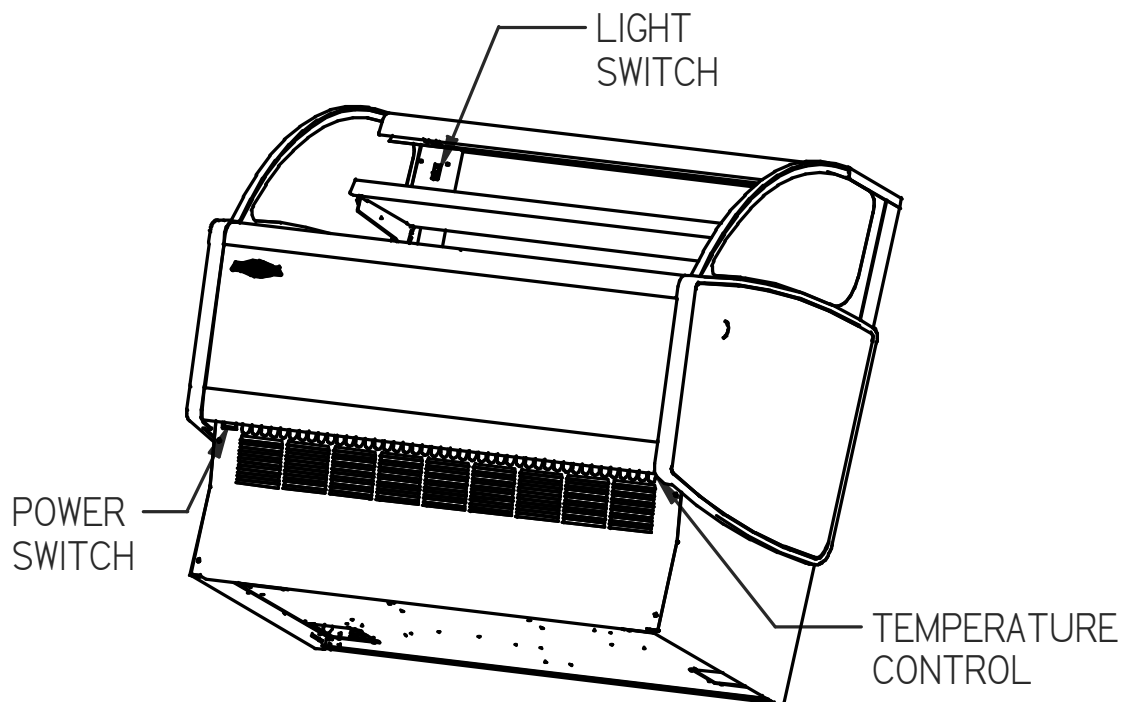

Power Switch

The unit has a power switch that turns off power to the entire unit, including the condensate evaporator and the lights. This switch is located behind a lift up panel on the unit base.

Light Switch

The unit has a light switch that turns on and off the interior lights of unit. This switch is located below the lift up panel on the unit base.

Temperature Control

This controls the temperature of the display interior of case.

Temperature Control Functions

Electronic Control

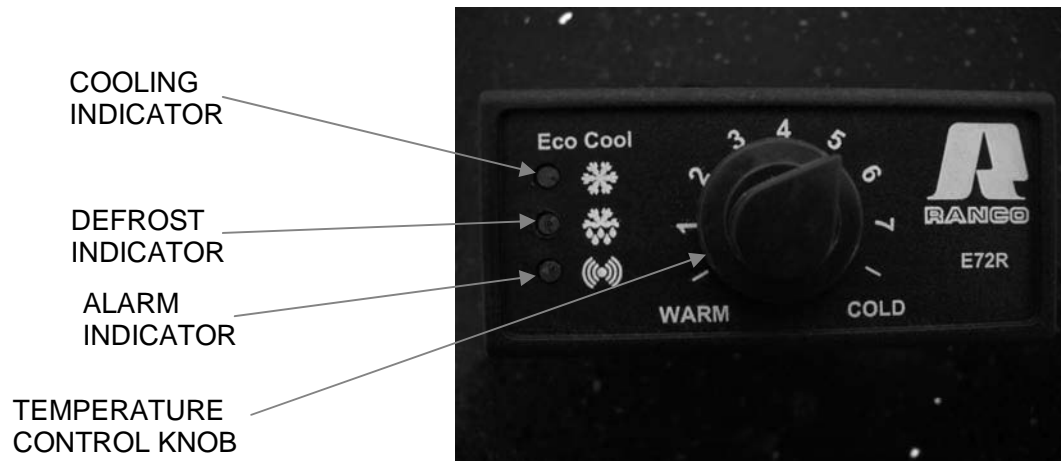

Temperature Control Knob

This controls the temperature of the display interior of case.

-OFF: Turning the control counterclockwise to the “WARM” setting is an Off position, this position turns the refrigeration off and all indicator lights will also be off at this setting.

-ON; The control will be on from the warmest setting at “1” and the coldest setting at “COLD”.

Cooling light

This light will be on when control requires refrigeration to be on. The compressor / condensing unit should be running to cool the case.

Defrost light

This light will be on when control when refrigeration is defrosting allowing ice to melt off of evaporator coil. The number of times and length of defrost will vary depending on case environment.

Alarm light

This light indicates that there is a problem with case or electronic control and service should be called.

Initial Start-Up

After all the checks outlined in the installation section of this manual have been made, the case is ready to be put into service. Turn on the Power at the breaker box and flip the Power Switch and Light Switch on unit to the on position.

At start up from a warm unit, it is recommended that the temperature control is set at a warm setting, such as 1 on the dial. After the unit has gone through several cycles, turn the control to a mid range setting, then to a colder setting if necessary to maintain desired product temperature



NOTICE: This refrigerated display case is designed to operate in a maximum environment of 75 DEG. F and 55% relative humidity. Exceeding these limits will cause poor case performance and excessive sweating.

Placing Product into Case

- Do not exceed 75 pounds of weight per shelf. Heavy product should be distributed evenly across the entire shelving area.
- Determine desired shelving location before placing product in case. Product must be removed to readjust shelf location.
- Allow a minimum of 2" between top of product and bottom of shelf.
- Do not overhang the front or rear of shelves with product. Improper clearance in front and rear of shelf will block the refrigerated airflow and will cause product loss.
- Do not block the slots along the front and rear air discharge slots. Covering these slots will block the refrigerated airflow and could cause product loss.
- The display deck is removable for cleaning and can become dislodged in shipment. To ensure proper airflow and performance of the case, make sure that the display deck is pushed completely down.
- Allow refrigerated models to run for at least two hours before placing pre-chilled product into unit.



NOTICE: CASE MUST BE STOCKED WITH PRE-CHILLED PRODUCT ONLY.



NOTICE: This refrigerated display case is designed to operate in a maximum environment of 75 DEG. F and 55% relative humidity. Exceeding these limits will cause poor case performance and sweating of glass panels.

ATTENTION:

- Federal refrigerated display cases are designed to operate in a maximum environment of 75 DEG. F and 55% relative humidity. Exceeding these limits could cause poor case performance and sweating of glass panels.

LEAVE 1/2" GAP BETWEEN PRODUCT
TO ALLOW AIR FLOW AROUND PRODUCT

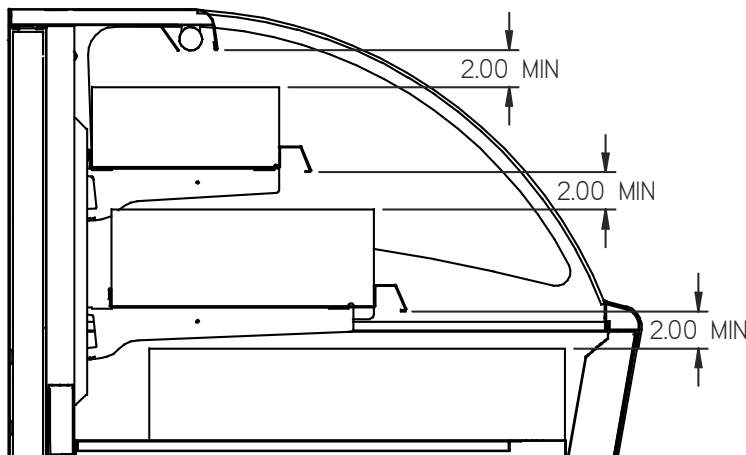

MAINTENANCE

Light Bulb Replacement

1. All light fixtures use a spring-loaded socket at one end. To remove the bulb push the bulb towards the spring-loaded socket until the opposite ends drops out of the socket.
2. The bulb is inside a clear shatter proof tube with a black plastic cap on each end. Be careful not to allow bulb to slide out of shatter proof tube.
3. Reinstall new bulb in to the existing shatter proof tube and reuse black plastic end caps. Reinstall bulb assembly in the same manner as described in the Bulb Removal Procedure. Be sure bulb is secure in bulb receptacles

Note: Be sure to use a direct equivalent to the original bulb.

PERIODIC MAINTENANCE

Cleaning Condenser Coil (All Self Contained Refrigerated Units)

It is very important that the Condenser coil is cleaned twice per month to insure proper refrigeration performance and to prevent compressor failure. Failure to clean condenser coil will void Condenser warranty.

1. Disconnect power to the unit.
2. Remove the front panel located on the front bottom of unit by removing the (4) front panel retaining screws.
3. Carefully vacuum the front surface of condenser coil. Take care not to bend coil fins with vacuum cleaner nozzle.
4. Reinstall front panel and retaining screws.

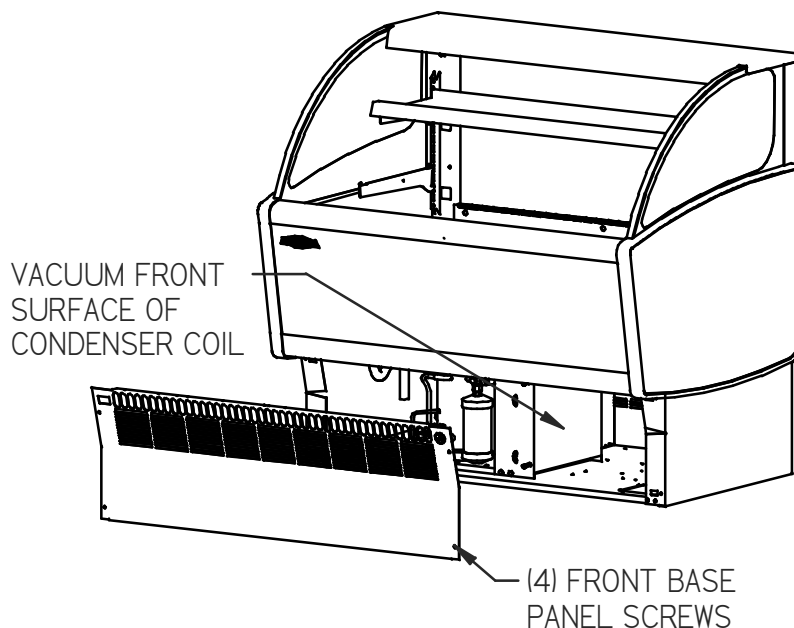

CLEANING INSTRUCTIONS

Daily Cleaning

The case should be cleaned thoroughly, as described in the weekly cleaning section, before it is used for the first time.



NOTICE: Avoid splashing or soaking any electrical components with water to prevent electrical damage to the case.



NOTICE: Shut off lights and power switches and remove all product from case. Allow sufficient time for the unit to reach room temperature before proceeding with cleaning.



NOTICE: Remove all product from case before proceeding with cleaning procedure.



NOTICE: Acrylic end panels and top panel require special washing procedures to prevent hazing and yellowing of material. Read cleaning of end panel and top panel procedure carefully.



NOTICE: This case is not designed to be cleaned by flushing.

Note: For major spills or foreign material buildup perform the weekly cleaning instructions.

1. (If Supplied With Optional Rear Doors.) Clean all foreign materials from the door opening and clean both sides of the doors with a damp cloth
2. Wipe complete interior and exterior of case using a damp cloth.
3. Clean both sides of end glass panels using any common window cleaner.

Weekly Cleaning

This procedure is recommended on a weekly basis. It may need to be performed more often if necessary to maintain a clean, sanitary case. The case should be cleaned to this procedure before using the first time.



NOTICE: Avoid splashing or soaking any electrical components with water to prevent electrical damage to the case.



NOTICE: Shut off lights and power switches and remove all product from case. Allow sufficient time for the unit to reach room temperature before proceeding with cleaning.



NOTICE: Remove all product from case before proceeding with cleaning procedure.



NOTICE: This case is not designed to be cleaned by flushing.

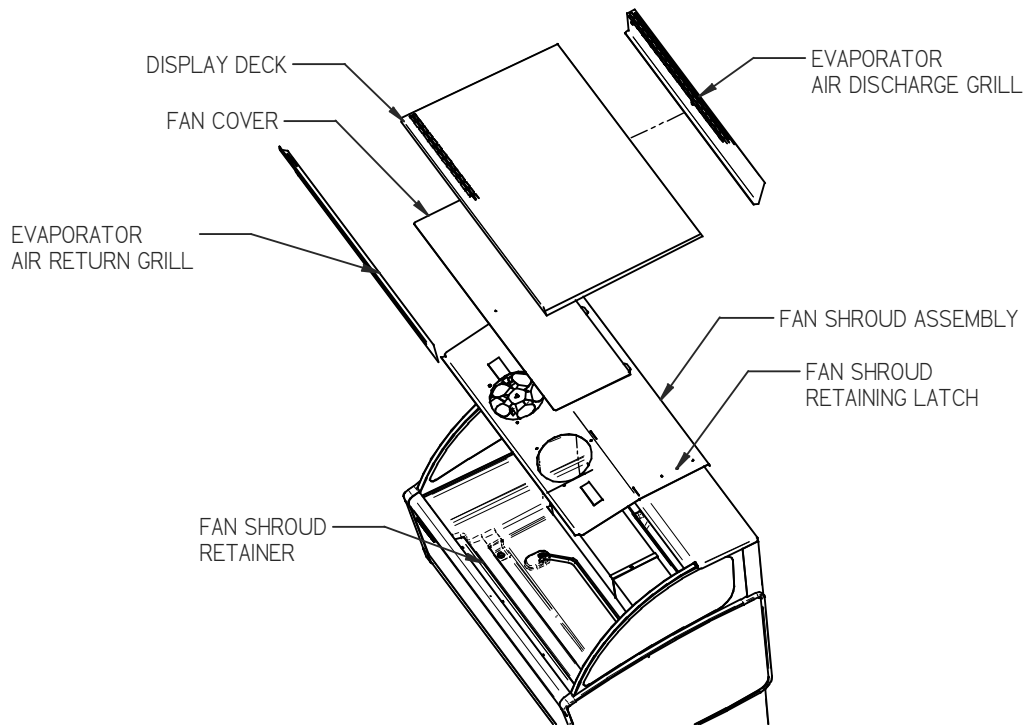

1. If supplied with rear door option remove both rear doors as described in the “Door Removal” section of this manual.
2. Remove shelving from unit as described in the “Shelving Installation and Removal” section of this manual. Remove all interior shelving as described in the shelving installation and removal section of this manual.
3. Remove both shelf standards from interior of case by removing the (2) thumbscrew from top and bottom.
4. Lift the display deck up and out of evaporator tub.
5. Lift the grab tab of the fan cover and slide the fan cover tabs out of the fan shroud assembly slots. and.
6. Remove the fan shroud assembly by lifting (4) black tabs up on each end of evaporator coil. Lift the rear of the evaporator fan shroud and slide the front lip out of the fan shroud retainer. Reach in and unplug the evaporator fan motor cord. Remove evaporator fan shroud.
7. Clean the entire interior of the case using warm soapy water. Wipe off all soapy water with a damp cloth and allow to dry. (DO NOT use solvents such as Acetone, Benzene, Carbon Tetrachloride, and Lacquer Thinners)

NOTE: Depending on the amount of usage and spillage of foreign material, some fasteners may have to be removed and parts disassembled to allow proper cleaning of the unit.

8. Clean all shelves, shelf support bars, shelf light housings, shelf brackets, and display pans using warm soapy water and a brush. Rinse thoroughly and allow to dry.
9. If supplied with rear door option clean all foreign material from inner and outer rear door tracks and clean them and both sides of the doors using warm soapy water and a brush. Apply a light film of lubricant such as PAM to door tracks to make the doors operate smoother.
10. Clean end glass panels using any common window cleaner.
11. Reassemble the case in reverse order.

SALE & DISPOSAL

Owner Responsibility

If you sell or give away your Federal Industries case you must make sure that all safety labels and the Installation-Service Manual are included with it. If you need replacement labels or manuals, Federal Industries will provide them free of charge. Contact the customer service department at Federal Industries at (800) 356-4206.

The customer service department at Federal Industries should be contacted at the time of sale or disposal of your case so records may be kept of its new location.

If you sell or give away your Federal Industries case and you evacuate the refrigerant charge before shipment. Federal Industries recommends that the charge be evacuated into a recovery system to prevent the possibility of HFC's from being released into the atmosphere.

SERVICE INFORMATION

<p>CAUTION RISK OF ELECTRIC SHOCK</p> <p>DISCONNECT POWER BEFORE SERVICING UNIT</p>
--

Before any service work is performed on the case, make sure all power is disconnected to the case.

Service problems or request for repair parts from authorized service agencies, trained service personnel, or owners should be referred to:

CUSTOMER SERVICE DEPARTMENT
Federal Industries
P.O. Box 290
Belleville, WI 53508
Toll Free: (800) 356-4206 / WI Phone (608) 424-3331
Fax: (608) 424-3234

Pre-Service Checklist

You may avoid the cost and inconvenience of an unnecessary service call by first reviewing this checklist of frequently encountered situations that can cause unsatisfactory case performance.



CAUTION: Before servicing case turn off power at the main breaker of fuse box.

Case Does Not Operate

- Check for disconnected power supply.
- Check for tripped breaker or blown fuse.
- Check that power switch is on.

Lights Do Not Operate

- Check that light switch is on.
- Be sure light is properly seated in the sockets.

If supplied with shelf light option

- Check that shelf light cord(s) are tight in the sockets.
- Plug unused light sockets with socket cap provided with socket.

Case Temperature Too Warm

- Check that the cold air inlet and outlet slots are not blocked.
- If supplied with rear door option be sure that the rear doors are closed and tightly sealed.

- Check for a blocked or dirty condenser coil fins.
- Check cold airflow. Lack of adequate cold airflow could be a defective evaporator fan or blocked evaporator coil. Check that paper or foreign material is not blocking evaporator. If the evaporator coil is blocked due to excessive frost, turn the power switch “off” position for approximately one hour to defrost.
- Check that the display pan(s) are installed properly. Slots must be towards the front and is marked front
- Is the case installed properly to allow adequate air flow to and from condenser.

Special Service Situations

There are rare occasions when the refrigerant charge must be evacuated from a case in order to perform service work. In those situations, Federal Industries recommends that the refrigerant charge be evacuated into a recovery system to prevent the possibility of hydrofluorocarbons (HFC's) from being released into the atmosphere.

If moisture or liquid is observed around or under a Federal Industries case, an immediate investigation should be made by qualified personnel to determine the source of the moisture or liquid. The investigation made should determine if the case is malfunctioning or if there is a simple housekeeping problem.

Moisture or liquid around or under a case is a potential slip/fall hazard for persons walking by or working in the general area of the case. Any case malfunction or housekeeping problem that creates a slip/fall hazard around or under a case should be corrected immediately.

Refrigeration & Electrical Data

MODEL	SELF CONTAINED				REMOTE		
	404A REFRIG.	VOLTAGE	AMPERAGE	CORD STYLE	VOLTAGE	AMPERAGE	CORD STYLE
LPRSS3	2 LBS	120/60/1	15	20AMP NEMA 5-20	120/60/1	3	15AMP NEMA 5-15
LPRSS4	3 LBS	120/60/1	15	20AMP NEMA 5-20	120/60/1	3	15AMP NEMA 5-15
LPRSS5	4 LBS	230/60/1	10	15AMP NEMA 6-15	120/60/1	2	15AMP NEMA 5-15
LPRSS6	4 LBS	230/60/1	12	15AMP NEMA 6-15	120/60/1	2	15AMP NEMA 5-15

Electronic Control Operation

This unit is equipped with an Invensys – Ranco temperature control. The control parameters are set at the factory and cannot be manually changed in the field. Control parameter changes can only be made by downloading a new set of parameters via a program chip supplied by Federal Industries. The pre set control parameters are listed on the chart in the Settings Chart below.

Operation

The control uses two sensors, one located in the air stream and one located on the evaporator coil. The sensor located in the air stream is referred to as the temperature control sensor. The sensor located on the evaporator coil is referred to as the coil sensor.

The temperature control sensor is located inside the center tower at the top. The sensor location is critical for proper operation on the unit. Do not move or relocate this sensor.

The coil sensor is strapped to the evaporator coil. This sensor location is critical for proper operation of the unit. Do not move or relocate this sensor.

The temperature control is set to cut in at 38 degrees F. The Temp control cuts out at 16 degrees F at the coldest setting 'COLD' and 28 degrees F at the warmest setting, '1' on the control dial.

The temp control turns off the refrigeration system when the control is turned all the way counterclockwise.

Defrost Cycle

The Ranco control is programmed to initiate defrost via two different methods. There are 3 programmed defrost cycles in the case which will initiate a defrost cycle every 8 hours. The unit does not have a time clock so the defrost cycles cannot be set for any specific time of day.

The unit also has an 'On demand' defrost feature that will initiate a defrost when the temperature differential between the evaporator temperature and the air temperature is more than 12 degrees for 5 minutes after 30 minutes into the refrigeration cycle. Once initiated the defrost cycle will terminate when evaporator coil sensor reaches 45 degrees F.

Control Factory Settings

The control parameters are set at the factory and cannot be manually changed in the field. Control parameter changes can only be made by downloading a new set of parameters via a program chip supplied by Federal Industries

E3380

11/10/11

TAB	REF	PARAMETER DESCRIPTION	FACTORY DEFAULT	LPRSS
CONFIGURATION	1	Controller Operation Temperature Units	Fahrenheit	
	4	Defrost Termination Method	Evaporator Sensor	
SET-POINTS	8	Cut-In Warm	14°F	38°F
	9	Cut-Out Warm	-4°F	28°F
	10	Cut-In Cold	-2°F	38°F
	11	Cut-Out Cold		16°F
	13	Comp Minimum On Time	1 min	5 min 0 sec
DISPLAY	15	Defrost Display Lock (display indication during defrost)	Lock Display at Temp. reading prior to defrost.	
DEFROST	38	Defrost Termination Temperature	41°F	45°F
	39	Time to First Defrost (hh:mm)	6 hr	8 hr
	40	Time to subsequent Defrost	6 hr	8 hr
	41	Defrost Max Duration	1 hr	30 min

Control Display

The control display is located in the unit base. It is programmed to display the current temperature from the control sensor located inside the center tower at the top.

Refrigeration Operation

Self Contained Models

R404A SELF CONTAINED REFRIGERANT CHARGE			
LPRSS3 - 2 lbs	LPRSS4 - 3 lbs	LPRSS5 - 4 lbs	LPRSS6 - 4 lbs

The self-contained models are shipped from the factory with a completely operational 404A refrigeration system and require no modifications or adjustments upon installation. Case must be installed as per the installation section of this manual to provide proper condensing air cooling.

The unit temperature is controlled by the Electronic control outlined in the control section of this manual.
 Note: The condenser fan runs continuously.

Remote Models Use pressure gauges to set pressure control.

Refrigeration R404 Charge	CHARGED IN FIELD
Remote Low Press. Switch Cut In	50 psi
Remote Low Press. Switch Cut Out	15 psi
Adjustable Head Master	200 psi
Remote High Press. Switch Cut Out	400 psi

The remote models are designed to use 404A refrigerant and shipped from the factory with the evaporator coil, expansion valve, sight glass, and refrigerant solenoid valve. Filter Drier must be installed in field. Electronic control runs identical to the Self Contained models except the electronic control opens and closes a refrigeration solenoid valve located on the suction line instead of turning on and off a compressor. The solenoid valve closes and shuts off the refrigeration flow to the unit and initiates a pump down cycle. This will allow the remote low pressure switch to open and shut off remote compressor. The condensing unit and pressure controls are optionally supplied from the factory for remote location installation. The condensing unit must be mounted and wired by the installer. The high low pressure switch must be wired in series with the compressor power supply as shown in diagram below.

1. Mount condensing unit indoors as close to the remote display case as practical. The refrigeration line should be as short as possible and must not exceed 30 feet.
2. All refrigeration and/or electrical materials between the condensing unit and display case are to be supplied by installing contractor.
3. Route properly sized and designed refrigeration lines from the condensing unit to the cabinet. Horizontal suction lines should be pitched downward towards the condensing unit at least ½" per 10' run to aid the oil drainage. A "P" trap must be installed in the suction line at the foot of every riser to insure oil return. Dry nitrogen must be used to flow through tubing while brazing refrigeration lines.
4. Suction line must be insulated the entire length with Armaflex (or equivalent). Do not run liquid line inside insulation with suction line.
5. The remote high/low-pressure control must be mounted, wired and set pressures by the installer.
6. Leak check condensing unit, cabinet, and all connecting tubing. Cabinet and condensing unit tubing should be checked to insure no leaks occurred during shipping or from rough handling.

Make certain all refrigeration valves are opened and evacuate system to 500 microns. Charge the system with refrigerant type specified on the data plates.

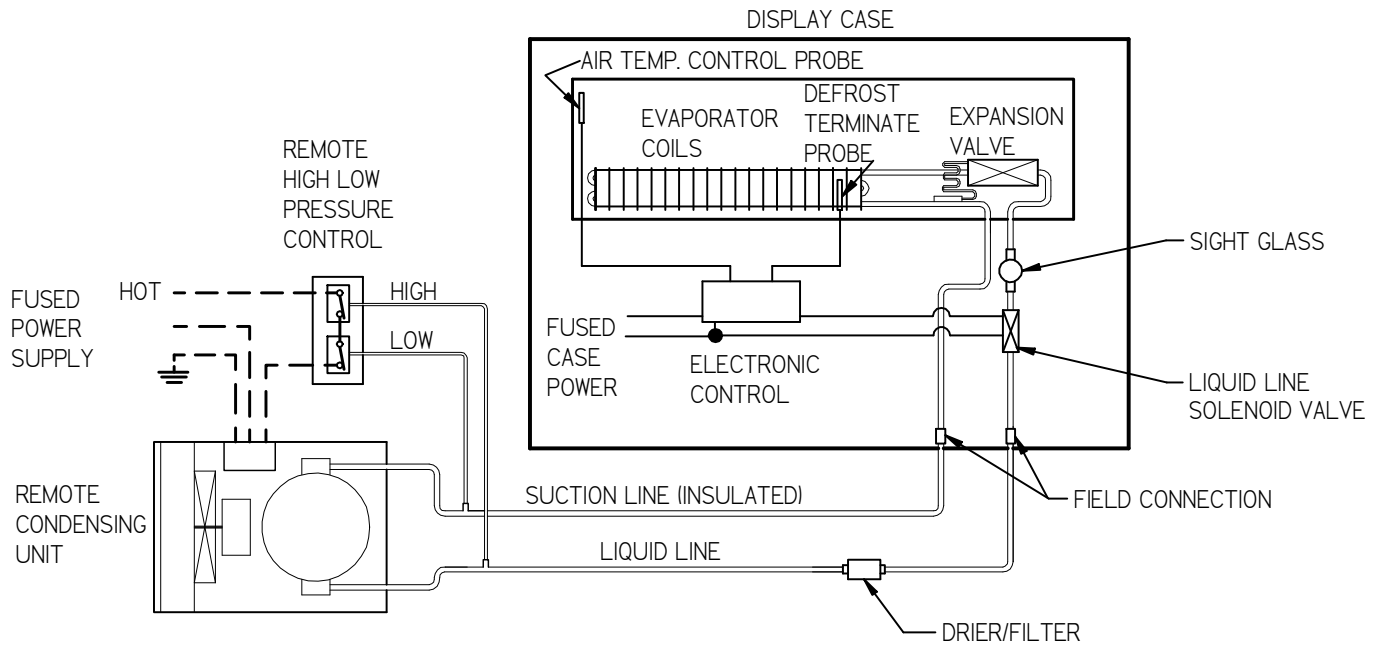

Main Wiring Diagrams

SELF CONTAINED

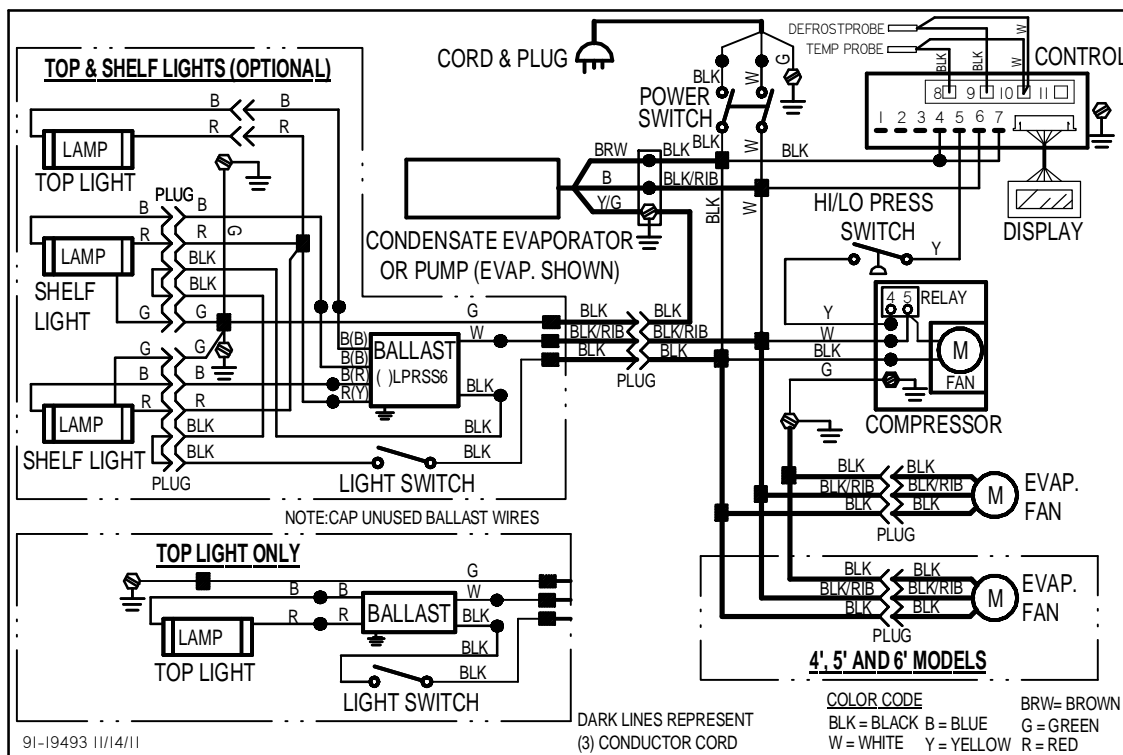

REMOTE

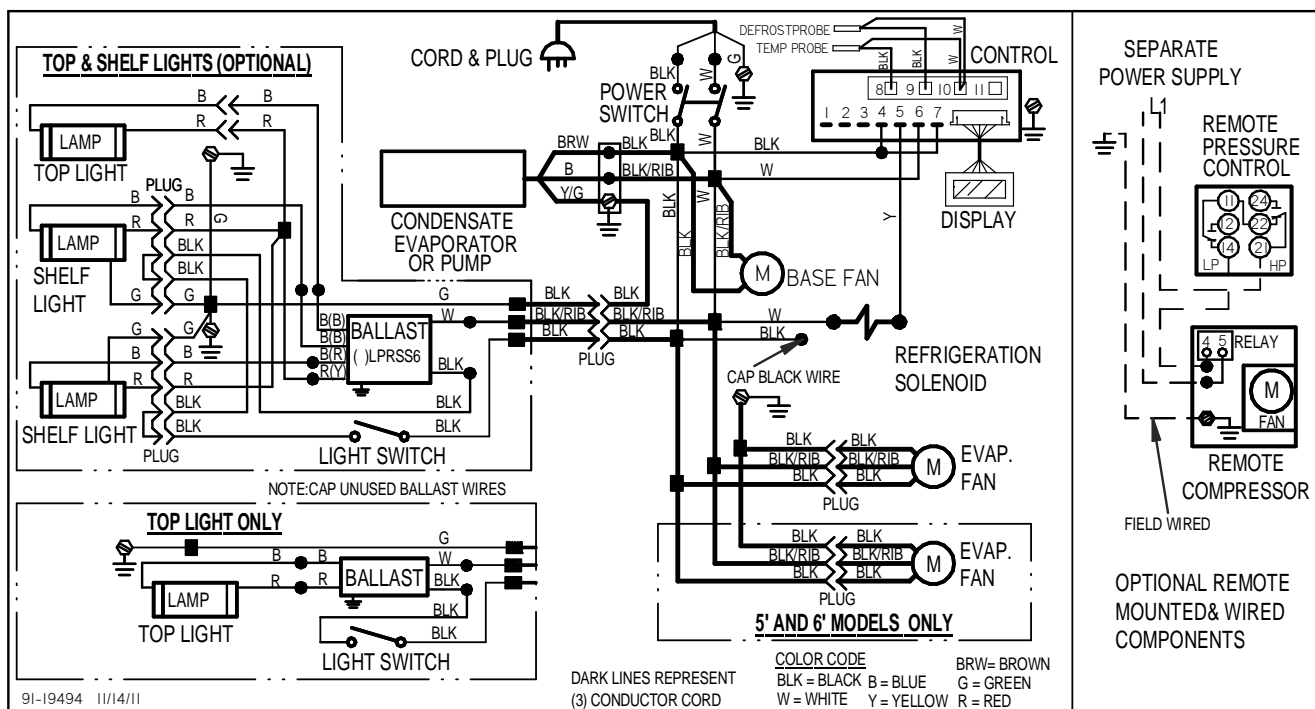

Replacement Parts

REFRIGERATION	LPRSS3 120V	LPRSS4 120V	LPRSS5 240V	LPRSS6 240V
Condensing Unit (SC) & (Remote)	30-17726	30-17726	30-17887	30-17888
Evaporator Coil	33-17700-1	33-17700-2	33-17700-3	33-17700-4
TXV Expansion Valve	32-19420		32-19419	32-19416
Filter Drier	32-12626			
Site Glass	32-54010			
Temperature Control	32-19445			
Temperature Probe	32-19094			
Control Display	32-19446			
Digital Display Ribbon Cable	32-19093			
Pressure Control	32-51009			
Evaporator Fan Motor Self Cont.	41-16025		41-17811	
Evaporator Fan Motor Remote	41-16025			
Evaporator Fan Blade	72-11450	72-17987	72-11450	72-11450
Latch Evaporator Housing to Coil	66-13640			
Condnsate Pump (Std 5 & 6)	47-15686		47-15687	
Condensate Base Fan Motor(Opt on Rem)	41-11628			
Condensate Base Fan Blade(Opt on Rem)	72-32507			
Condensate Pan Ass'y (Std 3 & 4)	SA5202		-	
Condensate Pan PTC Heater	40-19498		-	
Condensate Pan Wick	15-19469		-	
Condensate Drain Tube	06-17699		SA5210	
Thermometer	32-13662			
ELECTRICAL	LPRSS3 120V	LPRSS4 120V	LPRSS5 240V	LPRSS6 240V
Light Switch	41-11066			
Power Switch	41-18186			
Light Ballast (Top Light Only)	39-12902		39-12902	
Light Ballast (W/Opt.Shelf Lights)	39-12903		39-12903	39-12904
Light Bulb	42-11519	42-11069	42-11070	42-11071
Light Bulb Receptacle	42-10834			
Light Bulb Recept.Spring	42-10833			
Light Bulb Shatter Guard Tube	42-15639	42-30200	42-15641	42-15637
Light Bulb Shatter Tube Cap	78-12462			
Harness Ballast	43-17800			
Harness Ballast/Recept.(Optional)	43-17799			
Top Shelf light Cord (Optional)	43-17757-1			
Bottom Shelf light Cord(Optional)	43-17757-2			
Main Wire Harness	43-19492			
Power Cord	43-30818		43-17839	
Wiring Diagram	91-19493 SC / 91-19494 REM			

PANELS	LPRSS3	LPRSS4	LPRSS5	LPRSS6
Glass End Clear	50-17701			
Glass End Reflective Left(Optional)	50-17701-1L			
Glass End Reflective Right(Optional)	50-17701-1R			
End Panel Mirror Int.Left(Optional)	SA4287-L			
End Panel Mirror Int.Right(Optional)	SA4287-R			
Cover Top Black	M15910-1	M15910-2	M15910-3	M15910-4
Cover Top Stainless (Optional)	M15910-1A	M15910-2A	M15910-3A	M15910-4A
End Glass Trim Front Black	M15959			
EndGlass Trim Stainless (Optional)	M15959-A			
End Panel Ass'y Left (color needed)	SA4361-L			
End Panel Ass'y Right (color needed)	SA4361-R			
Pad 1x1 End Panel (Dual Lock 250)	77-17849			
Pad 1x1 Cabinet (Dual Lock 170)	77-17848			
SHELVING	LPRSS3	LPRSS4	LPRSS5	LPRSS6
Shelf Top Black	M15967-1	M15967-3	M15967-5	M15967-7
Shelf Bottom Black	M15967-2	M15967-4	M15967-6	M15967-8
Shelf Top Stainless (Optional)	M15967-1A	M15967-3A	M15967-5A	M15967-7A
Shelf Bottom Stainless (Optional)	M15967-2A	M15967-4A	M15967-6A	M15967-8A
Glass Shelf Top (Optional)	52-17991-1	52-17991-2	52-17991-3	52-17991-4
Glass Shelf Bottom (Optional)	52-17992-1	52-17992-2	52-17992-3	52-17992-4
Glass Shelf Retainer(Optional)	SA4091			
Shelf Bracket Top	67-17732-1			
Shelf Bracket Bottom	67-17732-2			
Shelf Standard	M14679-A			
MISCELLANEOUS OPTIONS	LPRSS3	LPRSS4	LPRSS5	LPRSS6
Rear Door Inner Black(Optional)	53-17912-1	53-17912-2	53-17912-3	53-17912-4
Rear Door Outer Black (Optional)	53-17913-1	53-17913-2	53-17913-1	53-17913-1
Rear Door Top Track (Optional)	57-17910-1	57-17910-2	57-17910-3	57-17910-4
Rear Door Bottom Track (Optional)	57-17909-1	57-17909-2	57-17909-3	57-17909-4
Rear Door Jamb (Optional)	57-17911			
Security Night Cover Panel (Optional)	M16107-1	M16107-2	M16107-3	M16107-4
Security Night Cover Latch (Optional)	66-11727			
Night Curtain Black	65-19459	65-19460	65-19458	65-19300
Step Riser Top (Optional)	SA4367-1	SA4367-2	SA4367-3	SA4367-4
Step Riser Bottom (Optional)	SA4367-5	SA4367-6	SA4367-7	SA4367-8