

E3745  
07/29/16



*The Signature of Quality®*

# RSSL378, RSSL478, RSSL578, RSSL678

Self-Contained & Remote Models

## INSTALLATION & OPERATION INSTRUCTIONS

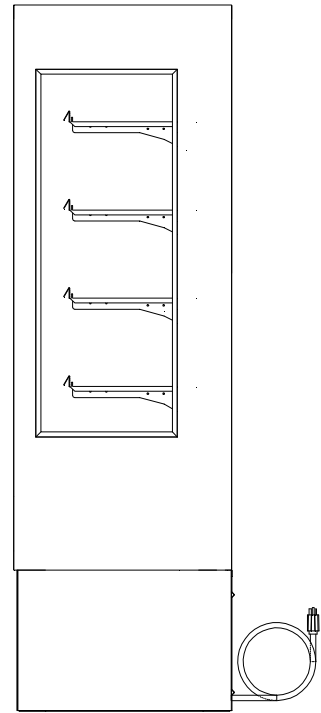
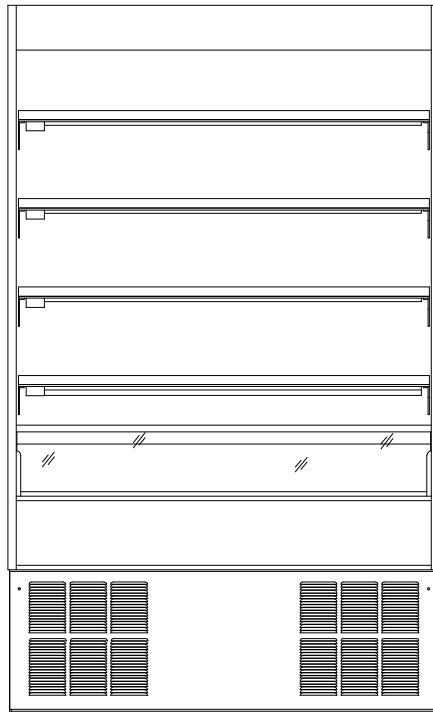
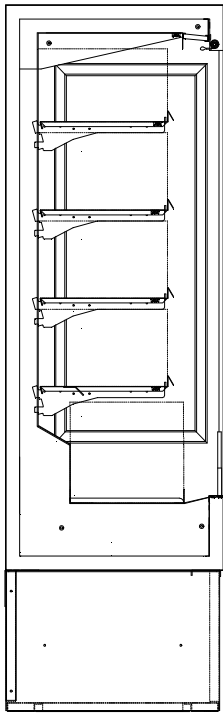

### **KEEP THIS MANUAL FOR FUTURE REFERENCE**

Engineering and technical data are subject to change without notice.

FEDERAL INDUSTRIES  
Toll Free 1(800) 356-4206

215 FEDERAL AVE  
WI Phone (608) 424-3331

Belleville, WI 53508  
Fax: (608) 424-3234

# CONTENTS

<b>INTRODUCTION</b> .....	<b>1</b>
<b>WARNING LABELS &amp; SAFETY INSTRUCTIONS</b> .....	<b>2</b>
<b>PRE-INSTALLATION PROCEDURES</b> .....	<b>3</b>
Inspection For Shipping Damage.....	3
<b>INSTALLATION INSTRUCTIONS</b> .....	<b>3</b>
Locating The Display Case .....	3
Grill Removal .....	3
Removing Case From Shipping Skid.....	4
Removing Packaging Material.....	4
Leveling The Case .....	4
Condensate Evaporator .....	4
Lights.....	5
<b>ELECTRICAL CONNECTION &amp; GROUNDING INSTRUCTIONS</b> .....	<b>6</b>
Electrical Supply Wiring.....	6
Grounding Requirements.....	6
Optional permanent connection.....	6
<b>OPERATING INSTRUCTIONS</b> .....	<b>7</b>
User Control RANCO.....	7
Using The Electronic Control.....	7
Alternate User Control CAREL .....	7A
Using The Electronic Control.....	7A & 7B
Initial Start-Up.....	8
Light Switch & Lights.....	8
Light Replacement.....	8
Digital Display.....	8
Placing Product In Case.....	8
Dual Pressure Control.....	9
Shelves.....	10
Periodic Maintenance.....	10
<b>CONTROL OPERATION</b> .....	<b>11</b>
Electronic Control.....	11
Operation.....	11
Defrost Cycle.....	12
Control Factory Setting.....	12
Control Display.....	13
Minimum Run Timer Feature.....	13
Maximum Run Timer Feature.....	13
<b>REFRIGERATION OPERATION</b> .....	<b>13</b>
Self Contained Operation.....	13
Remote Operation.....	14
<b>CLEANING INSTRUCTIONS</b> .....	<b>15</b>
Daily Cleaning.....	15
Weekly Cleaning.....	16

<b>SERVICE INFORMATION.....</b>	<b>17</b>
Pre-Service Checklist.....	18
Special Service Situations.....	19
<b>SALE &amp; DISPOSAL .....</b>	<b>19</b>
Owner Responsibility .....	19
<b>REFRIGERATION &amp; ELECTRICAL DATA .....</b>	<b>20</b>
RSSL378.....	20
RSSL478.....	21
RSSL578.....	22
RSSL678.....	23
<b>REPLACEMENT PARTS.....</b>	<b>24</b>
RSSL378.....	24
RSSL478.....	25
RSSL578.....	26
RSSL678.....	27
<b>RSSL DISPLAY AREA &amp; VOLUME.....</b>	<b>28</b>
<b>WIRING DIAGRAMS.....</b>	<b>29</b>
RSSL3, 4 120V - SELF CONTAINED.....	29
RSSL5, & 6 208-240V – SELF CONTAINED.....	30
RSSL3, 4, 5, 6 120V REMOTE.....	31
RSSL3, 4, 5, 6 FLUORESCENT TOP & OPTIONAL SHELF LIGHTS.....	32
RSSL3, 4, 5, 6 LED TOP LIGHTS.....	33
RSSL3, 4 LED OPTIONAL TOP & SHELF LIGHTS.....	34
RSSL5, 6 LED OPTIONAL TOP & SHELF LIGHTS.....	35

---

---

# INTRODUCTION

---

---

Thank you for purchasing a Federal Industries Merchandiser. This manual contains important instructions for installing and servicing the RSSL, Refrigerated Self-Service Merchandisers. A repair parts list is also included in the manual. Read all of these documents carefully before installing or servicing your case.



## NOTICE

**Read this manual before installing your case. Keep this manual and refer to it before doing any service on the equipment. Failure to do so could result in personal injury or damage to the case.**



## NOTICE

**Installation and service of the electrical components in the case must be performed by a licensed electrician.**

The portions of this manual covering components contain technical instructions intended only for persons qualified to perform electrical work.



## DANGER

**Improper or faulty hookup of electrical components in the case can result in severe injury or death.**

**All electrical wiring hookups must be done in accordance with all applicable local, regional, or national standards.**

**NOTE: UNIT MUST BE GROUNDED**

## SERIAL NUMBER

Record the model and serial numbers of the case for easy reference. Always refer to both model and serial numbers in your correspondence regarding the case.

Case Model \_\_\_\_\_ Serial Number \_\_\_\_\_

This manual cannot cover every installation, use, or service situation. If you need additional information, call or write us:

**WARRANTY/TECHNICAL SERVICE DEPARTMENT**

**Federal Industries**

**P.O. BOX 290**

**Belleville, WI 53508**

**Toll Free (800) 356-4206 / WI Phone (608) 424-3331**

---

---

# WARNING LABELS AND SAFETY INSTRUCTIONS

---

---



This is the safety-alert symbol. When you see this symbol on your case or in the manual, be alert to the potential for personal injury or damage to your equipment.

Be sure you understand all safety messages and always follow recommended precautions and safe operating procedures.



## NOTICE TO EMPLOYERS

**You must make sure that everyone who installs, uses, or services your case is thoroughly familiar with all safety information and procedures.**

Important safety information is presented in this section and throughout the manual. The following signal words are used in the warning and safety messages:

**DANGER:** Severe injury or death will occur if you ignore the message.

**WARNING:** Severe injury or death can occur if you ignore the message.

**CAUTION:** Minor injury or damage to your case can occur if you ignore the message.

**NOTICE:** This is important installation, operation, or service information. If you ignore the message, you may damage your case.

---

---

The warning and safety labels shown throughout this manual are placed on your Federal Industries case at the factory. Follow all warning label instructions. If any warning or safety labels become lost or damaged, call our customer service department at 1(800) 356-4206 for replacements.

---

---

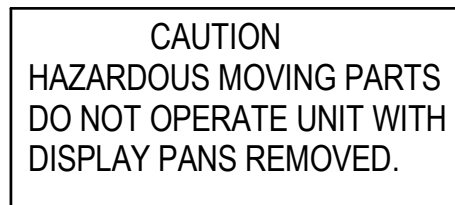
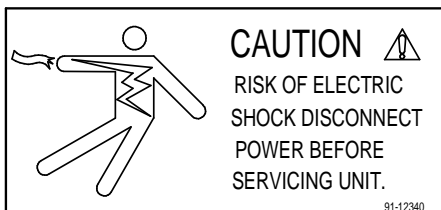

*This label is located on the back of the display case and on the front of the case behind the access panel.*

*This label is located below the display pan.*

---

---

# PRE-INSTALLATION PROCEDURES

---

---

## Inspection For Shipping Damage

You are responsible for filing all freight claims with the delivering truck line. Inspect all cartons and crates for damage upon arrival. If there is damage to shipping crates, cartons, or if a shortage is found, note this on (all copies) of the Bill Of Lading prior to signing.

If damage is discovered when the case is uncrated, immediately call the delivering truck line and follow-up the call with a written report indicating concealed damage to your shipment. Ask for an immediate inspection of your concealed damaged item. Crating material must be retained and shown to the inspector from the truck line.

---

---

# INSTALLATION INSTRUCTIONS

---

---

## Locating the Display Case      NOTE: This case is designed for indoor use only.

The case should be **located** where it is not subjected to the direct rays of the sun, heating ducts, grills, radiators, or ceiling fans, nor should it be located near open doors or main door entrances. Avoid locations where there is excessive air movement or air disturbances and avoid high humidity locations such as near cases with water misting or fogging devices.

The condenser air inlet is located in the front of the case. Do not block this inlet and do not locate the air inlet near a source of heat. Clearance of 6" minimum must be maintained at the back of the case for condenser discharge air. Clearance at the top of the case should also be at least 8".

Do not build this unit into an alcove and do not locate where condenser discharge air cannot escape or where warm condenser air is allowed to re-circulate.

## Grill Removal



**WARNING:**      **Electrical shock hazard. Do not operate unit with panels removed.**

Must remove front and rear base grills for merchandiser installation. The front base grill is secured with fast lead captive screws, and the rear base grill is secured with self threading screws.

Both base grills must be replaced after merchandiser installation. Base grills must be in place for proper operation of the merchandiser.

## **Removing Case From Shipping Skid**



**CAUTION:** If a Johnson bar or pry bar is used to move the case, make certain that the case is lifted under the welded steel frame, and not by the end panels of the case. Damage to the ends will result from lifting under the end panels.

Move the case as near as possible to the final location before removing it from the shipping skid. Having removed the front and rear compressor compartment grills. Remove the (three or four sets of bolts, nuts, and washers depending on case size) that secure the case to the shipping skid. Discard these bolts, nuts, and washers.

## **Removing Packaging Material**

Remove bubble wrap and packing material for all shelves, etc. If it is necessary to remove tape residue from various materials, use cleaning compounds recommended in the cleaning section of this manual.

## **Leveling the Case**

The case must be level for proper drainage of defrost water to the condensate evaporator or condensate pump.

Check the level of the case along the front rail and along the top of the display pan. Shim under the case frame as needed to level the case. It is recommended that the leveled case be sealed to the floor with an NSF Listed Sealant.

## **Condensate Evaporator**



**NOTICE:** Steam from the condensate evaporator may be visible around the base of the merchandiser during normal operation.

This merchandiser may be furnished with an electric condensate evaporator, or a electric condensate pump. Plumbing connections are not required, unless merchandiser is specifically ordered without a condensate evaporator or pump.

The condensate evaporator can be removed from the merchandiser and the condensate drain can be plumbed to a external drain to conserve energy. To remove the condensate evaporator, disconnect the wires at the condensate evaporator. This must be done by a qualified electrician.

This is an open merchandiser and can produce a large amount of condensate water. To ensure that adequate evaporator capacity is available, a high wattage heater is used.

Make sure that the condensate drain line has not been dislodged during shipment and that the drain trap terminates properly over the water reservoir.

## **Lights**

### **Standard Top Light**

The case comes with one standard top light which is internally wired to the power source. The light switch is located in the top light housing under the top canopy.

### **Optional Shelf Lights**

If optional shelf lights are furnished, make certain that the shelf light cords are completely inserted into the sockets in the back panel or arcing may result, causing damage to the plugs and sockets.

The ballasts used on this case allow removal of one or more shelf lights without affecting the remaining lights.

When plugging or unplugging light cords, turn the light switch to the "off" position.



---

---

# ELECTRICAL CONNECTION AND GROUNDING INSTRUCTIONS

---

---

## Electrical Supply Wiring



**DANGER:** Improper or faulty hookup of electrical components in the display case can result in severe injury or death.

**THIS CASE MUST BE GROUNDED**

## Optional Permanent Connection

- Only a licensed electrician must perform all case electrical connections.
- All electrical wiring hookups must be done in accordance with all applicable local, regional, or national electrical standards.
- A separate circuit for each display case is required to prevent other appliances on the same circuit from overloading the circuit and causing malfunction.
- The electrical service must be grounded upon installation.
- See the electrical data plate located at the rear of the case for circuit load and wire current capacity.
- Standard Base Electrical Connection: The electrical connection box is accessible from the rear of the case. Power Supply Wiring can be routed through the floor of the base frame or through the access hole in the rear of the unit. Remove electrical box cover to access electrical connections.

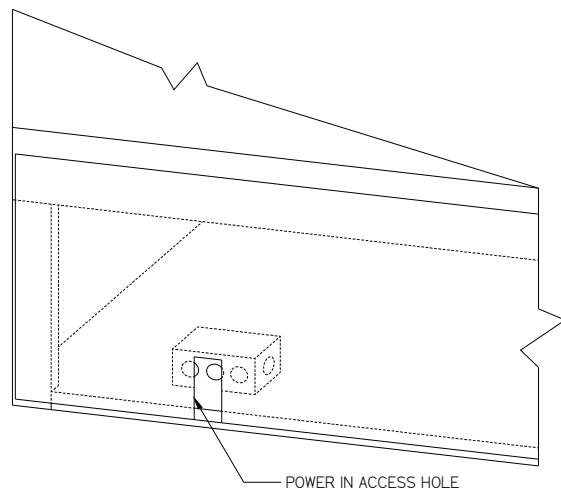
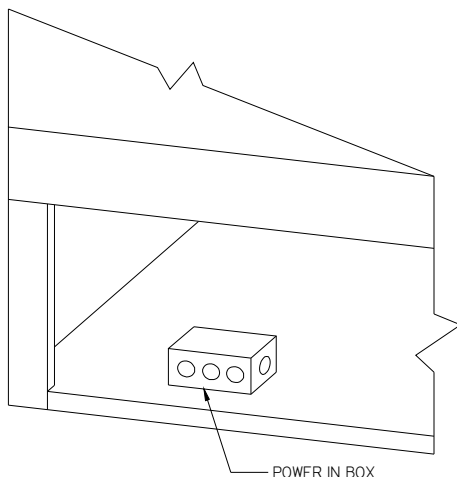

---

---

# OPERATING INSTRUCTIONS

---

---

## User Control RANCO



### **Using The Electronic Control**

This control is located behind the front base panel.

#### ***Temperature Control Knob***

This controls the temperature of the display interior of merchandiser.

-OFF: Turning the control counterclockwise to the “WARM” setting is an Off position, this position turns the refrigeration off and all indicator lights will also be off at this setting.

-ON; The control will be on from the warmest setting at “1” and the coldest setting at “COLD”

#### ***Cooling light***

This light will be on when control requires refrigeration to be on. The compressor / condensing unit should be running to cool the case.

#### ***Defrost light***

This light will be on when control when refrigeration is defrosting allowing ice to melt off of evaporator coil. The number of times and length of defrost will vary depending on case environment.

#### ***Alarm light***

This light indicates that there is a problem with case or electronic control and service should be called.

## Alternate User Control Carel

### USING THE ELECTRONIC CONTROL

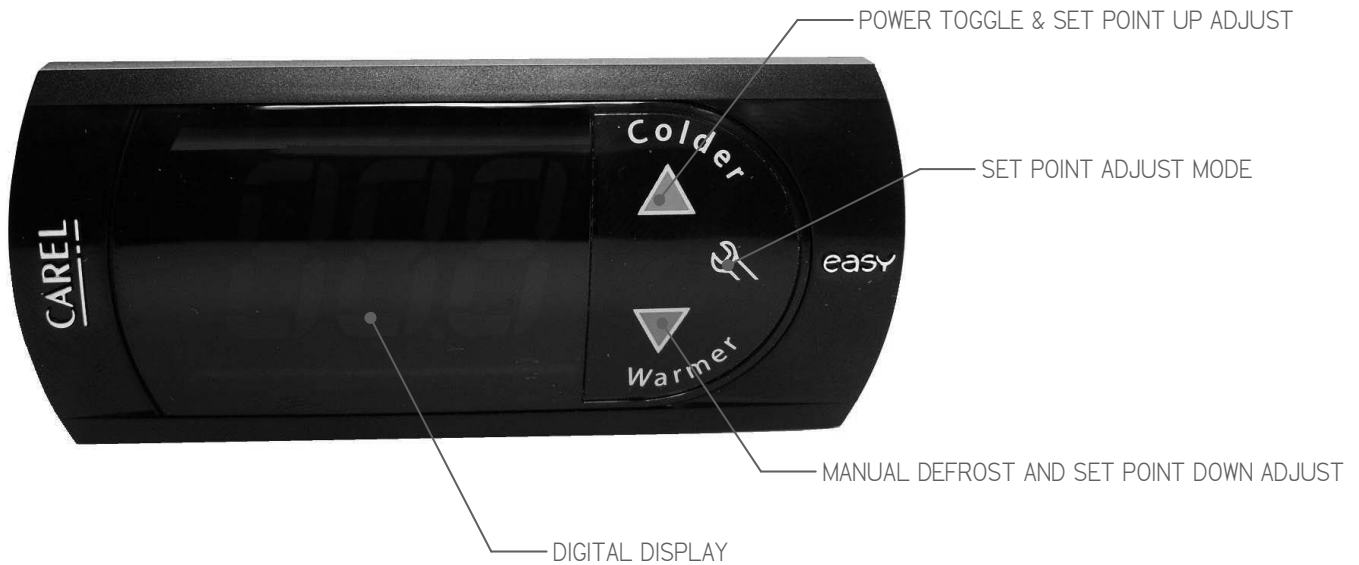

### Button and Display Overview

▲	<i>Press and hold this button for 3s to turn system on (if off) or off (if on). Also used to adjust set point when in set point adjust mode</i>
🔧	<i>Press to enter set point adjust mode, confirm set point changes, and mute alarms.</i>
▼	<i>Press and hold this button for 3 seconds to initiate a manual defrost (and cancel defrost if initiated), also adjusts set point down when in set point adjust mode</i>
▲ + ▼	<i>Press both buttons simultaneously to check air stream probe temperature. <b>This is not an indicator of product temperature.</b></i>

### Powering on control

To turn power on to the refrigeration system press and hold, for three seconds, the blue up arrow on the control's keypad. The keypad will read "On" while the button is depressed. When the system powers on, the display will read the current set point (a number "1" through "9"). The orange compressor run indicator will illuminate on the display.

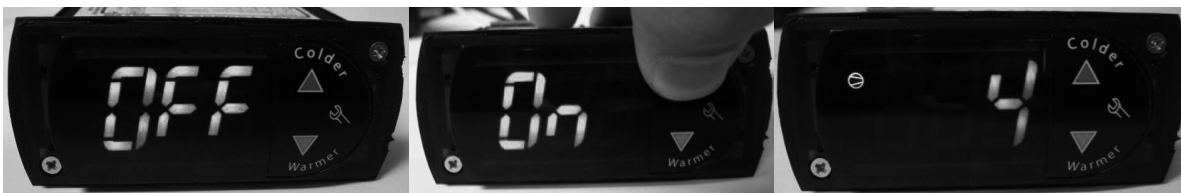

## **Adjusting the set point**

The set point is what determines how cold the display case will hold food and beverage. To adjust the set point press and hold the wrench button until the display begins to flash a number (three seconds). Then use the up and down arrows of the keypad to scroll through the set point options. There are nine (9) available set points, the higher the number of the set point name, the colder the display case will run, with setting “9” being the coldest and setting “1” being the warmest. Once you have chosen your desired setting press the wrench button again to confirm your choice.

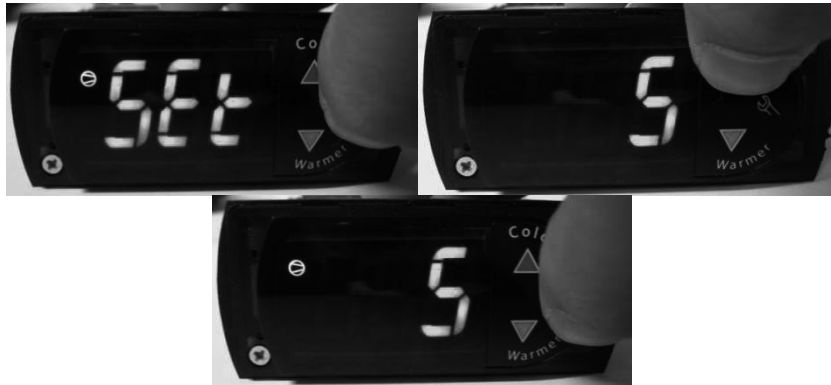

## **Entering manual defrost mode**

In order to initiate a manual defrost press and hold the red down arrow for 3s. The control will read “dEF” while the button is being held. The defrost is initiated when the orange snowflake appears on the control display.

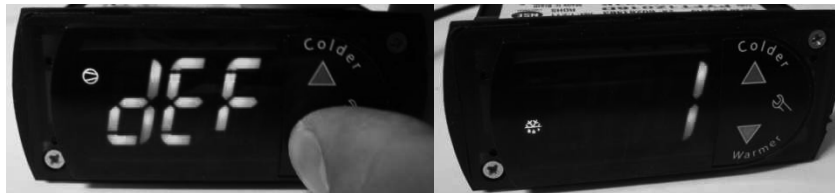

## **Error codes**

It is possible for error codes to be displayed on the control screen. In the event of a malfunction an alarm will sound and a red ringing bell will be displayed on the screen. An error code or codes will flash intermittently on the display. If there are multiple codes, the display will continuously cycle through them. The following photo shows error code “E0” as an example next to the red bell.



You may mute the alarm by pressing and releasing the wrench button. The red ringing bell and all error codes will still be displayed. When the fault is remedied the control will return to normal operation and will automatically clear the codes from the display.

## **Initial Start-Up**

After completing the items in the installation section of this manual. The case is ready to be put into service. On self-contained models, the service valves on the refrigeration system are back-seated when the unit leaves the factory.

RSSL cases are designed to operate at 40° to 41° F. under ambient conditions not to exceed 75° F. and 55% relative humidity.

Nearly all open refrigerated merchandisers operate better when loaded with product than when empty. If a check is made of the case operating temperatures, perform this check with product in the case.

Open refrigerated merchandisers are not intended as storage refrigerators and will not “pull down” room temperature products efficiently. Load case interior with pre-chilled product only.

## **Light Switch And Lights**

The light switch is located in the top light housing, under the canopy. This switch operates the interior lights only. If optional shelf lights are installed, they are also controlled by this switch.

## **Fluorescent Light Replacement**

The light fixtures use a spring-loaded socket on one end. To remove a light, push the bulb toward the spring-loaded socket until the opposite end drops out of the socket.

The bulbs are furnished with plastic safety light shields. Make certain the light shields are always in place to safeguard against bulb breakage.

When replacing lights, use direct equivalents to the original bulbs.

## **Digital Display**

This unit is equipped with a Ranco or CAREL temperature control with Digital Display. The Display shows discharge air temperature (not shelf temperature).

## **Placing Product In Case**

Do not overload the case with product to a point where the top air discharge grill or the bottom air intake grill are blocked, or where the air curtain created by the discharge air is blocked.

**LOAD CASE INTERIOR WITH PRE-CHILLED 38deg OR COLDER PRODUCT ONLY.**

## Dual Pressure Control (Self-Contained Models Only)

This device is a dual pressure control located on the left side of the base. The low pressure control portion of the device is a safety feature to turn off compressor in case of refrigeration loss. The low pressure control is factory set to cut in (turn compressor on) at 40 PSIG and cut out (turn compressor off) at 10 PSIG.

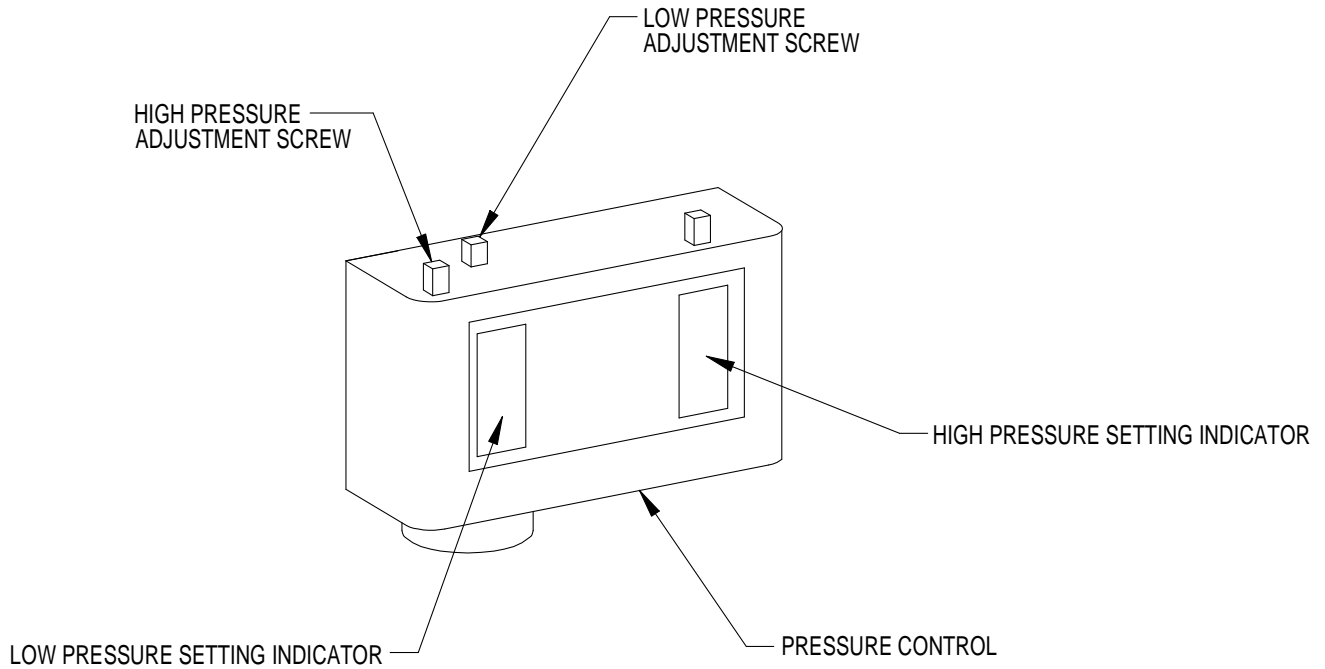

The high pressure control portion of this device is factory set at 385 PSIG. This is a safety device and is not adjustable.

## **Shelves**

The RSSL has 14" solid metal shelves as standard. These shelves are installed at the factory.

The shelves are adjustable in 1-5/8" increments. To adjust the shelves, first remove the shelf from the shelf brackets. Remove the shelf bracket from the shelf standard and reposition as desired. If optional shelf lights are installed, it will be necessary to unplug the shelf light cord before repositioning the shelf brackets.

The shelves can be installed horizontally or slanted at a 10° downward angle. To change the shelf slant, first remove the shelf from the shelf support. Lift the shelf supports up at the back until the brackets can be repositioned in the shelf standard slots. See diagram below

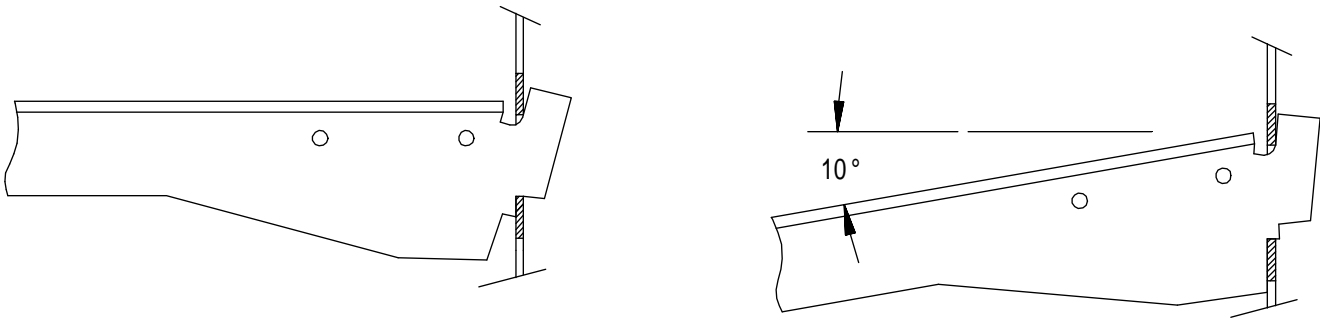

### **CAUTION:**



**Do not place more than 100 lbs. of product on a RSSL3 or RSSL4 Shelf.**

**Do not place more than 80 lbs. of product on a RSSL5 or RSSL6 Shelf.**

**Damage to the Shelf Standard may occur if the Shelf is overloaded.**

## **Periodic Maintenance**

### *Cleaning Condenser Coil*

Disconnect power to the unit.

Remove the front grill and vacuum the front surface of the condenser coil. This should be done every two weeks.

### *Cleaning Case Interior*

Refer to the Cleaning Instructions Section page XX

---

---

# CONTROL OPERATION

---

---

## Electronic Control

This unit is equipped with an Invensys – Ranco model E72R temperature control. The control parameters are set at the factory and cannot be manually changed in the field. Control parameter changes can only be made by downloading a new set of parameters using a program chip supplied by Federal Industries. The pre set control parameters are listed on the chart in the Settings Chart below.

## **Operation**

The control uses two sensors, one located in the air stream and one located on the evaporator coil. The sensor located in the air stream is referred to as the temperature control sensor. The sensor located on the evaporator coil is referred to as the coil sensor.

The temperature control sensor is located inside the top air duct behind the honeycomb material and is labeled (TEMP). The sensor location is critical for proper operation on the unit. Do not move or relocate this sensor.

The coil sensor is strapped to the evaporator coil and is labeled (DEFROST). This sensor location is critical for proper operation of the unit. Do not move or relocate this sensor.

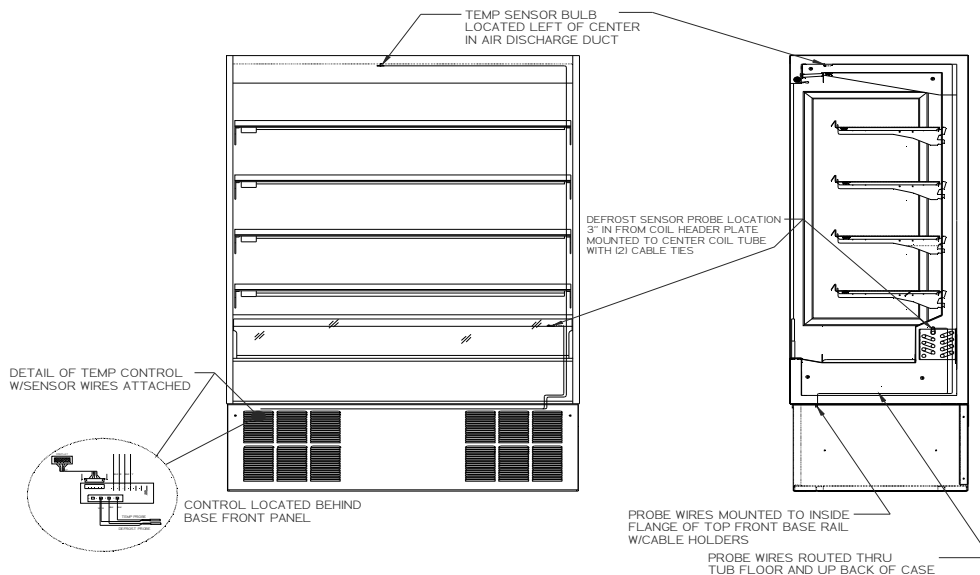

The temperature control is set to cut in at 41 degrees F. The Temp control cuts out at 13 degrees F at the coldest setting 'COLD' and 28 degrees F at the warmest setting, '1' on the control dial.

The temp control turns off the refrigeration system when the control is turned all the way counterclockwise to the (WARM) position.



## Defrost Cycle

The Ranco control is programmed to initiate defrost by two different methods. There are three programmed defrost cycles in the control which will initiate a defrost cycle every 8 hours. The unit does not have a time clock so the defrost cycles cannot be set for any specific time of day. The Ranco controller uses time to initiate the defrost cycle, and temperature to terminate the defrost cycle. The controller also has an 'On demand' defrost feature that will initiate a defrost cycle when the temperature differential between the evaporator temperature and the air temperature is more than 15 degrees for 5 minutes after 30 minutes into the refrigeration cycle.

## Control Factory Settings

The control parameters are set at the factory and cannot be manually changed in the field. Control parameter changes can only be made by downloading a new set of parameters using a program chip supplied by Federal Industries

TAB	PARAMETER DESCRIPTION	RSSL
<b>CONFIGURATION</b>	Controller Operation Temperature Units	Degrees Fahrenheit
	Defrost Termination Method	Evaporator Sensor
<b>SET-POINTS</b>	Cut-In Warm	40°F
	Cut-Out Warm	<b>34°F</b>
	Cut-In Cold	40°F
	Cut-Out Cold	<b>24°F</b>
<b>COMPRESSOR</b>	Compressor Minimum On Time	<b>5 minutes</b>
	Compressor Maximum On Time	<b>60 minutes</b>
<b>DISPLAY</b>	Defrost Display Lock (display indication during defrost)	SHOW CURRENT TEMPERATURE
<b>DEFROST</b>	Defrost Termination Temperature	45°F
	Time to First Defrost (hh:mm)	8 hr
	Time to subsequent Defrost	8 hr
	Defrost Max Duration	30 minutes

## **Control Display**

The control display is located in the unit base. It is programmed to display the current temperature from the control sensor located inside the air duct at the top of the case.

## **Minimum Run Timer Feature**

The unit controller is programmed to have the condensing unit run a minimum of 5 minutes, regardless of the control temp being satisfied. If the temperature control reaches the cut out set point before 5 minutes, the minimum run time setting in the control will keep the unit in a run cycle mode until the timer reaches 5 minutes. The refrigeration cycle will be off until the temperature control cut in temperature is reached.

This timer typically comes into effect in low ambient conditions where the unit may cycle too frequently to maintain proper product temperature.

## **Maximum Run Timer Feature**

The unit controller is programmed to have the condensing unit run a maximum of 60 minutes. If the unit has not reached cut out temperature setting in 60 minutes, the unit goes into on off cycle. This typically comes into effect in high ambient temperature and relative humidity conditions.

---

---

# **REFRIGERATION OPERATION**

---

---

## **Self Contained Models**

Refrigeration R404 Charge	<b>See Refrigeration And Electrical Data Pages</b>

The self-contained models are shipped from the factory with a completely operational 404A refrigeration system and require no modifications or adjustments upon installation. Case must be installed as per the installation section of this manual to provide proper condensing air cooling.

### **Self Contained Refrigeration Operation**

The unit temperature is controlled by the Electronic control outlined in the control section of this manual.

Note: The condenser fan is factory wired to run continuously.

# REFRIGERATION OPERATION

**Remote Models** Use pressure gauges to set pressure control.

Refrigeration R404 Charge	CHARGED IN FIELD
Remote Low Press. Switch Cut In	50 psi
Remote Low Press. Switch Cut Out	15 psi
Adjustable Head Master	200 psi
Remote High Press. Switch Cut Out	400 psi

The remote models are designed to use 404A refrigerant and shipped from the factory with the evaporator coil, expansion valve, and refrigerant solenoid valve. Filter Drier must be installed in the field. The electronic control runs identical to the Self Contained models except the electronic control opens and closes a refrigeration solenoid valve located on the liquid line instead of turning on and off a compressor. The solenoid valve closes and shuts off the refrigeration flow to the unit and initiates a pump down cycle. This will allow the remote low pressure switch at the condensing unit to open and shut off the remote compressor.

The condensing unit and pressure controls may be supplied from the factory for remote location installation. The condensing unit must be mounted and wired by the installer. The high low pressure switch must be wired in series with the compressor power supply as shown in wiring diagram below.

1. Mount condensing unit as close to the remote display case as practical. The refrigeration line should be as short as possible and should not exceed 100 feet.
2. Refrigeration parts between condensing unit and case are typically supplied by installing contractor.
3. Route properly sized and designed refrigeration lines from the condensing unit to the cabinet. Horizontal suction lines should be pitched downward towards the condensing unit at least 1/2" per 10' run to aid the oil drainage. A "P" trap must be installed in the suction line at the foot of every riser to insure oil return. Dry nitrogen should be used through tubing while brazing refrigeration lines.
4. Suction line must be insulated the entire length with Armaflex (or equivalent). Do not run liquid line inside insulation with suction line.
5. If remote control is not supplied by Federal Industries, the remote high/low-pressure control must be mounted, wired and pressures set by the installer.
6. Leak check condensing unit, cabinet, and all connecting tubing. Cabinet and condensing unit tubing should be checked to insure no leaks occurred during shipping or from rough handling. Make certain all refrigeration valves are opened and evacuate system to 500 microns. Charge the system with refrigerant type specified on the data plates.

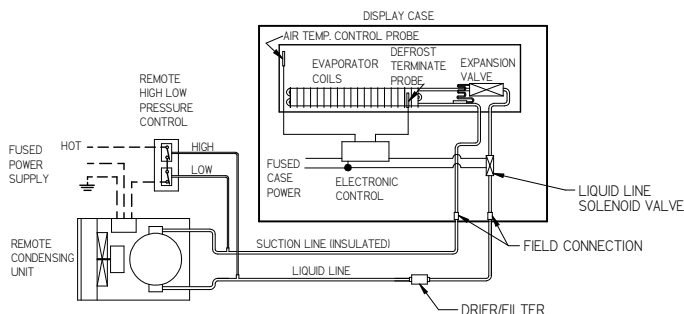

---

---

# CLEANING INSTRUCTIONS

---

---

## Acrylic Air Deflector Cleaning



**NOTICE:** Clear acrylic air deflector requires special washing procedures to prevent hazing and yellowing of material.

**NEVER USE** paper towels (wet or dry) for cleaning or drying and never use a dry towel.

**NEVER USE** glass cleaner of any kind.

Lightly dust (not wipe) surface with a damp Micro Fiber towel or chamois. The surface can then be washed using a small amount of dishwashing detergent such as Dawn or Joy and lukewarm water. Use a Micro Fiber towel or chamois, applying only light pressure. The cloth or chamois must be kept free of grit by frequently rinsing. Rinse surface with clear water and dry by blotting with a damp Micro Fiber towel or chamois.

### Daily Cleaning

The case should be cleaned thoroughly, as described in the weekly cleaning section, before it is used for the first time.



**NOTICE:** Avoid splashing or soaking any electrical components with water to prevent electrical damage to the case.



**NOTICE:** Shut off lights and power switches and remove all products from case. Allow sufficient time for the unit to reach room temperature before proceeding with cleaning.



**NOTICE:** Remove all products from the case before proceeding with cleaning procedure.



**NOTICE:** Acrylic air deflector requires special washing procedures to prevent hazing and yellowing of material. Clean as described in “Acrylic Air Deflector Cleaning” section of this manual.

**Note:** For major spills or foreign material buildup use complete weekly cleaning instructions.

**Note:** Detergents are not recommended and do not use abrasive cleaners or pads to prevent scratching of surfaces.

1. Dip rag in warm soapy water and ring out thoroughly. Wipe complete interior of case and dry with soft dry towel.
2. The remaining exterior surface should be wiped down using any ammoniated cleaners or soapy warm water and dried with soft dry towel..
3. **IMPORTANT:** Cleaning the clear acrylic plastic front air deflector requires special care to prevent hazing and yellowing of material. Clean as described in “Acrylic Air Deflector Cleaning” section of this manual.

## Weekly Cleaning



**NOTICE:** Avoid splashing or soaking any electrical components with water to prevent electrical damage to the case.



**NOTICE:** Shut off lights and power switches and remove all products from case. Allow sufficient time for the unit to reach room temperature before proceeding with cleaning.



**NOTICE:** Remove all products from case before proceeding with cleaning procedure.



**NOTICE:** Acrylic front air deflector requires special washing procedures to prevent hazing and yellowing of material.

**Note: Detergents are not recommended and do not use abrasive cleaners or pads to prevent scratching of surfaces.**

1. Remove interior shelving from unit as described in the “Shelving Installation and Removal” section of this manual.
2. Dip rag in warm soapy water and ring out thoroughly. Clean all shelves and shelf brackets and dry with soft dry towel.
3. Remove tower side panels by lifting (4) latch levers and pulling tower side panel out away from tower.
4. Remove the tower inner panel by lifting panel up until retaining pins clear key slots hole. Pull panel out of tower.
5. Dip rag in warm soapy water and ring out thoroughly. Clean the tower side panels, tower inner panels and inside both tower ends. Dry with soft dry towel
6. Lift the display decks up and out of evaporator tub.
7. Remove the fan shroud assembly by removing (4) retaining screws from the outer flange and the (2) from the inner flange. Lift the fan shroud assembly and reach in and unplug the evaporator fan motor cord(s). Lift fan shroud assembly out of tub.
8. Clean the display deck(s) using warm soapy water and a brush. Rinse thoroughly and allow dry. Wipe off fan shroud assembly (do not rinse or submerge fan motors).
9. Clean the entire interior of the case using warm soapy water. Wipe off all soapy water with a damp cloth and allow to dry. (DO NOT use solvents such as Acetone, Benzene, Carbon Tetrachloride, and Lacquer Thinners)
- 10. IMPORTANT: Cleaning the clear acrylic plastic front air deflector requires special care to prevent hazing and yellowing of material. Clean as described in “Acrylic Air Deflector Cleaning” section of this manual.**
11. Reassemble all components in reverse order.

NOTE: Depending on the amount of usage and spillage of foreign material, some fasteners may have to be removed and parts disassembled to allow proper cleaning of the unit.

---

---

# SERVICE INFORMATION

---

---

**CAUTION**  
RISK OF ELECTRIC SHOCK

DISCONNECT POWER  
BEFORE SERVICING UNIT

Before any service work is performed on the case, make sure all power is disconnected to the case.

Service problems or request for repair parts from authorized service agencies, trained service personnel, or owners should be referred to:

**CUSTOMER SERVICE DEPARTMENT**  
Federal Industries  
P.O. Box 290  
Belleville, WI 53508  
Toll Free: (800) 356-4206 / WI Phone (608) 424-3331  
Fax: (608) 424-3234

.....

## **Pre-Service Checklist**

You may avoid the cost and inconvenience of an unnecessary service call by first reviewing this checklist of frequently encountered situations that can cause unsatisfactory case performance.



**CAUTION:** Before servicing case turn off power at the main breaker of fuse box.

### ***Case Does Not Operate***

- Check for disconnected power supply.
- Check for tripped breaker or blown fuse.

## **Pre-Service Checklist**

### **Case Temperature Too Warm**

Check that top air discharge grill and/or bottom air intake grill are not blocked.

Check for a blocked or dirty condenser coil.

Check that there are no outside air disturbances in or around cases. These disturbances can be caused by nearby doors or entrances, overhead ceiling fans or air diffuser vents, direct sunlight, or other heat sources. The location of open refrigerated merchandisers is critical to case performance.

Make sure that warm product is not being installed inside the case. All product must be pre-chilled prior to loading for proper case performance.

Check temperature/pressure control for proper settings.

Check cold air flow. Lack of or no air flow may indicate a blocked evaporator coil or defective evaporator fan motor. Contact a qualified service company if there is no air flow inside case.

### **Lights Do Not Operate**

Check that light switch located in top light housing is "on".

Check that all optional shelf light cords are securely plugged into sockets in back panel.

Check that all light bulbs are properly seated in the light holders.

### **Overflow of Condensate Evaporator**

Check that drain line is properly located over the water reservoir.

Check that store conditions do not exceed 75° and/or 55% relative humidity for prolonged periods of time.

Check that condensate pan heaters are operating. Exterior base of condensate pan should be evenly warm on both long sides of pan.

### **Special Service Situations**

There are rare occasions when the refrigerant charge must be evacuated from a case in order to perform service work. In those situations, Federal Industries recommends that the refrigerant charge be evacuated into a recovery system to prevent the possibility of hydrofluorocarbons (HFC's) from being released into the atmosphere. The release of HFC's into the atmosphere is a source of greenhouse gases.

If moisture or liquid is observed around or under a Federal Industries case, an immediate investigation should be made by qualified personnel to determine the source of the moisture or liquid. The investigation made should determine if the case is malfunctioning or if there is a simple housekeeping problem.

Moisture or liquid around or under a case is a potential slip/fall hazard for persons walking by or working in the general area of the case. Any case malfunction or housekeeping problem that creates a slip/fall hazard around or under a case should be corrected immediately.

---

## **SALE & DISPOSAL**

---

### **Owner Responsibility**

If you sell or give away your Federal Industries case, you must make sure that all safety labels and the Installation-Service Manual are included with it. If you need replacement labels or manuals, Federal Industries will provide them free of charge. Contact the Customer Service Department at Federal Industries at (800) 356-4206.

The Customer Service Department at Federal Industries should be contacted at the time of sale or disposal of your case so records may be kept of its new location.

If you sell or give away your Federal Industries case and you evacuate the refrigerant charge before shipment, Federal Industries recommends that the charge be evacuated into a recovery system to reduce the possibility of HFC's from being released into the atmosphere. The release of HFC's into the atmosphere is a source of greenhouse gases.



# REFRIGERATION AND ELECTRICAL DATA

Model	RSSL378SC		RSSL378R		RSSL378SC	
<b>POWER SUPPLY, VOLTS</b>	120Volts		120Volts		208-240Volts	
Frequency	60 Hertz		60 Hertz		60 Hertz	
Phase	1 Phase		1 Phase		1 Phase	
Number of Wires	2		2		2	
Refrigerant Charge (R-404A)	3 lbs.		----		3 lbs.	
	<b>AMPS VOLTS</b>		<b>AMPS VOLTS</b>		<b>AMPS VOLTS</b>	
Compressor						
RLA	9.2	120	----	----	4.3	208-240
LRA	58.8	120	----	----	31.0	208-240
Condenser Fan Motor	2.0	120	----	----	0.6	208-240
Evaporator Fan Motor	0.4	120	0.4	120	0.7	208-240
Lights (Includes Optional Shelf Lights)	1.0	120	1.0	120	0.5	208-240
Condensate Pan Heater	5.0	120	10	120	5.0	208-240
Condensate Pump	1.0	120	1.0	120	0.5	208-240

Refer to the rating plate data attached to the rear of the case for Maximum Fuse Size and Minimum Circuit Ampacity.

# REFRIGERATION AND ELECTRICAL DATA

<b>Model</b>	<b>RSSL478SC</b>		<b>RSSL478-R</b>		<b>RSSL478SC</b>	
<b>POWER SUPPLY, VOLTS</b>	120Volts		120 Volts		208-240 Volts	
Frequency	60 Hertz		60 Hertz		60 Hertz	
Phase	1 Phase		1 Phase		1 Phase	
Number of Wires	2		2		2	
Refrigerant Charge (R-404A)	4 lbs.		----		4 lbs	
	<b>AMPS</b>	<b>VOLTS</b>	<b>AMPS</b>	<b>VOLTS</b>	<b>AMPS</b>	<b>VOLTS</b>
Compressor						
RLA	12.1	120	----	----	5.7	208-240
LRA	68.0	120	----	----	31.0	208-240
Condenser Fan Motor	2.0	120	----	----	0.7	208-240
Evaporator Fan Motor (2)	0.4ea	120	0.4ea	120	0.2ea.	208-240
Lights (includes optional Shelf lights)	1.2	120	1.2	120	1.2	208-240
Condensate Pan Heater	5.0	120	10	120	5.0	208-240
Condensate Pump	1.0	120	1.0	120	0.5	208-240

Refer to the rating plate data attached to the rear of the case for Maximum Fuse Size and Minimum Circuit Ampacity.

---



---

# REFRIGERATION AND ELECTRICAL DATA

---



---

<b>Model</b>	<b>RSSL578SC</b>		<b>RSSL578R</b>	
<b>POWER SUPPLY, VOLTS</b>	208-240 Volts		120 Volts	
Frequency	60 Hertz		60 Hertz	
Phase	1 Phase		1 Phase	
Number of Wires	3		2	
Refrigerant Charge (R-404A)	4.25 lbs.		----	
	<b>AMPS</b>	<b>VOLTS</b>	<b>AMPS</b>	<b>VOLTS</b>
Compressor				
RLA	7.7	208-240	----	----
LRA	54.0	208-240	----	----
Condenser Fan Motor	0.7	208-240	----	----
Evaporator Fan Motor (2)	0.2ea	208-240	0.4ea	120
Lights (includes optional Shelf lights)	2.0	208-240	2.0	120
Condensate Pan Heater	5.0	208-240	10	120
Condensate Pump	0.5	208-240	1.0	120

Refer to the rating plate data attached to the rear of the case for Maximum Fuse Size and Minimum Circuit Ampacity.

---



---

# REFRIGERATION AND ELECTRICAL DATA

---



---

<b>Model</b>	<b>RSSL678SC</b>	<b>RSSL678R</b>		
<b>POWER SUPPLY, VOLTS</b>	208-240 Volts	120 Volts		
Frequency	60 Hertz	60 Hertz		
Phase	1 Phase	1 Phase		
Number of Wires	2	2		
Refrigerant Charge (R-404A)	4.25 lbs.	----		
	<b>AMPS</b>	<b>VOLTS</b>	<b>AMPS</b>	<b>VOLTS</b>
Compressor				
RLA	7.7	208-240	----	----
LRA	54.0	208-240	----	----
Condenser Fan Motor	0.7	208-240	----	----
Evaporator Fan Motor (3)	0.2ea	208-240	0.4ea	120
Lights (includes optional Shelf lights)	2.0	208-240	2.0	120
Condensate Pan Heater	5.0	208-240	10	120
Condensate Pump	0.5	208-240	1.0	120

Refer to the rating plate data attached to the rear of the case for Maximum Fuse Size and Minimum Circuit Ampacity.

# REPLACEMENT PARTS

## MODEL RSSL378

<b>Part Description</b>	<b>RSSL378SC</b>	<b>RSSL378R</b>	<b>RSSL378SC</b>
<b>Refrigeration System</b>	<b>Part # 120V</b>	<b>Part # 120V</b>	<b>208-240V</b>
Condensing Unit (Self-Contained Only)	30-17727	-----	30-20512
Compressor (Replacement)	30-18050	-----	30-18052
Evaporator Coil	33-13283	33-13283	33-13283
Expansion Valve	32-19419	32-19419	32-19419
Evaporator Fan Motor	41-11628	41-11628	41-15925
Evaporator Fan Blade	72-32507	72-32507	72-32507
Filter Drier	32-12626	-----	32-12626
Dual Pressure Control	32-51009	-----	32-51009
Solenoid Valve	-----	32-14325	-----
Coil Solenoid Valve	-----	41-14324	-----
<b>Electrical Components</b>			
Solid State Controller (RANCO)	32-19445-1	32-19445-1	32-19445-1
Solid State Digital Display (RANCO)	32-19446	32-19446	32-19446
Ribbon Cable (RANCO)	32-19093	32-19093	32-19093
Three Meter Sensor Defrost (RANCO)	32-19094	32-19094	32-19094
Five Meter Sensor Temp. (RANCO)	32-19209	32-19209	32-19209
Temperature Control (CAREL)	32-19864-1	32-19864-1	32-19865-1
Control Probes (CAREL)	32-19866	32-19866	32-19866
Condensate PTC Heater	40-19331	40-19331	40-19392
Light Led	42-19038-5	42-19038-5	42-19038-5
Power Supply Led	39-19039	39-19039	39-19039
Light Bulb Fluorescent	42-11519	42-11519	42-11519
Ballast Two Lamps	39-12902	39-12902	39-12902
Ballast Four Lamps	39-12904	39-12904	39-12904
Lamp holder – Spring-Loaded (Shelf Light)	42-10833	42-10833	42-10833
Lamp holder – Stationery (Shelf Light)	42-10834	42-10834	42-10834
Light Switch (On/Off)	41-11066	41-11066	41-11066
Tombstone Socket (Top Light)	42-19125	42-19125	42-19125
Cap. Tombstone Socket	42-15441	42-15441	42-15441
Lamp Shield	42-15638	42-15638	42-15638
Heater Wire Assembly	43-14892	43-14892	43-19467
Condensate Pan	SA5406-1	SA5406-1	SA5406-2
Condensate Pump	47-15686	47-15686	47-15687
Cord & Plug	43-30818	-----	43-19090
<b>Miscellaneous Components</b>			
Price Tag Molding	W11329-21	W11329-21	W11329-21
Shelf Bracket, Left Side	M19850-L	M19850-L	M19850-L
Shelf Bracket, Right Side	M19850-R	M19850-R	M19850-R
Shelf 14"	M19851-1	M19851-1	M19851-1
Thermometer	32-13662	32-13662	32-13662
Air Deflector	15-19336-3	15-19336-3	15-19336-3
<b>Optional Parts</b>			
White Shelf Lamp Cord	43-19079-A	43-19079-A	43-19079-A
White Shelf Lamp Socket/Receptacle	43-19080-A	43-19080-A	43-19080-A
Black Shelf Lamp Cord	43-19079-B	43-19079-B	43-19079-B
Black Shelf Lamp Socket/Receptacle	43-19080-B	43-19080-B	43-19080-B
Black Shelf Lamp Cord Led	43-19061	43-19061	43-19061
Energy Savings Night Curtain	65-19300	65-19300	65-19300
Security Night Cover	701-918	701-918	701-918

# REPLACEMENT PARTS

## MODEL RSSL478

<b>Part Description</b>	<b>RSSL478SC</b>	<b>RSSL478R</b>	<b>RSSL478SC</b>
<b>Refrigeration System</b>	<b>Part # 120V</b>	<b>Part # 120V</b>	<b>208-240V</b>
Condensing Unit (Self-Contained Only)	30-17728	-----	30-17888
Compressor (Replacement)	30-18051	-----	30-18052
Evaporator Coil	33-11541	33-11541	33-11541
Expansion Valve	32-19419	32-19419	32-19419
Evaporator Fan Motor	41-11628	41-11628	41-15925
Evaporator Fan Blade	72-13316	72-13316	72-13316
Filter Drier	32-12626	-----	32-12626
Dual Pressure Control	32-51009	-----	32-51009
Solenoid Valve	-----	32-14325	-----
Coil Solenoid Valve	-----	41-14324	-----
<b>Electrical Components</b>			
Solid State Controller (RANCO)	32-19445-1	32-19445-1	32-19445-1
Solid State Digital Display (RANCO)	32-19446	32-19446	32-19446
Ribbon Cable (RANCO)	32-19093	32-19093	32-19093
Three Meter Sensor Defrost (RANCO)	32-19094	32-19094	32-19094
Five Meter Sensor Temp. (RANCO)	32-19209	32-19209	32-19209
Temperature Control (CAREL)	32-19864-1	32-19864-1	32-19865-1
Control Probes (CAREL)	32-19866	32-19866	32-19866
Condensate PTC Heater	40-19331	40-19331	40-19392
Light Led	42-19038	42-19038	42-19038
Power Supply Led	39-19039	39-19039	39-19039
Light Bulb Fluorescent	42-11069	42-11069	42-11069
Ballast Two Lamps	39-12902	39-12902	39-12902
Ballast Four Lamps	39-12904	39-12904	39-12904
Lamp holder – Spring-Loaded (Shelf Light)	42-10833	42-10833	42-10833
Lamp holder – Stationery (Shelf Light)	42-10834	42-10834	42-10834
Light Switch (On/Off)	41-11066	41-11066	41-11066
Tombstone Socket (Top Light)	42-19125	42-19125	42-19125
Cap. Tombstone Socket	42-15441	42-15441	42-15441
Lamp Shield	42-15503	42-15503	42-15503
Heater Wire Assembly	43-14891	43-14891	43-15926
Condensate Pan	SA5406-1	SA5406-1	SA5406-2
Condensate Pump	47-15686	47-15686	47-15687
Cord & Plug	43-30818	-----	43-19090
<b>Miscellaneous Components</b>			
Price Tag Molding	W11329-22	W11329-22	W11329-22
Shelf Bracket, Left Side	M19850-L	M19850-L	M19850-L
Shelf Bracket, Right Side	M19850-R	M19850-R	M19850-R
Shelf 14"	M19851-2	M19851-2	M19851-2
Thermometer	32-13662	32-13662	32-13662
Air Deflector	15-19336-6	15-19336-6	15-19336-6
<b>Optional Parts</b>			
White Shelf Lamp Cord	43-19079-A	43-19079-A	43-19079-A
White Shelf Lamp Socket/Receptacle	43-19080-A	43-19080-A	43-19080-A
Black Shelf Lamp Cord	43-19079-B	43-19079-B	43-19079-B
Black Shelf Lamp Socket/Receptacle	43-19080-B	43-19080-B	43-19080-B
Black Shelf Lamp Cord Led	43-19061	43-19061	43-19061
Energy Savings Night Curtain	65-19460	65-19460	65-19460
Security Night Cover	703-918	703-918	703-918

---

---

# REPLACEMENT PARTS

## MODEL RSSL578

---

---

<b>Part Description</b>	<b>RSSL578SC</b>	<b>RSSL578R</b>
<b><u>Refrigeration System</u></b>		
Condensing Unit (Self-Contained Only)	30-17889	-----
Compressor (Replacement)	30-18054	-----
Evaporator Coil	33-18024	33-18024
Expansion Valve	32-19416	32-19416
Evaporator Fan Motor	41-15925	41-11628
Evaporator Fan Blade	72-32507	72-32507
Filter Drier	32-12626	-----
Dual Pressure Control	32-51009	-----
Solenoid Valve	-----	32-14325
Coil Solenoid Valve	-----	41-14324
<b><u>Electrical Components</u></b>		
Solid State Controller (RANCO)	32-19445-1	32-19445-1
Solid State Digital Display (RANCO)	32-19446	32-19446
Ribbon Cable (RANCO)	32-19093	32-19093
Three Meter Sensor Defrost (RANCO)	32-19094	32-19094
Five Meter Sensor Temp. (RANCO)	32-19209	32-19209
Temperature Control (CAREL)	32-19865-1	32-19864-1
Control Probes (CAREL)	32-19866	32-19866
Condensate PTC Heater	40-19392	40-19331
Light Led	42-19038-6	42-19038-6
Power Supply Led	39-19039	39-19039
Light Bulb Fluorescent	42-11070	42-11070
Ballast Two Lamps	39-12902	39-12902
Ballast Three Lamps	39-12903	39-12903
Ballast Four Lamps	39-12904	39-12904
Lamp holder – Spring-Loaded (Shelf Light)	42-10833	42-10833
Lamp holder – Stationery (Shelf Light)	42-10834	42-10834
Light Switch (On/Off)	41-11066	41-11066
Tombstone Socket (Top Light)	42-19125	42-19125
Cap. Tombstone Socket	42-15441	42-15441
Lamp Shield	42-15640	42-15640
Heater Wire Assembly	43-20356	43-18043
Condensate Pan	SA5406-2	SA5406-12
Condensate Pump	47-15687	47-15686
Cord & Plug	43-19090	-----
<b><u>Miscellaneous Components</u></b>		
Price Tag Molding	W11329-23	W11329-23
Shelf Bracket, Left Side	M19850-L	M19850-L
Shelf Bracket, Right Side	M19850-R	M19850-R
Shelf 14"	M19851-3	M19851-3
Thermometer	32-13662	32-13662
Air Deflector	15-19336-9	15-19336-9
<b><u>Optional Parts</u></b>		
White Shelf Lamp Cord	43-19079-A	43-19079-A
White Shelf Lamp Socket/Receptacle	43-19080-A	43-19080-A
Black Shelf Lamp Cord	43-19079-B	43-19079-B
Black Shelf Lamp Socket/Receptacle	43-19080-B	43-19080-B
Black Shelf Lamp Cord	43-19061	43-19061
Energy Saving Night Curtain	65-19458	65-19458
Security Night Cover	453-901	454-901

# REPLACEMENT PARTS

## MODEL RSSL678

Part Description	RSSL678SC	RSSL678R
<b><u>Refrigeration System</u></b>		
Condensing Unit (Self-Contained Only)	30-17889	-----
Compressor (Replacement)	30-18054	-----
Evaporator Coil	33-11542	33-11542
Expansion Valve	32-19416	32-19416
Evaporator Fan Motor	41-15925	41-11628
Evaporator Fan Blade	72-13316	72-13316
Filter Drier	32-12626	-----
Dual Pressure Control	32-51009	-----
Solenoid Valve	-----	32-14325
Coil Solenoid Valve	-----	41-14324
<b><u>Electrical Components</u></b>		
Solid State Controllor (RANCO)	32-19445-1	32-19445-1
Solid State Digital Display (RANCO)	32-19446	32-19446
Ribbon Cable (RANCO)	32-19093	32-19093
Three Meter Sensor Defrost (RANCO)	32-19094	32-19094
Five Meter Sensor Temp. (RANCO)	32-19209	32-19209
Temperature Control (CAREL)	32-19865-1	32-19864-1
Control Probes (CAREL)	32-19866	32-19866
Condensate PTC Heater	40-19392	40-19331
Light Led	42-19038-5	42-19038-5
Power Supply Led	39-19039	39-19039
Light Bulb Fluorescent	42-11071	42-11071
Ballast Two Lamps	39-12902	39-12902
Ballast Three Lamps	39-12903	39-12903
Ballast Four Lamps	39-12904	39-12904
Lamp holder – Spring-Loaded (Shelf Light)	42-10833	42-10833
Lamp holder – Stationery (Shelf Light)	42-10834	42-10834
Light Switch (On/Off)	41-11066	41-11066
Tombstone Socket (Top Light)	42-19125	42-19125
Cap. Tombstone Socket	42-15441	42-15441
Lamp Shield	42-15642	42-15642
Heater Wire Assembly	43-19113	43-14893
Condensate Pan	SA5406-2	SA5406-12
Condensate Pan 1800W OPTIONAL	SA5406-3	SA5406-13
Condensate Pump	47-15687	47-15686
Cord & Plug	43-19090	-----
<b><u>Miscellaneous Components</u></b>		
Price Tag Molding	W11329-24	W11329-24
Shelf Bracket, Left Side	M19850-L	M19850-L
Shelf Bracket, Right Side	M19850-R	M19850-R
Shelf 14"	M19851-4	M19851-4
Thermometer	32-13662	32-13662
Air Deflector	15-19336-12	15-19336-12
<b><u>Optional Parts</u></b>		
White Shelf Lamp Cord	43-19079-A	43-19079-A
White Shelf Lamp Socket/Receptacle	43-19080-A	43-19080-A
Black Shelf Lamp Cord	43-19079-B	43-19079-B
Black Shelf Lamp Socket/Receptacle	43-19080-B	43-19080-B
Black Shelf Lamp Cord	43-19061	43-19061
Energy Saving Night Curtain	65-19300	65-19300
Security Night Cover	707-918	707-918



# RSSL DISPLAY AREA AND VOLUME

	RSSL378	RSSL478	RSSL578	RSSL678
CUBIC FT. PER SHELF	2.2	2.9	3.7	4.5
CUBIC FT. DISPLAY DECK	2.7	3.6	4.6	5.5
TOTAL CUBIC FT.	11.5	15.2	19.4	23.5
SQUARE INCHES PER SHELF	468.0	622.0	790.0	958.0
SQUARE INCHES DISPLAY DECK	418.0	555.0	705.0	855.0
TOTAL SQUARE INCHES	2290.0	3043.0	3865.0	4687.0
SHELF WIDTH " L "	33.44	44.44	56.44	68.44

NOTE: CUBIC FEET IS MEASURED WITH 2" CLEARANCE BETWEEN SHELVES

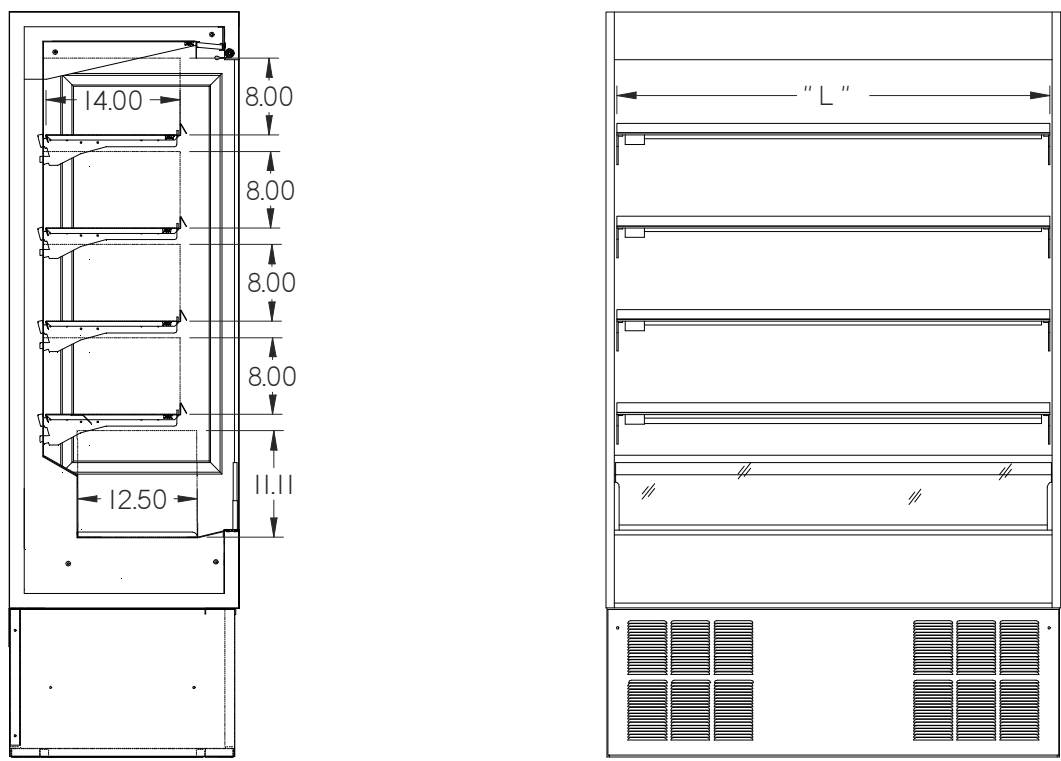

# WIRING DIAGRAM 120V - SELF CONTAINED

## RSSL378SC, RSSL478SC

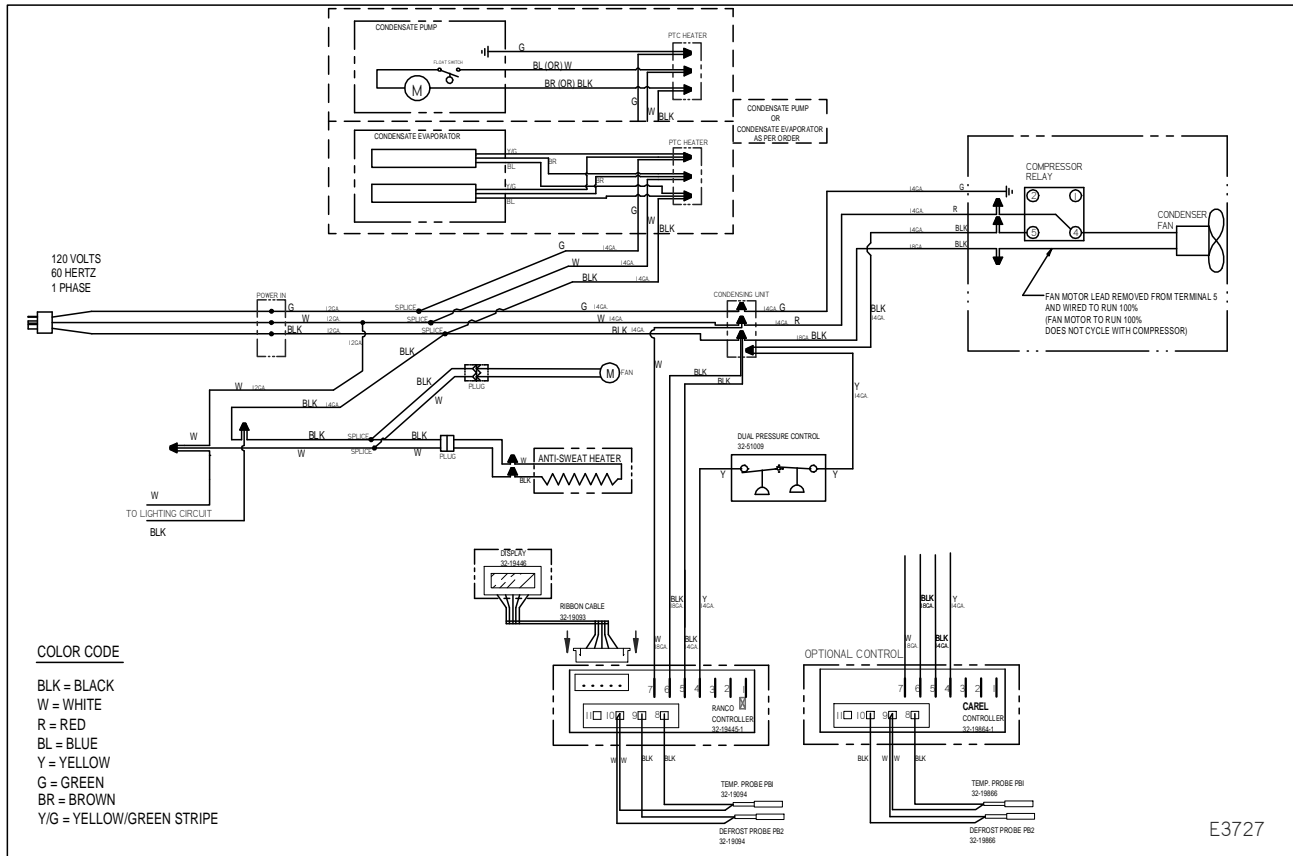

# WIRING DIAGRAM 208-240V - SELF CONTAINED RSSL378SC, RSSL478SC, RSSL578SC & RSSL678SC

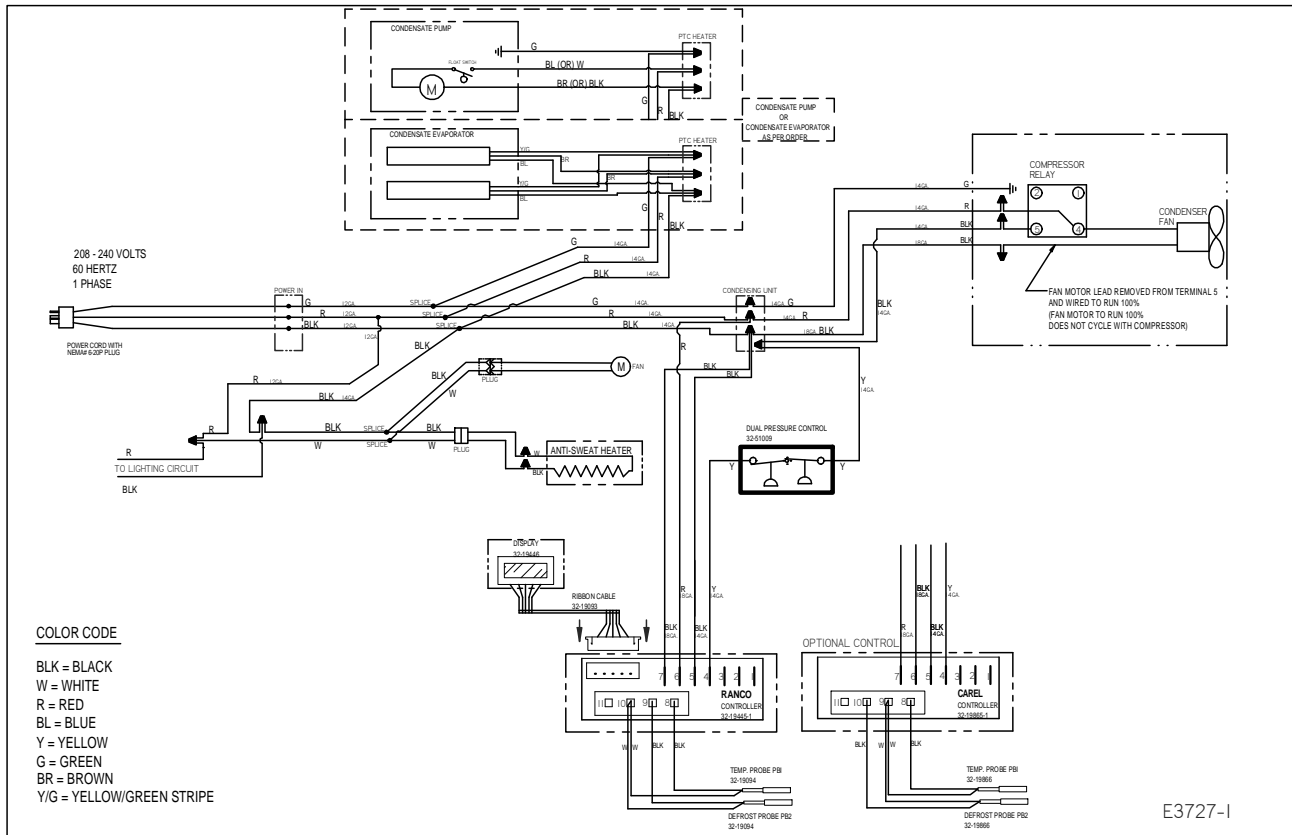

# WIRING DIAGRAM 120V - REMOTE

## RSSL378R, RSSL478R, RSSL578R, & RSSL678R

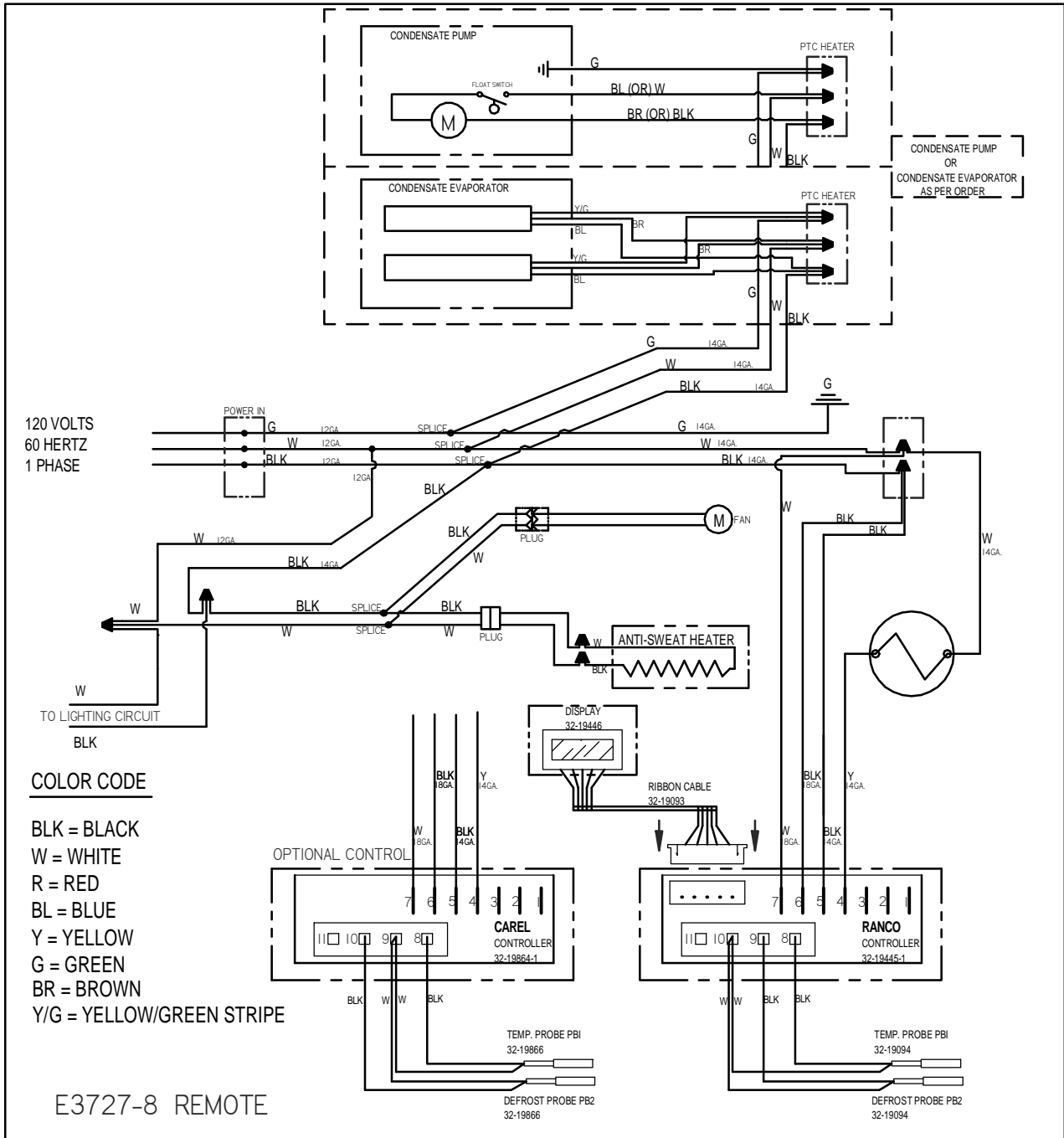

# WIRING DIAGRAM

## TOP LIGHTS & SHELF LIGHTS

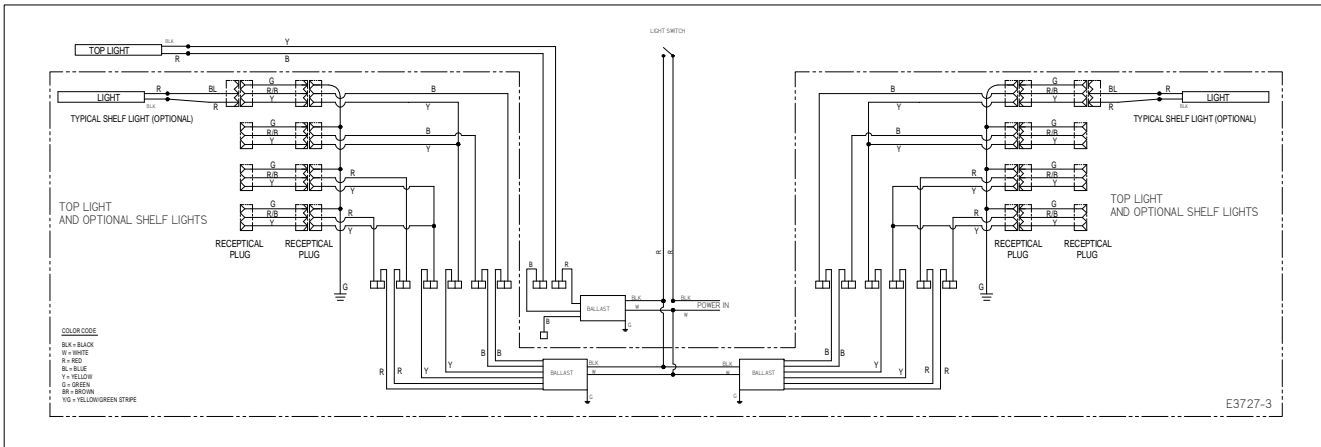
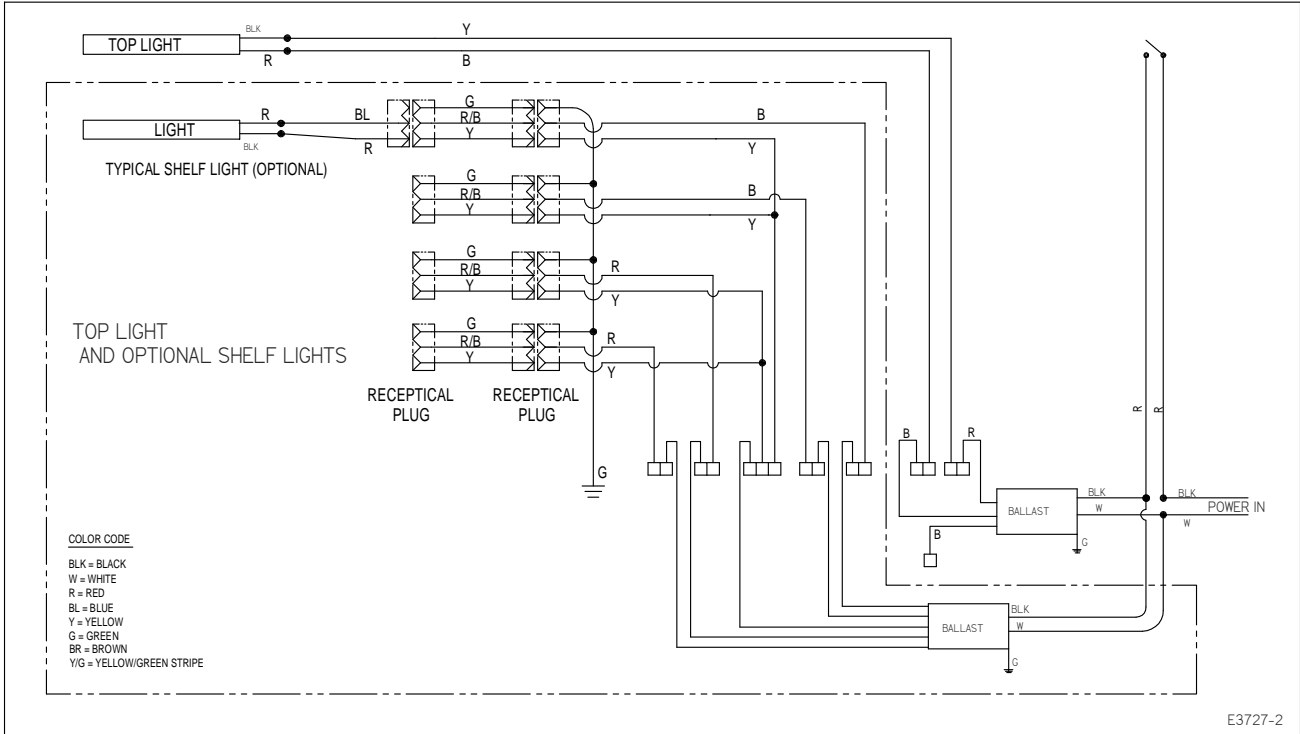

# WIRING DIAGRAM

## TOP LIGHTS LED

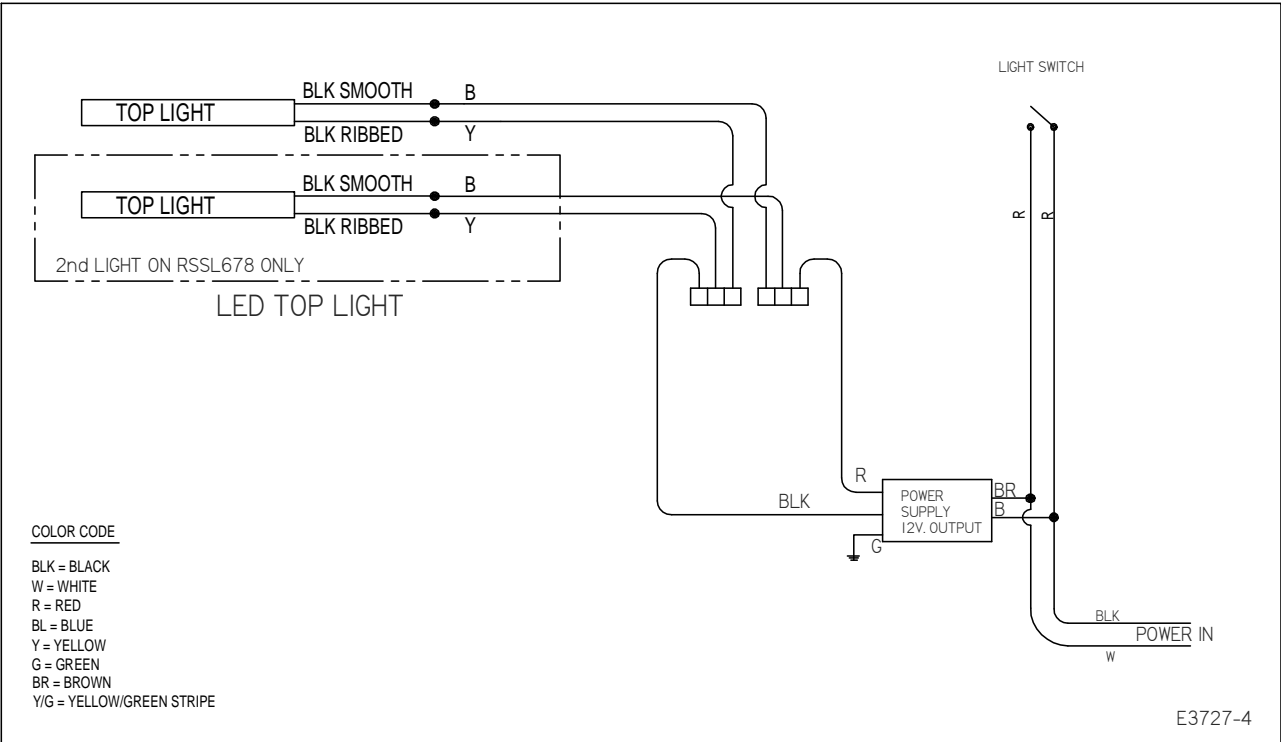

# WIRING DIAGRAM – OPTIONAL LIGHTING CIRCUIT TOP LIGHTS & SHELF LIGHTS LED

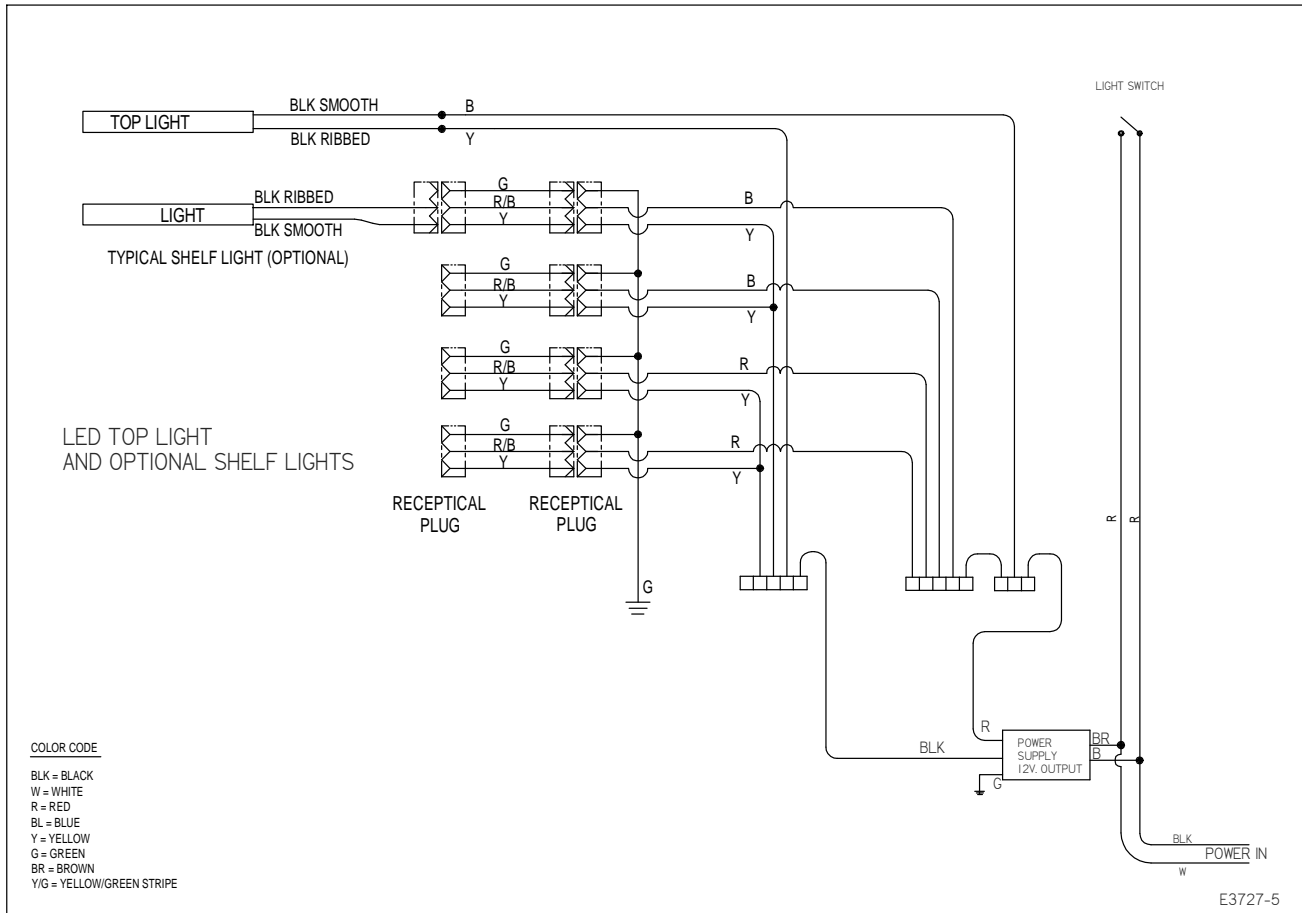

# WIRING DIAGRAM – OPTIONAL LIGHTING CIRCUIT TOP LIGHTS & SHELF LIGHTS LED

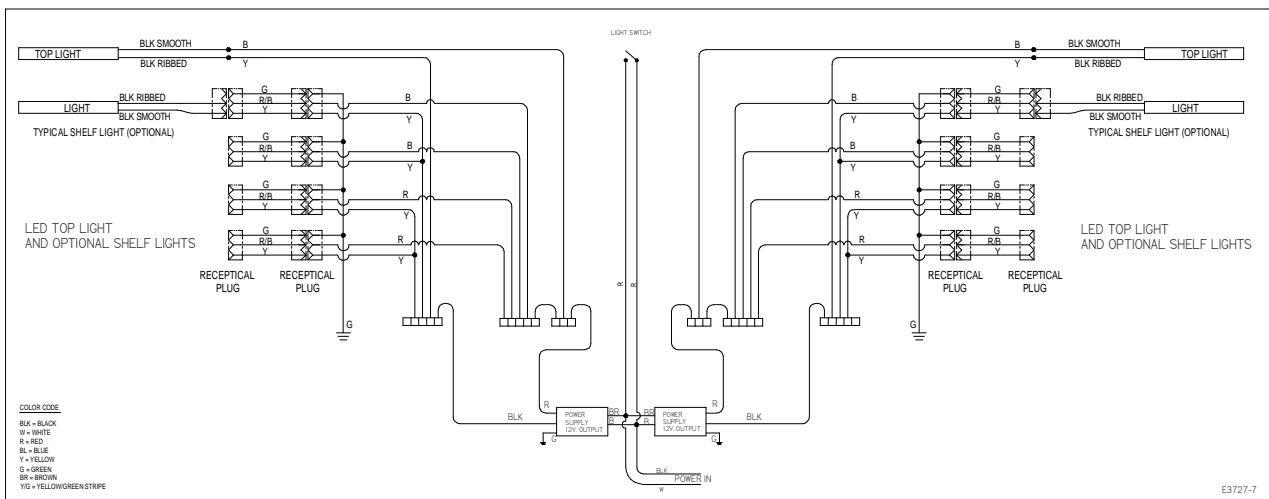
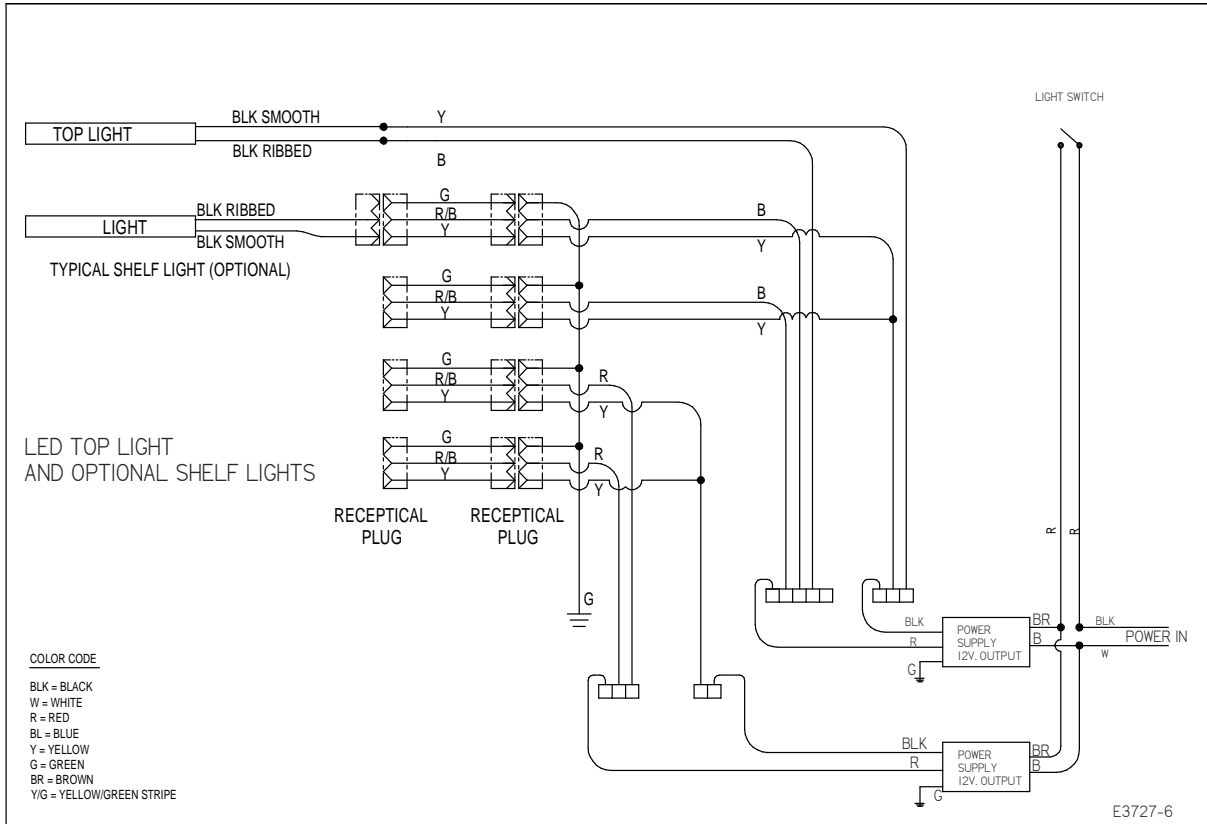



THIS PAGE INTENTIONALLY LEFT BLANK