CBS-6000 Series Coffee Brewers

Models:

- ▶ **CBS-61H**
- ▶ **CBS-62H**



Driven To Pioneer Innovation™

Table of Contents

Contact Information	2	Operating Procedures	7
Introduction	2	Service	8
Product Description/Features	2	Dispenser Parts	13
Specifications	2	Brewer Parts	14
Dimensions & Utility Connections	4	Troubleshooting	20
Installation	5		

FETCO® LUXUS® and Driven To Pioneer Innovation™ are trademarks or trade names of Food Equipment Technologies Company.

Contact Information

FETCO

Food Equipment Technologies Company
600 Rose Road
Lake Zurich • IL • 60047-0429 • USA

Internet: www.fetco.com

Phone: (800) 338-2699 (US & Canada)
(847) 719-3000

Fax: (847) 719-3001

Email: sales@fetco.com
techsupport@fetco.com

Introduction

This manual applies only to CBS-6000 Series brewers manufactured with solid state relays (SSR) in the heating circuit. Earlier versions utilized mercury relays for heating. Refer to User's Guide # P005 for mercury relay versions.

The first digit of the serial number can be used to identify the version of a particular unit:

Serial number begins with **6** – SSR version.

Serial number begins with **0** or **1** – mercury relay version.

Product Description/Features

CBS-61H - Single Coffee Brewing System

CBS-62H - Twin Coffee Brewing System

- 3 gallon, thermal, portable, all stainless steel dispensers
- Stainless steel, gourmet size brew baskets
- Brew basket double safety locks
- Open type, leak free dispense system
- Fully automatic, with electronic temperature control
- Two level tank drain system
- Total serviceability from the front

Optional Features:

- Half batch brewing capability
(Can be added at any time)
- Color stainless steel finish
- Export voltage

Specifications

Brew Volume:

Full Batch 3 gal. (11.4 lit.)
Half Batch 1.5 gal. (5.7 lit.)

Brew Time:

Full Batch 5 - 5.5 min.
Half Batch 2.5 - 2.75 min.

(Allow an extra 2-4 minutes for coffee to finish dripping)

Coffee Filter Size: 20" X 8" – Product # F004
18" X 7½" - optional half batch Product # F005

Temperature:

205°F inside water tank (at sea level)
195°F ± 5° at sprayhead

Bypass Range: 0 to 33%

(Factory set at 0% unless specified)

Water Requirements:

CBS-61H: 20-75 psig, 1 gpm
CBS-62H: 20-75 psig, 2 gpm

Weights and Capacities

Brewer Model	Weight (empty)	Water tank Capacity & Weight		Weight (filled)	Dispenser Weight, ea.	Dispenser Filled, ea.	Total Weight Brewer & Dispensers, Filled
CBS-61H	111 lbs.	8 gal.	66.4 lbs.	177 lbs.	18 lbs.	42.5 lbs.	220 lbs.
CBS-62H	195 lbs.	14 gal.	116.2 lbs.	311.2 lbs.	18 lbs.	42.5 lbs.	397 lbs.

Electrical Configuration and Brewing Efficiency

CBS-61H

Electrical Code	Heater Configuration	Voltage Connection	Phase	Wires	KW	Maximum Amp draw	Batches per Hour	
							Cold Water	Hot Water
C61016	2 X 3000 watt	120/208	single	3 + ground	4.6	22.0	3.7	8.6
		120/220	single	3 + ground	5.1	23.3	4.3	9.0
		120/240	single	3 + ground	6.1	25.4	5.0	9.0
C61026	2 X 4000 watt	120/208	single	3 + ground	6.1	29.3	5.0	9.0
		120/220	single	3 + ground	6.8	30.9	5.8	9.0
		120/240	single	3 + ground	8.1	33.8	6.6	9.0
C61036	3 X 3000 watt	120/208	three	4 + ground	7.0	19.4	5.6	9.0
		120/220	three	4 + ground	7.8	20.5	6.5	9.0
		120/240	three	4 + ground	9.1	22.4	7.4	9.0
C61046	3 X 4000 watt	120/208	three	4 + ground	9.2	25.6	7.4	9.0
		120/220	three	4 + ground	10.3	27.1	8.6	9.0
		120/240	three	4 + ground	12.1	29.6	9.0	9.0
C61146	3 X 4000 W	480	three	3 + ground	12.1	14.9	9.0	9.0

Steam Heated Version

Electrical Code	Maximum Steam Demand	Steam Pressure	Volts	Wires	Maximum Amp draw	Maximum Batches/Hour
C61986	40 lbs./hr.	10-15 PSI	120	2+ground	0.8	9.0

CBS-62H

Electrical Code	Heater Configuration	Voltage Connection	Phase	Wires	KW	Maximum Amp draw	Batches per Hour	
							Cold Water	Hot Water
C62016	3 X 3000 watt	120/208	single	3 + ground	6.1	32.9	5.6	12.9
		120/220	single	3 + ground	7.7	34.8	6.5	14.9
		120/240	single	3 + ground	9.1	37.9	7.4	17.2
C62026	3 X 4000 watt	120/208	single	3 + ground	9.1	43.7	7.4	17.2
		120/220	single	3 + ground	10.1	46.2	8.6	18.0
		120/240	single	3 + ground	12.1	50.4	9.9	18.0
C62036	3 X 3000 watt	120/208	three	4 + ground	7.0	19.5	5.6	12.9
		120/220	three	4 + ground	7.8	20.5	6.5	14.9
		120/240	three	4 + ground	9.1	22.4	7.4	17.2
C62046	3 X 4000 watt	120/208	three	4 + ground	9.2	25.6	7.4	17.2
		120/220	three	4 + ground	10.3	27.1	8.6	18.0
		120/240	three	4 + ground	12.1	29.6	9.9	18.0
C62056	6 X 3000 watt	120/208	three	4 + ground	13.8	38.2	11.2	18.0
		120/220	three	4 + ground	15.4	40.4	12.9	18.0
		120/240	three	4 + ground	18.1	44.0	14.9	18.0
C62066	6 X 4000 watt	120/208	three	4 + ground	18.3	50.7	14.9	18.0
		120/220	three	4 + ground	20.4	53.6	17.3	18.0
		120/240	three	4 + ground	24.1	58.5	18.0	18.0
C62146	6 X 3000 W	480	three	3 + ground	18.1	22.0	14.9	18.0
C62166	6 X 4000 W	480	three	3 + ground	24.1	29.2	18.0	18.0

Steam Heated Version

Electrical Code	Maximum Steam Demand	Steam Pressure	Volts	Wires	Maximum Amp draw	Maximum Batches/Hour
C62986	80 lbs./hr.	10-15 PSI	120	2+ground	0.8	18.0

Dimensions & Utility Connections

CBS-61H

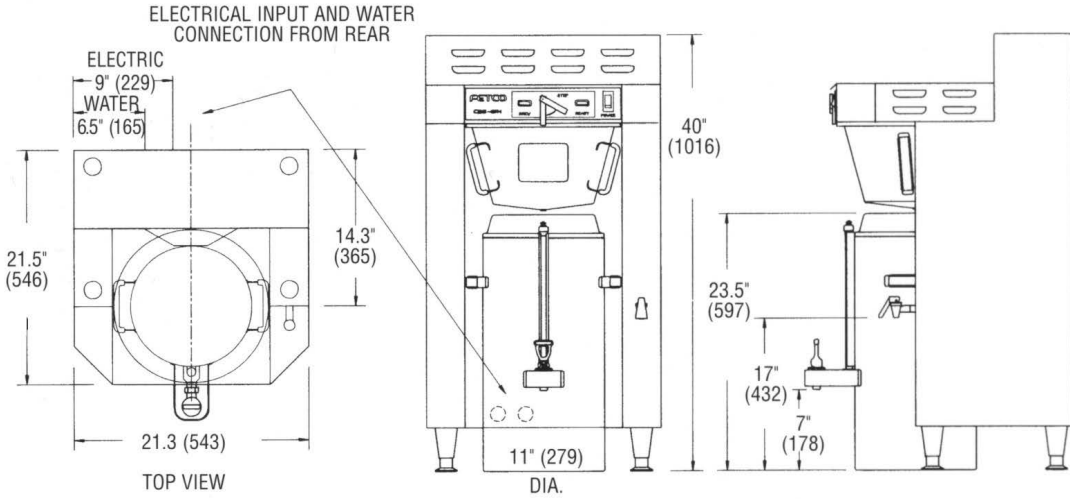

CBS-62H

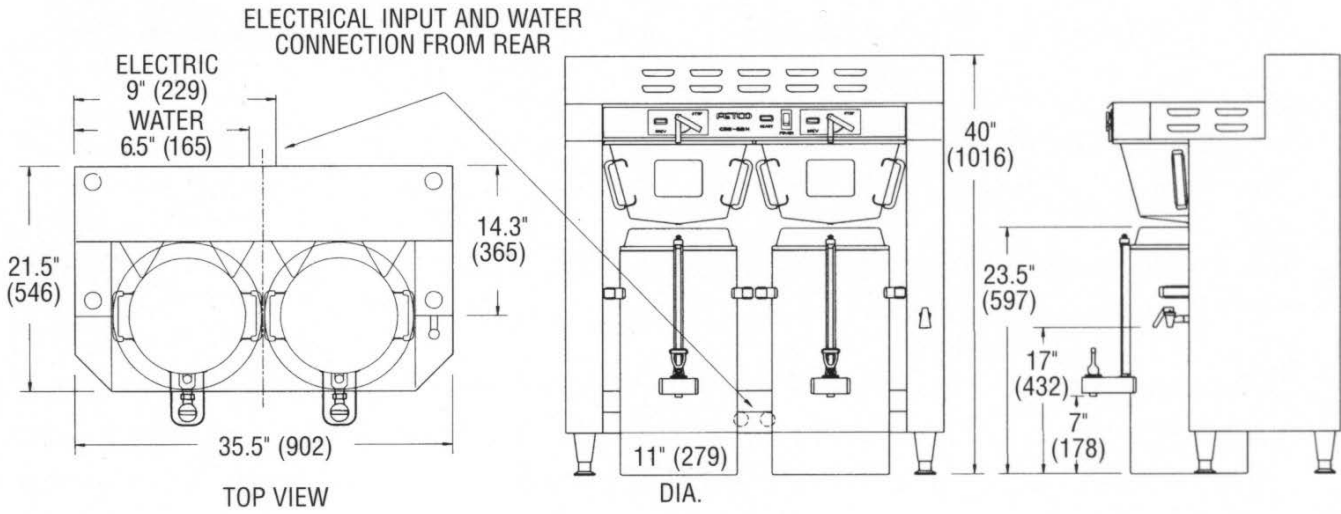

Installation

(For Qualified Service Technicians Only)

Keys To A Successful Installation

If not installed correctly by qualified personnel, the brewer may not operate properly and damage may result. Damages resulting from improper installation are not covered by the warranty. Here are the key points to consider before installation:

Electrical:

- ❖ All FETCO brewers require **NEUTRAL**. Ground is not an acceptable substitute. Installation without neutral may cause damage to the electronic components.
- ❖ The power connection to L2 on the terminal block must be at least 105 volts. Less than 105 volts will cause erratic behavior from the brewer.
- ❖ The power switch has a built-in circuit breaker. To reset it, turn to the “off” position, and then back to the “on” position.
- ❖ The electrical drawing for the brewer is located on the inside of the lower cover.

Plumbing:

- ❖ This equipment is to be installed to comply with the applicable federal, state, or local plumbing codes.
- ❖ The water line must be flushed thoroughly prior to connecting it to the brewer to prevent debris from contaminating the machine.
- ❖ Verify that the water line will provide at least 1 gallon per minute for the CBS-61H, and 2 gallons per minute for the CBS-62H before connecting it to the brewer.

General:

- ❖ Utilize only qualified beverage equipment service technicians for installation. A Service Company Directory may be found on our web site, <http://www.fetco.com>.

Installation Instructions

Brewer Setup

1. Review the Dimensions for the unit you are installing. Verify that the brewer will fit in the space intended for it, and that the counter or table will support the total weight of the brewer and dispensers when filled.
2. The brewer’s legs are shipped inside the brew baskets. Remove the brew basket(s) and the coffee dispenser(s). Place the brewer on its back and screw in the legs.
3. Place the brewer on the counter or stand.
4. When the brewer is in position, level it front to back as well as side to side by adjusting the legs.
5. Remove the lower cover to access the water and electrical connections. Knock-outs are provided in the back and base of the brewer body for the connections.



Warning: Legs are to be adjusted for leveling the brewer only. Do not use for height adjustment or extend them higher than necessary.

Water Connection

1. Water inlet is a 3/8 inch male flare fitting.
2. The brewer can be connected to a cold or hot water line. Cold water is preferred for best coffee flavor, but hot water will allow for faster recovery times.
3. Install a water shut off valve near the brewer to facilitate service. If an in-line water filter is used, it should be installed after the water shut off valve and in a position to facilitate filter replacement.
4. Flush the water supply line and filter **before** connecting it to the brewer.
5. Verify that the water line will provide at least 1 gallons per minute for the CBS-61H, and 2 gallons per minute for the CBS-62H, and that the water pressure is between 20 and 75 psig.
6. Use a wrench on the factory fitting when connecting the incoming water line. This will reduce stress on the internal connections and reduce the possibility of leaks developing after the install has been completed.

Electrical Connections

1. Verify that the actual voltage at the electrical service connection is compatible with the specifications on the brewer's serial number label. Make sure the electrical service includes **neutral**.
2. The temperature and water tank fill level are pre-set at the factory. There is no need to turn off the heaters during the installation process. The control board disables the heaters until the tank is full of water. The heating process will start automatically when the tank has filled.
3. Only 120VAC powered units are shipped from the factory with power cords and plugs attached. For other voltages, a terminal block is provided for connecting the incoming power wires. Consult local codes to determine if a cord and plug can be installed, or if the unit must be hard wired.
4. A fused disconnect switch or circuit breaker on the incoming power line must be conveniently located near the brewer, and its location and markings known to the operators.
5. The body of the brewer must be grounded to a suitable building ground. A ground lug is provided in the brewer next to the power terminal block. Use only 10 gauge copper wire for grounding.
6. Electrical connections must be secured in-place within the unit to meet national and local standards.

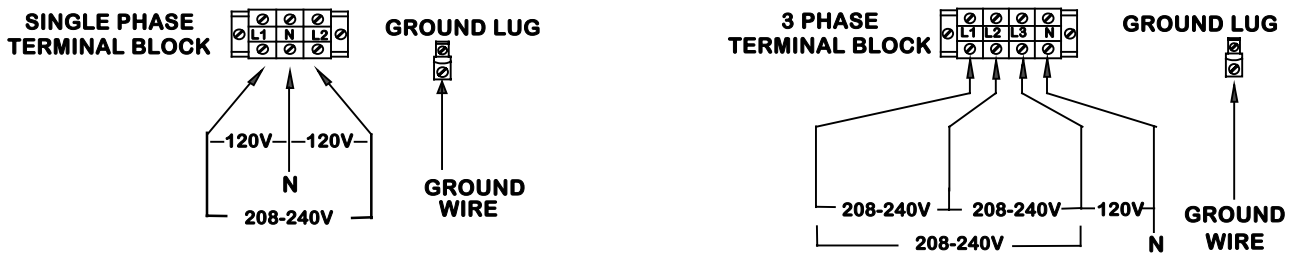
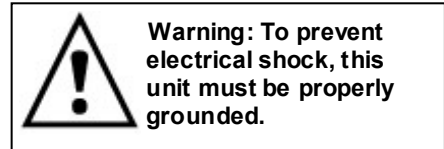

Electrical Configurations – US & Canada

7. Finally, connect the incoming power wires to the terminal block in accordance with applicable codes.

Final Setup

1. Turn on the incoming water supply line and inspect both inside and outside of the brewer for leaks in all fittings and tubes
2. Turn on the incoming power.
3. Turn on the brewer's main power switch.
4. Within 6 seconds, the hot water tank will begin filling until the probe at the top of the tank senses the water.
5. The control board will disable the heaters until the tank is full.
6. The brewer will be ready for operation as soon as the ready light comes on to show that the water tank is up to temperature. The time required to reach brewing temperature will vary according to the electrical configuration ordered.
7. Review the Operating Instructions. Brew one full batch (water only) on each side to confirm proper fill levels. The brewer is factory set with water only (no coffee) to dispense the correct amount of water.
8. Re-attach the covers after one final inspection for leaks. Look closely in the top of the brewer at the dispense fittings during this inspection.

Operating Training

Review the operating procedures with whoever will be using the brewer. Pay particular attention to the following areas:

1. Always pre-heat the dispensers before the first use of each day by filling them half way with hot water, and letting them stand for at least 15 minutes.
2. Don't remove the brew basket until it has stopped dripping.
3. Make sure the dispenser is empty before brewing into it.
4. Show how to attach covers, close, and or secure the thermal dispensers for transporting.
5. Show the location and operation of the water shut off valve as well as the circuit breaker for the brewer.
6. Steam from the tank will form condensation in the vent tubes. This condensation will drip into and then out of the brew baskets. 1/4 cup discharging overnight is possible. Place an appropriate container under each brew basket when not in use.
7. We recommend leaving the power to the brewer on overnight. The water tank is well insulated and will use very little electricity to keep the tank hot. Leaving the brewer in the on position will also avoid delays at the beginning of shifts for the brewer to reach operating temperature.

Operating Procedures

1. Turn brewer on/off switch (E) to the on position

- The power switch will illuminate to indicate that the brewer has power and is operating.
- When the **ready light (F)** illuminates, the brewer is fully up to temperature. The amount of time required to gain full operating temperature will vary depending on the electrical configuration that was ordered, and the temperature of the incoming water.

2. Pre-heat the dispensers.

This step is very important to the overall success of the brewing operation. FETCO avoids the damaging affects of heat on fresh brewed coffee by using highly insulated dispensers. The dispenser must be preheated with hot water from the brewer. This preheating process ensures that the coffee in the first brew starts out hot. Significant heat loss will occur when brewing coffee into a cold dispenser. Preheating is not required for subsequent brews unless the dispenser remains empty for an extended period of time and has cooled down.

- Slide the empty brew basket(s) (D) into their rails and put the empty dispenser(s) in position under the basket for preheating. Select the half batch mode, (A) if you have this option.
- When the ready light illuminates, start a brew cycle by rotating the brew lever (B) to the brew position. This starts clean hot water flowing into the brew basket and then into the dispenser.
- Stop the cycle when each dispenser is approximately 1/2 full by moving the brew lever to the off position. This interrupts the brew cycle and resets the brewer .
- Let the dispensers stand 10-15 minutes, or until use, to allow the heat from the water to be absorbed by the dispensers.

3. Remove the brew baskets from the brewer when you are certain that the flow of hot water has stopped from the bottom of the basket.

- H model brewers will have a safety bar (C) in front of the brew basket to make removing the brew basket a 2-handed operation. This was done to help draw attention to the basket so the operator will notice any residual hot water or coffee.
- Place a paper filter in each basket to be used. Pour into the paper filter the appropriate amount of pre-measured, ground coffee. The amount of coffee used will depend on your personal tastes and the recommendation of your roaster.
- Slide the brew basket back into the rails on the brewer. Insure the latch is outside of the basket.

4. Carefully drain any coffee or preheating water from the dispensers through the faucets before starting a coffee brewing cycle.

- Overflowing of the dispensers may result if the dispensers are not completely empty when the brew cycle begins. Verify by opening the faucet over an appropriate container or drain. The last several cups cannot be seen in the sight gauge tube.
- **CAUTION:** both the coffee or water may still be hot enough to cause burns, so be careful when draining the dispensers

5. Place the thermal dispenser(s) in position under the brew baskets.

- Ensure that the brew funnel is in place, the dispenser is empty, the faucet is closed, and the vent cap on the sight gauge is open.
- The twist lock cover is for transporting the dispenser only. It must be removed before placing the dispenser under the brew basket.

6. Start the brew cycle in the same manner used to start the water used to preheat the dispensers.

- It will not be necessary to interrupt the cycle while brewing coffee. The brewer will return to the stopped and ready status automatically.
- It is normal for the ready light to go out after the start of the brew cycle. On twin brewers, there is enough hot water in the brewer to support a second brew, even if the ready light is off. After brewing on both sides, you must wait for the ready light to come back on.
- The electrical configuration and the electrical power connected to the brewer will determine how long before the ready light comes back on for the next brew.

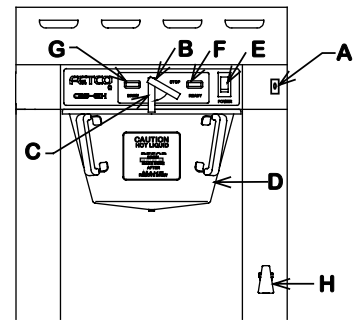

Legend:

- A**-Full/half batch switch
- B**-Brew lever
- C**-Safety bar
- D**-Brew basket
- E**-On/off switch
- F**-Ready light
- G**- Brew light
- H**- Hot water faucet

CAUTION

- Do not remove the brew basket immediately after the brew cycle has finished. Wait until dripping from the bottom of the brew basket has stopped. Carefully remove the brew basket while inspecting the inside of the basket for hot coffee that may have been trapped or has not finished draining.

TPD- 3.0 LUXUS Dispensers:

The LUXUS dispensers are super insulated. They will hold a 195 degree beverage hot for extended periods of time. A full LUXUS will typically lose only 4 degrees per hour if the dispenser is preheated first with hot water.

Closing a LUXUS dispenser for transportation or storage must be done in the following steps to avoid spraying beverages from the top of the sight gauge. Failure to follow these steps in order can cause a hydraulic reaction. By moving the funnel vent cap down on the larger surface area of the main body an upward movement amplified many times is created in the sight gauge. This forces the fluid out the top of the sight gauge vent.

1. Install the twist lock cover, ensuring that the safety lock engages.
2. Close the sight gauge vent plug.
3. Close the twist lock cover funnel vent cap.
4. Open the LUXUS by reversing the above order. Open the funnel vent cap first, then the sight gauge vent cap.

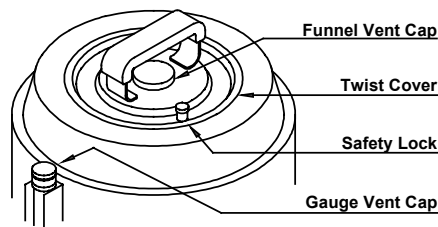

Because the faucet body is metal, it will dissipate the beverage temperature over time. This temperature loss is more noticeable with hot beverages than cold. If a dispenser of hot coffee goes unused, the first ounce or two will be cool and should be discarded. Subsequent cups will be hot.

Cleaning:

Use the same techniques and products as you would use to clean any coffee urn i.e.

- a) the sight gauge brush to scrub the gauge
- b) urn brush for inside the dispenser
- c) urn cleaner to clean the dispenser
- d) stainless steel polish for the outside
- e) hot water and towels for the faucet parts

Service

Warranty

All FETCO brewers come with a limited warranty. All warranty service must be authorized by calling the FETCO Service Department at (800) 338-2699.

Principles of Operation

Fill System

The fill system consists of a liquid level control board, a water level probe at the top of the tank, a fill valve, and a fill tube. As the water rises and touches the probe, continuity is established between the probe tip and the tank body, and the fill valve closes.

When water is dispensed, the water level drops below the probe. After a 5 second delay, the fill valve opens until the water touches the probe again.

The 5 second delay, and the speed that water refills the tank during brewing, results in many short bursts of water. The sound made by these repetitive bursts will let you know the fill system is functioning normally.

The fill system is designed to protect the heaters during both the installation and a loss of the water supply. During initial installation, or whenever the power switch is turned on, voltage will not be supplied to the thermostat until the tank fills and water touches the water level probe.

During operation, when water is dispensed and the water level drops below the probe, a fill signal is sent to the fill valve. If the probe does not sense water after 40 seconds, the voltage to the thermostat and the heaters is removed.

Water enters the tank through the fill tube. A hole is drilled in the upper portion of the fill tube to prevent water from being siphoned from the tank. The fill tube extends to the bottom area of the tank. This introduces cold incoming water directly to the heaters and away from the dispense assembly.

The water tank can be drained through a valve located inside the lower compartment of the brewer.

Temperature System:

The temperature system consists of an electronic thermostat, a temperature probe, and heating elements, and is enabled by the liquid level control board. (See the previous section - Fill Circuit.)

When the water level probe is in contact with water, power is delivered to the thermostat through the liquid level control board. If the temperature probe senses that the water is not hot enough, the thermostat energizes the heating elements through the solid state relay (SSR), the water is heated, and the ready light goes off.

Once the water temperature reaches the set point, the thermostat disengages power to the heaters and the ready light illuminates.

The thermostat is adjusted to $205^{\circ}\text{ F} \pm 2^{\circ}$ at the factory. (Slightly lower for high altitude installations.)

Timing System:

The timing system consist of the timer and the dispense latch assembly.

When the brew handle is rotated from the stop to the brew position, it pushes the plunger in the latch coil and closes the micro switch, and the timer starts the timed cycle. It also starts the hot water flowing.

The timer energizes the dispense latch coil, which acts as a magnet, to hold the brew handle in the brew position. It also lights the brew light. The coil remains energized throughout the brew cycle timed sequence.

When the timer finishes its cycle, it removes voltage from the latch coil. The latch coil then releases the brew handle, a spring returns it to the stop position, and the flow of water stops. This return opens the micro switch, stopping voltage from going to the timer. The brew light and the timer are disabled, and wait for the brew handle to engage the next brew cycle.

The timer used with the 1/2 batch option has a small jumper wire on one end. A switch can replace this jumper to open or close this connection. Opening this connection cuts the timed output in half.

Dispense System:

The dispense system is completely mechanical. It is one of the areas that makes FETCO's brewer truly unique. (See the illustration in this section.)

When you rotate the brew lever down to brew, the end of the dispense tube is submerged in the hot water tank. It is held in the brew position by the magnetic action of the dispense latch coil.

The brew water travels down the dispense tube to the sprayhead assembly. The flow disc above the spray cutter controls the rate of flow over the coffee. The standard hole in the flow disc is .281". Other flow discs are available for special situations like high levels of by-pass.

The sprayhead can be assembled incorrectly during cleaning. Refer to the cleaning label on the brewer for proper assembly. The flow disc has the flange down, flat side up. The six-triangle spray cutter has the flange up. The eight-hole spray cutter used in place of the triangle cutter goes bumps down.

A bypass valve and tube are connected to the sprayhead. This valve directs brew water around the outside edge of the filter paper. The by-pass valve is shipped in the closed position from the factory. Each time the valve is adjusted, the brew volume is affected. Adjustment of the by-pass valve is for flavor only. When the timer circuit releases the brew latch, the dispense tube pops back above the hot water level. The remaining brew water drains from the dispense system leaving it free of standing water. Steam escaping from the brew tank through this tube inhibits the formation of lime in the brew system.

The dispense system is clean & semi dry for all but the brief time required for the brew cycle. This eliminates any chance of lime build-up affecting the brew cycle.

It is very easy to dislodge the dispense tube seals while servicing the dispense system. If you see it leaking profusely, remove the nut and dispense tube. Reset the seal fully into the recess and carefully insert the dispense tube. Then secure the locknut before you back the tube into position. (See detailed instructions on page 10.

Mechanical Illustration - Dispense System

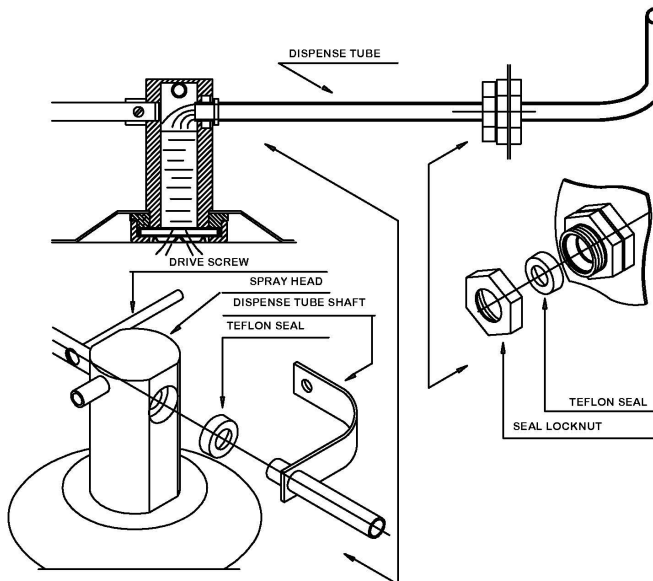
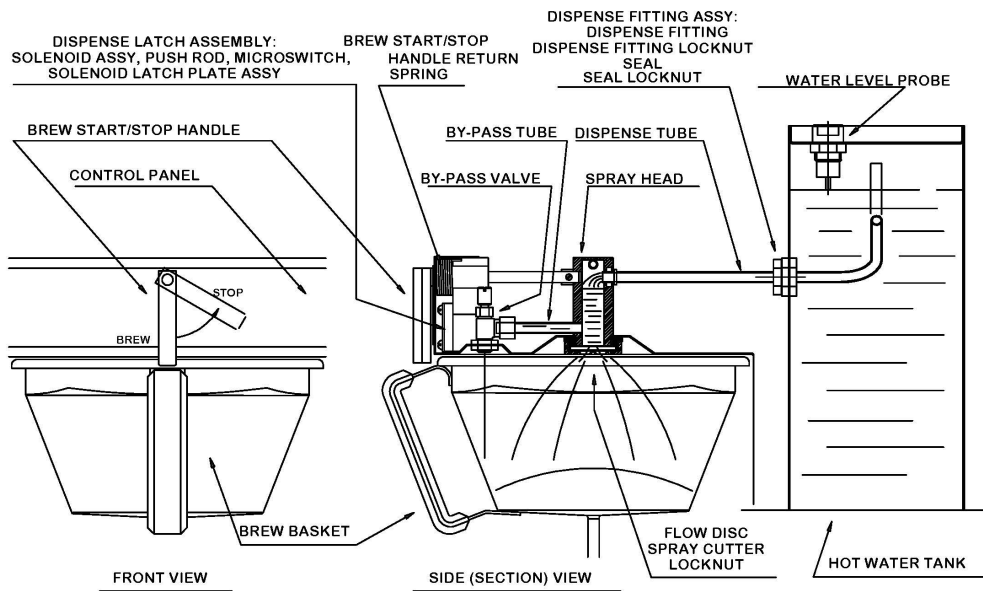

To remove the dispense tube:

1. Unscrew seal locknut and release the drive screw from dispense tube shaft.
2. Turn the dispense tube slightly back and forth, while pushing the tube into the hot water tank until it is free from the sprayhead.
3. Pull the dispense tube out of the tank. Remember the tube is bent inside the tank. The seal will come out with the tube.

To install the dispense tube:

1. Clean any lime build up off the tube and then slide the seal off. Push the seal carefully into its chamber in the fitting. (spring towards the hot water tank.)
2. Place the seal locknut onto the tube and slide the tube into the seal. Tighten the seal locknut.
3. Work the tube back into the sprayhead seal.
4. Join the dispense tube shaft and the brew handle shaft with the drive screw.

Adjustments

Thermostat Adjustment:

During normal operation, the digital readout displays the last two digits of the actual water temperature. When the adjustment tool is turned, the readout begins flashing to indicate the set point, not the actual temperature. After the tool is released, the readout stops flashing and displays the actual temperature again.

A red LED lights when the power to the thermostat is on. A yellow LED lights when the thermostat is calling for heat.

To adjust, turn the adjustment tool. If no adjustment tool is present, a small flat-head screwdriver may be used. The display will flash, indicating that the display is showing the set point, not the actual temperature.

The default temperature scale is Fahrenheit. When set to Fahrenheit, the display shows only the last 2 digits of the temperature.

Examples:

75 = 75°F

87. = 187°F

03. = 203°F

The dots below the numbers indicate the temp range.

0 dots – less than 100° F

1 dot – between 100° and 200° F

2 dots – over 200° F

Timer Adjustment:

The timer has two independent settings, with three dials for each setting. The first dial in each group sets 100 second increments, the second dial sets 10 second increments, and the third dial sets 1 second increments.

A red LED lights when the power to the timer is on. A yellow LED lights when the timer is running.

A small flat head screwdriver is required to adjust the dials.

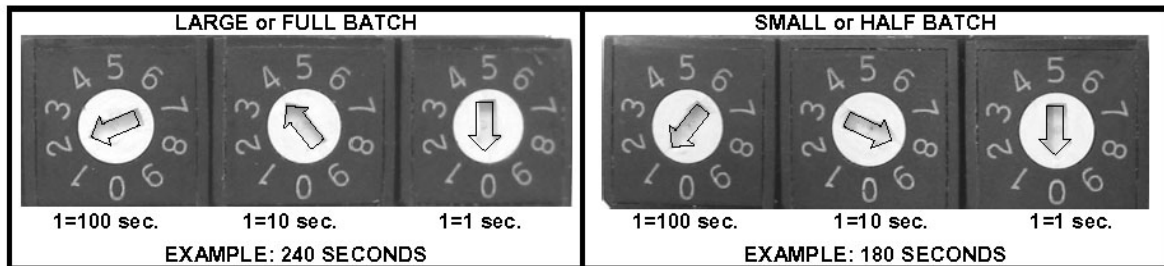

part # K034, digital timer, 100-120 VAC

part # K036, digital timer, 200-240 VAC (export versions only)

Water Level Control Board

The board features a jumper to adjust its' sensitivity to reverse osmosis or other types of ultra-pure water.

The default jumper setting is LO for normal water. If the brewer tank overfills because of ultra-pure water, the jumper should be set to HI.

A red LED lights when the power to the board is on.

A green LED lights when the water level probe detects that the tank is full.

A yellow LED lights when the FILL circuit is energized.

A second yellow LED lights when the HEAT circuit is energized.

Bypass Adjustment:

The purpose of the bypass valve is to allow a portion of the brewing water to flow between the brew basket and the wire insert, directly into the server, without coming in contact with the coffee grounds. The bypass can be adjusted from 0% to 33% of the total brewing water. Dual brewers (CBS-62H), have separate bypass valves on each side. Unless requested at the time of order, all brewers are shipped with the bypass valves closed (0%). Adjusting the bypass always changes the total brew volume, so the timer setting must always be checked and adjusted.

To adjust the bypass:

- Remove the brewer's upper cover.
- The bypass valve is located above the brew basket, to the right and to the front.
- Remove the brew basket.
- Place a container under the spray head and a separate container under the bypass hole.
- Turn the bypass valve clockwise to decrease, and counter-clockwise to increase the bypass amount. A good starting point would be one full turn for each 5% change.
- Brew a full cycle and measure the amount of water in both containers.
- The ratio of the bypass water to the total in both containers is the bypass percentage.
Example: $\frac{1}{2}$ gal. bypass + 2.5 gal. from spray head = 3 gal. total. Bypass = 16.66%.
- Several adjustments may be necessary until the desired results are achieved.

Dispenser Parts

LUXUS® TPD- 3.0

Reference Number	Part Number	Description
1	71026	faucet, complete, black handle (ES)
1	71037	faucet upper assy. w/black handle (handle, spring, seat cup and nut)
1	71035	faucet seat cup
1	71028	faucet handle- black
1	71027	faucet handle, decaf faucet (orange)
2	31045	faucet union nut
3	71036	faucet "c" ring
4	102052	faucet shank assembly
5	24009	faucet shank "o" ring 1/2" x 3/4"
6	12018	vent top plug
7	71017	sight gauge washer lower
8	71024	sight gauge cap
9	71018	sight gauge washer upper
6-9	102020	sight gauge cap and vent assy.
10	21035	sight gauge tube 12-1/2" (plastic)
10	71033	sight gauge tube 12-1/2" (glass)
11	82015	faucet shank screw-2 required
12	101038	twist lock cover assembly
13	101051	brew funnel assembly
15	41011	LUXUS label

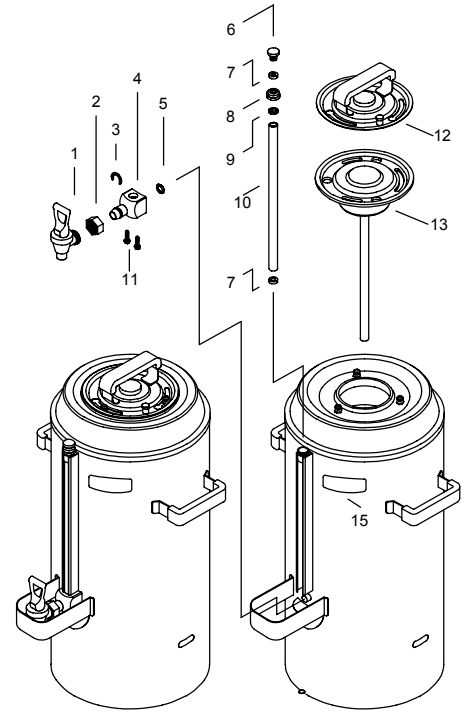

Brewer Parts

Figure 1 – CBS-61H Main Assembly

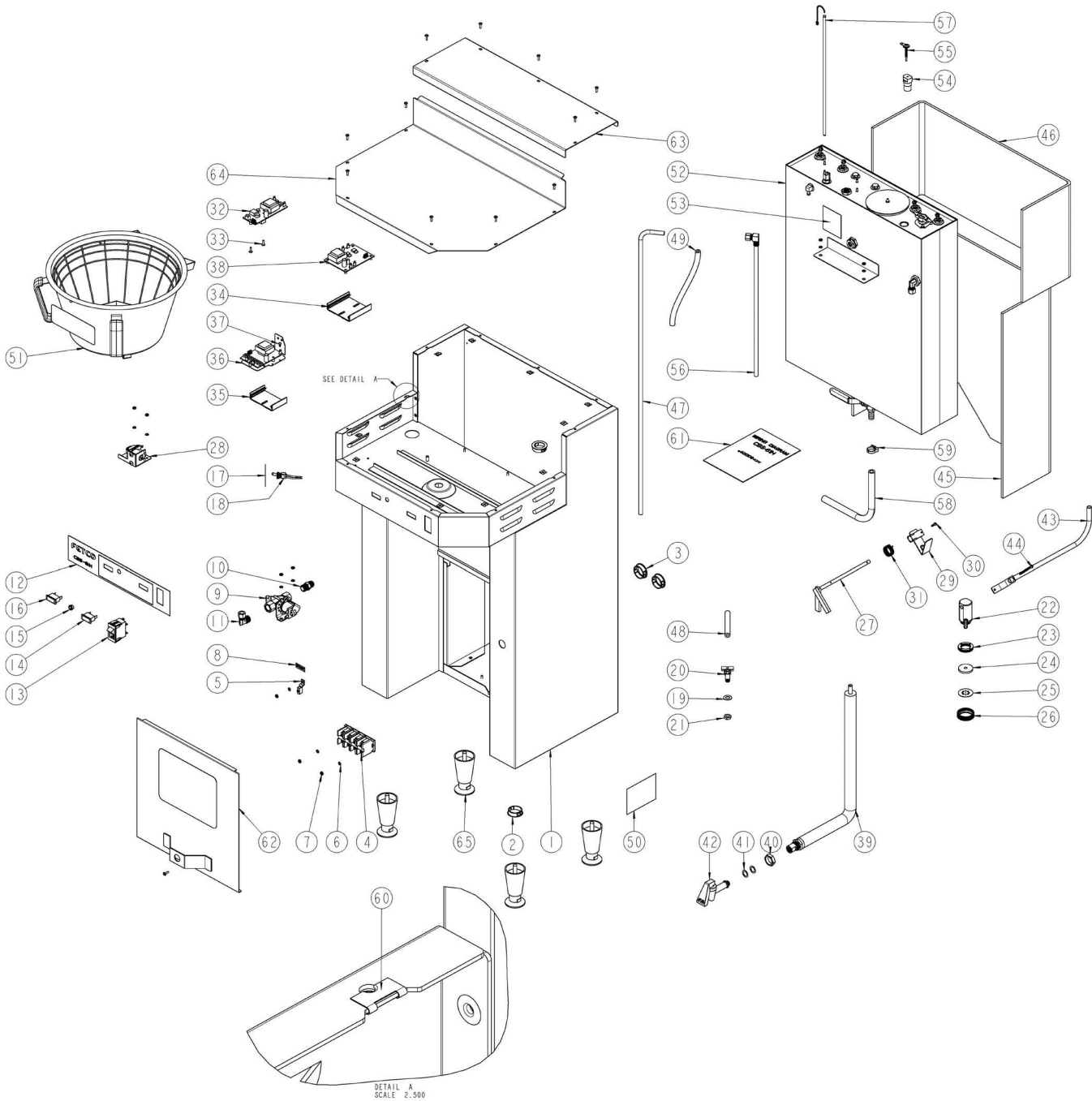

ITEM #	QTY	PART #	DESCRIPTION
1	1	001062	WELDMENT, CBS-61 H
2	1	86018	PLUG, DOME, 1.375 MOUNTING HOLE
3	3	86021	BUSHING, SNAP, 1.375 MTG HOLE
4	1	102104	ASSEMBLY, TERMINAL BLOCK
5	1	65002	CONNECTOR, COPPER LUG
6	9	83026	WASHER, INTERNAL TOOTH LOCK, #8 SCREW SIZE
7	9	84002	NUT, HEX, #8-32 MACHINE SCREW
8	1	44004	LABEL GROUND

9	1	102323	VALVE, S-45 120VAC	
9	1	57022	VALVE, S-45 240VAC	EXPORT ONLY
10	1	31001	FITTING, FILL VALVE INLET	
11	1	31055	FITTING, FILL VALVE INLET	
12	1	45017	OVERLAY, CBS-61 H	
13	1	52077	BREAKER,CIRCUIT 120VAC ROCKER SWITCH 6 AMP	
13	1	52076	BREAKER,CIRCUIT 220VAC ROCKER SWITCH 6 AMP	EXPORT ONLY
14	1	58027	LAMP, READY INDICATOR, GREEN 120VAC	
14	1	58006	LAMP, READY INDICATOR, GREEN 220VAC	EXPORT ONLY
15	1	86001	BUSHING, .312 X .500" HEAD DIA. SHORTY	
16	1	58026	LAMP, BREW 120VAC	
16	1	58004	LAMP, BREW 220VAC	EXPORT ONLY
17	1	46010	LABEL, FULL/HALF BREW	
18	1	102359	SWITCH, FULL/HALF, TOGGLE	
19	1	83041	WASHER, .812"OD X .412"ID, FLAT	
20	1	102028	ASSEMBLY, BYPASS, CBS-60'S, 50'S	
21	1	31116	LOCKNUT 1/8"-27 NPT	
22	1	102267	ASSEMBLY, SPRAY HEAD, CBS-60'S	
23	1	33002	LOCKNUT, SPRAY HEAD	
24	1	05016	DISK, FLOW, SPRAY CUTTER, .281 DIA	
25	1	05014	SPRAY CUTTER	
26	1	31015	LOCKNUT, SPRAY CUTTER	
27	1	102012	ASSEMBLY, HANDLE, DISPENSE	
28	1	102008	ASSEMBLY, DISPENSE SOLENOID LATCH, 120 VAC	
28	1	102039	ASSEMBLY, DISPENSE SOLENOID LATCH, 220 VAC	EXPORT ONLY
29	1	102269	ASSEMBLY, DISPENSE LATCH, CBS-60'S	
30	1	82004	SCREW, 6-32 X 5/8" RND HEAD PHILLIPS	
31	1	85004	SPRING, BREW HANDLE RETURN	
32	1	K033	DIGITAL THERMOSTAT KIT, 100-120VAC	
32	1	K035	DIGITAL THERMOSTAT KIT, 200-240VAC (EXPORT)	EXPORT ONLY
33	14	82053	SCREW, # 6-32 X 1/2" TRUSS HD PH	
34	1	002245	WELDMENT, CONTROL BOARD PLASTIC TRACK, CBS-60'S, 3"LG.	
35	1	002244	WELDMENT, TIMER PLASTIC TRACK, CBS-60'S, 2"LG	
36	1	K034	DIGITAL TIMER KIT, 100-120VAC	
36	1	K036	DIGITAL TIMER KIT, 200-240VAC	EXPORT ONLY
37	1	82130	SCREW, #6 X 3/8" LG, SHEET METAL, ROUND HEAD PHIL.	
38	1	108034	ASSEMBLY, BOARD, WATER LEVEL, CONTROL, 100-120 VAC, 50-100K ohm	
38	1	108035	ASSEMBLY, BOARD, WATER LEVEL, CONTROL, 200-240 VAC, 50-100K ohm	EXPORT ONLY
39	1	102017	ASSEMBLY, HOT WATER SPOUT	
40	1	13022	LOCKNUT, FAUCET SMALL	
41	2	83047	WASHER, FIBER, ID 0.5 X 0.75 OD	
42	1	71021	FAUCET HPSC-BR-8 REGULAR HANDLE (COMPLETE FAUCET)	
	1	71039	FAUCET, UPPER ASSY. (SUBCOMPONENT OF #42)	
	1	71003	FAUCET SEAT CUP (SUBCOMPONENT OF #42)	
43	1	002011	WELDMENT, DISPENSE TUBE, CBS-60'S	
44	1	82018	SCREW, 8-32 X 2-1/4" LG	
45	1	22100	INSULATION, TANK LOWER, CBS-61 H	
46	1	22099	INSULATION, TANK UPPER, CBS-61 H	
47	1	32035	TUBE, FILL VALVE - TANK WATER INLET	
48	1	25112	TUBE, 1/2 OD X 1/4 ID X 4.00 LG BREW, CBS-60's H	
49	1	25002	TUBE, 1/2 OD X 1/4 ID X 9.00 LG, VENT, CBS-60's H	
51	1	101050	ASSEMBLY, BREW BASKET, CBS-60'S	
	1	09005	WIRE INSERT, 21 X 7 (SUBCOMPONENT OF #51)	
	1	09009	WIRE INSERT .18 X 7-1/2" (HALF-BATCH) (SUBCOMPONENT OF #51)	
52	1	*	ASSEMBLY, TANK, CBS-61H, SSR (SEE FIG. 2)	
53	1	44024	LABEL, WARNING-HIGH VOLTAGE	
54	1	21026	HOUSING, WATER LEVEL PROBE 0.140" DIA.	
55	1	002010	WELDMENT, WATER LEVEL PROBE, 1.75" LG	
56	1	002035	WELDMENT, COLD WATER TUBE INLET, CBS-60'S	
57	1	K065	ASSEMBLY, DIGITAL TEMP. PROBE, 14.0"LG W/3/4" CABLE	
58	1	25046	TUBE, 5/8"OD X 3/8"ID X 15"LG, DRAIN	
59	1	86038	CLAMP, HOSE, .670"-.780" DIA RANGE	
60	12	84051	NUT, CLIP ON (J-NUT), #6-32, 18 -16 GA., BLACK-PHOSPHATE FINISH	
61	1	*	WIRING DIAGRAM CBS-61H SSR	
62	1	002015	WELDMENT, FRONT COVER, CBS-61H	
63	1	01748	COVER, TOP CBS-61H, NEW DESIGN	
64	1	01747	COVER, UPPER BASE CBS-61H NEW DESIGN	
65	4	73011	LEG, FLANGE FOOT, 4" HIGH	

* For tank assembly and wiring diagram part numbers, call Tech Support at 800-338-2699. Provide the brewer serial number when calling.

Figure 2 – CBS-61H Tank Assembly

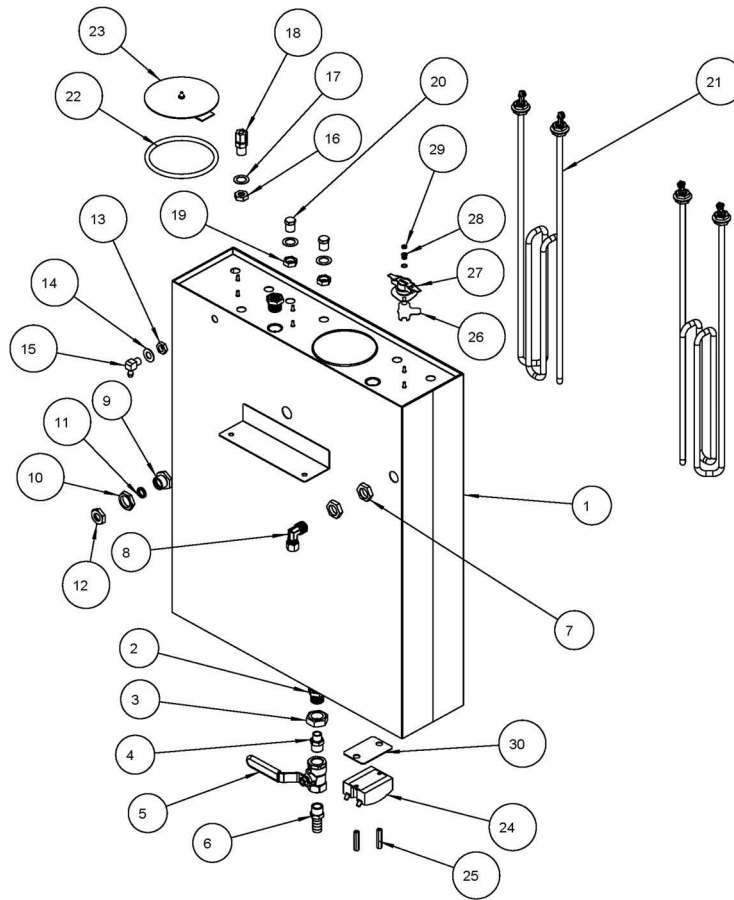

DWG 104077-B

ITEM #	QTY	PART #	DESCRIPTION
1	1	004074	WELDMENT, TANK CB3 61 H , SSR
2	2	31021	BUSHING, 3/4-16 X 1/4 NPSM, HEX HEAD
3	1	84007	NUT, 3/4-16 HEX JAM
4	1	31082	FITTING, HEX NIPPLE, 3/8 MPT X 1/4 MPT
5	1	34004	VALVE, BALL 3/8 FPT X 3/8 FPT
6	1	31054	FITTING, 1/2 HOSE ID X 3/8 MPT
7	2	31118	LOCKNUT 3/8"-18 NPT
8	1	31055	FITTING, FILL VALVE INLET
9	1	33006	FITTING, TANK, (7/16 DIA DISPENSE TUBE)
10	1	33007	LOCKNUT, 7/16 STRAIGHT PIPE THREAD
11	1	24008	SEAL, DISPENSE TUBE, 7/16"DIA
12	1	31052	LOCKNUT, 7/16", DISPENSE TUBE SEAL, KEEPER
13	1	31116	LOCKNUT 1/8"-27 NPT
14	1	83041	WASHER, .812"OD X .412"ID, FLAT
15	1	31005	FITTING, 90 DEG. ELBOW, 1/4 HOSE ID X 1/8 MPT
16	1	23249	LOCKNUT 1/4"-18 NPT MODIFIED THREAD
17	3	83042	WASHER, .875"OD X .562"ID, FLAT
18	1	25098	FITTING, COMPRESSION MALE CONNECTOR
19	2	31117	LOCKNUT 1/4"-18 NPT
20	2	31081	PLUG, HEX HEAD 1/4" MPT
21	2 or 3	107002	ASSEMBLY, IMMERSION HEATER, 3000W, 240VAC
21	2 or 3	107003	ASSEMBLY, IMMERSION HEATER, 4000W, 240VAC
22	1	24002	O-RING, TANK COVER
23	1	102013	ASSEMBLY, TANK COVER
24	1	108071	ASSEMBLY, RELAY, SOLID STATE, 50 A/ 600V
25	2	15013	STANDOFF, 6-32 x1.25 LG., 1/4 HEX WIDTH
26	1	03332	BRACKET 2, ONE SHOT THERMOSTAT
27	1	53088	THERMOSTAT, SINGLE SHOT, 240V/40A
28	2	83011	WASHER, #6 SCREW SIZE, INTERNAL
29	2	84045	NUT, HEX 6-32, UNDERSIZED
30	1	03443	ALUMINUM BRACKET FOR SSR

For tank assembly and wiring diagram part numbers, call Tech Support at 800-338-2699. Provide the brewer serial number when calling.

Figure 3 – CBS-62H Main Assembly

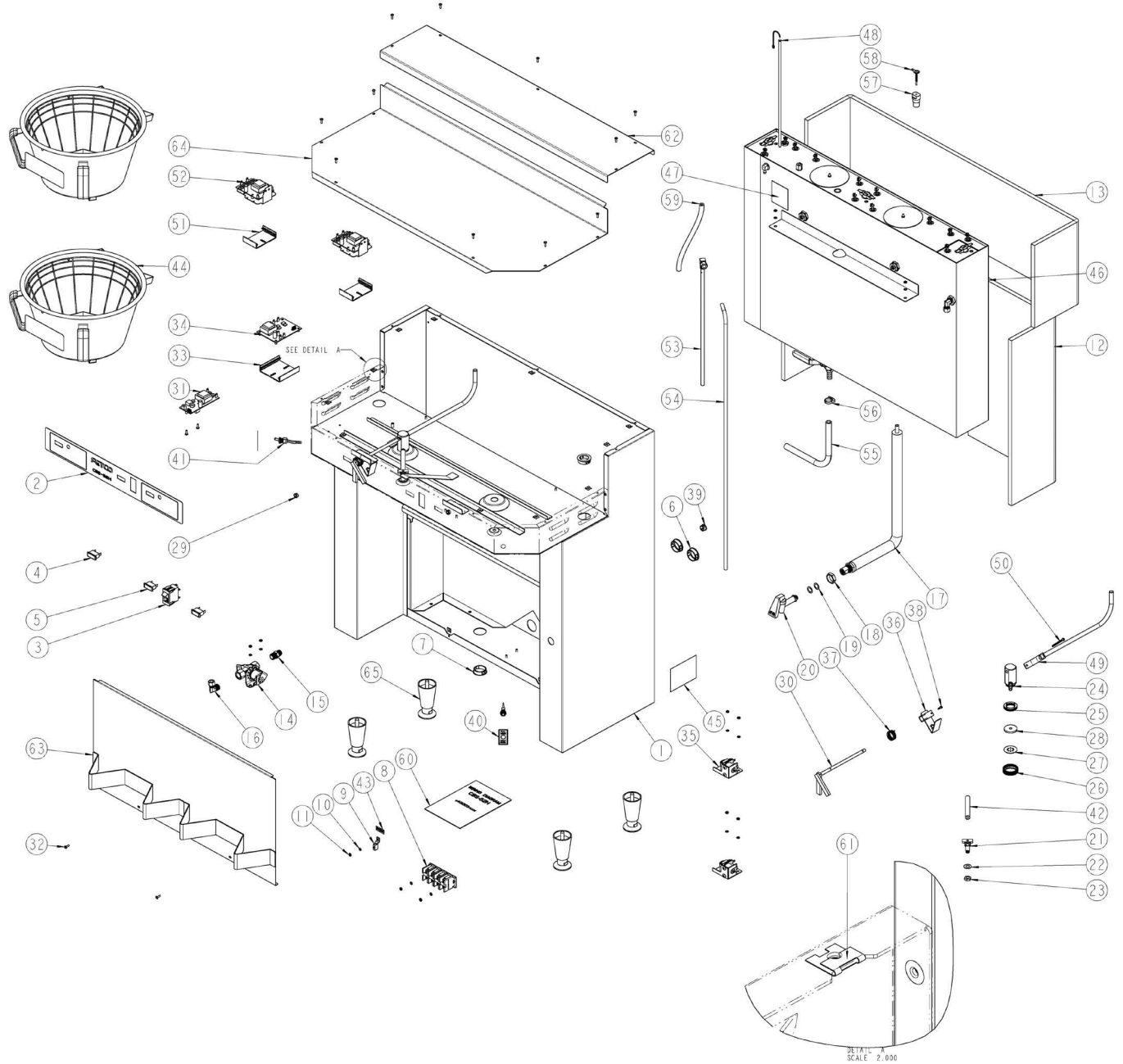

DWG 101254-A

ITEM #	QTY	PART #	DESCRIPTION	
1	1	001061	WELDMENT, CBS-62 H	
2	1	45028	OVERLAY CBS-62 H	
3	1	52077	BREAKER, CIRCUIT 120VAC ROCKER SWITCH 6 AMP	
3	1	52076	BREAKER, CIRCUIT 220VAC ROCKER SWITCH 6 AMP	EXPORT ONLY
4	2	58026	LAMP, BREW 120VAC	
4	2	58004	LAMP, BREW 220VAC	EXPORT ONLY
5	1	58027	LAMP, READY INDICATOR, GREEN 120VAC	
5	1	58006	LAMP, READY INDICATOR, GREEN 220VAC	EXPORT ONLY
6	3	86021	BUSHING, SNAP, 1.375 MTG HOLE	
7	1	86018	PLUG, DOME, 1.375 MOUNTING HOLE	
8	1	102104	ASSEMBLY, TERMINAL BLOCK	
9	1	65002	CONNECTOR, COPPER LUG	
10	11	83026	WASHER, INTERNAL TOOTH LOCK, #8 SCREW SIZE	
11	11	84002	NUT, HEX, #8-32 MACHINE SCREW	

12	1	22098	INSULATION, TANK LOWER PART, CBS-62 H	
13	1	22097	INSULATION, TANK UPPER PART, CBS-62 H	
14	1	102323	VALVE, S-45 120VAC	
14	1	57022	VALVE, S-45 240VAC	EXPORT ONLY
15	1	31001	FITTING, FILL VALVE INLET	
16	1	31055	FITTING, FILL VALVE INLET	
17	1	102017	ASSEMBLY, HOT WATER SPOUT	
18	1	13022	LOCKNUT, FAUCET SMALL	
19	2	83047	WASHER, FIBER, ID 0.5 X 0.75 OD	
20	1	71021	FAUCET HPSC-BR-8 REGULAR HANDLE (COMPLETE FAUCET)	
	1	71039	FAUCET, UPPER ASSY. (SUBCOMPONENT OF #20)	
	1	71003	FAUCET SEAT CUP (SUBCOMPONENT OF #20)	
21	2	102028	ASSEMBLY, BYPASS, CBS-60'S, 50'S	
22	2	83041	WASHER, .812"OD X .412"ID, FLAT	
23	2	31116	LOCKNUT 1/8"-27 NPT	
24	2	102267	ASSEMBLY, SPRAY HEAD, CBS-60'S	
25	2	33002	LOCKNUT, SPRAY HEAD	
26	2	31015	LOCKNUT, SPRAY CUTTER	
27	2	05014	SPRAY CUTTER	
28	2	05016	DISK, FLOW, SPRAY CUTTER, .281 DIA	
29	2	86001	BUSHING, .312 X .500" HEAD DIA. SHORTY	
30	2	102012	ASSEMBLY, HANDLE, DISPENSE	
31	1	K033	DIGITAL THERMOSTAT KIT, 100-120VAC	
31	1	K035	DIGITAL THERMOSTAT KIT, 200-240VAC (EXPORT)	EXPORT ONLY
32	15	82053	SCREW, # 6-32 X 1/2" TRUSS HD PH	
33	1	002245	WELDMENT, CONTROL BOARD PLASTIC TRACK, CBS-60'S, 3"LG.	
34	1	108034	ASSEMBLY, BOARD, WATER LEVEL, CONTROL, 100-120 VAC, 50-100K ohm	
34	1	108035	ASSEMBLY, BOARD, WATER LEVEL, CONTROL, 200-240 VAC, 50-100K ohm	EXPORT ONLY
35	2	102008	ASSEMBLY, DISPENSE SOLENOID LATCH, 120 VAC	
35	2	102039	ASSEMBLY, DISPENSE SOLENOID LATCH, 220 VAC	EXPORT ONLY
36	2	102269	ASSEMBLY, DISPENSE LATCH, CBS-60'S	
37	2	85004	SPRING, BREW HANDLE RETURN	
38	2	82004	SCREW, 6-32 X 5/8" RND HEAD PHILLIPS	
39	1	86046	PLUG, NYLON FINISHING LOCKING, 0.625" MOUNTING	
40	2	46010	LABEL, FULL/HALF BREW	
41	2	102359	SWITCH, FULL/HALF, TOGGLE	
42	2	25112	TUBE, 1/2 OD X 1/4 ID X 4.00 LG BREW, CBS-60's H	
43	1	44004	LABEL GROUND	
44	2	101050	ASSEMBLY, BREW BASKET, CBS-60'S	
	2	09005	WIRE INSERT, 21 X 7 (SUBCOMPONENT OF #44)	
	2	09009	WIRE INSERT, 18 X 7-1/2" (HALF-BATCH) (SUBCOMPONENT OF #44)	
45	1	42005	LABEL, 4" X 3" SERIAL NUMBER	
46	1	*	ASSEMBLY, TANK, CBS-62H SSR	
47	1	44024	LABEL, WARNING-HIGH VOLTAGE	
48	1	K065	ASSEMBLY, DIGITAL TEMP. PROBE, 14.0"LG W/34" CABLE	
49	2	002011	WELDMENT, DISPENSE TUBE, CBS-60'S	
50	2	82018	SCREW, 8-32 X 2-1/4" LG	
51	2	002244	WELDMENT, TIMER PLASTIC TRACK, CBS-60'S, 2"LG	
52	2	K034	DIGITAL TIMER KIT, 100-120VAC	
52	2	K036	DIGITAL TIMER KIT, 200-240VAC	EXPORT ONLY
53	1	002035	WELDMENT, COLD WATER TUBE INLET, CBS-60'S	
54	1	32035	TUBE, FILL VALVE - TANK WATER INLET	
55	1	25046	TUBE, 5/8"OD X 3/8"ID X 15"LG, DRAIN	
56	1	86038	CLAMP, HOSE, .670"-.780" DIA RANGE	
57	1	21026	HOUSING, WATER LEVEL PROBE 0.140" DIA.	
58	1	002010	WELDMENT, WATER LEVEL PROBE, 1.75" LG	
59	1	25002	TUBE, 1/2 OD X 1/4 ID X 9.00 LG, VENT, CBS-60's H	
60	1	*	WIRING DIAGRAM CBS-62H SSR	
61	13	84051	NUT, CLIP ON (J-NUT), #6-32, 18 -16 GA., BLACK-PHOSPHATE FINISH	
62	1	01745	COVER, TOP CBS-62H, NEW DESIGN	
63	1	002236	WELDMENT, FRONT COVER CBS-62 H	
64	1	01744	COVER, UPPER BASE CBS-62H NEW DESIGN	
65	4	73011	LEG, FLANGE FOOT, 4" HIGH	

* For tank assembly and wiring diagram part numbers, call Tech Support at 800-338-2699. Provide the brewer serial number when calling.

Figure 4 – CBS-62H Tank Assembly

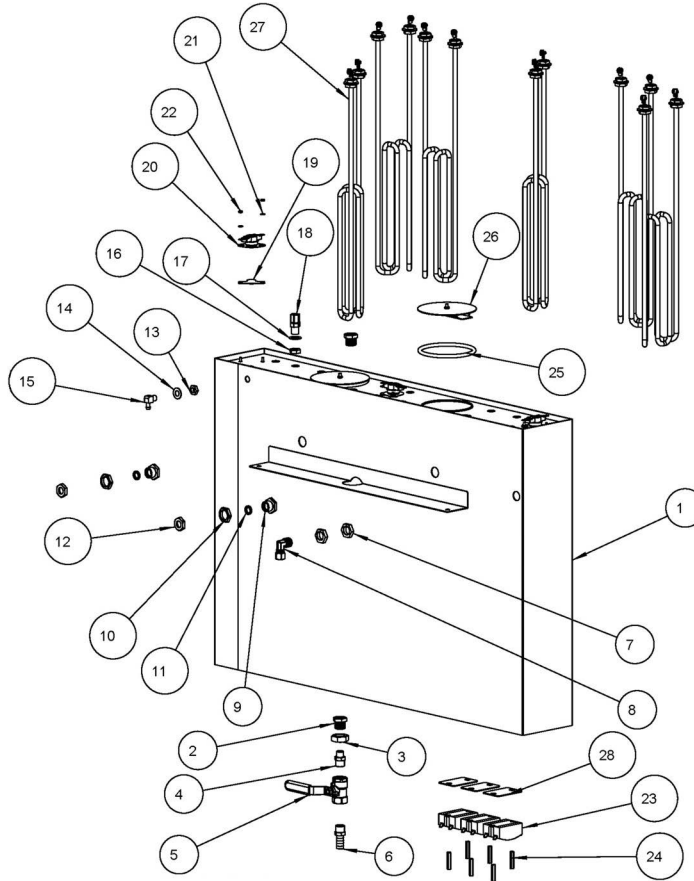

DWG 104078-A

ITEM #	QTY	PART #	DESCRIPTION
1	1	004075	WELDMENT, TANK CBS-62 H, SSR
2	2	31021	BUSHING, 3/4-16 X 1/4 NPSM, HEX HEAD
3	1	84007	NUT, 3/4-16 HEX JAM
4	1	31082	FITTING, HEX NIPPLE, 3/8 MPT X 1/4 MPT
5	1	34004	VALVE, BALL 3/8 FPT X 3/8 FPT
6	1	31054	FITTING, 1/2 HOSE ID X 3/8 MPT
7	2	31118	LOCKNUT 3/8"-18 NPT
8	1	31055	FITTING, FILL VALVE INLET
9	2	33006	FITTING, TANK, (7/16 DIA DISPENSE TUBE)
10	2	33007	LOCKNUT, 7/16 STRAIGHT PIPE THREAD
11	2	24008	SEAL, DISPENSE TUBE, 7/16"DIA
12	2	31052	LOCKNUT, 7/16", DISPENSE TUBE SEAL, KEEPER
13	1	31116	LOCKNUT 1/8"-27 NPT
14	1	83041	WASHER, .812"OD X .412"ID, FLAT
15	1	31005	FITTING, 90 DEG. ELBOW, 1/4 HOSE ID X 1/8 MPT
16	1	23249	LOCKNUT 1/4"-18 NPT MODIFIED THREAD
17	1	83042	WASHER, .875"OD X .562"ID, FLAT
18	1	25098	FITTING, COMPRESSION MALE CONNECTOR
19	3	03332	BRACKET 2, ONE SHOT THERMOSTAT
20	3	53088	THERMOSTAT, SINGLE SHOT, 240V/40A
21	6	83011	WASHER, #6 SCREW SIZE, INTERNAL
22	6	84045	NUT, HEX 6-32, UNDERSIZED
23	3	108071	ASSEMBLY, RELAY, SOLID STATE, 50 A/ 600V
24	6	15013	STANDOFF, 6-32 x1.25 LG., 1/4 HEX WIDTH
25	2	24002	O-RING, TANK COVER
26	2	102013	ASSEMBLY, TANK COVER
27	3 or 6	107002	ASSEMBLY, IMMERSION HEATER, 3000W, 240VAC
27	3 or 6	107003	ASSEMBLY, IMMERSION HEATER, 4000W, 240VAC
28	3	03443	ALUMINUM BRACKET FOR SSR

For tank assembly and wiring diagram part numbers, call Tech Support at 800-338-2699. Provide the brewer serial number when calling.

Troubleshooting

Brewing Problem	Possible Cause	Solution
Brew handle will not stay down	Power switch off.	-Turn switch on.
	No power to the brewer (Brewer lights are not illuminated)	-Make sure the brewer is plugged in. -Check the wall circuit breaker / reset -Turn the brewer power switch off then back on (it has an internal breaker)
	Bad timer or dispense latch assembly. (Brew light does not come on and handle won't stay down)	-Check for voltage reaching the timer from the dispense latch assembly if yes replace timer. If no, replace latch assy.
	Bad dispense latch assy. (Brew light does come on and handle won't stay down)	-Replace the dispense latch assembly
	Bad dispense latch assembly (brewer buzzes when in brew cycle)	-Replace the dispense latch assembly
Brew handle stays down but no water is dispensed	No water reaching the brewer	-Make sure the shut off valve is open. -Check water line for kinks; replace line if necessary -Check to see if filter is clogged by changing it.
Short brew levels EVERY BREW (One or Both sides are affected and levels are consistent)	Flow discs in spray heads in upside down	-Reassemble spray heads - bumps on spray cutter face ↓ with flange on flow disc facing ↓
	Water filter clogged	(See details in next section)
	Spray head clogged	-Clean and or replace the sprayhead
	Timer/s are set too low	-Advance timers to proper level.
	Incoming Voltage is too low for timers to function at proper time sequences	-Reset wall circuit breaker as one side may drop out & not flag the breaker. -Call an electrician to find loose connections in the building
Short brew levels SOME BREWS (One or Both sides are affected and levels are erratic)	Water filter clogged. (problem is worse during simultaneous brews)	-Replace water filter
	Weak dispense latch assembly (usually buzzes during cycle)	-Replace dispense latch assembly.
	Water pressure or flow rate is too low or fluctuates too much to support a full brew. (problem is worse in simultaneous brews)	-Make sure brewer has a dedicated water line -Ensure that the shut off valve is open all the way (Never use needle saddle valves) -Increase the diameter of the water line to the brewer and or find stable source.
Brew Time required to fill LUXUS are not the same for both sides	Brewer is not level	-With an accurate level, level the brewer front to back and left to right by adjusting the feet.
High brew levels EVERY BREW (overfills but does stop) SOME BREWS	Timer/s are set too high	-Adjust timers down to appropriate level
	Thermal server not empty	-Empty the server and try again
Brew basket or filter overflows		-Call FETCO Service Dept. to discuss. (800) 338-2699
Weak Coffee	Spray head missing	-Attach spray head assembly.
	Improper dose	-Measure and confirm correct dose
	Filter papers	-Make sure only one paper is used
	Cracked dispense tube	-See "spray head drips MAJOR", below
	Low brew temperature (Temperature inside the hot water tank is set to 205° F, the metal delivery system drops the temp.)	-Adjust thermostat so the water stream measured at the bottom of the brew basket, 1/3 of the way through the brew cycle, equals 190 degrees + or - 5 degrees
Grounds not saturated	Spray head missing	-Replace spray head
	Half batch used incorrectly	-Use smaller "half batch" brew basket -Discourage half batch use -Investigate the need for a smaller brewer
	Water Softener in use	-Move brewer water feed to a non-softened source.
	Degassing - extremely fresh coffee	-Call FETCO Service Dept. to discuss. (800) 338-2699
No bypass EVERY BREW → SOME BREWS →	Bypass valve closed	-Open bypass valve
	Flow disc wrong size or missing	-Correct or replace flow disc
Spray head / brew basket drips either side or both MINOR	Condensation around the sprayhead area	-Wipe sprayhead area after brewing; place an empty container under brew cone when not in use.
	Condensation from water tank dripping through dispense tube	-Insert an empty brew basket and server under brew heads when not in use

Brewing Problem	Possible Cause	Solution
Spray head / brew basket drips either side or both MAJOR	Cracked dispense tube/s (This problem starts out minor but gets steadily worse)	-Replace both dispense tubes even if other side is not dripping
	Fill valve not sealing (Will drip even with power off.)	-See next section - "Brewer won't stop brewing", "Bad or stuck fill valve".
Brewer won't stop brewing (not same as high brew levels)	Dispense tube cracked	-See "sprayhead drips MAJOR" above
	Mechanical binding (brew handle stays down / brew light turns off at normal time)	-Re-align the brew handle / brass sprayhead tower / and dispense tube into a straight line by moving brass tower
	Water pressure over 75psi	-Place a water pressure regulator on the line and reduce to 20-75 psi
	Dispense tube drive screw off. A 2.5" screw that connects the handle to the dispense tube at the brass sprayhead tower. (handle returns up and brew lamp turns off but brewing continues)	-Ensure that the drive screw is straight (can be straightened by hand while still in the brew handle) and reconnect to the dispense tube. The flange that the drive screw engages MUST be held flat against the brass sprayhead tower, without being able to back out.
	Water level probe bad or encrusted with lime. (causes brewer to continue filling hot water tank which will overflow into the brew baskets)	-Clean lime build up on the probe tip and/or tank wall. (Holding the probe wire (green) from the probe end to the body of the brewer should stop the fill if the probe is bad but the liquid level board is good)
	Bad liquid level control board	-Replace the LLC board if grounding the probe end of the (green) probe wire to the body of brewer does not remove the voltage at the fill terminal on the LLC board.
	Bad or stuck fill valve	-Rebuild or replace the fill valve if no voltage is on the coil (it is not magnetic) and it still passes water to the tank. (Disconnect the outlet side to see if it leaks water to the tank)
Coffee tastes too strong	Incorrect dosage	-Measure and confirm the correct amount of coffee required
	Short brew levels	-See "Short brew levels", above.

Temperature Problem (brewer only)	Possible Cause	Solution
See also LUXUS problems		
Brew water is cold / not hot enough, ready light is OFF. (Before proceeding, make sure water tank refills when water is dispensed. The brewer will not heat unless the tank is full.)	No power to brewer.	-Make sure power switch is on. -Reset machine circuit breaker. -Check power connection. (plug or hard wire connection). -Check building circuit breaker. (Always reset breaker by switching off, then on.)
	Defective liquid level control board. (No power to thermostat).	-With power on, and water tank full, check LLC board for 120 volts on brown wire and neutral. Replace LLC board if there is no voltage.
	Bad connections on solid state relay. (No power to heaters).	-Check relay for burned or loose connections. Replace with high temperature connectors if necessary.
	Defective solid state relay. (No power to heaters).	-Check input and output voltages on relay. 120 volts on blue wire (input) but no voltage out to heaters indicates a bad relay.
	Bad heating element/s.	-Check amperage draw on heater wires. 0 amps = bad heater.
Brew water is cold / not hot enough, ready light is ON.	Bad Thermostat (the thermostat believes that it is at set temperature)	-Replace the thermostat and or thermal probe. It's not possible to trouble shoot the probe.
	Low brew temperature setting on thermostat	-See "Low brew temperature" under "Weak Coffee" section.
Slow to recover temperature (Ready light takes along time to come back on after brewing.)	Brewers with more than one heater can have just one fail	-Check amperage draw on heater wires. 0 amps = bad heater.
	Hot water tank limed up	-Remove access cover to the hot water tank and inspect for lime. Remove the brewer for shop de-liming if build up is thick.
Boiling	Thermostat set too high for altitude (Denver etc.)	-Reduce temperature setting to 3 degrees below boiling at your altitude
	Defective thermostat	-Replace the thermostat and or thermal probe. It's not possible to trouble shoot the probe.

LUXUS TPD-1.5 Problem	Possible Cause	Solution
LUXUS leaking from the base	Overflow of coffee, or water from cleaning running down the side and collecting in the black plastic base (1.5 gallon LUXUS only)	-Remove the plastic base (it slips on and off) wipe the interior and plastic base dry and reassemble. Monitor brew practices & do not clean containers in sinks or dishwashers
	Bad O-ring gasket behind faucet shank (1.5 & 3 gallon LUXUS)	-Remove the faucet, then unbolt the faucet shank from the LUXUS and replace the O-ring.
LUXUS leaking from sight gauge	Brew level set too high	-Adjust timers for proper level
	Sight gauge cap not tight	-Tighten gauge cap (show operators how this could have been loosened when the vent cap was opened)
	Lower gasket missing or bad	-Replace and or discourage casual cleaning practices
Coffee not hot enough	LUXUS not preheated before first brew of the day	-Preheat the LUXUS 1/2 full with hot water and let stand for 15 minutes
	Attempting to hold coffee too long.	-Review discard times
	Using 1/2 batch on regular basis	-Encourage full batch use except at end of day or shift. Explore the need for smaller brewers
	Judging temperature from a sample that is too small, taken from an infrequently used LUXUS	-A small amount of coffee in the faucet body will cool in about 15 minutes.
Drip from faucet	Blockage in faucet (hair from cleaning brush, coffee oils, etc.)	-Remove faucet bonnet (top part with handle attached) and clean seat cup and faucet body. Clean on regular basis
	Faucet seat cup	-Remove faucet bonnet (top part with handle attached) and replace seat cup. Stained cups are OK cracked or brittle are not.
Coffee won't dispense	Vents closed on top of gauge tube and or twist lock cover	-Open vents (vents are closed only for transporting the servers or to extend holding times prior to serving coffee)

