

# Ice•Devlce™ Ice Management Systems

Order parts online  
[www.follettice.com](http://www.follettice.com)

## Installation, Operation & Parts Manual



Ice•Devlce with SmartCART™ 75



# Contents

<b>Welcome to Follett</b> .....	<b>4</b>
Before you begin .....	4
<b>Product descriptions</b> .....	<b>4</b>
<b>Installation</b> .....	<b>6</b>
A. Removing lower door assembly (if needed) .....	6
B. Reinstalling door assembly .....	6
C. Installing base section .....	7
D. Installing single section bin .....	7
E. Installing two-section bins .....	7
F. Installing bin section .....	8
G. Installing 8" (204mm) plastic chute .....	9
H. Installing 4" (102mm) plastic chute .....	9
I. Installing icemaker drain .....	9
J. Installing icemaker tie-downs .....	9
K. Final connections (for all models) .....	9
<b>Bin operation</b> .....	<b>10</b>
General operation of unit .....	10
Adjusting SmartGATE .....	10
Using tools .....	11
<b>Cleaning Ice•Devlce</b> .....	<b>11</b>
Exterior care .....	11
Interior care .....	11
<b>Technical assistance available toll free</b> .....	<b>11</b>
<b>Assembly, operation and cleaning of Ice•Devlce carts and accessories</b> .....	<b>12</b>
SmartCART 75 .....	12
SmartCART 125 .....	14
Cambro ICS125L Cart .....	15
Bagger Accessory .....	16
Totes ice carrier for low-profile Ice•Devlce unit .....	17
<b>Replacement parts</b> .....	<b>18</b>
Bin replacement parts .....	18
Bin door replacement parts .....	19
COR accessory package replacement parts – Ice•Devlce with elevated base for correctional facilities .....	20
SmartCART 75 replacement parts (stainless drain tray base) .....	20
New SmartCART 75 replacement parts (roto-molded drain tray base) .....	21
SmartCART 125 and Cambro ICS125 replacement parts .....	21
Manual bagger replacement parts .....	22

## Welcome to Follett

Follett ice storage bins enjoy a well-deserved reputation for excellent performance, long-term reliability and outstanding labor-saving and sanitation benefits. To ensure that your ice management system delivers this same degree of service, please read this manual carefully before installing or operating the system. If you have any questions or require technical help at any point, please call our technical service group at (877) 612-5086, or +1 (610) 252-7301.

### Before you begin

After uncrating, remove all packing material and inspect the ice management system and accessories for shipping damage. If damage is found, notify the shipper immediately and contact Follett so that we can help in the filing of a claim, if necessary.

### Product descriptions

Check your paperwork and enclosed accessories to determine which ice management system you have. Follett numbers are designed to provide information about the type and capacity of Follett products. Following is an explanation of the different variations in the Ice•Device Ice Management Systems series.

## DEV1010SG-48-75

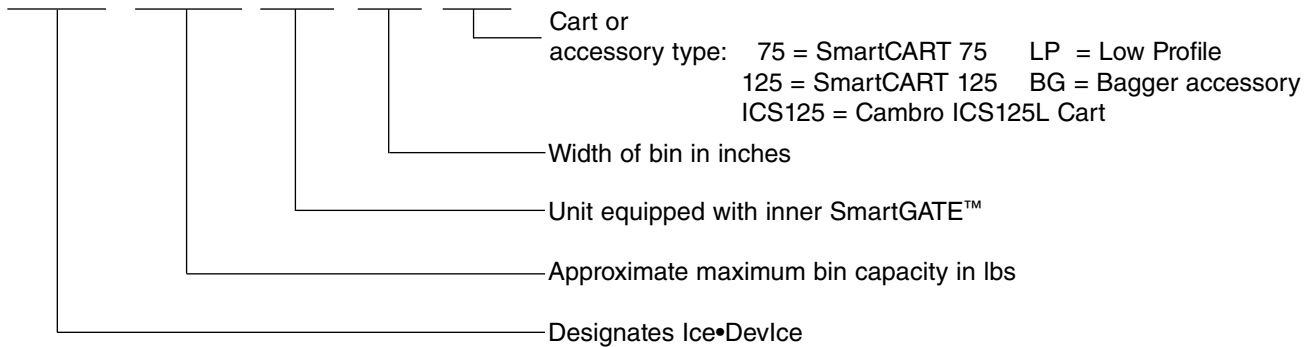

Verify that all parts have been shipped. You should have received the following:

#### **DEV\_\_\_\_\_SG-\_\_\_\_-BG** **Ice•Device with**

##### **bagger accessory:**

- Ice storage bin
- 24" (610mm) high base
- 4" (102mm) plastic ice chute
- Bagger accessory kit
- Ice probe and rake tools

#### **DEV\_\_\_\_\_SG-\_\_\_\_-LP** **Low-profile Ice•Device**

- Ice storage bin
- 10" (254mm) legs
- 4" (102mm) plastic ice chute
- 1 Totes ice carrier
- Ice probe and rake tools

#### **DEV\_\_\_\_\_SG-\_\_\_\_\_** **Ice•Device for correctional** **facilities with accessory** **#00917054**

- Ice storage bin
- 37" (940mm) high base
- 8" (204mm) plastic ice chute
- Ice probe and rake tools



DEV \_\_\_\_\_ SG-\_\_-75

**Ice•Devlce with SmartCART 75:**

- Ice storage bin
- 24" (610mm) high base
- 8" (203mm) plastic ice chute
- Ice cart with three Totes ice carriers
- Ice probe and rake tools



DEV \_\_\_\_\_ SG-\_\_-125

**Ice•Devlce with SmartCART 125:**

- Ice storage bin
- 24" (610mm) high base
- 4" (102mm) plastic ice chute
- Insulated plastic ice transport cart with hinged lid
- Ice probe and rake tools



DEV \_\_\_\_\_ SG-\_\_-ICS125

**Ice•Devlce with Cambro ICS125L:**

- Ice storage bin
- 24" (610mm) high base
- 4" (102mm) plastic ice chute
- Insulated plastic ice transport cart with hinged lid
- Ice probe and rake tools

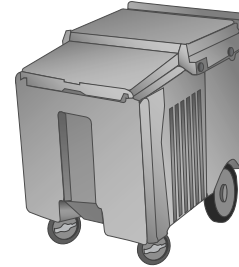

**Important cautions and operating rules**

**Read this manual completely before assembling or operating the ice management system and follow cautions and instructions listed below.**

**To avoid damage to ice management system and injury during operation:**

- Top is **NOT** fastened to bin
- Do not move ice management system once icemaker has been installed
- Anchor flanged feet to floor as instructed
- Base section must be bracketed to wall
- Use only tools provided to assist ice flow
- Use cart only to transport ice

**To avoid injury during operation of unit:**

- Keep entire body clear of bin when breaking up ice
- Keep head and face away from tools when breaking up ice
- Keep floor around bin free of ice and water
- Always operate cart at a slow, reasonable speed

**For best operation and to ensure delivery of clean, sanitary ice:**

- Be sure bin is level in both directions to provide proper drainage
- Position cart, Totes ice carrier or bagger below chute before operating chute door
- Install a charcoal water filter on inlet water for icemaker
- Hang tools in supplied bracket after each use
- Keep tools clean and in good repair to avoid ice contamination
- Follow instructions in this manual for proper cleaning and maintenance

## Installation

If unit does not fit through door, lower door assembly can be removed (see steps A and B below). If door removal is not necessary, proceed to step C.

### A. Removing lower door assembly (if needed)

1. With lower access door closed remove Phillips head screw and washer from hinge on each side of lower access door.
2. Insert screwdriver between door and hinge bracket on one side of door and gently push against bracket to provide room for door stud to clear bracket.
3. Remove access door.
4. Disengage stop latch on right side of SmartGATE™ and pull up on gate to remove.
5. Remove 4 screws (3 screws for 27" (686mm) snout) on hood above door assembly.
6. Pull forward on assembly to remove.

### B. Reinstalling door assembly

1. Reinstall lower door assembly in bin opening. (Do not disturb gasket around opening.)
2. Reinstall four (4) screws (3 screws for 27" (686mm) snout) in hood at top of door assembly.
3. Reinstall SmartGATE in side panel tracks and push down to seat.
4. With door closed insert one door stud through hinge bracket, install washer, screw and tighten.  
**Note:** For proper operation the access door must be reinstalled in the closed position.
5. On other side, insert screwdriver between door and hinge bracket and gently push against bracket to provide room for door stud to clear bracket.
6. Reinstall washer and screw in lift door and tighten.
7. Check door to ensure proper operation.

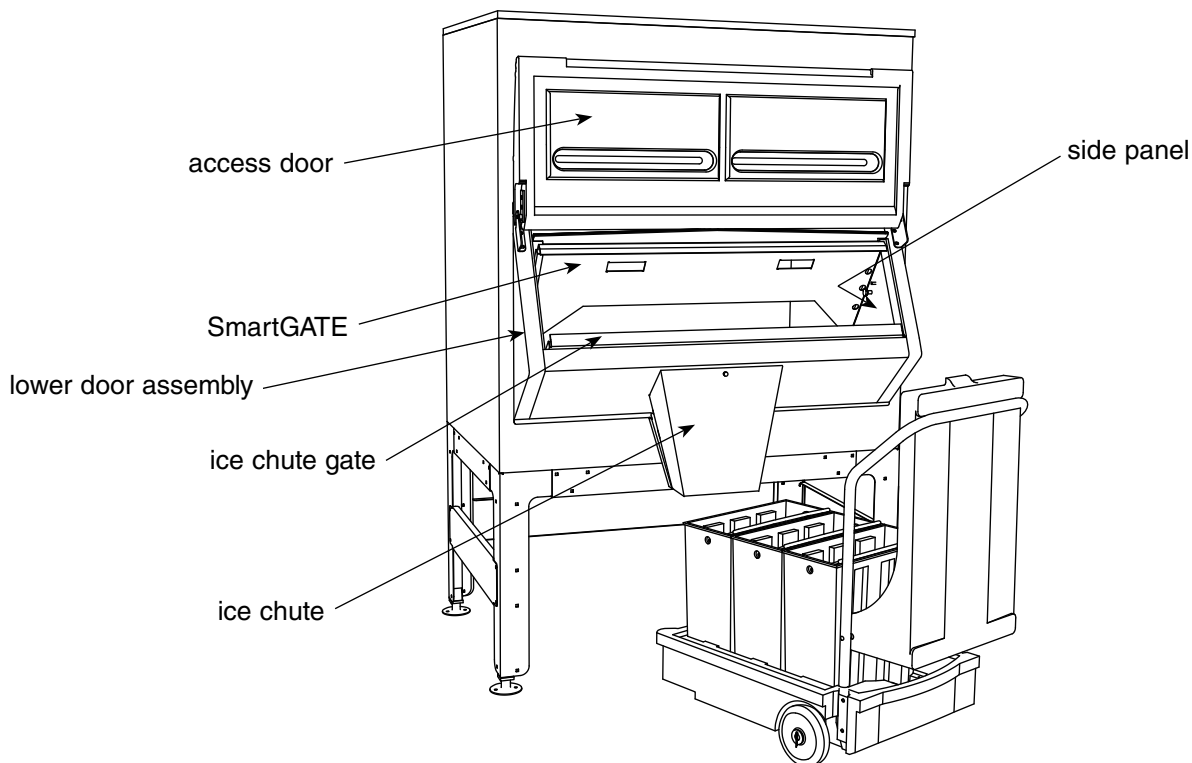

### C. Installing base section

(Ice•Device models with SmartCART 75, 125, Cambro\* ICS125, bagger accessory or correctional package)

1. Remove screws holding base to skid and remove skid.
2. Position base in intended position and adjust feet to level in both directions.
3. **For models with SmartCART 75:** Adjust feet and level base so that there is no interference between base and cart when cart is rolled under base with lid closed.
4. Mark position of each flanged foot anchoring hole.
5. Move base section out of the way and install anchors for 1/4" bolts in floor (supplied by others).
6. Reposition unit in its intended position.
7. Anchor base unit to floor through flanged feet.
8. Anchor base to wall using brackets and fasteners (supplied by others).
9. Use holes in side of base section to connect brackets.
10. Mark hole locations on wall.
11. Drill holes if needed.
12. Fasten brackets to base and wall.

### D. Installing single section bin

(for Ice•Device models with SmartCART 75, 125, Cambro ICS125 or bagger accessory)

1. Remove all packaging material from bin.
2. Remove any accessories packed inside bin.
3. Remove top from bin.
4. Lay bin on its back being careful to protect finish, and remove bolts holding skid to bin.
5. Install bin section on base.
6. Place supplied 1-3/4" washers on supplied bolts and install bolts up through base and into bin at each corner. **Do not use skid bolts.**
7. **For model DEV2250 only,** use supplied plugs to close bolt holes in bin back to prevent contamination of insulation.
8. Remove protective covering from exterior.
9. Reinstall top onto bin.
10. Use supplied screws with power driver to install tool bracket in holes on either side of Ice•Device.
11. Mount icemaker(s) on top of bin section in accordance with icemaker manufacturer's instructions.
12. For models COR base must be bracketed to wall.

### E. Installing two-section bins

(for Ice•Device models with SmartCART 75, 125, Cambro ICS125 or bagger accessory)

1. Remove all packing material from both sections of bin.
2. Remove any accessories packed inside lower section of bin.
3. Set lower section upright and remove bolts holding skid to back of bin.
4. To prevent contamination of insulation, use supplied plugs to close bolt holes in bin back.
5. Install bin on base.
6. Place supplied 1-3/4" washers on supplied bolts and install bolts up through base and into bin at each corner. **Do not use skid bolts.**
7. Remove protective covering from stainless steel surfaces.
8. Using provided caulking gun and one of two (2) 10 oz tubes of sealant provided, run a 1/8" (3mm) bead of silastic sealant over center of each band of gasketing on lower section, including over brackets (Fig.1).
9. Remove bolts holding skid to upper section back and close holes with supplied plugs.
10. Position upper section over lower section.

Fig. 1

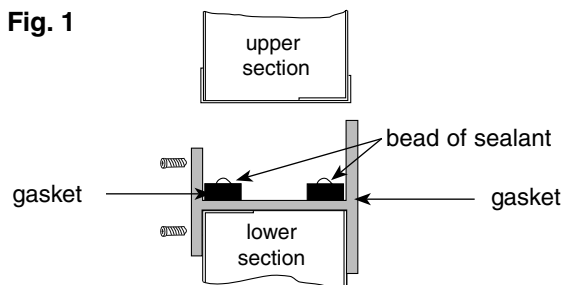

\* Cambro is a registered trademark of Cambro Manufacturing Company in the United States and other countries.



**Follow Steps 11 - 15 to anchor upper and lower sections of all two-section upright bins. Brackets must be installed to avoid possible injury should unit move.**

11. Lower upper section onto lower section, taking care not to disturb gasketing material and sealant beads.
12. Remove protective covering from stainless steel surfaces.
13. Install icemaker according to manufacturer's instructions.
14. From inside bin (access can be gained through lower door assembly) seal entire perimeter of seam between upper and lower sections with General Electric RTV 180 sealant provided (Figs. 2, 3).
15. Install supplied screws on side H-bracket and tighten, then seal entire perimeter of H-bracket with silastic.

**Fig. 2 – Cross Section, Side View**

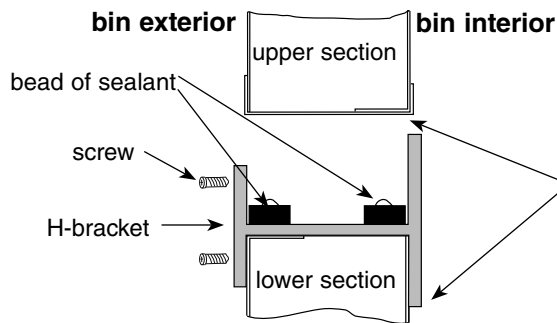

**Fig. 3 – Bin Cutaway**

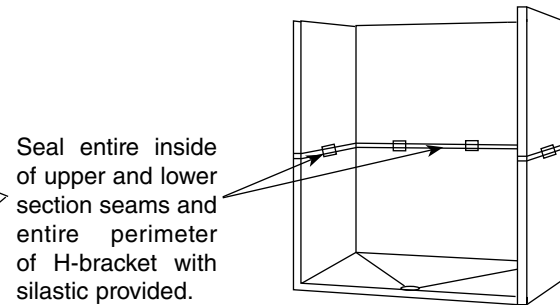

**Completely cover gasket material with sealant. Failure to properly seal sections may result in leakage and/or ice contamination, and will void warranty.**

16. Use supplied screws with a power driver to install tool bracket in holes on either side of Ice•Device.
17. Insert short side of inspection window through notch in upper and lower track and continue to rear groove. Repeat with second window only to front groove.
18. Remove any remaining protective covering or temporary fastenings from doors and outside of bin.

## **F. Installing bin section**

**(for low-profile Ice•Device models only)**

1. Remove all packing material from bin.
2. Remove set of four legs and any other accessories packed inside bin.
3. Remove top from bin.
4. Lay bin on its back being careful to protect finish and remove bolts holding skid to bin.
5. Screw legs into tapped holes in bin bottom and tighten to seat legs well against bottom.
6. Set bin upright.
7. Remove protective covering from exterior.
8. Move bin to permanent location.
9. Adjust "foot" at bottom of each leg to level bin in both directions.
10. Mark position of each flanged foot anchoring hole.
11. Move base section out of the way and install anchors for 1/4" bolts in floor (supplied by others).
12. Reposition unit in its intended position.
13. Anchor base unit to floor through flanged feet.
14. Mount ice maker.



## G. Installing 8" (204mm) plastic chute

(for Ice•Device models with SmartCART 75, COR package)

1. Orient stainless chute bracket with open end of bracket tabs facing down.
2. Insert supplied 1/2" 1/4-20 carriage head bolts through bracket and base and hand tighten only.
3. Gently push on sides of plastic chute to fit inside bracket, inserting bracket tabs into slots in plastic chute.
4. Push up on plastic chute to align holes and secure with supplied thumbscrew.
5. Tighten carriage bolts holding bracket.

Fig. 4

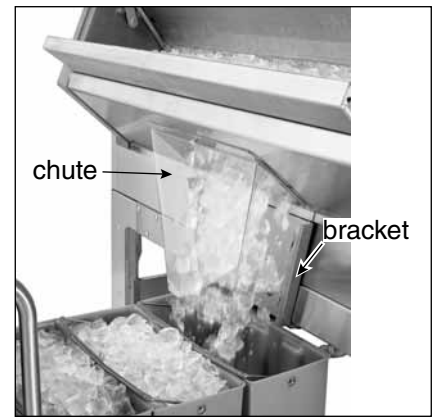

## H. Installing 4" (102mm) plastic chute

(for Ice•Device models with SmartCART 125, 240 or bagger accessory, and low-profile units)

1. Orient stainless steel chute bracket with open end of bracket tabs facing down.
2. Loosely fasten bracket with two thumbscrews provided through holes into lower door assembly.
3. Install plastic chute into bracket, making sure screw hole is oriented at top.
4. Align hole in chute and bracket with threaded hole in lower door assembly and fasten with thumbscrew.
5. Tighten all thumbscrews.

## I. Installing icemaker drain

Required for some icemakers only. For these machines Follett predrills hole and provides 3/4" straight threaded drain fitting to be installed through hole.

To install fitting:

1. Remove plastic nut on fitting.
2. From inside (liner side) bin, insert threaded portion through hole provided in side of bin.
3. Replace plastic nut on threaded portion and tighten against outside of bin.
4. Connect supplied tubing to icemaker drain connection after installing icemaker.

Fig. 5

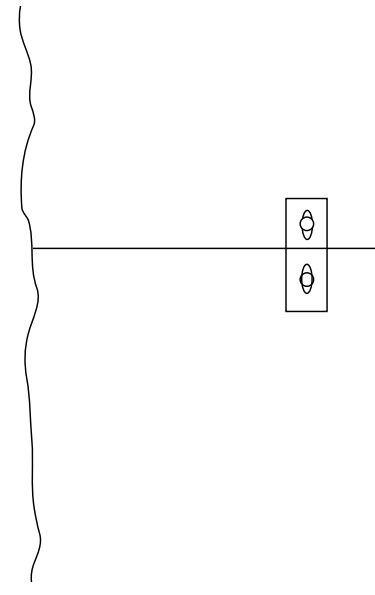

## J. Installing icemaker tie-downs

Required for some icemaker applications only. If this fitting is included with your bin, proceed as follows:

1. Align icemaker back flush with bin back.
2. Using center of vertical slot as template, drill through icemaker wall with a 15/64 drill.
3. Fasten straps to icemaker and bin (bin holes are predrilled) with #14 x 1/2 sheet metal screws and washers provided.

## K. Final connections (for all models)



**Avoid excessive tightening when connecting to this fitting.**

1. Install supplied 1" elbow into drain fitting under bin.
2. Connect customer supplied length of vinyl tube to barb end and route to either side or rear of bin (so not to interfere with cart movement).
3. Make final connections to icemaker.

# Bin operation

## General operation of unit

Ice in the hopper section of the ice management system falls through the ice chute in front of the bin and into the cart, Totes ice carrier or bag when the chute gate is pulled up. The flow of ice is stopped by pushing down on the chute gate. The SmartGATE restricts the flow of ice into the hopper area and can be adjusted and locked at one of several levels to accommodate the flow characteristics of different types of ice.

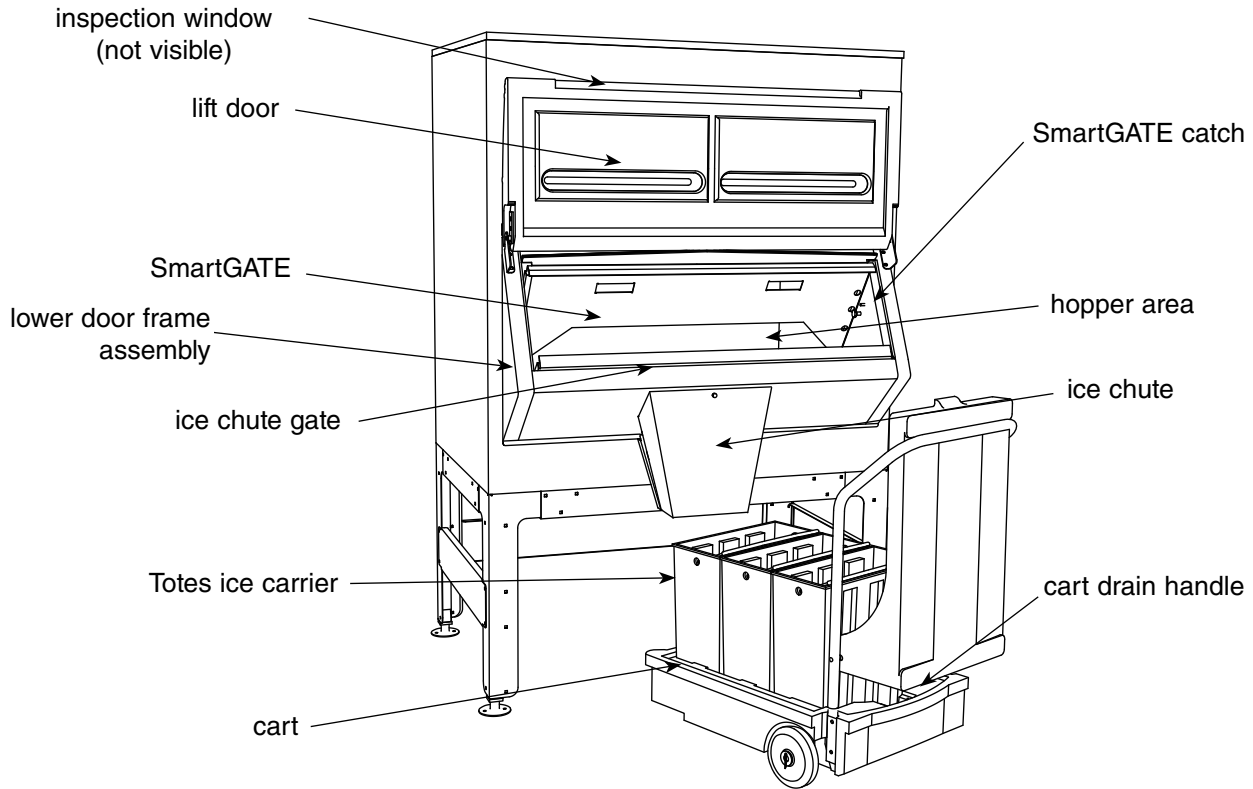

## Adjusting SmartGATE

The bin is shipped with the inner SmartGATE in the full down position, the best position for slippery cubes which flow well into the hopper through the cut-out in the bottom of the gate. For less slippery ices, the SmartGATE can be raised and locked in a higher position for better flow or when more access is needed.

1. Use full-length handle at top of SmartGATE to pull gate up. (Loose ice will cascade into hopper.)
2. If adequate ice has moved into hopper, push gate back down.
3. To lock gate at a higher level, pull up and hold gate at correct level (catch will automatically release when you pull up), and push tapered end of catch into nearest hole in gate.
4. To release catch, pull up on gate.

**Note:** SmartGATE and ice chute gate must both be in full down position before access door can be closed.

**Pull up on SmartGATE handle to adjust SmartGATE level**

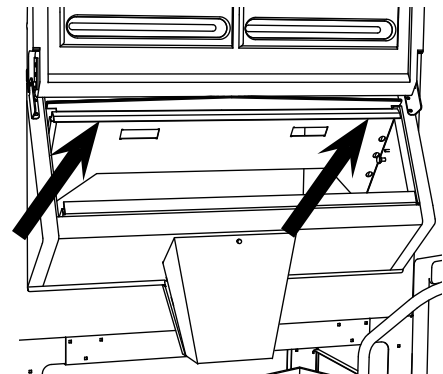

## Using tools

Two tools — a paddle and a rake — ship with the Ice•Devlce and should be mounted for easy access on either side of the bin in the bracket provided.

### Using paddle

If there is adequate ice in Ice•Devlce but hopper is not filled with ice, it may be that ice has congealed behind SmartGATE and cannot flow into hopper. This can often be remedied by simply opening and closing SmartGATE several times (see adjusting SmartGATE, above.) If problem continues, the paddle can be inserted through rectangular openings in SmartGATE and moved back and forth to break bridge.

### Using rake

When Ice•Devlce is almost empty of ice, there will not be enough ice piled in hopper area to allow chute to work. In this case, rake can be used to pull ice forward into hopper area.



**Use tools only as described. To avoid possible injury, keep head and face clear of hopper area and tools at all times. Do not use tools for other purposes.**

## Cleaning Ice•Devlce



**Interior of bin must be cleaned and sanitized prior to use. A regular schedule of cleaning maintenance is recommended following installation to ensure cleanliness of delivered ice.**

### Exterior care

The stainless steel exterior of the bin can be cleaned with a stainless cleaner such as 3M\* Stainless Steel Cleaner & Polish or equivalent.

### Interior care

The polyethylene liner should be cleaned and sanitized periodically with any product suitable for use in a food zone.

## Technical assistance available toll free

Should you have any questions concerning the installation or maintenance of Follett ice storage bins, please call our technical service department at (877) 612-5086 or +1 (610) 252-7301 between 8 a.m. and 5 p.m. Eastern time.

\* 3M is a trademark of 3M Company.

## Assembly, operation and cleaning of Ice•Devlce carts and accessories

The following assembly, operation and cleaning instructions have been divided into five parts. Use the section pertaining to the carts and accessories purchased with your Ice•Devlce unit.

### SmartCART 75

#### Assembly

1. Remove installation hardware from poly bag taped to Totes ice carrier.
2. Place cart handle ends along holes at the back of cart base. Align handle end holes with small holes in sides of cart.
3. Tighten bolts securely.
4. Position lid onto cart in between handles. From outside cart handle, insert 1.5" pivot pins through handle and lid bushings.
5. Push down on L-shaped cart drain handle and confirm that it seats in hole in cart bottom.
6. Arrange plastic Totes ice carriers in cart (longer dimension parallel with cart handle) and check that lid clears ice carriers when in down position.

#### Operation

1. A cart drain allows any melt water or cleaning solutions to be drained easily from cart. (Fig. 1)  
Each Totes ice carrier holds approximately 25lbs (11.34kg) of ice (Fig. 3).
2. The three-wheeled cart maneuvers easily in limited space, can be turned tightly and goes up and down different floor levels without difficulty (Fig. 2).
3. Molded base protect fixtures and walls.



**Use cart only for transport of ice. To avoid possible injury, do not ride in or on cart. Do not use cart to transport other items.**

**Fig. 1 – Drain**



Pull up on drain handle to open. Push down to close.

**Fig. 2 – Uneven flooring**



Tip cart onto back wheels to go up or down different floor levels.

**Fig. 3 – Lift ice carrier**



Lift Totes ice carrier straight up from cart and return to cart when empty.

### Filling Totes ice carriers

1. Lift lid. Position ice carrier closest to cart handle under ice chute.
2. Open lift door and confirm there is ample ice in hopper area. If not, see previous sections on adjusting SmartGATE and using tools.)
3. Pull chute gate up to start flow of ice into ice carrier.
4. When ice carrier is almost full, push chute gate down to stop flow. (Some ice will continue to fall as chute gate closes. Leave room in ice carrier for this in-flight ice to avoid spillage.)
5. Pull cart forward until next ice carrier is under chute and repeat steps 3 and 4.
6. Check that cart drain is closed and wheel cart to usage area.

**Note:** For better cart stability when removing Totes ice carriers: remove ice carrier closest to cart handle first, then proceed to middle ice carrier, ending with ice carrier farthest from cart handle.

Pull up on chute gate to allow ice to flow into ice carrier

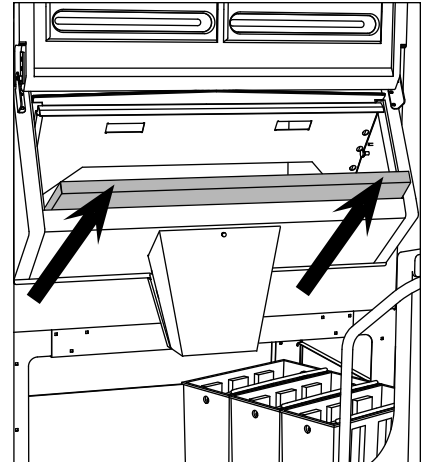

### Cleaning

The polyethylene Totes ice carrier should be cleaned and sanitized periodically with any product suitable for use in a food zone.



**The Totes ice carrier must be cleaned and sanitized prior to use. A regular schedule of cleaning maintenance is recommended following installation to ensure cleanliness of delivered ice. Do not run ice carrier through any dishwashing system.**

## SmartCART 125

### Assembly

The cart will arrive to you fully assembled. Check that the drip shelf inside the cart is horizontal, with the hole oriented toward the front.

### Operation

1. The cart is highly maneuverable with two swivel casters in front.
2. The polyethylene construction is resistant to damage from normal use, and prevents it from marring walls and fixtures.
3. A hand valve at the front of the cart allows melt water or cleaning solutions to be easily drained from the cart. The valve has a threaded fitting, allowing a hose to be connected, if desired.
4. The cart is capable of holding approximately 125 lbs (56.7kg) of ice.



### Filling cart

1. Open cart lid and position cart directly under ice chute.
2. Open lift door and confirm that there is enough ice in hopper area. (If not, see previous sections on “adjusting SmartGATE” and “using tools”)
3. Pull chute gate up to start flow of ice into cart.
4. When cart is almost full, push gate down to stop flow. (Some ice will continue to fall as chute gate closes. Leave room in cart for this in-flight ice to avoid spillage.)
5. Check that drain valve is closed.
6. Wheel cart to usage area. Lock caster before unloading

### Cleaning

1. The cart can be cleaned using a mild detergent and a soft brush, taking care not to mark the surface.
2. If stains appear, a mild cleaning compound can be used.
3. Periodic cleaning and sanitizing should be done with any product suitable for use in a food zone.
4. Remove and clean faucet regularly. Use a small brush to access faucet body and spout. Replace faucet properly to avoid leaks.



**Clean and sanitize cart interior prior to use and on regular schedule as needed thereafter to ensure cleanliness of delivered ice.**

## **Cambro ICS125L Cart Assembly**

The cart will arrive to you fully assembled. Check that the drip shelf inside the cart is horizontal, with the hole oriented toward the front.

### **Operation**

1. The cart is highly maneuverable with two swivel casters in front.
2. The polyethylene construction is resistant to damage from normal use, and prevents it from marring walls and fixtures.
3. A hand valve at the front of the cart allows melt water or cleaning solutions to be easily drained from the cart. The valve has a threaded fitting, allowing a hose to be connected, if desired.
4. The cart is capable of holding approximately 125 lbs (56.7kg) of ice.

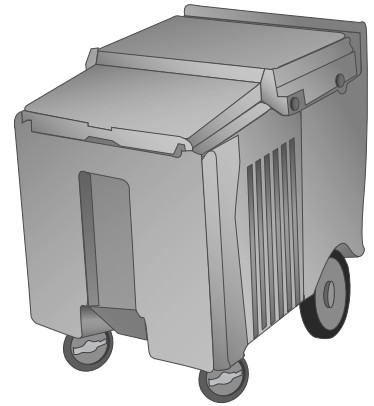

### **Filling cart**

1. Open cart lid and position cart directly under ice chute.
2. Open lift door and confirm that there is enough ice in hopper area. (If not, see previous sections on “adjusting SmartGATE” and “using tools”)
3. Pull chute gate up to start flow of ice into cart.
4. When cart is almost full, push gate down to stop flow. (Some ice will continue to fall as chute gate closes. Leave room in cart for this in-flight ice to avoid spillage.)
5. Check that drain valve is closed.
6. Wheel cart to usage area. Lock caster before unloading

### **Cleaning**

1. The cart can be cleaned using a mild detergent and a soft brush, taking care not to mark the surface.
2. If stains appear, a mild cleaning compound can be used.
3. Periodic cleaning and sanitizing should be done with any product suitable for use in a food zone.
4. Remove and clean faucet regularly. Use a small brush to access faucet body and spout. Replace faucet properly to avoid leaks.



**Clean and sanitize cart interior prior to use and on regular schedule as needed thereafter to ensure cleanliness of delivered ice.**

## Bagger Accessory Assembly

1. Attach tape dispenser to left side of bagger assembly for right-handed users using two screws provided. For left-handed users, attach to right side.
2. Center tape roll on tape drum Fig. 7, as shown, to dispense tape with adhesive side up.
3. Place tape drum with tape in slot Fig. 8 and pull tape lead end forward to front edge of bag sealer.

For ease of use, the bagger assembly can be attached to the bin using a Velcro strip that has been provided on the back of the bagger. Clean the front of the base under the chute of all dirt and oil, peel the backing off the Velcro strip to expose the adhesive, and press the bagger assembly against the base.

## Operation

1. The bagger accessory is used to fill 10 lb (4.65kg) bags of ice easily and with minimal spillage (optional 8 lb (363kg) bags are also available when reordering).
2. A “flag” type of seal, using the enclosed tape dispenser, is formed by a single strip of pressure-sensitive tape that encircles the neck of the bag.

## Filling bags with ice and sealing:

1. Position bagger assembly in front of bin below ice chute.
2. Hang wicket with bag on bracket behind white plastic funnel of bagger accessory.
3. Pull one bag open under white funnel.
4. Open bin door and pull up on ice chute gate to dispense ice.
5. Begin to close gate when bag is about half full.
6. To seal ice bag, twist neck of bag to be sealed and position at 90-degree angle over bag slot Fig 9., as shown.
7. Move bag neck downward to bottom of slot and pull sideways to remove sealed bag neck from bag sealer.

## Cleaning

1. The plastic funnel should be cleaned and sanitized periodically with any product suitable for use in a food zone.
2. The aluminum stand can be cleaned with mild detergent.

Fig. 6

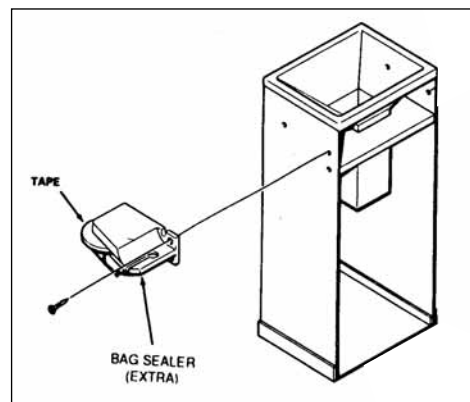

Fig. 7

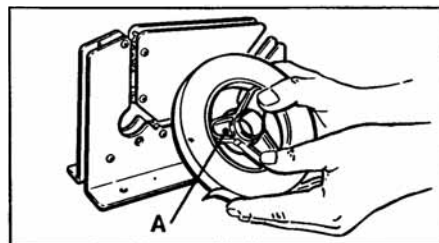

Fig. 8

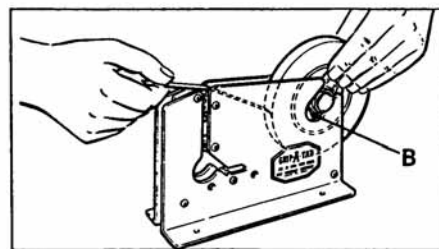
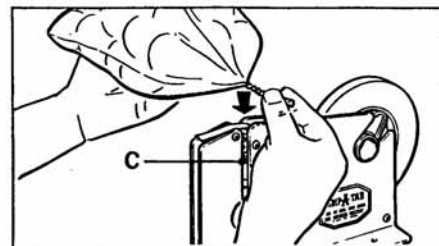

Fig. 9





## Totes ice carrier for low-profile Ice•DevIce unit Assembly

The Totes ice carrier requires no assembly.

### Operation

1. The polyethylene construction of the ice carrier makes it light and very resistant to damage from normal use.
2. The handle makes it convenient to transport up to 25 lbs (11.34kg) of ice and the shape of the ice carrier makes pouring easy.

### Filling Totes ice carrier

1. Position ice carrier under ice chute.
2. Open lift door and confirm there is enough ice in hopper area. (If not, see previous sections on “adjusting SmartGATE” and “using tools.”)
3. Pull ice chute gate up to start flow of ice into ice carrier.
4. When ice carrier is almost full, push chute gate down to stop flow. (Some ice will continue to fall as chute gate closes. Leave room in ice carrier for this in-flight ice to avoid spillage.)
5. Close lift door and carry ice carrier to usage area.

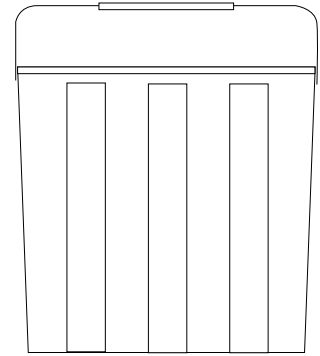

The polyethylene ice carrier should be cleaned and sanitized periodically with any product suitable for use in a food zone. **DO NOT RUN ICE CARRIER THROUGH A DISHWASHER.**

**Note:** If you purchased a SmartCART 75 for use with your low-profile Ice•DevIce, see pages 11 and 12 for assembly, operation and cleaning instructions.

# Replacement parts

## Bin replacement parts

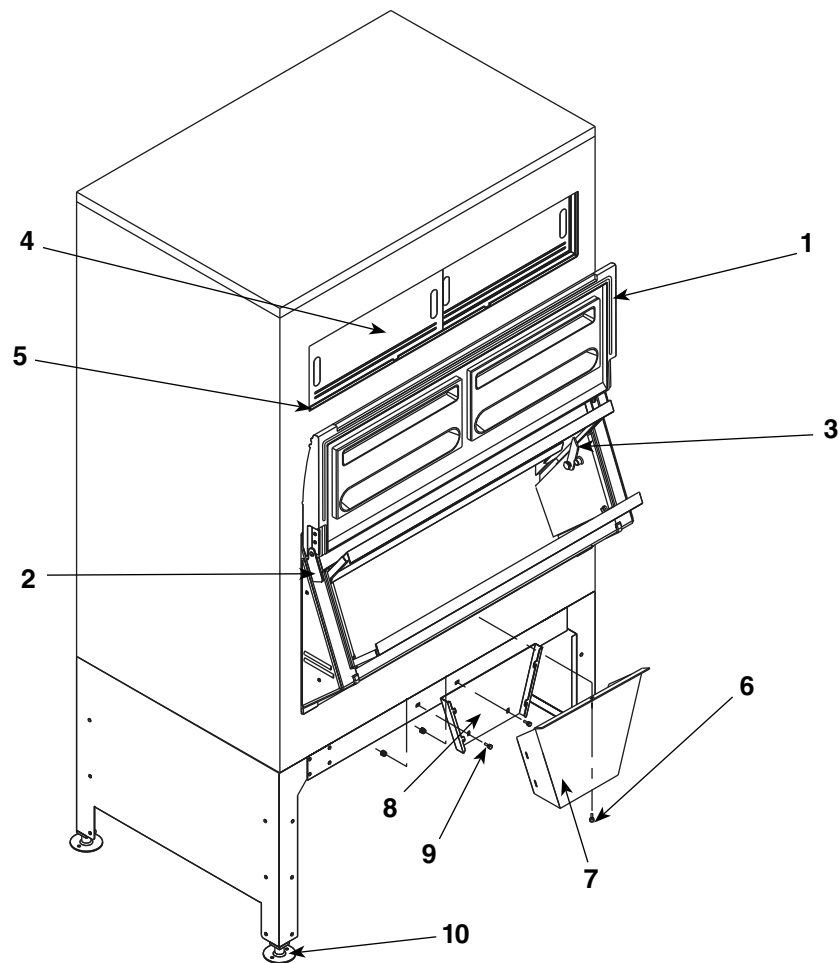

Part #	Description	Reference number
502176	Door, outer lift, 28" (686mm), (includes door hinges and hardware)	1
502177	Door, outer lift, 45" (1067mm), (includes door hinges and hardware)	1
502180	Hinges, pair (includes mounting hardware)	2
502218	Retainer, SmartGATE (includes shoulder screw)	3
502237	Inspection window 21.125" x 8.625" (537mm x 220mm)	4
502264	Inspection window 12.5" x 9" (318mm x 229mm)	4
501401	Track, inspection window (use with 502264 window)	5
501100	Thumbscrews, plastic chute	6
502373	Chute, plastic, long, 8" (204mm)	7
502554	Chute, plastic, short, 4" (102mm)	Not shown
502374	Chute bracket (includes hardware), long, 8" (204mm)	8
502555	Chute bracket (includes hardware), short, 4" (102mm)	Not shown
502281	Hardware, chute bracket, long, 8" (204mm)	9
502556	Hardware, chute bracket, short, 4" (102mm)	Not shown
502196	Flanged foot (one)	10
502639	Probe, ice, 36" (915mm)	Not shown
502952	Rake, ice, 36" (915mm)	Not shown
502872	Bracket, ice rake	Not shown
502557	Legs, 10" (254mm), low-profile (set of 4)	Not shown
502064	Bracket, hanging, ice probe	Not shown
00109538	Elbow, bottom drain	Not shown

## Bin door replacement parts

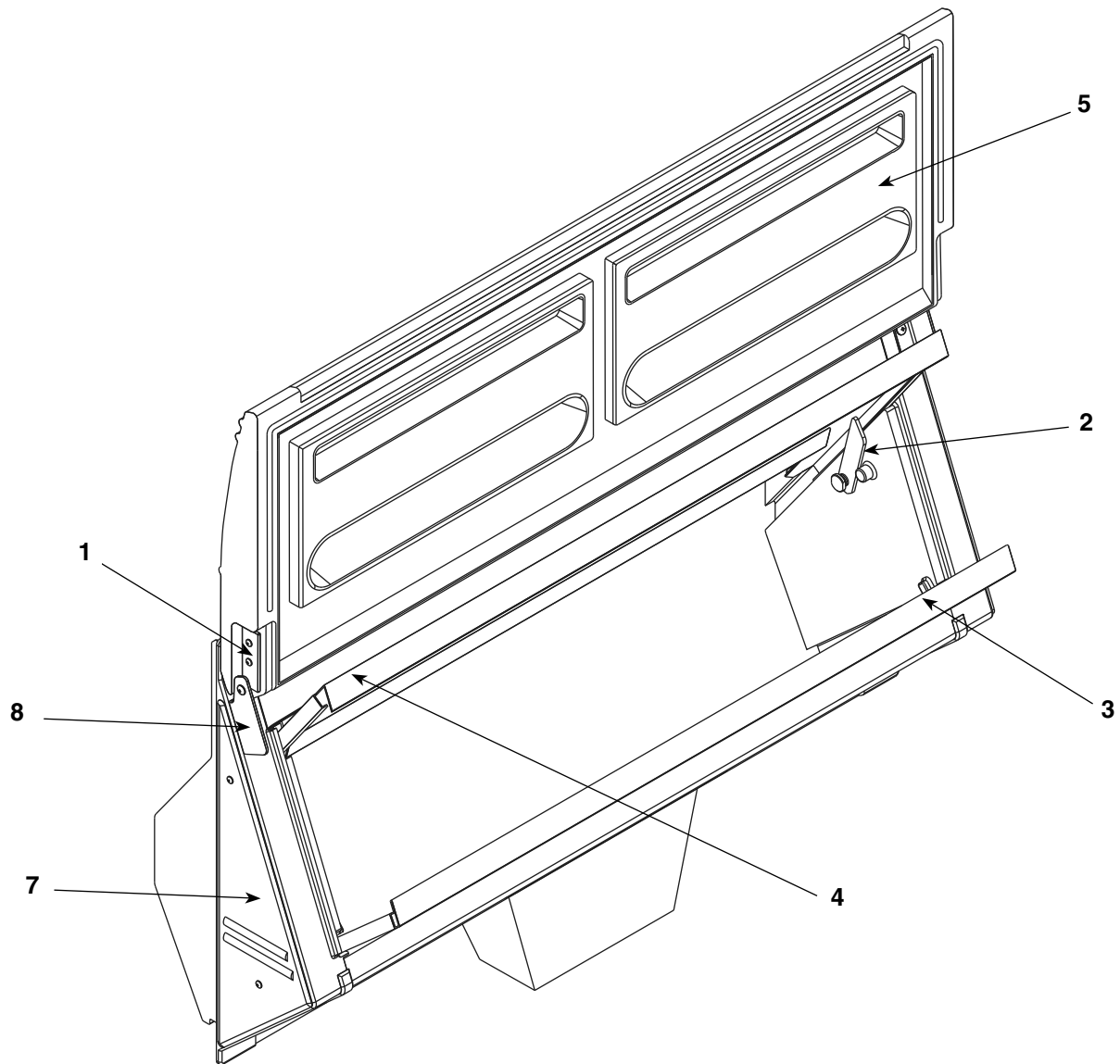

Part #	Description	Reference number
502178	Hinge assembly, left-hand (mounts to lift door)	1
502179	Hinge assembly, right-hand (mounts to lift door)	Not shown
502185	Locking catch, SmartGATE (includes shoulder screw)	2
00131649	Ice chute gate, 28" (712mm) wide door	3
00127506	Ice chute gate, 45" (1143mm) wide door	3
502367	SmartGATE, 28" (712mm) wide door	4
502363	SmartGATE, 45" (1143mm) wide door	4
502176	Lift door, 28" (712mm) wide (includes 502178 & 502179)	5
502177	Lift door, 45" (1143mm) wide (includes 502178 & 502179)	5
502371	Lower door frame assy (for use with 28" (712mm) door frame assembly)	7
502372	Lower door frame assy (for use with 45" (1143mm) door frame assembly)	7
502180	Hinges, pair (includes mounting hardware)	8

**COR accessory package replacement parts – Ice•Device with elevated base for correctional facilities**

Part #	Description	Reference number
00111377	45" poly door prison package	Not shown
00111385	28" poly door prison package	Not shown
00111393	Door, upper lock bracket (left and right set)	Not shown
00111401	End panel prison package (left and right set)	Not shown

**SmartCART 75 replacement parts (stainless drain tray base)**

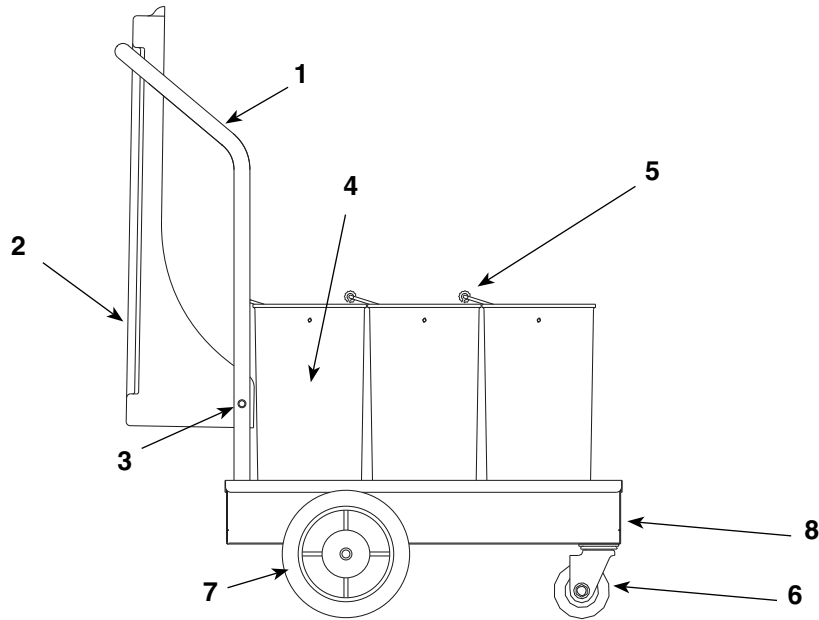

Part #	Description	Reference number
502197	Handle, cart	1
502198	Screws, cart handle mounting	Not shown
502203	Lid, cart (includes mounting hardware)	2
502204	Stud, pivot (1 pair), cart lid	3
502263	Totes ice carrier, non-draining (one)	4
502097	Handle, Totes ice carrier	5
502201	Wheel, front, cart	6
502200	Wheel, rear, cart	7
502572	Drain tray	8
502199	Bumper, cart (pair)	Not shown
502202	Drain assembly, cart	Not shown

## New SmartCART 75 replacement parts (roto-molded drain tray base)

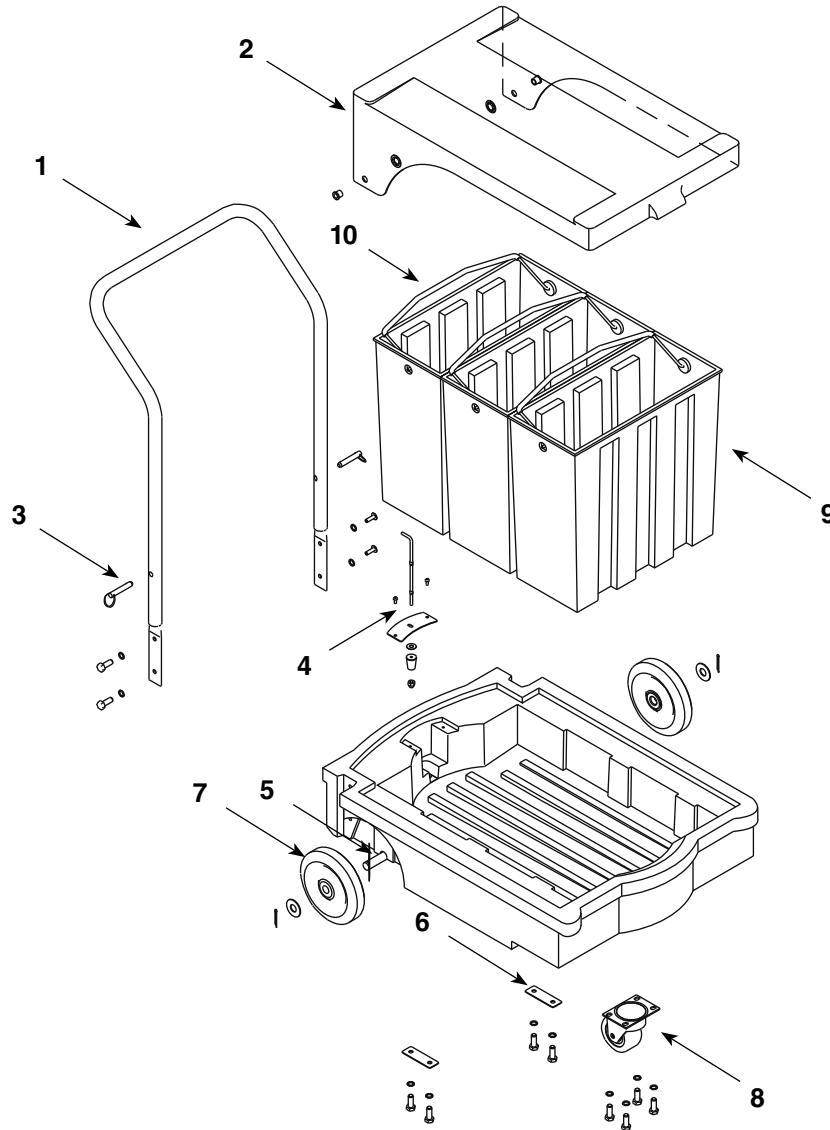

Part #	Description	Reference number
00115634	Handle with hardware	1
00115642	Lid with hardware	2
502204	Stud, pivot (1 pair), cart lid	3
00115659	Drain assembly, cart	4
00115667	Axle with cotter pins and washers	5
00115683	Plate, axle (2 required)	6
00134908	6" wheel with cotter pin and washer	7
502569	Wheel, front of cart	8
502263	Totes ice carrier, non draining (one)	9
502097	Handle, Totes ice carrier	10

## SmartCART 125 and Cambro ICS125 replacement parts

For replacement parts contact Follett technical service group, (877) 612-5086 or +1 (610) 252-7301.

## **Manual bagger replacement parts**

*For replacement parts, tape and bags contact:  
The Ice Box Company at (800) 632-3039.*



Ice•Device, SmartCART, SmartGATE, and Totes are trademarks of Follett Corporation.  
Chewblet and Follett are registered trademarks of Follett Corporation, registered in US.

---

**FOLLETT**  
*Innovative solutions, inspired by ice*

801 Church Lane • Easton, PA 18040, USA  
Toll free (877) 612-5086 • +1 (610) 252-7301  
[www.follettice.com](http://www.follettice.com)



207897R06  
02/11