

**Automatic load units with one ice machine**

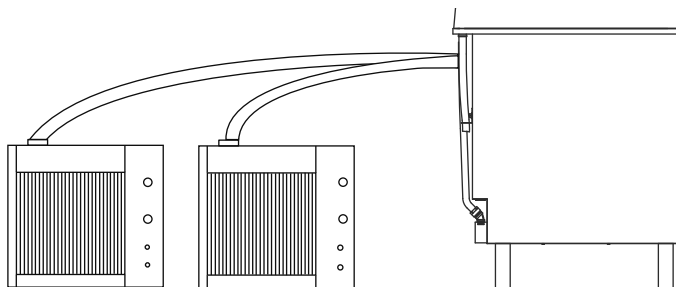

**Automatic load units with one ice machine**

**Following installation, please forward this manual  
to the appropriate operations person.**



# Contents

<b>Welcome to Follett</b> .....	<b>4</b>
Before you begin .....	4
<b>Important Safety Information</b> .....	<b>4</b>
<b>Specifications</b> .....	<b>5</b>
Electrical requirements .....	5
Plumbing .....	5
Clearance and access information .....	5
Field wiring diagrams .....	6
<b>Installation</b> .....	<b>7</b>
Installing EU155N dispenser in counter .....	7
<b>Installing remote ice machine (automatic load units only)</b> .....	<b>8</b>
<b>To start up and operate dispenser</b> .....	<b>9</b>
<b>User information</b> .....	<b>9</b>
How the dispenser works .....	9
<b>Cleaning and sanitizing procedures</b> .....	<b>9</b>
Cleaning bin before use .....	10
Periodic cleaning of dispenser .....	10
Quarterly cleaning of ice machine system .....	10
Disassembly instructions for periodic cleaning .....	11
<b>Service</b> .....	<b>12</b>
Dispense wheel motor removal (Fig. 3) .....	12
Before calling for service .....	14
Dispenser troubleshooting guide .....	14
<b>Replacement parts</b> .....	<b>15</b>
Dispenser exterior .....	15
Dispense assembly – side view .....	16
Hopper – side view .....	17
Auger motor .....	18
Electrical components .....	19

## Welcome to Follett

---

Follett ice and water dispensers enjoy a well-deserved reputation for excellent performance, long-term reliability and outstanding after-the-sale support. To ensure that this dispenser delivers that same degree of service, we ask that you take a moment to review this manual before beginning the installation of the dispenser. Should you have any questions or require technical help at any point, please call our technical service group at (610) 252-7301.

### Before you begin

- After uncrating and removing all packing material, inspect the equipment for concealed shipping damage. If damage is found, notify the shipper immediately and contact Follett Corporation so that we can help in the filing of a claim, if necessary.
- Check your paperwork to determine which model you have. Follett model numbers are designed to provide information about the type and capacity of Follett ice dispensing equipment. Following is an explanation of the different model numbers in the U155 Series.

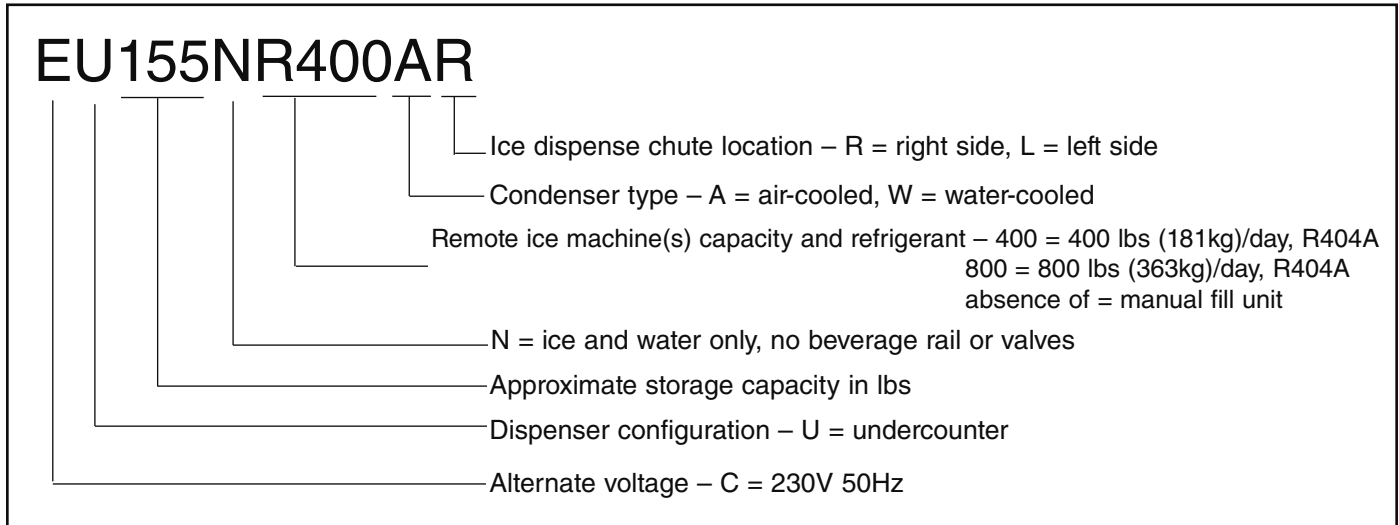

## Important Safety Information

---

Please read and adhere to the following safety information while installing, using, or servicing your Follett 7 Series Ice Dispenser.

1. Always disconnect power before servicing the dispenser.
2. Ice is slippery. Maintain counters and floors around dispenser in a clean and ice-free condition.
3. Ice is food. Follow the recommended cleaning and sanitizing instructions to maintain cleanliness of delivered ice.
4. Follett manual load dispensers can accommodate most cube/cubelet ices up to 1" square, or Follett compressed nugget ice. Crushed, flake, bagged, nugget or congealed ice cannot be used. Use of these ices can jam dispenser and void warranty. Separate any "waffle-like" sections of cubes before adding to dispenser. For ice compatibility questions, please call Follett customer service at (877) 612-5086 or +1 (610) 252-7301.
5. Follett recommends use of an activated carbon filter for units equipped with ice machines.
6. Storage area of dispenser contains mechanical, moving parts. Keep hands and arms clear of this area at all times. If access to this area is required, power to unit must be disconnected first.

# Specifications

## Electrical requirements

- Each ice machine and dispenser requires separate circuit with electrical disconnect within 6m. Equipment ground required.
- 230V, 50 Hz, 2A

## Plumbing

### Dispenser

- 3/4" PVC slip joint for hopper drain
- 3/4" PVC pipe nipple for beverage drain pan
- 3/8" ID red line tubing for water in
- Drains should be hard piped and insulated. Maintain at least 6 mm per 304 mm (1/4" per 12 in.) run slope on drain line run

### Ice machine

- Refer to Ice machine Installation Manual packed with ice machine for installation instructions

## Clearance and access information

- 1296mm above counter
- 305mm on side opposite tower, below counter
- Counter front or rear panel must be removable for service access to both sides of dispenser and ice machine(s), if any
- Below counter access to drain clean-out required on utility side of dispenser
- See Ice machine Installation Manual packed with ice machine(s) for clearance requirements for automatic load dispensers

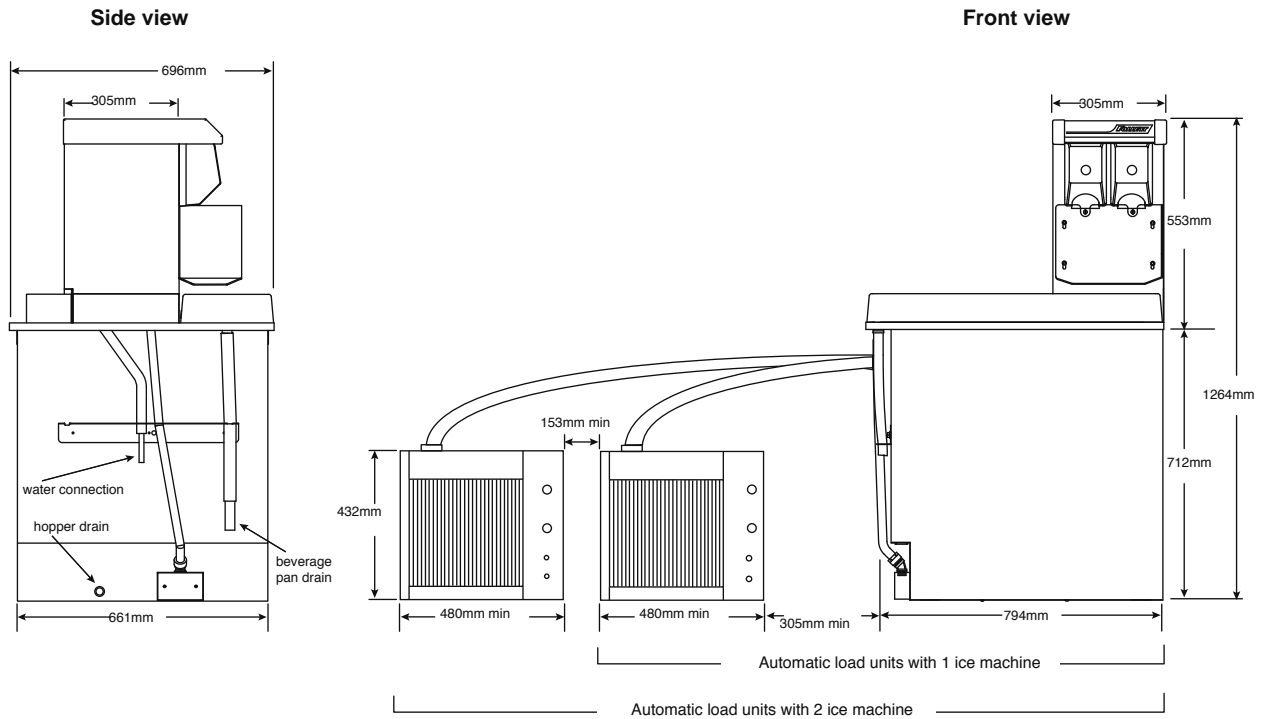

## Field wiring diagrams

### Automatic load units

One 230V, 50 Hz circuit is required. The field wiring diagram is intended to aid the electrician or technician in understanding how the equipment works.

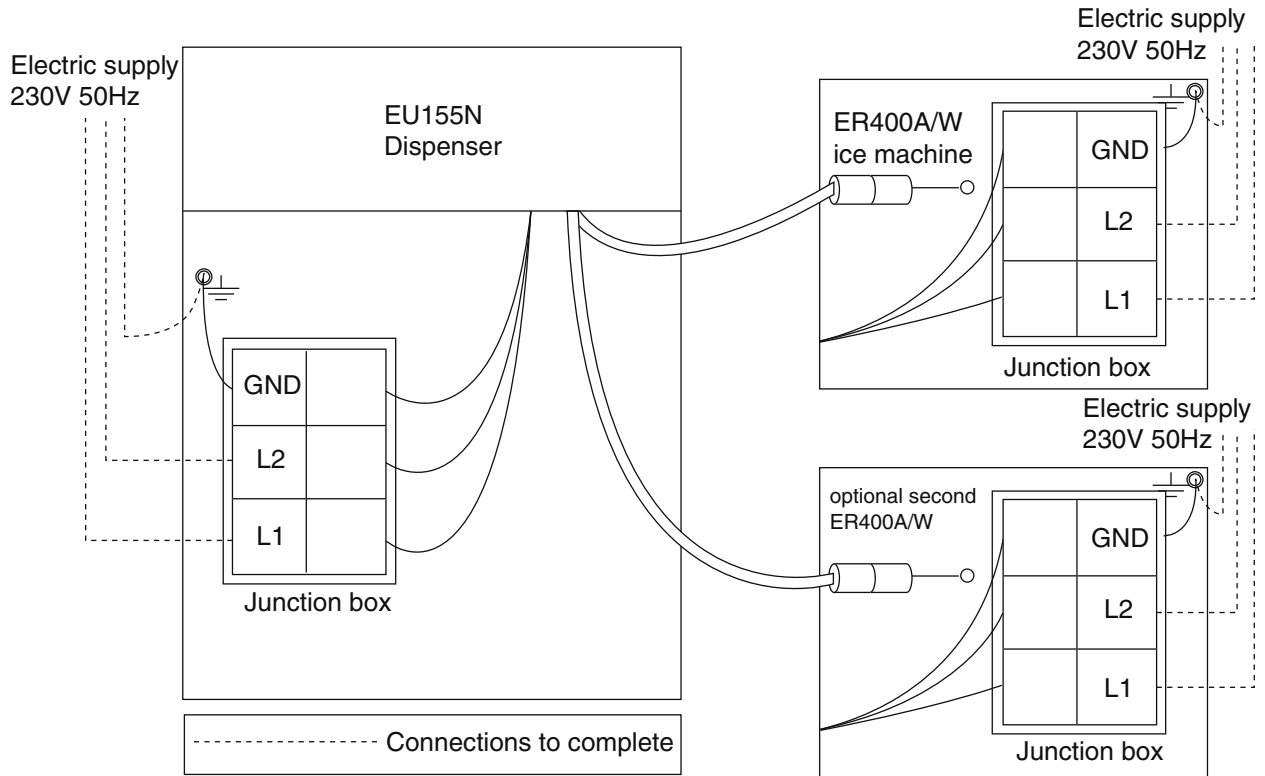

## Installation

### Installing EU155N dispenser in counter



All EU155N dispensers must be installed level in both directions and supported from below with 153 – 229mm adjustable legs provided, or channels installed on site. DO not hang dispenser on flange of counter.

1. Check that dispenser location meets all requirements in this manual and cut counter as shown.
2. Block up area below counter cut-out to support dispenser when lowered into place.
3. For automatic load dispensers, disconnect ice transport tube from bracket in storage area of dispenser. (Since this tube must be reinstalled in bracket after dispenser is dropped into counter, note how tube is held by bracket tabs before disconnecting.)
4. Carefully lower dispenser into counter until it rests on support blocks.
5. Adjust height from below with standard leg kit until dispenser flange rests flush with counter.
6. Apply a bead of NSF listed silicone sealant (Dow-Corning RTV-732 or equivalent) approximately 6mm in diameter around perimeter of dispenser where it meets counter and smooth sealant to a 4mm radius.
7. Install a hard drain line, maintaining at least a 6mm per 304mm run slope, and insulate line to prevent



PVC pipe is suggested. Care must be taken in sweating any metal drain pipe used. Excessive heat applied while sweating metal pipe may melt plastic fitting on dispenser. condensation.

8. Make electrical connections in accordance with applicable wiring diagrams provided, as well as NEC and local codes. Provide disconnects within 3m of dispenser and ice machine for servicing.

Counter cut-out

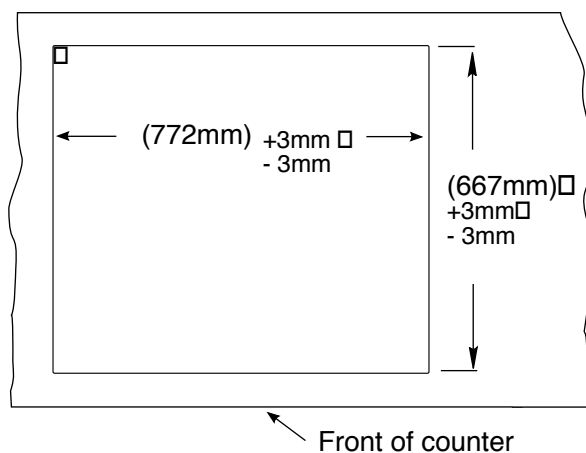

## Installing remote ice machine (automatic load units only)



Correct installation of remote ice machine(s) is critical to proper performance of ice machine and dispenser.

Check to make sure bin signal on ice machine control board is switched to 24 V connection.

Refer to installation manual packed with ice machine for important details on ice transport tube run, ventilation requirements and other installation requirements. Failure to comply with instructions will void warranty.

1. Position ice machine in desired location.
2. Push one end of ice transport tube(s) through hole(s) provided in side of dispenser.
3. Route tube into ice tube bracket inside dispenser and engage bracket tabs in holes located in end of ice transport tube(s). (See drawings below.)
4. Proceed with ice transport tube installation from dispenser to ice machine in compliance with instructions contained in ice machine installation manual packed with ice machine.

Ice tube retainer bracket

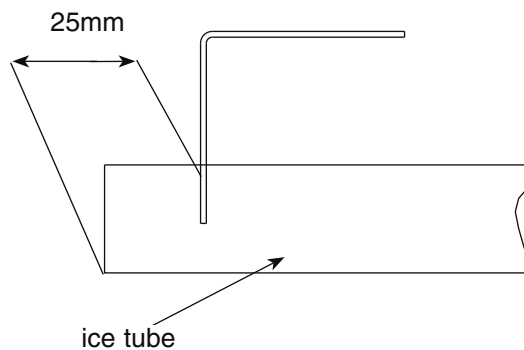
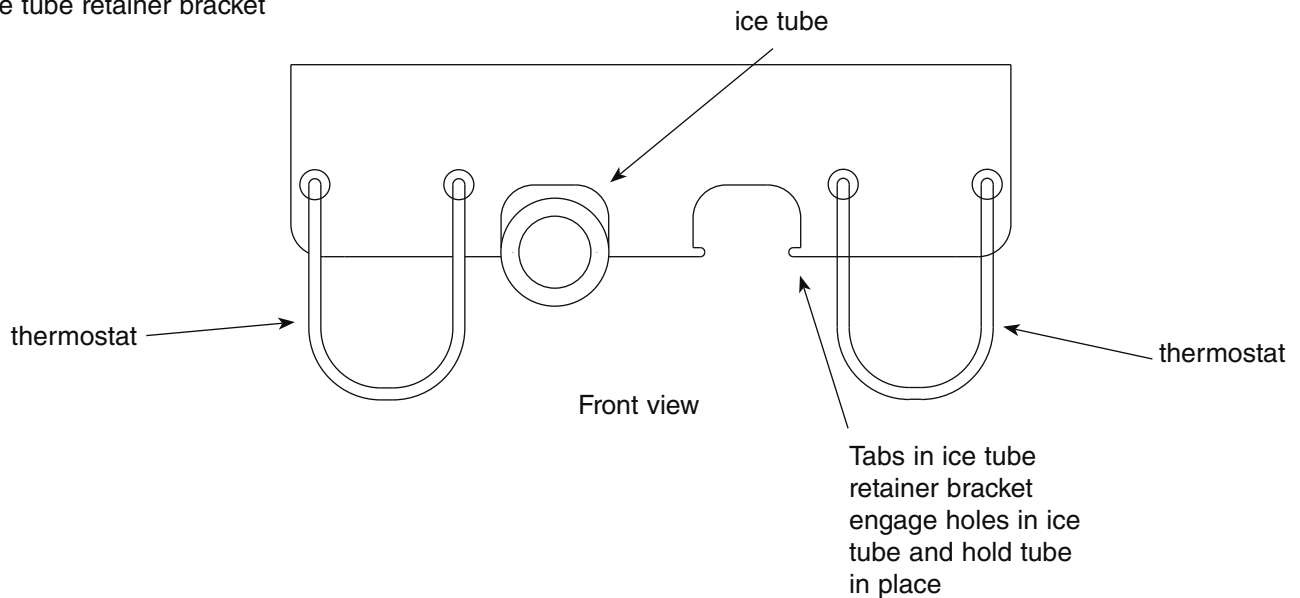



## To start up and operate dispenser

---

1. Follow detailed cleaning instructions in service manual before operating dispenser.
2. For manual load units, remove front drain pan or rear lid and fill storage area with compatible ice.



*Follett manual load dispensers can accommodate most cube/cubelet ices up to 26mm square and Follett compressed nugget ice. Crushed, flake, nugget, bagged or congealed ice cannot be used. Use of these ices can jam dispenser and void warranty. Separate any “waffle-like” sections of cubes before adding to dispenser. For questions about ice compatibility, call Follett’s customer service group at (610) 252-7301.*

3. Turn power switch located on control box to “ON” position.
4. For automatic fill units, follow detailed instructions in ice machine installation section of installation manual, then turn ice machine (bin signal) switch(es) located on control box to “ON” position and begin to make ice.
5. When dispenser has at least 153mm of ice in storage area, press “PUSH FOR ICE” lever or button to ensure that dispenser is operating properly. Note: If additional start-up information is needed, call Follett Corporation at +1 (610) 252-7301.

## User information

---

### How the dispenser works

Follett's EU155N Series ice and water dispensers are available in manual load configurations (using ice from another source) or automatic load configurations, fed from one or two Follett 400 lb (181kg)/day remote ice machines.

In all models, ice is stored below the counter in the dispenser storage area. When the dispense lever or button is pushed, the dispense motor is activated. This causes the wheel assembly in the storage area to turn, moving ice to the vertical auger assembly, which carries ice up to the dispense chute where it drops by gravity into the container.

In automatic load units, ice is manufactured in either one or two Follett remote ice machines. These ice machines may be located up to 6m away from the dispenser. As water freezes to the inside walls of the ice machine evaporator, a rotating stainless steel auger removes ice and carries it to the top of the evaporator assembly where it is compressed and extruded through an outlet port. The extruded ice is then pushed through the tube to the storage compartment of the dispenser. A level fill circuit maximizes fill in the storage area by rotating the wheel at intervals until the bin is completely filled. When the bin is filled, a bin stat shuts the ice machine off to avoid overfilling of the bin. The ice machine will restart after 20 minutes if the bin is calling for ice.

## Cleaning and sanitizing procedures

---



### **Warning!**

*Always disconnect power before cleaning dispenser.*

Using solutions below, clean and sanitize storage area and beverage lines before starting up unit and on a routine basis as noted below.

**Solution A:** Prepare a cleaning solution (200 ppm of available chlorine content) of chlorinated detergent. Cleaning solution temperature must be at 75° – 125°F (24° to 52°C).

**Solution B:** Prepare a sanitizing solution (50 ppm of available chlorine content) of chlorinated detergent. Sanitizing solution temperature must be at 75° – 125°F (24° to 52°C).

## Cleaning bin before use

1. Wipe storage area with Solution A.
2. Rinse thoroughly with clear, potable water.
3. Wipe with Solution B to sanitize.

## Periodic cleaning of dispenser

### Recommended daily cleaning of drain pan

**Notice!**

*DO NOT run plastic parts (drain pan, dispense chute cover, dispense wheel) through a dishwasher.*

1. Remove all debris from drain pan.
2. Pour 1 gallon (4L) hot water into drain pan to keep drain lines clear.

### Recommended weekly cleaning

1. Remove drain pan and grill and wash with Solution A. Rinse thoroughly.
2. Pour a solution of one cup (8oz/237ml) household bleach mixed with one gallon (3.8L) hot water into drain pan to help prevent algae growth in drain lines.

### Recommended quarterly cleaning (every 3 months)

**Notice!**

*On push button units, remove dispense switch from dispense chute cover before*

1. Turn power switch to "OFF" position and remove top from dispenser.
2. Remove ice from storage area.
3. Remove dispense chute cover, chute, auger motor assembly, auger and auger tube (page 10).
4. Remove drain pan, grille, dispense wheel and cover plate (page 11).
5. Clean all components and bin storage area with Solution A, rinse thoroughly with clear water and sanitize with Solution B.
6. Remove clean-out plug from drain line tee on side opposite dispense tower and let bath drain.
7. Use a bottle brush to clean coil with Solution A, then rinse and sanitize with Solution B.
8. Reinstall clean-out plug in drain line tee.
9. Pour potable water into bath to submerge coil.

### Putting unit back in service after quarterly cleaning

1. Reassemble components.
2. For manual load units, fill unit with an approved ice (see caution statement on page 1).
3. For automatic load units with R400A/W (R404A refrigerant) ice machines, turn bin signal switch(es) and dispenser power switch to "ON" position and allow storage area to fill.
4. Push dispense button or lever to test that dispenser is functioning properly.

## Quarterly cleaning of ice machine system

Units equipped with ice machines require cleaning of ice machine system at least every three months, and more often if local water conditions dictate. Failure to clean ice machine system will result in decreased performance and potential damage to ice machine. Refer to Ice machine Operation and Service Manual.

## Disassembly instructions for periodic cleaning

### Dispense chute cover removal

1. Remove top cover.
2. Push chute cover up vertically to slip off holding tab.
3. After clearing tab, pull chute cover forward to remove.

### Dispense mechanism assembly removal

1. Remove top cover.
2. Remove chute cover (see above).
3. Remove auger motor assembly (see above).
4. Remove quick release pins from the ice chutes and gates, then unplug wires from solenoids.
5. Lift dispense mechanism up and off auger tube.

### Auger and auger tube removal (Fig. 3)

1. Remove auger motor and dispense mechanism assembly (see above).
2. Pull auger upward to clear auger tube.
3. Lift auger tube upward to clear dispenser top.
4. Slide tube and bearing plate through auger tube gasket.

### Dispense wheel removal

1. Remove drain pan assembly and bin access cover.
2. Remove center thumbnut and threaded rod on dispense wheel assembly and lift wheel out front access opening.

### Auger motor assembly removal

1. Remove top cover.
2. Remove one thumbnut on rear of motor bracket.
3. Lift motor bracket up and unplug electric quick disconnects.
4. Remove motor assembly.

Fig. 1

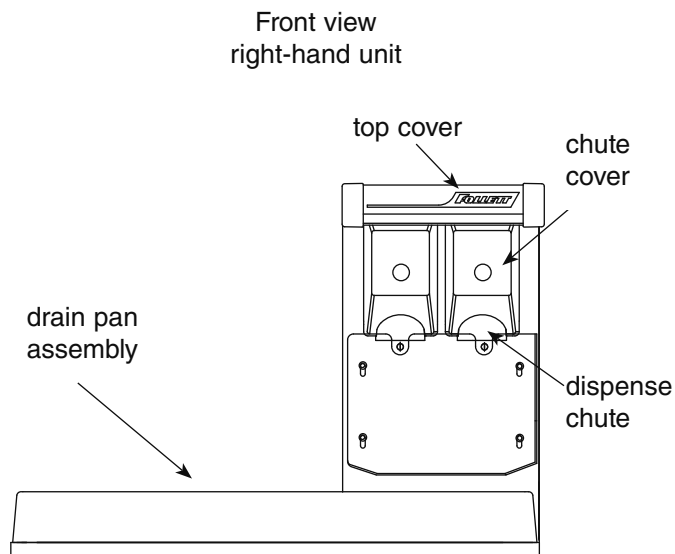

Fig. 2

Dispense assembly, top view  
right-hand unit

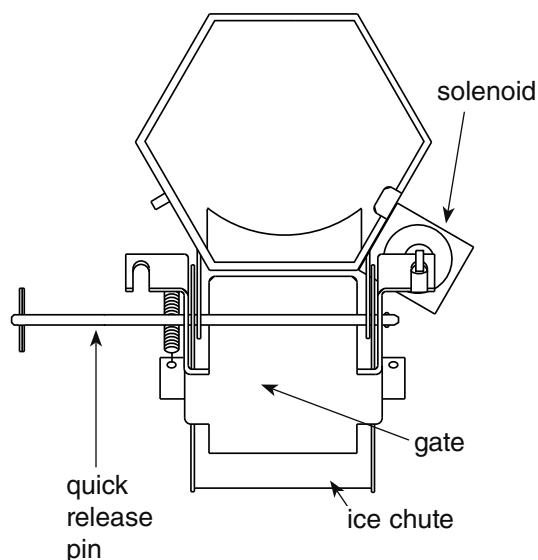
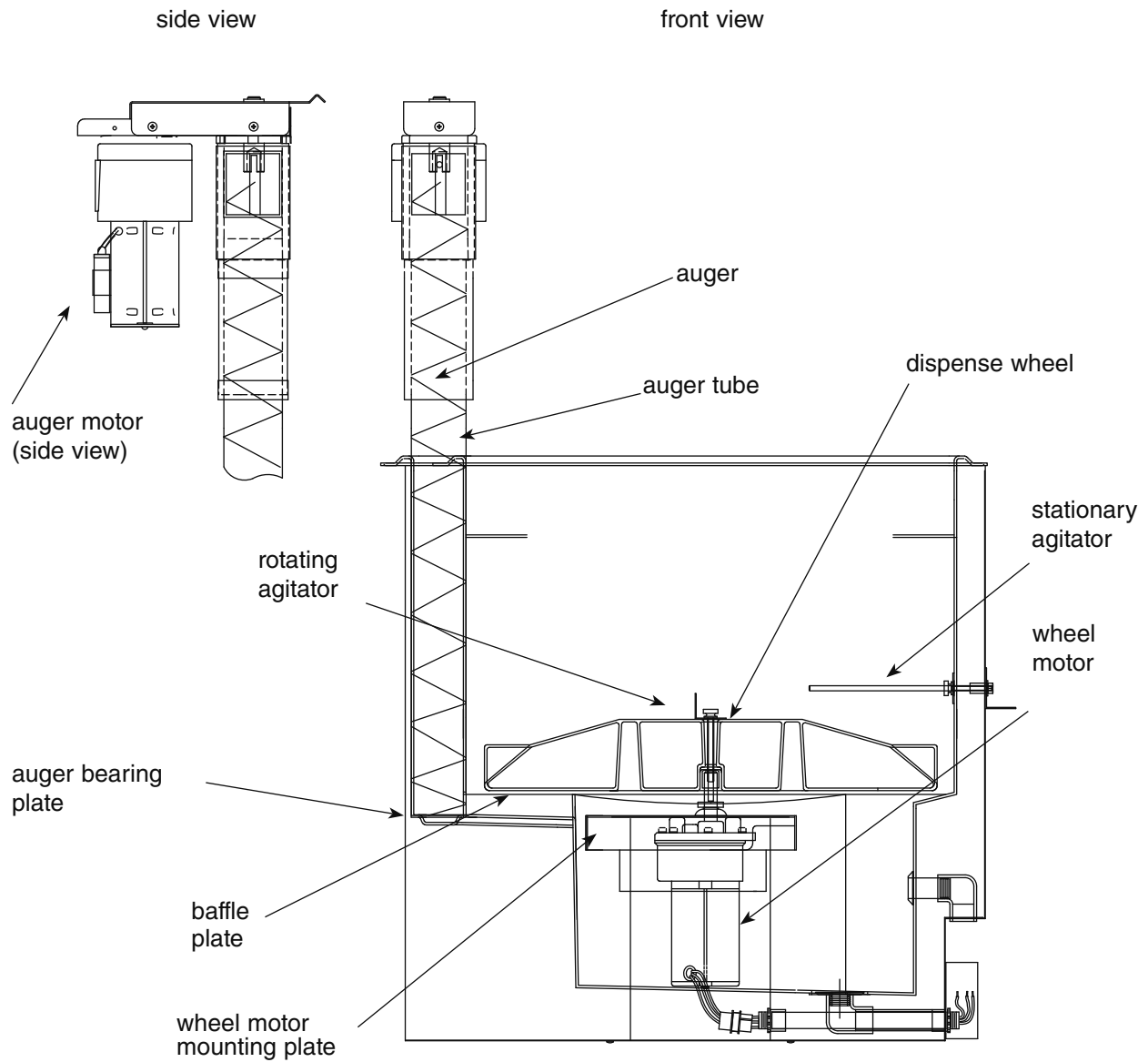

Fig. 3



## Service

Disassembly instructions for service requirements only – NOT required for any cleaning procedure.

### Dispense wheel motor removal (Fig. 3)

1. Remove drain pan, bin access cover and dispense wheel.
2. Remove stainless steel baffle plate under dispense wheel.
3. Remove two screws holding wheel motor bracket on bin.
4. Lift plate and motor up.
5. Unplug electric quick disconnects from motor.
6. Lift motor and mounting plate out front access opening.

Wiring diagrams

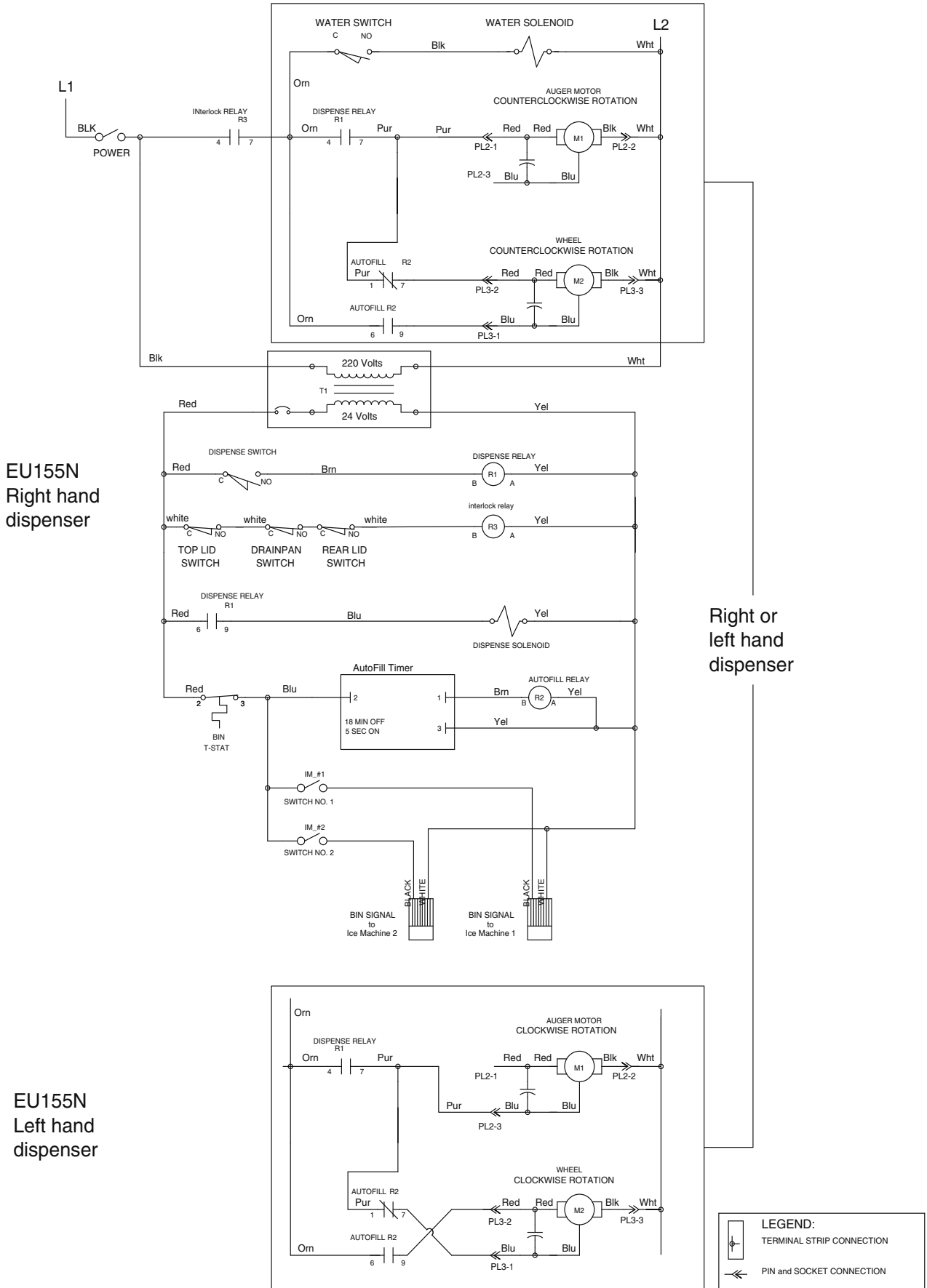

## Before calling for service

1. Check that there is ice in dispenser and that congealed cubes are not causing a jam.
2. Check that circuit breaker and switches are in "ON" position.
3. Check that drain pan, rear lid and top are on securely. If ajar, dispenser will not operate. When the top is off, auger does not operate, even though the solenoids do.
4. Check that all drains are clear.

**Note:** For units equipped with Follett compressed nugget ice machine, see Ice machine Operation and Service Manual for service and troubleshooting information.

## Dispenser troubleshooting guide

Symptom	Possible cause	Solution
Ice does not dispense. • Auger motor does not run • Wheel motor does not run	1. Power switch faulty or in OFF position; loose connection. 2. Faulty dispense switch. 3. Faulty transformer. 4. Drain pan ajar. 5. Faulty drain pan safety switch.	1. Turn power switch to ON position; check connections. 2. Replace switch. 3. Replace transformer. 4. Check pan and reseal. 5. Replace switch.
Ice does not dispense. • Auger motor runs • Wheel motor runs • Gate does not open	1. Loose electrical connection. 2. Linkage problem between solenoid and gate. 3. Faulty solenoid.	1. Check connections. 2. Check linkage. 3. Replace solenoid.
Ice does not dispense. • Auger motor does not run • Wheel motor runs	1. Loose electrical connection. 2. Faulty auger motor. 3. Faulty run capacitor.	1. Check connections. 2. Check auger motor. 3. Check run capacitor.
Ice does not dispense. • Auger motor runs • Wheel motor does not run	1. Loose electrical connection. 2. Faulty wheel motor. 3. Faulty run capacitor.	1. Check connections. 2. Check wheel motor. 3. Check capacitor.
No ice in dispenser.	1. Power switch in OFF position or faulty. 2. Bin signal switches in OFF position or faulty. 3. Faulty bin t-stat. 4. Faulty transformer. 5. Ice machine related problem. 6. Faulty run capacitor.	1. Check switch and replace if necessary. 2. Check switch and replace if necessary. 3. Replace bin t-stat. 4. Replace transformer. 5. Refer to ice machine Operation and Service Manual for diagnosing. 6. Check for power and bin signal on ice machine PC board.

If problems persist after following this basic troubleshooting guide, call Follett's technical service department at +1 (610) 252-7301.

# Replacement parts

## Dispenser exterior

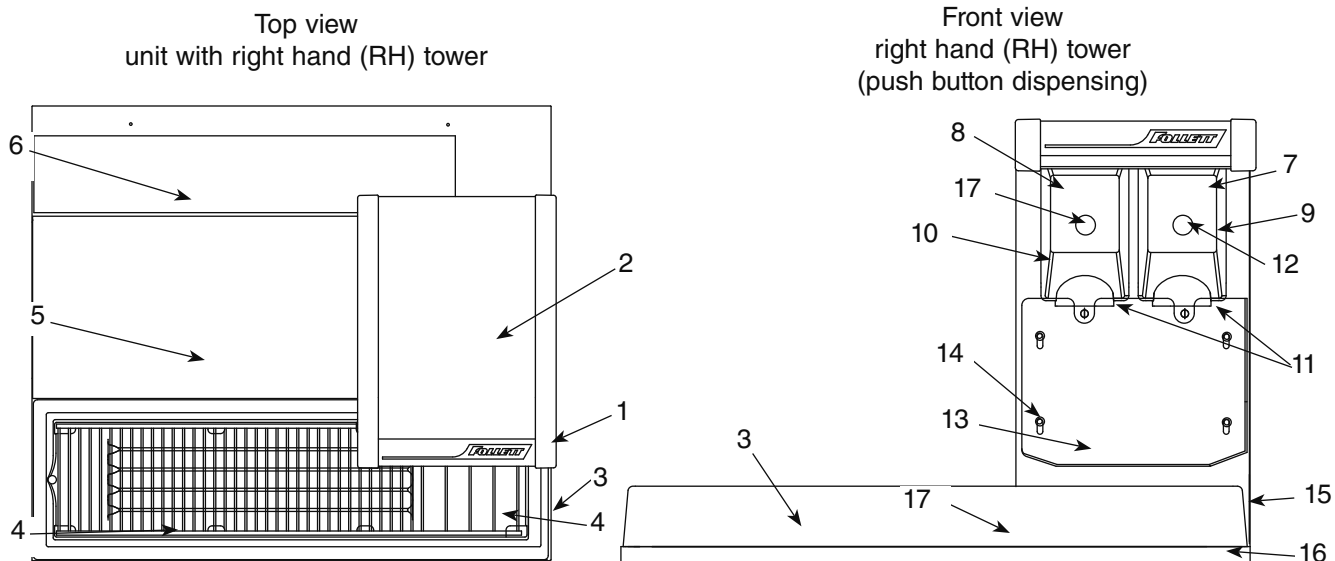

Reference #	Description	Part #
1	Label, "Follett"	502438
2	Top cover (includes label and magnet)	502905
3	Drain pan (includes magnet)	502903
4	Grille, drain pan	502450
5	Cover, electrical components	502902
6	Lid, rear access (includes magnet)	502904
Not shown	Cover, ice storage (under drain pan)	502453
7	Label, ice, dispense cover, push button	502623
8	Label, water, dispense cover, push button	502617
9	Cover, dispense chute, push button operation (includes button and label), ice	502440
10	Cover, dispense chute, push button operation (includes button and label), water	502440
11	Chute, focus, clear plastic	502459
Not shown	Push pin, clear chute	502610
12	Switch, push button operation, for ice (includes label)	502441
13	Splash shield, right hand unit	502612
Not shown	Splash shield, left hand unit	502613
14	Thumbscrew, splash shield, 10-32 x 1/2	501100
Not shown	Panel, access, right hand and left hand units	502907
16	Panel, wrap, right hand unit	502909
Not shown	Panel, wrap, left hand unit	502908
Not shown	Panel, rear, motor support, right hand unit	502586
Not shown	Panel, rear, motor support, left hand unit	502587
Not shown	Clip, Tinnerman, 10-32	502621
Not shown	Screw, 10-32 x 1/2	502287
Not shown	Legs, 153mm adjustable to 229mm, set of 4	502454
17	Switch, water dispense, push button operation (includes label)	502648
Not shown	Plug 2 lead, male	502333
Not shown	Plug 2 lead, female	502334

## Dispense assembly – side view

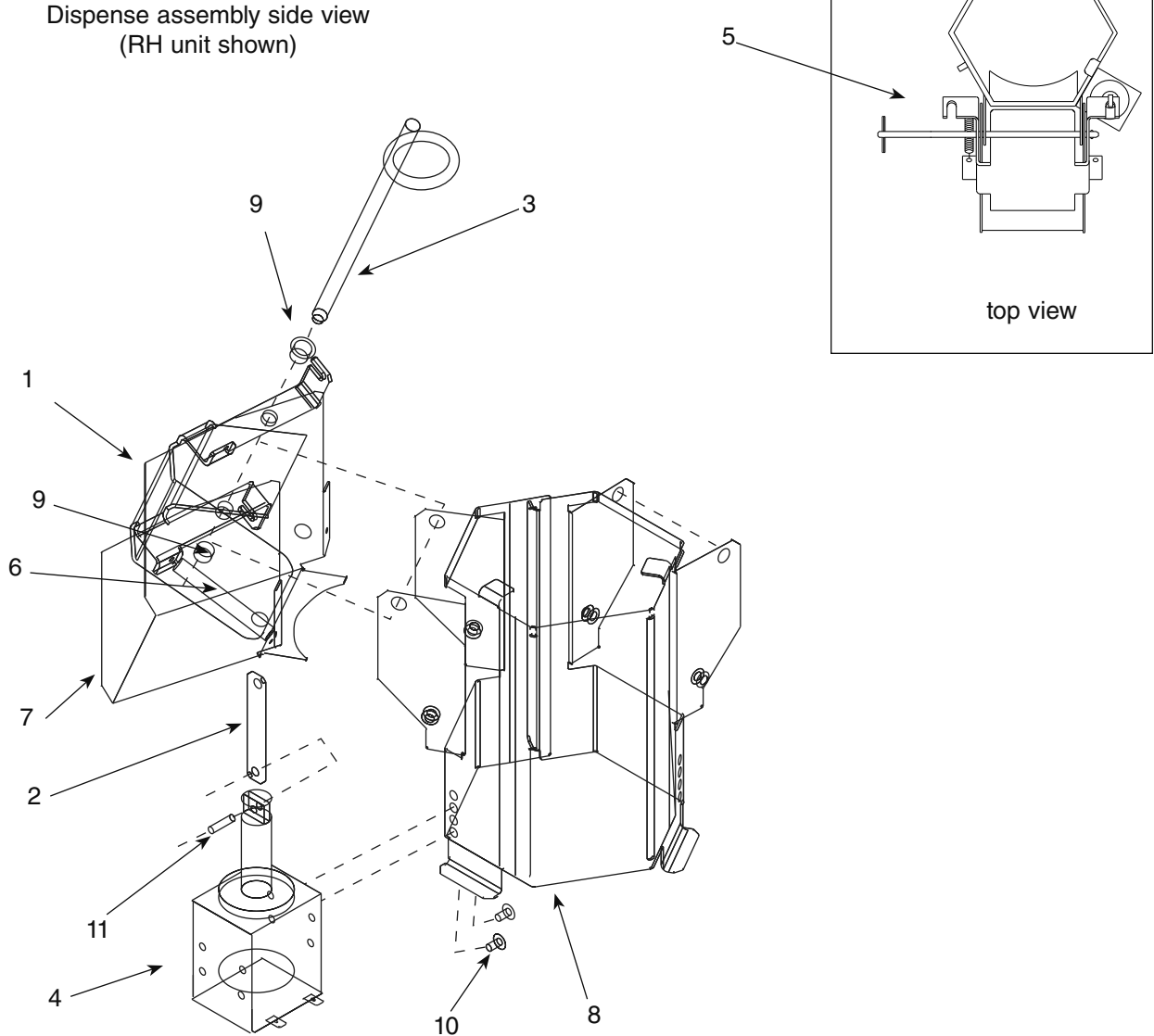

Reference #	Description	Part #
1	Gate, dispense	502455
2	Linkage pin, gate/solenoid	502456
3	Pin, quick release, 141mm, dispense gate	502102
4	Solenoid (includes linkage pin)	00120295
5	Dispense mechanism assembly, right hand unit	502458
Not shown	Dispense mechanism assembly, left hand unit	502496
6	Spring, dispense mechanism (1 per side)	501950
7	Chute, ice	502457
8	Wrap, dispense mechanism	502607
9	Bushing, Ni liners	501249
10	Screw, 8-32 x 5/16	502625
11	Pin, spring	502624



## Hopper – side view

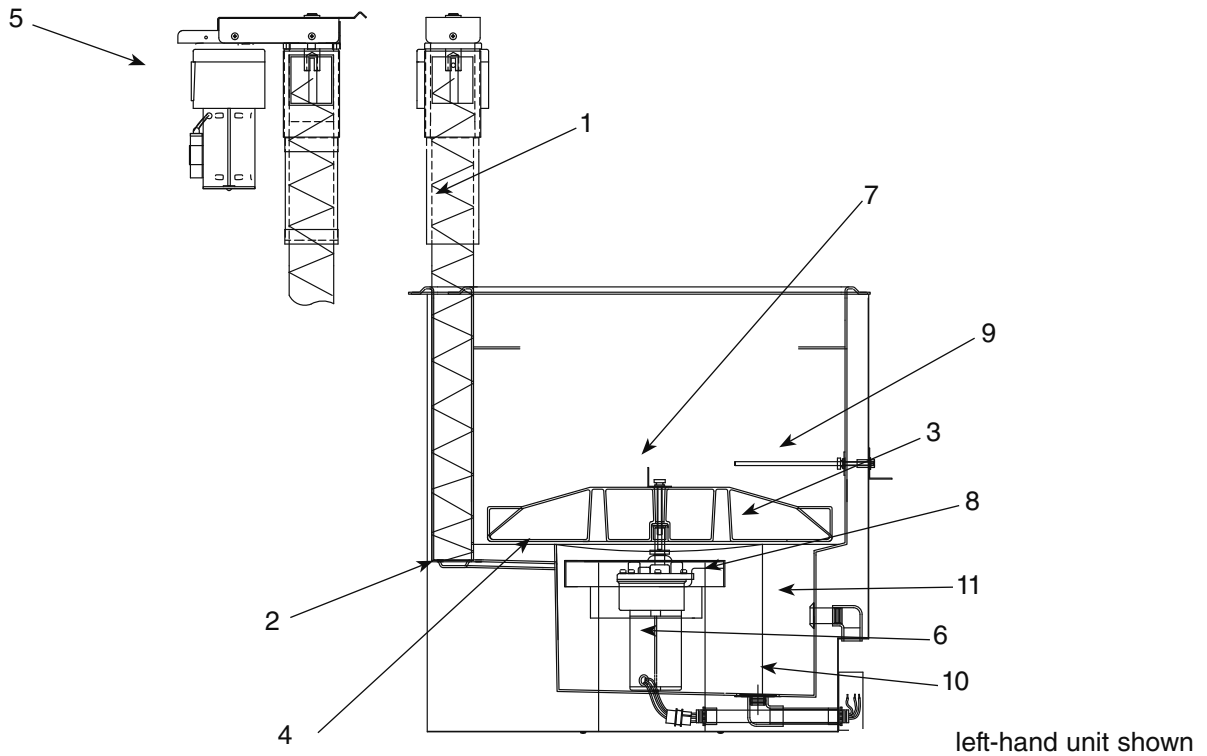

Reference #	Description	Part #
1	Auger, LH unit (black, stamped with "1")	502491
Not shown	Auger, RH unit (gray, stamped with "2")	502492
2	Plate, auger bearing	501696
Not shown	Tube, auger, right hand unit	502487
Not shown	Tube, auger, left hand unit	502488
3	Wheel, dispense (includes stud and rotating agitator)	501681
4	Baffle (under dispense wheel)	501684
Not shown	Drive bar (under dispense wheel)	501682
5	Motor, vertical auger	502889
6	Motor, wheel	502890
Not shown	Seal, wheel motor	501333
Not shown	Spacer, wheel motor	501768
Not shown	Capacitor, wheel motor	502891
7	Agitator, rotating, 534mm long	502484
8	Plate, wheel motor mounting	502615
9	Agitator, stationery	502490
Not shown	Bracket, ice tube, double tube	502497
Not shown	Ice transport tube (sold by the foot)	500366
Not shown	Ice transport tube, 10 ft	502522
Not shown	Ice transport tube, 20 ft	502523
Not shown	Insulation, transport tube (sold by the foot)	501176
10	Coil, plain water	502461
11	Tubing, water (sold by the foot)	502356
Not shown	Cover, blank ice entry	502674
Not shown	Gasket, ice entry	502672
Not shown	Plate, ice entry, 2 holes	502673

# Auger motor

side view

top view

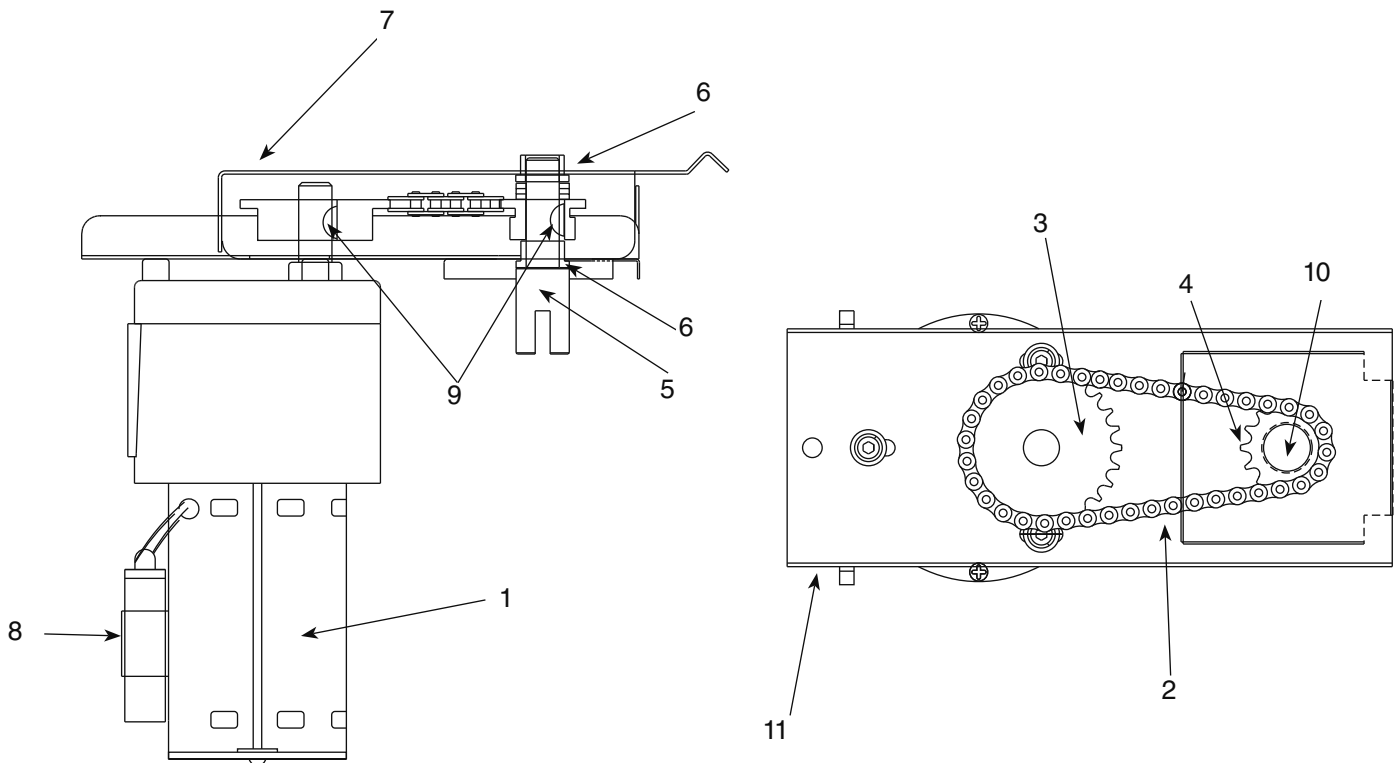

Reference #	Description	Part #
	Auger motor/drive assembly, vertical (includes all items below)	5028931
1	Motor, vertical auger (includes gearbox and capacitor)	502889
2	Chain, auger drive #35, 40p	502477
3	Sprocket 35#, 22T 5/8 bore	50247
4	Sprocket 35#, 12T 5/8 bore	502479
5	Drive shaft	502480
6	Bearing, auger, upper and lower	501314
7	Cover and bearing, chain drive (includes 501314)	502912
8	Capacitor, 25mf, 270V	502892
9	Key, Woodruff	502482
10	Washers, thrust (4)	501765
11	Mounting plate, auger motor (includes 501314)	502913

## Electrical components

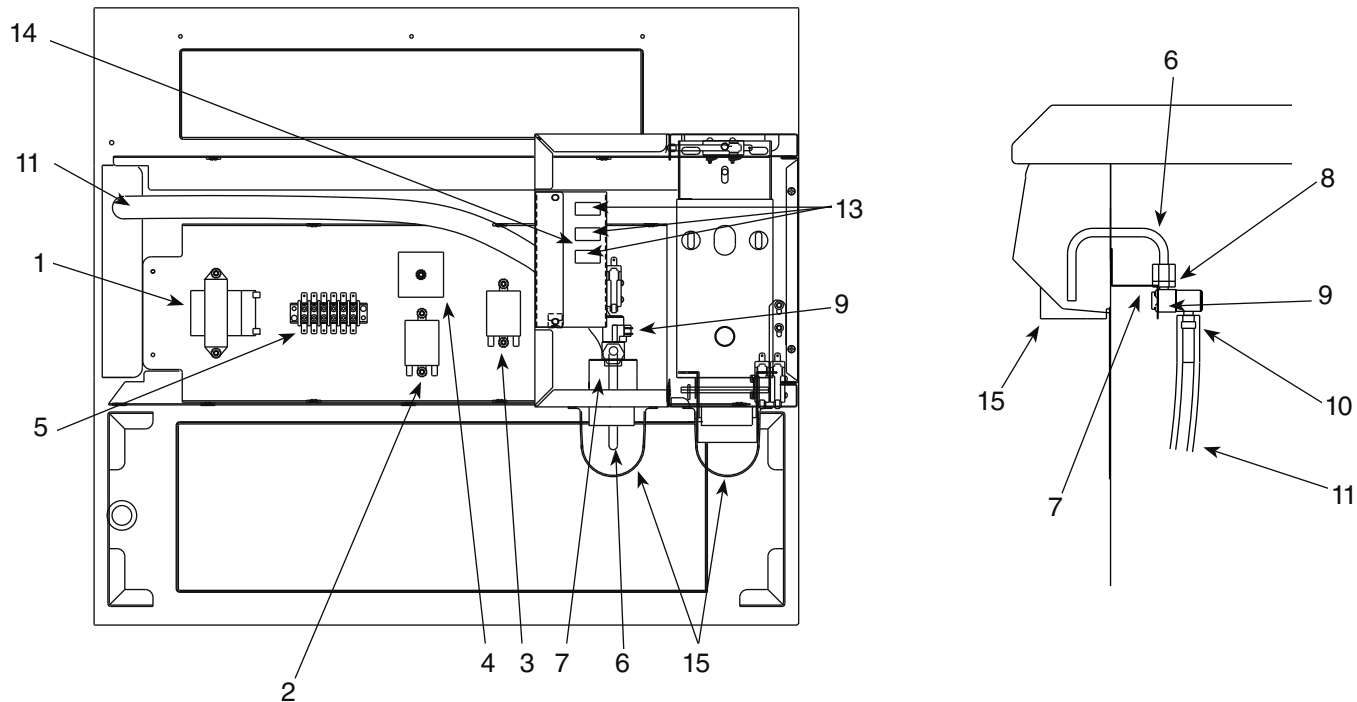

Reference #	Description	Part #
1	Transformer, 24V	502885
2	Relay, dispense	501826
3	Relay, auto fill	501826
4	Timer, auto fill (automatic fill units)	502471
5	Strip, terminal	502472
6	Tube, water dispense, stainless steel	502356
7	Bracket, water solenoid	502611
8	Fitting, outlet, 1/8 MPT x 3/8, compression	502562
9	Valve, solenoid, water	208103
10	Fitting, inlet, plastic, 1/4 barb	502637
11	Tubing, water (sold by the foot)	502356
13	Switches (power and ice machine)	502209
14	Bracket, switch mounting, RH (power and ice machine)	502914
Not shown	Bracket, switch mounting, LH (power and ice machine)	502906
15	Chute, focus, clear plastic	502459
Not shown	Thermostat, bin level	501432
Not shown	Magnetic switch (1) one located under top cover (2) two located under electrical component cover	502887
Not shown	Magnets (2) two located on drain pan (1) one located on top cover (1) one located on rear cover	502888

SafeCLEAN and SensorSAFE are trademarks of Follett Corporation.

Chewblet and Follett are registered trademarks, and Horizon is a trademark of Follett Corporation, registered in US.



801 Church Lane • Easton, PA 18040, USA  
Toll free (877) 612-5086 • +1 (610) 252-7301  
[www.follettice.com](http://www.follettice.com)



00120303R02  
03/12