

Single Door Upright Ice Storage Bins with SmartGATE® Ice Shield

Order parts online
www.follettice.com

Installation Instructions and Parts List

Welcome to Follett

Follett ice storage bins enjoy a well-deserved reputation for excellent performance, long-term reliability and outstanding after-the-sale support. To ensure that this bin delivers that same degree of service, we ask that you take a moment to review this instruction before beginning the installation of the bin. Should you have any questions or require technical help at any point, please call our technical service group at (877) 612 5086 (US & Canada) or +1 610 252 7301 and in Poland: +48 58 785 6140.

Before you begin

After uncrating and removing all packing material, inspect the equipment for concealed shipping damage. If damage is found, notify the shipper immediately and contact Follett Corporation so that we can help in the filing of a claim, if necessary.

Important cautions

- Top is **NOT** fastened to bin.
- Avoid excessive tightening force when connecting to the bin drain fitting.
- Do not apply excessive heat if any sweating of fittings is necessary. Heat conduction through metal may melt threads in plastic drain fitting.
- When leveling, do not extend any leg more than 1 in. (26mm) for total leg height no greater than 2.125 in. (54mm).
- SDU1000: Legs **must** be secured to floor through feet to avoid possible movement and resulting injury.

Installation

1. Remove all packing material from bin.
2. Remove all tape and temporary fastenings from door assemblies and outside of bin.
3. Remove top from bin.
4. Remove set of four legs and any other accessories packed inside bin.
5. Lay bin on back, being careful to protect finish, and remove bolts holding skid to bin.
6. Screw legs into tapped holes in bin bottom and tighten to seat legs well against bottom.
7. Set bin upright.
8. Reinstall top onto bin.
9. Remove protective paper from stainless steel exterior.
10. Move bin to permanent location.
11. Adjust "foot" at bottom of each leg to level bin in both directions.
12. Mount icemaker(s) on bin in accordance with icemaker manufacturer's instructions.
13. Connect drain line to 1" FPT female fitting located in bottom of bin.
14. Make final connections to icemaker.

Installing icemaker drain

(Required for some icemaker applications)

Some icemakers require a special drain system. For these machines Follett predrills the hole and provides the 3/4" straight threaded drain fitting to be installed through the hole. To install the fitting:

1. Remove plastic nut on fitting.
2. From inside bin (liner side), insert threaded portion through hole provided in side of bin.
3. Replace plastic nut on threaded portion and tighten against outside of bin.
4. Connect supplied tubing to icemaker drain connection after installing icemaker.

Installing icemaker tie-downs (Fig. 1)

(Required for some icemaker applications)

Certain icemaker/bin combinations require installation of a tie-down strap. If this fitting has been included with your bin, proceed as follows:

1. Locate back of icemaker flush with back of bin.
2. Using center of vertical slot as a template, drill through icemaker wall with 15/64 drill.
3. Fasten straps to icemaker and bin (bin holes are predrilled) with #14 x 1/2 sheet metal screws and washers provided.

Removing lower door assembly

(Only if required for access through narrow doors)

1. With door in closed position, remove Phillips head screw and washer from hinge area on each side of lower access door.
2. Insert screwdriver between door and hinge bracket on one side of door and gently push against bracket to provide room for door stud to clear bracket.
3. Remove access door.
4. Pull up on SmartGATE to remove.
5. Remove screws along top of door assembly.
6. Pull forward on top of assembly and lift to remove.

Reinstalling door assembly

1. Reinstall lower door assembly in bin opening.
2. Reinstall screws in hood at top of door assembly.
3. Reinstall SmartGATE in side panel tracks and push down to seat.
4. With door in closed position, insert one door stud through hinge bracket, install washer, screw and tighten.
Note: For proper operation the access door must be reinstalled in the closed position.
5. On other side, insert screwdriver between door and hinge bracket and gently push against bracket to provide room for door stud to clear bracket.
6. Reinstall washer and screw in lift door and tighten.
7. Check door to ensure proper operation.

Operation

SmartGATE operation

Follett's unique SmartGATE positively controls the flow of ice into lower door assembly area for removal with either a scoop or shovel. SmartGATE can also be adjusted and locked at one of several levels to accommodate flow characteristics of different types of ice.

Bin is shipped with SmartGATE in full down position. SmartGATE can be raised and locked in higher position for better flow or when more access is needed.

If more ice is needed in lower door area:

1. Use full-length handle at top of SmartGATE to gently lift and jiggle SmartGATE to encourage ice to flow into access area of the bin (Fig. 2). (Loose ice will cascade into lower door area.)
2. When adequate ice has flowed, push SmartGATE back down.

Fig. 1

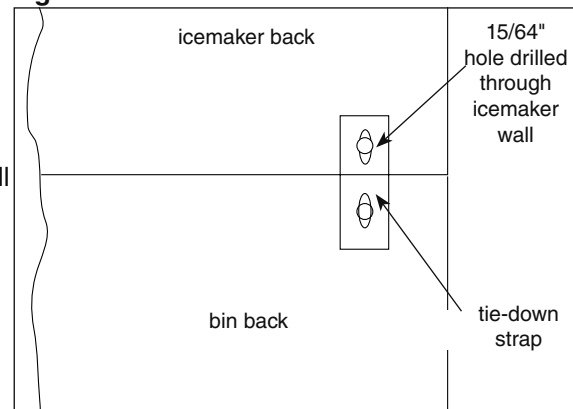

When more access is needed or to encourage flow of less “slippery” ice: **Fig. 2**

1. Lock gate at higher level by pulling up and holding SmartGATE at correct level, and pushing tapered end of catch into nearest hole in gate (catch will automatically release when you pull up).
2. To release catch, pull up on SmartGATE.

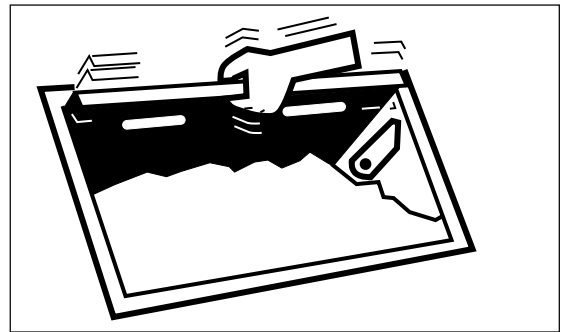

Using ice probe tool accessory

Ice probe tool is an optional accessory that can be ordered directly from Follett. If your bin has been ordered with ice probe tool accessory, mount probe for easy access on either side of bin in bracket provided.

Using probe

If there is adequate ice in bin but lower door area is not filled with ice, it may be that ice has congealed in bin and cannot flow. This can often be remedied by quickly jiggling SmartGATE several times (**Fig. 2**). If problem continues, probe tool can be inserted through rectangular openings in SmartGATE and agitated back and forth to break up congealed ice mass (**Fig. 3**).

Note: Use probe tool only as described above. To avoid possible injury, keep head and face clear of lower door area and tool at all times. Do not use probe tool for other purposes.

Fig. 3

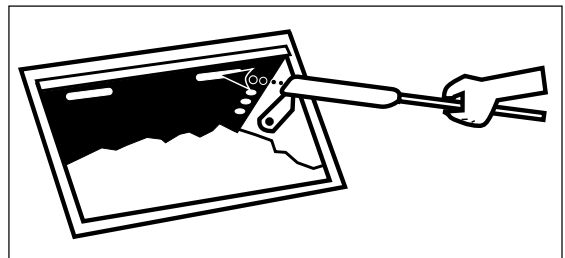

Technical assistance available toll free

Should you have any questions concerning installation or maintenance of Follett ice storage bins, please call our technical service department at 800 523 9361 or +1 610 252 7301 (US & Canada) between 8 a.m. and 5 p.m. Eastern time and in Poland +48 58 785 6140.

Cleaning

Interior of bin must be cleaned and sanitized prior to use and should be cleaned on routine basis during use.

Interior bin care

Follett single door upright ice storage bins with SmartGATE are equipped with polyethylene liner walls and stainless steel bottoms which should be cleaned and sanitized periodically with any product suitable for use in a food zone.

Important: Follett Corporation recommends installing a properly-sized, activated carbon (charcoal) water filter on water supply to icemaker to remove chlorine.

1. Remove upper inspection windows by sliding windows to one side. Grasp the end of the front window and pull toward you as the window is slid to the opposite side. Repeat for rear window.

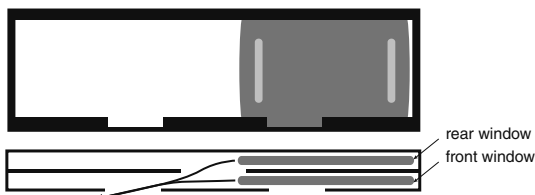

2. Wash bin walls, hopper, access door plate and partition (if any), rinse and sanitize.

Exterior bin care

Exterior stainless steel surfaces can be cleaned with a stainless steel cleaner such as 3M Stainless Steel Cleaner & Polish or equivalent.

Replacement parts

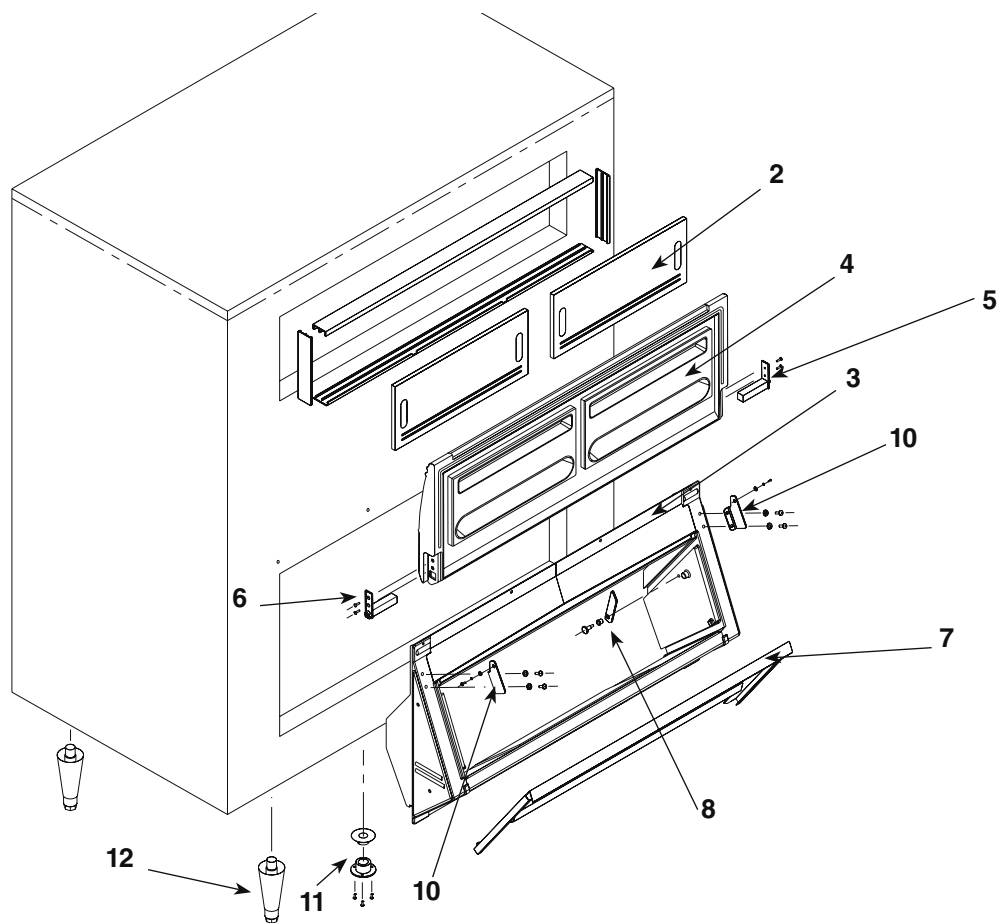

Reference #	Description	Part #
1	Track, inspection window (used with 502264 window)	501401
2	Inspection window, 21.125"W x 8.625"H (537mm W x 219mm H) (2 used per bin)	502237
2	Inspection window, 12.5"W x 9"H (318mm W x 229mm H) (2 used per bin)	502264
3	Frame assembly, lower door, 45" (1067mm) (includes 502177 and 502363)	502361
3	Frame assembly, lower door, 28 (686mm) (includes 502176 and 502367)	502365
4	Door, outer lift, 45" (1067mm) (includes 502178 and 502179)	502177
4	Door, outer lift 28" (686mm) (includes 502178 and 502179)	502176
5	Hinge, RH door mount (includes hardware)	502179
6	Hinge, LH door mount (includes hardware)	502178
7	Ice Gate, 40" (1067mm)	502363
7	Ice Gate, 24" (686mm)	502367
8	Catch, Ice Gate	502185
10	Hinge bracket, bin mount, LH/RH, (pair, includes hardware)	502180
11	Drain assembly, plastic	500977
12	Legs, 6" (153mm) stainless steel (set of 4)	500272
12	Legs, 6" (153mm) stainless steel flanged foot (set of 4) - <i>SDU1000 only</i>	501300
Not shown	Shovel, ice	501796
Not shown	Bracket, ice shovel	502360
Not shown	Rake, ice, 36"	502952
Not shown	Rake, ice, 48"	502303
Not shown	Bracket, rake	502872
Not shown	Paddle, ice, 46.5"	502871
Not shown	Paddle, ice, 59"	502063
Not shown	Bracket, paddle	502064

SmartGATE is a registered trademark of Follett Corporation, registered in the US.