

U300/UD300 Series Ice Dispensers

Order parts online
www.follettice.com

Operation, Service and Parts Manual Service Number A23719 to B22204

Single-sided dispensers

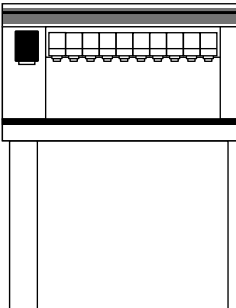

Model U300
Model U300B

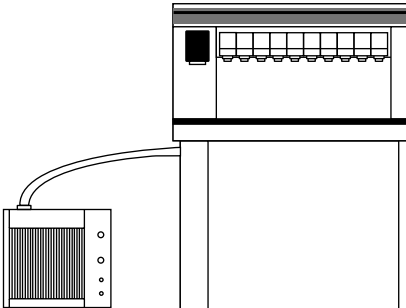

Model U300R400A/W
Model U300BR400A/W

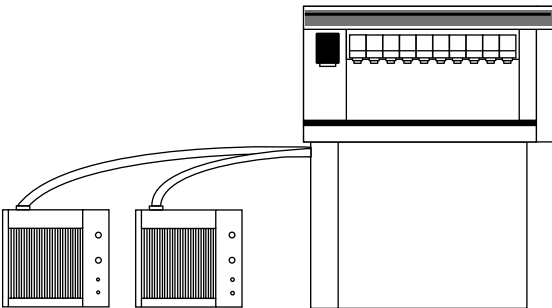

Model U300R800A/W
Model U300BR800A/W

Dual-sided dispensers

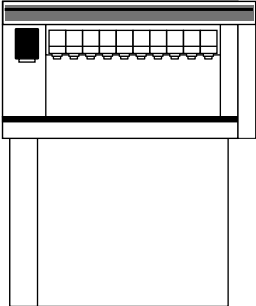

Model UD300

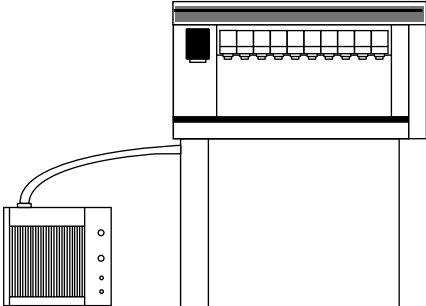

Model UD300R400A/W

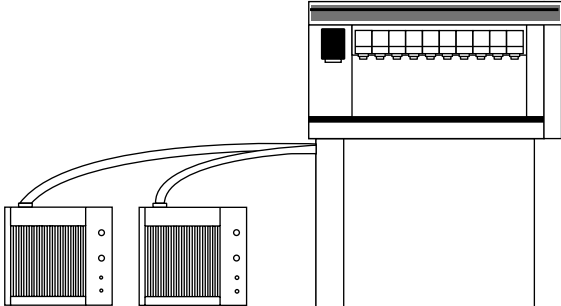

Model UD300R800A/W

Welcome to Follett

Follett ice dispensers enjoy a well-deserved reputation for excellent performance, long-term reliability and outstanding after-the-sale support. To ensure that this dispenser delivers that same degree of service, we ask that you take a moment to review this manual before using the dispenser. Should you have any questions or require technical help at any point, please call our technical service group at (800) 523-9361 or (610) 252-7301.

Before you begin

Check your paperwork to determine which model you have. Following is an explanation of the different model numbers in the U300 series.

U300BR400A

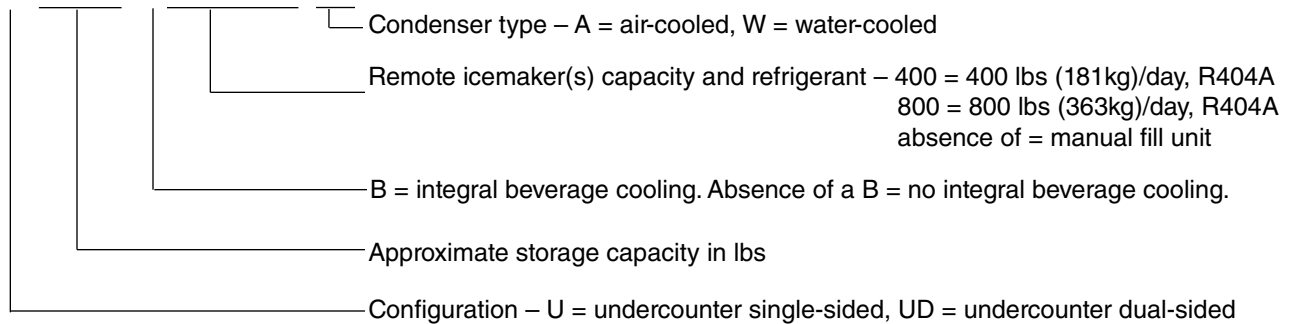

Important cautions

- Storage area of dispenser contains mechanical, moving parts. Keep hands and arms clear of this area at all times. If access to this area is required, power to unit must be disconnected first.
- **Follett manual load units accommodate most cube/cubelet ices up to 1" square and Follett compressed nugget ice. Crushed, flake, bagged or congealed ice cannot be used. Use of these ices can jam dispenser and void warranty. Separate any "waffle-like" sections of cubes before adding to dispenser. If you have questions concerning your ice type, call Follett's customer service group at (800) 523-9361 or (610) 252-7301.**
- Follett recommends use of an activated carbon filter for units equipped with icemakers.
- Ice is slippery. Maintain counters and floors around dispenser in a clean and ice-free condition.
- Ice is food. Follow cleaning instructions to maintain cleanliness of delivered ice.

Electrical Specifications – 115V, 60Hz, 1 phase



U300 series dispensers with remote icemaker(s) require separate circuit and disconnect for each icemaker and dispenser.

Single-sided models

U300 – dispenser 6.0 amps

U300B – dispenser 7.0 amps

U300R400A/W – dispenser 6.0 amps, icemaker 11.0 amps

U300BR400A/W – dispenser 7.0 amps, icemaker 11.0 amps

U300R800A/W – dispenser 6.0 amps, icemakers 11.0 amps each

U300BR800A/W – dispenser 7.0 amps, icemakers 11.0 amps each

Dual-sided models

UD300 – dispenser 8.0 amps

UD300R400A/W – dispenser 8.0 amps, icemaker 11.0 amps

UD300R800A/W – dispenser 8.0 amps, icemakers 11.0 amps each

Note: Each icemaker and dispenser require separate circuit with electrical disconnect within 10 feet (6m). Equipment ground required. Standard electrical – 115V, 60 Hz, 1 phase. Max. fuse dispenser – 15 amps; each icemaker – 20 amps.



On all models with remote icemaker(s), black wire on icemaker control board LINE VAC terminal must be moved to 24V terminal.

Plumbing



Do not reduce size of drain lines or tie drains together.

Dispenser – all models

3/4" PVC slip fit bin drain

1" PVC slip fit drain pan drain(s)

1" PVC slip fit beverage bath drain (units with beverage cooling only)

Note: Drains must be hard piped and insulated. Maintain 1/4" per foot (6mm per 304mm) min. slope

Icemaker – automatic load models only

1/4" FPT water in

1/2" MPT drain

3/8" FPT condenser inlet (water-cooled condenser only)

1/2" FPT condenser drain (water-cooled condenser only)

Note: Water disconnect within 10 feet (3m) of icemaker(s) is required for automatic load units

U300 series single-sided dispensers

Required clearances:

- 60" (1524mm) for installation
- 49" (1245mm) for auger removal

Front view

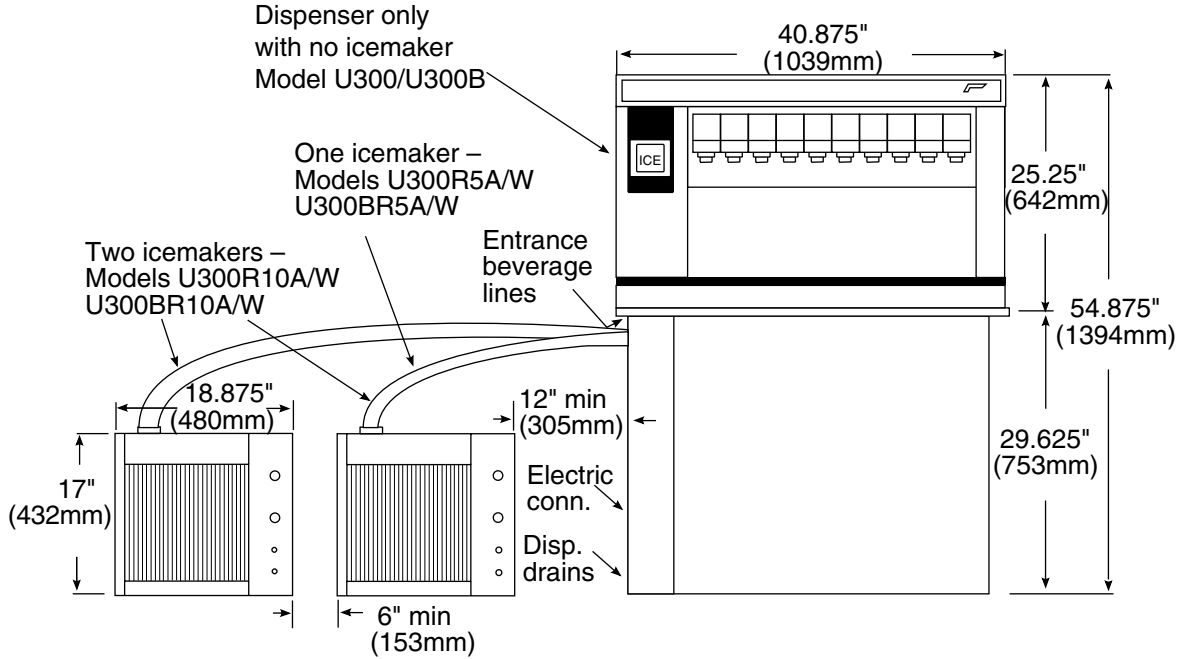

Side view – ice dispense chute

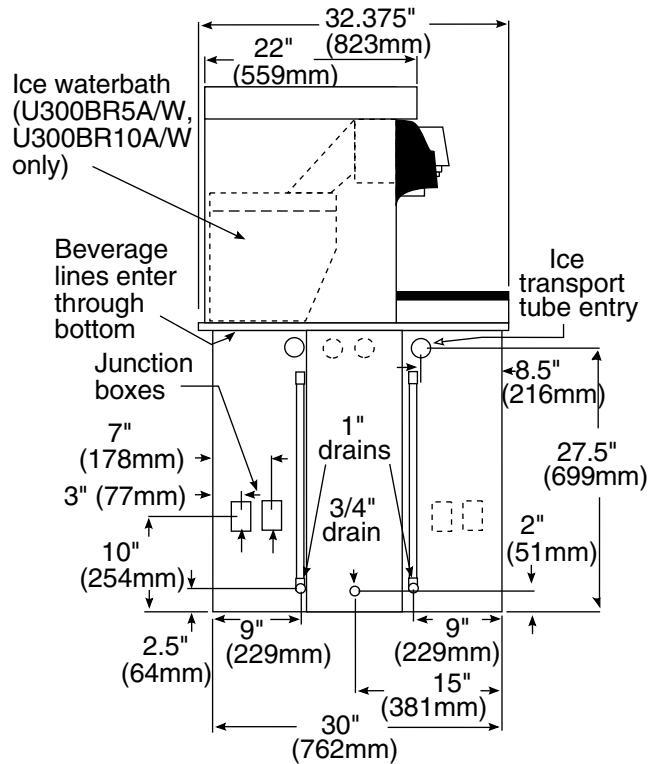

UD300 series dual-sided dispensers

Required clearances:

- 60" (1524mm) for installation
- 49" (1245mm) for auger removal

Front view

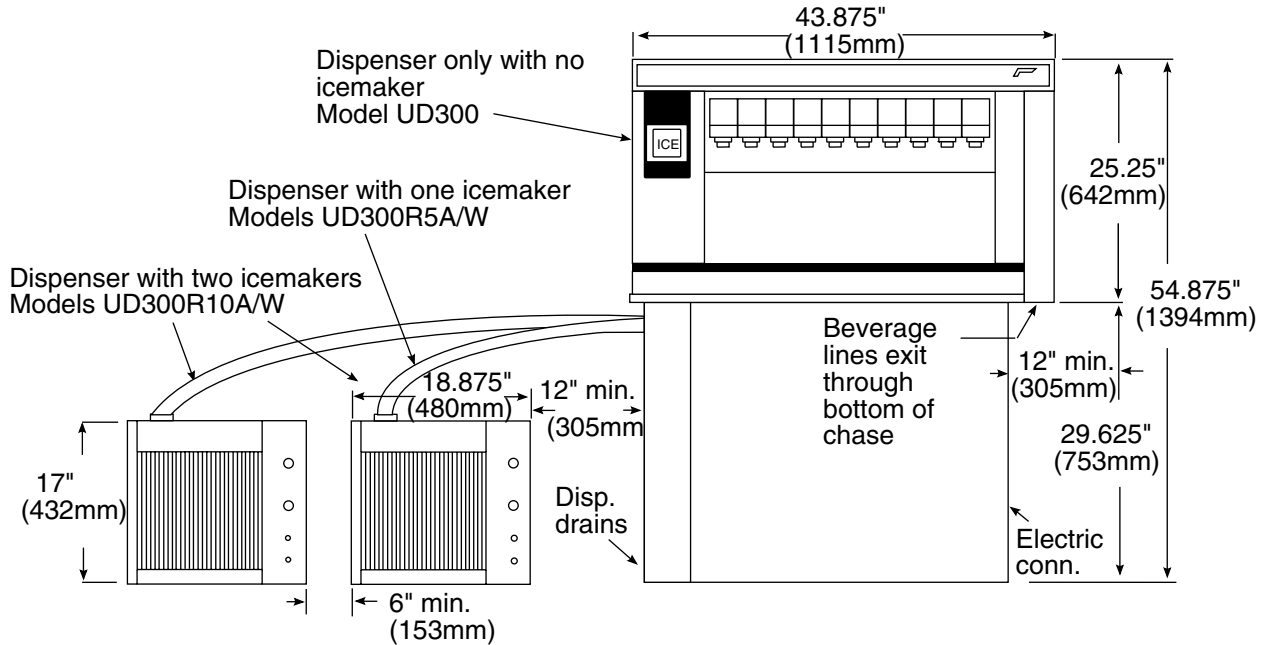

Side view - ice dispense chute

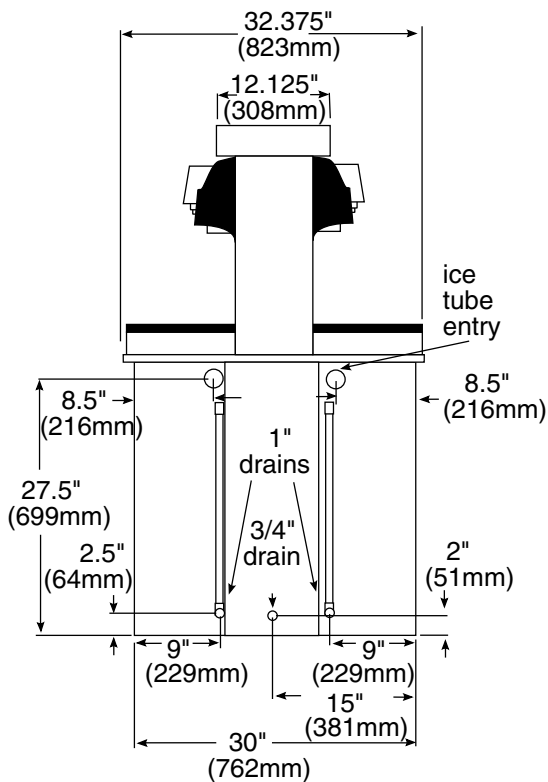

Side view opposite ice dispense chute

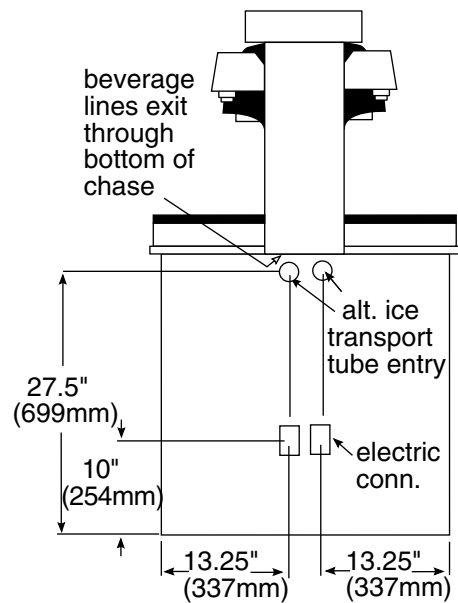

To start up and operate dispenser

1. Follow all cleaning and start-up instructions in U300 Installation Manual packed with dispenser before operating dispenser.
2. Turn power switches located under dispenser top to ON position.
3. For manual load models, remove drain pan and fill storage area with compatible ice. **(See caution on page 2 of this manual concerning ices which may be used in this dispenser.)**
4. For automatic fill models, turn icemaker (bin signal) switch(es) located inside dispenser top to ON position and begin to make ice.
5. When dispenser has at least 6" (153mm) of ice in storage area, press lever or button to ensure that dispenser is operating properly.

How dispenser works

Follett's single-sided U300 series and dual-sided UD300 series ice dispensers are available in manual load configurations (using ice from another source) or automatic load configurations (fed from one or two Follett 400 lb/day remote icemakers). An ice water bath beverage cooling system located directly behind valves is available for single-sided U300 series dispensers. Dual-sided units must use a separate mechanical cooling system to cool beverage lines.

In all models, ice is stored below counter in dispenser storage area. When dispense lever or button is pushed, dispense motor is activated. This causes wheel assembly in storage area to rotate counterclockwise, moving ice to vertical auger assembly. Vertical auger carries ice up to dispense chute where it drops by gravity into container.

In automatic load models, ice is manufactured in either one or two Follett remote icemakers. These icemakers may be located up to 20 ft (3m) away from dispenser. As water freezes to inside walls of icemaker evaporator, a rotating stainless steel auger removes ice and carries it to top of evaporator assembly where it is compressed and extruded through an outlet port. The extruded ice is then pushed through tube to storage compartment of dispenser. A bin thermostat shuts off icemaker when storage compartment is full.

Periodic cleaning of dispenser



Do NOT run plastic parts (drain pan, dispense chute cover, dispense wheel) through a dishwasher.

Solution A: Prepare cleaning solution (200 ppm available chlorine content) of Ecolab Mikro-chlor Cleaner or equal chlorinated detergent. Solution temperature must be at 75° – 125°F (23° – 52°C).

Solution B: Prepare sanitizing solution (50 ppm available chlorine content) of Ecolab Mikro-chlor Cleaner or equal chlorinated detergent. Solution temperature must be at 75° – 125°F (23° – 52°C).

Recommended daily cleaning of drain pan

1. Remove all debris from drain pan.
2. Pour 1 gallon (4L) hot water into drain pan to keep drain lines clear.

Recommended weekly cleaning

1. Remove drain pan(s) and grille(s) and wash with Solution A above. Rinse thoroughly.
2. On units with beverage valves, remove nozzles and diffusers from valves, soak for at least 10 minutes in cleaning Solution A, rinse, sanitize with Solution B and reinstall.
3. Pour a solution of one cup (8 oz/237ml) household bleach mixed with one gallon (3.8L) hot water into drain pan(s) to help prevent algae growth in drain lines.

Recommended quarterly cleaning (every 3 months)

1. Empty all ice from dispenser.
2. Remove dispenser top and turn bin signal switch(es) and dispenser power switch to OFF position.
3. Remove dispenser drain pan(s) and grille(s).
4. Remove thumbscrews from splash panel, lift up and out at bottom of panel and remove.
5. Remove chute cover(s), dispense chute(s), auger tube and auger (see disassembly instructions).

6. Remove yoke rods, drive shaft and dispense wheel (see disassembly instructions).
7. Clean all components and bin storage area with Solution A, rinse thoroughly with clear water and sanitize with Solution B. **Caution: To avoid damage to switch, do not immerse chute cover in solution. Wipe only with cleaning cloth.**
8. On units with beverage valves, remove nozzles and diffusers from valves, soak for at least 10 minutes in cleaning Solution A, rinse, sanitize with Solution B and reinstall.
9. For models with integral ice water bath beverage cooling only:
 - a. Lower Tygon drain tube found on drain connection side of waterbath into PVC waterbath drain and drain ice water bath.
 - b. Wash bath interior and components with Solution A, using a bottle brush to clean coils.
 - c. Reposition Tygon waterbath drain line in UP position.
 - d. Fill waterbath with Solution A and turn power back on.
 - e. Allow pump to run for 2 minutes to clean pump and pump lines.
 - f. Turn power OFF, drain bath and secure tube in UP position.

Putting unit back in service after quarterly cleaning

1. On units with integral beverage cooling, fill ice water bath manually with potable water. Add ice slowly enough to avoid spillage over top of waterbath.
2. Reassemble components.
3. For manual load units, turn dispenser power switch to ON position and fill unit with approved ice (see caution statement page 2).
4. For automatic load units, turn bin signal switch(es) and dispenser power switch to ON position and allow storage area to fill.
5. When dispenser has at least 6" (153mm) of ice in lower storage area, press dispense button or lever to test that dispenser is functioning properly.

Quarterly cleaning of icemaker system



Units with an icemaker require that icemaker be cleaned at least every three months or more often if local water conditions dictate. Failure to clean icemaker system will result in decreased performance and potential damage to icemaker. Refer to Icemaker Operation and Service Manual for instructions.

Disassembly instructions for periodic cleaning

Dispense chute cover removal

1. Remove dispenser top cover and turn three switches on electrical box OFF.
2. Remove two Phillips head screws from top of black dispense chute cover.
3. Pull chute cover forward and down to remove.
4. On push-button actuated units, disconnect plug on harness.

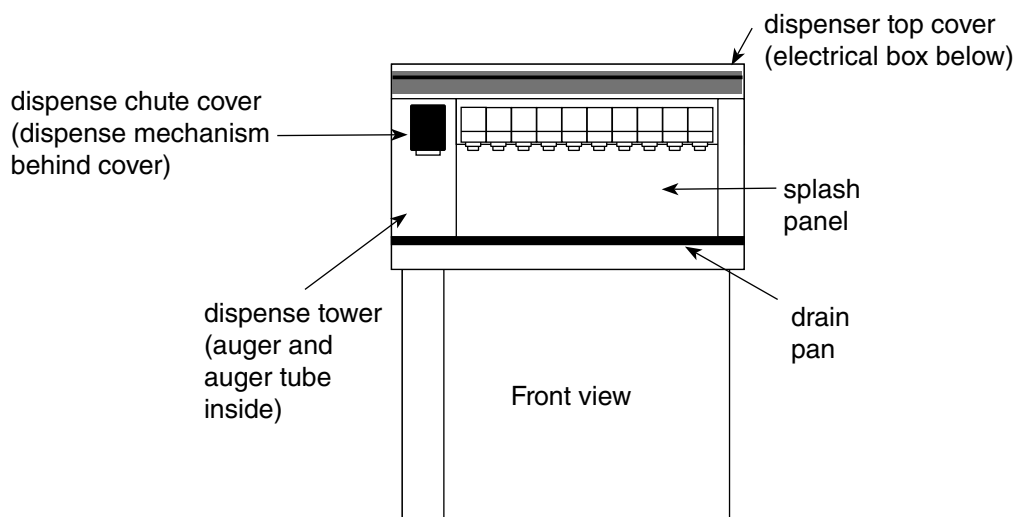

Gate assembly removal

1. Remove black dispense chute cover.
2. Remove thumbscrews on each side of focus chute and remove.
3. Remove quick release pins holding dispense gate assembly and chute.
4. Lift gate up and over hinge tabs, then carefully pull and tilt to unhook from solenoid link.
5. Pull ice chute toward you to unclip from dimples on chute mounting bracket.
6. Pull ice chute and gate toward you and out through panel opening.

Dispense chute assembly

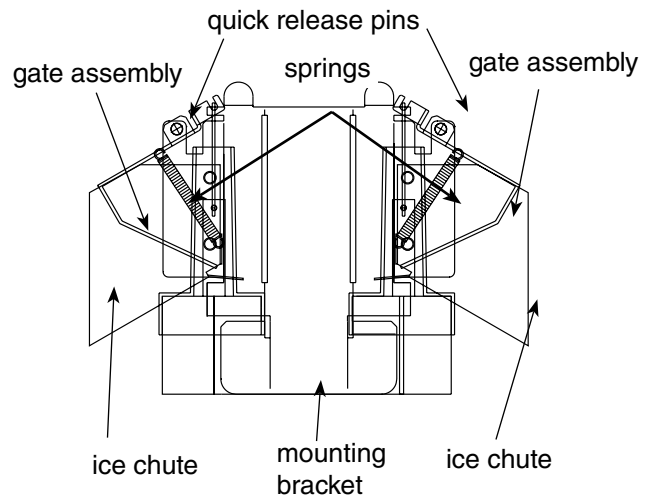

Auger and auger tube removal

1. Remove black dispense chute cover, focus chute, dispense chute and gate assembly.
2. Remove drain pan.
3. Remove thumbscrews from splash guard and remove.
4. Remove thumbscrews from splash panel; lift and pull forward at base of panel and remove.
5. Unplug auger motor at electrical box.
6. Remove two 1/4-20 bolts holding auger motor to holddown bracket.
7. Remove two thumbscrews from auger motor stabilizer bracket and aside.
8. Lift auger motor off.
9. Remove dispense chute mounting bracket assembly.
10. Remove side panel of tower.
11. Remove screw holding top auger tube ring to lower ring.
12. Lift auger out of auger tube.
13. Lift out auger tube, turning as needed to clear rivnuts on side auger motor mounting bracket.

U300 cutaway – front view

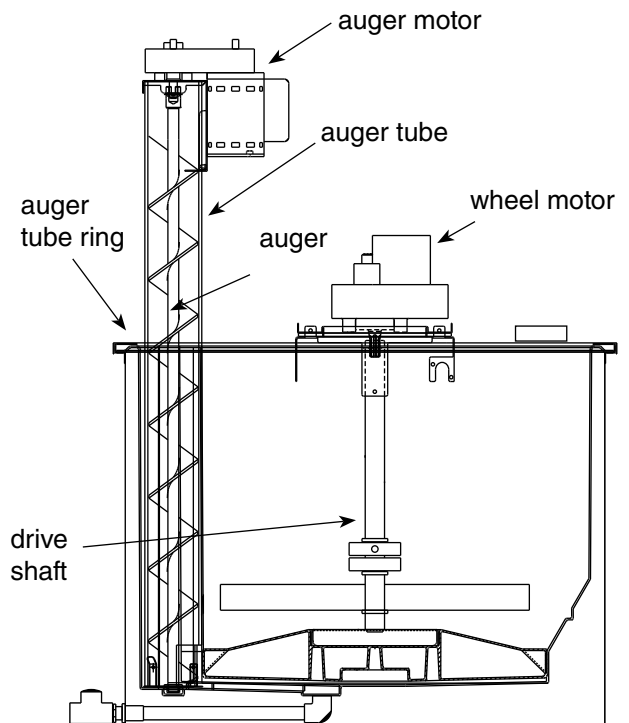

Front

Dispenser wheel removal

1. Remove dispenser top and turn power switch OFF.
2. Remove drain pan and ice bin access cover below it.
3. Remove splash guard and wheel motor access cover.
4. Remove all ice from bin.
5. Unplug wheel motor at electrical box and remove ground wire.
5. Remove wheel motor by pulling out two quick release pins.
6. Lift drive shaft up through hole in countertop.
7. Lift dispense wheel out through drain pan opening.

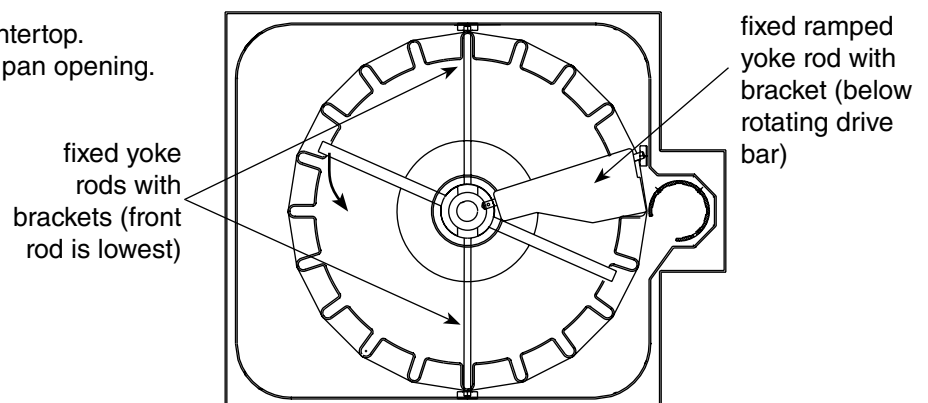

Wiring diagram

Single-sided models with a service number of 5012607 or higher or any model with **BLUE** circuit board

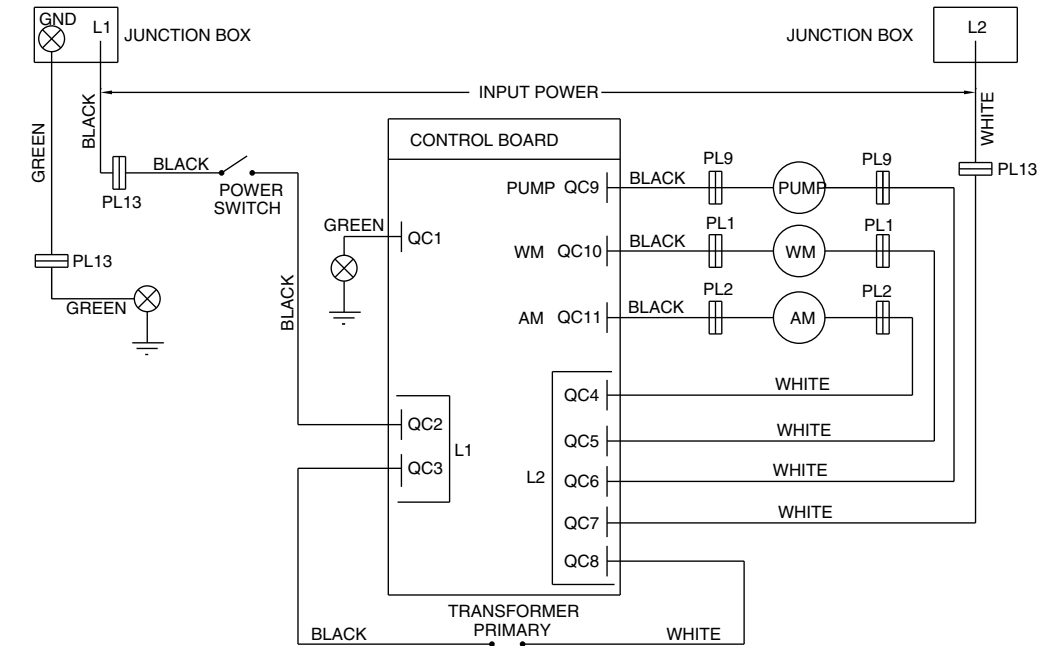

LEGEND	
AM AUGER MOTOR
DISP	... DISPENSE
GND	... GROUND
IM	... ICE MAKER
JB	... JUNCTION BOX
PB	... PUSH BUTTON
PL	... PLUG
QC	... QUICK CONNECT
SOL	... SOLENOID
TRAN	... TRANSFORMER
T'STAT	... THERMOSTAT
WM	... WHEEL MOTOR

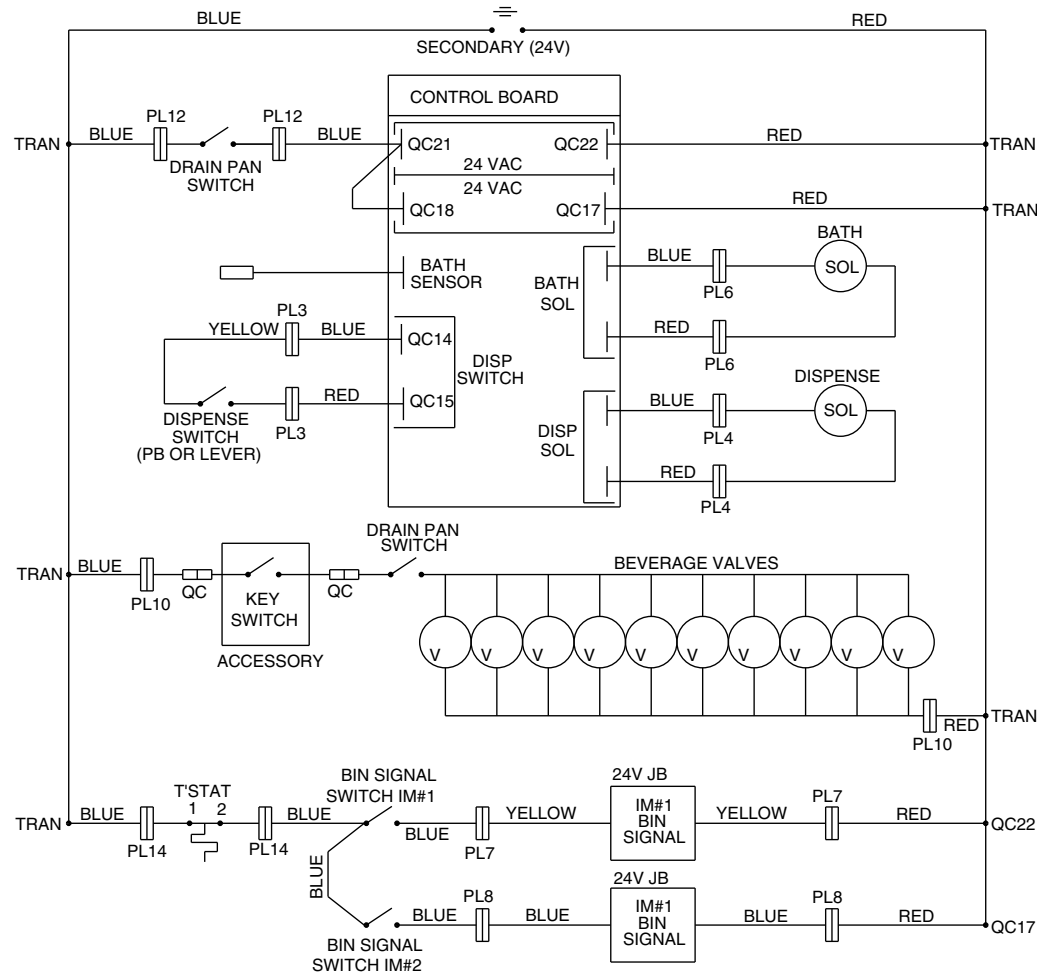

Temperature lights

Temperature lights provide information on the status of the ice-waterbath. When lighted, the following LEDs indicate:

Low LED: Bath is at optimal temperature for cold drinks.

High LED: Bath temperature is above optimal temperature. The bath will fill with ice for 15 seconds and will then stop for 75 seconds. If temperature is still too high, cycle will repeat.

Error and Low LEDs: After 15 minutes of fill cycling, bath is above 40°F (4.4°C).

Error (flashing) LED: Board not receiving signal from sensor.

Wiring diagram – all dual-sided models

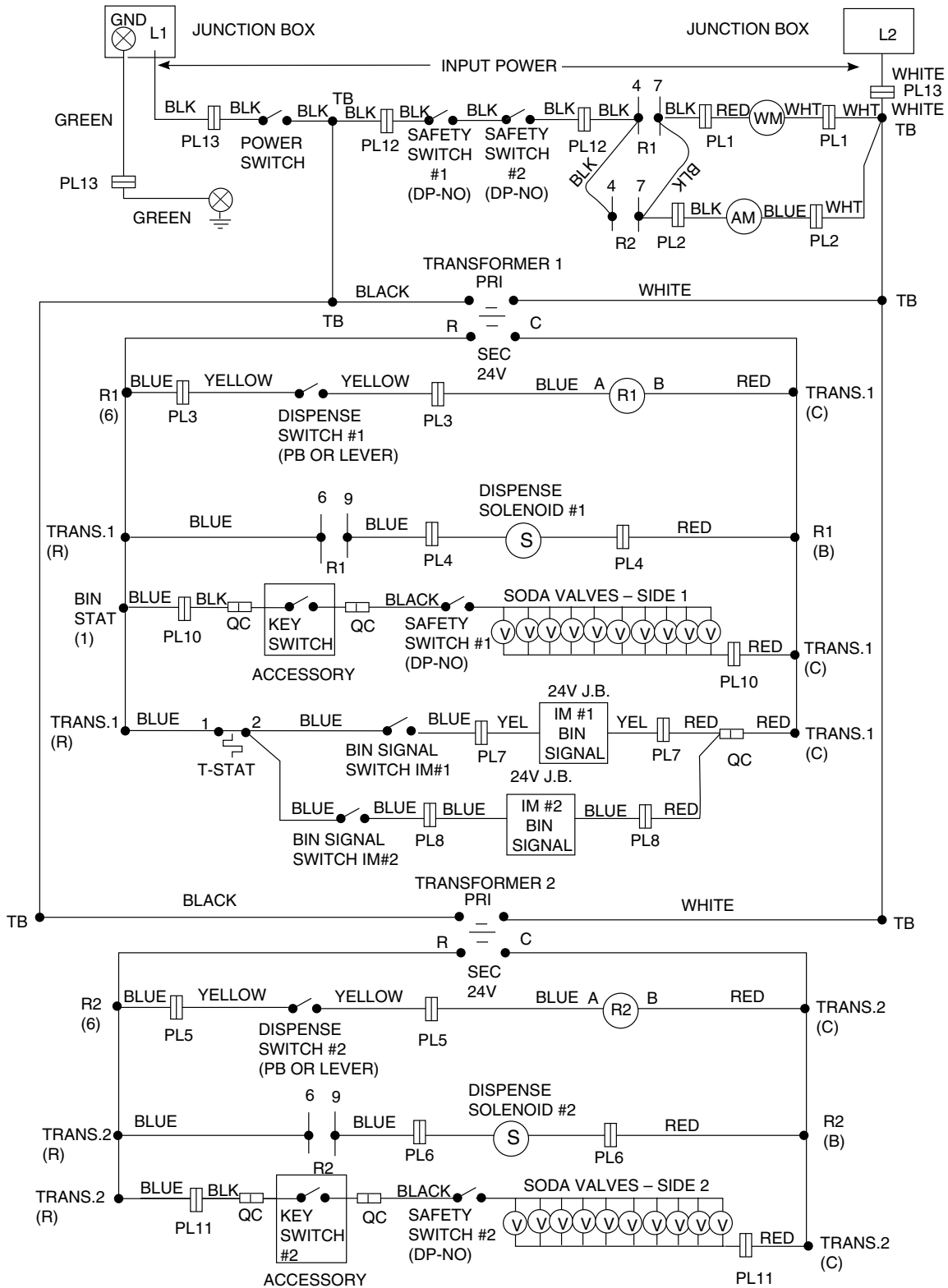

Service and parts

Before calling for service

1. Check that ice is in the dispenser and that congealed cubes are not causing a jam.
2. Check that circuit breaker and switches are in ON position.
3. Check that drain pan(s) are on securely. If ajar, neither dispenser nor valves will operate.
4. Check that all drains are clear.

For units equipped with Follett compressed nugget icemaker, see Icemaker Operation and Service Manual for service and troubleshooting information.

Dispenser troubleshooting guide

Symptom	Possible cause	Solution
Ice does not dispense when switch is actuated. <ul style="list-style-type: none"> • Auger motor does not run • Wheel motor does not run • Gate does not open 	<ol style="list-style-type: none"> 1. Power switch faulty or in OFF position; loose connection. 2. Faulty dispense switch. 3. Faulty transformer/tripped breaker. 4. Faulty fill board. 5. Drain pan ajar. 6. Faulty drain pan safety switch. 	<ol style="list-style-type: none"> 1. Turn power switch to ON, check connections. 2. Replace switch. 3. Replace transformer/reset breaker. 4. Replace fill board. 5. Check pan and reseal. 6. Replace switch.
Ice does not dispense. <ul style="list-style-type: none"> • Auger motor runs • Wheel motor runs • Gate does not open 	<ol style="list-style-type: none"> 1. Loose electrical connection. 2. Linkage problem between solenoid and gate. 3. Faulty solenoid. 4. Faulty fill board. 	<ol style="list-style-type: none"> 1. Check connections. 2. Check linkage. 3. Replace solenoid. 4. Replace fill board.
Ice does not dispense. <ul style="list-style-type: none"> • Auger motor does not run • Wheel motor runs 	<ol style="list-style-type: none"> 1. Loose electrical connection. 2. Faulty auger motor. 3. Faulty run capacitor. 	<ol style="list-style-type: none"> 1. Check connections. 2. Check auger motor. 3. Check run capacitor.
Ice does not dispense. <ul style="list-style-type: none"> • Auger motor runs • Wheel motor does not run 	<ol style="list-style-type: none"> 1. Loose electrical connection. 2. Faulty wheel motor. 3. Faulty run capacitor. 	<ol style="list-style-type: none"> 1. Check connections. 2. Check wheel motor. 3. Check capacitor.
Warm drinks or soda foaming.	<ol style="list-style-type: none"> 1. No ice in storage bin. 2. Water drained out of ice-waterbath. 3. Faulty circulating pump. 4. Faulty bath solenoid. 5. Faulty thermistor. 	<ol style="list-style-type: none"> 1. Fill storage area with ice or check icemaker operation. Push reset on board. 2. Check that ice-waterbath drain tube is in fixed upright position. Push reset on board. 3. Check pump. Push reset on board. 4. Replace bath solenoid. Push reset on board. 5. Replace thermistor.

If problem persists after following this basic troubleshooting guide, call Follett's technical service department at (800) 523-9361 or (610) 252-7301.

Symptom	Possible cause	Solution
Beverage valves not operating.	<ol style="list-style-type: none"> 1. Faulty 24V transformer. 2. Power switch faulty or in OFF position. 3. Drain pan switch faulty or not depressed. 4. Beverage key switch locking out access. 	<ol style="list-style-type: none"> 1. Check transformer & circuit breaker. 2. Check power switch. 3. Check switch and placement of drain pan. 4. Check valve lockout.
Ice dispenses without actuation.	<ol style="list-style-type: none"> 1. Front ice gate stuck open. 2. Faulty rear solenoid. 3. Faulty pump/faulty bath temperature sensor. 4. Linkage pin dislodged or broken. 5. Ice jam in rear chute. 6. Misplaced bath sensor causing jam of rear chute. 7. Wire off rear solenoid causing ice to dispense out front when filling bath, without actuation. 	<ol style="list-style-type: none"> 1. Adjust gate (contact Follett) 2. Replace solenoid. 3. Replace pump or bath sensor. 4. Check pin and reseal or replace if broken. 5. Clear ice jam from chute. 6. Remount bath sensor in proper location. 7. Reconnect wire.
No ice in dispenser.	<ol style="list-style-type: none"> 1. Power switch in OFF position or faulty. 2. Bin signal switches in OFF position or faulty. 3. Faulty bin thermostat. 4. Faulty transformer. 5. Icemaker related problem. 6. Faulty or disconnected wiring. 	<ol style="list-style-type: none"> 1. Check switch and replace if necessary. 2. Check switch and replace if necessary. 3. Replace bin thermostat. 4. Replace transformer. 5. Refer to icemaker Operation and Service Manual for diagnosing. 6. Check for power and bin signal on icemaker pc board.

Disassembly instructions for service requirements only – NOT required for any cleaning procedure.

Ice water bath pump motor removal

1. Disconnect electrical wires to pump.
2. Remove two screws anchoring pump motor bracket to water bath.
3. Loosen hose clamp on 1" (26mm) Tygon hose at pump and pull hose free of pump motor.
4. Slide motor and bracket toward center of dispenser and lift to remove.

Plan view ice water bath

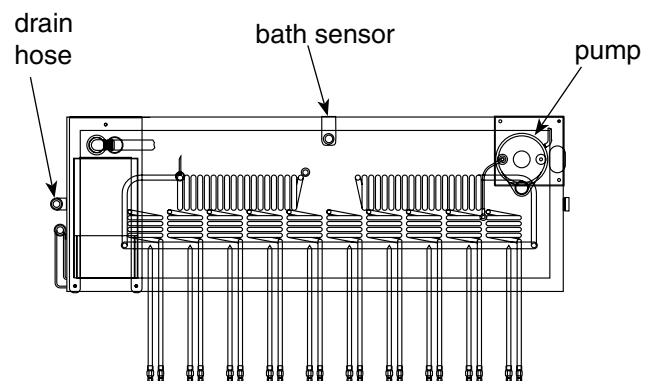

Parts

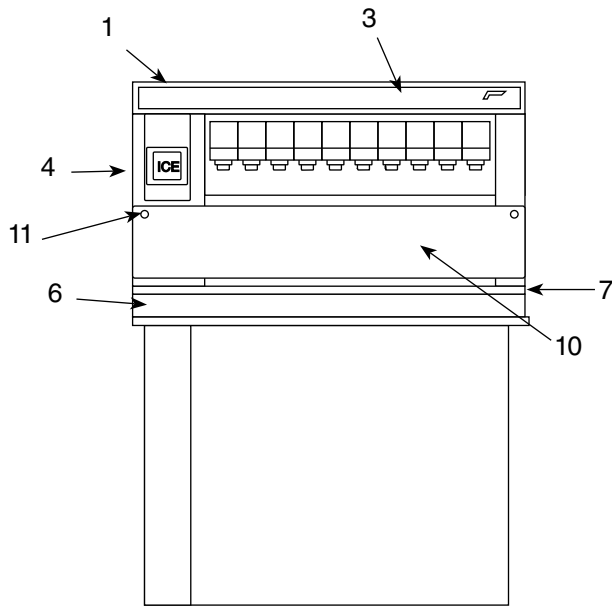

Single-side dispenser

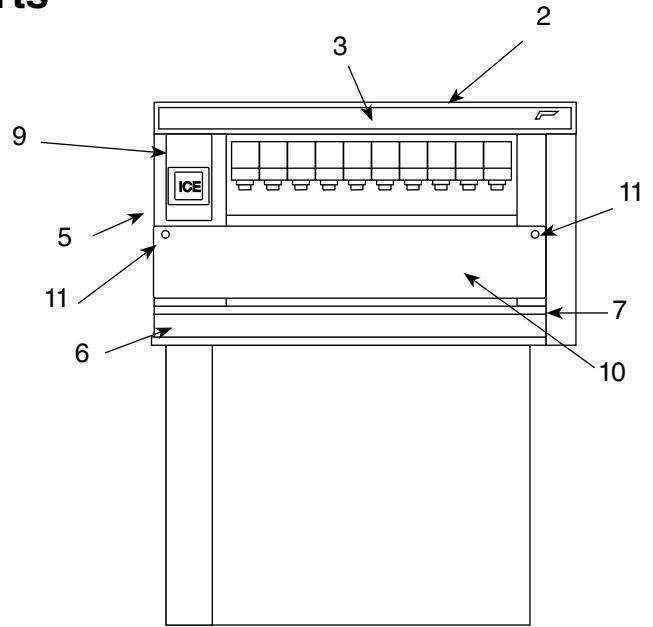

Dual-side dispenser

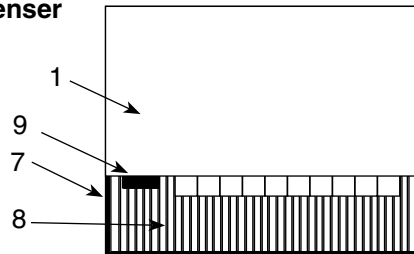

Plan view

Reference #	Description	Part #
1	Lid, with graphics, single-sided	501930
2	Lid, with graphics, dual-sided	501931
3	Graphics, "Follett"	501938
4	Access panel, tower, single-sided	501944
5	Access panel, tower, dual-sided	501945
Not shown	Cover, ice opening (below drain pan)	501934
6	Drain pan assembly and grille	501935
7	Drain pan, plastic	501936
Not shown	Switch, drain pan safety	501318
8	Grille, drain pan	501937
9	Chute cover, dispense, push-button with switch	501957
Not shown	Chute cover, dispense, lever	501956
10	Splash guard	501943
11	Thumbscrew, 10/32-1/2, splash guard	501100
Not shown	Switch, dispense, PB	502441
Not shown	Switch, dispense lever (includes boot and spacer)	501714
Not shown	Boot, dispense switch button, lever	501841
Not shown	Access cover, wheel motor (behind splash guard)	501932
Not shown	Skid	501946
Not shown	Carton and fillers	501947
Not shown	Lip kit (plastic strip bordering ice bin opening and adhesive)	502285
Not shown	Insulation, transport tube (sold by the foot)	501176
Not shown	Tube, ice transport, 10 ft	502522
Not shown	Tube, ice transport, 20 ft	502523
Not shown	Plug 2 lead, male	502333
Not shown	Plug 2 lead, female	502334

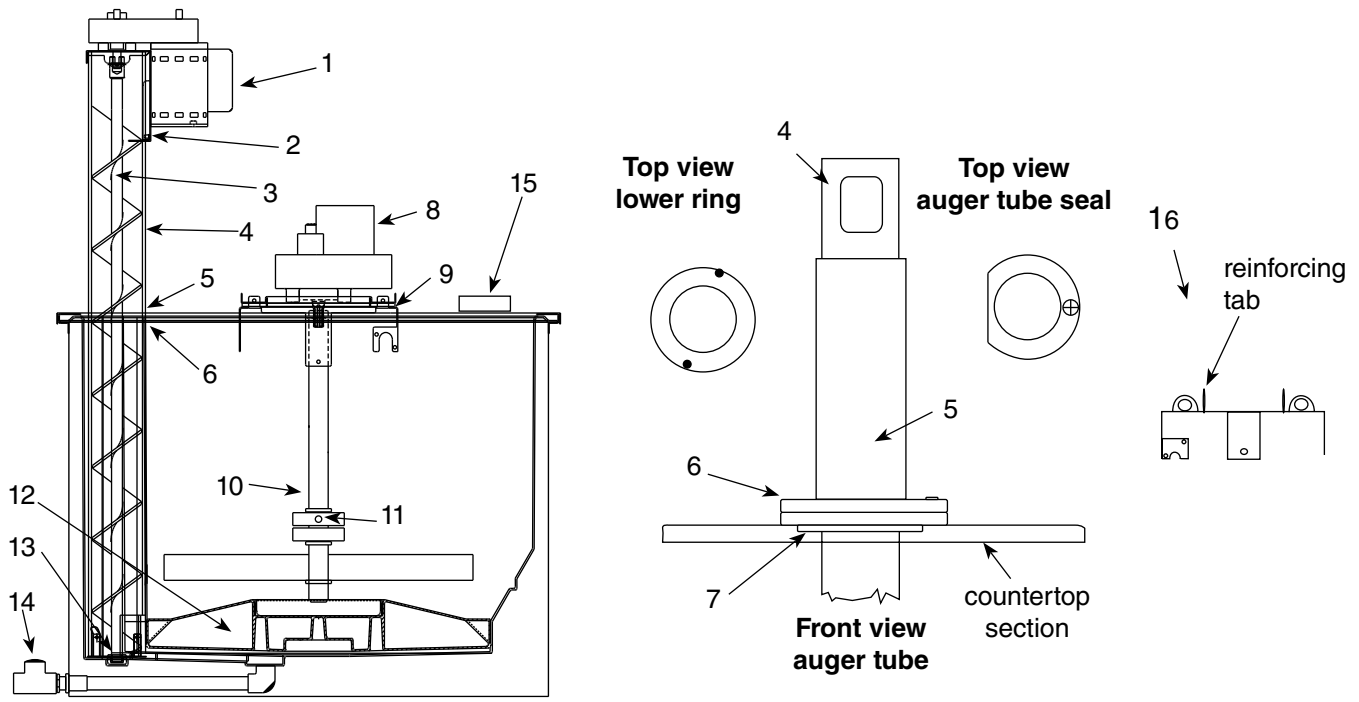

Reference #	Description	Part #
1	Motor, auger (includes capacitor), 100 RPM*	00918904
2	Bracket, auger motor hold-down	502047
Not shown	Bracket, auger motor stabilizer, single-sided models	502060
Not shown	Bracket, auger motor stabilizer, dual-sided models	502113
Not shown	Seal, shaft, auger motor	501977
3	Auger	501980
4	Auger tube (includes insulation)	502631
5	Insulation, auger tube	502099
6	Ring, auger tube, upper	501939
7	Ring, auger tube, lower	502155
8	Motor, wheel, Brother (includes capacitor)	502657
9	Bracket, wheel motor	501981
Not shown	Capacitor, wheel motor, Brother	502658
Not shown	Gasket, wheel motor bracket	501982
Not shown	Pin, quick release, wheel motor (2 required)	502102
10	Drive shaft assembly, for Brother motor	502630
11	Agitator rods, fixed, front and back	502629
12	Wheel, dispense	501978
13	Bearing plate, bottom auger	501971
Not shown	Bearing, bottom, auger	501972
Not shown	Agitator rod, ramped	502628
Not shown	Bracket, fixed agitator (3 used per unit)	501974
Not shown	Thumbscrew, 10/32 x 3/4, fixed agitator bracket (2 required)	501259
14	Tee, drain	502059
15	Thermostat box (includes 500514)	502211
Not shown	Thermostat	500514
Not shown	Retainer, ice hose (includes 2 thumbscrews)	501764
16	Bracket, ice hose and wheel motor	502050

**U300 dispense assembly
side view**

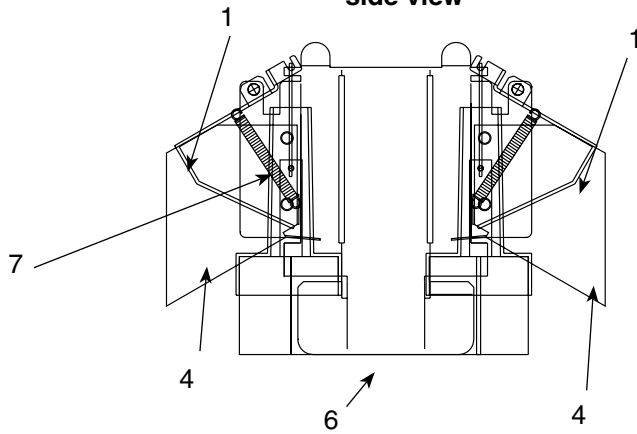

**U300 dispense assembly
top view**

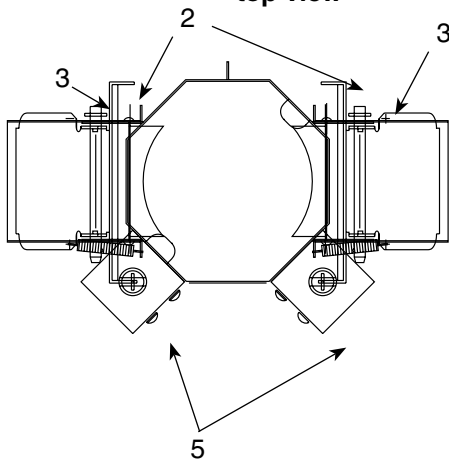

Reference #	Description	Part #
1	Gate, dispense	501955
2	Linkage pin, gate/solenoid	502096
3	Pin, quick release, 3" (77mm), gate and lever	501949
4	Chute, ice	501952
5	Solenoid	501961
Not shown	Boot, solenoid	502098
6	Dispense mechanism assembly	501948
7	Spring, dispense mechanism (1 per side)	501950
Not shown	Chute, focus	501954
Not shown	Lever, dispense	501953

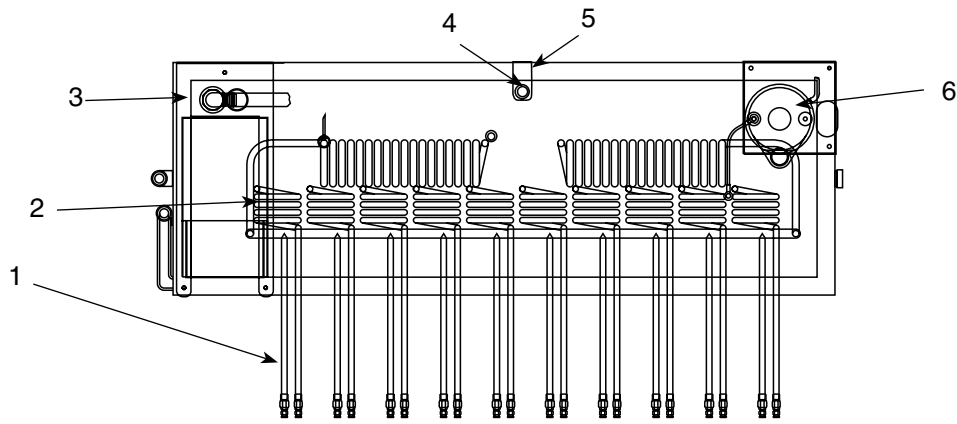

Reference #	Description	Part #
1	Manifold, carbonated water (bev. cooled units)	502002
2	Syrup coil	501962
3	Waterbath ice guide assembly	502001
4	Bath sensor	502208
5	Bracket, bath sensor	502210
6	Pump, waterbath	501964
Not shown	Manifold, carbonated water (single-side, non-beverage cooled units)	501968
Not shown	Tubing, vinyl, 1/2" (13mm) ID x 5/8" (17mm) OD (order by the foot – 5 feet required for bath, 2 feet required for overflow)	501965
Not shown	Tubing, vinyl, pump (order by the foot – 3 feet required)	501966
Not shown	Syrup tube, insulated, non-bev. cooled units)	501967
Not shown	Cap, carbonated water manifold valve fitting	502062

Electrical box

Single-sided models with BLUE circuit board

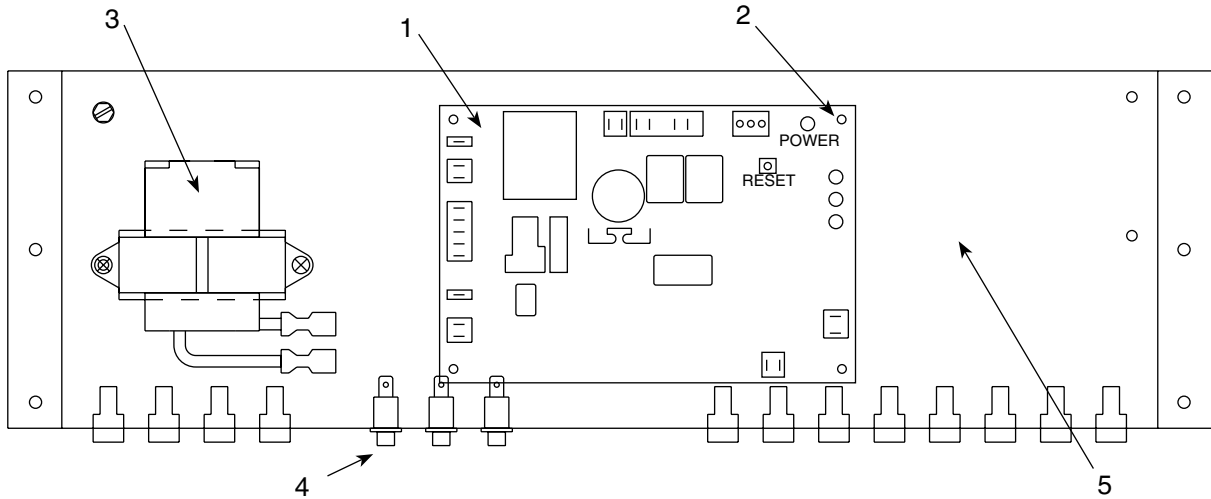

Reference #	Description	Part #
1	Control board (blue)	502207
2	Stand-off	501959
3	Transformer, 65VA	502058
4	Switch, rocker	502209
5	Control box (includes all components)	502212
Not shown	Keylock switch with leads	501960
Not shown	Bracket, electric box support	501933
Not shown	Thermostat (located behind splash panel in thermostat box)	500514
Not shown	Key, beverage, lock switch	501286

Electrical box

All UD300 dual-sided models

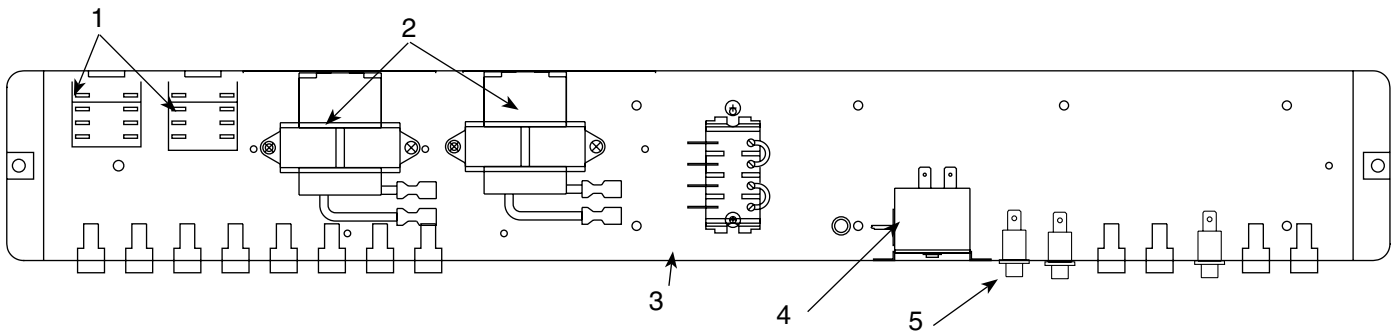

Reference #	Description	Part #
1	Relay, 24V	501826
2	Transformer, 65VA	502058
3	Control box, dual-side models	502049
4	Thermostat	500514
5	Switch, rocker	502209
Not shown	Bracket, electric box support	502113
Not shown	Keylock switch with leads	501960
Not shown	Key, beverage, lock switch	501286