



FOOD WARMING EQUIPMENT

OPERATING INSTRUCTIONS



HEATED HOLDING COMPANION

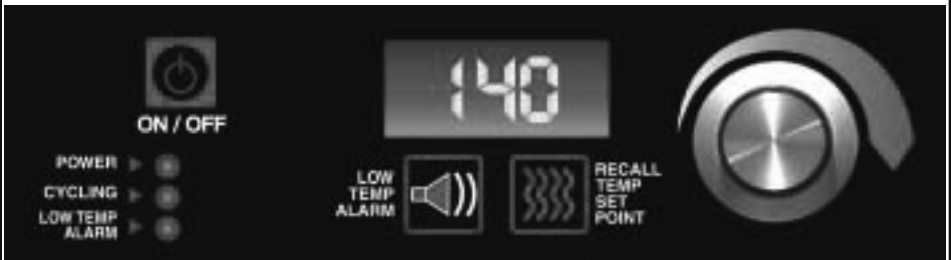

“HHC” SERIES

HEATED HOLDING
COMPANION CABINET

FWE HEATED HOLDING COMPANION



HHC-CC-MW

*Shown with Rational® Rack
(Not included.)*

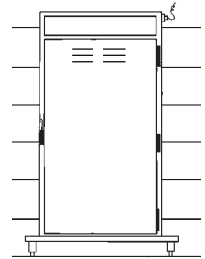

HHC-CC

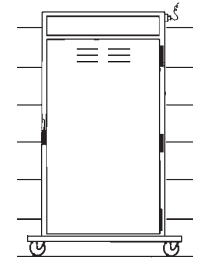

HHC-CC-MW

CONGRATULATIONS...

...and thank you for purchasing an FWE COMBI-COMPANION or FWE HEATED HOLDING COMPANION heated holding cabinet. Your unit has been designed and manufactured under rigid controls to assure you the most efficient service. It is a full time unit, and may be used continuously.

Please take a moment to read through this booklet of important information pertaining to your cabinet. By following a routine of proper use and care described on the following pages, your cabinet will last for many years.

IMPORTANT: Your **Manufacturer Registration Card** must be returned within 30 days after initial delivery to activate the warranty.

CAUTION: HOLDING FOOD AT TEMPERATURES OF LESS THAN 140°F MAY BE DANGEROUS. TEMPERATURES UNDER 140°F PROMOTE THE GROWTH OF HARMFUL BACTERIA AND TOXINS IN SOME FOODS.

QUICK-START GUIDE



On/Off Switch -

- A.) Turns cabinet on and off.
 B.) °Celsius and °Fahrenheit Scale: You may change the Digital thermometer scale to either °C or °F as follows: While unit is "Off", press and hold the "ON/OFF" key for five (5) seconds. The display will then switch from "dgF" to "dgC". Repeat to change scale again.



Power Indicator Light -

Indicates that the power is on.



Dial -

Use dial to set the desired temperature. Dial rotates completely.



Temp Display -

Digital temperature display:

- A.) °Celsius and °Fahrenheit Scale: You may change the Digital thermometer scale to either °C or °F as follows: While unit is "Off", press and hold the "ON/OFF" key for five (5) seconds. The display will then switch from "dgF" to "dgC". Repeat to change scale again.
 B.) Unit may be set to show either actual internal temperature, or "Set Point Temperature". (See "Recall Temp Set Point")



Cycling Indicator Light -

When light is "ON", this indicates that the cabinet is warming up to desired temperature. When heating elements are activated, light will come "ON" until cabinet has reached desired temperature, and go "OFF" when unit has reached desired temperature.

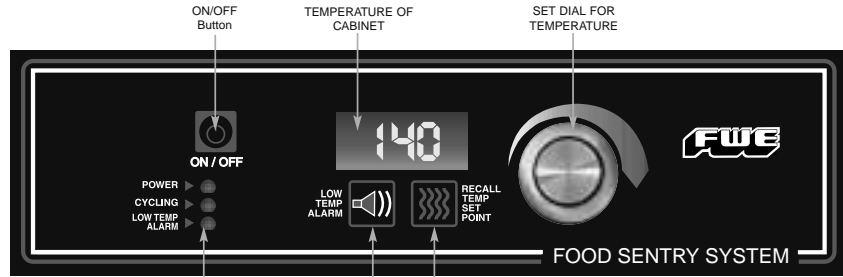

Recall Temp Set Point -

Unit may display either "Actual Internal Cabinet" actual temperature, or desired "Set Point" temperature.

Actual: The factory default setting shows the actual internal cabinet temperature and acts as a digital thermometer. A momentary touch of the "Recall Temp Set Point" key will recall the original dial setting. The display will then automatically return to the actual internal temperature.

Set Point: To have temperature read-out display the "Set Point" temperature, press and hold the "Temp" key for five (5) seconds. The fourth (4th) digit on the display will flash either "S" (Set), or "A" (Actual) to indicate which mode is active. To switch back again, repeat this step holding the "Recall Temp Set" key for five (5) seconds.



Low Temp Alarm -

NOTE: THE FACTORY DEFAULT FOR THIS FEATURE IS IN THE "OFF" OR DISABLED MODE.

Unit has a built in "Low Temp" alarm, allowing the operator to have an audible and a visual indicator that the heated cabinet has dropped below the "Low Temperature" set point for more than two (2) minutes.

- 1.) Adjust Set Point:** Press and hold "Low Temp Alarm" key. While holding, rotate dial to desired set point between "OFF" and from 90°F (32°C) and 190°F (88°C). Release button to accept adjustments. When the internal cabinet temperature falls below this "Set Point" for more than two (2) minutes, the audible and visual alarm will alert you to this condition.
- 2.) Recall Set Point:** Press "Low Temp Alarm" key to recall setting. The display reverts back to the normal display after three (3) seconds.
- 3.) Acknowledge:** Press any key to cancel beeping and flashing LED. The LED remains lit until the temperature rises above the alarm set point.
- 4.) Disable:** Follow the adjustment steps above. A rotation of the dial "down" below 90°F (32°C) turns the alarm feature off.



Low Temp Alarm Indicator Light -

The "Low Temp Alarm" light will blink while setting the "Low Temp Set Point". When the temperature falls below the "Low Temp" set point, the indicator light will blink until the alarm is cancelled/acknowledged. The light will remain illuminated until the interior cabinet temperature reaches above the "Low Temp Set Point" again.



Food Warming Equipment Company
 7900 South Route 31
 Crystal Lake, Illinois 60014

Phone: 815-459-7500
 Fax: 815-459-7989
 sales@fweco.com

FWE FOOD SENTRY HEATED COMPANION

INSTALLATION AND CARE

SERIAL AND MODEL NUMBER

These numbers are found on the nameplate (serial tag) affixed to the unit by the electrical cord. Please record them in this booklet, in the space provided on page 9. When ordering parts and/or service, you will need to provide this information. The voltage and amperage of the unit are also stamped on the serial tag.

UNPACKING

After uncrating your cabinet, remove all tape and padding which held all doors, shelves, racks, cord, etc., in place during shipment.

ELECTRICAL REQUIREMENTS AND GROUNDING

FWE standard models operate on 110/120 volt, 60 Hz, 1 ph, A.C. (unless ordered otherwise), and are equipped with a three prong grounding cord plug for your protection against possible shock hazards. Be sure to plug only into a properly grounded three prong wall receptacle. If you have any questions with regard to adequate wiring or grounding in your building, a qualified electrician should be contacted before using your cabinet. The amperage of your cabinet is stamped on the name plate attached to the unit.

DO NOT, UNDER ANY CIRCUMSTANCES, CUT OR REMOVE THE GROUNDING PRONG FROM THE CORD PLUG.

WARNING: ONLY A QUALIFIED ELECTRICIAN SHOULD ATTEMPT TO REPAIR OR REPLACE ELECTRICAL COMPONENTS OR WIRING.

BE SURE THAT MODEL IS UNPLUGGED FROM ELECTRICAL SOURCE BEFORE REMOVING CONTROL PANEL.

CLEANING

Keep your cabinet clean by simply wiping the interior and exterior, as needed, with a damp cloth or sponge and a mild soapy solution.

NEVER USE ABRASIVES, ACIDS, OR STRONG CLEANERS.

Do not flood or allow electrical parts to become wet. The interior tray slide assemblies and humidifier pans are removable for easy cleaning. A stainless steel cleaner/polish is recommended for the exterior to maintain a "like-new" appearance.

DO NOT USE WAX OR STRONG CLEANERS ON DOOR GASKETS OR VINYL TRIM.

FOOD SENTRY CONTROLS

The control panel, recessed at the top of the unit above the door, is equipped with an adjustable thermostat (to 190°F) for temperature selection, a digital thermometer to show the actual internal temperature of the cabinet, ON/OFF switch, a red power indicating light to tell you when the cabinet is on, and an indicating light which illuminates when the heating element is activated and cycling.

Recall Temp Set Point -

Unit may display either *"Actual Internal Cabinet"* actual temperature, or desired *"Set Point"* temperature.

Low Temp Alarm -

Unit has a built in *"Low Temp"* alarm, allowing the operator to have an audible and a visual indicator that the heated cabinet has dropped below the *"Low Temperature"* set point for more than two (2) minutes.

NOTE: THE FACTORY DEFAULT FOR THIS FEATURE IS IN THE "OFF" OR DISABLED MODE.

GENERAL OPERATING INSTRUCTIONS

PREHEAT CABINET BEFORE LOADING HOT FOOD

1) PLUG CABINET INTO A PROPERLY GROUNDED POWER RECEPTACLE. Press ON/OFF icon. The power indicating light will come on and remain on until ON/OFF icon is pressed again, or the unit is unplugged.

2) SELECT A TEMPERATURE SETTING. For most foods, a holding temperature of 150° - 160°F should be adequate.

3) FOR BEST RESULTS, PRE-HEAT CABINET FOR AT LEAST 30 MINUTES, HEATING UP THE INTERIOR STAINLESS STEEL WALLS.

When the cycling light goes off, the cabinet “air” has reached the temperature which you selected in step 2. By pre-heating cabinet at least 30*minutes, even after the cycling light has gone off, you are heating up the stainless steel wall interior. This retains cabinet heat for faster recovery times.

By thoroughly pre-heating the unit before each use, you heat up the interior stainless steel and obtain the best holding results from your cabinet.

4) LOAD THE CABINET with your Combi or Steamer Mobile Plate Rack. After loading is completed, do not open doors again until you are ready to serve.

**DO NOT PUT COLD FOODS
INTO A HOT CABINET!**

GENERAL OPERATING INSTRUCTIONS

PUT HOT FOOD INTO A HOT CABINET

5) TRANSPORTING HOT FOODS. Mobile cabinets are equipped with a positive transportation latch to assure safety during transportation. Before moving the cabinet, keep it plugged in and wait until the red cycling light goes off. This recovery takes only a short time, and allows the internal temperature to again reach the setting you have selected. As soon as the cycling light goes off, unplug the cabinet and wheel to serving area. Plug the cabinet into an electrical outlet at the serving location (if available), so that the thermostat will re-activate and automatically hold your pre-selected temperature.

6) STATIONARY CABINETS WITH LEGS. NOTE:

Adjustable legs mounted to cabinet may need height adjustment upon delivery prior to cabinet usage. Proper **height of cabinet** is critical to achieve proper docking of rack. Optimum space tolerance is necessary to allow for heat expansion, preventing scaring and scratches to cabinet or damage to rack. Adjustment to cabinet legs is accomplished easily with cabinet upright by turning the tapered floor tip of each leg clock-wise (to the left) to raise cabinet; counter-clockwise (to the right) to lower cabinet.

SET-UP PRIOR TO OPERATION.

PARTS LIST

FIVE PARTS DEPARTMENT: 815 459 7500

REPLACEMENT PARTS

Knob for thermostat
 Push handle, aluminum bar, 12.5"
 Push handle, aluminum bar, 21.5"
 Spacers for push handles
 Bolts, hex head for handles
 Door Latch - Chrome Magnetic
 Bumper insert, black vinyl
 Extension Cord 10 ft. Plug: 5-15P
 Extension Cord 10 ft. Plug: 5-20P
 Casters: 5" rigid
 Casters: 5" swivel with brake
 Tray slides, pair (TST models)
 Tray slides, pair (UHST models)
 Shelves: Sized by Model Number

PART NUMBER

KNB H7
 HDL 12.5 AL
 HDL 21.5 AL
 SPCR125x.330
 B1/4-20x32NZ
 LTH MAG
 BMPR INSERT
 CRDSET10/115
 CRDSET20/115
 CSTR 5 R-2
 CSTR 5 SB-2
 SLD TS245
 SLD UHS245
 Consult Factory

Other Replacement Parts are available. Your Model Number and Serial Number are required when requesting Parts or Service. These numbers are listed on your Serial Tag located by the power cord.

TROUBLE-SHOOTING CHART

Check this list first before you call for service...

<p>TEMP NOT HOT ENOUGH</p>	<p>1A] Opening door unnecessarily 1B] Thermostat set too low 1C] Cord plug pulled out from outlet 1D] Fuse blown - no power to outlet 1E] Pre-Heat Cabinet</p>	<p>1A] Heat escapes from cabinet when door is opened too frequently. 1B] Set thermostat at a higher temperature. 1C] Replug cord into proper outlet. 1D] Have a qualified electrician check power and fuse box. 1E] Assure interior of cabinet heats up, not just cabinet air temperature. Allow at least 30 minute pre-heat.</p>
<p>NO HEAT AT ALL</p>	<p>2A] Cabinet not plugged into outlet 2B] Cabinet power " OFF " 2C] Fuse Blown - no power to outlet 2D] Heating element needs replacing 2E] Control panel needs replacing</p>	<p>2A] Plug cabinet into properly grounded electrical outlet. 2B] Press power icon on the control panel 2C] Have a qualified electrician check power to fuse box. 2D] Heating element will either function or not function. Consult factory. 2E] Consult factory.</p>

FWE FOOD SENTRY HEATED COMPANION

WIRING DIAGRAM

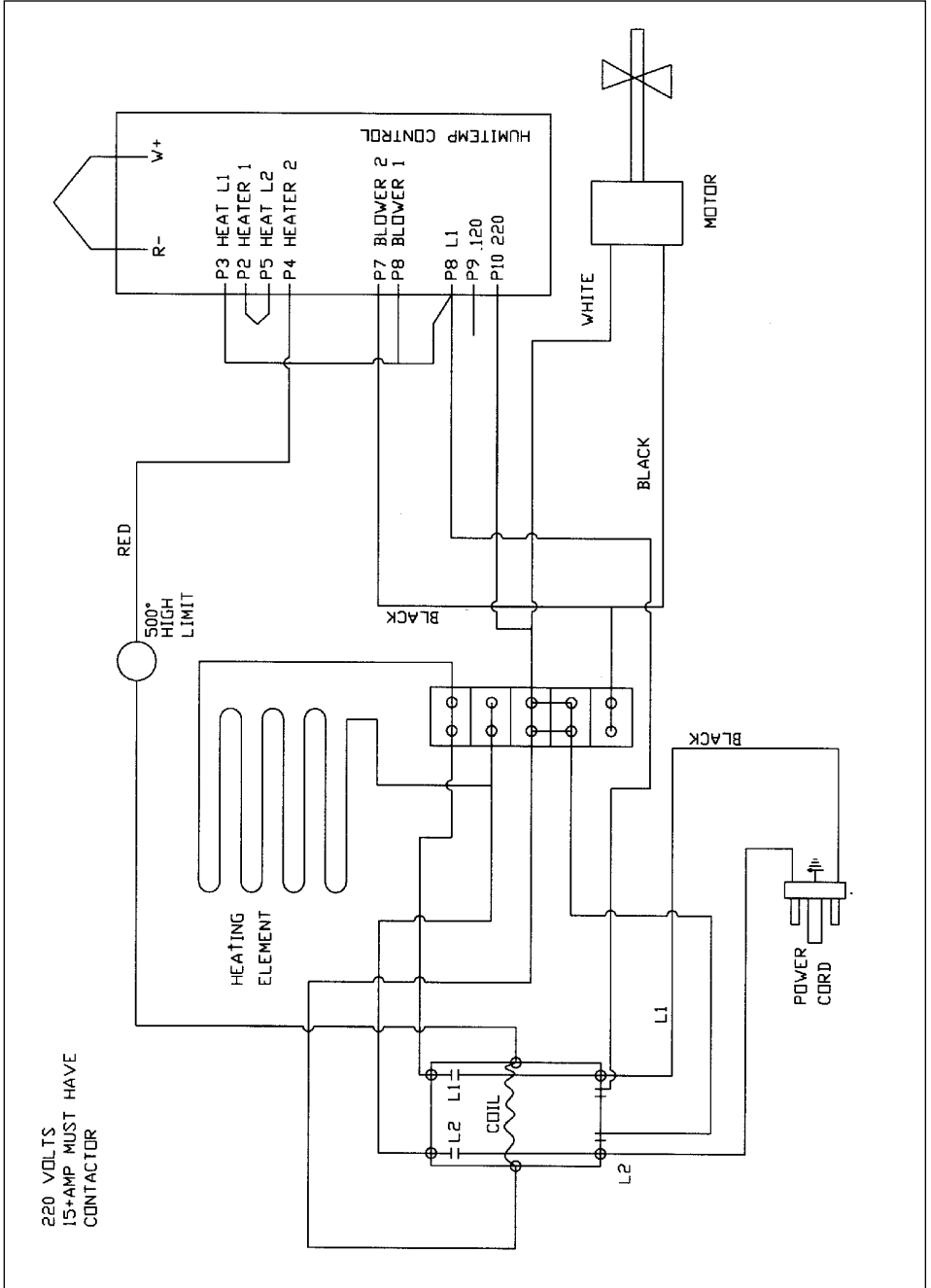

FWE FOOD SENTRY HEATED COMPANION

LIMITED TWO YEAR WARRANTY

FWE / Food Warming Equipment Company, Inc. (Seller) warrants to the original purchaser, subject to the exceptions and conditions below, that FWE manufactured equipment shall be free from defects in material or factory workmanship, under ordinary use for the purpose for which it is designed. The effective warranty period is as follows:

PARTS: Seller will furnish without charge to the original purchaser, FOB Sellers' factory, replacement parts for repairs to all new standard catalog products and factory custom / modified units, which in Seller's sole judgement, prove defective in materials or workmanship under normal and proper use with the reserved right to request the return of any part claimed to be defective, prior to issuing replacement part or authorizing warranty service, for a period of two (2) years from date of original shipment from Seller's plant, *except for equipment used in a **Correctional Environment / Facilities**, which is warranted for a period of one (1) year from date of original shipment from Seller's plant.*

LABOR: Seller's labor warranty shall be performed by a Seller-approved Service Agency who must contact Seller to obtain a Warranty Service Authorization (WSA) number prior to performing any repairs. If service is required during overtime periods, the difference between overtime and standard labor rates shall be paid by the purchaser. Seller does not assume any responsibility for any charges not expressly authorized, incidental to the repair or replacement of equipment covered by this warranty, nor charges exceeding, in Sellers sole judgement, normal and customary amounts. Only approved travel charges will be allowed. Seller's labor warranty shall be from the date of original shipment date from Seller's plant for a period of one (1) year, *except for equipment used in a **Correctional Environment / Facilities** which is warranted for a period of six (6) months.*

This warranty is for normal usage and does not apply to any product or parts thereof that have been misused, altered, or where Seller's operating instructions or specific voltage is not observed; nor shall this warranty apply to defective products or parts resulting from accident following date of original shipment, nor extend to or cover removal, installation, reinstallation or calibration, or service calls or cost of repairs undertaken by a customer. This warranty is also subject to the following:

- 1.] Customer returning the warranty registration card, accompanying Sellers original shipment, to Seller within thirty (30) days of receipt;
- 2.] Giving immediate notice of any allegedly defective part or product to Seller; and
- 3.] Customer, at Sellers request, returning said defective parts or product to Seller.

This is the sole warranty applicable to the merchandise. It is expressly understood that Seller's liability hereunder is limited to the repair or replacement, at Seller's option, of products or parts, defective materials or workmanship as provided above. Seller's judgement as to the cause and nature of any defect will be final. Seller shall in no case be responsible for special or consequential damages or any other obligation or liability with respect to products sold by Seller.

This warranty, as stated above, applies to equipment installed in the Continental United States. FWE equipment installed outside the Continental United States shall carry parts coverage only. All labor costs are approved on a discretionary basis, based on like repairs in the Continental U.S. This warranty shall stand in whole or in part as allowed by law. Any exclusion of a part of this warranty, as may be allowed by law, shall not void balance of warranty.

The best designed . . .
The best built . . .
The best performing units on the market!



- ◇ Retherm Cabinets
- ◇ Self-Propelled Transports
- ◇ Heated Banquet Cabinets
- ◇ Universal Bulk Food Cabinets



- ◇ Utility Carts
- ◇ Refrigerators, Freezers and Convertibles
- ◇ Prisoner & Correctional Tray Delivery

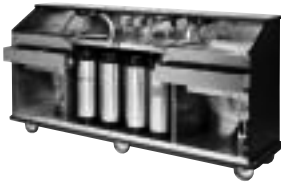

- ◇ Hospital Tray Delivery Carts
- ◇ Portable Bars and Back-ups

FWE[®]

WE OFFER SALES AND SERVICE WORLDWIDE

Food Warming Equipment Company, Inc.

P.O. Box 1001

Crystal Lake, IL 60039-1001

Manufacturing Facilities:

7900 S. Route 31

Crystal Lake, IL 60014

FWE Parts Department:

815 459 7500

Errors subject to correction. All specifications
subject to change without notice.
© 08 Food Warming Equipment Company, Inc.

FAX:

815 459 7989