

MODEL:

P-200-2

Parts Manual

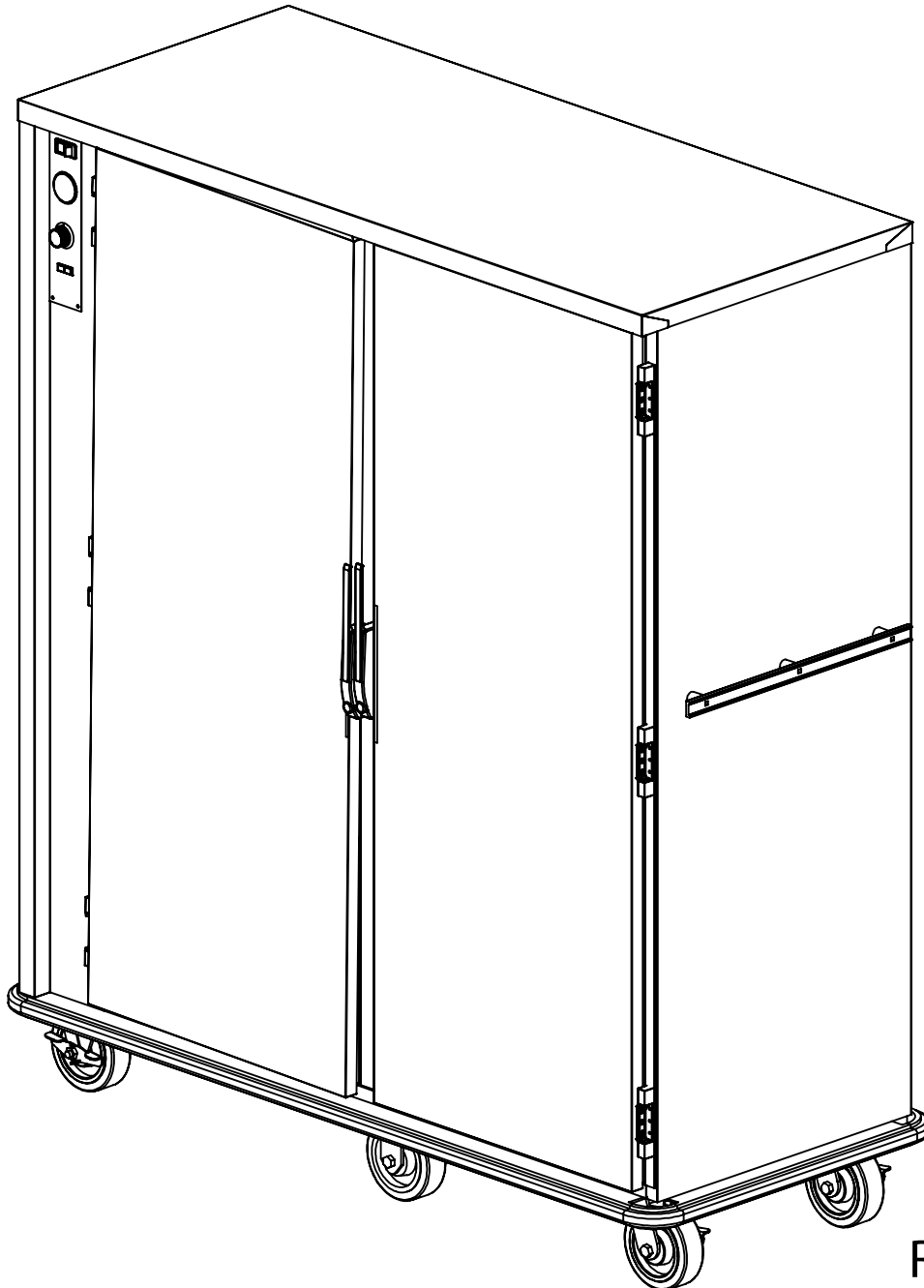

REV: 4/16/10

CONTROL PANEL OPTIONS

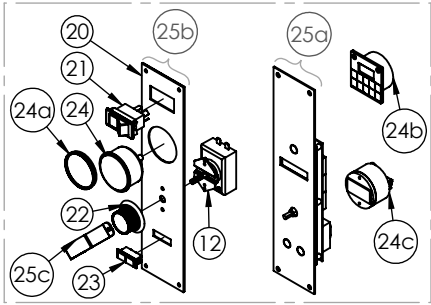

LATCH OPTIONS

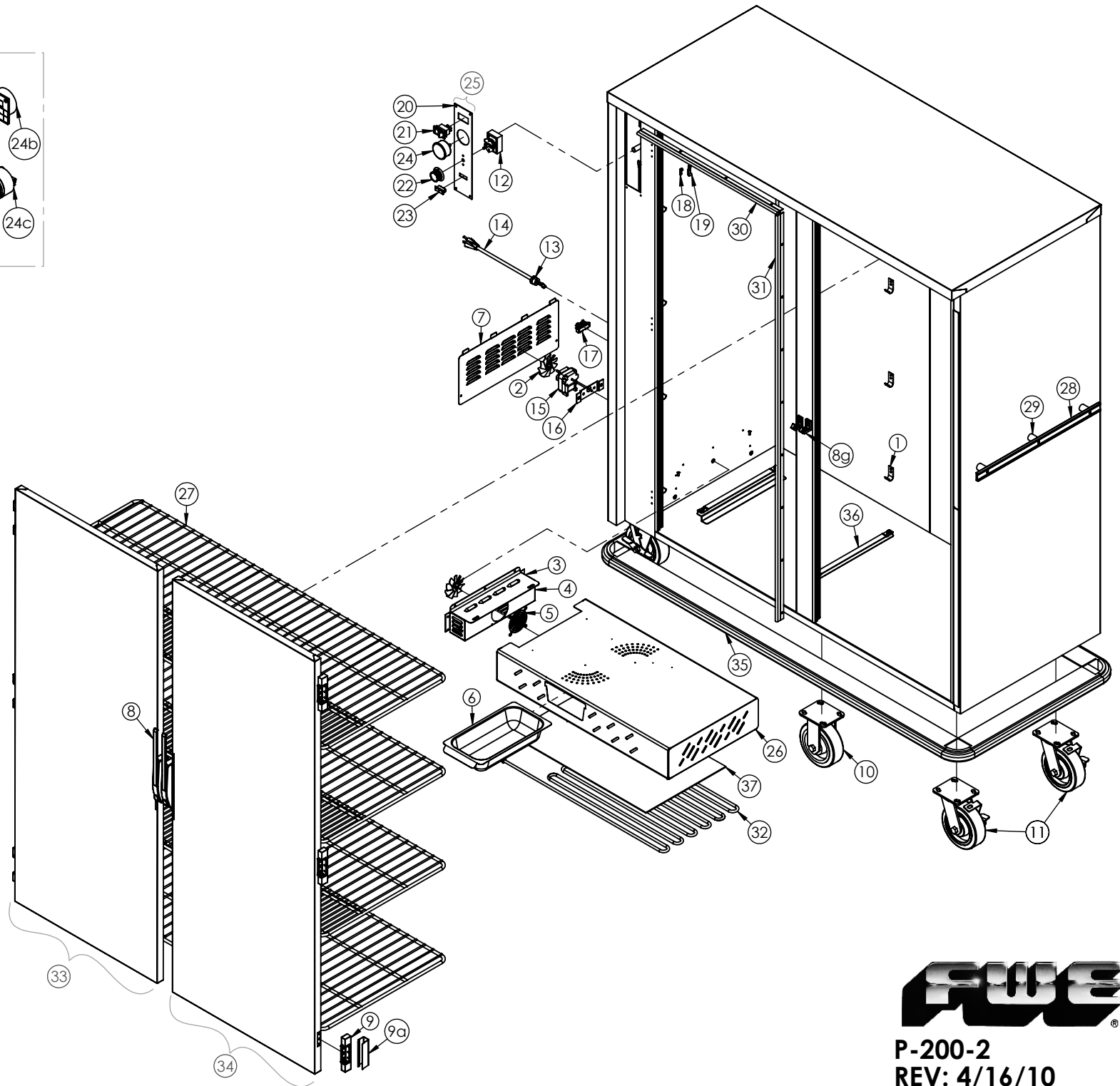
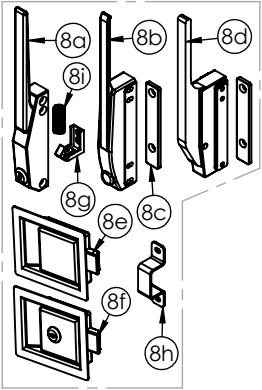

P-200-2
REV: 4/16/10

P-200-2 PARTS LIST				
NOTE: CALL MANUFACTURER IF PART IS NOT LISTED				*ELEMENT AND CORD OPTIONS FOR P-200-2
ITEM NO.	QTY.	PART NO.	DESCRIPTION	EL1600-115HT-XL-28
1	24	CLP SHLF J	SHLF SUPPORT SS J HOOK	CRDSET 10/115
2	2	BLD FAN AL	BLADE FAN AL 3IN 1875-0 (120 V)	EL2000-115HT-XL-28
3	1	4041	HUMITEMP BLOWER LID	CRDSET 20/115
4	1	4011	HUMITEMP BLOWER HOUSING	EL2000-220HT-XL-28
5	1	GRD FAN	GUARD FAN HUMI-TEMP UNITS	CRDSET 10/220
6	1	WATER-PAN-3RD-WHDL	Water-Pan-3rd-WHDL	
7	1	53454	HUMITEMP LOUVER PANEL W/TABS	
8	2	LTH-DR	EDGEMOUNTED DOOR LATCH/CHROME (STANDARD) INCLUDES ITEM 8g	
8a	2	LTH-DR LK	EDGEMOUNTED DOOR LATCH/CHROME WITH LOCK (OPTION) INCLUDES 8g	
8b	2	LTH MAG	MAGNETIC CHROME LATCH (OPTION) INCLUDES 8c	
8c	2	LTH-DR-MAG-RH-STRIKE	LATCH OFFSET COMPOSITE, BLACK STRIKE	
8d	2	LTH DR MAG-RH	MAGNETIC LATCH OFFSET COMPOSITE, BLACK (OPTION) INCLUDES 8c	*OTHER DOOR OPTIONS AVAILABLE -
8e	2	LTH PDL-STD 50	PADDLE LATCH 4.000 X 5.000 1/2IN STD (OPTION)	CALL FACTORY FOR IDENTIFICATION
8f	2	LTH PDL LK-STD 50	PADDLE LARGE SS WL 30250 (OPTION)	
8g	2	STK LTH 1	STRIKE USED FOR EDGEMOUNTED DOOR LATCH	
8h	2	5160	STRIKE USED FOR LOCKING AND NON-LOCKING PADDLE LATCHES	
8i	2	LTH DR SPG	SPRING USED FOR EDGEMOUNT LATCH	
9	6	HNG-214	HINGE CAB DR CRM .875	
9a	6	HNG 214 COVER	HINGE COVER (OPTION)	
10	2	CSTR 6	CASTER HEAVY DUTY STANDARD 6" RIGID	
11	4	CSTR 6 SB-5	CASTER HEAVY DUTY STANDARD 6" SWIVL	
12	1	T-STAT H1	THERMOSTAT CAB 90-190 36IN	
13	1	BSH STRN 3	STRAIN-RELIEF BLK 6N3-4	
14*	1	CRDSET-10/115	CORDSET 10FEET 115V (STANDARD)- REF ELEMENT AND CORD OPTIONS	
15	1	MTR JK120 92	MOTOR, 120V (VERIFY VOLTAGE)	
15a	1	MTR JK 220 93	MOTOR, 220V (VERIFY VOLTAGE)	
16	1	4009	MOTOR MOUNT BRACKET	
17	1	TRM 3QC	TERMINAL BLOCK 3 QC TERM	
18	2	CLP-AL1-4	CLAMP ALUMINUM .250 WIDE	
19	1	CLP-AL3-8	CLAMP ALUMINUM .375 WIDE	
20	1	CNTRL-PNL-HUMI-TEMP-AL	HUMITEMP CONTROL PANEL BLANK X 2	
21	1	SWH RCK E1	ROCKING SWITCH NON-LT 20A,125V	
22	1	KNB H6	KNOB CONTROL ALUMINUM SKIRT SILVER	
23	1	LT-PLT-A-G	LIGHT AMBER/GREEN 125V	
24	1	T-METER H1	THERMOMETER 100/220F (STANDARD)	
24a	1	T-METER-LENS-COVER	THERMOMETER 100/400 LENS (OPTION)	
24b	1	T-MTR-DIG-40F-300F	SOLAR POWER DIGITAL THERMOMETER (OPTION)	
24c	1	T-MTR DIG F	DIGITAL THERMOMETER (OPTION)	
25	1	Z-600-1014	HUMITEMP CONTROL ASSY. INCLUDES ITEMS 20,21,22,23,24 (STANDARD)	
25a	1	CNTRL HUMI-TEMP	DIGITAL HUMI-TEMP CNTRL (OPTION)	
25b	1	Z-600-1460	HUMITEMP CONTROL ASSY. INCLUDES ITEMS 20,21,22,23,24,25c (OPTION)	
25c	1	5561	THERMOSTAT RETENTION STRAP HDM	
26	1	50001	P-200-2 WATER PAN TUNNEL	
27	3	SHLF-P200	SHELF 22.25 X 54.75 P-180	
28	2	HDL 21.5 AL	HANDLE PUSH AL 21.5	
29	6	SPCR 125X.330	SPACER PUSH HDL 1.25X5/16	
30	1	Z-700-1056	GASKET AND HOLDER ASSY. 22.75 INCH	
31	2	Z-700-1079	GASKET AND HOLDER ASSY. 66 INCH	
32*	1	EL2000-220HT-XL-28	HEAT ELEMENT 2000W 220V HUMI (STANDARD) (VERIFY VOLTAGE)	
33	1	Z-301-2387	P-200-2 DOOR ASSY. INCLUDES ITEM NO. 8, 9	
34	1	Z-301-1799	P-200-2 DOOR ASSY. INCLUDES ITEM NO. 8, 9	
35	1	Z-200-1049	BUMPER ASSY. P-200-2	
36	2	5958	P-120 1600W ELEMENT BRACKET STRAP	
37	1	50300	P-120 ALUMINUM HEATING ELEMENT COVER	