

SERVICE MANUAL

STG7 P GAS FIRED ROTISSERIE OVEN

MODELS

Programmable controls STG7 P

Gas types **G20/25**



Model STG7 P Gas

- NOTICE -

This manual is prepared for the use of trained Service Technicians and should not be used by those not properly qualified. If you have attended training for this product, you may be qualified to perform all the procedures in this manual.

This manual is not intended to be all encompassing. If you have not attended training for this product, you should read, in its entirety, the repair procedure you wish to perform to determine if you have the necessary tools, instruments and skills required to perform the procedure. Procedures for which you do not have the necessary tools, instruments and skills should be performed by a trained technician.

Reproduction or other use of this Manual, without the express written consent of Fri-Jado, is prohibited.



USA

EMPTY PAGE

Versions		
Version	Issue date dd/mm/yy	Remarks
02/2009	01/03/2012	First release.
07/2012	01/07/2012	Various adjustments.
02/2013	01/02/2013	Adjusting of power changed. Blower added in electric compartment.
04/2013	01/04/2013	Adjusting power changed on pages 23 to 29. Trouble shooting adjusted.
05/2013	01/05/2013	Adjusting power changed on pages 23 to 29.

INDEX

Index	4
General technical data	6
Programming instructions	7
Removal and replacement of parts for the STG7 P Gas	11
Right or left side panel	11
Top cover	11
Knob	11
Instrument panel	12
Tumble switch reset	12
Electric panel.....	12
Display	13
Panel and keypad assembly	13
Namepanel	13
Halogen lamp holder (customer side)	14
Halogen lamp holder (service side)	14
Power section.....	15
Safety thermostat	15
Main switch	16
Blower motor	16
PT500 sensor.....	17
Drive motor.....	17
Gas mixture blower	18
Gas burner safety control.....	18
Gas control block	19
Ignition/Ionization set	19
Board speed control blower.....	19
Relay and base relay	20
Rectifier	20
Ring core transformers.....	20
Door adjustment (left side)	21
Door glass inside	21
Door glass outside	21
Changing an orifice and air inlet.....	22

Working of gas fired rotisserie	23
Gas technical data.....	24
Electrical tests and service procedures.....	25
PT500 sensor test	25
Keypad test	25
Adjustment of board for speed/power regulation.....	26
Temporary bridging of reset switch	27
Gas block Honeywell type VK4115V.....	28
Adjusting of the power for Natural gas and Propane	29
Ignition/Ionization set	30
Control location	31
Troubleshooting for the STG7 P Gas Rotisseries.....	32
Exploded views & partlists.....	34
STG7 P Gas - sheet iron work	34
STG7 P Gas - components.....	36
Electrical diagrams	39
STG7 P Gas - circuit diagram	39
STG7 P Gas - wiring diagram.....	40
STG7 P Gas - wiring diagram (till serial number 100054530).....	41

GENERAL TECHNICAL DATA

This manual covers the STG 7 P gas fired rotisserie ovens suitable for G 20/25 (natural gas).

- STG 7 – Oven with seven spits (28 to 35 chickens).

All of the information, illustrations and specifications contained in this manual are based on the latest product information available at the time of printing.

Note: From Dec. 2008 on the gas pipe ends under the STG 7 instead of at the rear end. A knee piece and an 8 inch nipple (NPT to BSP thread) are delivered with the unit.

TECHNICAL DATA

Type	STG 7	
Power (W)	345	
Gas power (BTU - KW)	49.500 - 14.5	
Fuses needed with power connection 115 V, 1N ~50...60 Hz (1 phase with zero)	1x 15 A	
Standard plug from factory	NEMA 5-15	
Net weight	204 kg	450 lbs
Gross weight	230 kg	507 lbs
Height	1025 mm	40 1/4 inch
Width	985 mm	38 3/4 inch
Depth	850 mm	33 1/2 inch

Tools

- Standard set of tools.
- Metric wrenches, sockets and hex socket key wrenches.
- Multi-meter and AC current clamp tester.
- Temperature tester.
- Insulation value tester (Megger).
- Toxicity meter.
- Gas pressure meter.
- Field Service Grounding Kit.

PROGRAMMING INSTRUCTIONS

DISPLAY AND KEYS

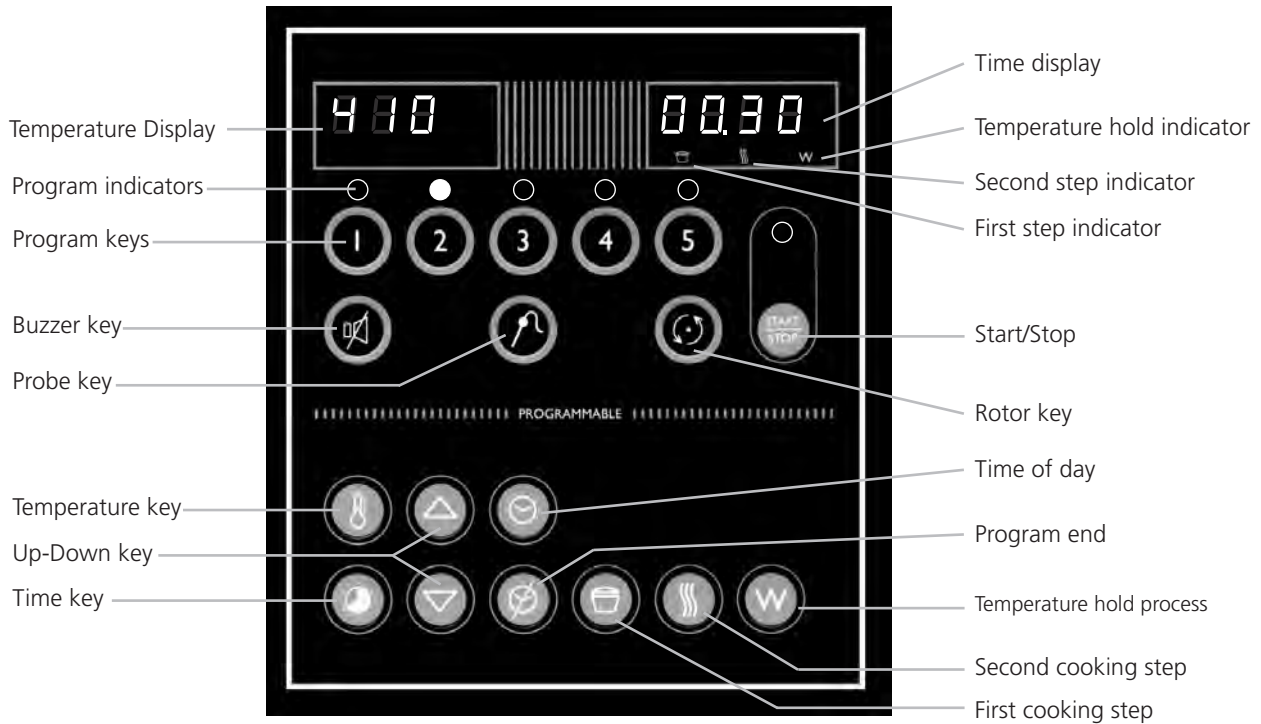

SETTING THE STG



When the main switch is tuned to "1" the display lights up and the rotisserie is ON.

SETTING ACTUAL TIME

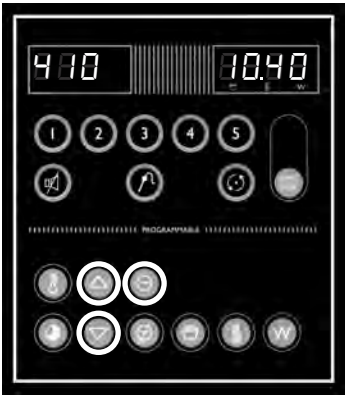

Press and hold *Time of day* key

Press *Up* or *Down* key

Release *Time of day* key

15 PROGRAMS

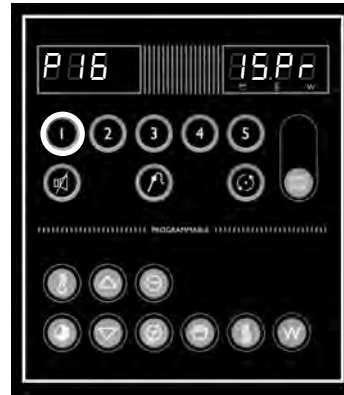

After the unit is switched-on the time display indicates: 15PR

Key 1:

1x = program 01

2x = program 06

3x = program 11

Key 2:

1x = program 02

2x = program 07

3x = program 12

ENTERING A PROGRAM

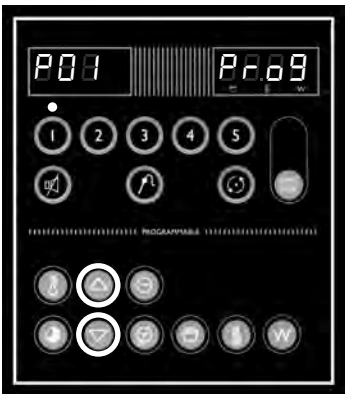

Select Program number

Press both *Up* and *Down* keys during 2 seconds

FIRST COOKING STEP (TIME)



Press *Cooking process* key

Cooking symbol lights up

Press and hold the *Time* key

Press *Up* or *Down* key

FIRST COOKING STEP (TEMP.)

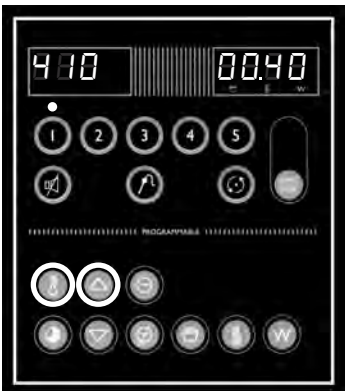

Press and hold the *Temperature* key

Press *Up* or *Down* key

SECOND COOKING STEP (TIME)

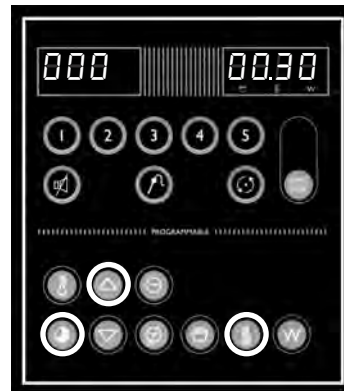

Press *Grilling process* key

Grilling symbol lights up

Press and hold the *Time* key

Press *Up* or *Down* key

SECOND COOKING STEP (TEMP.)

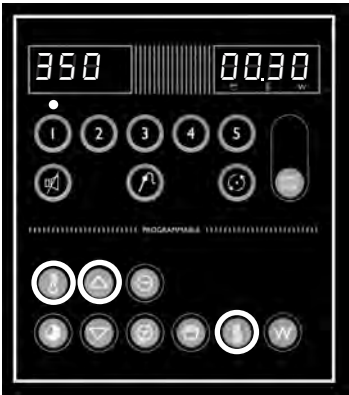

Press and hold *Temperature* key

Press *Up* or *Down* key

TEMPERATURE HOLD

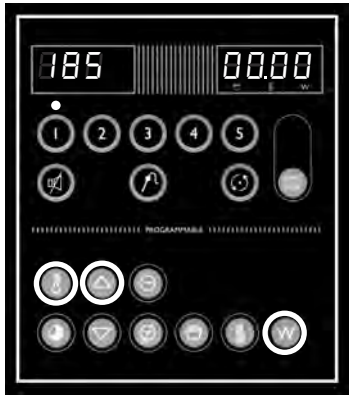

Press *Temperature Hold process* key

Temperature Hold symbol lights up

Press and hold the *Temperature* key

Press *Up* or *Down* key

LOADING PROGRAM

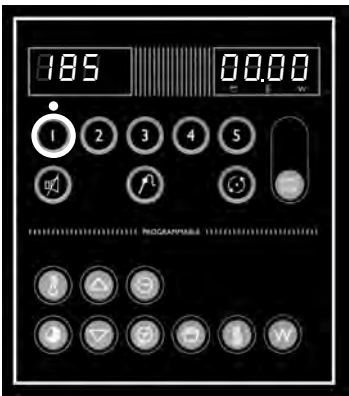

Press program number to load pre-set values

PROGRAM START & LOADING

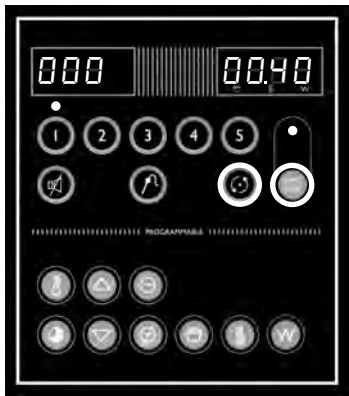

Press *Start / Stop* key

On indicator lights up

Press *Rotor* key to start turning the rotor

Press *Rotor* key again to stop

Load the rotisserie with products

OPTIONAL SETTINGS

INTERRUPTING ACTIVE PROGRAM

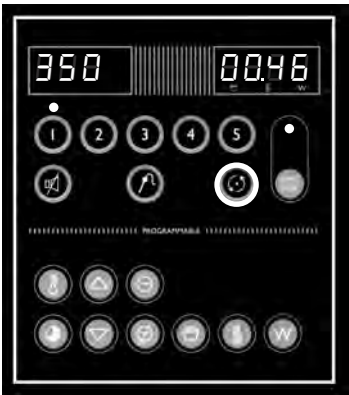

Press *Rotor* key

Heaters and front lamp switch off

Rotor stops

On indicator is blinking

Process time in hold

SET ADDITIONAL BUZZER SIGNAL

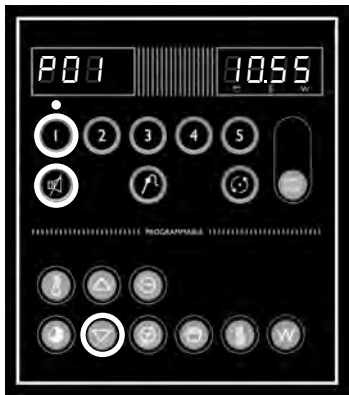

Select a pre-defined program

Press and hold *Buzzer* key

Press *Down* key

SET PROGRAM END TIME

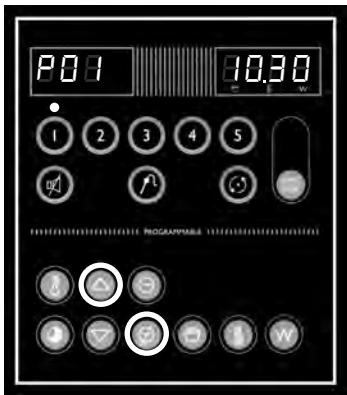

Select a pre-defined program

Press and hold the *Program end* key

Press *Up* key

DISPLAY SET TIME & TEMPERATURE

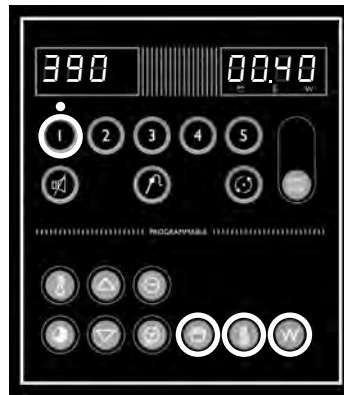

Select a pre-defined program

Press *Cooking, Grilling* or *Temperature hold* key

No time indication for *Temperature hold*

Visible during process or program selection

ADJUSTING ACTIVE PROGRAM

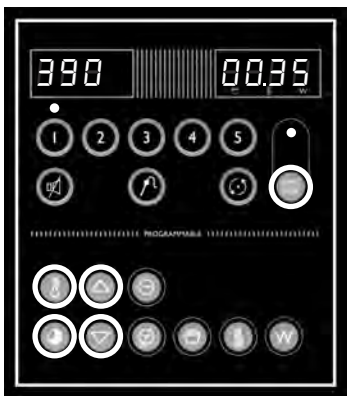

Press and hold *Temperature* or *Time* key

Adjust temperature or time with *Up* or *Down* key

PREHEAT INDICATION



Under 40°C (104°F) the display shows *PRH*

TEMPERATURE PROBE (OPTIONAL)

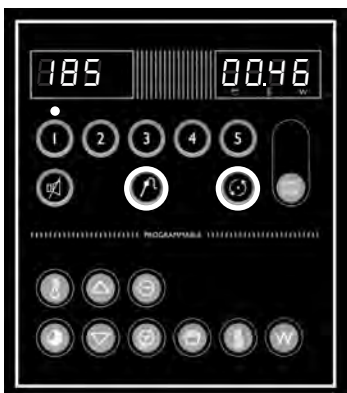

Press the *Rotor* key

Insert the probe in the meat up to the core

Press *Temperature sensor* key; after 20 seconds the temperature reading switches off

INDICATIONS DURING PROCESS

- *Process indicators* shows actual process. After completion indicator switches off
- *Time display* shows remaining program time which is the sum of the remaining cooking and grilling time
- *Temperature display* indicates actual temperature in the grill. Under 40°C(104°F) the display shows *PRH* (preheat)When remaining time reaches 0, the process indicators and the *On-indicators* switches off

REMOVAL AND REPLACEMENT OF PARTS FOR THE STG7 P GAS

WARNING: Disconnect the electrical power to the machine at the main circuit box. Place a tag on the circuit box indicating the circuit is being serviced.

RIGHT OR LEFT SIDE PANEL



1. Remove the screws that secure the panel to the frame.
2. Remove the panel.
3. Reverse the procedure to install.

TOP COVER

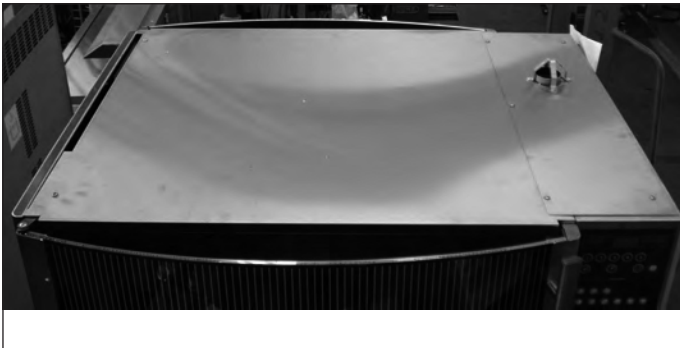

1. Remove the left side panel according prior procedure.
2. Remove the screws securing both large and small top covers.
3. Remove the small cover.
4. Remove the large top cover. (Lift at left side and remove to the left).
5. Reverse the procedure to install.

KNOB



1. Remove cover plate on the knob with a small screw driver.
2. Loosen the screw inside the knob.
3. Remove the knob with ring.
4. Reverse the procedure to install.

Note: check that the ring behind the knob is in the right position and runs free from the panel.

INSTRUMENT PANEL

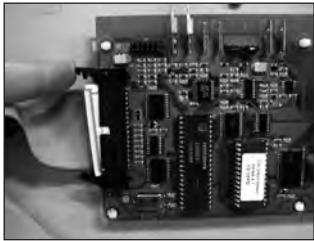

1. Remove the right side panel according prior procedure.
2. Remove the knobs according prior procedure.
3. Remove the screw that secures the panel.
4. Remove the 2 bolts on the backside of the instrument panel.
5. Remove the screws that secure the meat probe holder and remove the holder (if supplied).
6. Remove the flatcable on the power section.
7. Remove the clip on the back, top left side that secures panel and frame.
8. Remove the instrument panel.
9. Reverse the procedure to install.

TUMBLE SWITCH RESET



1. Remove the right side panel according prior procedure.
2. Remove the wiring.
3. Remove the switch by pushing the clamps with a screw driver.
4. Reverse the procedure to install.

ELECTRIC PANEL



1. Remove the instrument panel according prior procedure.
2. Remove on the front side the screws that secure the panel.
3. Remove on the inside bottom of the electric panel the bolt and nuts.
4. Disconnect the wiring.
5. Slide the electrical panel backwards.
6. Reverse the procedure to install.

DISPLAY

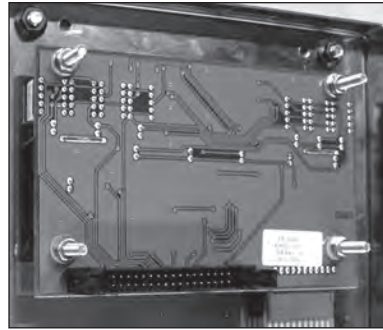

1. Remove the right side panel according prior procedure.
2. Disconnect the flatcable on the display.
3. Remove the clip on the back, top left side that secures panel and frame.
4. Remove the nuts and washers on the back-side of the display and remove the metal cover.
5. Remove the nuts and plastic rings that secure the board and remove the board. Do not forget to disconnect the blue connector on the board.
6. Reverse the procedure to install.

PANEL AND KEYPAD ASSEMBLY

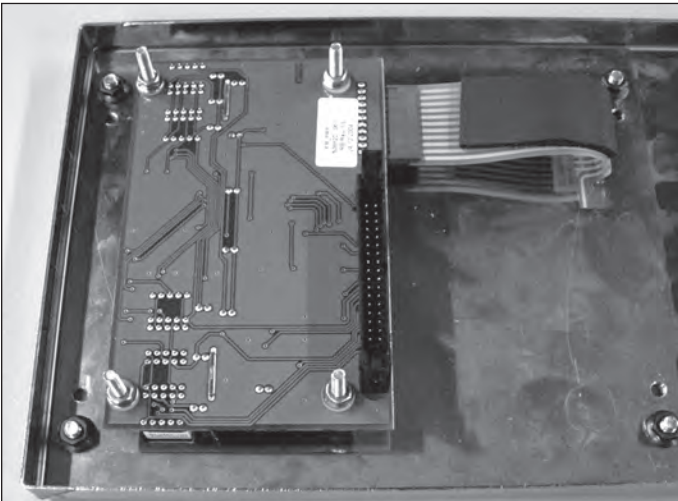

1. Remove the instrument panel according prior procedure.
2. Remove the display according prior procedure.
3. Remove the nuts that secure the panel with foil and remove panel.
4. Reverse the procedure to install.

NAMEPANEL



1. Remove the instrument panel according prior procedure.
2. Remove the 4 nuts that secure the panel and remove panel.
3. Reverse the procedure to install.

HALOGEN LAMP HOLDER (CUSTOMER SIDE)

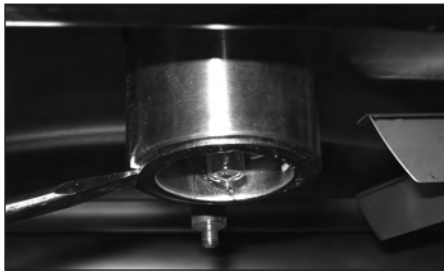
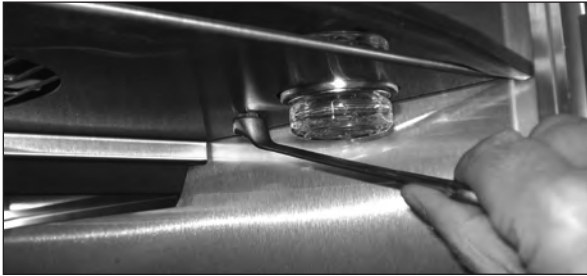

1. Remove the top cover according prior procedure.
2. Remove the wiring of the lamp on the connector.
3. Remove the cap nuts that secure the air suction plate and remove this plate.
4. Remove the glass and lamp from the lamp holder. Turning direction of glass in counter clockwise.
5. Remove the holder. You have to deform the holder to take it out.
6. Insert a new holder and click this in.
7. Reverse the procedure to install.

HALOGEN LAMP HOLDER (SERVICE SIDE)

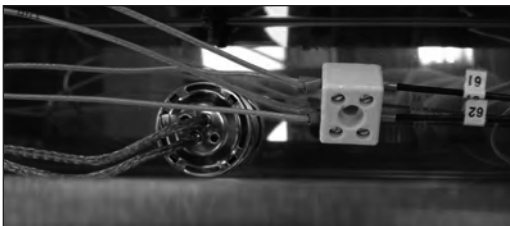

1. Remove the top cover according prior procedure.
2. Remove the wiring of the lamp on the connector.
3. Remove the glass and lamp from the lamp holder. Turning direction of glass in counter clockwise.
4. Remove the holder. You have to deform the holder to take it out.
5. Insert a new holder and click this in.
6. Reverse the procedure to install.

POWER SECTION

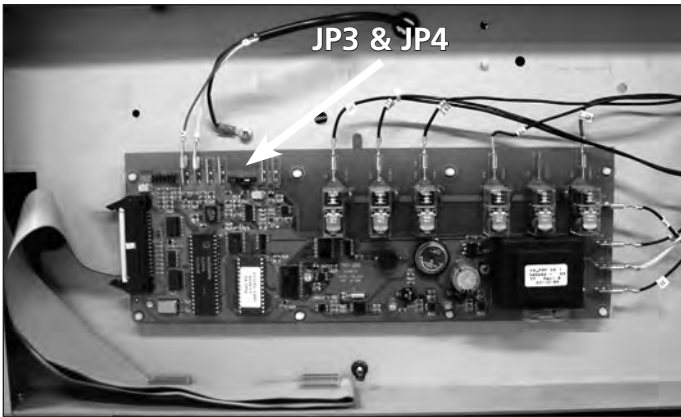

1. Remove the right side panel according prior procedure.
2. Disconnect wiring and flatcable on the board.
3. Remove the board from the clips by pressing the clips together.
4. Reverse the procedure to install.

Note: When installing new board, ensure that JP3 and JP4 on new board are set the same as on the old board.

SAFETY THERMOSTAT



1. Remove the rotor and the right side panel according prior procedure.
2. Remove the bolts that secure the air guide plate and remove this plate. Lower the plate in vertical position and lift it out of the hinge pins.
3. Remove the thermostat-probe from the clip in the oven and guide it outside through the opening in the side wall.
4. Disconnect the wiring on the thermostat.
5. Remove the screws on the electric panel that secure the thermostat and remove the thermostat.
6. Reverse the procedure to install.

Note: Set the new thermostat to its maximum position by turning it clockwise (320°C/608°F).

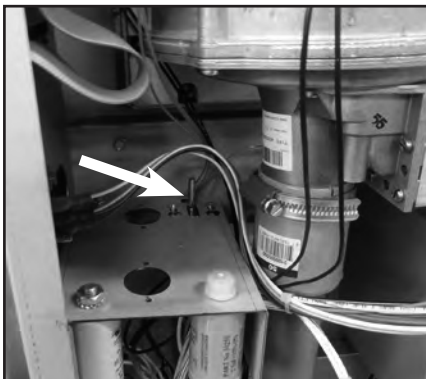

MAIN SWITCH



1. Remove the instrument panel according prior procedure.
2. Loosen the screws on the electric panel that secure the switch.
3. Remove the switch and disconnect the wiring.
4. Reverse the procedure to install.

Note: The old version main switch is used until serial number 100052400.



Old version
main switch

BLOWER MOTOR

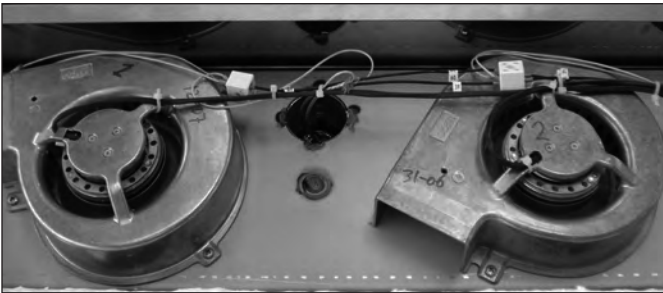

1. Remove the right side panel, the top cover and the air suction plate according prior procedures.
2. Remove the wing nut on the fan blade and remove fan blade. (Left handed threads).
3. Disconnect wiring of the motor.
4. Remove the screws that secure the motor and remove the motor.
5. Reverse the procedure to install.



Note: The blowers are equipped with a capacitor. Check the direction of rotation of the motor (clockwise) and change the wiring if necessary.

PT500 SENSOR



1. Remove the right side panel according prior procedure.
2. Disconnect the wiring of the sensor.
3. Remove the screw that secures the sensor and remove the sensor.
4. Reverse the procedure to install.

Note: The wiring cable is an insulated cable with an earthing screen.

DRIVE MOTOR

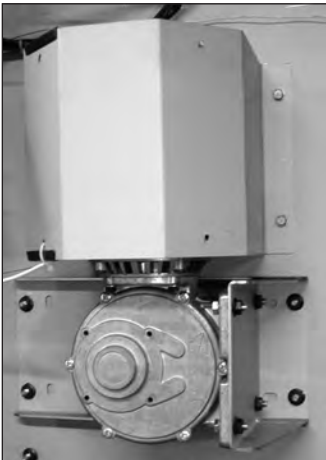

1. Remove the right side panel and rotor discs according prior procedure.
2. Disconnect the wiring of the motor. Check where the wire, marked A is connected.
3. Remove the screws that secure the fan cover and remove the cover.
4. Set the drive arm in a position vertical downwards. This can be done manually or by turning the fan blade by hand.
5. Mark the position of the motor support with a marker.
6. Remove the bolts that secure the motor and the nuts that secure the motor support and remove the motor.
7. Check the white Teflon ring. Replace if necessary.
8. Install the fan blade on the new motor.
9. Reverse the procedure to install.

Note: Always make a test run on maximum temperature to insure the motor is well mounted and adjusted.

GAS MIXTURE BLOWER

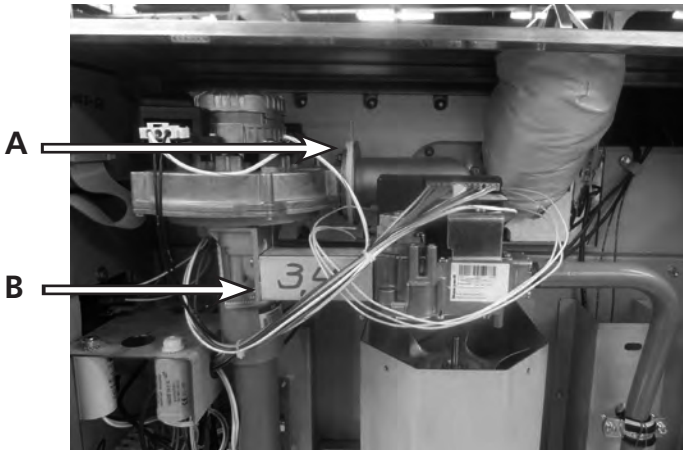

1. Remove the right side panel and small top cover plate according prior procedures.
2. Remove the wiring from the top of the gas mixture blower
3. Remove the silencer.
4. Remove the 4 nuts from the air inlet (A) and the 4 long screws from the gas mixture blower (B) and remove the gas mixture blower.
5. Remove the screws that secure the venture to the blower and remove the blower.
6. Reverse the procedure to install.

Note: When replacing the air inlet see to it that the text is visible from the right hand side.

GAS BURNER SAFETY CONTROL



1. Remove the right side panel according prior procedure.
2. Remove the wiring from the control.
3. Remove the screw that secures the control and remove the control by lifting it upwards.
4. Reverse the procedure to install.

GAS CONTROL BLOCK

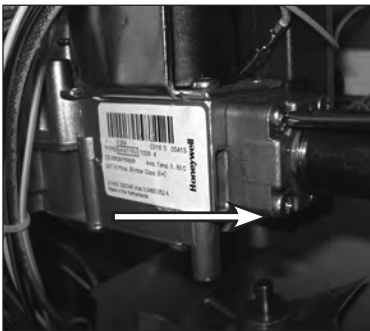
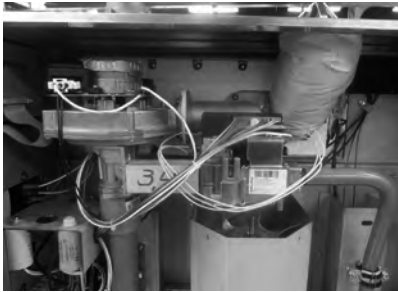

1. Remove the right side panel and the gas burner safety control according prior procedures.
2. Remove the 4 long screws from the gas mixture blower.
3. Remove the wiring.
4. Remove the screws from the pipe clamps.
5. Remove the screws that secure the flange to the block and remove the control block.
6. Reverse the procedure to install.

IGNITION/IONIZATION SET

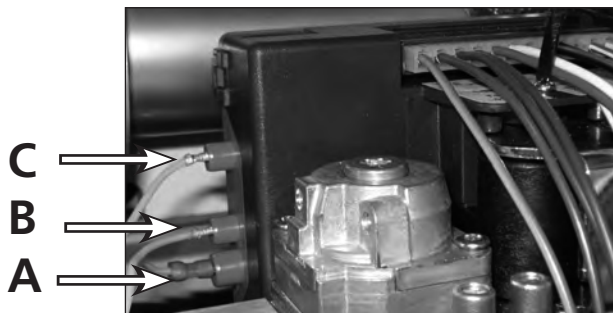
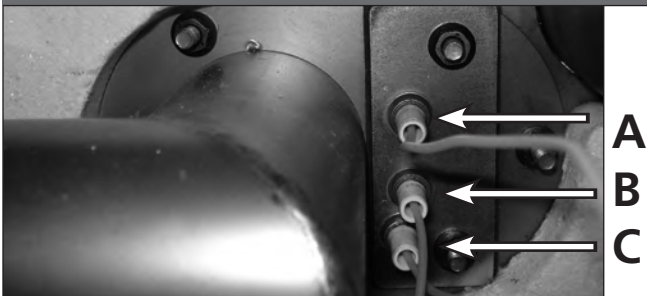

1. Remove the right side panel according prior procedure.
2. Remove the wiring from the set on the gas burner safety control.
3. Remove the nuts that secure the set and remove the set. Check the gasket and replace if necessary.
4. Reverse the procedure to install.
5. Connect A to A , B to B and C to C. , the fastons for B and C are the same, (2.8 mm - .110") the faston for A is bigger (4.8 mm - .188")

BOARD SPEED CONTROL BLOWER

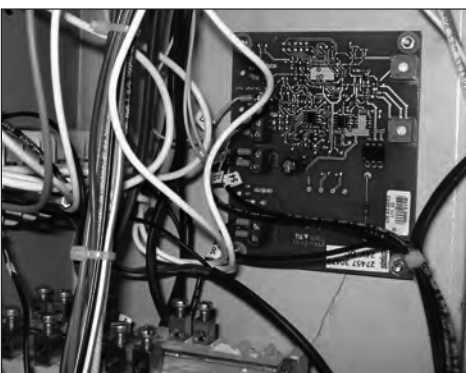

1. Remove the right side panel according prior procedure.
2. Remove the screws that secure the board and remove the board.
3. Reverse the procedure to install.

Note: See page 25 for adjustment of speed regulation.

RELAY AND BASE RELAY

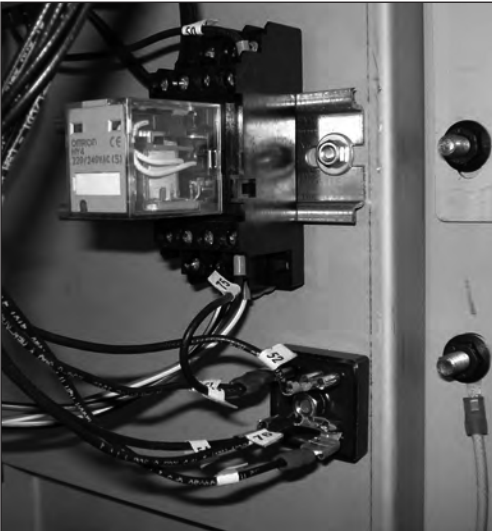

1. Remove the right side panel according prior procedure.
2. Remove wiring of relay.
3. Slide base from rail.
4. Reverse the procedure to install.

RECTIFIER



1. Remove the right side panel according prior procedure.
2. Remove the wiring of the rectifier.
3. Remove the nut that secures the rectifier and remove the rectifier.
4. Reverse the procedure to install.

RING CORE TRANSFORMERS

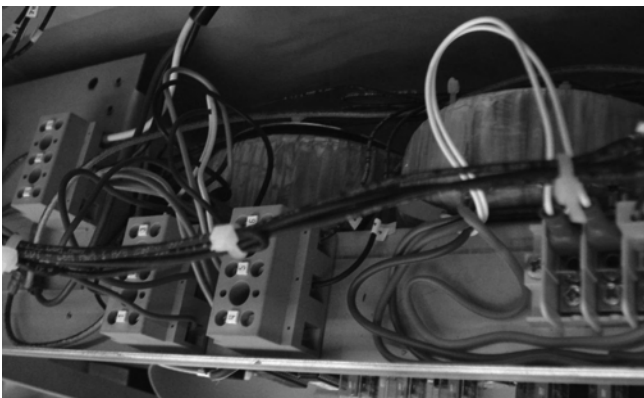

1. Remove the right side panel according prior procedure.
2. Remove the wiring from the transformer.
3. Remove the screw and nut that secure the transformer and remove the transformer.
4. Reverse the procedure to install.

DOOR ADJUSTMENT (LEFT SIDE)



1. Remove the left side panel according prior procedure.
2. Loosen the nuts of the upper hinge. The door must be closed.
3. Loosen the locknut and adjust the bolt in or out to adjust the door.
4. Tighten the nuts of the hinge and mount the left-hand panel.

DOOR GLASS INSIDE



1. Lift the door upward out of the hinges and place on a table.
2. Remove the cap nuts and rings on the profiles of the door.
3. Remove the profiles from the glass.
4. Mount the profiles on the new glass. Do not forget the nylon rings inside the holes and the rings between metal and glass.
5. Mount the cap nuts and rings. Note! Tightening of nuts max. 4.2 Nm. or 3.1 Lbf.ft
6. Place the door in the hinges.

DOOR GLASS OUTSIDE



1. Lift the inner door out of the hinges and lay aside.
2. Remove the left side panel according prior procedure.
3. Remove the 2 nuts behind the top hinge. The door must be closed.
4. Hold the door on both sides and move this towards yourself, before lifting it out of the hinges. Place the door with the rounded side down on a table.
5. Remove the screws, cap nuts and rings on the profiles of the door and remove the profiles.
6. Mount the profiles on the new glass. Do not forget the nylon rings inside the holes and the rings between metal and glass.
7. Reverse the procedure to install.

CHANGING AN ORIFICE AND AIR INLET

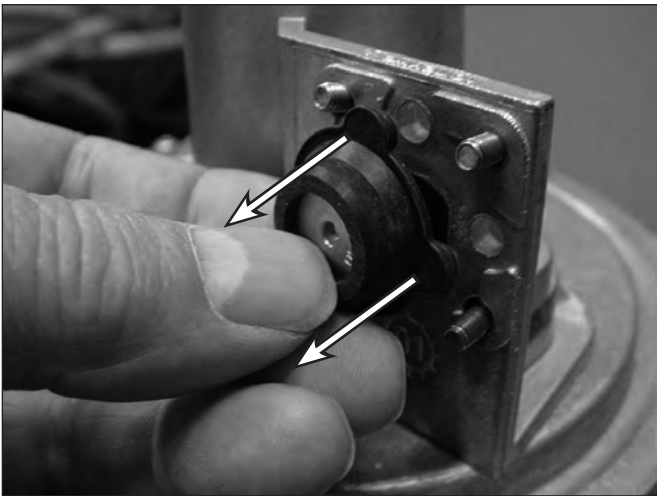
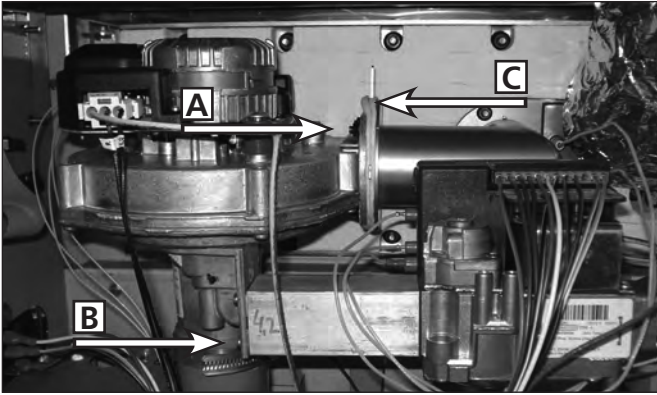

1. Remove the wiring from the top of the gas mixture blower. Remove the silencer.
2. Remove the four nuts from the air inlet (A) and the 4 long screws from the gas mixture blower (B). Remove the gas mixture blower.
3. Remove the gasket and air inlet from the coupling tube and replace the air inlet (text visible from right hand side (C)).
4. Take the rubber holder with the orifice plate out of the metal where it is positioned by 2 rubber notches, which fit in the holes of the plate.
5. Carefully replace the orifice disc by a disc with the desired opening. Put the rubber holder against the plate. See to it that the notches fit in the opening. Bring the parts in position and mount the 4 long screws and nuts.
6. Replace the silencer and connect the wiring.
7. Check for tied fitting with help of soapy water or spray.

G20/25: orifice is 4.2 mm (1/6"). Air inlet is 18.1 mm (3/4").

G 31: orifice is 3.4 mm (1/7"). Air inlet is 16.5 mm (2/3").

WORKING OF GAS FIRED ROTISSERIE

After plugging the unit in always first check the proper polarity for good ignition.

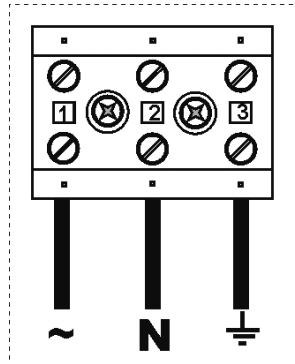

After switching the main switch on, the gas mixture blower starts to run in high speed. This is to ensure that there is no gas left in the heat exchanger and that the heat exchanger is clean. Also after ending of a grilling process the blower will keep on turning.

After selection of a program and pressing the start/stop key the transformer is activated by relay X18 on the power board. The transformer reduces the voltage to 12V AC for the lighting and 24V AC for the rectifier. Via the rectifier we have a 31V DC voltage on the speed regulation board, which takes over the low speed (16V DC) of the blower. At the same time relay X12 activates the contact 9/10 on the burner control. The burner control now activates the following functions: Gas valve is activated, the spark plug is activated and will ignite a number of times and the ionization is activated. (The blower still runs on low speed to create a rich gas/air mixture for easy and fast ignition).

After ignition/burning of the gas/air mixture and measuring of the correct ionization voltage in the burner control, relay K3 will be activated by the burner control and contact K3/1 comes in and on the speed regulation board this 24V AC signal activates the high speed of the blower (22-24V DC for Natural gas and 20-22V DC for Propane).

The PT 500 sensor now takes care of the temperature regulation of the oven, by switching the burner control on and off.

If there is no ignition/burning of the gas within 15 seconds the burner control will close the gas valve and activates the red indication lamp on the reset switch. By pressing this switch once the process will start again.

Note: See also separate instructions of the speed regulation board. Gas supply pressure should be between 13 and 50 mbar (5 and 20 inch wc), depending on the gas type. See table on next page.

Pressure over 60 mbar (24 inch wc) will damage the gas block. You can check the pressure on the gas block. Valves on the gas block can be checked by holding your hand on it, or by holding a steel object on the coil. This will be magnetic after switching in.

GAS TECHNICAL DATA

Gas type	Inlet pressure inch wc	Inlet pressure mbar-PSI	min pressure (Qn-Hi) inch wc	min pressure (Qn-Hi) mbar	Consumption cfm - LBS - kg	Consumption m3/h	Power BTU
G20	8	20 - 0.3	6	14.5	0.89 - 2.2 - 1	1.51 m3/h	49.500
G25	10	25 - 0.36	6	14.5	1.01 - 2.5 - 1.13	1.71 m3/h	49.500
G31	20	50 - 0.73	6	14.5	0.32 - 0.8 - 0.36	0.55 m3/h	49.500

ELECTRICAL TESTS AND SERVICE PROCEDURES

WARNING: Disconnect the electrical power to the machine at the main circuit box. Place a tag on the circuit box indicating the circuit is being serviced.

PT500 SENSOR TEST

Temperature		Resistance
°F	°C	± 5 Ohms
60	16	531
70	21	541
80	27	553
90	32	562
100	38	574
125	52	601
150	65	626
200	94	681
250	121	732
350	177	837
450	233	940

1. Remove the right side panel according prior procedure.
2. Remove the wiring from the sensor.
3. Connect a temperature sensor to the probe for comparison.
4. Test the probe with an Ohmmeter.

KEYPAD TEST

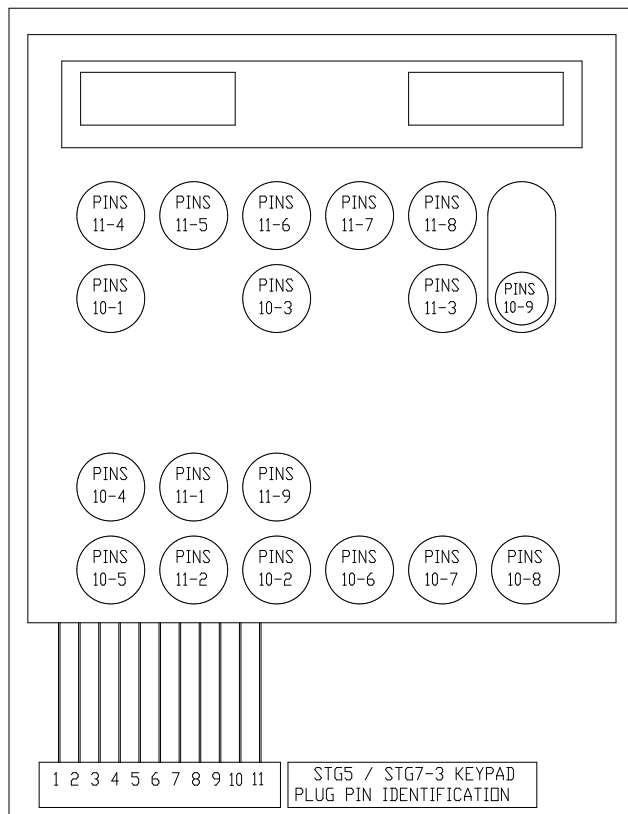

1. Remove the instrument panel according prior procedure.
2. Remove the display according prior procedure.
3. Remove the nuts that secure the panel with foil and remove panel.
4. Use a multimeter to test. Connect the measuring pins to the cable plug pins for each key to be tested as indicated in the diagram. You can set the multimeter on a beep signal or set it on resistance measuring. Press the key to be tested and the meter should give a beep signal or indicates a resistance less than 200 Ohms.

ADJUSTMENT OF BOARD FOR SPEED/POWER REGULATION

The rotisserie starts up with low speed turning of the gas mixture blower. This low speed is adjusted with the potentiometer on the top side of the board. This tension should be around 16V DC and has to be measured on the top connections.

For this adjustment you only have about 2-3 seconds. If the time is too short then start the unit up again.

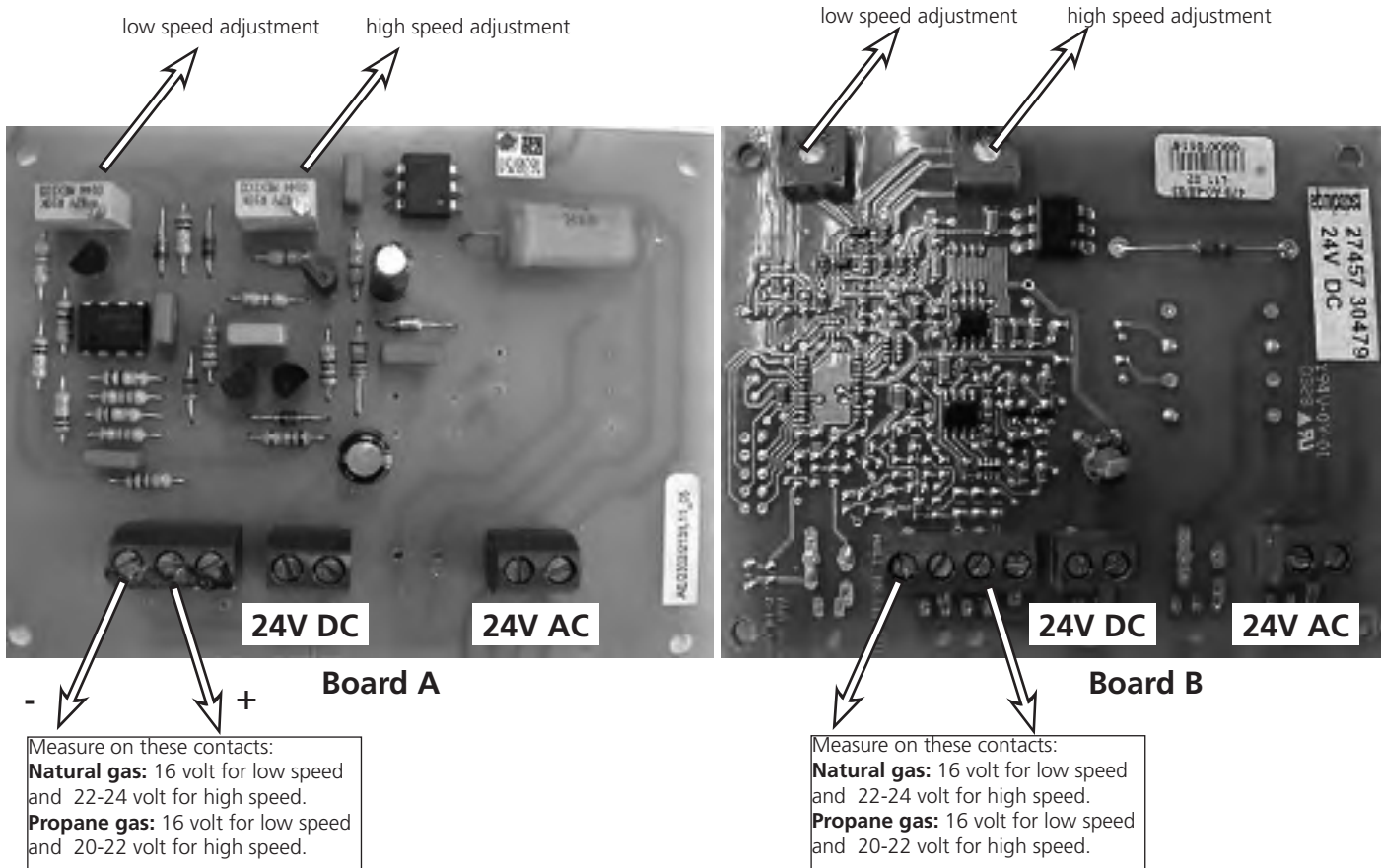

After ignition, when the gas is burning, the gas mixture blower switches to high speed and maximum power.

With the potentiometer on the bottom side you can adjust the power/gas consumption and with that also the high speed. This tension should be 22-24V DC for Natural gas and 20-22V DC for Propane gas and has to be measured also on the top connections.

Note: The tension for the highest speed is the same as the supply voltage of 31V! After this it has no use turning the potentiometer up.

Instructions for measuring low and high speed.

1. Select a program and press the start key.
2. Now you can measure the low speed voltage of 16 Volts for the blower.
3. Once the burner is on the Honeywell burner control generates the signal for the blower to switch to high speed. Now you can measure the Voltage for the high speed.

TEMPORARY BRIDGING OF RESET SWITCH

For testing of the system, when reset switch could be malfunctioning, it is possible to bridge the reset switch by temporary connecting both the white and orange/white - red/black wires together. In this way you can perform a test and do a check up on the reset switch.

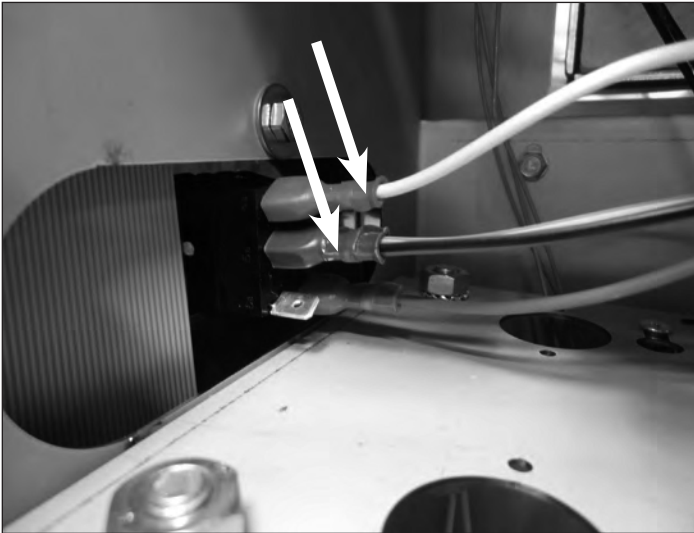

1. Remove these 2 wires from the reset switch.

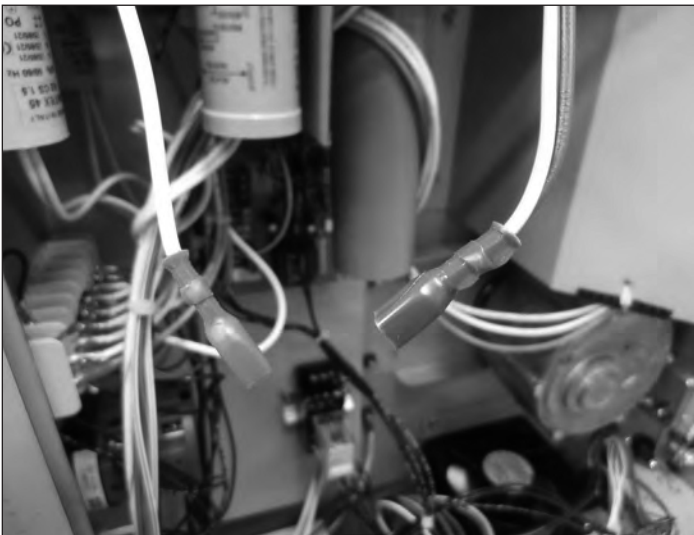

2. Connect these jacks together with a separate wire.
3. Start a program.

GAS BLOCK HONEYWELL TYPE VK4115V

Gas inlet: Inlet of gas after gas pressure control valve (max. 20 inchwc).

Gas outlet: Outlet of gas into gas mixture blower.

Coils: 2 Coils for the gas valves.

Inlet pressure: Measuring tube for gas going into the gas block. In order to measure loosen screw on inside of tube.

Outlet or burner pressure: Measuring tube of gas going into gas mixture blower. In this case it has no use in measuring here (is zero). In order to measure loosen screw on inside of tube. You can use this measuring point also to check if the gas valves are opening.



Gas consumption.

G 20 (natural gas) 0.89 cfm (1.51 m3/h)

G 25 (natural gas) 1.01 cfm (1.71 m3/h)

Orifice for G 20/25 is 3/16" (4.2 mm.)

Air inlet for G 20/25 is 11/16" (18.1 mm.)

ADJUSTING OF THE POWER FOR NATURAL GAS AND PROPANE

Warning: Adjusting of the power is only allowed by a skilled installer and in exceptional cases when toxic measuring devices and flow meters are available. For more information see installation manual.

When a total re-adjustment of the power is necessary then turn the setting screw all the way in, to its end position, by turning it in clockwise direction. Then turn the setting screw open:

Natural gas: for 4 full turns (360°) turning in counter clockwise direction. Now start the rotisserie and measure the high speed adjustment on the speed control board, see page 26. After the temperature has reached about 150°C measure the toxicity of the exhaust air on top. For values see the installation manual.

Propane gas: for 3.5 full turns (360°) turning in counter clockwise direction. Now start the rotisserie and measure the high speed adjustment on the speed control board, see page 26. After the temperature has reached about 150°C (300°F) measure the toxicity of the exhaust air on top. For values see the installation manual.

LP gas: for 2.5 full turns (360°) turning in counter clockwise direction. For continuation see Propane gas.

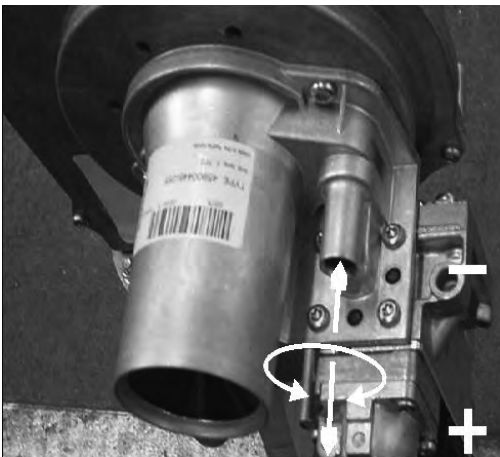

Note 1: You can decrease or increase or the CO₂ value by turning the setting screw in steps of a quarter turn.

Clockwise to decrease the CO₂ value.

Counter clockwise to increase the CO₂ value.

Total deviation cannot be more than half a turn!

Note 2: You can decrease or increase the gas consumption/flow by turning the high speed potentiometer in steps of 1V.

Clockwise to increase gas consumption/flow.

Counter clockwise to decrease the gas consumption/flow.

Total deviation cannot be more than 2 Volts!

Note 3: You can decrease or increase the gas consumption/flow by turning the setting screw in steps of a quarter turn.

Clockwise to increase gas consumption/flow.

Counter clockwise to decrease gas consumption/flow.

If you change the gas consumption/flow in this way you have to do this together with the high speed potentiometer in steps of 1V in opposite way. This in order to keep the balance in the CO₂ value.

After this change you always have to measure the toxicity and adjust if necessary.

Note 4: During and after the adjustment you have to check the gas consumption/flow by means of a flow meter.



IGNITION/IONIZATION SET

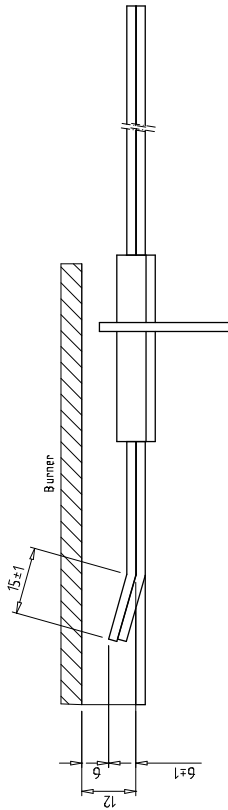
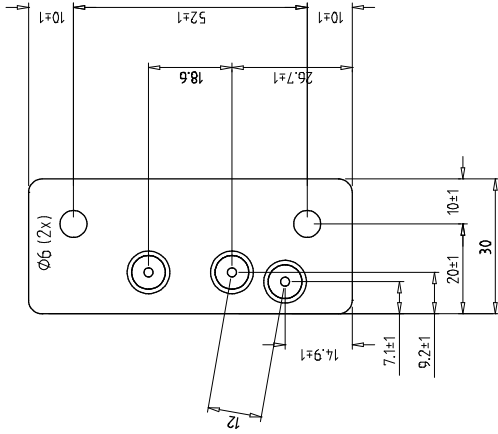
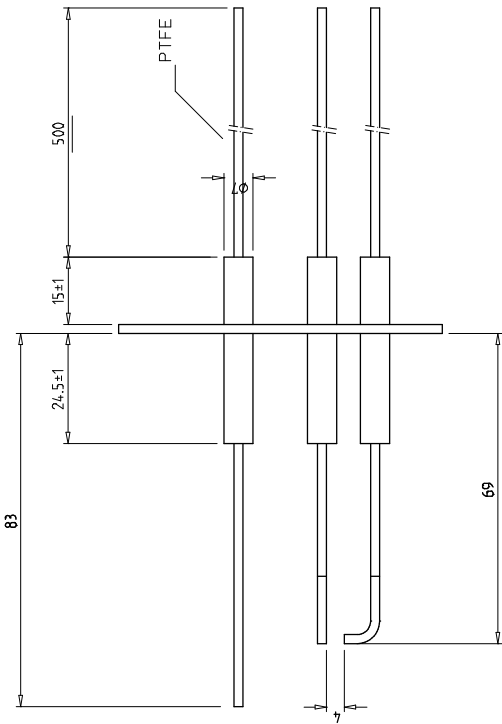

matrícula	cont.	pas.	breve	ordenado m.
atm. general:	Revisión	D		
atm. especial:	Revisión	19-4-2007		
grupos:	x	x	n.º	orden
bestend van:	Eurogrill		orden	
STG	fri-jado		Ignition/Ionisation set	
7	T.Aarts		1:1	
	geplaat		A 3	
	datum		tekening nr.	
	22-08-02		9172200	
specificaties in werkdruk	<p>fri-jado b.v. Postbus 560, 4870 AN Etten-Leur Telefoon: 076-5084500 Fax: 076-5084544 E-Mail: fri-jado@planet.nl</p>			

CONTROL LOCATION

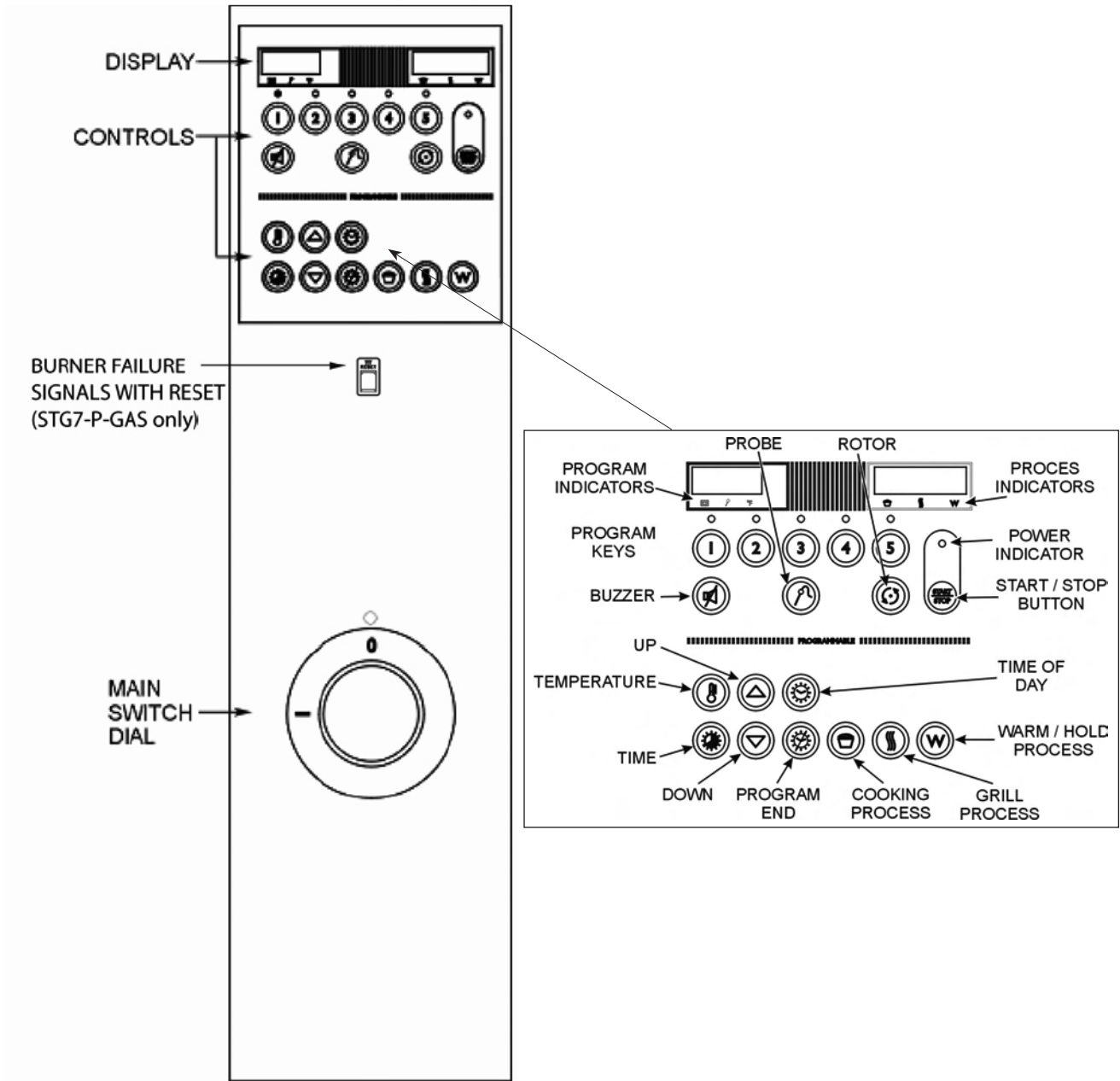

TROUBLESHOOTING FOR THE STG7 P GAS ROTISSERIES

Symptom	Possible causes
No power to oven controls.	<ol style="list-style-type: none"> 1. Main breaker open. 2. Fuse F1 burned. 3. Main switch malfunction. 4. Security thermostat tripped. 5. Wiring loose.
Main fuse or breaker blows.	<ol style="list-style-type: none"> 1. Wiring incorrectly. 2. Drive motor, blower or contactor switch shorted. 3. Wiring shorted.
Drive motor does not run in program mode.	<ol style="list-style-type: none"> 1. Capacitor malfunction. 2. Wiring loose. 3. Main switch malfunction. 4. Motor malfunction.
Blower motor does not run.	<ol style="list-style-type: none"> 1. Capacitor malfunction. 2. Wiring loose. 3. Motor inoperative.
Oven temperature differs from temperature setting in program mode.	<ol style="list-style-type: none"> 1. Safety thermostat malfunction. 2. Blower motor(s) inoperative (turning direction?) 3. Electronic control inoperative. 4. PT-500-sensor malfunction. 5. Dirty fan guard or fan blade(s).
Oven temperature does not reach desired temperature in program mode.	<ol style="list-style-type: none"> 1. Safety thermostat malfunction. 2. PT-500-sensor malfunction. 3. Electronic control inoperative.
No display and/or keypad does not function.	<ol style="list-style-type: none"> 1. Main breaker open. 2. Loose flat cable from display to electronic control. 3. Fuse F4 (63mA) burned. 4. Display and/or electronic control malfunction.
No ignition.	<ol style="list-style-type: none"> 1. Check polarity of plug. 2. Gas burner safety control malfunction. 3. Wiring loose.
Plopping/exploding sound when igniting the gas.	<ol style="list-style-type: none"> 1. Decrease the low speed Voltage on the speed regulation board.
Whistling sound during burning of gas.	<ol style="list-style-type: none"> 1. Slightly reduce the setting screw and increase the high speed Voltage on the speed regulation board.
No ignition of the gas in the burner (reset light is burning).	<ol style="list-style-type: none"> 1. Reset switch malfunction. 2. Gas supply closed. 3. Gas block malfunction. 4. Gas burner safety control malfunction. 5. Wiring loose.
Burner switches on and off intermittently during operation.	<ol style="list-style-type: none"> 1. Reset switch malfunction. 2. Adjustment of ionisation pin. 3. Gas pressure too low (under 13 mbar). 4. Gas burner safety control malfunction.
Gas ignites in burner but cuts off after a short time. (reset light is burning).	<ol style="list-style-type: none"> 1. Ionization pin malfunction. 2. Adjustment of ionization pin. 3. Loose wiring of ionization pin. 4. Gas burner safety control malfunction.
Burner stops during operation.	<ol style="list-style-type: none"> 1. Gas supply blocked. 2. Adjustment of ionization pin. 3. Ionization pin malfunction. 4. Gas burner safety control malfunction. 5. Security thermostat tripped. 6. Wiring ionization pin.
Gas mixture blower only runs in high speed.	<ol style="list-style-type: none"> 1. Speed regulation board malfunction. 2. Rectifier malfunction. 3. Wiring loose.

EMPTY PAGE

EXPLODED VIEWS & PARTLISTS

STG7 P GAS - SHEET IRON WORK

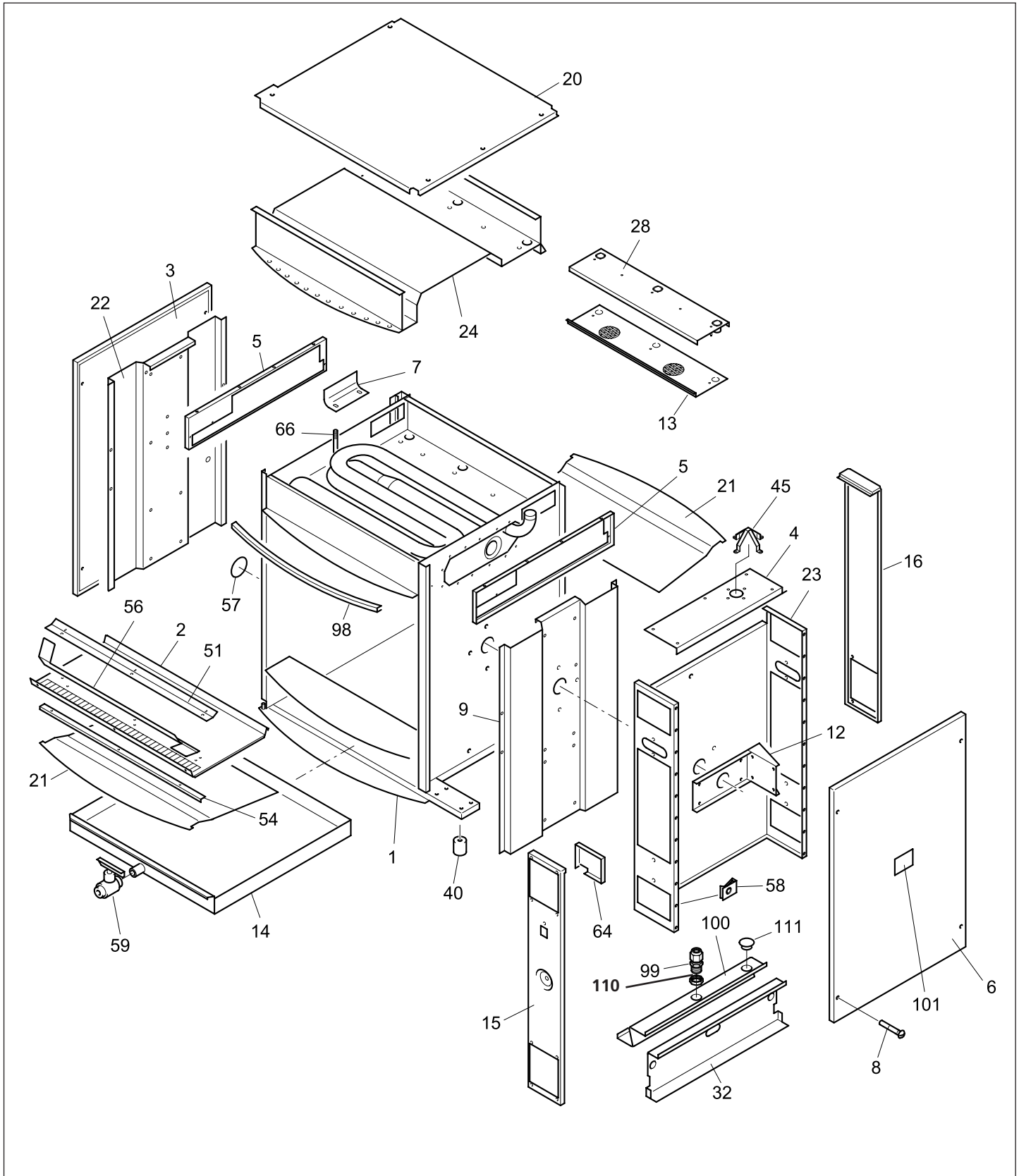

Item	Qty.	Part number	Description
1	1		Frame, ass.
2	1	9174416	Plate, air guide
3	1	9170419	Side panel, left
4	1	9174447	Cover, removable
5	2	9170523	Side panel, top
6	1	9170531	Side panel, right
7	1	9174408	Plate, air guide
8	8	4288322	Screw M5 x 10, SS socket button head
9	1	9170567	Reinforcement, side plate, right
12	1	9170444	Support, gear motor
13	1	9170566	Air guide plate
14	1	9170451	Drawer
15	1	9174682	Operation panel
16	1	9174031	Panel, customer side
20	1	9174045	Cap, top
21	2	9172202	Bottom plate, coated
22	1	9174431	Reinforcement, side plate, left
23	1	9174429	Cover plate, machine components
24	1	9170573	Ceiling
28	1	9170568	Mounting plate, blowers
32	1	9174034	Mounting plate
40	4	9171125	Leg, rubber
45	1	9174485	Cover, exhaust
51	1	9174436	Fastening profile
54	1	9174417	Profile, air guide
56	1	9174427	Profile, air guide
57	4	9112430	Washer, insulation support
58	8	9172053	Nut
59	1	9171008	Drain-tap with handle
64	1	9174146	Protection plate, electric components
66	1	9174446	Bracket, heat exchanger
98	2	9172116	Sealing profile, Silicon L= 71 cm
99	1	9222076	Strain relief M20
100	1	9174140	Spark catcher
101	1	9123439	Indication plate
110	1	9222077	Connector M20
111	1	9171116	Grommet

STG7 P GAS - COMPONENTS

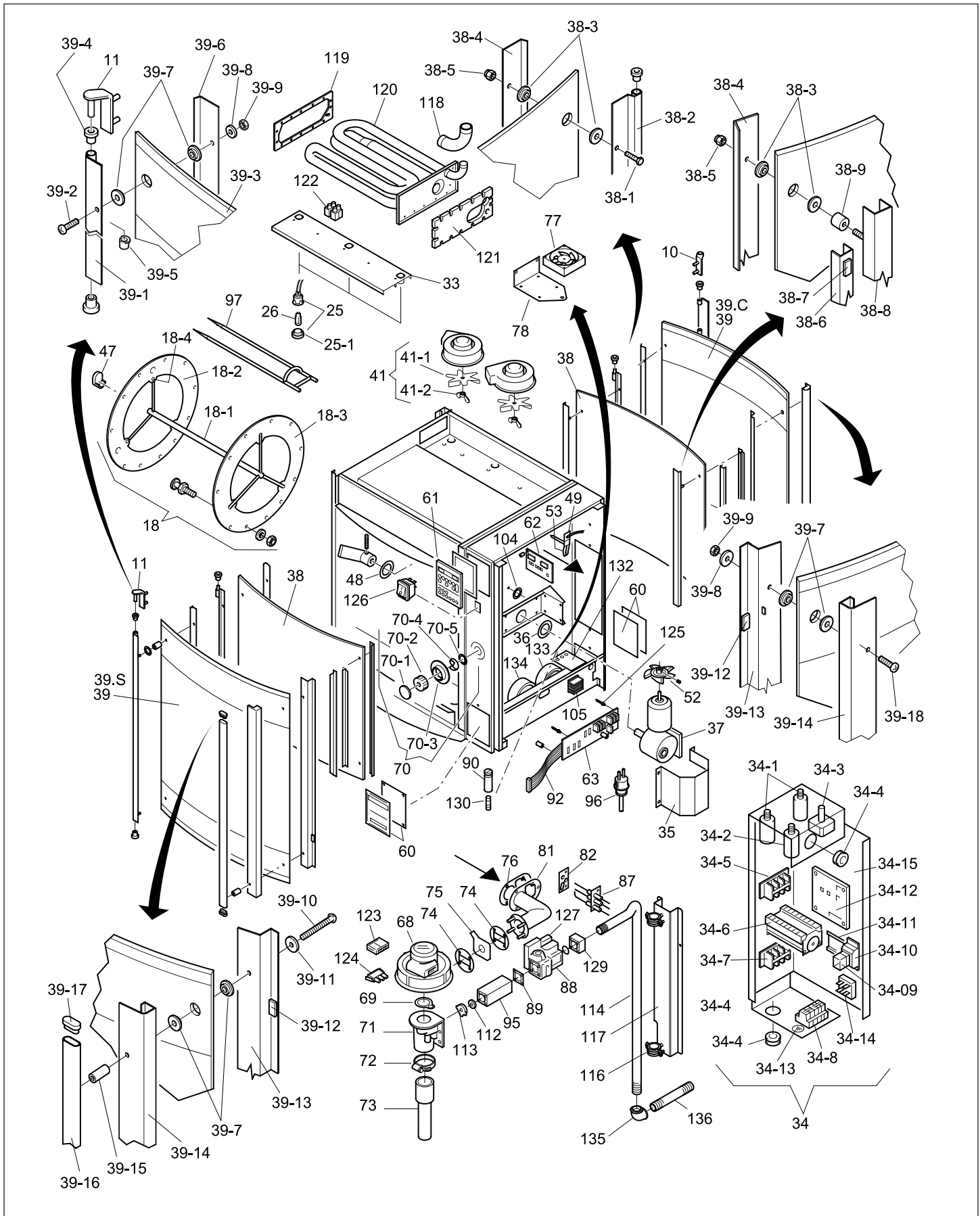

Item	Qty.	Part number	Description
10	1	9170426	Hinge, right
11	1	9170427	Hinge, left
18	1	9170045	Rotorset, ass. coated
18-1	1	9172205	Rotor shaft, ass. coated
18-2	1	9172248	Rotor disc, left, coated, incl. support pins
18-3	1	9172249	Rotor disc, right, coated, incl. support pins
18-4	14	9172252	Tensilock bolt M5x10, coated
25	6	91711355	Lamp holder, incl. glass
25A	6	9171078	Lamp holder, incl. glass (till serial number 100043535)
25-1	6	9171136	Glass lampholder
25-1A	6	9171126	Glass lampholder (till serial number 100043535)
26	6	3701052	Lamp 20W, 12V/300°C
33	2	9112210	Mounting plate, lamp holder
34	1	9173053	Electric panel, ass.
34-1	2	9110030	Capacitor 1,5 mF
34-2	1	9077101	Capacitor 2,5 mF
34-3	1	9040970	Thermostat, 100-320°C
34-4	2	9070840	Grommet
34-5	1	8033659	Connecting block, 9-pol.
34-6	1	9171140	Main switch
34-6A	1	9172347	Main switch (till serial nr. 100052400)
34-7	1	9040722	Connection block 3-pole
34-8	1	9044564	Connecting block, 1,2,3
34-9	1	6390128	Relay 230V, MY4
34-10	1	9171086	Leg, relay
34-11	1	9077088	Rail
34-12	1	9171109	Board, speedcontrol blower
34-13	1	0166555	Earth symbol
34-14	1	9171089	Rectifier
34-15	1	9174108	Electric panel
35	1	9174161	Protection support
36	1	9110797	Sealring, drive bearing
37	1	9173004	Gear motor, complete with drive arm
38	2	91798525	Door inside, ass.
38-1	4	0211520	Bolt M5 x 12 ss hexagon head
38-2	2	9170423	Hinge profile
38-3	16	3702341	Flange bush, PTFE 2 mm
38-4	4	9174029	Cover profile, inner glass
38-5	8	4285408	Nut, M5
38-6	2	9174027	Profile
38-7	20	9070141	Magnet block
38-8	2	9174026	Holder, magnet
38-9	4	9172081	Spacing pin

Item	Qty.	Part number	Description
39.5	1	91798505	Door service side, ass.
39-1	1	9170422	Hinge profile
39-2	2	4288321	Screw M5x16, SS socket button head
39-3	1	9172079	Protection profile
39-4	2	9172054	Brass bearing 8 mm
39-5	2	9172122	Brass bearing 8 mm, adjusted
39-6	1	9174022	Mounting profile, hinge side
39-7	8	3702342	Flange bush, PTFE 3 mm
39-8	2	4311110	Washer
39-9	2	0144359	Nut, self locking M5
39-10	2	4288320	Screw M5x45 SS
39-11	2	9174680	Washer
39-12	12	9070141	Magnet block
39-13	1	9174025	Fastening, door handle
39-14	1	9170454	Profile, magnet
39-15	2	9172300	Spacing pin
39-16	1	9174131	Door handle
39-17	2	9171014	Plug, door handle
39.C	1	91798515	Door customer side, ass.
39-1	1	9170422	Hinge profile
39-2	2	4288321	Screw M5x16, SS socket button head
39-3	1	9172079	Protection profile
39-4	2	9172054	Brass bearing 8 mm
39-5	2	9172122	Brass bearing 8 mm, adjusted
39-6	1	9174022	Mounting profile, hinge side
39-7	8	3702342	Flange bush, PTFE 3 mm
39-8	2	4311110	Washer
39-9	2	0144359	Nut, self locking M5
39-10	2	4288320	Screw M5x45 SS
39-11	2	9174680	Washer
39-12	12	9070141	Magnet block
39-13	1	9174025	Fastening, door handle
39-14	1	9170454	Profile, magnet
39-18	2	4288321	Screw M5 x 16 , ss socket button head
41	2	9140027	Blower
41-1	2	9141934	Fanblade
41-2	2	9073150	Wingnut, left hand threaded
47	1	9172063	Steel bearing, 14 mm
48	1	9073131	Sealing ring
49	1	9070094	Temperature sensor
52	1	2000072	Fanblade, gearmotor
53	1	9044140	Sensor cable
60	2	9172040	Name plate Fri-jado, foil + backplate
61	1	9172045	Keypad + backplate
62	1	9110242	Display
63	1	9110276	Power section
68	1	9171090	Gas mixture blower
69	1		See item 71
70	1	9173017	Main power knob assembly

Item	Qty.	Part number	Description
70-1	1	9172049	Cover, knob
70-2	1	9172021	Control knob, grey
70-3	1	9172037	Back plate, main switch 0-1
70-4	1	9172052	Locking ring, knob
70-5	1	9110802	Plug, TG
71	1	9171094	Venturi tube, incl. gasket item 69.
72	1	0156712	Clamp, tube 50-65
73	1	9170050	Silencer
74	2	9172184	Gasket, burner, Fiberfrax 4 mm
75	1	9174497	Air inlet G 20/25
75	1	9174491	Air inlet G 31
76	1	9172183	Gasket, Fiberfrax 4 mm
77	1	3500031	Blower
78	1	9294200	Mounting plate, blower
81	1	9170587	Coupling tube
82	1	9172198	Gasket, ignition set, Fiberfrax 2 mm
87	1	9172200	Ignition/ionization set
88	1	9171093	Gas control block
89	1	9172266	Gasket, gas control block, Viton 1 mm
90	2	9044205	Fuse holder HPS-EE
92	1	9172113	Flatcable, 34-pol. (P)
95	1	9172179	Connecting piece
96	1	9088796	Connecting cable with plug Nema 5-15
97	7	9172242	Meatfork STG, coated (8mm)
104	3	9171018	Plug

Item	Qty.	Part number	Description
105	1	9151010	Connecting block
112	1	9174498	Orifice 4,2 mm (G20/25)
112	1	9174492	Orifice 3,4 mm (G31)
113	1	9171099	Holder, orifice
114	1	9173071	Gas tube 1/2"
116	2	2650267	Pipe Clamp 14/20
117	1	9175230	Mounting profile
118	1	9292107	Insulation exhaust pipe
119	1	9174481	Gasket, Kerasil 4 mm
120	1	9170588	Heat exchanger + burner
121	1	9174484	Insulation plate
122	4	2300121	Connecting block, ceramic
123	1	9171111	Connector 5-pole
124	1	6501445	Connector 3-pole
125	8	9110028	Spacing pin
126	1	9171057	Reset switch
127	1	9171079	Gas burner safety control
129	1	9171092	Flange + gasket
130	2	9044213	Fuse SC3, ceramic 3A
132	1	9174398	Fuse holder plate
133	1	9171049	Ring core transformer
134	1	9171056	Ring core transformer 115V / 230V
135	1	9171053	Knee joint 1/2"
136	1	9173072	Pipe nipple, G1/2" - 1/2"NPT L=130 mm

ELECTRICAL DIAGRAMS

STG7 P GAS - CIRCUIT DIAGRAM

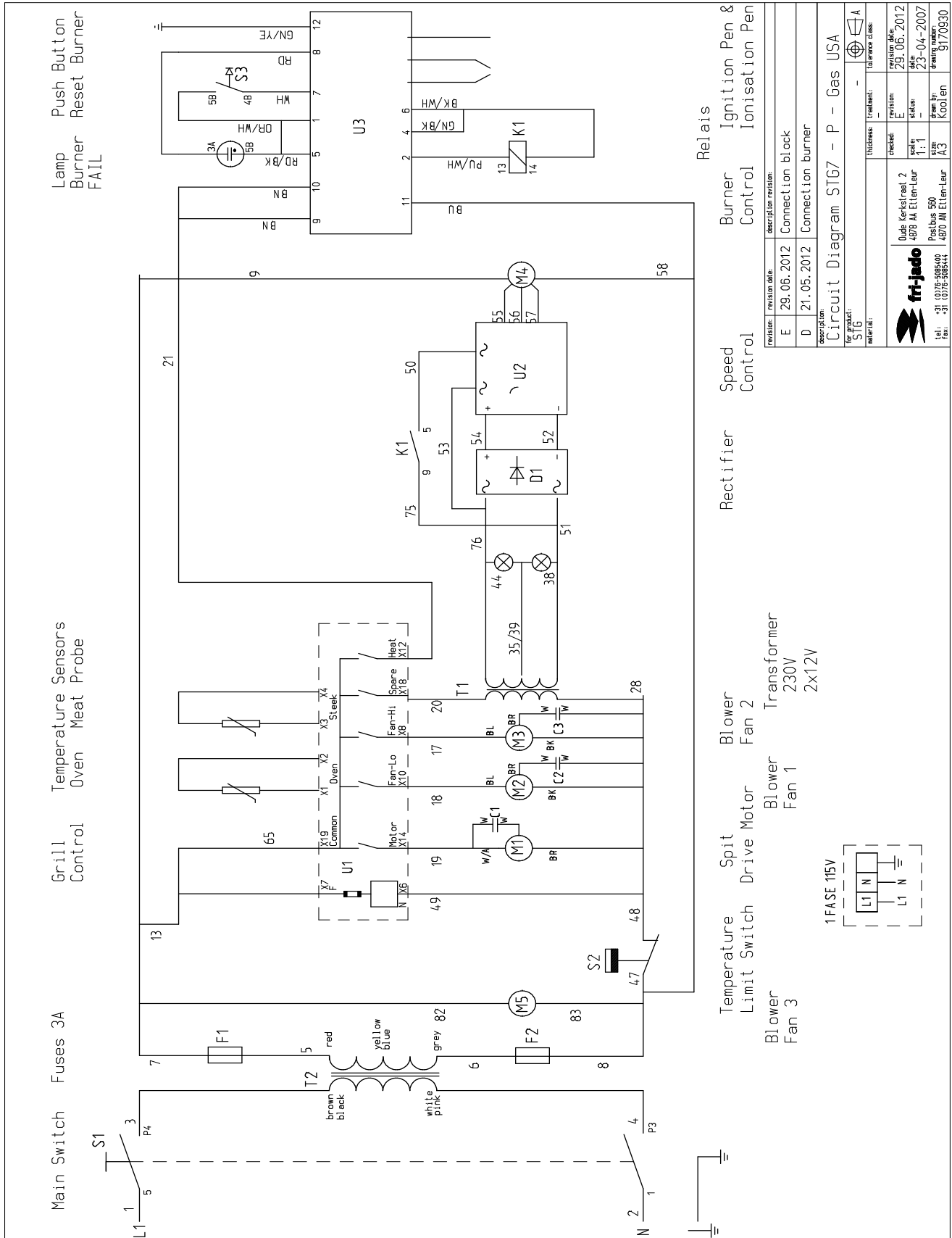

revision	revision date	description revision
E	29.06.2012	Connection block
D	21.05.2012	Connection burner

description
Circuit Diagram STG7 - P - Gas USA

for product	material	drawings	treatment	revision	revision date	revision status	revision by	revision date
STG								

Oude Kerckstraal, 2
 4878 AA Etten-Leur
 Postbus 560
 Tel.: +31 (0)76-5085100
 Fax: +31 (0)76-5085111
 4870 AN Etten-Leur
 9170930

STG7 P GAS - WIRING DIAGRAM

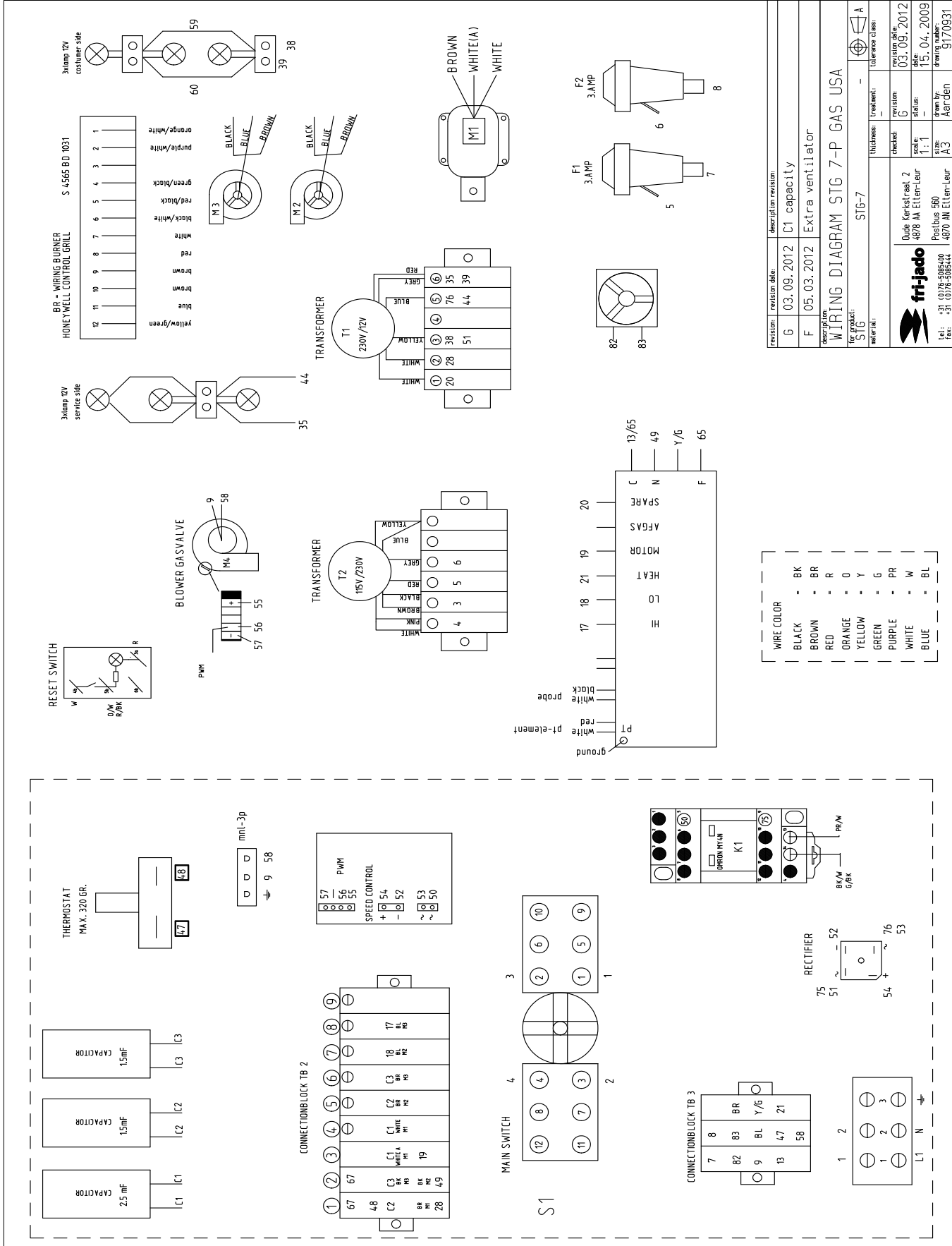

STG7 P GAS - WIRING DIAGRAM (TILL SERIAL NUMBER 100054530)

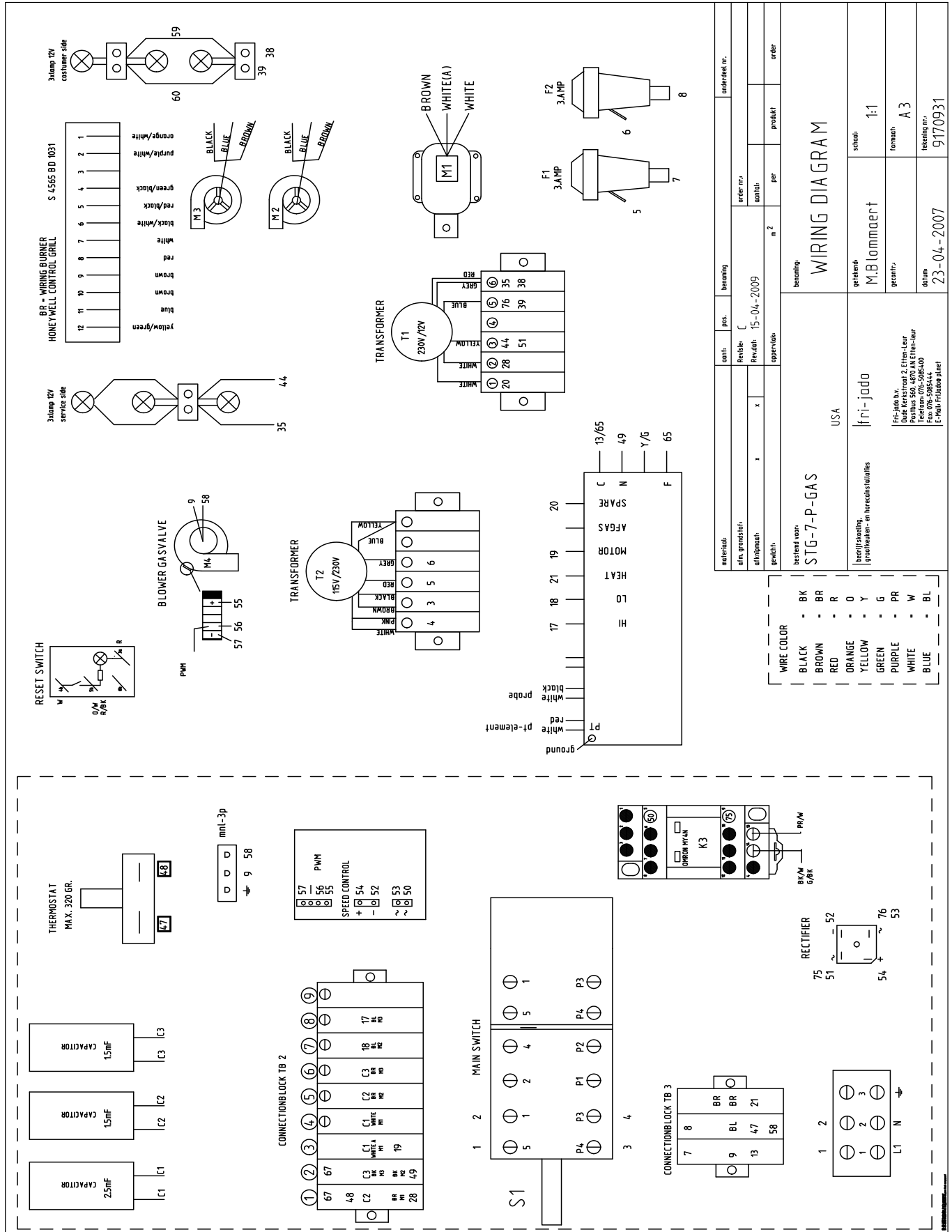

material:	amt:	pos:	besch:	onderzet nr.:
afn. goedertij:	Revizie:	C		order nr.:
afwijkingen:	Revisie:	15-04-2009		aanst:
gewicht:	opmerking:	m 2		per
				produkt
				order

bestand van:	benaming:
STG-7-P-GAS	WIRING DIAGRAM
USA	
fri-jado	getekend:
	M.B. lommaert
	schaal:
	1:1
	formaat:
	A3
	tekening nr.:
	23-04-2007
	9170931

EMPTY PAGE

For technical support call: 877 374-5236
For parts call: 877 392-7851

