

SERVICE MANUAL

TDRac



- NOTICE -

This manual is prepared for the use of trained Service Technicians and should not be used by those not properly qualified. If you have attended a training for this product, you may be qualified to perform all the procedures in this manual.

This manual is not intended to be all encompassing. If you have not attended a training for this product, you should read, in its entirety, the repair procedure you wish to perform to determine if you have the necessary tools, instruments and skills required to perform the procedure. Procedures for which you do not have the necessary tools, instruments and skills should be performed by a trained technician.

Reproduction or other use of this Manual, without the express written consent of Fri-Jado, is prohibited.



EMPTY PAGE

INDEX

Index..... 4

TDR-ac Installation..... 6

 TDRac, technical data..... 6

 Introduction 8

 Unpacking the unit 8

 Location..... 9

 Electrical supply 9

 Factory

 default ! 9

 European models 9

 Factory

 default ! 9

 American models 9

 Legs / Castors 10

 Tethering of the unit..... 10

 Power, Water and Drain connections 11

 Water Requirements 11

 Connecting the drain tube 12

 Extraction of the rotisserie..... 12

 grease Collection 13

 Test run 13

 Instructions for operators 13

 TDR ac on Stand..... 14

 TDR ac Hood 15

Software 16

 Default parameters Version 6.01.00 TDRac (mark III)..... 16

Exploded views and partslists 18

 TDRac, Electrical parts 18

 TDRac, Partslist Electrical parts..... 19

 TDRac, Doors 20

 TDRac, Partslist Doors..... 21

 TDRac, Rotor 22

 TDRac, Partslist Rotor 23

 TDRac, Blower & Heating 24

 TDRac, Partslist Blower & Heating 25

 TDRac, Cleaning system 26

 TDRac, Partslist Cleaning system..... 27

 TDRac, Sheet metal..... 28

 TDRac, Partslist Sheet metal 29

 TDRac, Underframe 30

 TDRac, Partslist Underframe 31

Electrical diagrams 32

 Circuit diagram TDRac (mark III) 32

 Wiring diagram TDRac (mark III) 33

 Circuit diagram TDRac (mark II) 34

 Wiring diagram TDRac (mark II) 35

 Circuit diagram TDRac (mark 1) 36

 Wiring diagram TDRac (mark 1) 37

EMPTY PAGE

TDRAC, TECHNICAL DATA

Consult the identification plate to get the proper specifications of the unit. The electrical data may vary from country to country.

European models

Dimensions	Width	mm	1045
	Depth	mm	975
	Height	mm	1795
Weight	Gross	kg	300
	Net	kg	250
Maximum ambient temperature		°C	35
Sound pressure		dB (A)	< 70
Electrical installation	Voltage	V	3N ~ 400/230
	Frequency	Hz	50/60
	Required power	kW	10.5
	Max. nominal current	A	16
Plug	CEE-form	A	16
	Length	m	approx. 2.2
Water connection	Aerated	inch	¾
Water	pressure	kPa	200 – 500
	Acidity	pH	7.0 - 8.0
	Chlorides	ppm	<30
	Hardness ¹	dH	<4
Drain	Open connection	mm	min. 40

¹ See chapter “water requirements” for detailed information

American models

Dimensions approx.	Width	inch	41
	Depth	inch	38½
	Height	inch	70½
Weight	Gross	lbs	662
	Net	lbs	552
Maximum ambient temperature		°F	95
Sound pressure		dB (A)	< 70
Electrical installation	Voltage	V	3 ~ 208
	Frequency	Hz	50/60
	Required power	kW	12
	Max. nominal current	A	35.5
Plug	NEMA		15 - 50P
	Length	inch	75
Water connection	Aerated	inch	¾
Water	pressure	kPa	200 – 500
	Acidity	pH	7.0 - 8.0
	Chlorides	ppm	<30
	Hardness ¹	dH	<4
Drain	Open connection	inch	min. 1 5/8

¹ See chapter “water requirements” for detailed information

INTRODUCTION

- Unpacking of the unit.
- Remove the pallet under the unit with the help of a fork lift.
- Put the unit on his location.
- Check if there is enough free space around the unit (see installation drawing).
- Check the electrical supply.
- Tethering of the unit.
- Connect the water.
- Connect drain.
- Grease collection.
- Make a test run on 250 °C.
- Give instructions to the operator.

UNPACKING THE UNIT

Immediately after unpacking the oven, check for possible shipping damage. If the oven is found to be damaged, save the packaging material and contact the carrier.

The standard way to remove the oven from a pallet is with a fork lift.

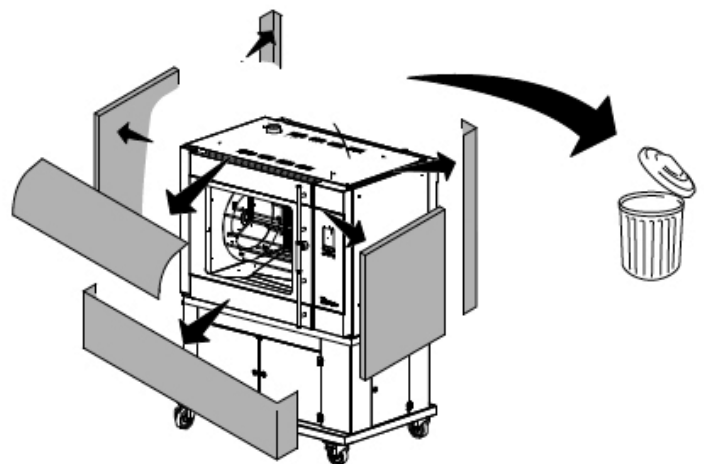
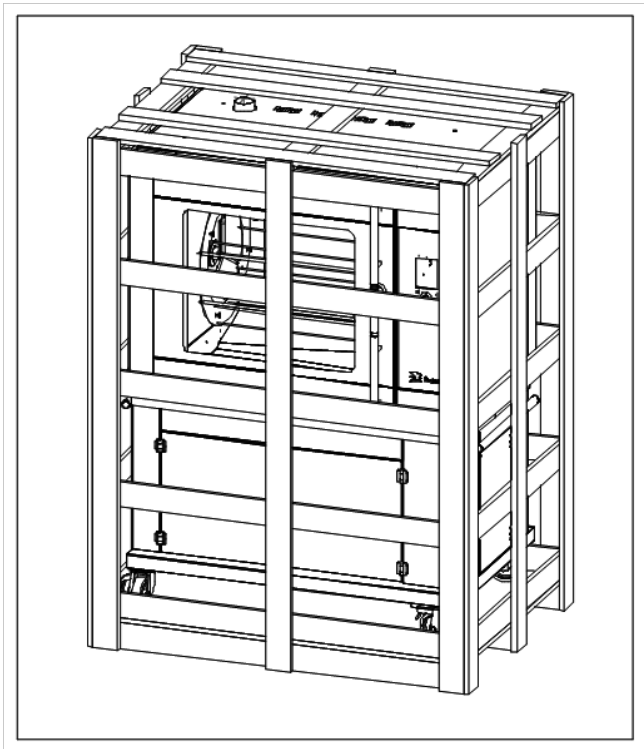

LOCATION

The oven must be installed on a level surface. The installation location must allow adequate clearances for servicing and proper operation.

IMPORTANT: Make sure you leave sufficient space around the rotisserie to easily remove or insert the rotor. If the base has (rotating) wheels, the floor on which it rests must be level.

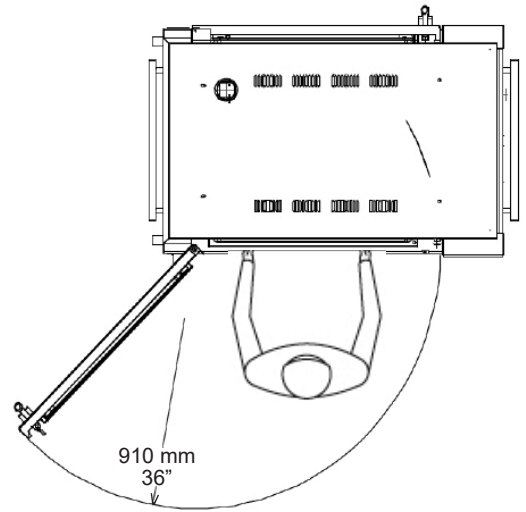

ELECTRICAL SUPPLY

Prior to installation, test the electrical service to assure that it agrees with the specifications on the machine data plate located on the right side panel near the controls. The connecting cable for the unit must be equipped with an approved plug connection. If use is to be made of a permanent connection, the connecting cable must be connected to a manual on/off switch that is installed near the unit in a clear visible manner.

The unit must be connected according to one of the the figures below.

**FACTORY
DEFAULT !
EUROPEAN MODELS**

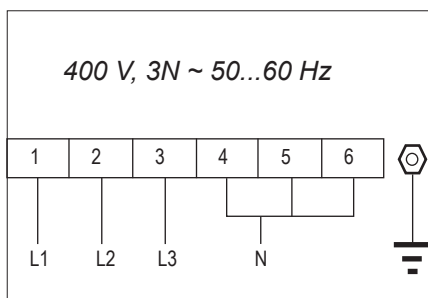

**FACTORY
DEFAULT !
AMERICAN MODELS**

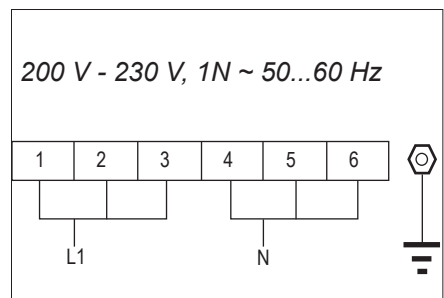
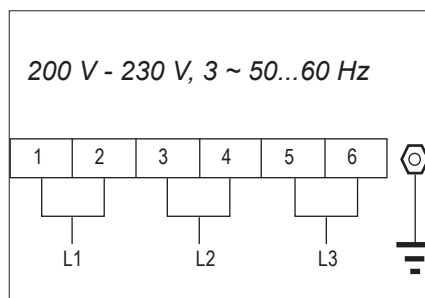

LEGS / CASTORS

The TDR ac is placed on a stand with 2 swivel and 2 locking swivel castors.

TETHERING OF THE UNIT

Warning: Safety standards require that, when this appliance is properly connected to the electrical power supply using flexible conduit, adequate means be provided to limit movement of the appliance without depending on or transmitting stress to the electrical conduit. This means that, as part of the installation, the base or bottom unit of stacked models must be secured to the building structure (typically either wall or floor) to limit the movement of the appliance and, thus, helping to prevent damage to the conduit during cleaning, maintenance and service operations.

A tether bracket, as shown on the drawing below, is provided with the stand. Based on the routing of the flexible conduit, the bracket must be installed along with the caster to one corner of the base using the hardware provided. The remaining open hole in the center of the tether bracket is to be used to secure one end of the tether (locally supplied chain, cable, etc.). The other end of the tether is to be secured to an anchoring point in the building structure.

Note: *Length of tether must be shorter than the flexible conduit to make sure that during appliance movement, no stress is transmitted to the conduit.*

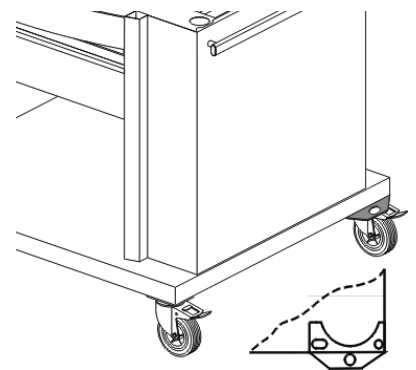

POWER, WATER AND DRAIN CONNECTIONS

The Power, water and drain connections can be found on the back of the unit.

400 V European models

Power connection

Cee form 16 A,

L= 2,5 mtr (98")

200-230 V USA models

Power connection

NEMA 15-50

Water supply hose

G 3/4", L= 1,1 mtr (43")

Drain hose, Ø 27 x Ø 20, L= 1,2 mtr

(Ø 1 1/16" x Ø 13/16", L= 47")

See chapter "connecting the drain tube" for further information.

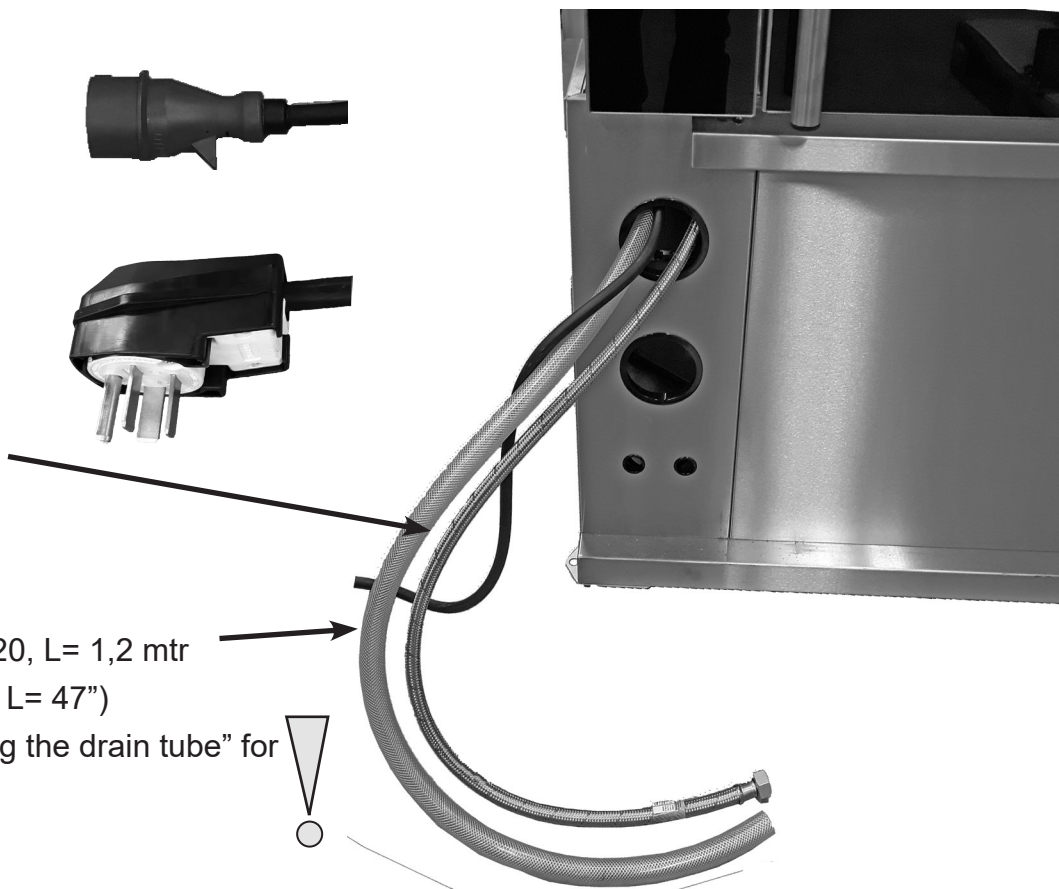

WATER REQUIREMENTS

The supplied tap water must have the following conditions:

1. Minimum pressure 200 kPa (2 bar)
2. Maximum pressure 500k Pa (5 bar)
3. Maximum water temperature 55 °C (130 °F)
4. Acidity pH 7.0 - 8.0
5. Chlorides less than 30 ppm
6. Use a sediment pre-filter or a strainer for the reduction of silica and other non-dissolved sediments.

Water hardness and descaling filters.

7. A descaling filter is advised when the hardness of the water is > 4° dH (4 Grains/Gal).
8. A descaling filter is mandatory when the hardness of the water is > 20° dH (20 Grains/Gal).

Note that the cleaning capacity of the cleaning tablets will decrease with harder water.

The by-pass of the descaling filter, if applicable, needs to be adjusted to zero.

Refer to the filters manual to determine the filter capacity. This filter capacity needs to be adjusted in the manager parameters.

CONNECTING THE DRAIN TUBE

An open draining system with a 110 mm (4 1/2") funnel is recommended. The drain tube has an outside diameter of 33 mm (1 1/3").

- It is not allowed to make a closed connection!
- Make sure that the tube is not kinked and is sloping downwards to the drain funnel.
- The minimum inside diameter of the sewer pipe needs to be 40 mm (1 1/2").
- A siphon in the customers sewer is highly recommended to prevent odors from coming out of the sewer.
- See below examples.

Possible lay outs of drain

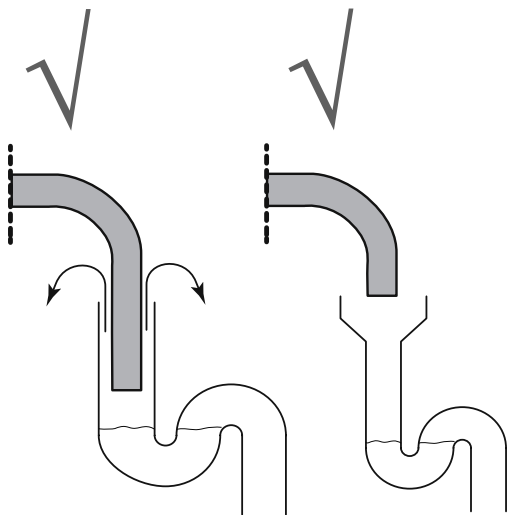

Faulty lay outs of drain

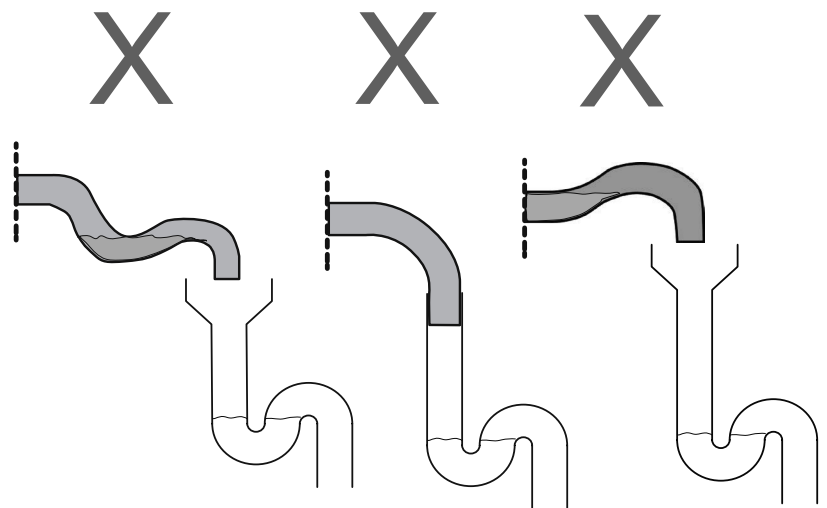

EXTRACTION OF THE ROTISSERIE

An extraction hood is prescribed when the unit is NOT delivered with the special Fri-Jado extraction hood mounted on it.

The TDR produces about 10 m³ (350 cf) vapour during a cooking cycle. When placing the rotisserie under an extraction hood, the following guide lines have to be considered:

- The minimum capacity of the extraction hood has to be 800 m³/h (25000 cf/h).
- The extraction hood has to extend minimum by 20 cm (8") on all sides of the rotisserie.
- The extraction hood has to have a free height, above the rotisserie, of a minimum of 30 cm (12").
- The rotisserie has to be accessible for service purposes.
- The extraction hood has to have facilities to drain any condensation, down to a drain.

GREASE COLLECTION

Place the bucket, which is delivered with the unit, inside the stand under the drain pipe.

It is also possible to put other containers in the underframe to collect the grease.

Note 1: In one run, 5 liters (1,3 gallon) grease can come out.

Note 2: The temperature of the grease can go up to 80 °C (176 °F).

Make sure that the container meets the above requirements.

TEST RUN

The oven must be burned in to release any odours that might result from heating the new oven surfaces. Operate the oven at maximum temperature setting of 250 °C for 30 minutes. Smoke with an unpleasant odour will normally be given off during this burn-in period.

INSTRUCTIONS FOR OPERATORS

After installation of the rotisserie the operator of the unit has to be instructed.

The instruction has to cover the following subjects:

- Programming and options.
- Working of the unit.
- Free space of unit for cooling of drive motor and blowers.
- Run through the user manual.
- How to run the cleaning program and placing cleaning tablets.
- Cleaning of the tablet dispenser and bottom filters after the cleaning program has finished.
- Periodical maintenance:
 - o Cleaning of fan plate every 3 month.
 - o Yearly maintenance by service agent.
- How to react for information or service calls.

TDR AC ON STAND

- ① Location of mains connection
- ② Location of water connection G 3/4" BSP
- ③ Location of drain hose Ø 27 mm (1 1/16")
- ⑥ Minimum required space
- ⑧ Example of funnel
- ⑨ Sewer pipe > Ø 40 mm (1 5/8")

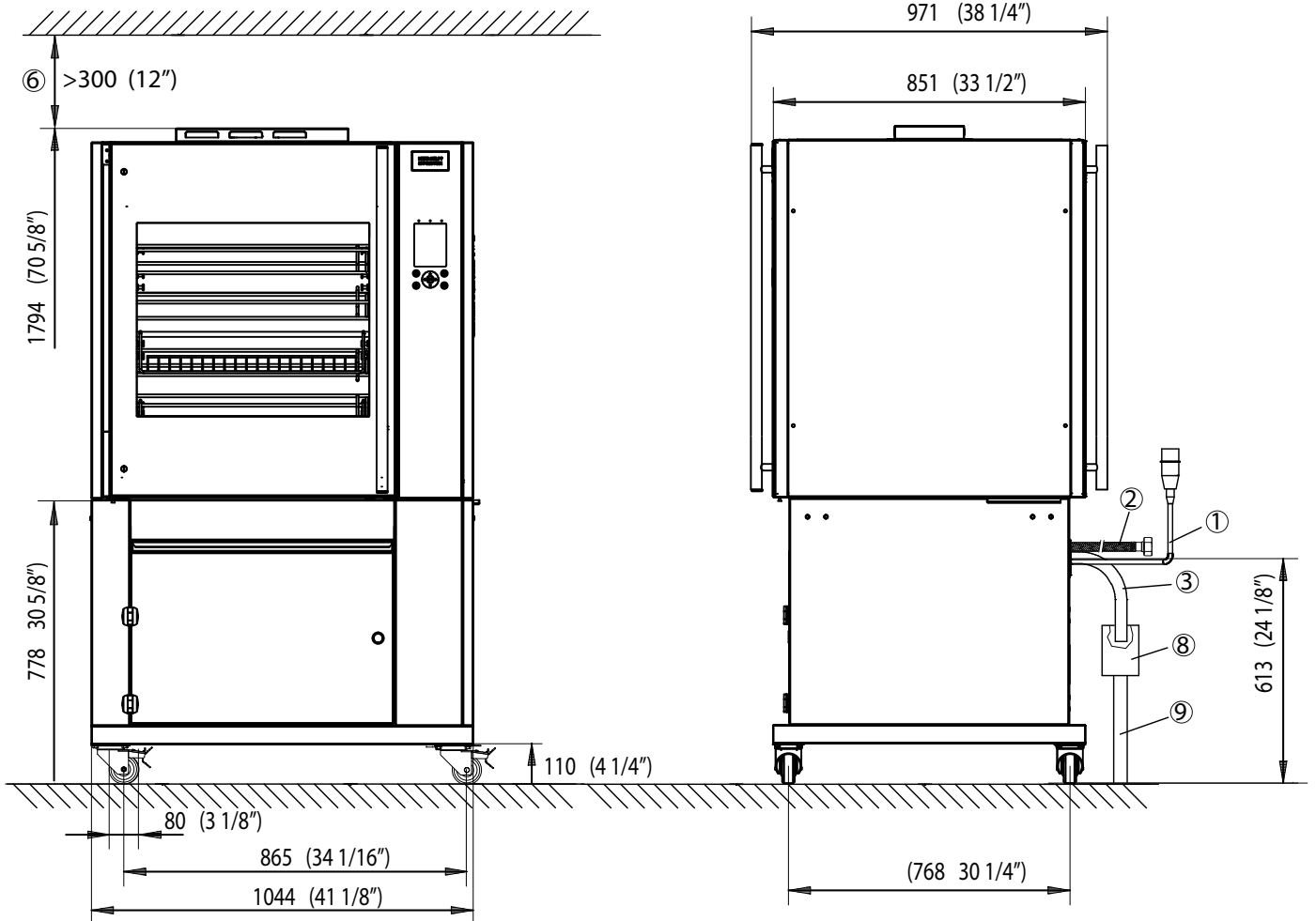
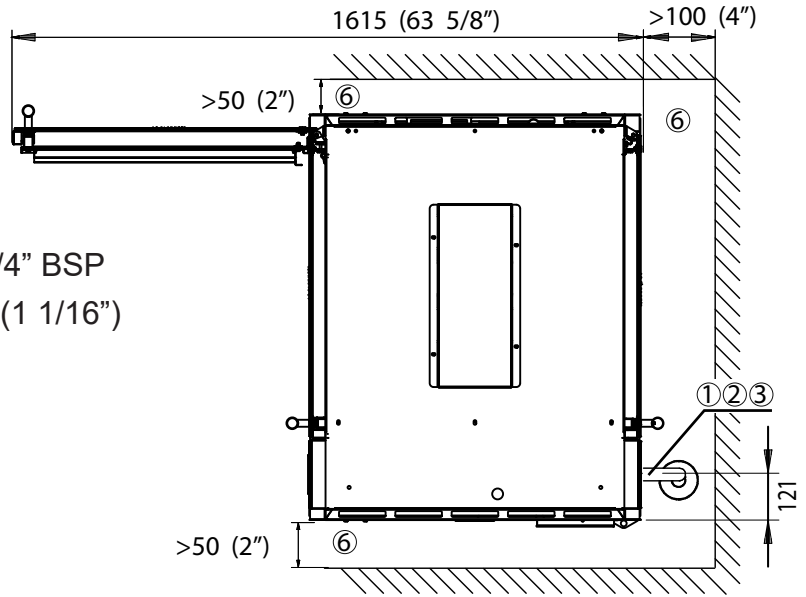

TDR AC HOOD

- ① Location of mains connection
- ② Location of water connection G 3/4" BSP
- ③ Location of drain hose Ø 27 mm (1 1/16")
- ⑥ Minimum required space
- ⑧ Example of funnel
- ⑨ Sewer pipe > Ø 40 mm (1 5/8")

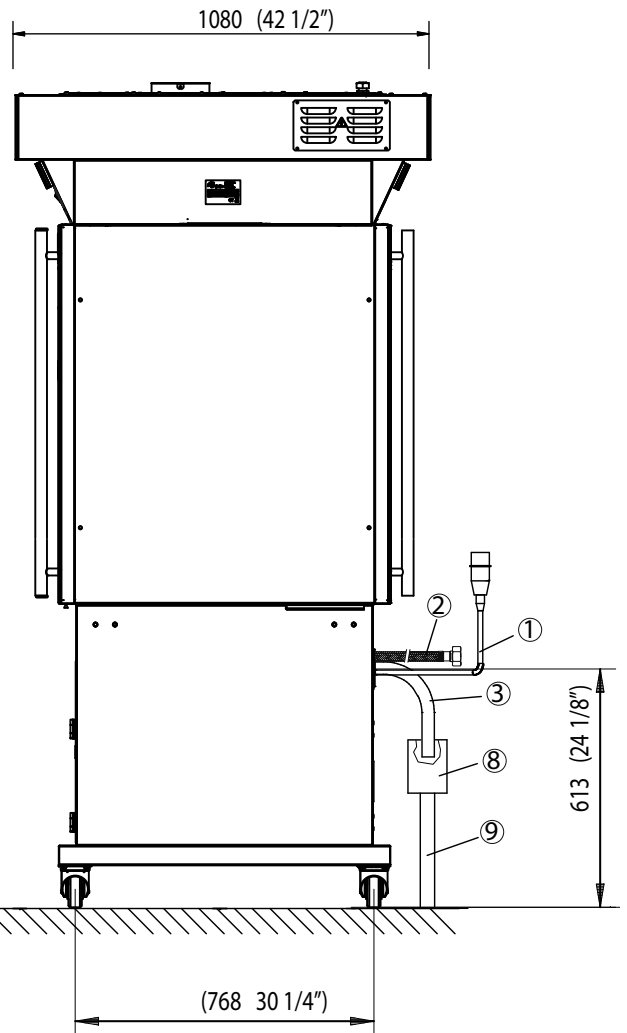
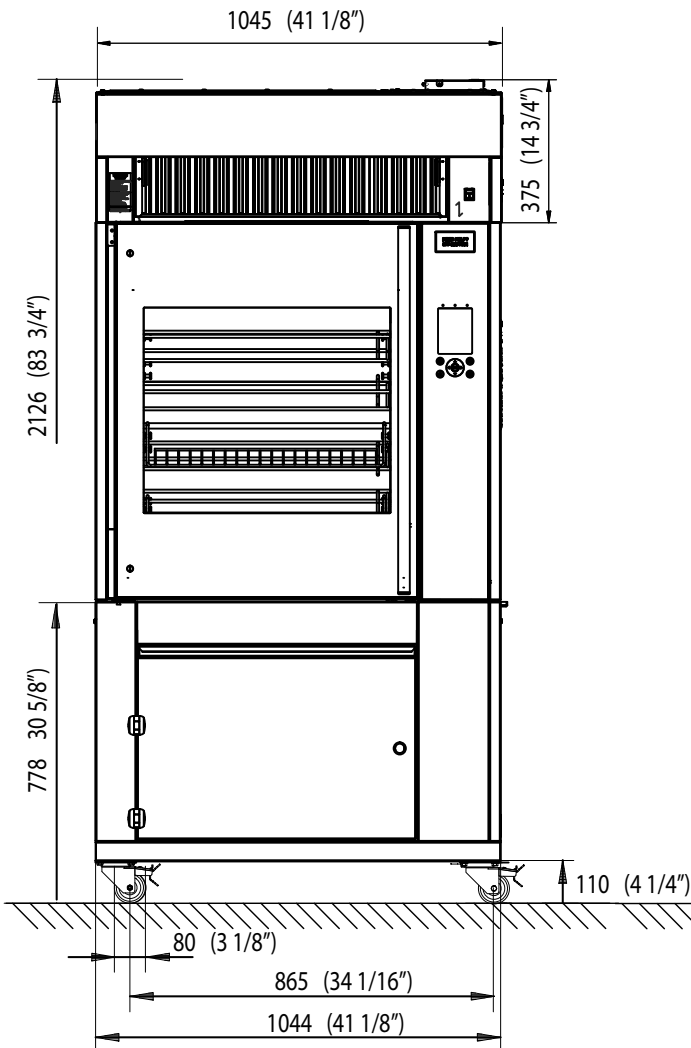
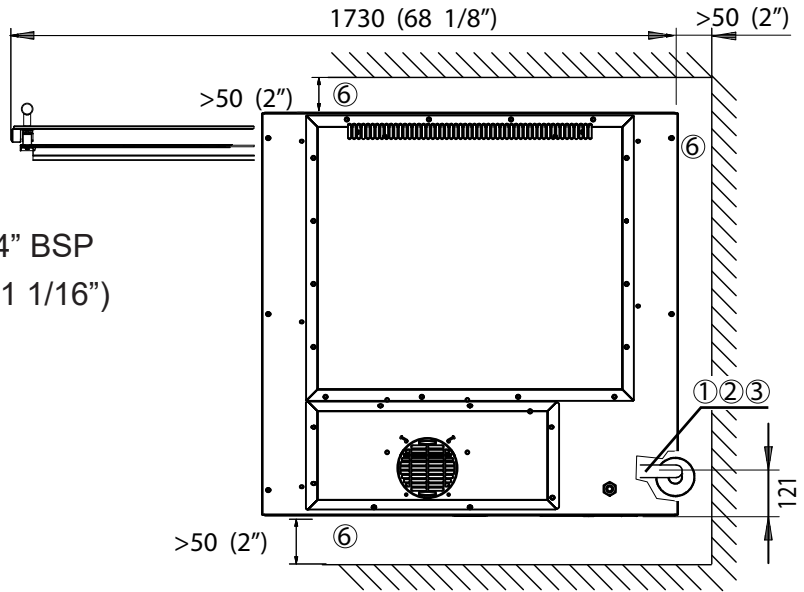

Level 1	Level 2	Level 3		Default	Possibilities
Information				6.01.00	software version
Manager					
	Change Pin code			0000	0000 - 9999
	Save Recipes				save cookbook to USB
	Load Recipes				load cookbook from USB
	Load messages				
	Light			on	on - off
	Temperature			°C	°C - °F
	Unit			lit	lit-gal
	Set time			Local time	
	Set date			Actual date	
	Time format			24 hr	24 hr - AM/PM
	Date format			DMY	DMY - MDY
	Alarm signal			yes	no - yes
	Preheat mode			yes	no - 1x - yes
	Preheat delta			0	-50°C to + 50°C or -90°F to +90°F
	Auto recipe start			yes	no - yes
	Buzzer set			0	0 - 4
	key beep			yes	no - yes
	water capacity filter			-	50 - 30000 or "-" for infinite
	Lime filter				Remaining capacity of lime filter
	Lime filter replaced			no	no - yes
	Clear error				no - yes
Service				4878	
	device type			TDRi	STGi, Multi, BSi, STOi, TRC, ACR, TDRi
	auto-correct			time	no - time
	set language			english	englisch - deutsch - francais - nederlands - espanol - japanese - danish - italiano - russian
	Manual Operation			no	no - yes
	error history				overview of last 200 errors
	save error history				save error history on usb
	clear error history				
	correct-factor			3x	1x - 10x
	debug rs232			no	no - yes
	demo mode			no	no - yes
	demo parameters				
	auto off			60 min	no or 10 - 240
	pin code			****	read out of the manager pin code
	Sensor offset			0 °C	-5°C - 5°C

Level 1	Level 2	Level 3		Default	Possibilities
	Fat drain open			open	open - programmed
	Drain time			40 sec.	10 - 40
	Clean Cycle			2	2 - 4
	Clean temp	Clean temp		55 °C	25 - 60
		Cool temp		75° C	25 - 100
	Clean Times	Rinse heat time		20 min	5 - 40
		Rinse time		10 min.	5 - 40
		Drain time		3 min	2 - 10
		Rinse B time		10 sec	5 - 60
		Drain B time		2 min	1 - 5
		Final time		1 min	1 - 15
	Clean water supply	Clean cycle 1		35 sec	1 - 120
		Clean cycle 1		60 sec	1 - 120
	Complete cleaning			yes	no - yes
	Delete all programs				no - yes
	PID factors	P		100	0 - 100
		I		5	0 - 100
		D		100	0 - 500
		iMax		100	10 - 300
		Relay actions:		80	16 - 160
	Energy	Volts		230	1 - 260
		Model		TDR	TDR
	I/O test				read the inputs and set the outputs
	Ignore errors			no	no - yes
	save HACCP log				save haccp log on usb
	save parameters				save parameters on usb
	load parameters				load parameters from usb

TDRAC, ELECTRICAL PARTS

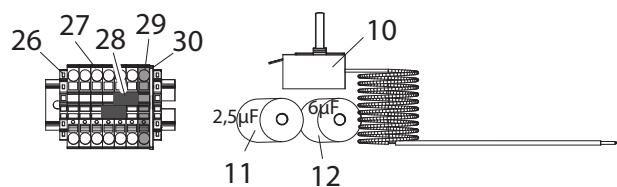
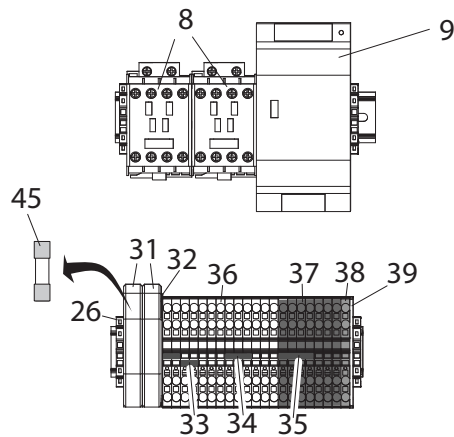
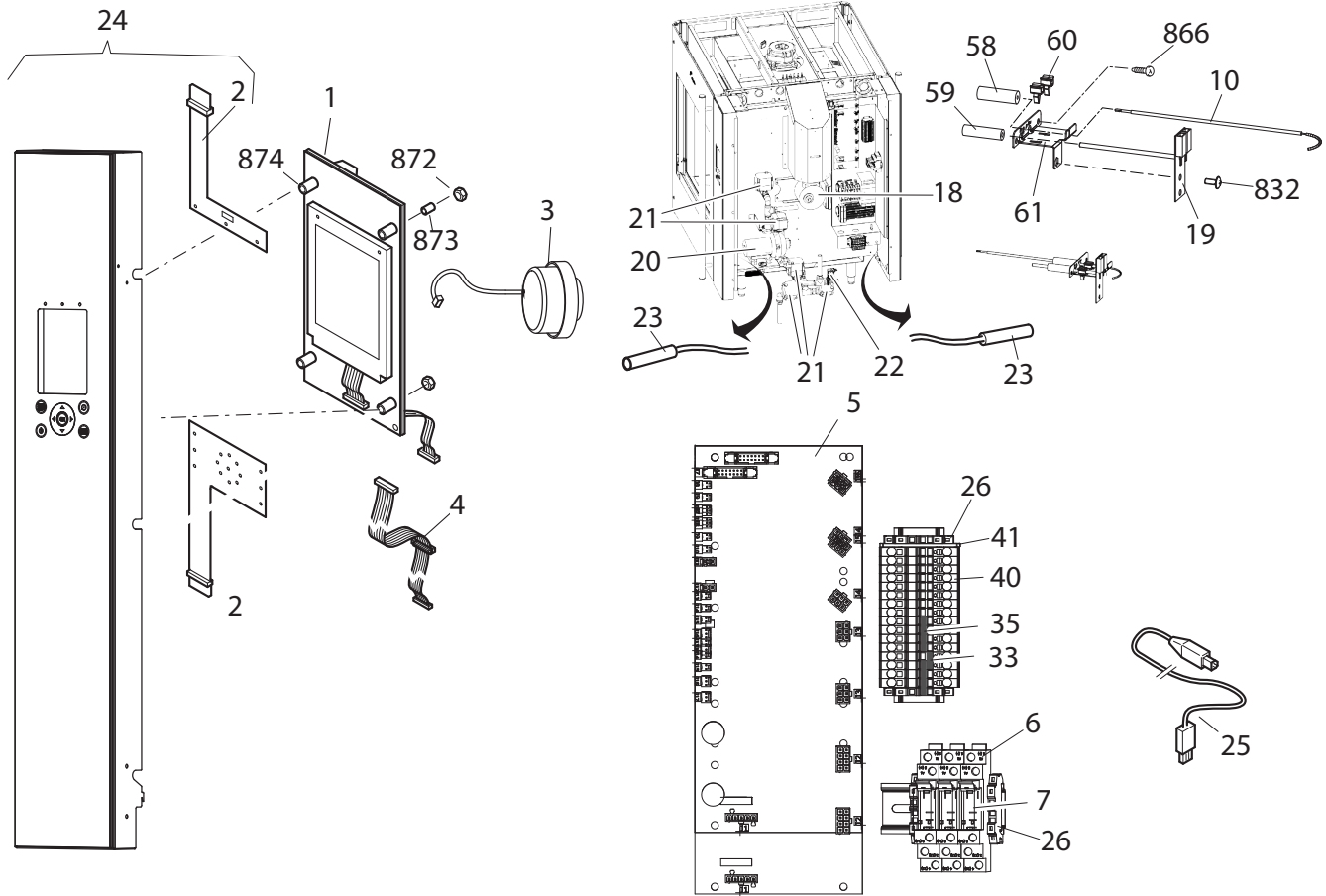
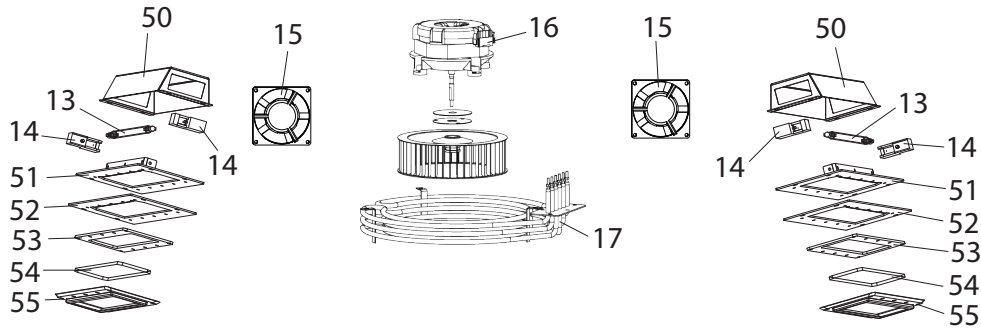

TDRAC, PARTSLIST ELECTRICAL PARTS

Pos	Part number	Description	Qty	Unit	Priority
1	9172552s	CPU + LCD + cable	1		
2	9172329	Keypad, set of 2	1		
3	9172362	Buzzer 12V	1		
4	9172314	Ribbon cable 14p	1		
5	9192400s	Power & I/O board	1		
6	9291141	Socket, relay Allen Bradley	3		
7	9291140	Relay Allen Bradley	3		
8	3500069	Contactora	2		
9	9311016	Power Supply 24V 5A	1		
10	9040970	Thermostat	1		
11	9077101	Capacitor 2,5µF	1		
12	9192034	Capacitor 6µF	1		
13	9291001	Lamp 500W	2		
14	9311015	Lamp holder R7s ceramic	4		
15	8091005	Fan	2		
16	9293020	Blower	1		
17	9292018s	element 9300 W			
17	9302045s	Heating element 10,8kW 208V	1		
18	9310070	Gearmotor, complete with drive head	1		
19	9172310	Temperature sensor PT 1000	1		
20	9311006	Pump	1		
21	9311008	Motor valve -2/2 1/2" CR03			
21	9311023	Motor valve -2/2 1/2" CR02	5		
22	9311007	Solenoid valve E 2/2 - 1/2"	1		
23	3500020	Reed switch	2		
25	9291012	USB cable	0		
26	9191222	End Clamp Clipfix 35-5 PHX	10		
27	9191352	Terminal PT 6 (GY) 6 qmm PHX	6		
28	9191355	Plug-in bridge FBS 2-8 PHX	2		
29	9191353	Terminal PT 6 PE (GN/YE) 6 qmm PHX	1		
30	9191354	End Cover D-PT 6 PHX	1		
31	9191218	Fuse holder Euro ABB	2		
32	9191250	Cap end, for fuse holder	1		
33	9191238	Plug-in bridge FBS 2-6 PHX	3		
34	9191237	Plug-in bridge FBS 3-6 PHX	1		
35	9191236	Plug-in bridge FBS 4-6 PHX	3		
36	9191240	Terminal PT 4 (GR) 4 qmm PHX	13		
37	9191241	Terminal PT 4 (BU) 4 qmm PHX	7		
38	9191239	Terminal PT 4 PE (GN/YE) 4 qmm PHX	1		
39	9191223	End Cover D-PT 4 PHX	1		
40	9191232	Terminal, 2P 4qmm	17		
41	9191351	Endkap, 2P terminal	1		
45	9191197	Fuse 10A, ceramic 32x6,3	2		
50		Cover, lamp	2		
51		Mounting plate, lamp	2		
52		Reinforcement plate	2		
53	9312017	Seal light (for lamp 500W)	2		
54	9312020	Glass, oven illumination	2		
55		Cover profile, oven illumination	2		
58	9293096	Silicon hose Ø12xø3, L=38	1		
59	9293095	Silicon hose Ø10xø4, L=38	1		
60	9110072	Clamp	2		
61	9294069	Bracket, sensors	1		

TDRAC, DOORS

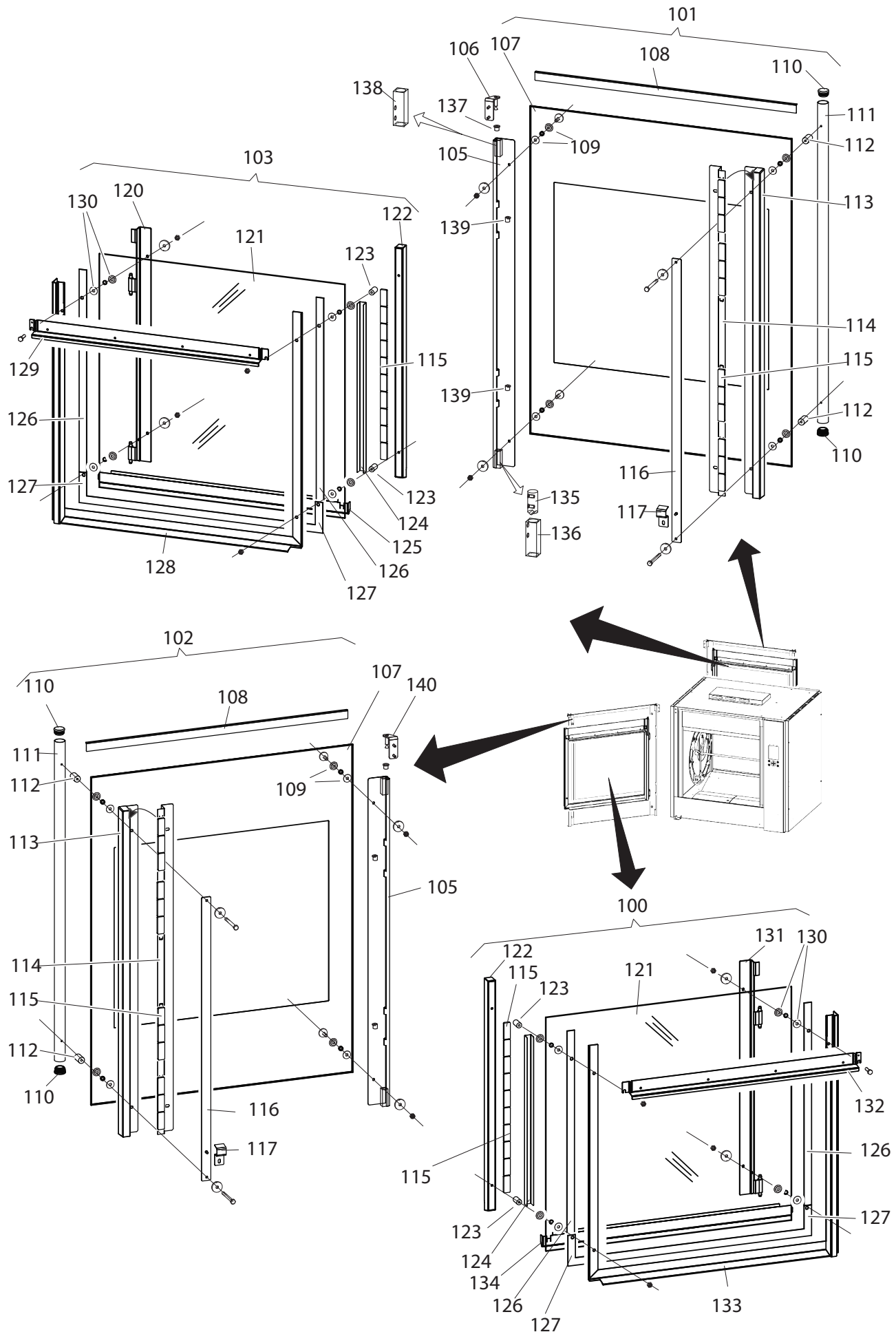

TDRAC, PARTSLIST DOORS

Pos	Part number	Description	Qty	Unit	Priority
100		Ass. Outer door operator side			
101		Ass. Outer door customer side			
102		Ass. Inner door operator side			
103		Ass. Inner door customer side			
105		Hinge Outer door	2		
106		hinge, top right	1		
107		Glass, outer door	2		
108		Protection profile glass top	2		
109	3702342	Collar bush 10x5x3,5	8		
110	2103209	Plug Ø 30mm	4		
111		Door handle	2		
112	9293010	Spacer, door handle	4		
113		Magnet holder	2		
114		Spacer, magnet holder	2		
115	9070141	Magnet, 50x19x6	44		
116		Mounting strip, support bracket	2		
117		Support bracket	2		
120		Hinge, inner door	1		
121	9292013	Glass, inner door	2		
122		Magnet holder	2		
123	9172291	Spacer, Ø15xø5,2x27	4		
124	9294039	Spacer, magnet holder	2		
125		Cover bottom	1		
126	9312022	Seal strip, inner door side	4		
127	9312021	Seal, inner door bottom	2		
128		Ass. Frame inner door, customer side	1		
129		Cover, inner door	1		
130	3702341	Collar bush 10x5x2,5	16		
131		Hinge, inner door, operator side	1		
132		Cover, inner door, operator side	1		
133		Ass. Frame inner door, operator side	1		
134		Cover bottom inner door o.s.	1		
135	9312014	Positioning pin, door hinge	2		
136	9312015	Bearing bush, lower hinge	2		
137	9172054	Collar bearing, bronze	2		
138	9312016	Bearing block, upper hinge	2		
139	9172122	Collar bearing, modified, bronze	4		
140		hinge, top left	1		

Pos

8xx-9xx

See fasteners

TDRAC, ROTOR

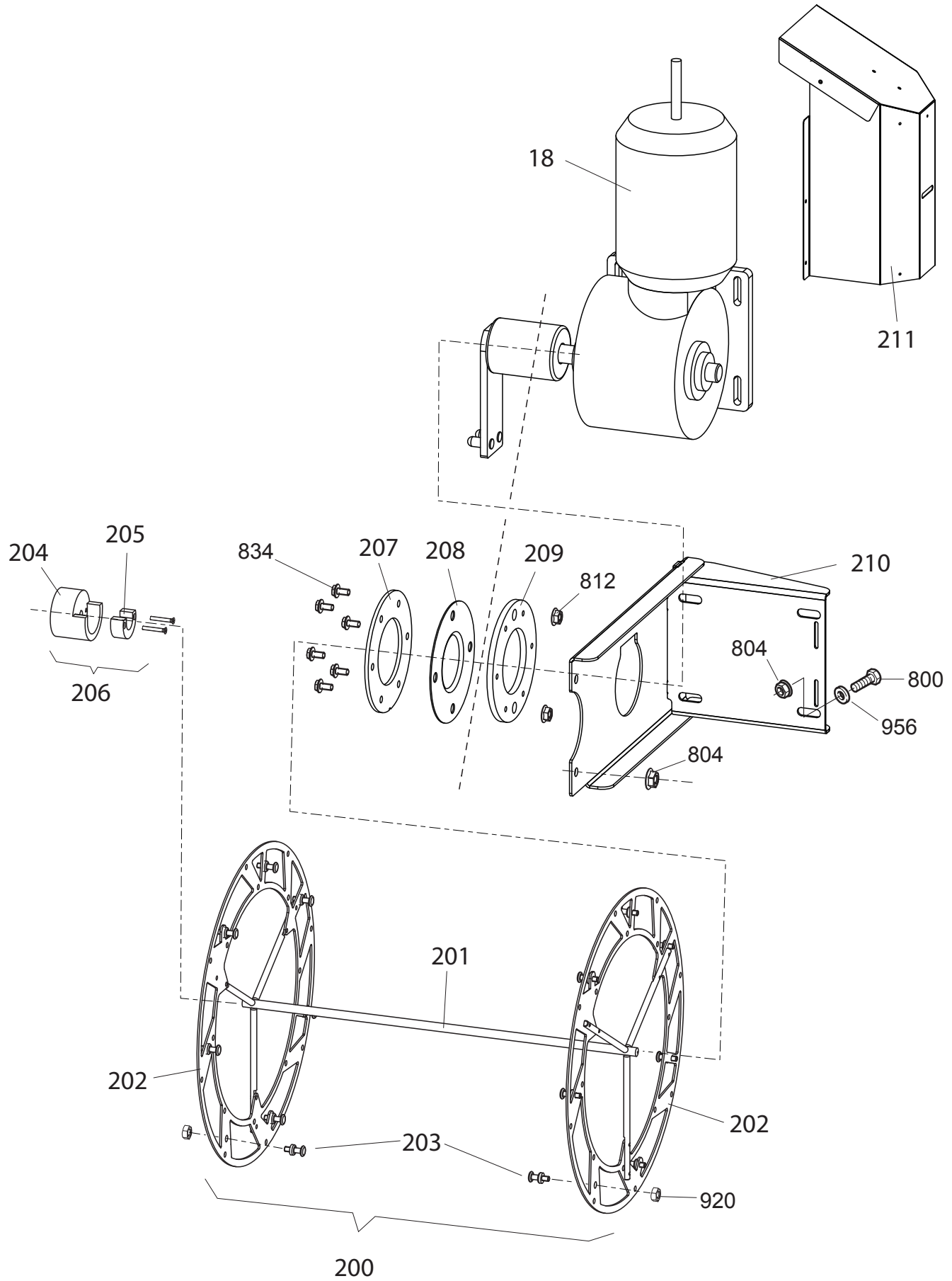

TDRAC, BLOWER & HEATING

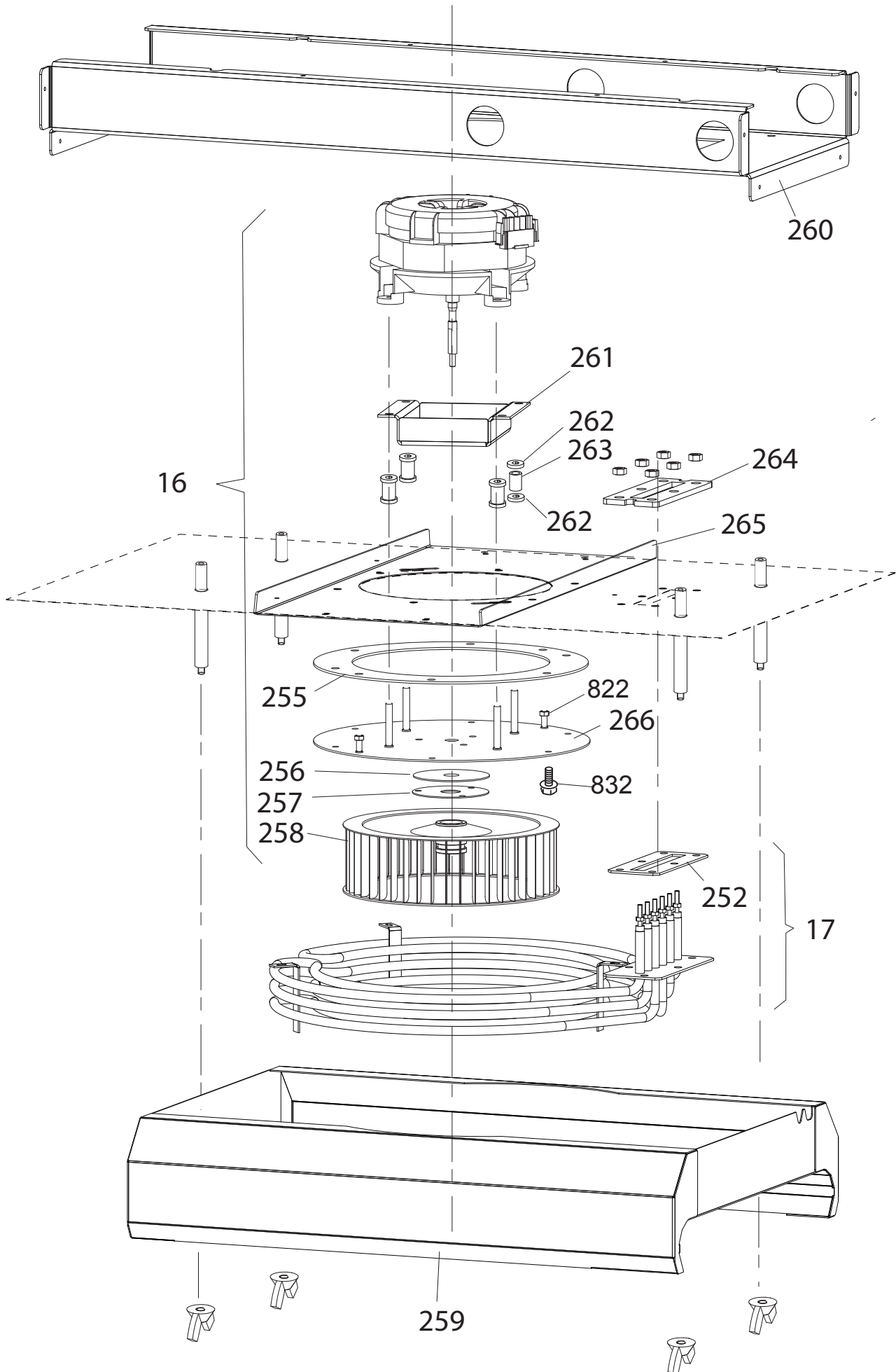

TDRAC, CLEANING SYSTEM

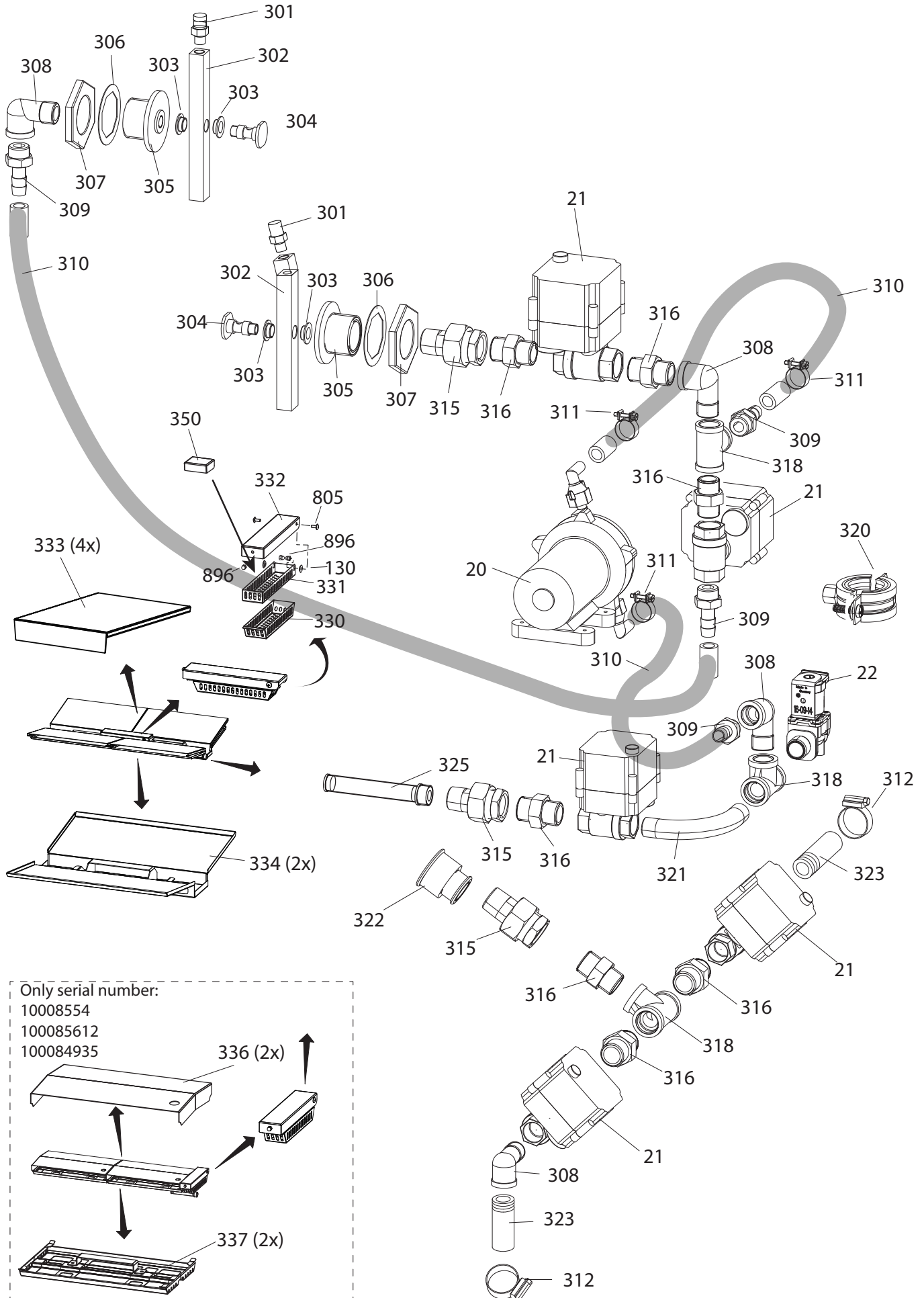

Only serial number:

- 10008554
- 100085612
- 100084935

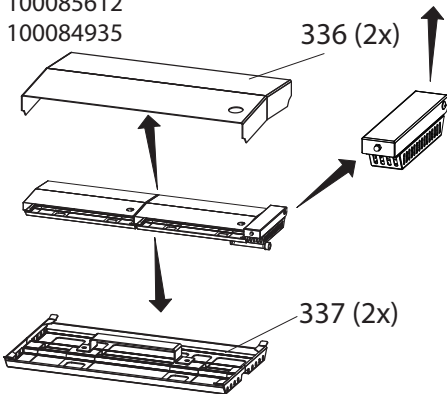

TDRAC, PARTSLIST CLEANING SYSTEM

Pos	Part number	Description	Qty	Unit	Priority
301	9301007	Nozzle, spoon shape	2		
302	9312013	Spray arm	2		
303	9311014	Collar bearing	4		
304	9312012	Shaft , spray arm	2		
305	9312011	Adapter, spray arm	2		
306	9312019	Seal, sprinkler	2		
307	9194457	Nut, 3/4"	2		
308	3721050	Elbow threaded 1/2" (F-M) BSP TP316 150LBS	4		
309	9311011	Hose Pillar 1/2" (M) SS	4		
310	9311012	Hose silibar 13x20 mm			
311	9311018	Hose clamp, 19-21	6		
312	6000032	Hose clamp, 26-38	2		
315	9311009	Union conicle 1/2" (M-F) SS	3		
316	3721047	Hexagon nipple threaded 1/2" (M-M) BSP TP316 150LBS	7		
318	3721046	Tee threaded 1/2" (F-F-F) BSP TP316 150LBS	3		
320	2650194	Clamp, suspension	1		
321	9311010	Bend 90° threaded 1/2" (M-M) SS	1		
322	9191228	Socket adapter, 3/4"x 1/2"	1		
323	9311019	Welding nipple, 1/2"	2		
325	9310401	Suction filter	1		
330		Lower tablet tray	1		
331		Upper tablet tray	1		
332		Cover, tray	1		
333		Grease cover (mark II)	4		
334		Screen (markII)	2		
336		Grease cover (mark I)	2		
337		Screen (mark I)	2		
350	9312040	Cleaning Tabs,box 190 pcs	1		

TDRAC, SHEET METAL

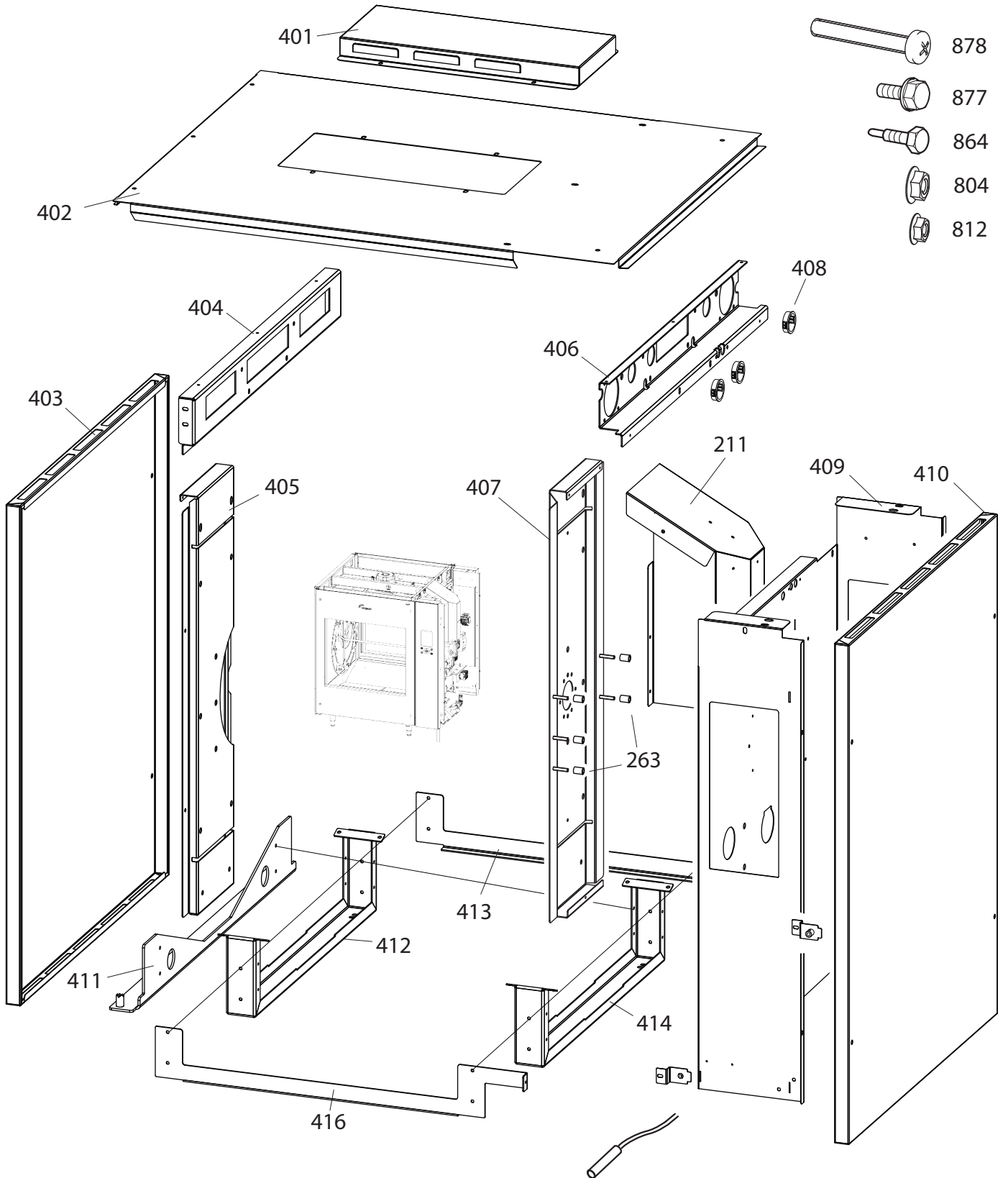

TDRAC, UNDERFRAME

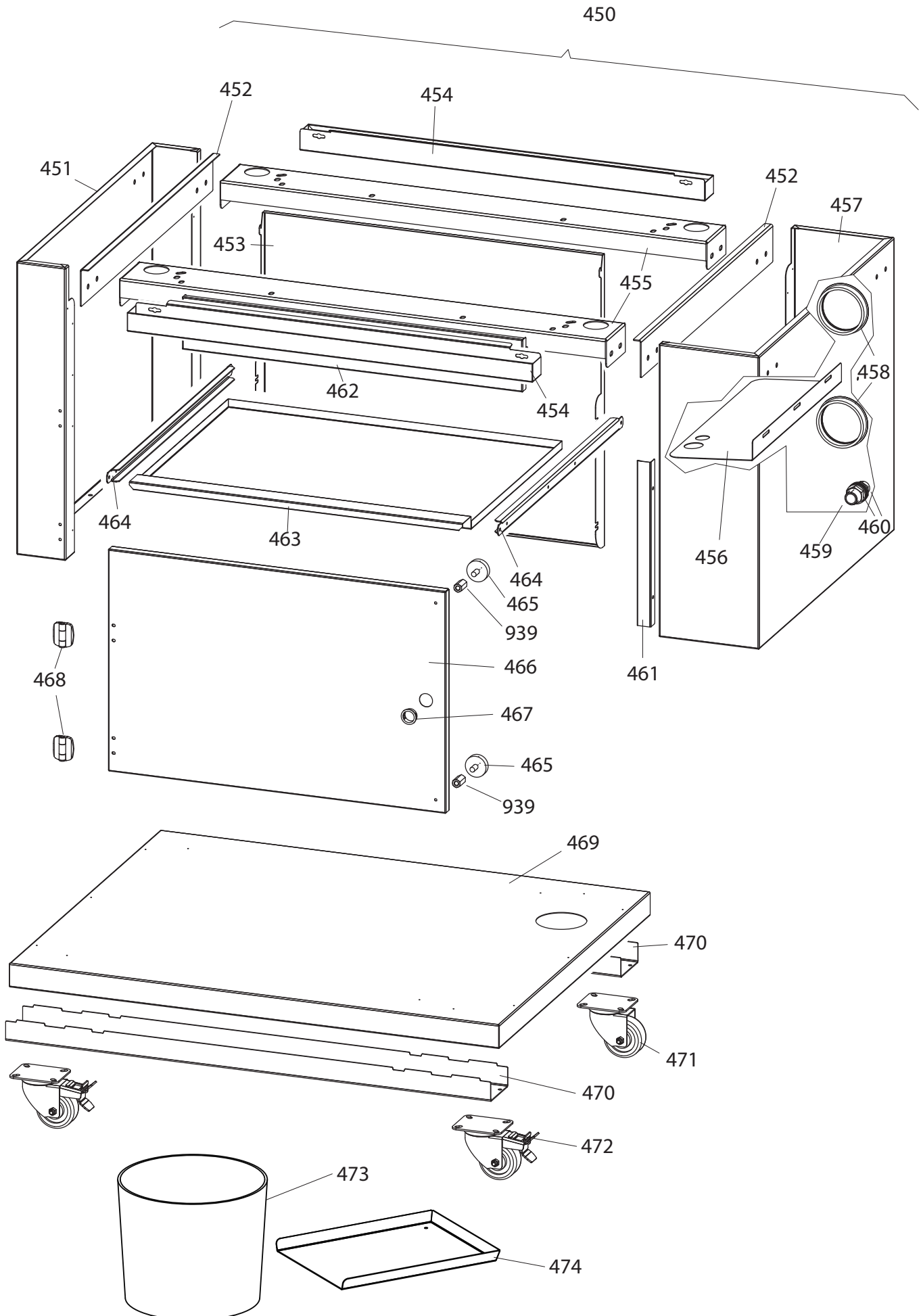

TDRAC, PARTSLIST UNDERFRAME

Pos	Part number	Description	Qty	Unit	Priority
450		ass. Underframe			
451		Side panel, left, underframe	1		
452		Bracket, underframe	2		
453		Back panel, underframe	1		
454		Gutter, drip water	2		
455		Construction profile	1		
456		Support, drain	1		
457		Side panel, right, underframe	1		
458	9171141	Grommet, 88,4mm	1		
459	9303028	Nipple, 3/4" BSP (30mm), SS	1		
460	9194457	Nut, 3/4	1		
461		Magnetic strip	1		
462		Front panel, underframe	1		
463		sliding tray	1		
464		Tray support	2		
465	9084077	Magnet, Ø22mm	2		
466		Door	1		
467	9070840	Grommet	1		
468	9191106	Hinge	2		
469		Bottom plate, underframe	1		
470		Construction profile	2		
471	9172065	Swivel castor	2		
472	9172066	Swivel castor with brake	2		
473	9191099	Bucket, plastic 11,3 ltr	1		
474		Support, bucket			

CIRCUIT DIAGRAM TDRAC (MARK III)

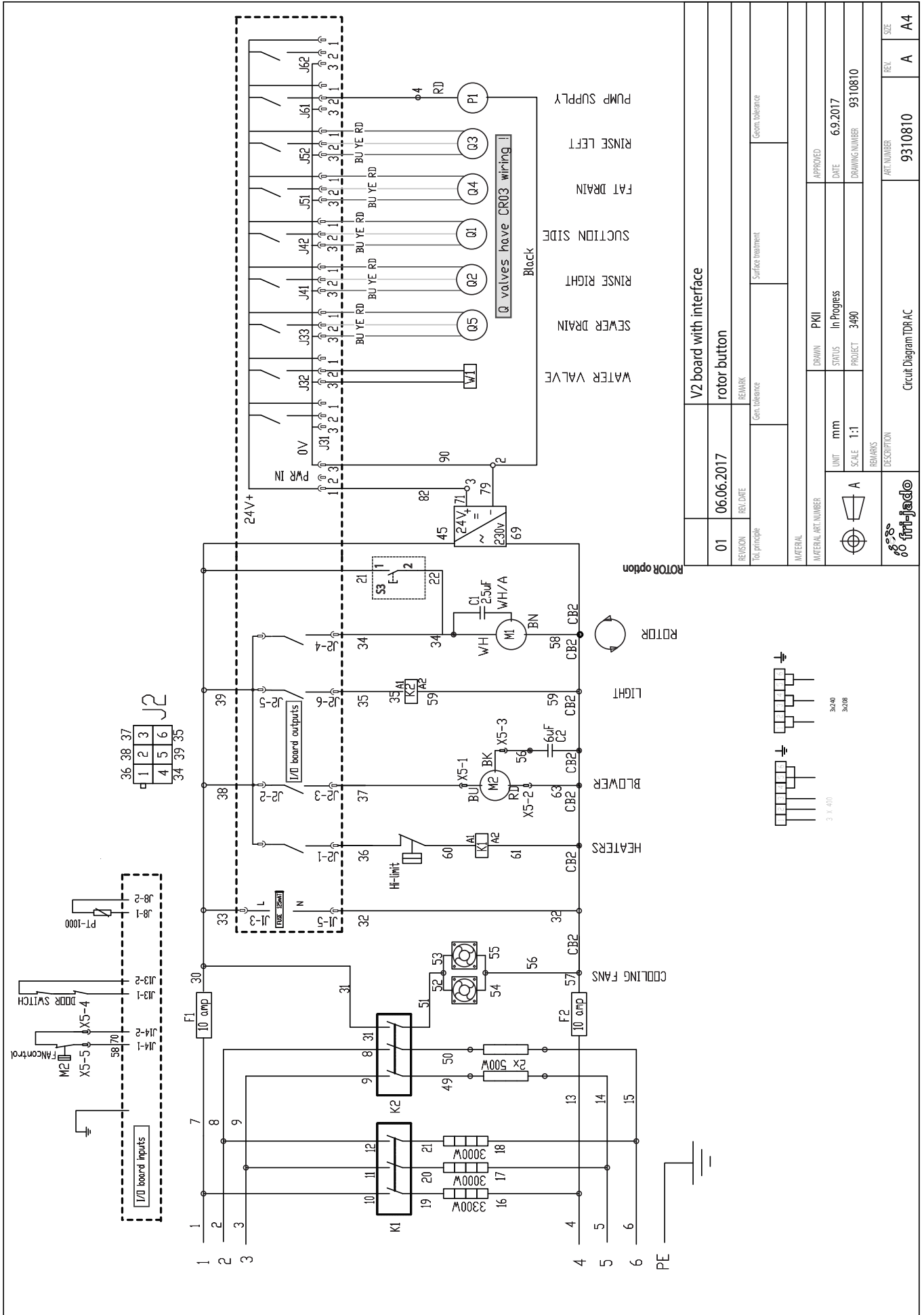

01	06.06.2017	REVISION	REQ. DATE	06.06.2017	rotor button	REMARK
Tol. principle			Geom. tolerance			Surface treatment
MATERIAL						
MATERIAL ART. NUMBER		DRAWING		PK11		APPROVED
UNIT		STATUS		In Progress		DATE
SCALE		PROJECT		3490		DRAWING NUMBER
3 x 40		3x240		3x208		9310810
3 x 40		3x240		3x208		9310810
REMARKS						
DESCRIPTION			Circuit Diagram TDR-AC		ART. NUMBER	9310810
REV.			A		REV.	A
SIZE			A4		SIZE	A4

WIRING DIAGRAM TDRAC (MARK III)

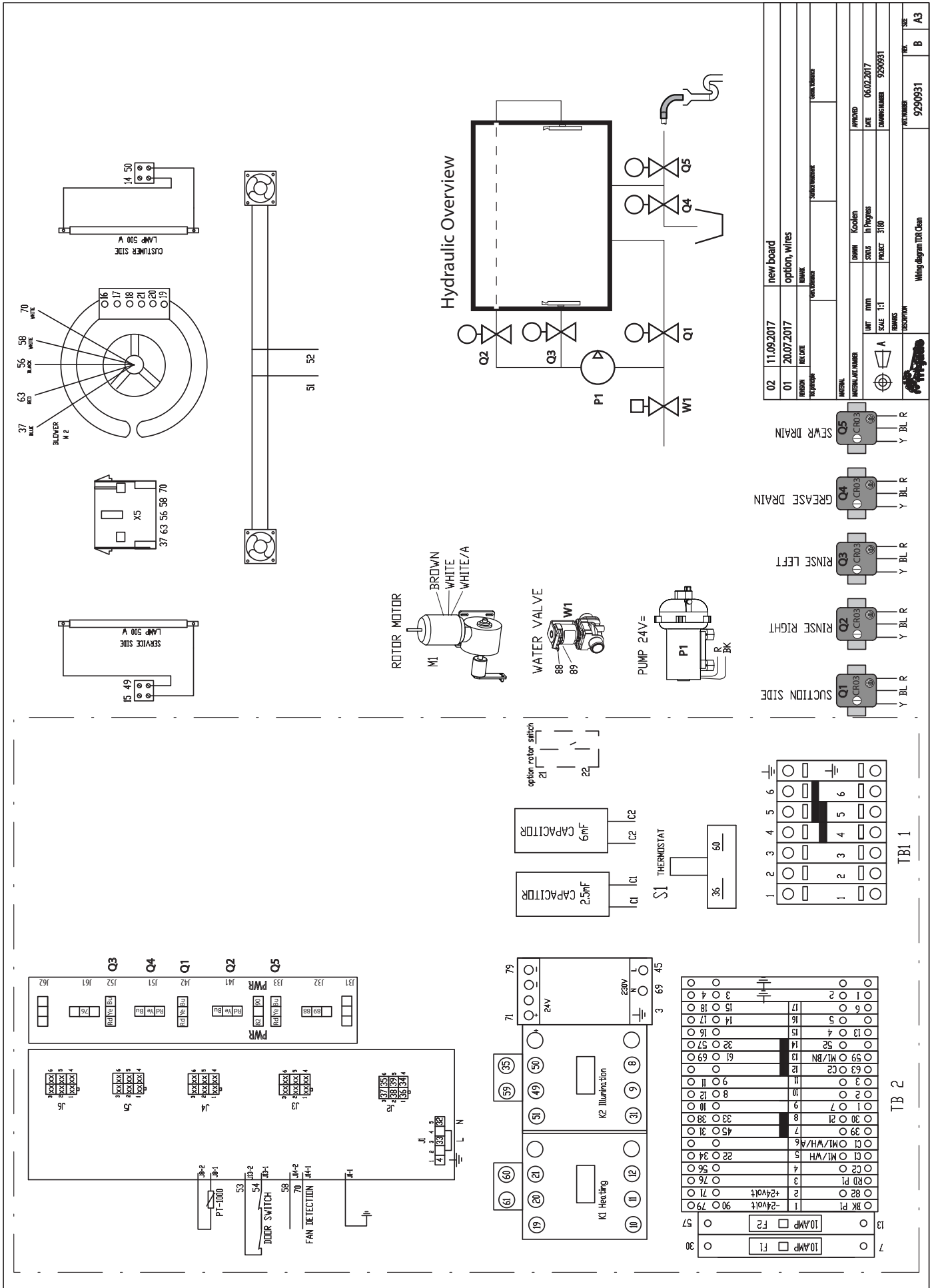

REVISION	DATE	BY	DESCRIPTION
01	20.07.2017		option, wires
02	11.09.2017		new board

APPROVED	DATE	PROJECT
Koolen	06.02.2017	3180

REVISION	DATE	BY	DESCRIPTION
01	20.07.2017		option, wires
02	11.09.2017		new board

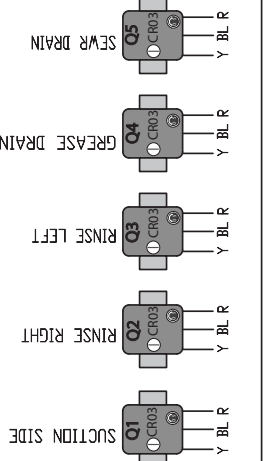

CIRCUIT DIAGRAM TDRAC (MARK II)

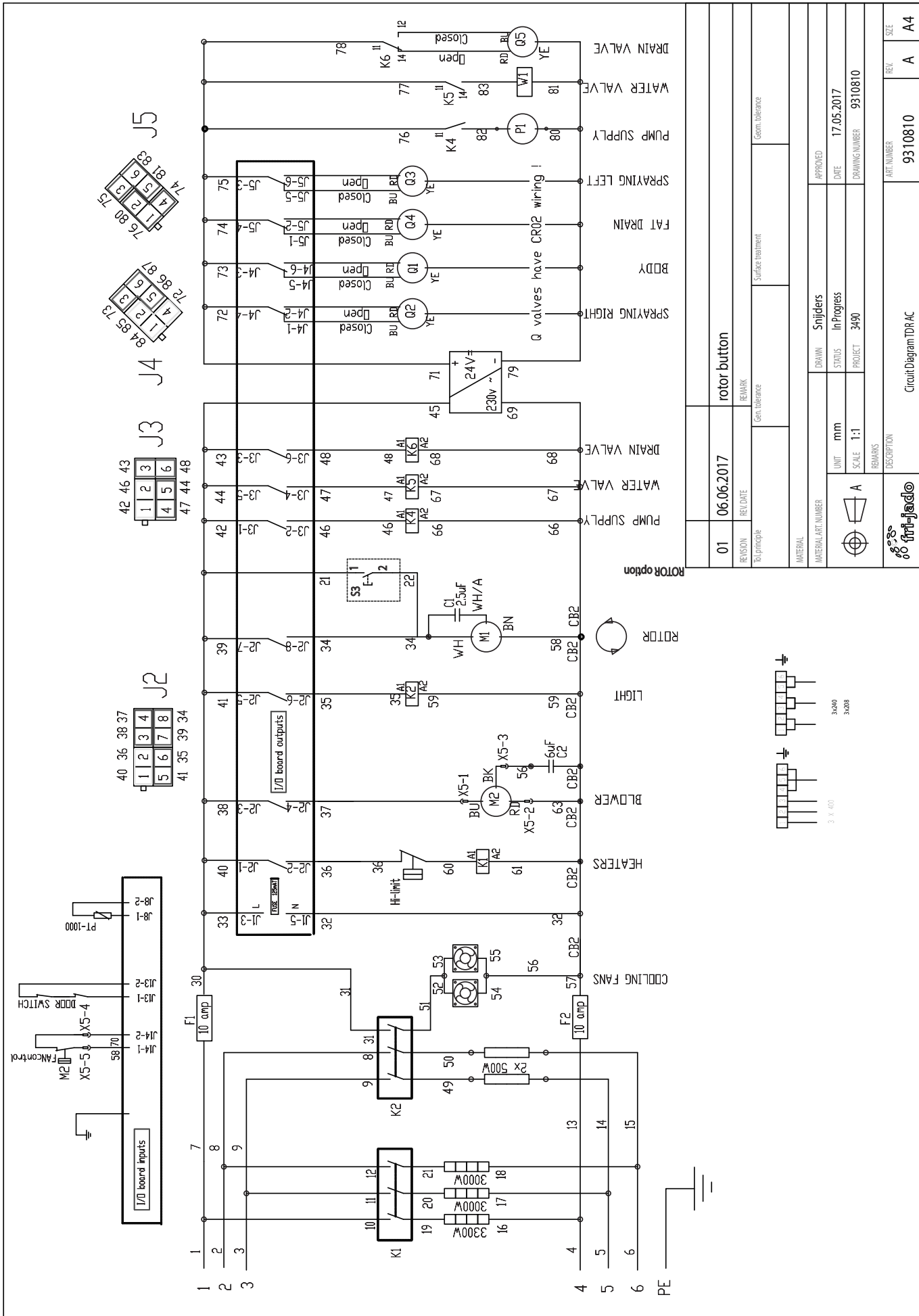

CIRCUIT DIAGRAM TDRAC (MARK 1)

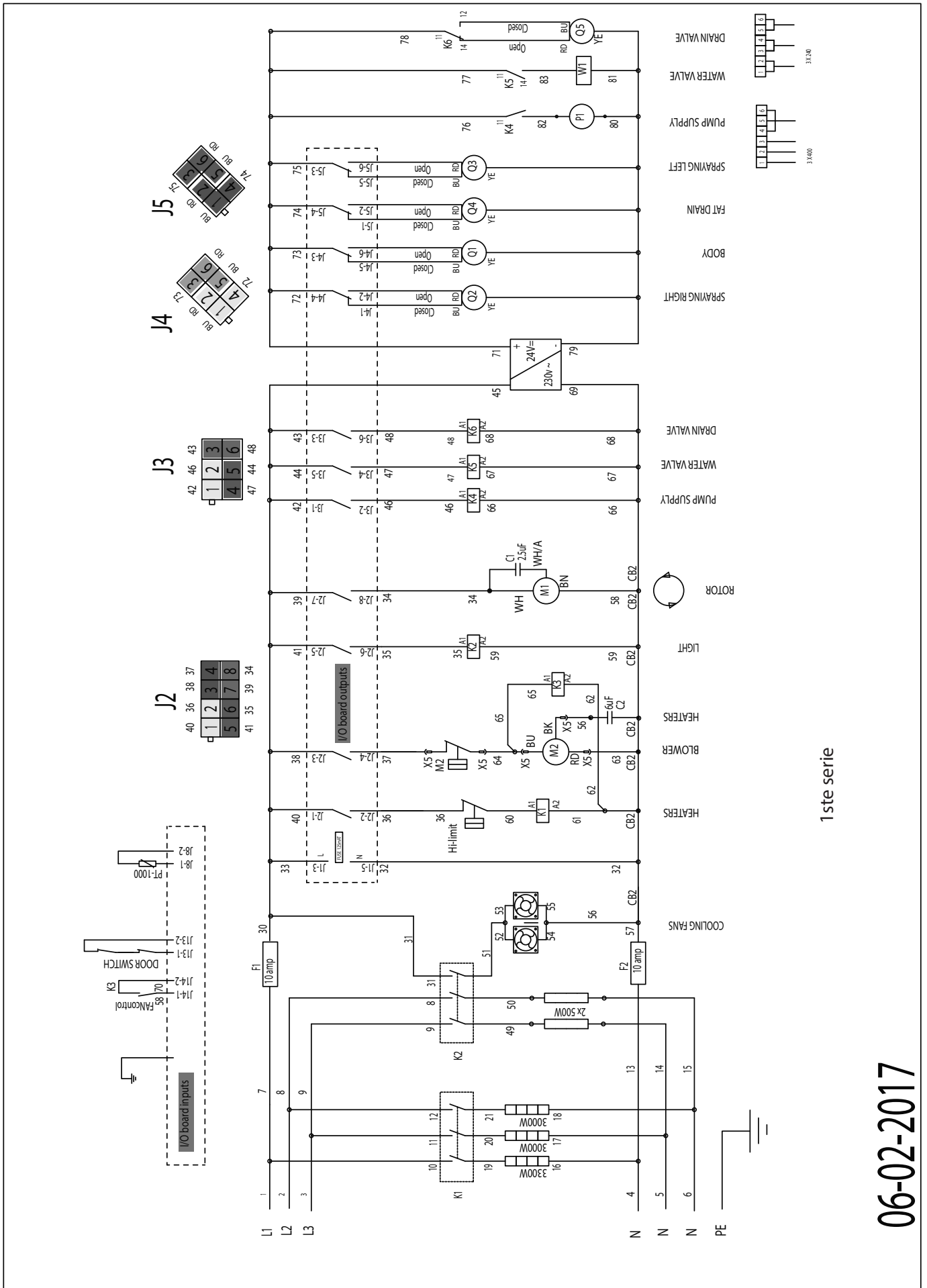

06-02-2017

WIRING DIAGRAM TDRAC (MARK 1)

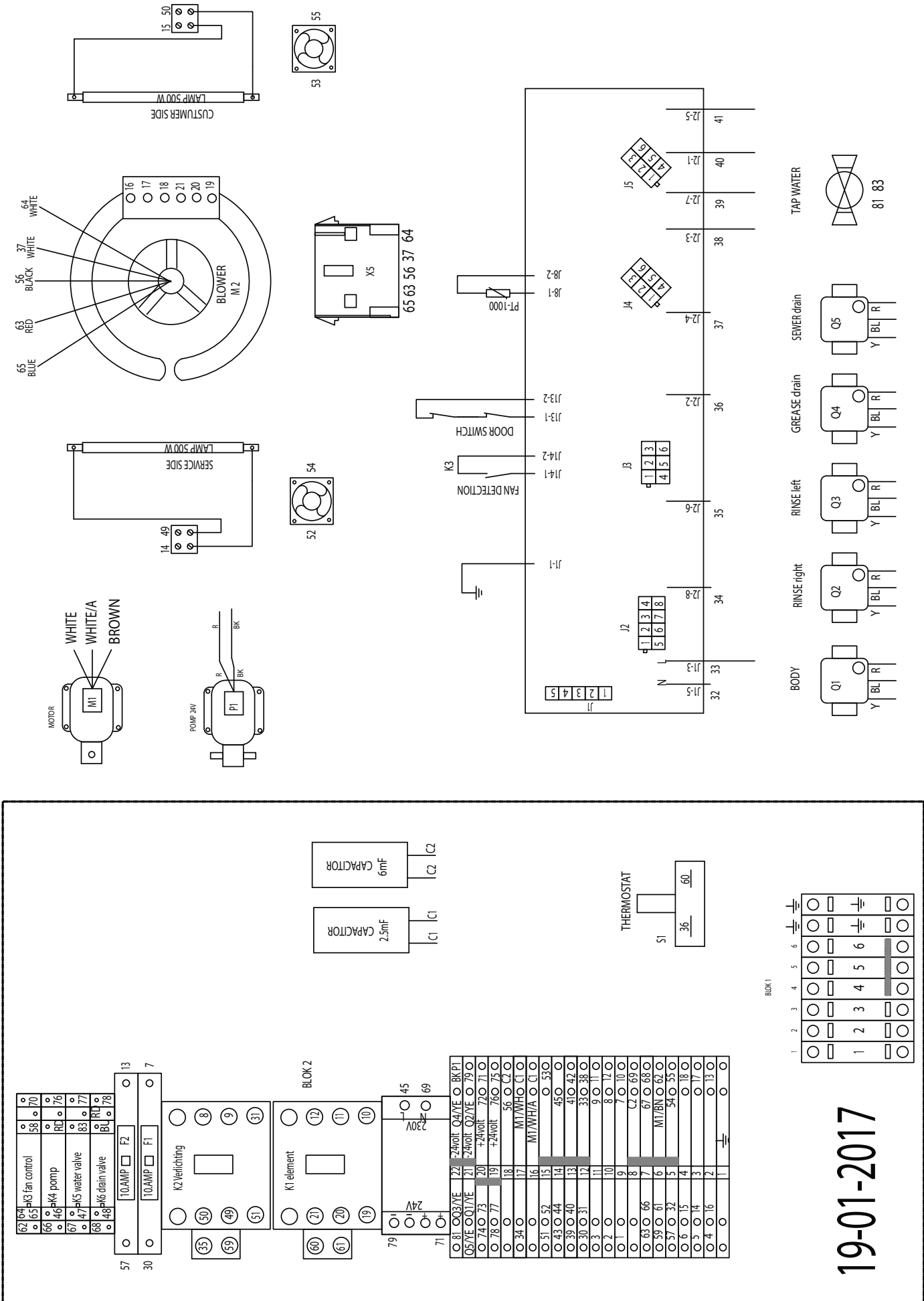

19-01-2017

