

# USER MANUAL

TDR5-M

TDR7-M

TDR8-M



## WARNING

Read the instructions before using the machine.

**KEEP THIS USER MANUAL FOR FUTURE USE**

© 2015 Fri-Jado BV, Etten-Leur, The Netherlands.

We advise you to contact your supplier for the guarantee period and conditions. Further we refer to our General Terms and Conditions for Sales and Delivery that are available upon request.

The manufacturer does not accept any liability for damage or injury caused by failing to adhere to these regulations or by not observing the usual caution or care in actions, operation, maintenance or repair activities, even if not explicitly described in this manual.

As a result of constant commitment to improvement, it may happen that your unit deviates in detail from what is described in this manual. For this reason, the given instructions are only a guideline for the installation, use, maintenance and repair of the unit referred to in this manual. This manual has been composed with the utmost care. The manufacturer shall, however, not be held responsible for any mistakes in this manual nor for any consequences thereof. The user is allowed to copy this manual for own use. Further all rights are reserved and nothing in this manual may be reproduced and/or made public in any way.

**Modifications:**

In case of unauthorized modifications in or on the unit, every liability on the part of the manufacturer becomes null and void.

Empty page.

# CONTENTS

|           |  |           |
|-----------|--|-----------|
| <b>1.</b> | <b>INTRODUCTION .....</b>                                    | <b>6</b>  |
| 1.1       | General.....   | 6         |
| 1.2       | Identification of the unit.....                              | 6         |
| 1.3       | Pictograms and symbols.....                                  | 6         |
| 1.4       | Safety instructions .....                                    | 7         |
| 1.4.1     | General.....   | 7         |
| 1.4.2     | Moving.....  | 8         |
| 1.4.3     | Outdoor use restrictions.....                                | 8         |
| 1.5       | Hygiene .....  | 9         |
| 1.6       | Service and technical support.....                           | 9         |
| 1.7       | Storage.....   | 9         |
| 1.8       | Disposal.....  | 9         |
| <b>2.</b> | <b>DESCRIPTION OF THE UNIT .....</b>                         | <b>10</b> |
| 2.1       | Technical description .....                                  | 10        |
| 2.2       | Intended use.....  | 10        |
| 2.3       | Accessories .....  | 10        |
| <b>3.</b> | <b>INSTALLATION AND FIRST USE .....</b>                      | <b>11</b> |
| 3.1       | Unpacking the unit .....                                     | 11        |
| 3.2       | Dismantling the pallet.....                                  | 12        |
| 3.3       | Installation and positioning.....                            | 12        |
| 3.4       | First use.....   | 13        |
| 3.4.1     | Metal odour .....  | 14        |
| <b>4.</b> | <b>OPERATION AND USE .....</b>                               | <b>15</b> |
| 4.1       | Control Panel.....   | 15        |
| 4.2       | Switching-on the unit.....                                   | 16        |
| 4.3       | Loading the unit .....                                       | 16        |
| 4.3.1     | Loading the rotisserie using meat forks.....                 | 16        |
| 4.3.2     | Loading the rotisserie using V-shape spits (accessory) ..... | 18        |
| 4.3.3     | Loading the rotisserie using meat baskets (accessory).....   | 18        |
| 4.3.4     | Loading the rotisserie using chicken racks (accessory) ..... | 19        |
| 4.3.5     | Loading the rotisserie using two different accessories. .... | 20        |
| 4.4       | Grilling .....   | 20        |
| 4.4.1     | Grilling temperature .....                                   | 20        |
| 4.4.2     | Grilling time .....  | 20        |
| 4.5       | Taking out the products .....                                | 20        |
| 4.5.1     | Taking out the meat forks .....                              | 21        |
| 4.5.2     | Taking out the V-shape spit (accessory) .....                | 21        |
| 4.5.3     | Taking out the chicken racks (accessory). ....               | 21        |
| 4.5.4     | Taking out the meat basket (accessory) .....                 | 21        |
| 4.6       | Emptying grease drawer .....                                 | 22        |

---

|           |   |           |
|-----------|---|-----------|
| 4.7       | Switching-off the unit.....                             | 22        |
| <b>5.</b> | <b>CLEANING AND MAINTENANCE .....</b>                   | <b>23</b> |
| 5.1       | Maintenance schedule .....                              | 23        |
| 5.2       | Daily Cleaning.....                                     | 23        |
| 5.3       | Weekly Cleaning.....                                    | 24        |
| 5.4       | Monthly Cleaning .....                                  | 25        |
| 5.5       | Cleaning guidelines for non-stick coated surfaces ..... | 26        |
| <b>6.</b> | <b>MALFUNCTIONS AND SERVICE.....</b>                    | <b>27</b> |
| 6.1       | Replace the mains cord .....                            | 27        |
| 6.2       | Replace a lamp.....                                     | 28        |
| <b>7.</b> | <b>TECHNICAL SPECIFICATIONS .....</b>                   | <b>29</b> |
| <b>8.</b> | <b>ACCESSORIES.....</b>                                 | <b>30</b> |

## 1. INTRODUCTION

### 1.1 General

This manual is intended for the user of the TDR (Turbo Deli Rotisserie). The features and controls are being described, along with directions for the safest and most efficient use, in order to guarantee a long life of the unit.

All pictograms, symbols and drawings in this manual apply to all TDR-M models.

### 1.2 Identification of the unit

The identification plate can be found on the outside of the machine, and contains the following data:

- Name of the supplier or the manufacturer
- Model
- Serial number
- Year of construction
- Voltage
- Frequency
- Power consumption

### 1.3 Pictograms and symbols

In this manual, the following pictograms and symbols are used:

**WARNING**

Possible physical injury or serious damage to the unit, if the instructions are not carefully followed.

**WARNING**

Hazardous electrical voltage.

**WARNING**

Danger of getting injured by hot surfaces.



Suggestions and recommendations to simplify indicated actions.



Recycling symbol.



Direction of view symbol.

## 1.4 Safety instructions

**WARNING**

The outside of the unit can be very hot.

**WARNING**

The maximum load on top of the unit may never exceed 50 kg (110 lbs).

**WARNING**

Risk of slippery floor: Spills may cause slippery surfaces, clean-up promptly

**WARNING**

Always use the brakes on both front wheels:

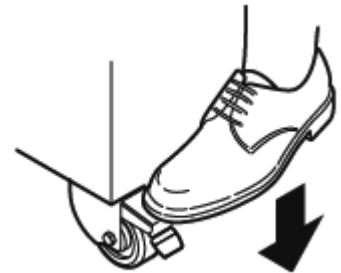

### 1.4.1 General

The user of the unit will be fully responsible for abiding the locally prevailing safety- rules and regulations.

The unit may be operated by qualified and authorized persons only. Anyone working on or with this unit must be familiar with the contents of this manual and carefully follow all guidelines and instructions. Never change the order of the steps to be performed. The management must instruct the personnel on the basis of this manual and follow all instructions and regulations.

The pictograms, labels, instructions and warning signs attached to the unit, are part of the safety measures. They may never be covered or removed, and have to be clearly visible during the entire lifetime of the unit.

Immediately repair or replace damaged or illegible pictograms, warnings and instructions.

- To avoid short-circuiting, never clean the unit using a water hose. For cleaning instructions, see section 5.
- During the grilling process, the unit can get very hot.
- When the door is opened the rotor stops and the heater is de-energized.
- The unit must be cleaned regularly to ensure proper functioning and prevent fire hazard (over heating). Especially the back of the fan plate.
- The fat collecting drawer must be emptied regularly, to prevent overflow.
- This appliance can be used by children aged from 8 years and above and persons with reduced physical, sensory or mental capabilities or lack of experience and knowledge if they have been given supervision or instruction concerning use of the appliance in a safe way and understand the hazards involved.
- Children shall not play with the appliance.
- Cleaning and user maintenance shall not be made by children without supervision.

### 1.4.2 Moving

When moving the unit:

- Before moving the unit, first switch off the mains voltage by pulling the plug from the wall socket and empty the fat collecting drawer. After that, cool-down the unit for at least ten minutes.
- The units equipped with wheels are not suited to pass ledges or obstacles higher than 10 mm (0.4 inch).
- When moving the unit, always push at the centre of the unit. Never on top. Never at the bottom.
- Make sure that the wheels can move freely, so they never touch the power lead.

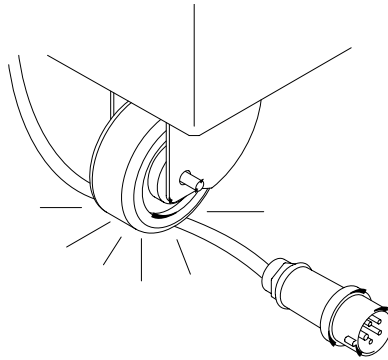

### 1.4.3 Outdoor use restrictions

To avoid short-circuiting, the units may not be used outdoors unprotected. Placing under a screen is allowed.





## 1.5 Hygiene

The quality of a fresh product always depends on hygiene. Especially grilling products. With the risk of salmonella contamination – especially for chicken products – you must make sure that grilled products can never be mixed with uncooked products. Also contact between grilled products and hands or tools that have been in contact with raw chicken meat, must be avoided at all times. Hands or tools that have been in contact with raw chicken meat, must be cleaned thoroughly.

## 1.6 Service and technical support

The electrical schematics of your unit is included. In case of malfunctions you can contact your dealer/service agent. Make sure you have the following data available:

- Model.
- Serial number.

This data can be found on the identification plate.

## 1.7 Storage

If the unit will not be used temporarily, and will be stored, follow these instructions:

- Clean the unit thoroughly.
- Wrap the unit from getting dusty.
- Store the unit in a dry, non-condensing environment.

## 1.8 Disposal



Dispose of the machine, any components or lubricants removed from it safely in accordance with all local and national safety and environment requirements.

## **2. DESCRIPTION OF THE UNIT**

### **2.1 Technical description**

The unit uses a combination of direct infra-red radiation and convection heat.

The rotor is being wheeled by a maintenance-free motor with a gear box.

The fan provides an equally divided heat. The glass panes are equipped with a heat reflecting layer to keep the heat inside the grill.

The plating of the unit is made of stainless steel. The product contact parts are made of stainless steel AISI 304 (eventual with PTFE coating).

The mains cable is provided with a plug.

The grilling process can be stopped by using the main switch.

### **2.2 Intended use**

The TDR has been designed for grilling meat products. Any other use will not be regarded as intended use.

The manufacturer accepts no liability whatsoever for loss or injury caused by failing to strictly adhere to the safety guidelines and instructions in this manual or due to carelessness during installation, use, maintenance and repair of the unit referred to in this manual and any of its accessories.

Use the unit in perfect technical condition only.

### **2.3 Accessories**

Your unit contains the following standard accessories:

- Meat forks.
- User manual.

For optional accessories refer to section 8.

### 3. INSTALLATION AND FIRST USE



All packing materials used for this unit are suited for recycling.

After unpacking, check the state of the unit. In case of damage, store the packing material, and contact the transporter within fifteen working days after receiving the goods.

#### 3.1 Unpacking the unit

Your unit is packed in a plastic top cover, protective corners and a carton box around it. All units are placed on a wooden pallet. Around the box there are two tightening straps.

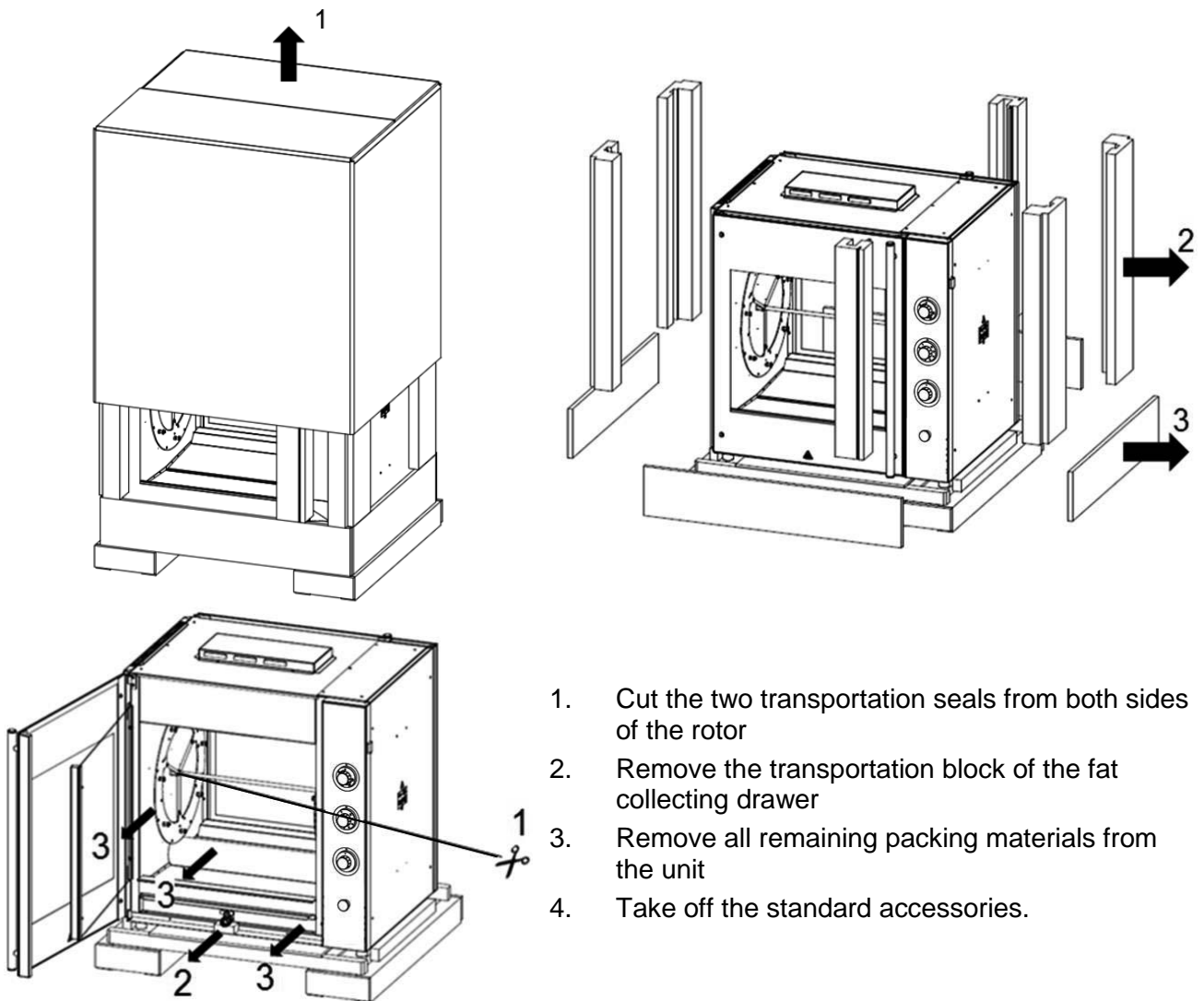

1. Cut the two transportation seals from both sides of the rotor
2. Remove the transportation block of the fat collecting drawer
3. Remove all remaining packing materials from the unit
4. Take off the standard accessories.

### 3.2 Dismantling the pallet

For proper unpacking the unit, the pallet must be taken apart.

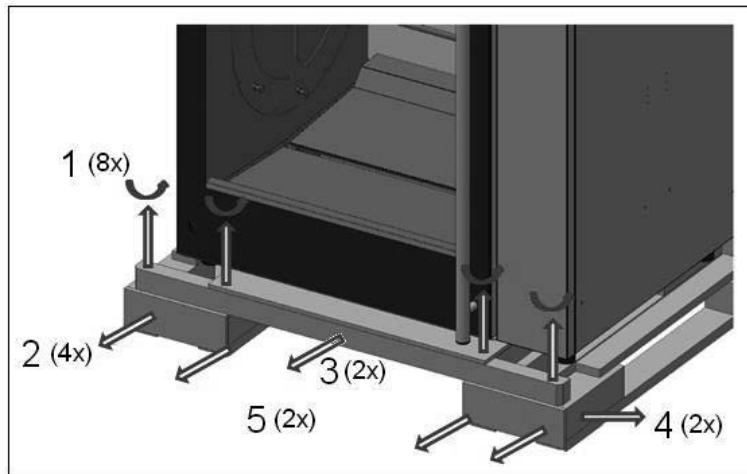

### 3.3 Installation and positioning



#### WARNING

Position the unit on a flat and horizontal surface. A temporarily inclined plane of maximum 5° is allowed.

- The user must have sufficient freedom of movement to properly operate the unit

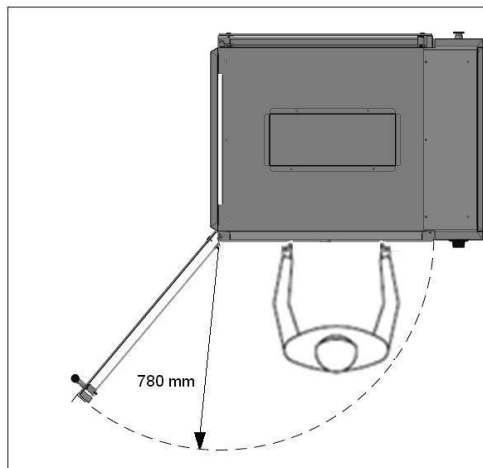

- The minimum free distance must be at least 250 mm (10 inch).
- During grilling, the glass panes will get very hot. While positioning, keep the unit out of children's reach.
- In case of a wheeled unit, the floor must be flat and levelled.
- The unit has a mains plug, and must be connected to a wall socket with the proper mains voltage. The wall socket must be mounted by a certified electrician.

### 3.4 First use

When using the unit for the first time, clean the interior thoroughly with soap suds and heat up the unit, see section 3.4.1. After commissioning discolouration of the cooking/grilling area can occur.

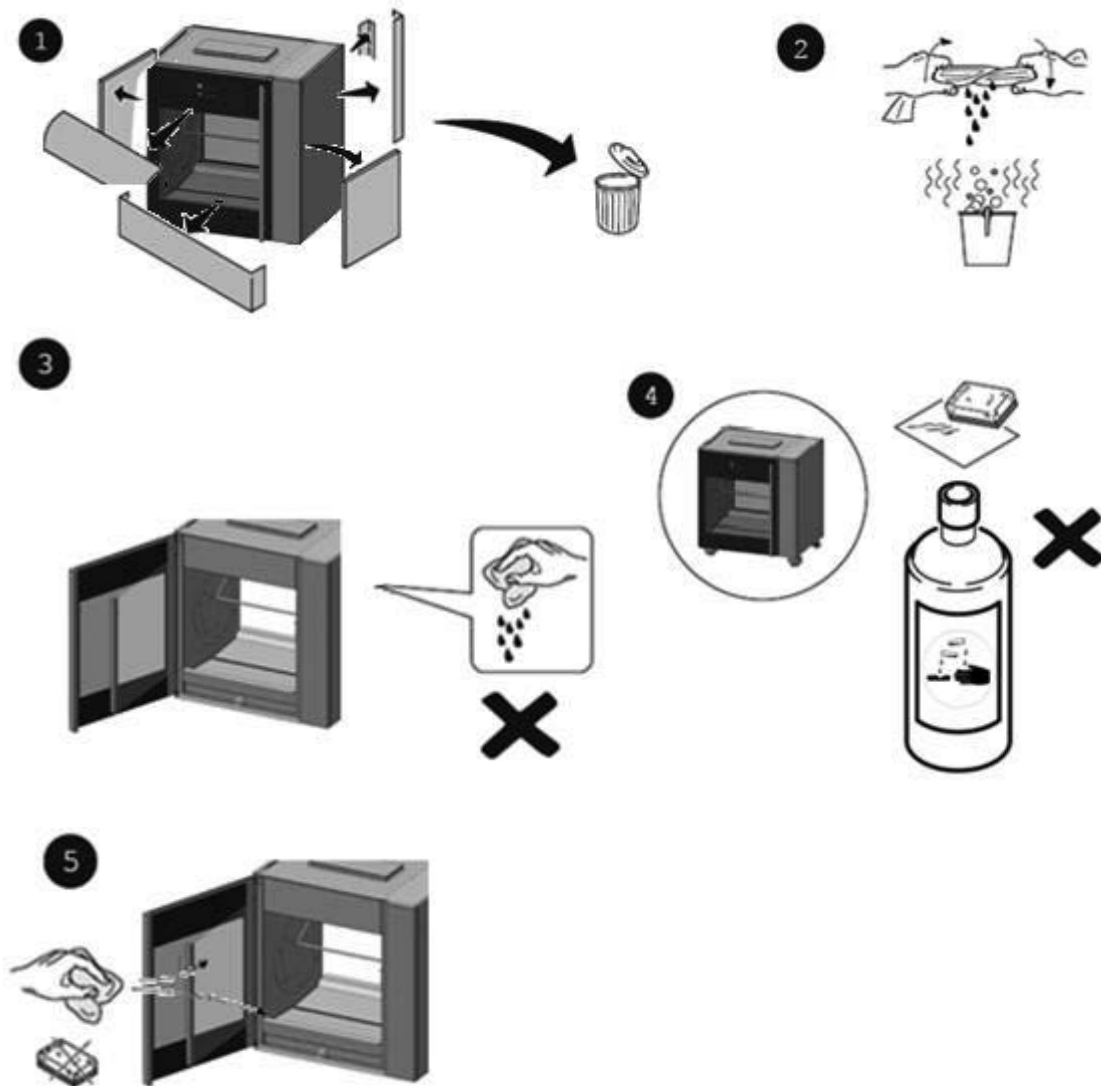

The cleaning remains will find its way to the fat collection drawer, so this drawer must be cleaned and emptied after cleaning the unit.

- Place the bottom plates in the grilling compartment.

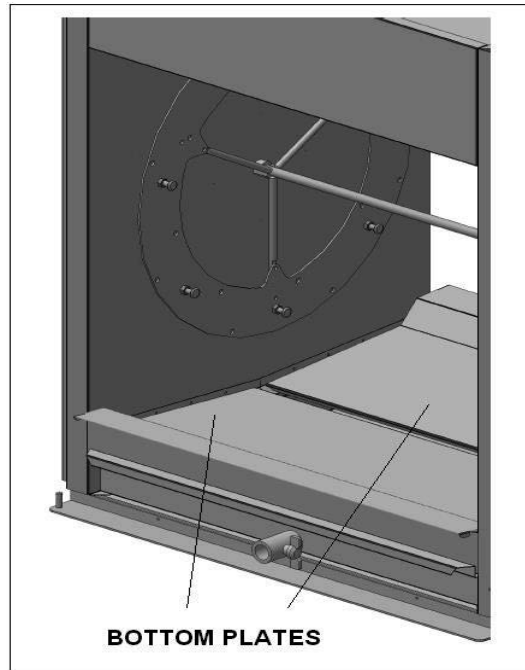

### 3.4.1 Metal odour

To remove the metal odour that will appear at first use, the unit must be heated at the maximum temperature (250°C/482°F) for at least half an hour.

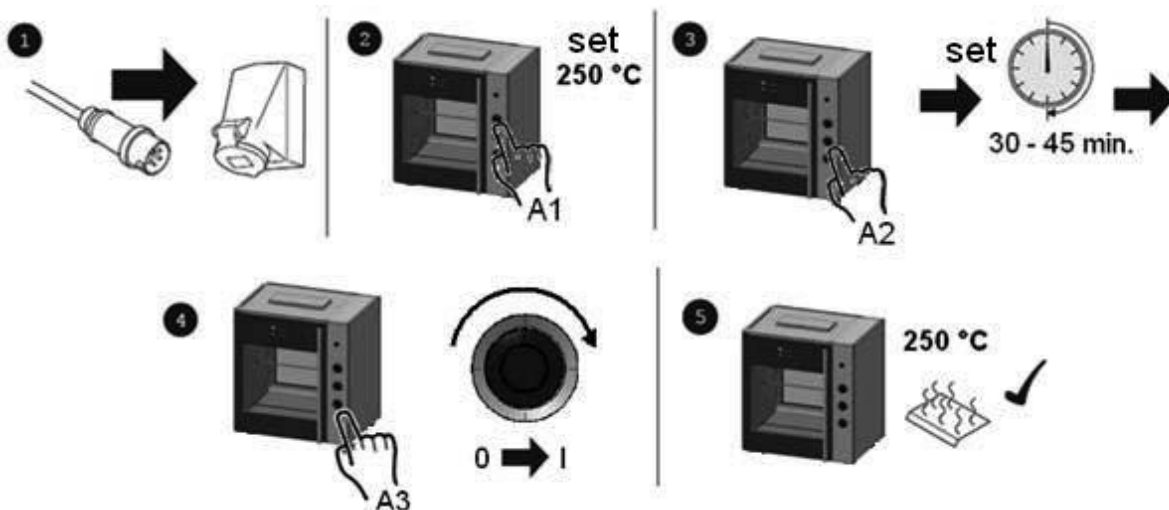

## 4. OPERATION AND USE

### 4.1 Control Panel

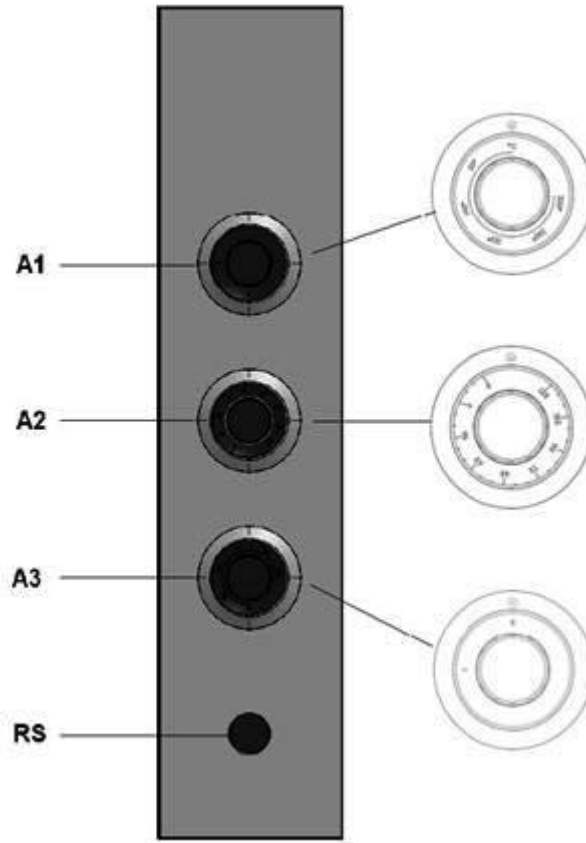

| Button | Function                         |
|--------|----------------------------------|
| A1     | Temperature selector             |
| A2     | Timer selector                   |
| A3     | Mains Switch                     |
| RS     | ROTOR BUTTON to Rotate the rotor |

### 4.2 Switching-on the unit

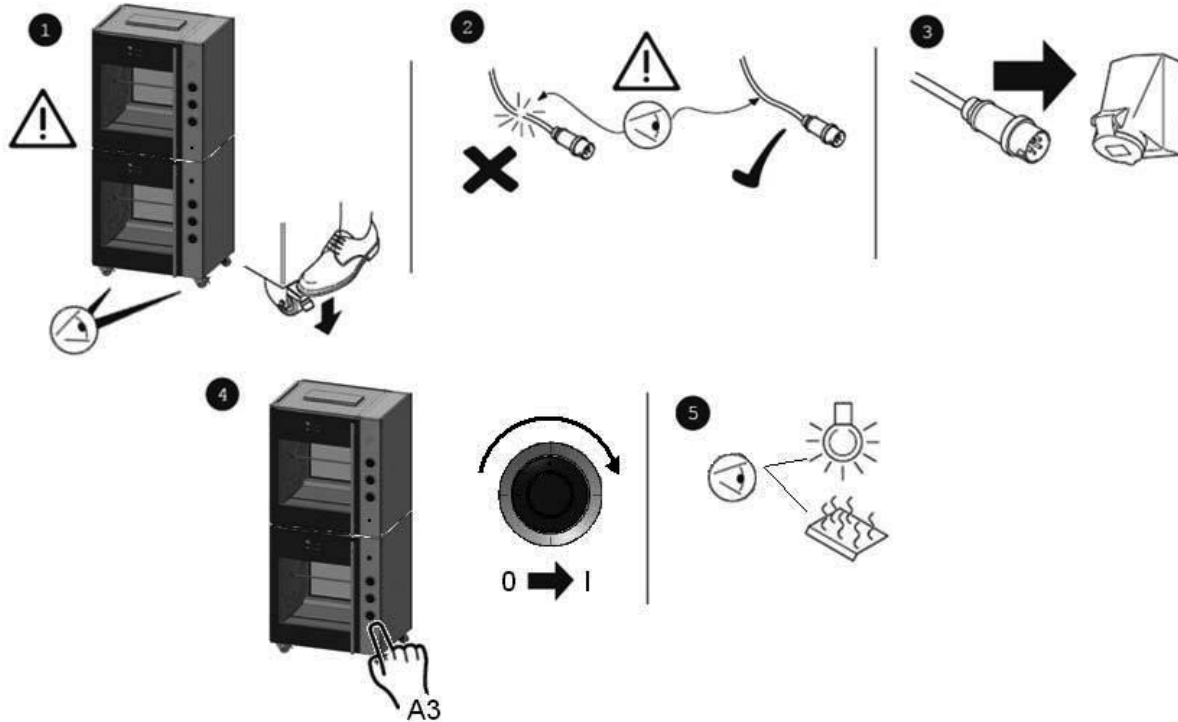

### 4.3 Loading the unit

When the door is open press the rotor button to activate the rotor. This allow easy loading or unloading the products.

Whilst loading the unit, make sure that the rotor gets evenly loaded, so that the mass of the products is evenly spread over de rotor, causing an equal balance. Do not allow empty meat forks, meat baskets and chicken racks etc. in the grilling process.

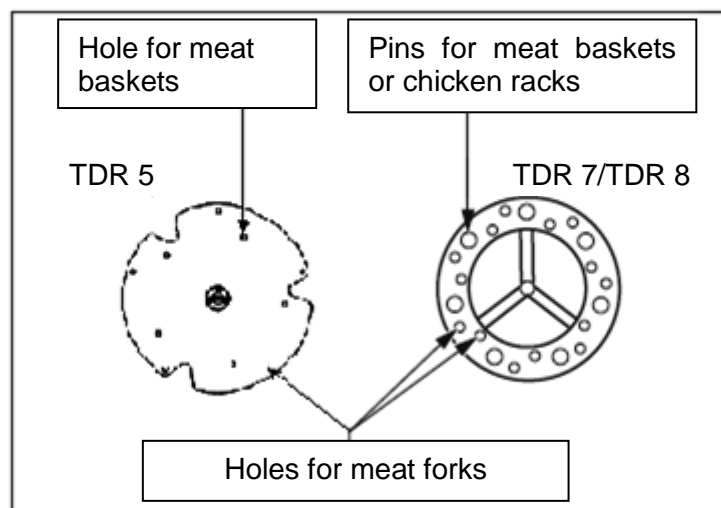

#### 4.3.1 Loading the rotisserie using meat forks

The unit will be equipped with a set of meat forks.



Whole uncut chickens should always be grilled using the meat forks. This way their natural fat will baste each other, giving a perfectly slender cooking result. Refer to the You-Tube movie: “Fri-Jado instruction for binding and loading chicken”.



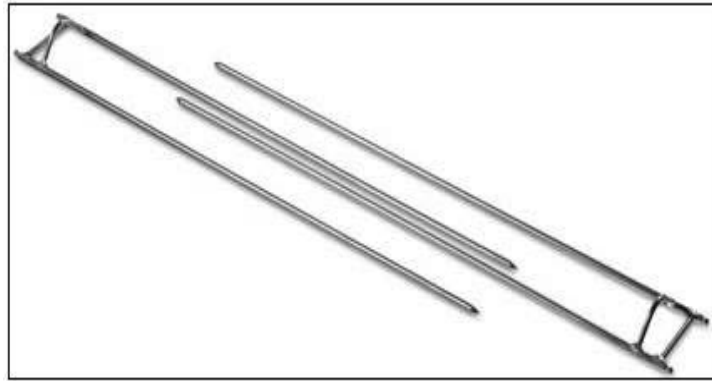

For preparing chicken or any other poultry, you can work as follows:

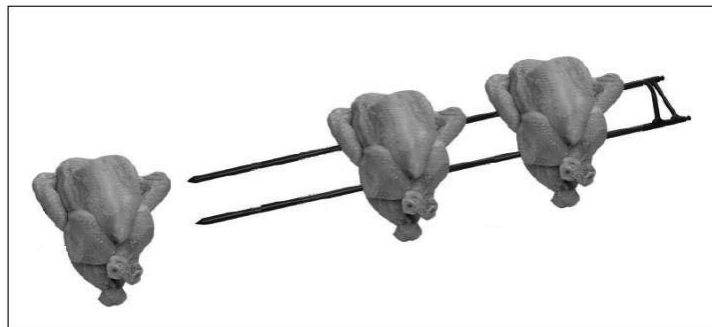

1. Insert one point of the meat fork through the chest at the position of the wings. Insert the other point through the drum sticks. Don't forget to include the wings.
2. Leave some space between the products, for an even exposure and browning.
3. Put the meat forks onto the rotor disks in such a way that during grilling the chicken breasts face the operator.
4. Put the points of the meat forks through the appropriate holes in the rotor disks.

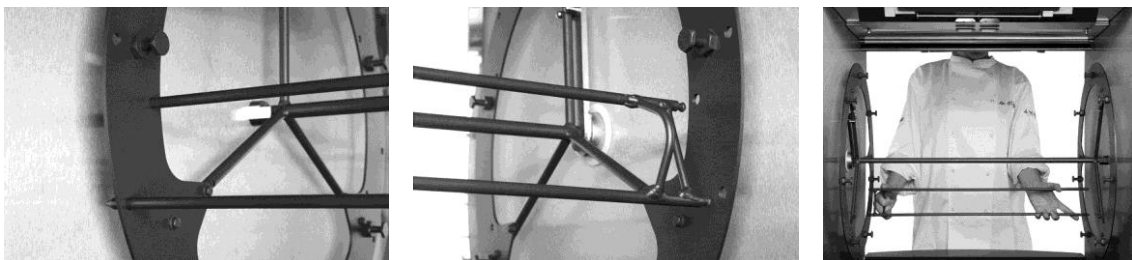

5. The other end of the meat forks must be put through the corresponding holes in the opposite rotor disk.
6. To insert the remaining meat forks in the unit, act as follows:
  - Switch-on the unit using the on/off button'.
  - With the door opened, use the rotor button to move the rotor to easily insert the next meat fork. Keep the rotor button pressed until the rotor reaches the desired position. To load the next meat fork, press the rotor button to rotate the rotor to the next loading position.
  - Repeat these steps, until all products are loaded.

### 4.3.2 Loading the rotisserie using V-shape spits (accessory)

If you are using V-shape spits act as follows:

- Place the skewer into the small outside hole on the rotor end plate on your left (as you face the oven). The back of the V-shape spit should be pointing towards you.

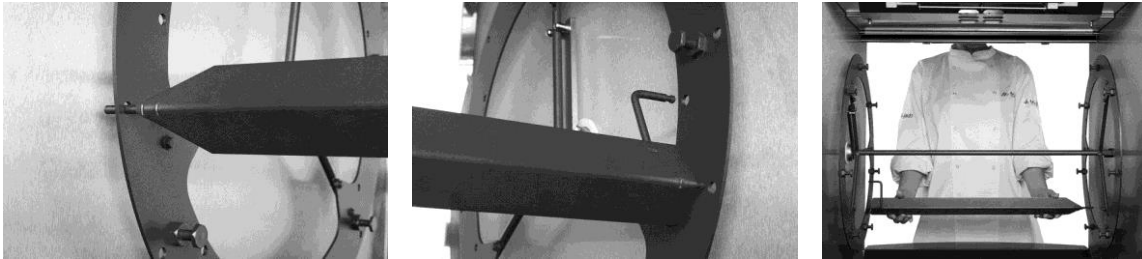

- Fit the other end on the spit into the small corresponding holes on the rotor end plate on your right (as you face the oven).
- Make sure the spit is level. If spit is not level make sure you are using the correct holes on the rotor end plates.

### 4.3.3 Loading the rotisserie using meat baskets (accessory)

If you are using meat baskets, act as follows:

- With the TDR 5 you must stick the ends of the meat baskets through the appropriate holes of the rotor disks.
- With the TDR 7 and TDR 8 you must attach the meat baskets to the appropriate pins.

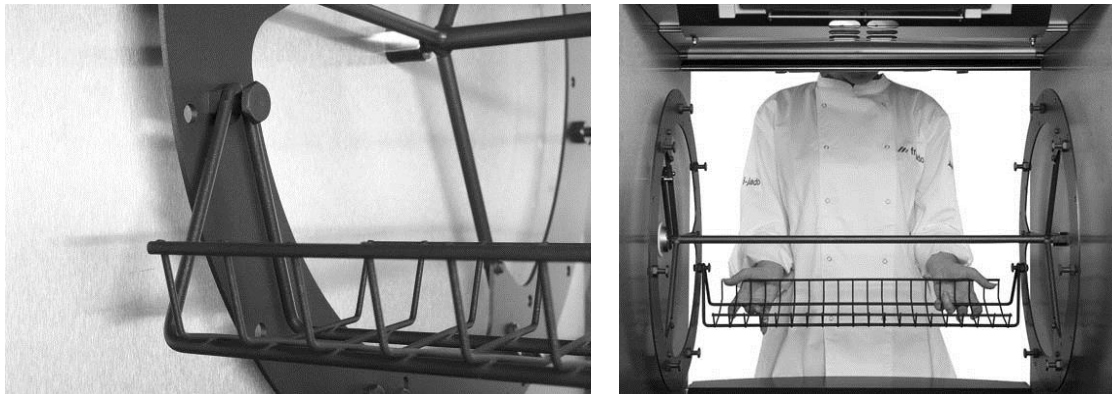

type for TDR-8 is shown

- Whilst loading the unit with meat baskets, you must see to it, that the rotor gets evenly loaded, so that the mass of the products is evenly spread over de rotor, causing an equal balance.
- Also see to it that no meat parts are sticking out of the baskets.

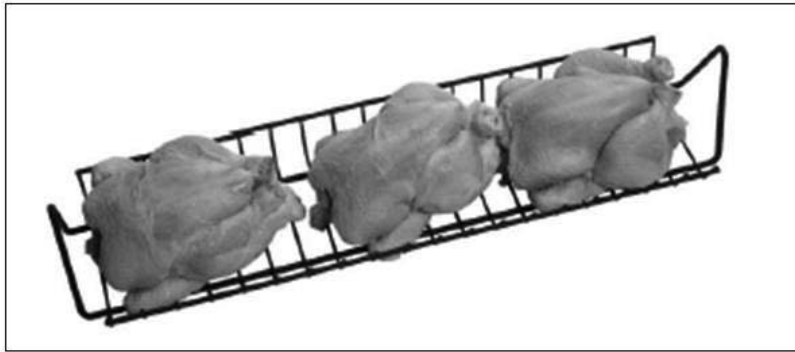

type for TDR 7 / TDR 8 is shown

#### 4.3.4 Loading the rotisserie using chicken racks (accessory)

When using chicken racks, you can use the principle as described in section 4.3.3.

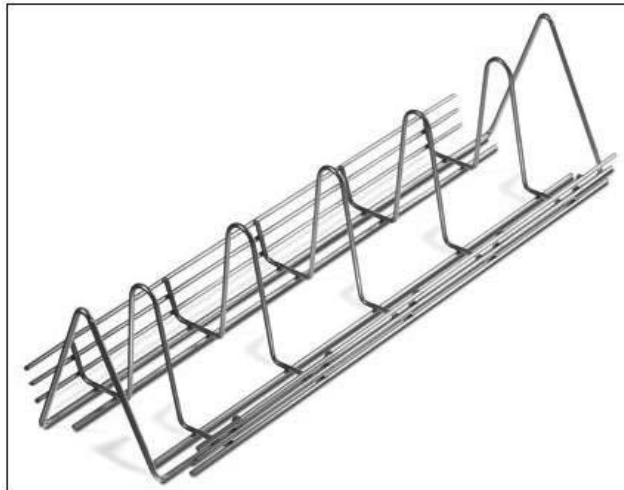

For preparing chicken or any other poultry in the racks, you can use Picture 1 as an example.



Picture 1

### 4.3.5 Loading the rotisserie using two different accessories.



**WARNING**

After loading the rotor, at least make ONE full rotation, and check whether the rotor can spin without obstructions.

If you want to load the unit using two different accessories at the same time, always fill the rotor with ONE accessory fewer than the maximum allowed quantity. See to it that accessories of the same type are placed consecutively.

**Example**

For both TDR 5 and TDR 5 + 5: 1 meat fork + 2 meat baskets consecutively.

## 4.4 Grilling



Grilling time depends on a number of factors:

- The ambient temperature and draft in the direct vicinity of the unit.
- Grilling temperature.
- The initial product temperature.
- The sort of meat (fat or lean) and with or without additives.
- The mass and shape of the product.
- The total amount of meat to be grilled in one grilling cycle.
- The end result.

### 4.4.1 Grilling temperature

Set the grilling temperature by turning the thermostat knob.

### 4.4.2 Grilling time

Set the grilling time by turning the timer knob. The unit starts instantly.

## 4.5 Taking out the products



**WARNING**

After the grilling, the interior of the unit and the glass panes are very hot. Always use oven gloves when taking out the meat forks or other accessories.

### 4.5.1 Taking out the meat forks

When taking out the meat forks, it is best to act as follows:

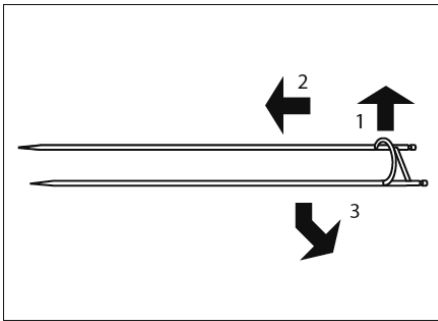

1. Hold the meat fork firmly.
2. Slightly lift the end with the grips and shift the meat fork into the direction of its points. This releases the meat fork.
3. Take the meat fork at its other end and take it out of the unit.
4. Remove the products from the meat fork.



Refer to the You-Tube movie: “Fri-Jado instruction for unloading chicken from a rotisserie”.

### 4.5.2 Taking out the V-shape spit (accessory)

For taking out the V-shape spit you can use the same principle as described in section 4.5.1.

### 4.5.3 Taking out the chicken racks (accessory).

When taking out the chicken racks from the TDR it is best to act as follows:

1. Slightly lift both ends of the chicken rack.
2. Move the rack towards either the left or right hand side of the unit. This action unlocks one end of the rack.
3. Move the unlocked end towards you, and take out the rack from the unit.

Depending on the number of prepared products, you may have to empty the racks before they can be removed.

### 4.5.4 Taking out the meat basket (accessory)

For the TDR 5 you can use the same principal as described in section 4.5.3.

For both the TDR 7 and TDR 8 it is preferred to act as follows:

1. Slightly lift both ends of the meat basket.
2. Move either one side towards you, and take out the basket from the unit.

Depending on the number of prepared products, you may have to empty the baskets before they can be removed.

#### 4.6 Emptying grease drawer



**WARNING**

Check the grease drawer after each cooking process and empty already when about half full to avoid overflowing. Push the grease drawer completely into the unit after placing it back to prevent damage to the window.



**WARNING**

Grease will be hot immediately after cooking. Allow grease to cool or use extreme caution and wear insulated gloves or safety mitts.



Drain valve open. (Handle horizontally)



Drain valve closed. (Handle vertically)

1. Open the door and slide the grease drawer out about 130 mm (5 inch).
2. Provide a suitably large bucket or vessel under drain valve and open valve handle.
3. Close drain valve when empty.
4. Push the grease drawer completely into the oven after placing it back to prevent damage to the window.
5. Close the door.

#### 4.7 Switching-off the unit

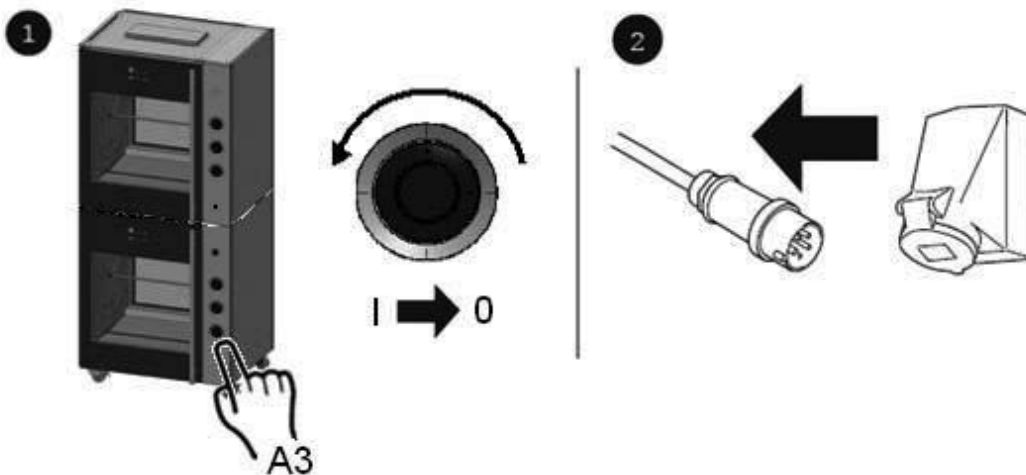

## 5. CLEANING AND MAINTENANCE



### WARNING

Appliance must be disconnected from the power supply during cleaning or maintenance and when replacing parts.

Do not use aggressive or abrasive materials. These will damage the surface which will make it more difficult to remove dirt.

Clean the inside, the removable parts and the accessories thoroughly with cleanser and water before putting the unit into use. Follow the cleaning instructions as described in this chapter.

Treat the outer surface of the interior window with a soft cleaning agent to protect the reflection layer.

Do not touch the halogen lamps with bare hands. Protect hot lamps from cold water.



### WARNING

Never use a water hose for cleaning. Water can seep into the unit through the ventilation holes of the unit.

### 5.1 Maintenance schedule

| Item                    | Action  | Frequency |
|-------------------------|---|-----------|
| Interior                | <ul style="list-style-type: none"> <li>• Clean, see section 5.2.</li> </ul>   | Daily     |
| Fat collection drawer   | <ul style="list-style-type: none"> <li>• Empty, see section 5.2.</li> </ul>   | Daily     |
| Rotor and bottom plates | <ul style="list-style-type: none"> <li>• Clean, see section 5.2.</li> </ul>   | Daily     |
| Glass panes             | <ul style="list-style-type: none"> <li>• Clean, see section 5.2.</li> </ul>   | Daily     |
| Exterior                | <ul style="list-style-type: none"> <li>• Clean, see section 5.3</li> <li>• Use Stainless Steel cleaning spray to remove stains, and restoring the gloss.</li> </ul> | Weekly    |
| Fan blade               | <ul style="list-style-type: none"> <li>• Clean, see section 5.4</li> </ul>  | Monthly   |



For hygiene matters and optimum state of your unit, it is advised to maintain a fixed daily cleaning schedule.

### 5.2 Daily Cleaning



The unit can be cleaned best shortly after use, when it is still lukewarm. Grilling residue and fat can be removed easily in this state.

The best cleaning can be achieved by using special oven- or grill cleaner.

Covering the bottom plates with aluminium foil before use, saves cleaning time

The door has a magnetic lock. Regularly check the surfaces between the door and grill, and clean if necessary, to avoid air leaks.

**Rotor and bottom plates**

- Remove the rotor and bottom plates from the unit (no tools required).
- Place the detachable parts in a wide rinsing container filled with hot water and an appropriate cleaning agent.
- Soak these parts for one night and clean them the next day.

**Fat collecting drawer**

- Carefully take out the fat collection drawer partly.
- Open the tap until the drawer is empty.
- Clean the drawer with cleaning agent or hot water combined with an appropriate cleaning agent.

**The interior**

- Clean the interior with cleaning agent or hot water combined with an appropriate cleaning agent.
- Dry the interior thoroughly by using a dry cloth. Make sure no water or detergent stays behind in the unit.

**Glass doors:**

- Open the outer glass doors
- Unlock the inner glass doors (they are magnetically locked to the outer doors).
- Clean the panes with cleaning agent or hot water combined with an appropriate cleaning agent.
- Dry the doors thoroughly by using a dry cloth.
- If possible, leave the glass doors open at night.

**5.3 Weekly Cleaning****WARNING**

The control panel may only be cleaned using a damp cloth.

Prior performing the weekly cleaning first execute the daily cleaning.

**The exterior:**

- Clean the exterior with cleaning agent or hot water combined with an appropriate cleaning agent.
- Dry the exterior thoroughly by using a dry cloth.



## 5.4 Monthly Cleaning



### WARNING

Remove the power plug from the wall socket.

Clean the fan plate and the fan blade thoroughly as described below.

#### Fan plate:

- Remove the fan plate by loosening two winged nuts. This plate hinges at two points at the sides. After pivoting, the plate can be removed from the unit.

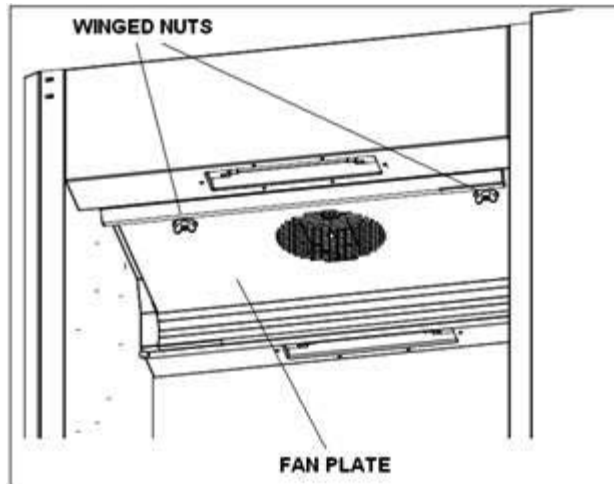

- Clean the fan plate with cleaning agent or hot water combined with an appropriate cleaning agent.
- Dry the fan plate thoroughly by using a dry cloth.

#### Fan blade:

- Clean the fan blade with a cloth and grill cleaning agent.

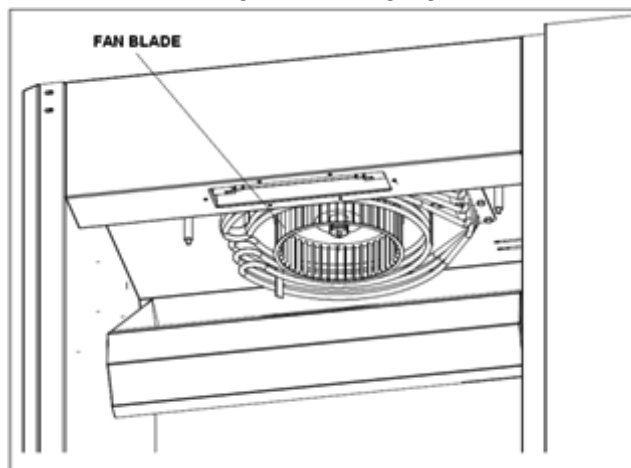

- Dry the fan blade thoroughly by using a dry cloth.

## 5.5 Cleaning guidelines for non-stick coated surfaces

Several parts of your rotisserie may have a non-stick coating surface. Abrasion and caustic chemicals reduce the life of the coating. With proper care, the non-stick coating surface should provide a long life of easy-to-clean service.

### **DO NOT do the following:**

Do not use scouring pads, steel wool, Scotch-Brite pads, plastic wash pads, or other abrasive cleaning aids (abrasive pads remove the coating over time significantly reducing the life of the coating).

Do not use sharp instruments such as knives, forks, scrapers, or metal objects of any kind.

Do not use oven cleaners.

**CAUTION:** The chemicals components of some sanitizers can attack the non-stick surface if the sanitizer is not diluted to its recommended strength causing the coating to peel.

Do not attempt to burn-off or bake-off surface contamination.

Do not operate more than eight hours without cleaning.

### **Cleaning of Non-stick Coated Surfaces (Routine Cleaning):**

1. Clean at the end of each cook cycle.
2. Allow surfaces to cool before cleaning.
3. Mix a mild dish washing soap in warm water and use a soft cloth or sponge to remove grease and food residue immediately after the coated component has cooled.
4. Rinse with clean water and let dry.
5. Wipe a light vegetable oil into the surface to condition the surface. Do not use vegetable oil cooking spray.

### **How to Clean Severe Build-up on Non-stick Coated Surfaces:**

Do not use this procedure for routine cleaning.

After successive cook cycles without cleaning, some food residues may become more difficult to remove.

If severe build-up is a regular problem, cleaning schedules should be re-evaluated.

1. Mix the following solution:

|   |
|---|
| 3 tablespoons of bleach<br>1 tablespoon liquid dish washing detergent<br>1 cup of water |
|---|

2. Use a sponge or a cloth to apply solution to affected areas. "Plastic" wash pads designed for use on non-stick cookware may be necessary for severe build-up, but never use steel pads.
3. Thoroughly rinse with clean water and let dry.
4. Condition with vegetable oil.

## 6. MALFUNCTIONS AND SERVICE

Before you contact your supplier/dealer in case of a malfunction, there are some items you can check yourself:

- Is the power supply working properly? Check fuses and differential switch.
- Has the timer clock been properly set?

| Item       | Malfunction                         | Possible action   |
|------------|-------------------------------------|---|
| Control    | Program do not start                | <ul style="list-style-type: none"> <li>• Check if both doors are closed correctly.</li> </ul>   |
| Fan        | Fan not spinning                    | <ul style="list-style-type: none"> <li>• Remove the plug from the socket.</li> <li>• Open the door.</li> <li>• Remove fan plate (see section 5.4) and check what's blocking the fan blade.</li> </ul> |
| Fan        | Noisy fan                           | <ul style="list-style-type: none"> <li>• Fan polluted, clean (see section 5.4).</li> </ul>  |
| Lamp       | Does not light up                   | <ul style="list-style-type: none"> <li>• Defect, refer to section 6.2.</li> </ul>   |
| Oven       | Product is not getting done equally | <ul style="list-style-type: none"> <li>• Try a lower cooking temperature.</li> <li>• Check fuses and/or the differential switch.</li> </ul>   |
| Oven       | The oven does not heat up           | <ul style="list-style-type: none"> <li>• Open and close door.</li> <li>• Check fuses and/or the differential switch.</li> </ul>   |
| Mains cord | Damaged                             | <ul style="list-style-type: none"> <li>• Replace, see section 6.1</li> </ul>  |

### 6.1 Replace the mains cord



**WARNING**

Hazardous electrical voltage.

If the mains cord is damaged, it must be replaced by the manufacturer, his service agent or a similarly qualified person in order to avoid hazards.

## 6.2 Replace a lamp



**WARNING**

Remove the power plug from the wall socket.



**WARNING**

Do not touch the lamps with bare hands. **Use a clean cloth or paper tissues when replacing the lamp.**

Remove any moisture with alcohol or methyl spirits after the lamp has cooled down.

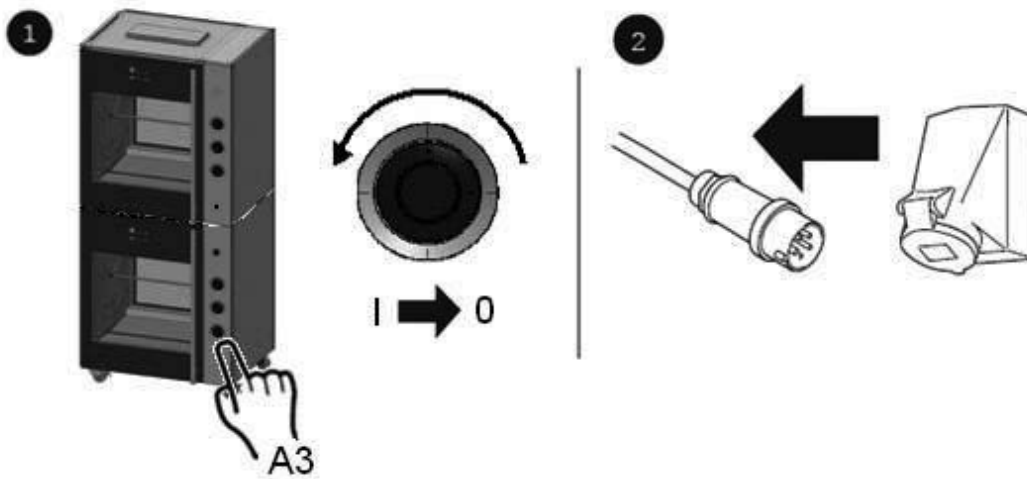

3. Remove the grid 

4. Remove the broken lamp by moving it in the length-direction of the lamp holder.

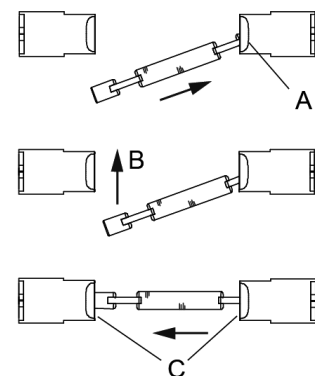
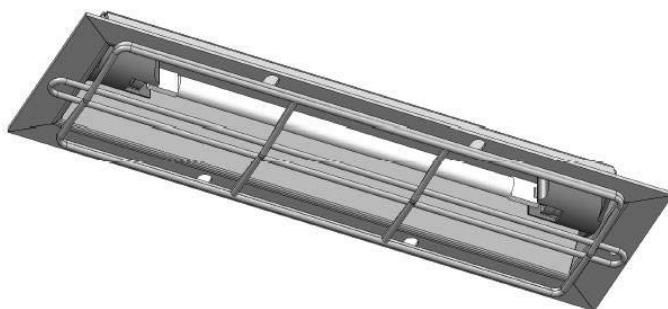

5. Install the new lamp (230 V – 500 W). First press one side of the lamp into the lamp holder (A). Press lamp in its correct position (B) and use its spring pressure to make contact with the other terminal.

6. Make sure the lamp is correctly clamped between the two terminals (C). If this is not the case, the lamp can move freely along its length-direction, until it is fixed into its terminals.

7. Remount the grid.

## 7. TECHNICAL SPECIFICATIONS

**WARNING**

Consult the identification plate to get the proper specifications of the unit. The electrical data may vary from country to country.

**European Models**

| Model                         | TDR 5         | TDR 8         | TDR 5+5       | TDR 8+8       |
|-------------------------------|---------------|---------------|---------------|---------------|
| Dimensions                    |               |               |               |               |
| - Width                       | 835 mm        | 995 mm        | 835 mm        | 995 mm        |
| - Depth                       | 710 mm        | 830 mm        | 710 mm        | 830 mm        |
| - Height                      | 895 mm        | 1050 mm       | 1775 mm       | 2080 mm       |
| Weight                        |               |               |               |               |
| - Gross                       | 160 kg        | 210 kg        | 300 kg        | 425 kg        |
| - Net                         | 130 kg        | 185 kg        | 266 kg        | 375 kg        |
| Maximum ambient temperature   | 35 °C         | 35 °C         | 35 °C         | 35 °C         |
| Sound pressure                | < 70 dB(A)    | < 70 dB(A)    | < 70 dB(A)    | < 70 dB(A)    |
| - Voltage                     | 3N~ 400/230 V | 3N~ 400/230 V | 3N~ 400/230 V | 3N~ 400/230 V |
| - Frequency                   | 50/60 Hz      | 50/60 Hz      | 50/60 Hz      | 50/60 Hz      |
| - Required power              | 6.6 kW        | 10,5 kW       | 13.2 kW       | 21 kW         |
| - Max. nom. current           | 10.0 A        | 15.5 A        | 20 A          | 31 A          |
| Plug <sup>1</sup>             | CEE-form 16 A | CEE-form 16 A | CEE-form 32 A | CEE-form 32 A |
| Length of power cable approx. | 2,20 m        | 2,20 m        | 2,20 m        | 2,20 m        |

**American Models**

| Model                         | TDR 5      | TDR 7 / TDR 8 | TDR 5+5        | TDR 7+7 / TDR 8+8 |
|-------------------------------|------------|---------------|----------------|-------------------|
| Dimensions                    |            |               |                |                   |
| - Width                       | 33 inch    | 39 ¼ inch     | 33 inch        | 39 ¼ inch         |
| - Depth                       | 28 inch    | 32 ¾ inch     | 28 inch        | 32 ¾ inch         |
| - Height                      | 35 ¼ inch  | 41 ¼ inch     | 70 inch        | 82 inch           |
| Weight                        |            |               |                |                   |
| - Gross                       | 353 lbs    | 463 lbs       | 661 lbs        | 937 lbs           |
| - Net                         | 287 lbs    | 408 lbs       | 586 lbs        | 827 lbs           |
| Maximum ambient temperature   | 95 °F      | 95 °F         | 95 °F          | 95 °F             |
| Sound pressure                | < 70 dB(A) | < 70 dB(A)    | < 70 dB(A)     | < 70 dB(A)        |
| - Voltage                     | 3~ 208 V   | 3~ 208 V      | 3~ 208 V       | 3~ 208 V          |
| - Frequency                   | 50/60 Hz   | 50/60 Hz      | 50/60 Hz       | 50/60 Hz          |
| - Required power              | 6.6 kW     | 10.5 kW       | 2x 6.6 kW      | 2x 10.5 kW        |
| - Max. nom. current           | 18.9 A     | 30.8 A        | 2x 18.9 A      | 2x 30.8 A         |
| Plug                          | NEMA15-30P | NEMA 15-50P   | 2x NEMA 15-30P | 2x NEMA 15-50P    |
| Length of power cable approx. | 75 inch    | 75 inch       | 75 inch (2x)   | 75 inch (2x)      |

<sup>1</sup> Depending on Country

## 8. ACCESSORIES

For all rotisserie models in the TDR -series mentioned in this manual, the following accessories are available:

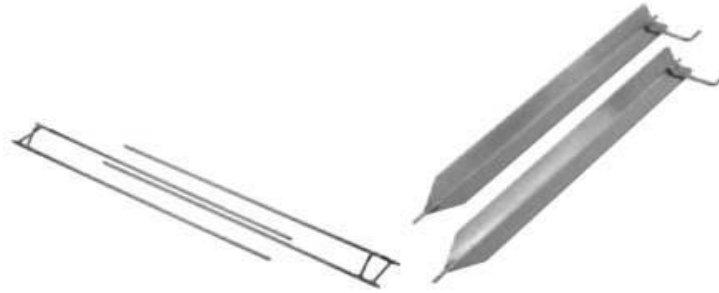

meat fork

V-spit

For the TDR 5 specifically:

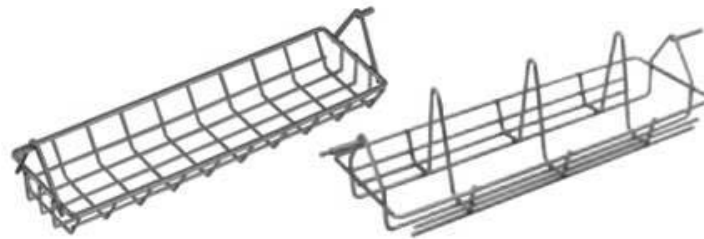

multi purpose basket

chicken rack

For the TDR 7/TDR 8 specifically:

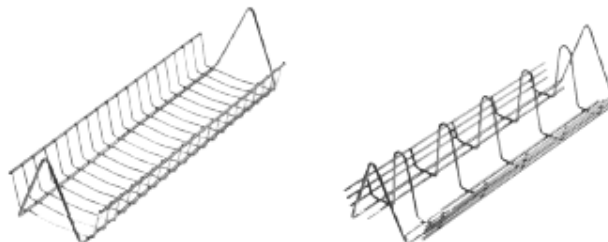

meat basket

chicken rack

Notes.

Fri-Jado Euro Products  
Oude Kerkstraat 2  
4878 AA Etten-Leur  
The Netherlands

Tel: +31 (0) 76 50 85 400  
Fax: +31 (0) 76 50 85 444