

# SERVICE MANUAL

## TG - ROTISSERIE OVEN MODELS

### MODELS

#### Manual controls

**TG50 M**  
**TG110 M**  
**TG330 M**  
**TG550 M**



**Model TG330 M**

#### - NOTICE -

This manual is prepared for the use of trained Service Technicians and should not be used by those not properly qualified. If you have attended a training for this product, you may be qualified to perform all the procedures in this manual.

This manual is not intended to be all encompassing. If you have not attended a training for this product, you should read, in its entirety, the repair procedure you wish to perform to determine if you have the necessary tools, instruments and skills required to perform the procedure. Procedures for which you do not have the necessary tools, instruments and skills should be performed by a trained technician.

Reproduction or other use of this Manual, without the express written consent of Fri-Jado, is prohibited.

EMPTY PAGE

# INDEX

<b>Index</b> .....	<b>3</b>
<b>General technical data</b> .....	<b>4</b>
Technical Data U.S. Standard Models .....	4
Technical Data U.S. Special Models .....	4
<b>Removal and replacement of parts for the TG50/110/330/550 M</b> .....	<b>5</b>
Right or left side panel TG330/550.....	5
Right side Panel TG110 .....	5
Right or left side panel TG50 .....	5
Top cover TG330/550.....	6
Top cover TG110 .....	6
Top cover TG50 .....	6
Left side panel TG110 .....	7
Knob.....	7
Control panel TG330/550 .....	7
Control panel TG110.....	8
Control panel TG50.....	8
Electric panel TG330/550 .....	9
Electric panel TG110.....	9
Quartz light .....	9
High limit thermostat.....	10
Thermostat TG330/550 .....	10
Thermostat TG110.....	11
Thermostat TG50.....	11
Timer or main switch.....	11
Timer TG50.....	12
Contactor .....	12
Blower motor.....	12
Blower motor bottom rotisserie (TG550 only).....	13
Blower motor TG50 .....	13
Heating element TG110/330/550 .....	14
Heating element TG50.....	14
Drive motor TG330/550 .....	15
Drive motor TG110.....	15
Drive motor TG50.....	16
Door adjustment TG330/550 .....	16
Door adjustment TG110 .....	17
Door glass.....	17
Changing handle of door.....	17
Changing door TG330/550 .....	18
Changing door TG110 .....	18
Changing door TG50 .....	18
Reversal of grill door TG330/550 .....	19
Reversal of grill door TG110.....	19
Reversal of grill door TG50.....	20
Changing neoprene ring of the drain plug .....	20
Changing complete drain plug .....	21
Changing fuse.....	21
Changing castor (TG550 only).....	21
Adjusting chain tension TG50 (motor side) .....	22
Replacing toothed wheel TG50 (general).....	22
Adjusting/Aligning rotor discs TG50.....	23
Drive head TG50.....	23
<b>Electrical tests</b> .....	<b>24</b>
Heating element test .....	24
Control location.....	24
Changing Quartz light functions .....	25
<b>General troubleshooting list</b> .....	<b>26</b>
Troubleshooting the TG110/330/550 M Rotisserie.....	26
Troubleshooting the TG50 M Rotisserie.....	26
<b>Analytic troubleshooting list</b> .....	<b>27</b>
Servicing and repairing of the TG110/330/550 M.....	27
Servicing and repairing of the TG50 M .....	31
<b>Exploded views &amp; Partlists</b> .....	<b>34</b>
<b>Electrical diagrams</b> .....	<b>46</b>



## GENERAL TECHNICAL DATA

This manual covers the TG series rotisserie ovens 50/110/330/550 M. These are manual controlled ovens.

- TG 50 M – Oven with three spits ( 9 chickens ).
- TG 110 M – Oven with four spits ( 16 chickens ).
- TG 330 M – Oven with seven spits ( 28 to 35 chickens ).
- TG 550 M – Double oven with both seven spits ( 56 to 70 chickens ).

All of the information, illustrations and specifications contained in this manual are based on the latest product information available at the time of printing.

### TECHNICAL DATA U.S. STANDARD MODELS

Type	TG 50	TG 110	TG 330	TG 550
Power (W)	3250	5200	9500	18000
Fuses needed with power connection 208 V, 3 ~ 60 Hz ( 3 phases without zero )	-	3x 15 A	3x 35 A	-
Fuses needed with power connection 208 V, 1N ~ 60 Hz ( 1 phase with zero )	1x 20 A	-	-	-
Standard plug from factory	NEMA 6-20P 	NEMA 15-15P 	NEMA 15-50P 	n/a (fixed wiring)
Net weight	117	165 lbs.	337 lbs.	668 lbs.
Gross weight	140	192 lbs.	395 lbs.	741 lbs.
Height	27 3/16"	29 1/2"	42 3/16"	80 15/16"
Width	22 7/16"	32 1/2"	38 13/16"	38 13/16"
Depth	19 13/16"	19 11/16"	31 1/2"	31 1/2"

### TECHNICAL DATA U.S. SPECIAL MODELS

Type	TG 110	TG 330
Power (W)	5200	9500
Fuses needed with power connection 208 V, 1N ~ 60 Hz ( 1 phase with zero )	1x 35 A	1x 60 A
Standard plug from factory	NEMA 6-50P 	n/a ( fixed wiring )

#### Tools

- Standard set of tools.
- Metric wrenches, sockets and hex socket key wrenches.
- VOM with AC current tester (any VOM with a sensitivity of at least 20,000 ohms per volt can be used).
- Insulation value tester (Megger)
- Temperature tester.

REMOVAL AND REPLACEMENT OF PARTS FOR THE TG50/110/330/550 M

**WARNING:** Disconnect the electrical power to the machine at the main circuit box. Place a tag on the circuit box indicating the circuit is being serviced.

**RIGHT OR LEFT SIDE PANEL TG330/550**



1. Remove the screws that secure the panel to the frame.
2. Remove the panel.
3. Reverse the procedure to install.

**RIGHT SIDE PANEL TG110**

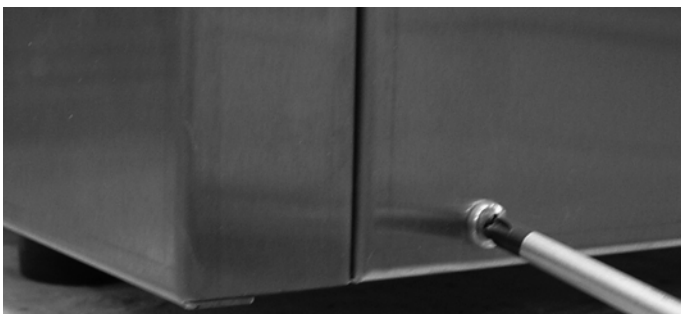

1. Remove the screws that secure the panel to the frame.
2. Remove the panel.
3. Reverse the procedure to install.

**RIGHT OR LEFT SIDE PANEL TG50**



1. Remove the screws on top and front side (behind the drawer) that secure the panel to the frame.
2. Remove the panel. Panel is hooked on back panel with socket-head screw.
3. Reverse the procedure to install.



## TOP COVER TG330/550



1. Remove the right side panel according prior procedure.
2. Remove the bolts and nuts on the inside of the top cover.
3. Remove the screws on the top cover and remove the cover.
4. Reverse the procedure to install.

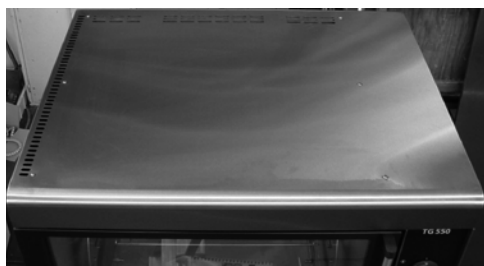

## TOP COVER TG110

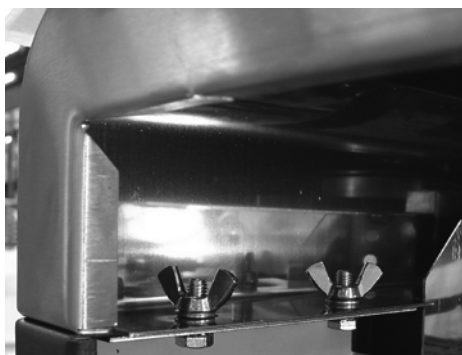

1. Remove the right side panel according prior procedure.
2. Remove the 4 wing nuts and bolts on the inside of the top cover.
3. Lift the top cover, slide it to the left and remove the cover.
4. Reverse the procedure to install.

## TOP COVER TG50

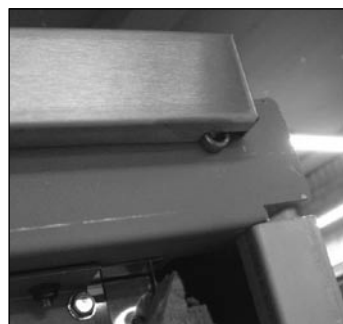

1. Remove the right and left side panel according prior procedure.
2. Remove the nuts on the inside of the top cover.
3. Lift the top cover, while supporting the door, over the hinge pin and remove the door.
4. Pull top cover towards yourself, lift this out of the fixation with the socket-head screws and remove the cover.
5. Reverse the procedure to install.

**Note:** Between the lower hinge pin and bearing lies a washer.



### LEFT SIDE PANEL TG110



1. Remove the right side panel and the top cover according prior procedures.
2. Remove the wing nuts at the top of the left side panel.
3. Allow the panel to slide down and remove it from the unit.
4. Reverse the procedure to install.

### KNOB



1. Remove cover plate on the knob with a small screw driver.
2. Loosen the screw inside the knob.
3. Remove the knob with ring.
4. Reverse the procedure to install.

**Note:** check that the ring behind the knob is in the right position and runs free from the panel.

### CONTROL PANEL TG330/550



1. Remove the right side panel according prior procedure.
2. Remove the knobs according prior procedure.
3. Remove the screws that secure the panel.
4. Loosen the wing nut from the cover box on the electric panel and remove the box.
5. Remove the bolts and nuts on the backside that secure the panel and remove the panel.
6. Reverse the procedure to install.

## CONTROL PANEL TG110



1. Remove the right side panel according prior procedures.
2. Remove the knobs according prior procedures.
3. Remove the screws that secure the panel.
4. Remove the wing nuts and bolts on the back-side that secure the panel and remove the panel.
5. Reverse the procedure to install.

## CONTROL PANEL TG50



1. Remove the fat drawer.
2. Remove the knobs according prior procedure.
3. Remove the screws that secure the front panel and remove the front panel.
4. Remove the 4 screws on the front side and the nut on the back side and remove the panel.
5. Reverse the procedure to install.



### ELECTRIC PANEL TG330/550

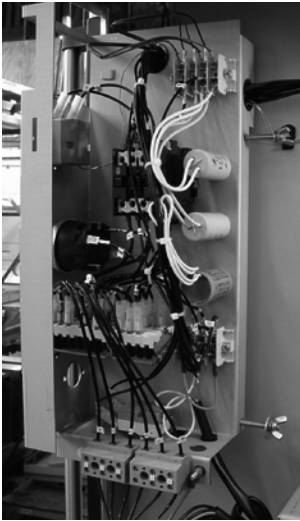

1. Remove the knobs according prior procedure.
2. Remove the screws on the front side that secure the panel.
3. Remove the cover box on the electric panel according prior procedure.
4. Disconnect all necessary wiring.
5. Remove the wing nuts that secure the electric panel and slide panel to the right to remove the panel.
6. Reverse the procedure to install.

### ELECTRIC PANEL TG110

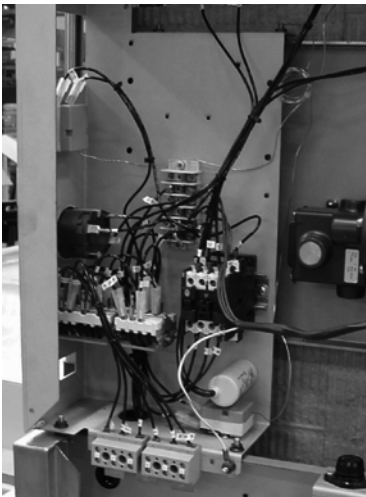

1. Remove the control panel according prior procedure.
2. Disconnect all necessary wiring.
3. Remove the nuts that secure the electric panel and remove the panel.
4. Reverse the procedure to install.

### QUARTZ LIGHT

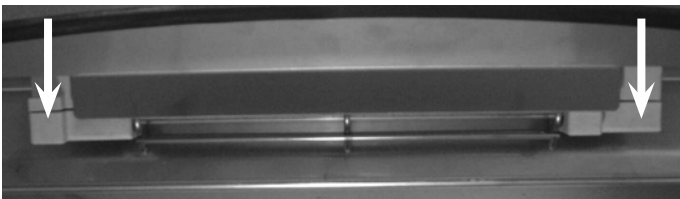

TG330/550



TG110

1. Remove the insulators of the lamp.
2. Remove the bolt from each end of the lamp and remove the lamp.
3. Install the lamp with the painted side towards the top of the oven. Hold the metal ends when tightening the bolts to prevent the metal from twisting and damaging the lamp.
4. Tighten the insulators evenly to prevent damage.

**Caution:** Do not touch the glass with your hands. The moisture from your hands could affect the live span of the lamp. This moisture can be removed with alcohol while the lamp is cold.

**Note:** Use a clean rag or paper towel to replace the lamp.

## HIGH LIMIT THERMOSTAT

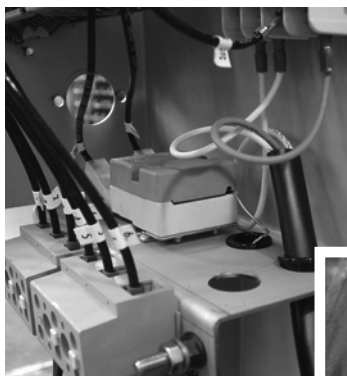

TG330/550

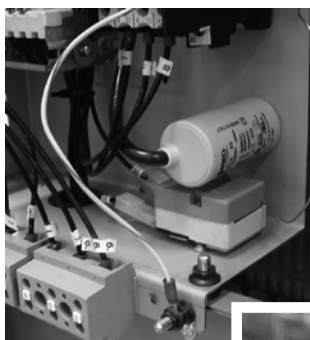
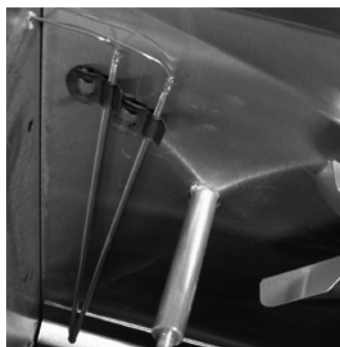

TG110



1. Remove the right side panel according prior procedure.
2. (TG 330-550 only) Remove the suction and fan plate on the inside of the oven.
3. (TG 110 only) Remove the nut on the clamp and slide clamp towards yourself. Loosen the screw in the clamp that secures the probe and remove the probe.
4. (TG 330-550 only) Remove the thermostat-probe from the clip in the oven and guide it outside through the opening in the side wall.
5. Remove the screws on the electric panel that secure the thermostat.
6. Remove the thermostat and disconnect the wiring.
7. Reverse the procedure to install.

**Note:** Set the new high limit thermostat to its maximum position.

## THERMOSTAT TG330/550

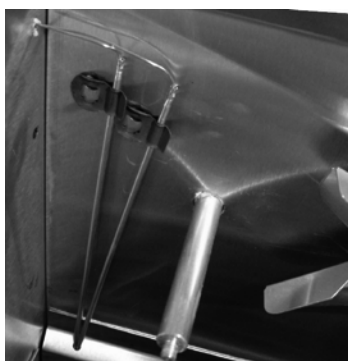

1. Remove the control panel cover and the suction and fan plate according prior procedures.
2. Remove the thermostat-probe from the clip in the oven and guide it outside through the opening in the side wall.
3. Remove the screws on the electric panel that secure the thermostat.
4. Remove the thermostat and disconnect the wiring.
5. Reverse the procedure to install.

**THERMOSTAT TG110**



1. Remove the control panel according prior procedure.
2. Remove the nut on the clamp and slide clamp towards yourself. Loosen the screw in the clamp that secures the probe and remove the probe.
3. Remove the screws on the electric panel that secure the thermostat.
4. Remove the thermostat and disconnect the wiring.
5. Reverse the procedure to install.

**THERMOSTAT TG50**

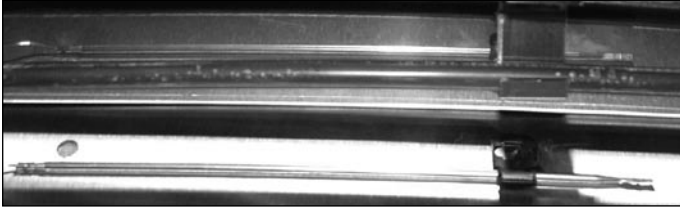

1. Remove the front panel and the left side panel according prior procedures.
2. Remove the cap nuts that secure the fan plate and remove this plate.
3. Remove the thermostat-probe from the clip in the oven and guide it outside through the opening in the side wall.
4. Remove the screws on the control panel that secure the thermostat.
5. Remove the thermostat and disconnect the wiring.
6. Reverse the procedure to install.

**TIMER OR MAIN SWITCH**



1. Remove the control panel according prior procedure.
2. Remove the screws on the electric panel that secure the switch.
3. Remove the switch and disconnect the wiring.
4. Reverse the procedure to install.

## TIMER TG50



1. Remove the control panel according prior procedure.
2. Remove the screws on the electric panel that secure the timer.
3. Remove the timer and disconnect the wiring.
4. Reverse the procedure to install.

## CONTACTOR

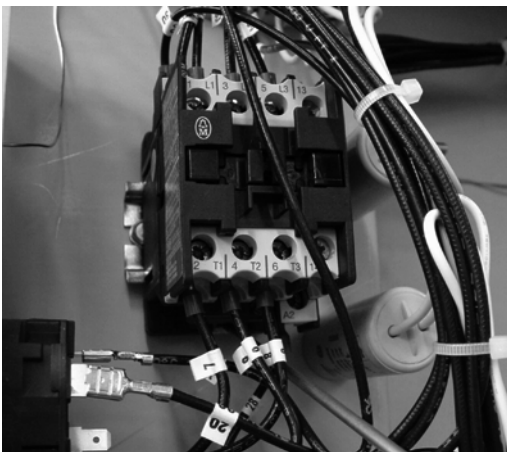

1. Remove the right side panel according prior procedure.
2. Disconnect the lead wires to the switch.
3. Push down on the locking tab and lift out and then up to remove it from the mounting bracket.
4. Reverse the procedure to install.

## BLOWER MOTOR

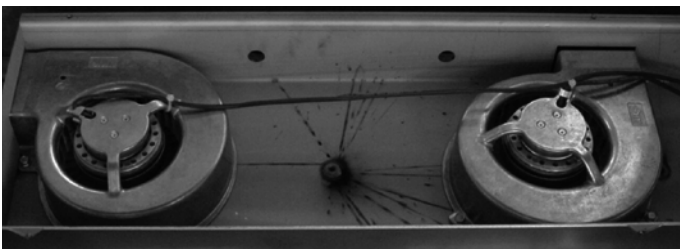

TG330/550

1. Remove the right side panel and the top cover according prior procedures.
2. Remove the rotor discs, suction and fan plate in the oven.
3. Remove the wing nut on the fan blade and remove fan blade. (Left handed threads).
4. Disconnect wiring of the motor.
5. Remove the screws that secure the motor and remove the motor.
6. Reverse the procedure to install.

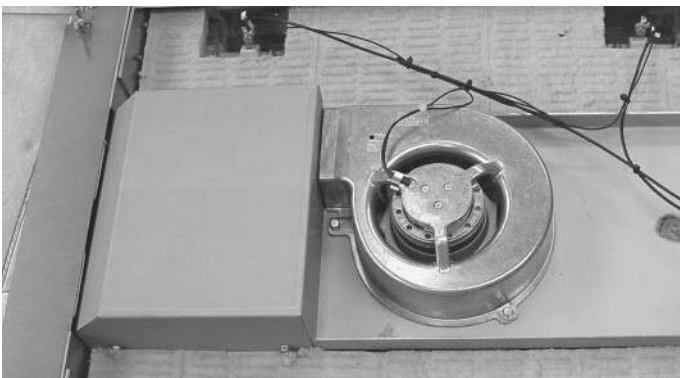

TG110

**Note:** The blowers of TG 330-550 are equipped with a capacitor. Check the direction of rotation of the motor (clockwise) and change the wiring if necessary.

## BLOWER MOTOR BOTTOM ROTISSERIE (TG550 ONLY)



1. Remove the right side panel according prior procedures.
2. Remove the rotor discs, suction and fan plate in the bottom oven.
3. Remove the wing nut on the fan blade and remove fan blade. (Left handed threads!)
4. Remove fat drawer from upper oven.
5. Remove the drip trays from the upper oven.
6. Remove the 4 screws that secure the intermediate plate above the blowers and slide this plate off to the service side.
7. Disconnect wiring of the motor.
8. Remove the screws that secure the motor and remove the motor.
9. Reverse the procedure to install.

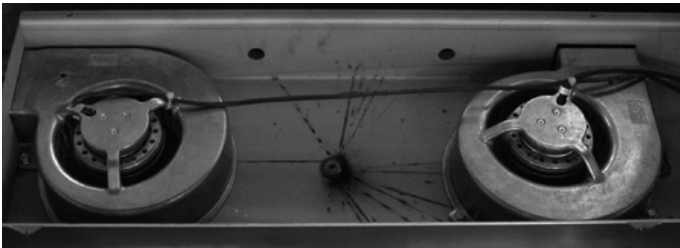

**Note:** The blowers are equipped with a capacitor. Check the direction of rotation of the motor (clockwise) and change the wiring if necessary.

## BLOWER MOTOR TG50

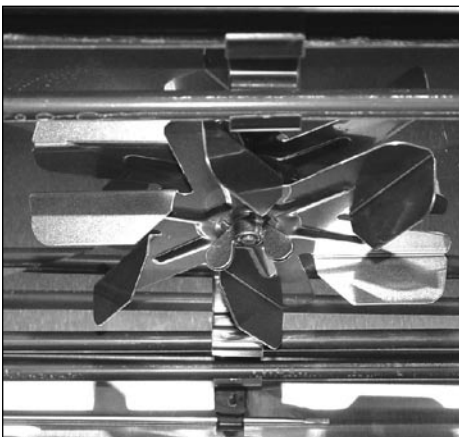

1. Remove the right and left side panel and the top cover according prior procedures.
2. Remove the fan plate in the oven.
3. Remove the wing nut on the fan blade and remove fan blade. (Left handed threads).
4. Disconnect wiring of the motor.
5. Remove the screws that secure the motor and remove the motor.
6. Reverse the procedure to install.



## HEATING ELEMENT TG110/330/550



TG330/550



TG110

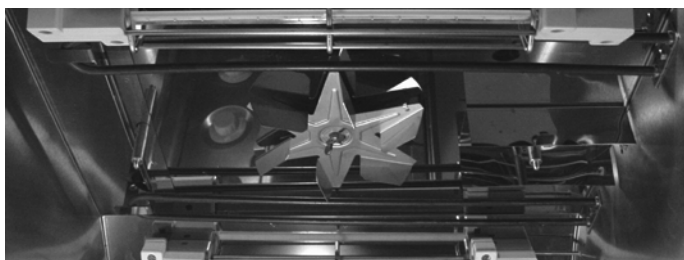

1. Remove the rotor discs, right side panel, suction and fan plate according prior procedures.
2. Disconnect the wiring from the element.
3. Remove the mounting nut.
4. Remove the element from the mounting clip and pull it from the wall.
5. Reverse the procedure to install.

## HEATING ELEMENT TG50

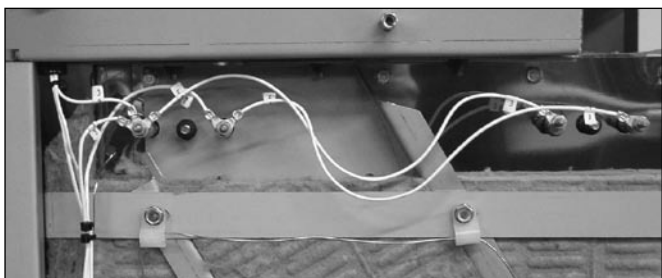

1. Remove the left side panel and fan plate according prior procedures.
2. Disconnect the wiring from the element.
3. Remove the mounting nut.
4. Remove the element from the mounting clip and pull it from the wall.
5. Reverse the procedure to install.

## DRIVE MOTOR TG330/550

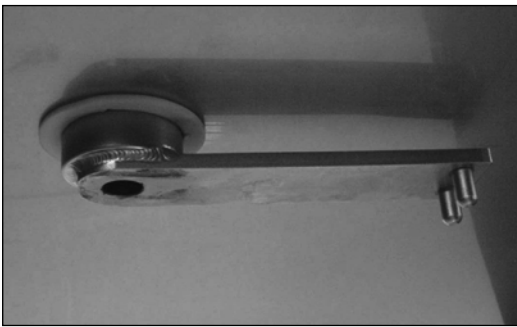
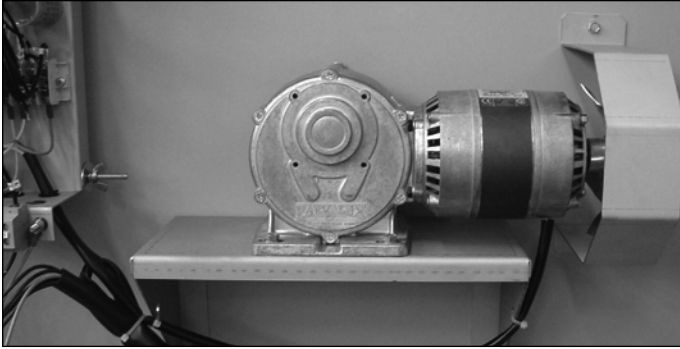

1. Remove the right side panel and rotor discs according prior procedures.
2. Disconnect the wiring of the motor. Check where the wire, marked A is connected.
3. Remove the screws that secure the fan cover and remove the cover.
4. Set the drive arm in horizontal position towards the service side. You can do this by manual operation or by turning the fan blade by hand.
5. Mark the position of the motor support with a marker.
6. Remove the bolts that secure the motor and the nuts that secure the motor support and remove the motor.
7. Check the white Teflon ring. Replace if necessary.
8. Install the fan blade on the new motor.
9. Reverse the procedure to install.

**Note:** Always make a test run on maximum temperature to insure the motor is well mounted and adjusted.

## DRIVE MOTOR TG110



1. Remove the right side panel and rotor discs according prior procedures.
2. Disconnect the wiring of the motor.
3. Remove the bolts that secure the motor and remove the motor.
4. Check the white Teflon ring. Replace if necessary.
5. Reverse the procedure to install.

**Note:** Always make a test run on maximum temperature to insure the motor is well mounted and adjusted.

## DRIVE MOTOR TG50



1. Remove the left side panel according prior procedure.
2. Remove the screws that hold the back panel and remove this panel.
3. Remove the 4 screws on the bottom side that secure the motor.

**Note:** If necessary release the tension on the chain.

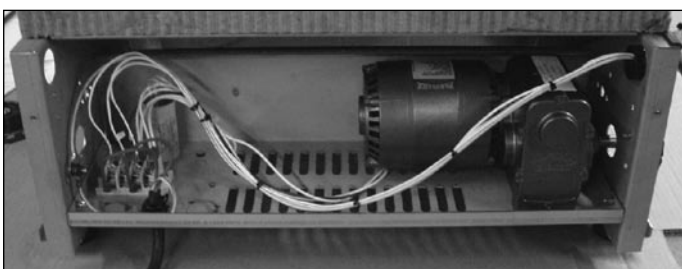

5. Measure how far the toothed wheel is mounted on the motor shaft.
6. Loosen the socket-head bolt that secures the toothed wheel and remove this wheel.
7. Remove the key from the motor shaft.
8. Disconnect the wiring of the motor and remove the motor. Check where the wire, marked A, is connected.
9. Reverse the procedure to install.

**Note:** Always make a test run on maximum temperature to insure the motor is well mounted and adjusted.

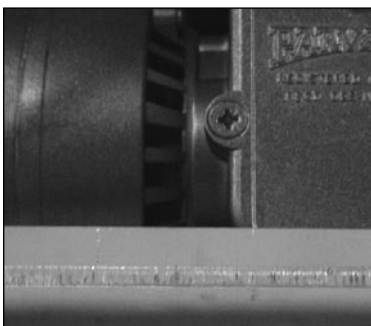

## DOOR ADJUSTMENT TG330/550



1. Open the door and loosen the bolts on top side that secure the hinge plate.
2. Adjust the hinge and tighten the bolts.



## DOOR ADJUSTMENT TG110



1. Remove the left side panel according prior procedure.
- 2a. Loosen the 2 bolts on the hinge to adjust the door in horizontal way.
- 2b. Loosen the 4 bolts on the reinforcement plate to adjust the door in the depth.
3. Reverse the procedure to install.

## DOOR GLASS



1. Remove the retaining strip from the handle edge while supporting the glass.
3. Loosen the nuts of the retaining strip on the hinge side of the door and remove the glass.
4. Install the glass with the painted strips to the outside of the unit due to the reflective coating on the inside of the glass.
5. Install the retaining strip on the handle side of the door and tighten the nuts.
6. Adjust door if necessary as described under "door adjustment".

## CHANGING HANDLE OF DOOR



1. Secure the window by means of adhesive tape.
2. Remove the retaining strip from the handle edge.
3. Remove the screw that secures the holder for the handle on the bottom side and remove the holder and handle.
4. Reverse the procedure to install.

## CHANGING DOOR TG330/550



1. Open the door and remove the bolts that secure the hinge plate, while supporting the door, and remove the plate.
2. Lift the door to remove the lower hinge pin from the bearing.
3. Reverse the procedure to install.

**Note:** *Between the lower hinge pin and bearing lies a washer.*

## CHANGING DOOR TG110



1. Remove the left side panel according prior procedure.
2. Remove the 2 bolts that secure the hinge, while supporting the door.
3. Open and lift the door to remove the lower hinge pin from the bearing.
4. Reverse the procedure to install.

**Note:** *Replace top bearing to new door. Between the lower hinge pin and bearing lies a washer.*

## CHANGING DOOR TG50



1. Remove the left and right side panel and the top cover with door according prior procedures.
2. Place new door and reverse the procedure to install.

**Note:** *Between the lower hinge pin and bearing lies a washer.*



## REVERSAL OF GRILL DOOR TG330/550

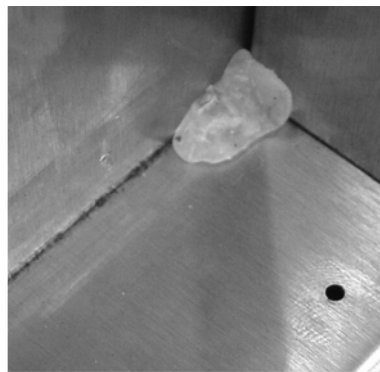
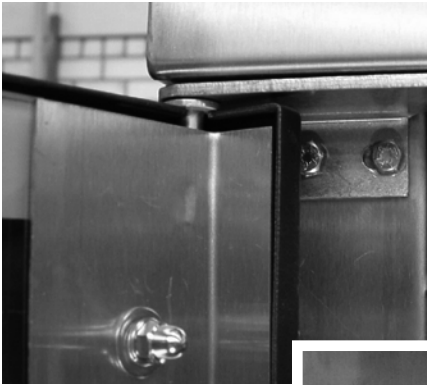

1. Follow procedure of "changing door" point 1 and 2.
2. Drill a hole of 10 mm in the pilot hole on the handle side of the frame and replace the bearing (part nr.0602072).
3. Replace the bearing (part nr. 0602072) in the hinge plate to the other side of the hinge.
4. Place the washer on the bearing.
5. Rotate the door 180° and insert the hinge pin into the washer and bearing.
6. Mount the hinge plate on the right side, adjust the door and tighten the bolts.
7. Put a plastic plug (part nr. 9087350) in the hole on the left side and tighten the 2 screws in the top.

## REVERSAL OF GRILL DOOR TG110

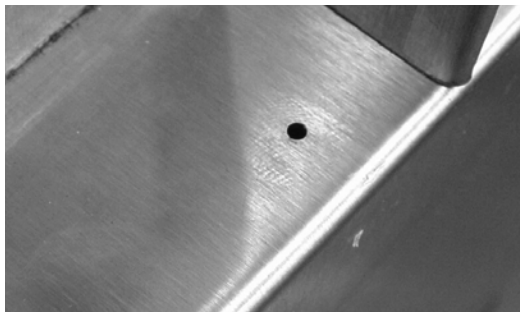

For this procedure you need to order the following parts:

1x hinge plate	9041273
1x tap plate	9041061
2x bolt M5x12	0211520
2x serrated washer	0142030
1x brass bearing	0602072
1x plastic plug	9087350

1. Follow procedure of "changing door" point 1 to 3.
2. Drill a hole of 10 mm in the pilot hole on the handle side of the frame and replace the bearing.
3. Mount the new hinge plate on the right side on the tap plate with 2 bolts M5x12 and serrated washers. Do not tighten this yet.
4. Place the washer on the bearing on bottom side.
5. Rotate the door 180° and insert the hinge pin in the washer and bearing.
6. Adjust the door and tighten the bolts.
7. Put a plastic plug (part nr. 9087350) in the hole on the left side.

**Note:** It is necessary to make a small opening in the top cover to allow the hinge to pass through. Leave the original hinge on its place, just remove the bearing.

## REVERSAL OF GRILL DOOR TG50

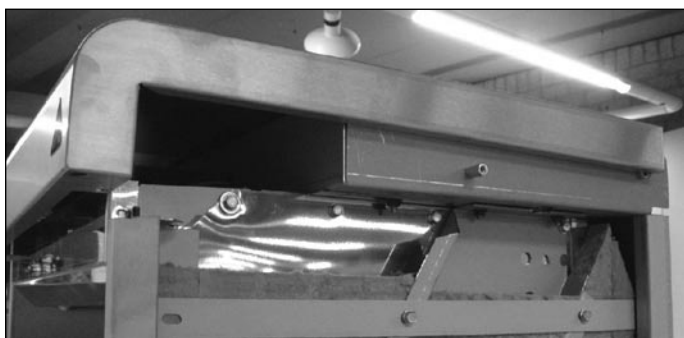

1. Follow procedure of "changing door".
2. Drill a hole of 10 mm in the pilot hole on the handle side of the frame and replace the bearing (part nr.0602072).
3. Replace the bearing (part nr. 0602072) in the top cover to the other side.
4. Place the washer on the bearing.
5. Rotate the door 180° and insert the hinge pin into the washer and bearing.
6. Mount the top cover over the door pin and tighten the nuts.
7. Mount the left and right side panels.
8. Put a plastic plug (part nr. 9087350) in the hole on the left side.

## CHANGING NEOPRENE RING OF THE DRAIN PLUG



1. Open fat drawer and remove bolt at bottom side.

**Note:** The bolt is tightened with Loctite on the first 2 threads.

2. Unlock the drain plug by means of the wing nut and remove the ring.
3. Reverse the procedure to install.

**Note:** Before mounting the bolt put Loctite on the first 2 threads.

## CHANGING COMPLETE DRAIN PLUG

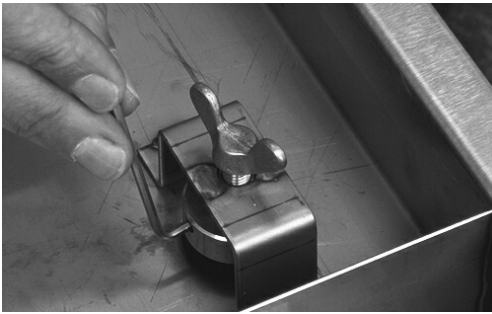

1. Open fat drawer and loosen the plug by means of the wing nut.
2. Loosen the setscrew of the wing nut on the brass ring.
3. Remove drain plug by unscrewing the wing nut.
4. Reverse the procedure to install.



**Note:** Before mounting put Loctite on the first 2 threads of the bolt and in the brass ring.

## CHANGING FUSE

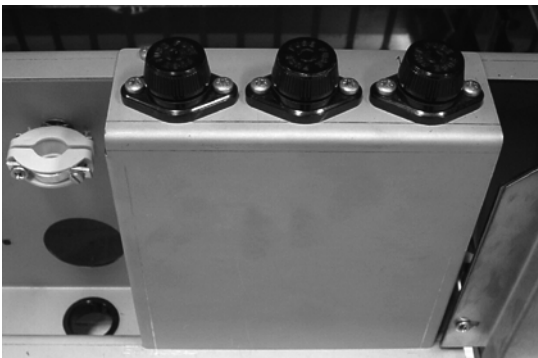

1. Remove the right side panel according prior procedure.
2. Remove cover from fuse holder and replace the fuse.

## CHANGING CASTOR (TG550 ONLY)

1. Loosen the 4 bolts and slide the castor with mounting plate from the base frame.

**Note:** The castors on the front side are with brake and on the backside without break.

2. Remove the bolts from the mounting plate.
3. Reverse the procedure to install.

## ADJUSTING CHAIN TENSION TG50 (MOTOR SIDE)



1. Remove the left side panel according prior procedure.
2. Loosen the 2 screws that secure the chain stretcher.
3. Adjust the chain tension with the bolt on top of the chain stretcher.
4. Secure the bolt by means of the nut.
5. Mount left side panel.
6. Make a test run.

## REPLACING TOOTHED WHEEL TG50 (GENERAL)



1. Remove the left or right side panel according prior procedure.
2. Release the chain tension with the chain stretcher.
3. Measure how far the toothed wheel is mounted on the shaft.
4. Replace the toothed wheel.

## ADJUSTING/ALIGNING ROTOR DISCS TG50



1. Remove the left side panel according prior procedure.
2. Loosen the clamp nut on the front shaft.
3. Put a spit between the rotor discs and align the discs by turning the right side disk.
4. Reverse the procedure to install.



## DRIVE HEAD TG50



1. Remove the left or right side panel according prior procedure.
2. Release the chain tension with the chain stretcher.
3. Remove the disc in the oven.
4. Measure how far the toothed wheel is mounted on the shaft.
5. If necessary, remove the insulation for easy access to the bolts of the housing.
6. Remove the nuts that secure the housing and remove the housing.
7. Loosen the socket-head bolt that secures the toothed wheel and remove the wheel.
8. Remove the clip on the shaft and remove the drive head.
9. Reverse the procedure to install.



## ELECTRICAL TESTS

**WARNING:** Disconnect the electrical power to the machine at the main circuit box. Place a tag on the circuit box indicating the circuit is being serviced.

## HEATING ELEMENT TEST

Type	Wattage/Voltage	Resistance $\Omega$ -5% + 10%	Current A
TG50	1000 / 200	40.0	5.0
	1000 / 230	53.0	4.3
TG110	1500 / 208	29.0	7.2
	1500 / 230	35.5	6.5
TG330/550	2100 / 208	20.5	10.0
	2100 / 230	25.0	9.1
TG330/550	3100 / 208	14.0	14.9
	3100 / 230	17.0	13.4

**Note:** When testing the resistance of the element remove the wiring.

## CONTROL LOCATION

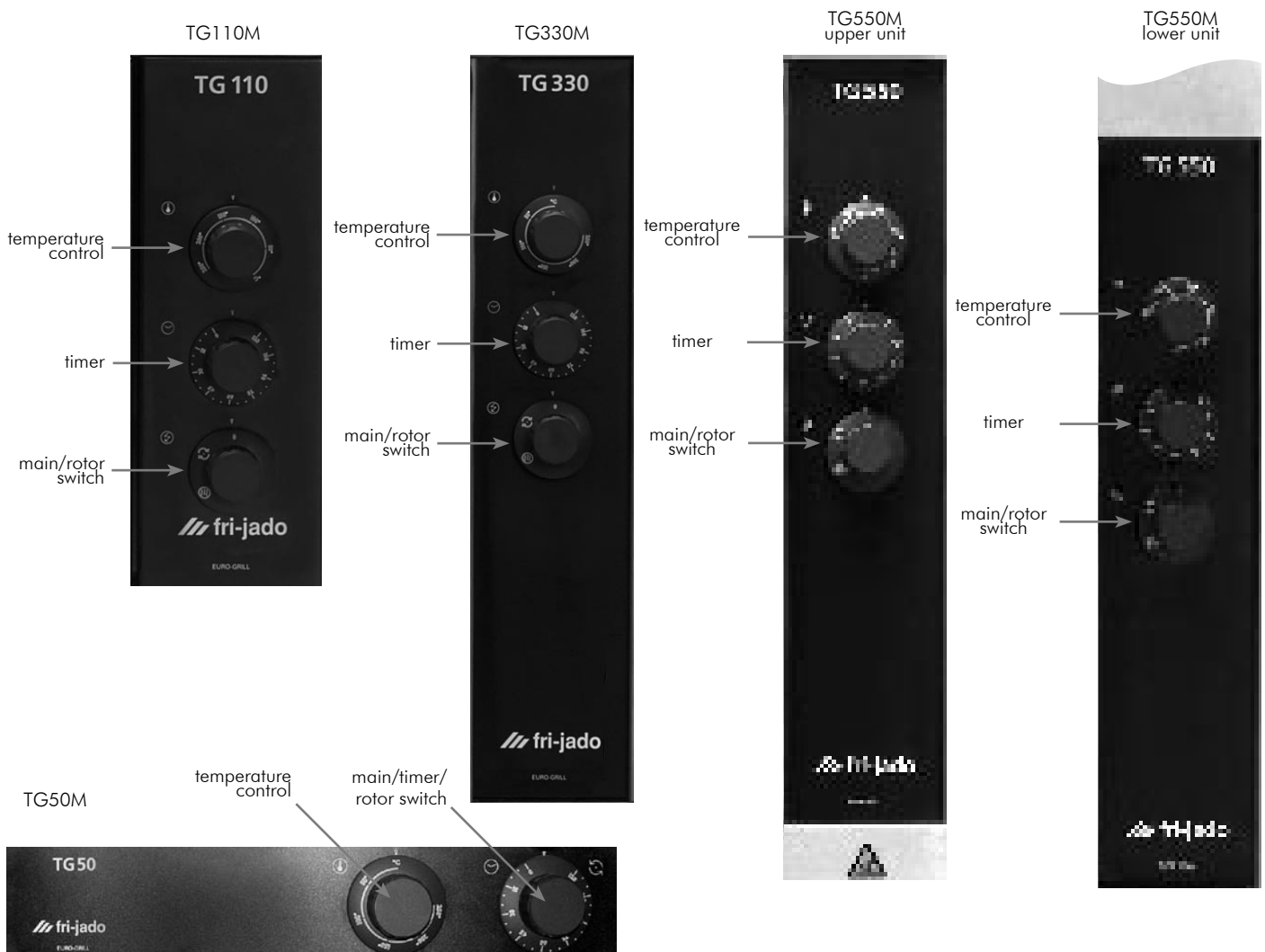



## CHANGING QUARTZ LIGHT FUNCTIONS

For the standard rotisseries (with doors on both sides) the Quartz light on customer side is always on during the process and the light on service side switches on and off with the heating elements. In some cases it is desirable that the lights work the other way around. To do this you have to change the wiring of the Quartz lights. Below is described how to do this with the different rotisseries. See also the circuit and wiring diagrams.

### TG 110 M:

Change the wires 36+M2 on the Quartz light on customer side with the wire 33 on the Quartz light on service side.

### TG 330 and 550 M 3~208V:

Change the wire 23 on the main switch with the wire 25 on the connection block.

Change the wire 24 on the contactor with the wire 36 on the connection block.

### TG 330 M 1N~208V:

Change the wire 24 on the contactor with the wire 36 on the connection block.

## GENERAL TROUBLESHOOTING LIST

## TROUBLESHOOTING THE TG110/330/550 M ROTISSERIE

Symptom	Possible causes
Main fuse or breaker blows	<ol style="list-style-type: none"> <li>1. Wiring incorrectly.</li> <li>2. Heating element, drive motor, blower or contactor shorted.</li> <li>3. Wiring shorted.</li> </ol>
Drive motor does not run.	<ol style="list-style-type: none"> <li>1. Main fuse on L3 inoperative.</li> <li>2. Capacitor malfunction.</li> <li>3. Motor malfunction.</li> <li>4. Main switch malfunction.</li> <li>5. Timer switch malfunction.</li> <li>6. Fuse F 1 or F 2 burned.</li> <li>7. Wiring loose.</li> </ol>
Blower motor does not run.	<ol style="list-style-type: none"> <li>1. Capacitor malfunction.</li> <li>2. Wiring loose.</li> <li>3. Motor inoperative.</li> </ol>
Overtemperature differs from temperature setting in manual mode.	<ol style="list-style-type: none"> <li>1. Incorrect line voltage.</li> <li>2. Thermostat malfunction.</li> <li>3. Blower motor(s) inoperative.</li> <li>4. Dirty fan guard or fanblade(s).</li> </ol>
All heating elements out, one quartzlamp and blowers operate while oven cavity is below set temperature.	<ol style="list-style-type: none"> <li>1. Thermostat malfunction (open).</li> <li>2. Contactor inoperative.</li> <li>3. Wiring loose.</li> <li>4. Main switch malfunction.</li> </ol>
Oven temperature does not reach desired temperature.	<ol style="list-style-type: none"> <li>1. Thermostat malfunction.</li> <li>2. Heater(s) inoperative.</li> <li>3. Incorrect voltage line.</li> </ol>

## TROUBLESHOOTING THE TG50 M ROTISSERIE

Symptom	Possible causes
Drive head does not run.	<ol style="list-style-type: none"> <li>1. Main fuse open.</li> <li>2. Capacitor malfunction.</li> <li>3. Motor malfunction.</li> <li>4. Timer switch malfunction.</li> <li>5. Wiring loose.</li> <li>6. Chain broken.</li> <li>7. Chainwheel loose.</li> </ol>
Oven temperature differs from temperature setting.	<ol style="list-style-type: none"> <li>1. Thermostat malfunction.</li> <li>2. Blower motor inoperative.</li> <li>3. Dirty fanguard or fanblade.</li> <li>4. Thermostat probe loose.</li> </ol>
Oven temperature does not reach desired temperature.	<ol style="list-style-type: none"> <li>1. Thermostat malfunction.</li> <li>2. Heater(s) inoperative.</li> </ol>

## ANALYTIC TROUBLESHOOTING LIST

**SERVICING AND REPAIRING OF THE TG110/330/550 M**

This is an analytic description for servicing and repairing all major parts of the rotisseries and warmers. It consists off 4 basic steps to recognize and solve the problems. These steps are:

1. Symptoms.
2. Possible causes.
3. Solving of the problem: checking/action.
4. Replacing of parts and testing.
  - a. Replacing is described in the service manual.
  - b. For testing see programming of rotisserie on page 5 in this manual.

Description of part	Symptoms	Possible causes	Solving: checking/action
<b>Door</b>	Broken glass	Slamming of door.	Give instruction to operator.
		Fastening bolts and nuts are loose.	Tighten all fastenings.
	Door adjustment	Door not well adjusted and closes against bottom side.	Adjust door on hinge and tighten the hinge plate.
<b>Heating element</b>	Rotisserie doesn't reach adjusted temperature	Wiring.	Check the wiring.
			Check the power on the element.
	Duration of grilling time is too long	Element malfunction.	Check the current with AC current tester. See table on page 24.
		Wiring.	Check the wiring.
<b>Thermostat</b>	Contactor doesn't come in after starting of program	Wiring.	Check the wiring.
		Thermostat malfunction.	Check if the thermostat is making contact.
	Contactor switches off before reaching the adjusted temperature in program	Thermostat malfunction.	Check if the safety thermostat on the inside is turned fully clockwise (contact closed).
		Thermostat probe not in right position.	Check the position of the thermostat probe.
<b>Main switch</b>	No power to all, or some oven controls	Wiring.	Check the wiring on the switch.
		Malfunction of the cams on the switch.	Check the cams.
		Contacts burned.	Check the contacts on the switch.

Description of part	Symptoms	Possible causes	Solving: checking/action
<b>Timer</b>	No functions of oven are working	Wiring.	Check the wiring on the switch. Check the power on the switch.
		Malfunction of the timer.	Check functions after connecting a new timer.
	Grilling process is working, but doesn't stop	Malfunction of the timer.	Check if the time is running down on timer (does it tick). Check if the timer switches off after reaching the zero position.
<b>Contactor</b>	Contactor doesn't come in	Wiring.	Check the wiring.
		Coil malfunction.	Check resistance of the coil. This should be $\pm 525\Omega$ .
	Contactor comes in, but one or more functions from the switch don't work	Contact burned.	Check the wiring.
			Check the power on all contacts. Check the contacts of the switch.
<b>Capacitor</b>	Drive motor or blower doesn't work	Wiring.	Check the wiring.
		Capacitor malfunction.	Check function after connecting a new capacitor. Checking of capacitor: Discharge capacitor with screwdriver. Set meter on $M\Omega$ and connect the pins of the meter on contacts, value runs up. Change the pins on contacts, value runs up again. This means the capacitor is OK.  Another test is to charge the capacitor with a Megger on 250V and first check the insulation value. Wait for a minute and discharge the capacitor with a screw driver. When it still flashes it means the capacitor is OK.

Description of part	Symptoms	Possible causes	Solving: checking/action
Drive motor	Motor doesn't run	Wiring.	Check the wiring. Check the power to the motor.
		Coil malfunction.	Check resistance of the coils. TG 330 and 550: Between whiteA and white wire $\pm 234\Omega$ Between whiteA and brown wire $\pm 117\Omega$ Between white and brown wire $\pm 117\Omega$ TG 110: Between all wires $\pm 67\Omega$
		Reduction gearbox.	Check if reduction gearbox is blocked.
	Motor runs after starting it up by hand	Capacitor malfunction.	Check capacitor (see capacitor) or connect new capacitor.
	Motor stops during process and comes in again after a period of time	Coil overheated, thermistor switches off (105°C – 221°F).	Check position of fan blade. Air is sucked up over the motor.
			Check cooling circuit of motor.
			Check if rotisserie is close to another heat source.
	Measure temperature motor during process.		
Fuse F1 or F2 burned	Short circuit in coil to earth.	Check insulation value of coil with Megger on 500V. Minimum value is 0.5 M $\Omega$ .	

Description of part	Symptoms	Possible causes	Solving: checking/action
<b>Blower TG 330-550</b>	Blower doesn't run	Wiring.	Check the wiring.
			Check the power on the blower.
		Coil malfunction.	Check resistance of the coils. Between blue and brown wire
			STG 7 = $\pm 310\Omega$ ; STG 5 = $\pm 310\Omega$
			Between blue and black wire
			STG 7 = $\pm 320\Omega$ ; STG 5 = $\pm 190\Omega$
	Between brown and black wire		
	STG 7 = $\pm 630\Omega$ ; STG 5 = $\pm 500\Omega$		
	Blower runs after starting it up by hand	Capacitor malfunction.	Check capacitor (see capacitor) or connect new capacitor.
	Blower stops during process and comes in again after a period of time	Coil overheated, thermistor switches off ( $150^{\circ}\text{C}$ – $302^{\circ}\text{F}$ ).	Check cooling circuit of blower. Check if rotisserie is close to another heat source. Measure temperature blower during process.
Temperature increases very fast ( $180^{\circ}\text{C}$ - $355^{\circ}\text{F}$ within 5 minutes)	Blower doesn't turn and heat stays in top of cavity.	Check the wiring. Check the power on the blower.	
Fuse F1 or F2 burned	Short circuit in coil to earth.	Check insulation value of coil with a Megger on 500V. Minimum value is 0.5 M $\Omega$ .	
<b>Blower TG 110</b>	Blower doesn't run	Wiring.	Check the wiring.
			Check the power on the blower.
	Blower stops during process and comes in again after a period of time	Coil malfunction.	Check resistance of the coils. Between the 2 black wires = $\pm 115\Omega$ .
			Check cooling circuit of blower.
			Check if rotisserie is close to another heat source. Measure temperature blower during process.
	Temperature increases very fast ( $180^{\circ}\text{C}$ - $355^{\circ}\text{F}$ within 5 minutes)	Blower doesn't turn and heat stays in top of cavity	Check the wiring. Check the power on the blower.
	Fuse F1 or F2 burned	Short circuit in coil to earth	Check insulation value of coil with a Megger on 500V. Minimum value is 0.5 M $\Omega$ .

**SERVICING AND REPAIRING OF THE TG50 M**

Description of part	Symptoms	Possible causes	Solving: checking/action
<b>Door</b>	Broken glass	Slamming of door.	Give instruction to operator.
		Fastening bolts and nuts are loose.	Tighten all fastenings.
	Door adjustment	Door not well adjusted and closes against bottom side.	Adjust door on hinge and tighten the hinge plate.
<b>Heating element</b>	Rotisserie doesn't reach adjusted temperature	Wiring.	Check the wiring.
			Check the power on the element.
		Element malfunction.	Check the current with AC current tester. See table on page 24.
	Duration of grilling time is too long	Wiring.	Check the wiring.
Element malfunction.		Check the current with AC current tester. See table on page 24.	
<b>Thermostat</b>	Oven temperature differs from temperature setting	Wiring.	Check the wiring.
		Thermostat malfunction.	Check if the thermostat is making contact.
		Thermostat probe not in right position.	Check the position of the thermostat probe.
<b>Main switch</b>	No power to all, or some oven controls	Wiring.	Check the wiring on the switch.
		Malfunction of the cams on the switch.	Check the cams.
		Contacts burned.	Check the contacts on the switch.
<b>Timer</b>	No functions of oven are working	Wiring.	Check the wiring on the switch.
			Malfunction of the timer.
	Grilling process is working, but doesn't stop	Malfunction of the timer.	Check if the time is running down on timer (does it tick).
Check if the timer switches off after reaching the zero position.			

Description of part	Symptoms	Possible causes	Solving: checking/action
<b>Capacitor</b>	Drive motor doesn't work	Wiring.	Check the wiring.
		Capacitor malfunction.	<p>Check function after connecting a new capacitor. Checking of capacitor: Discharge capacitor with screwdriver. Set meter on <math>M\Omega</math> and connect the pins of the meter on contacts, value runs up. Change the pins on contacts, value runs up again. This means the capacitor is OK.</p> <p>Another test is to charge the capacitor with a Megger on 250V and first check the insulation value. Wait for a minute and discharge the capacitor with a screw driver. When it still flashes it means the capacitor is OK.</p>
<b>Drive motor</b>	Motor doesn't run	Wiring.	Check the wiring.
			Check the power to the motor.
		Coil malfunction	<p>Check resistance of the coils. Between whiteA and white wire <math>\pm \dots\Omega</math> Between whiteA and black wire <math>\pm \dots\Omega</math> Between white and black wire <math>\pm \dots\Omega</math></p>
		Reduction gearbox.	Check if reduction gearbox is blocked.
	Motor runs after starting it up by hand	Capacitor malfunction.	Check capacitor (see capacitor) or connect new capacitor.
	Motor stops during process and comes in again after a period of time	Coil overheated, thermistor switches off ( $105^{\circ}\text{C} - 221^{\circ}\text{F}$ ).	<p>Check cooling circuit of motor.</p> <p>Check if rotisserie is close to another heat source.</p> <p>Measure temperature motor during process.</p>
	Main fuse burned	Short circuit in coil to earth.	Check insulation value of coil with Megger on 500V. Minimum value is $0.5\text{ M}\Omega$ .



Description of part	Symptoms	Possible causes	Solving: checking/action
<b>Blower</b>	Blower doesn't run	Wiring.	Check the wiring.
		Check the power on the blower.	
	Coil malfunction.	Check resistance of the coils. Between the 2 black wires = $\pm 115 \Omega$ .	
	Blower stops during process and comes in again after a period of time	Coil overheated, thermistor switches off ( $150^{\circ}\text{C}$ – $302^{\circ}\text{F}$ ).	Check cooling circuit of blower.
			Check if rotisserie is close to another heat source.
	Measure temperature blower during process.		
Temperature runs up very fast ( $180^{\circ}\text{C}$ - $355^{\circ}\text{F}$ within 5 minutes)	Blower doesn't turn and heat stays in top of cavity.	Check the wiring.	
Check the power on the blower.			
Main fuse burned	Short circuit in coil to earth.	Check insulation value of coil with a Megger on 500V. Minimum value is 0.5 M $\Omega$ .	

EXPLODED VIEWS & PARTLISTS

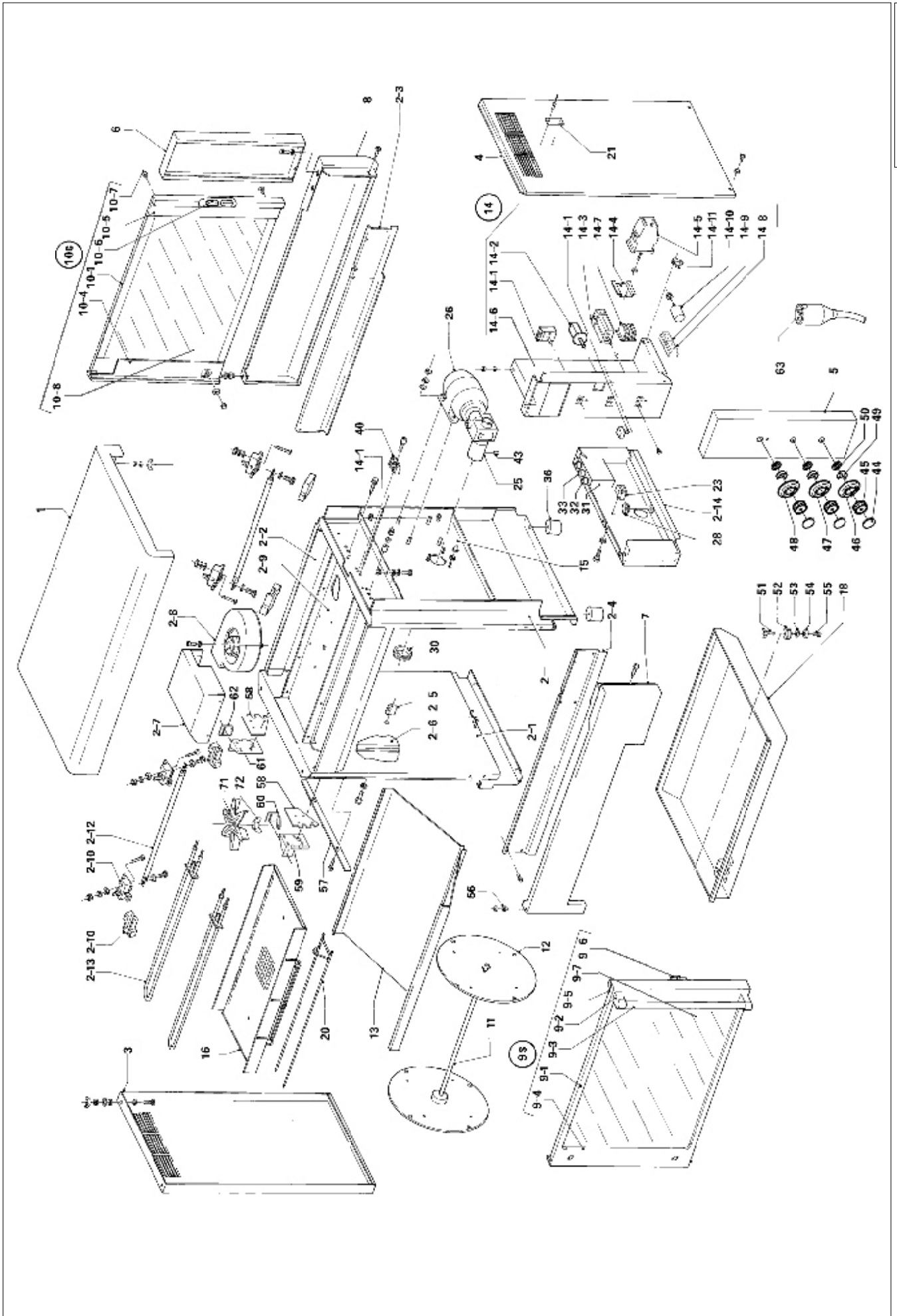

ITEM	QTY	PARTNUMBER	DESCRIPTION
10-8	1	9077054	Glass
11	1	9170571	Rotor shaft, incl. disc studs, stainless steel
12	2	9175000	Rotor disc 3 mm, stainless steel
13	2	9041142	Bottom plate
14	1	9046373	Electric panel, ass.
14-1	2	9070531	Thermostat 50-250 °C
14-2	1	9040463	Timer, 120 min.
14-3	1	9172056	Main switch
14-4	1	9077088	Bracket, magnetic switch
14-5	1	9077070	Contact
14-6	1	9045324	Mounting plate, electrical components
14-7	1	9040374	Connecting block
14-8	1	9044564	Connecting block, 1,2,3
14-9	1	9044572	Connecting block, 4,5,6
14-10	1	9077101	Capacitor 2,5 mF
14-11	1	0166555	Earth symbol
15	1	9045073	Mounting plate, gear motor
16	1	9045188	Plate, air guide
18	1	9044815	Drawer
20	4	9010549	Meatfork, stainless steel
21	1	9123467	Indication plate
23	1	9050426	Strain relief
25	1	9070206	Drive head
26	1	9070565	Gearmotor
28	1	9070840	Grommet
30	1	9073131	Sealing ring
31	1	9074500	Fuse-bracket
32	3	9044205	Fuse holder
33	3	9110250	Fuse SC10, 10A
36	4	9082910	Leg,adjustable
40	1	0166505	Connection block
41	3	9040099	Control knob
43	1	9008233	Screw, adjusting
44	3	9172050	Cover, knob
45	3	9172022	Control knob, black

TG110M - ASSEMBLY			
ITEM	QTY	PARTNUMBER	DESCRIPTION
1	1	9045007	Cap, top
2	1	9045023	Side panel, right
2-1	1	9045015	Side panel, left
2-2	1	9045081	Ceiling
2-3	1	9041184	Reinforcement, customer side
2-4	1	9041192	Reinforcement, service side
2-5	1	9070167	Steel bearing, 12 mm
2-6	1	9041312	Reinforcement, bearing
2-7	1	9041354	Air deflector
2-8	1	9070581	Blower
2-9	1	9045065	Fan plate
2-10	4	9110023	Lamp holder, cap + housing
2-12	2	9056082	Quartz light, 1000 W
2-13	2	9040625	Heating element 208 V, 1500 W
2-14	1	9041362	Mounting plate
3	1	9041012	Plate, outer, left
4	1	9041022	Plate, outer, right
5	1	9048048	Operation panel
6	1	9048267	Name panel
7	1	9045049	Front, under, service side
8	1	9045057	Front, under, customer side
9.5	1	9046030	Door service side, ass.
9-1	1	9048518	Doorframe
9-2	2	9040031	Holder, door handle
9-3	1	9040243	Door handle
9-4	1	9045099	Hinge pin, profile
9-5	1	9041053	Holder, magnet
9-6	8	9040081	Magnet block
9-7	1	9077054	Glass
10.C		9046020	Door customer side, ass.
10-1	1	9048518	Doorframe
10-4	1	9045099	Hinge pin, profile
10-5	1	9041053	Holder, magnet
10-6	8	9040081	Magnet block
10-7	2	9044378	Plug

ITEM	QTY	PARTNUMBER	DESCRIPTION
46	1	9172297	Back plate, main switch
47	1	9172296	Back plate, 120 min.
48	1	9172031	Back plate, 480° F
49	3	9172052	Locking ring, knob
50	3	9110802	Plug
51	1	4311047	Wingscrew
52	1	9070777	Brass seat
53	1	9073987	Washer
54	1	9070670	Gasket, Viton
55	1	9070688	Bolt, M8x12
56	2	0602072	Brass bearing, 6 mm
57	1	9041320	Mounting plate
58	2	9175097	Tap plate, hinge
59	1	9175094	Hinge plate, service side
60	1	9175096	Hinge, service side
61	1	9175150	Hinge plate, customer side
62	1	9175151	Hinge, customer side
63	1	9172403	Connecting cable with plug 15-20P
71	1	9110153	Fanblade
72	1	9073150	Wingnut, left hand threaded

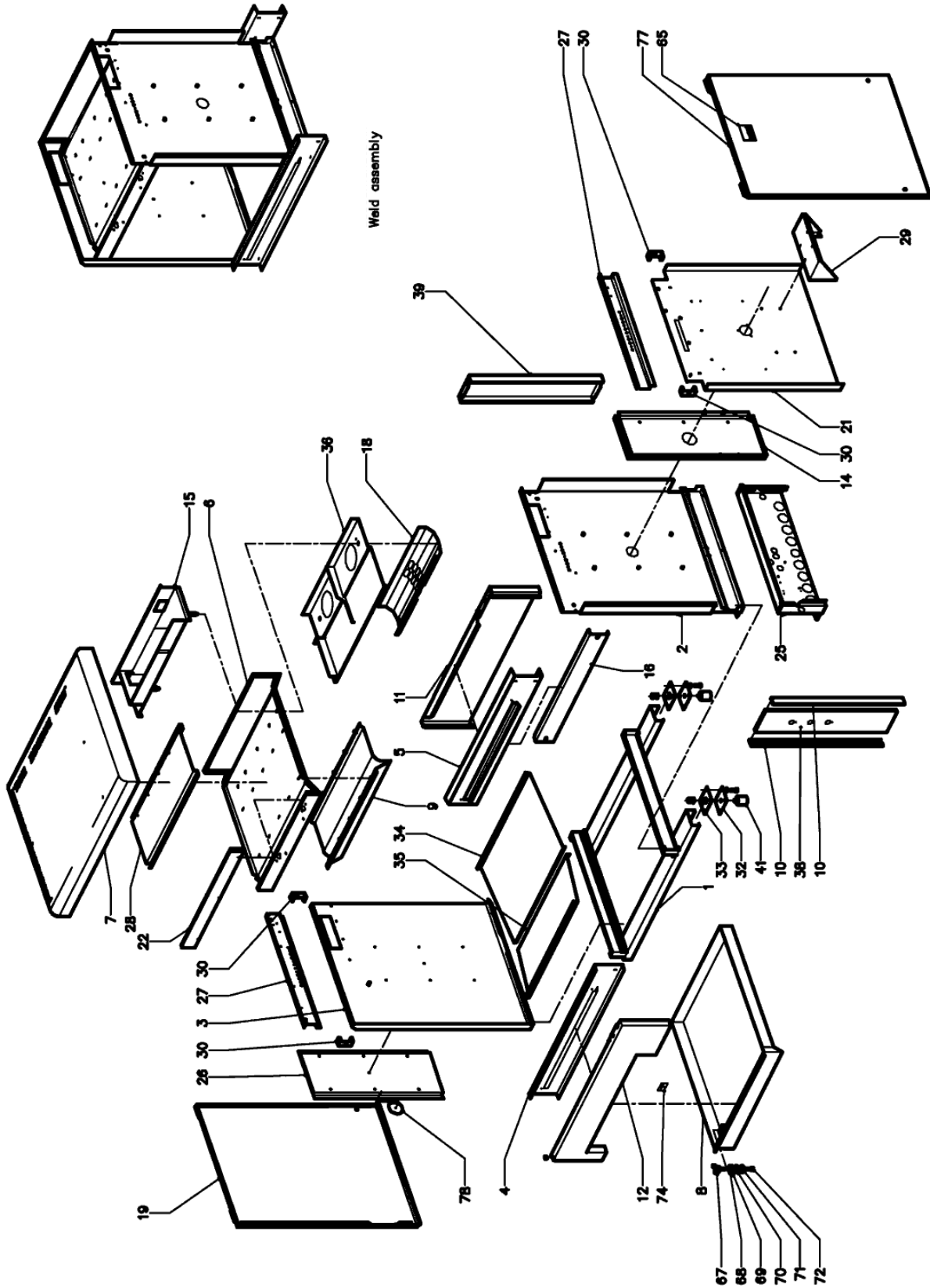

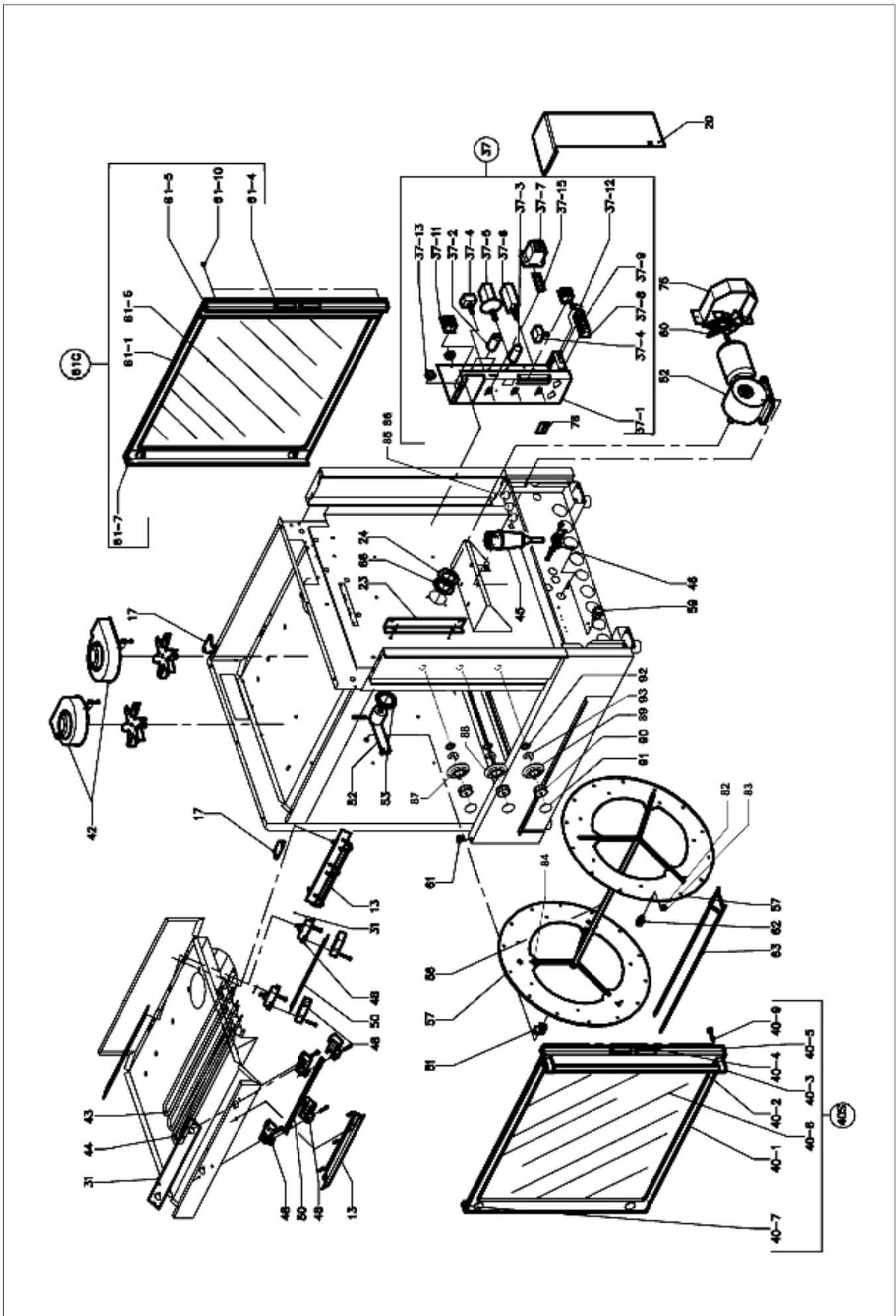

ITEM	QTY	PARTNUMBER	DESCRIPTION
68	1	9070777	Brass seat
69	1	9077004	Screw, adjusting
70	1	9073987	Washer
71	1	9070670	Gasket, Viton
72	1	9070688	Bolt, M8x12
74	1	9073351	Sticker, warning
77	1	9112406	Side panel, right
78	4	9112430	Washer, insulation support

TG330M - COMPONENTS			
ITEM	QTY	PARTNUMBER	DESCRIPTION
13	2	9116662	Protection, lamp
17	2	9111882	Hinge
20	1	9116785	Cover plate, electric components
23	1	9112074	Hinge (angle)
24	1	9112090	Washer, seal
31	2	9112210	Mounting plate, lamp holder
37	1	9118771	Electric panel, ass.
37-1	1	9116696	Mounting plate, electrical components
37-2	2	9110030	Capacitor 1,5 mF
37-3	1	9077101	Capacitor 2,5 mF
37-4	2	9070531	Thermostat 50-250 °C
37-5	1	9040463	Timer, 120 min.
37-6	1	9172056	Main switch
37-7	1	9077070	Contact
37-8	1	9044564	Connecting block, 1,2,3
37-9	1	9044572	Connecting block, 4,5,6
37-11	2	9040374	Connecting block
37-12	1	0166555	Earth symbol
37-13	2	9070840	Grommet
37-15	1	9077088	Bracket, magnetic switch
40.S	1	9046180	Door service side, ass.
40-1	1	9048550	Doorframe
40-2	1	9040251	Door handle
40-3	2	9040031	Holder, door handle
40-4	12	9040081	Magnet block

TG330M - SHEET IRON WORK			
ITEM	QTY	PARTNUMBER	DESCRIPTION
1	1	9116507	Base frame
2	1	9116515	Side panel, right
3	1	9116523	Side panel, left
4	1	9116531	Inner front, service side
5	1	9116549	Inner front, customer side
6	1	9111549	Ceiling
7	1	9116557	Cap, top
8	1	9116599	Drawer
9	1	9116612	Heat shield
10	2	9116620	Border
11	1	9116638	Border, customer side
12	1	9116646	Border, service side
14	1	9116670	Reinforcement, side plate, right
15	1	9116573	Mounting plate, blower
16	1	9111727	Sealing profile
18	1	9111913	Air guide plate
19	1	9111939	Side panel, left
21	1	9112016	Cover plate
22	1	9112058	Filling part
25	1	9112105	Mounting plate
26	1	9112121	Reinforcement, side plate
27	2	9112139	Side reinforcement
28	1	9112155	Reinforcement, ceiling
29	1	9112171	Support, gear motor
30	4	9112202	Reinforcement, hinge
32	4	9041778	Mounting plate, castor/leg
33	4	9042148	Mounting plate, leg
34	1	9111565	Driptray, large
35	1	9111604	Driptray, small
36	1	9116581	Cover plate, blower
38	1	9118021	Operation panel
39	1	9118135	Name panel
41	4	9011260	Leg, rubber
65	1	9123467	Indication plate
67	1	4311047	Wingscrew

ITEM	QTY	PARTNUMBER	DESCRIPTION
86	3	9110250	Fuse SC10, 10A
87	1	9172031	Back plate, 480° F
88	1	9172296	Back plate, 120 min.
89	1	9172297	Back plate, main switch
90	3	9172022	Control knob, black
91	3	9172050	Cover, knob
92	3	9110802	Plug, TG
93	3	9172052	Locking ring, knob

ITEM	QTY	PARTNUMBER	DESCRIPTION
40-5	1	9041590	Holder, magnet
40-6	1	9077062	Glass
40-7	1	9045162	Hinge pin, profile
40-9	2	4288319	Screw 6x20
42	2	9110048	Blower
43	2	9040633	Heating element 208 V, 2100 W
44	1	9110909	Heating element 208 V, 3100 W
45	1	9172405	Connecting cable with plug 1.5-50P
46	1	9050426	Strain relief
48	4	9110023	Lamp holder, cap + housing
50	2	9056082	Quartz light, 1000 W
51	1	9070175	Steel bearing, 14 mm
52	1	9116808	Gearmotor, complete with drive arm
53	1	9073131	Sealing ring
56	1	9070272	Rotor shaft, stainless steel
57	2	9174351	Rotor disc 3 mm, stainless steel
59	1	9070840	Grommet
60	1	2000072	Fanblade, motor
61	4	0602072	Brass bearing, 6 mm
62	14	9172169	Support pin, stainless steel
63	7	9070353	Meatfork, stainless steel
66	1	9110797	Sealring, drive bearing
75	1	9112375	Protection support
76	1	9112383	Bracket, timer
81.C	1	9046190	Door customer side, ass.
81-1	1	9048550	Doorframe
81-4	12	9040081	Magnet block
81-5	1	9041590	Holder, magnet
81-6	1	9077062	Glass
81-7	1	9045162	Hinge pin, profile
81-10	2	9044378	Plug
82	14	4312271	Nut M8, support pin, stainless steel
83	14	0142056	Spring washer M8, support pin, stainless steel
84	12	4288230	Tensilock bolt M5x10
85	3	9044205	Fuse holder



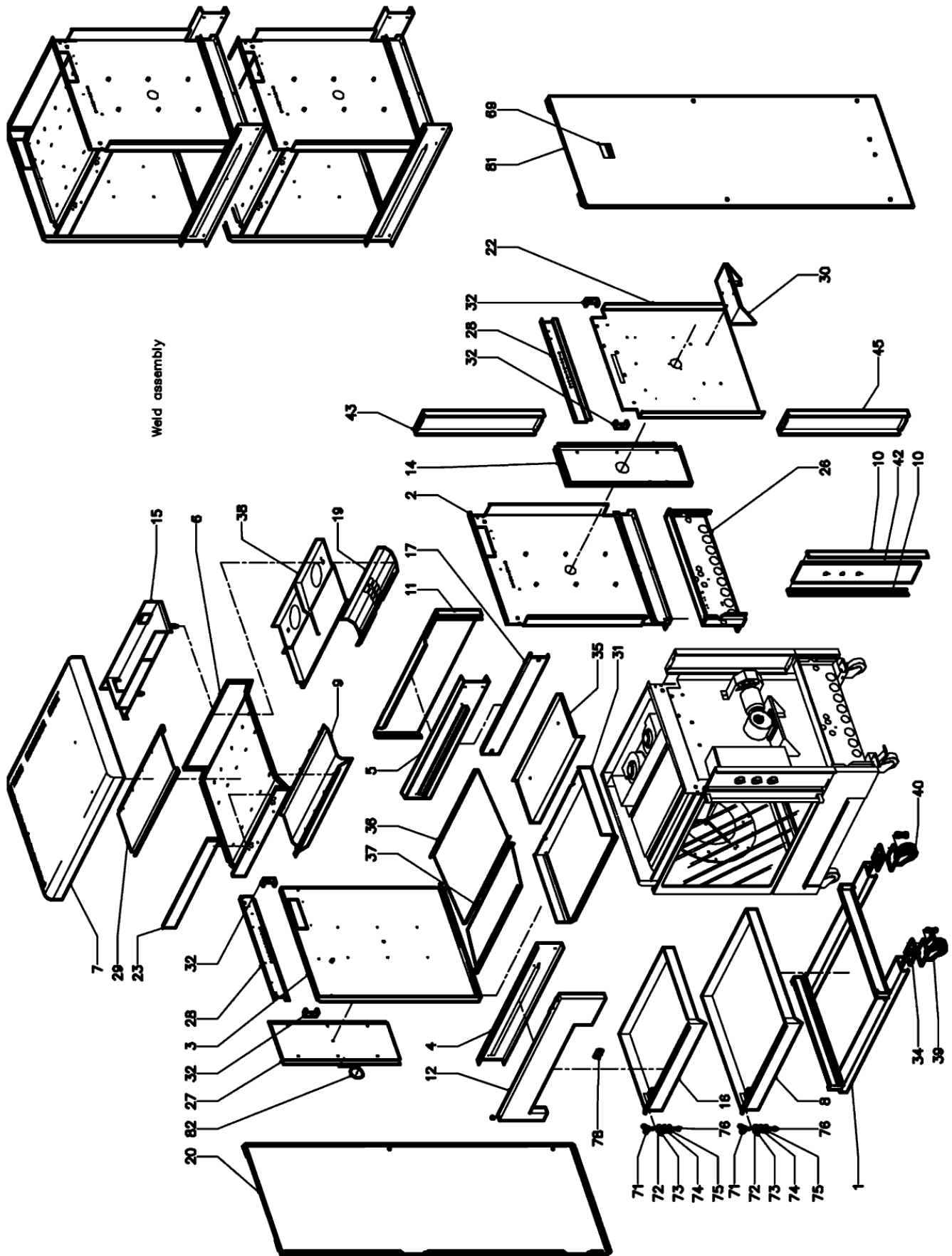

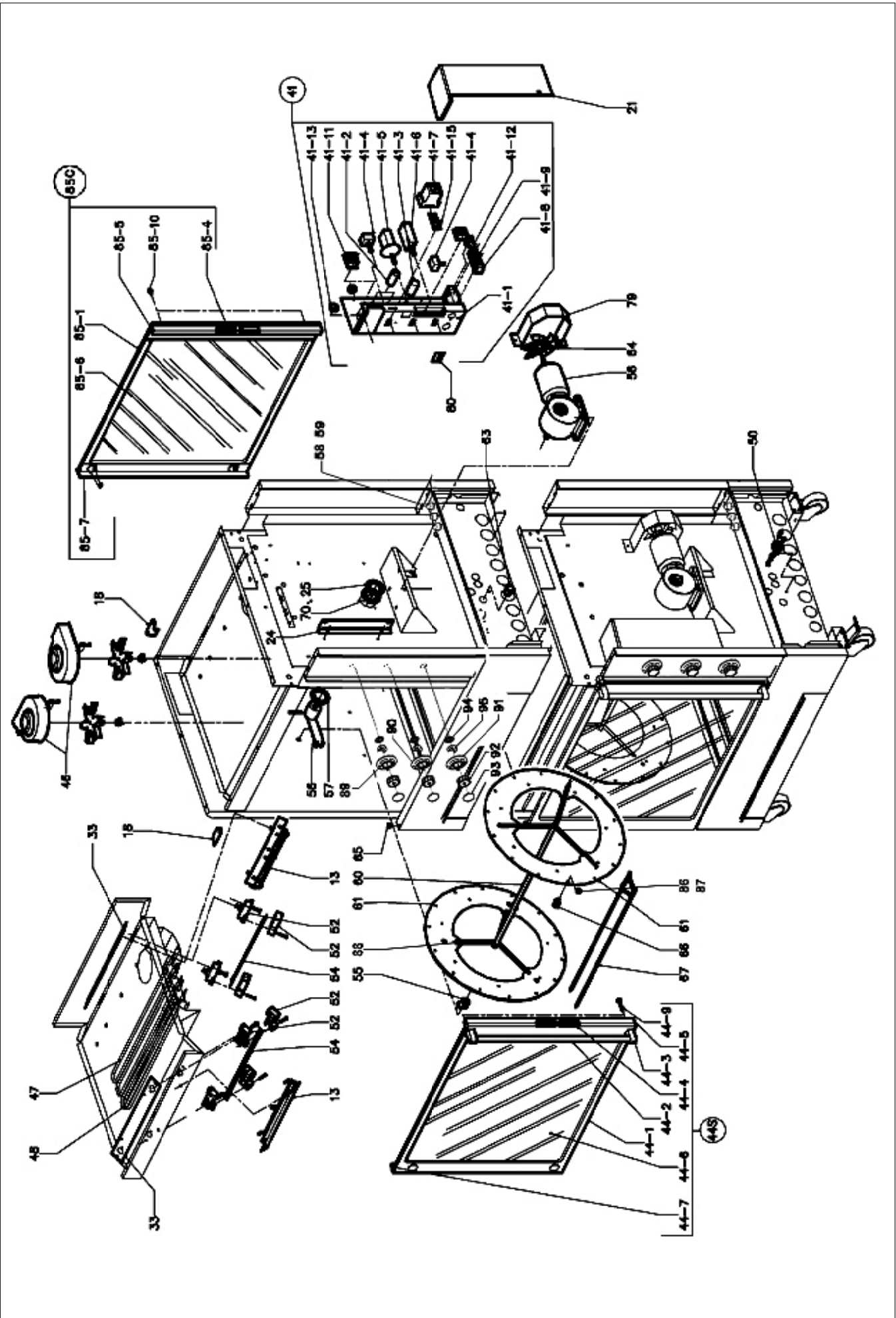

ITEM	QTY	PARTNUMBER	DESCRIPTION
43	1	9118135	Name panel
45	1	9118151	Panel, customer side
69	1	9123467	Indication plate
71	2	4311047	Wingscrew
72	2	9070777	Brass seat
73	2	9077004	Screw, adjusting
74	2	9073987	Washer
75	2	9070670	Gasket, Viton
76	2	9070688	Bolt, M8x12
78	1	9073351	Sticker, warning
81	1	9112391	Side panel, outer
82	8	9112430	Washer, insulation support

TG550M - COMPONENTS			
ITEM	QTY	PARTNUMBER	DESCRIPTION
13	4	9116662	Protection, lamp
18	4	9111882	Hinge
21	2	9116785	Cover plate, electric components
24	2	9112074	Hinge (angle)
25	2	9112090	Washer, seal
33	4	9112210	Mounting plate, lamp holder
41	2	9118771	Electric panel, ass.
41-1	2	9116696	Mounting plate, electrical components
41-2	4	9110030	Capacitor 1,5 mF
41-3	2	9077101	Capacitor 2,5 mF
41-4	4	9070531	Thermostat 50-250 °C
41-5	2	9040463	Timer, 120 min.
41-6	2	9172056	Main switch
41-7	2	9077070	Contacto
41-8	2	9044564	Connecting block, 1,2,3
41-9	2	9044572	Connecting block, 4,5,6
41-11	4	9040374	Connecting block
41-12	2	0166555	Earth symbol
41-13	2	9070840	Grommet
41-14	2	0054211	Strain relief
41-15	2	9077088	Bracket, magnetic switch

TG550M - SHEET IRON WORK			
ITEM	QTY	PARTNUMBER	DESCRIPTION
1	1	9116507	Base frame
2	2	9116515	Side panel, right
3	2	9116523	Side panel, left
4	2	9116531	Inner front, service side
5	2	9116549	Inner front, customer side
6	2	9111549	Ceiling
7	1	9116557	Cap, top
8	1	9116599	Drawer
9	2	9116612	Heat shield
10	4	9116620	Border
11	2	9116638	Border, customer side
12	2	9116646	Border, service side
14	2	9116670	Reinforcement, side plate, right
15	2	9116573	Mounting plate, blower
16	1	9116604	Drawer
17	2	9111727	Sealing profile
19	2	9111913	Air guide plate
20	1	9111921	Side panel, outer
22	2	9112016	Cover plate
23	1	9112058	Filling part
26	2	9112105	Mounting plate
27	2	9112121	Reinforcement, side plate
28	4	9112139	Side reinforcement
29	2	9112155	Reinforcement, ceiling
30	2	9112171	Support, gear motor
31	1	9116565	Separation plate
32	8	9112202	Reinforcement, hinge
34	4	9041778	Mounting plate, castor/leg
35	1	9116654	Cover plate, blower
36	2	9111565	Drip tray, large
37	2	9111604	Drip tray, small
38	2	9116581	Cover plate, blower
39	2	9011422	Castor with brake
40	2	9011430	Castor without brake
42	2	9118039	Operation panel

ITEM	QTY	PARTNUMBER	DESCRIPTION
85-7	2	9045162	Hinge pin, profile
85-10	4	9044378	Plug
86	28	4312271	Nut M8, support pin, stainless steel
87	28	0142056	Spring washer M8, support pin, stainless steel
88	24	4288230	Tensilock bolt M5x10
89	2	9172031	Back plate, 480° F
90	2	9172296	Back plate, 120 min.
91	2	9172297	Back plate, main switch
92	6	9172022	Control knob, black
93	6	9172050	Cover, knob
94	6	9110802	Plug, TG
95	6	9172052	Locking ring, knob

ITEM	QTY	PARTNUMBER	DESCRIPTION
44.5	2	9046180	Door service side, ass.
44-1	2	9048550	Doorframe
44-2	2	9040251	Door handle
44-3	4	9040031	Holder, door handle
44.4	24	9040081	Magnet block
44-5	2	9041590	Holder, magnet
44-6	2	9077062	Glass
44-7	2	9045162	Hinge pin, profile
44-9	4	4288319	Screw 6x20
46	4	9110048	Blower
47	5	9040633	Heating element 208 V, 2100 W
48	1	9110909	Heating element 208 V, 3100 W
50	2	9050426	Strain relief
52	8	9110023	Lamp holder, cap + housing
54	4	9056082	Quartz light, 1000 W
55	2	9070175	Steel bearing, 14 mm
56	2	9116808	Gearmotor, complete with drive arm
57	2	9073131	Sealing ring
58	6	9044205	Fuse holder
59	6	9110250	Fuse SC10, 10A
60	2	9070272	Rotor shaft, stainless steel
61	4	9174351	Rotor disc 3 mm, stainless steel
63	2	9070840	Grommet
64	2	2000072	Fanblade, motor
65	8	0602072	Brass bearing, 6 mm
66	28	9172169	Support pin, stainless steel
67	1	9070353	Meatfork, stainless steel
70	2	9110797	Sealing, drive bearing
79	2	9112375	Protection support
80	2	9112383	Bracket, timer
85.C	2	9046190	Door customer side, ass.
85-1	2	9048550	Doorframe
85-4	24	9040081	Magnet block
85-5	2	9041590	Holder, magnet
85-6	2	9077062	Glass

ELECTRICAL DIAGRAMS

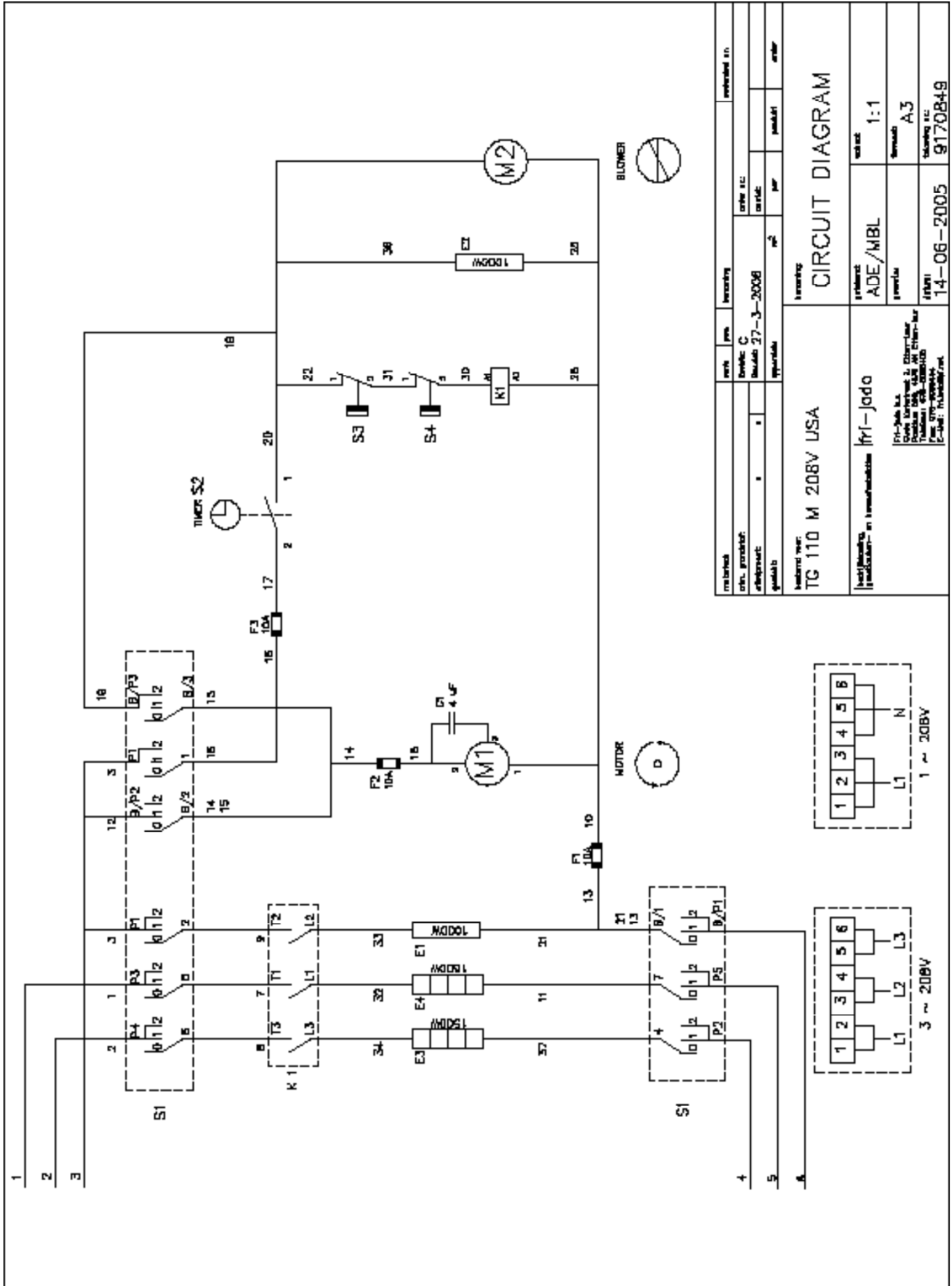

načrtovalec	verja	preverjalec	preverjeno št.
odobril	preverjen št.	preverjeno št.	preverjeno št.
skiciralec	skicirano št.	skicirano št.	skicirano št.
skicirano št.	skicirano št.	skicirano št.	skicirano št.
izdelano v: <b>TC 110 M 208V USA</b> izdelano v: <b>fri-jado</b> priporočila: <b>14-06-2005</b> skicirano št.: <b>9170B49</b>			
skicirano št.: <b>9170B49</b> izdelano v: <b>14-06-2005</b> skicirano št.: <b>9170B49</b>			

TG110M - Circuit Diagram

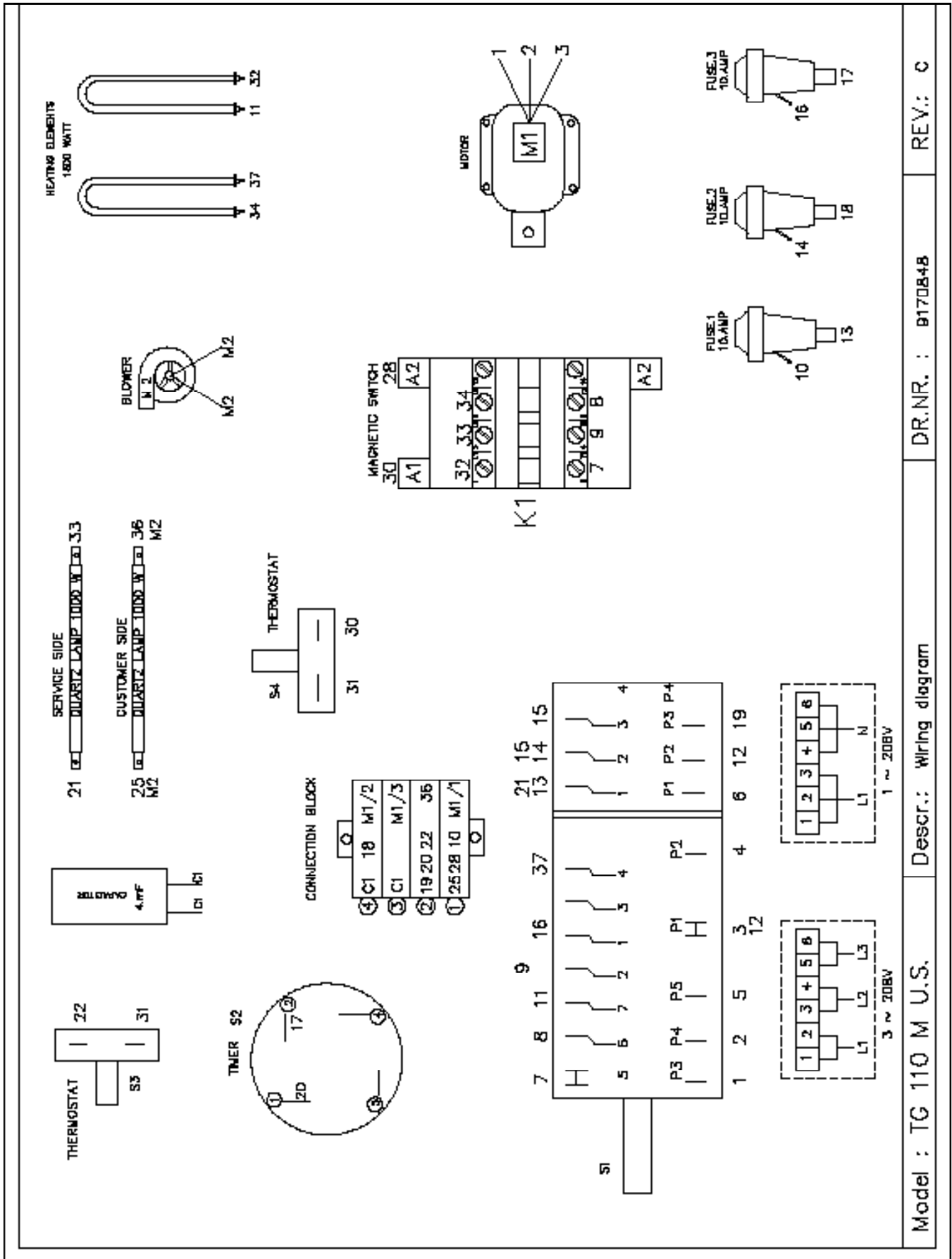

REV.: C

DR.NR. : 917084B

Descr.: Wiring diagram

Model : TG 110 M U.S.

TG110M - Wiring Diagram

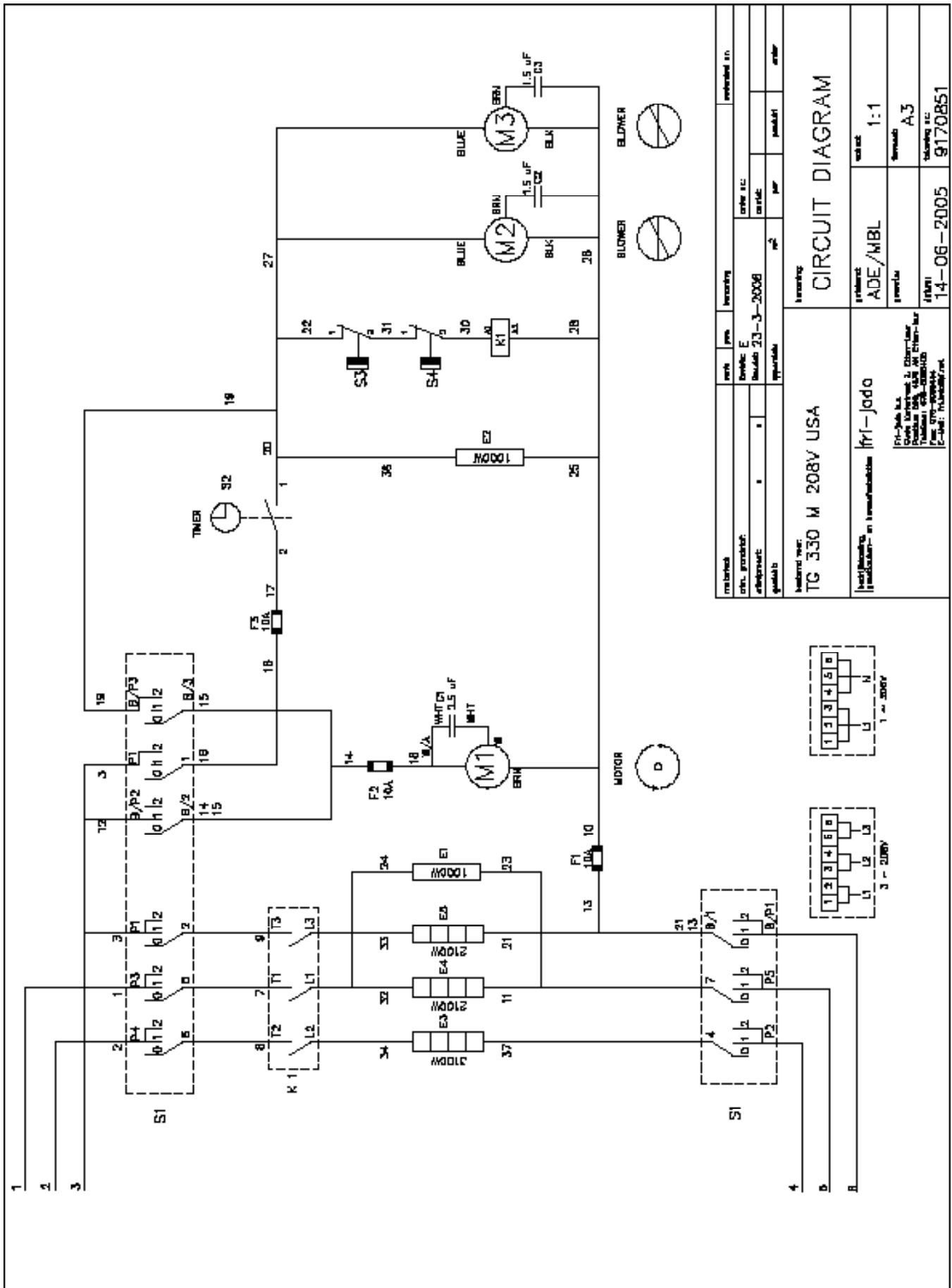

TG330M - Circuit Diagram

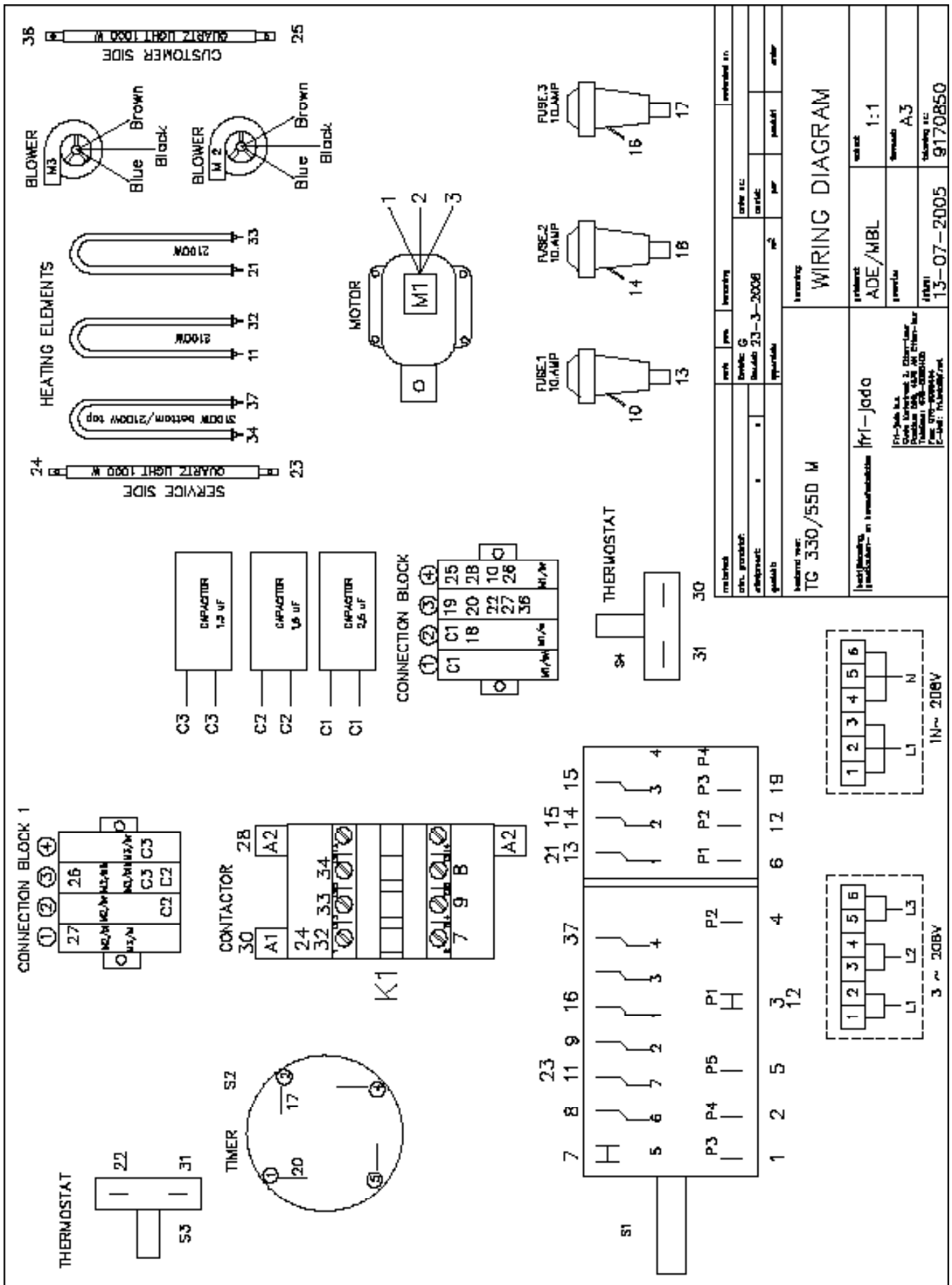

material		part		quantity		unit		reference no.	
des. product:		Dinco G		order ref.:		order ref.:			
reference:		Dinco 23-3-2006		partic:		partic:			
quantity:		1		partic:		partic:			
reference ref.:		TG 330/550 M		drawing:		drawing:			
manufacturer:		fri-jado		reference:		reference:			
reference:		ADE/MBL		scale:		scale:			
reference:		A3		drawing ref.:		drawing ref.:			
reference:		13-07-2005		drawing ref.:		drawing ref.:			
reference:		9170850		drawing ref.:		drawing ref.:			

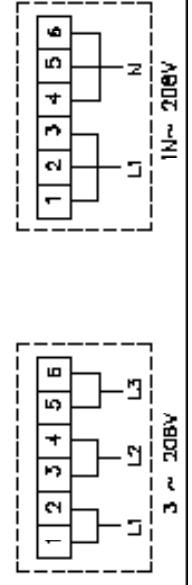

TG330M / TG550M - Wiring Diagram



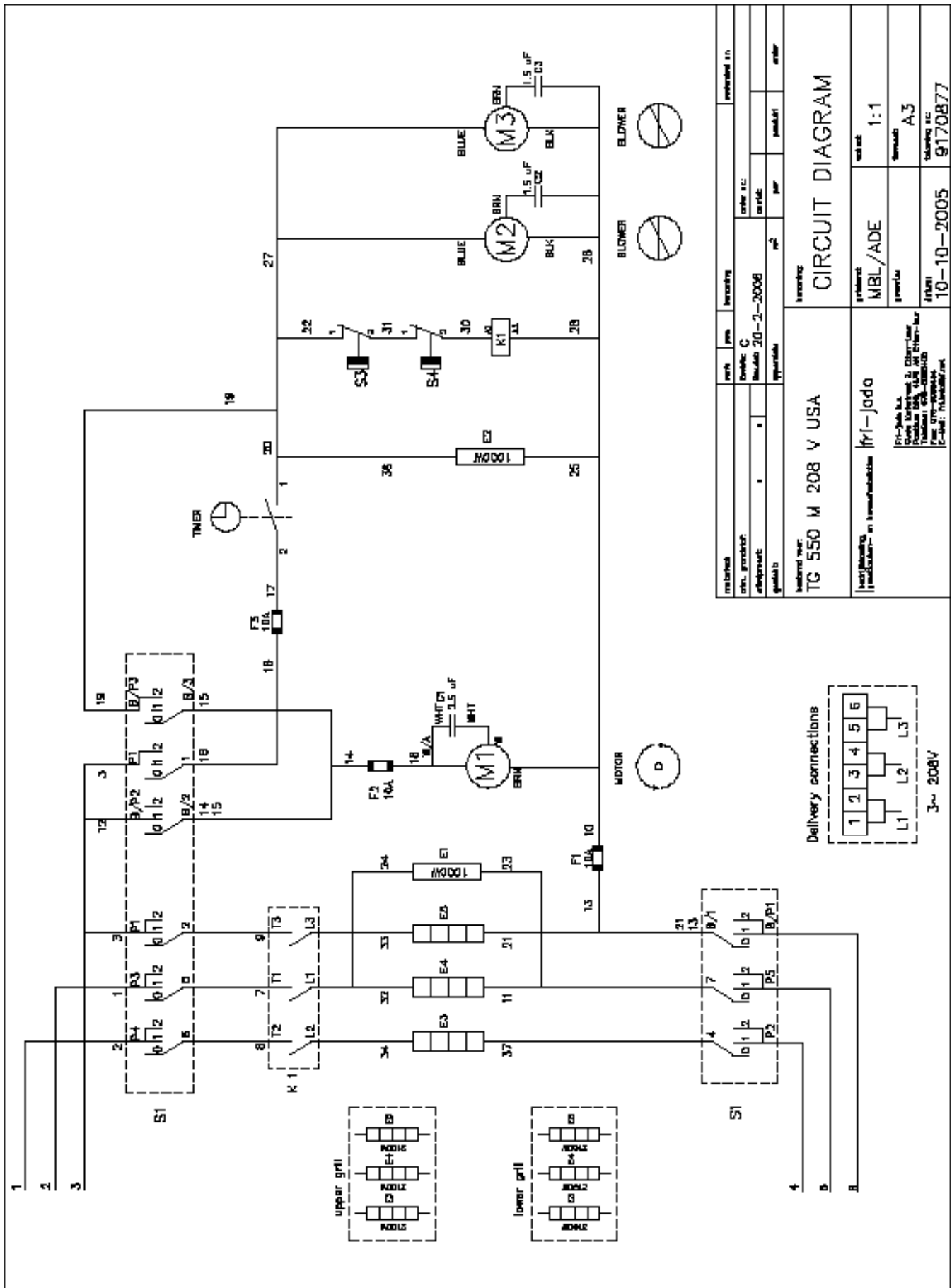

material		year	part	revision	revised in
ref. product		series C			series n.c.
equipment		model	20-2-2008		series
quantity		quantity	m <sup>2</sup>	per	product
<b>blower near</b> <b>TG 550 M 208 V USA</b> <b>fr-jado</b>					
<b>CIRCUIT DIAGRAM</b>					
<b>1:1</b>					
<b>A3</b>					
<b>10-10-2005</b>					
<b>9170877</b>					

TG550M - Circuit Diagram

---

EMPTY PAGE

