

1814E with FilterQuick™

Electric Fryer

Parts Manual

This manual is updated as new information and models are released. Visit our website for the latest manual.



Part Number: FRY_P_8197319 11/2016

NOTICE

IF, DURING THE WARRANTY PERIOD, THE CUSTOMER USES A PART FOR THIS MANITOWOC FOOD SERVICE EQUIPMENT OTHER THAN AN UNMODIFIED NEW OR RECYCLED PART PURCHASED DIRECTLY FROM FRYMASTER, OR ANY OF ITS FACTORY AUTHORIZED SERVICERS, AND/OR THE PART BEING USED IS MODIFIED FROM ITS ORIGINAL CONFIGURATION, THIS WARRANTY WILL BE VOID. FURTHER, FRYMASTER DEAN AND ITS AFFILIATES WILL NOT BE LIABLE FOR ANY CLAIMS, DAMAGES OR EXPENSES INCURRED BY THE CUSTOMER WHICH ARISE DIRECTLY OR INDIRECTLY, IN WHOLE OR IN PART, DUE TO THE INSTALLATION OF ANY MODIFIED PART AND/OR PART RECEIVED FROM AN UNAUTHORIZED SERVICER.

NOTICE

This appliance is intended for professional use only and is to be operated by qualified personnel only. A Factory Authorized Servicer (FAS) or other qualified professional should perform installation, maintenance, and repairs. Installation, maintenance, or repairs by unqualified personnel may void the manufacturer's warranty.

⚠ DANGER

Improper installation, adjustment, maintenance or service, and unauthorized alterations or modifications can cause property damage, injury, or death. Read the installation, operating, and service instructions thoroughly before installing or servicing this equipment.

⚠ DANGER

The front ledge of this appliance is not a step! Do not stand on the appliance. Serious injury can result from slips or contact with the hot oil.

⚠ WARNING

Do not attach accessories to this fryer unless fryer is secured from tipping. Personal injury may result.

⚠ DANGER

Adequate means must be provided to limit the movement of this appliance without depending on or transmitting stress to the electrical conduit. A restraint kit is provided with the fryer. If the restraint kit is missing contact your local KES.

⚠ DANGER

Prior to movement, testing, maintenance and any repair on your Frymaster fryer, disconnect all electrical power from the fryer.

1814E with FILTERQUICK™ SERIES ELECTRIC FRYERS PARTS

TABLE OF CONTENTS

CAUTIONARY STATEMENTS	i
CHAPTER 1: Parts List	
1.1 Accessories.....	1-1
1.1.1 1814E FilterQuick PCB/Controller Board Matrix.....	1-1
1.2 Doors, Sides, Tilt Housings, Top Caps, Casters and Other Exterior Components	1-2
1.3 Electronics and Wiring Components.....	1-3
1.3.1 Component Boxes	1-3
1.3.2 Contactor Boxes.....	1-4
1.3.3 Heating Element Assemblies and Associated Parts.....	1-5
1.3.3.1 Element Assemblies and Hardware.....	1-5
1.3.3.2 Element Tube Assemblies	1-6
1.3.4 Wiring.....	1-6
1.3.4.1 Contactor Box Wiring Assemblies 12-Pin Full Vat	1-6
1.3.4.2 Contactor Box Wiring Assemblies 6-Pin Left Element	1-7
1.3.4.3 Contactor Box Wiring Assemblies 9-Pin Right Element	1-7
1.3.4.4 Component Box to Filter Pump Harness	1-7
1.3.4.5 Main Wiring Harness	1-8
1.3.4.6 Interface Board to Controller Wiring Harness 15-Pin	1-8
1.3.4.7 Component Box, Filter Pump and Basket Lift Wiring Harnesses	1-9
1.3.4.8 Basket Lift Harness.....	1-9
1.4 Filtration System Components	1-10
1.4.1 Filter Pan and Associated Components.....	1-10
1.4.2 Filter Pump and Associated Components	1-11
1.5 Filtration Electronic Components.....	1-12
1.5.1 Manual Interface Board (MIB) Assembly.....	1-12
1.5.2 Automatic Intermittent Filtration (AIF) Board Assembly	1-12
1.6 Frypot Assemblies and Associated Parts.....	1-13
1.7 Auto Top-Off Pump Assembly	1-14
1.8 Oil Plumbing Components.....	1-15
1.8.1 Bulk Manifold and Accessories.....	1-15
1.8.2 Bulk Dispose Waste Valve	1-16
1.8.3 Bulk Connection	1-17
1.8.4 Oil Quality Sensor (OQS) and Associated Parts	1-17
1.9 Basket Lift Assembly and Associated Parts.....	1-18
1.10 Wiring Connectors, Pin Terminals and Power Cords	1-20
1.11 Fasteners.....	1-21
1.12 Wiring Diagram for Harness Part Numbers	1-22

1814E with FILTERQUICK™ SERIES ELECTRIC FRYERS

CHAPTER 1: PARTS LIST

1.1 Accessories

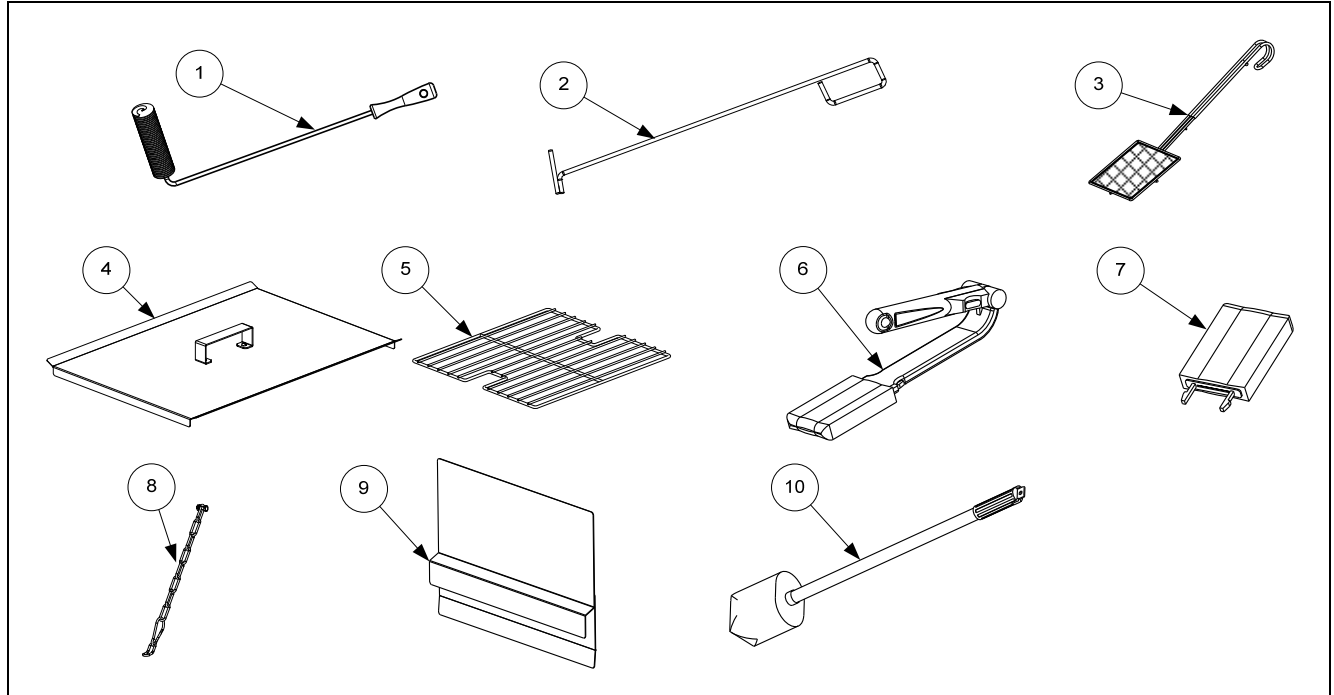

ITEM	PART #	COMPONENT
1	8030278	Brush, Frypot
2	8030388	Fryers Friend
3	8030446	Skimmer
4	1069620	Cover, Frypot 1817
5	8030380	Rack, Basket 1817
6	8030440	Fryer Scrubber Tool
7	8030439	Pad, Scrubber (For use with item #6)
8	8260900	Kit, Chain Restraint
9	8238155	Guard, Splash 1817
10	8030254	Brush, UHC (Oil Saddle Reservoir Cleaning Brush)
*	8030002	Powder, Filter (80- 1-Cup Applications)
*	8030170	Pack, 100-Sheet Filter Paper 27.5 X 19.5

* Not illustrated

1.1.1 1814E FilterQuick™ PCB/Controller Board Matrix

PART #	COMPONENT
1087002	Assembly, MIB PCB w/ metal work see section 1.5.1
1085721	Assembly, AIF Board w/ metal frame see section 1.5.2
1085717	Board, ATO PCB w/ software see section 1.3.1
8263301	FQ3000 Controller Generic see section 1.2
1087077	FQ3000 Controller Cracker Barrel see section 1.2

1.2 Doors, Sides, Tilt Housings, Top Caps, Casters and Other Exterior Components

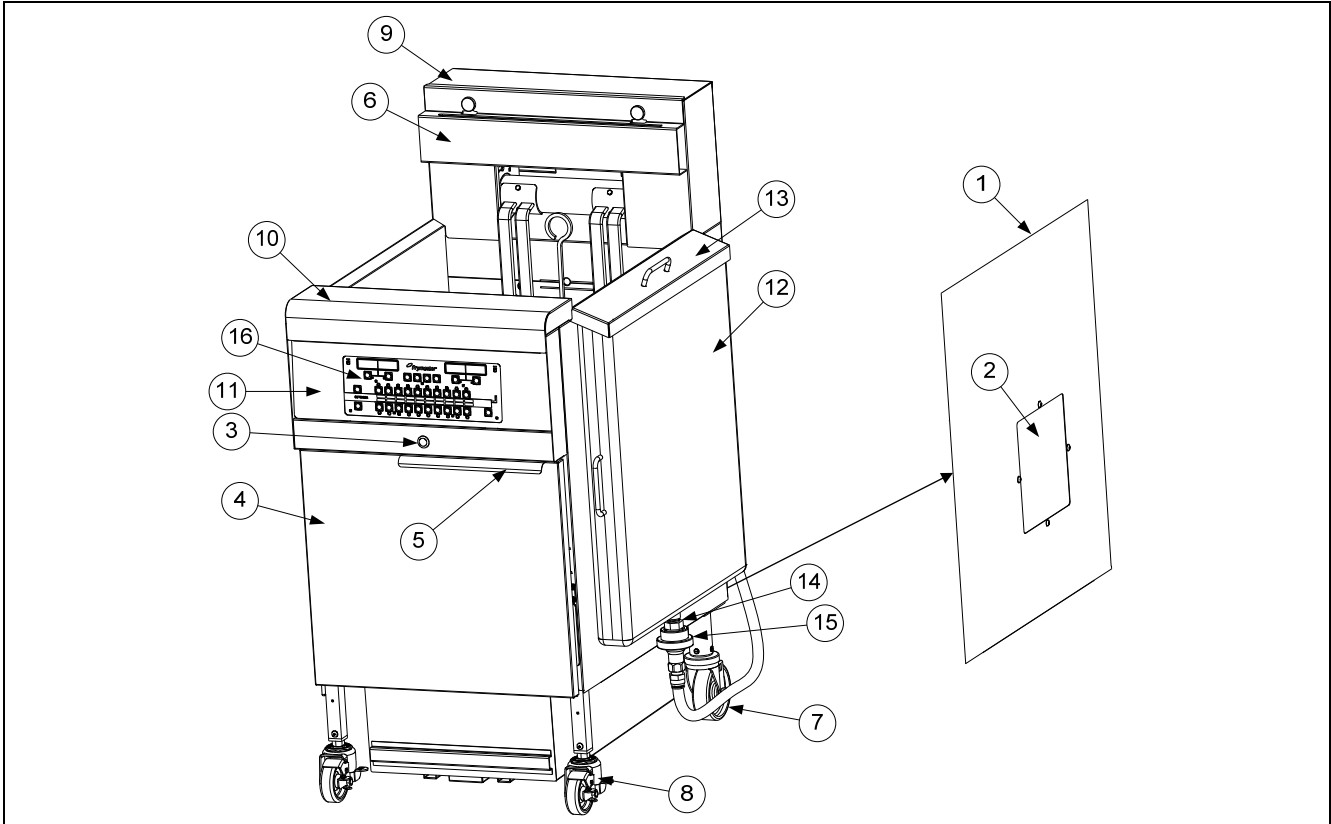

ITEM	PART #	COMPONENT
1	2601516	Side, Cabinet Left FQ1814 SS
*	2601517	Side, Cabinet Right FQ1814 SS
2	2601519	Cover, Cabinet Side Hole
√ 3	8075858	Switch, Push Button LED Blue Ring Light
4	1087031	Door, FQ1814 with Menu Holder
5	2108077	Handle, Door
*	1064067	Pin Assembly, Door
*	8100275	Spring, Door Pin
*	8100658	Retaining Ring
*	8121328	Hinge, Door Lower
*	2401407	Holder, 1814 Manual
*	8101105	Magnet, Door (vertical)
6	2304318	Hanger, Basket Single 1817
7	8100327	Caster 4" without Brake -Rear
8	8232844	Caster 3" with Brake -Front
9	8236716	Tilt Housing
10	1081722	Top Cap
11	2601520	Bezel, Controller FQ1814
12	8239210	Tank, Oil Saddle FQ1814
13	8239211	Lid, Oil Saddle Tank FQ1814
14	8130022	Nipple, 1/2" x Close NPT
15	8100490	Quick Disconnect 1/2" Female
√ 16	8263301	Controller, Replacement FilterQuick™
√	1087077	Controller, Replacement FilterQuick™ Cracker Barrel
*	2204317	Back, Lower Cabinet
*	2401464	Back, Upper Cabinet

* Not illustrated

√ Recommended parts

1.3 Electronics and Wiring Components

1.3.1 Component Boxes

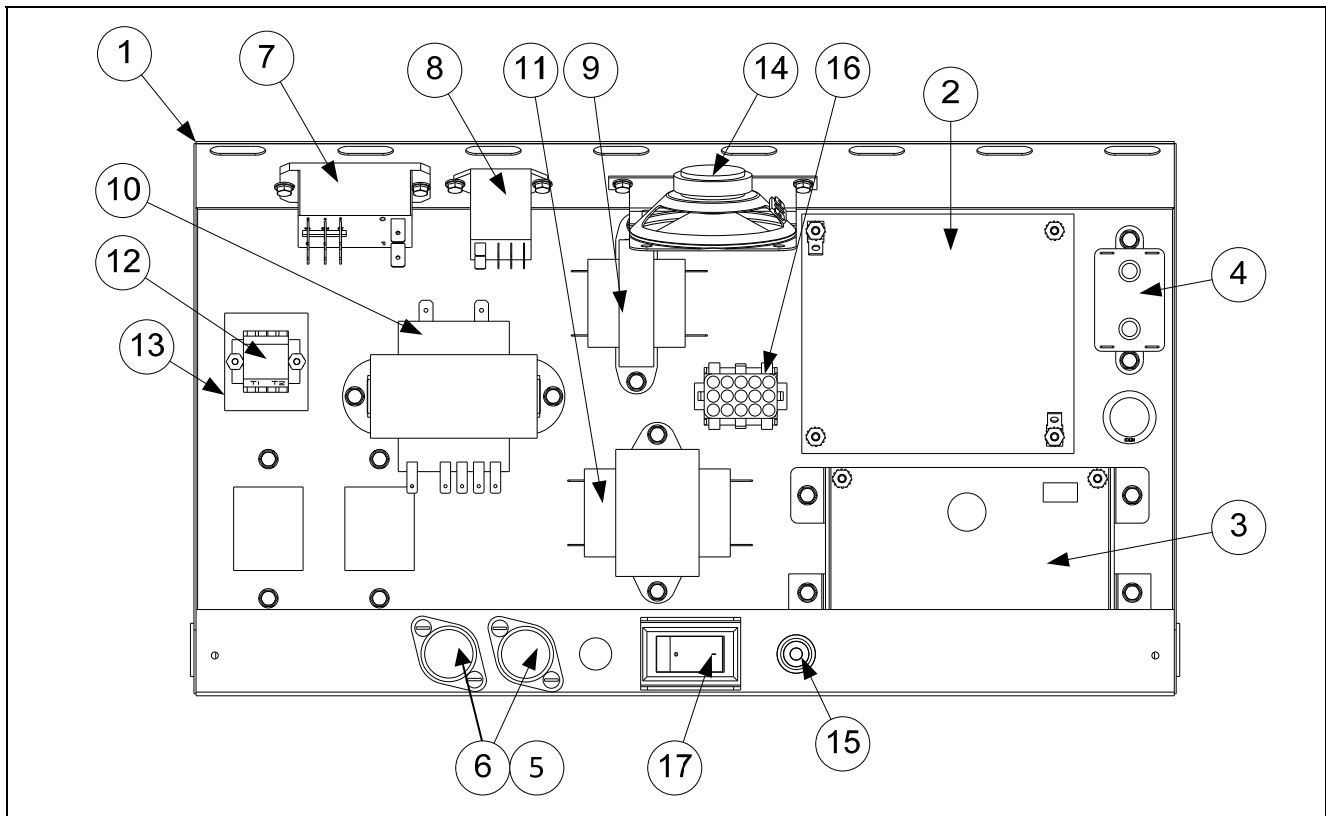

ITEM	PART #	COMPONENT
	1087001	Box Assembly, Component 208-240V
1	1086997	Box Stud Assembly, Component
√ 2	8262260	Interface Board, Standard Full or Dual Vat (includes sound harness)
√ 3	1085717	PCB Board, Automatic Top Off
√ 4	8070012	Relay, 18AMP 1/3 HP 24V Coil (Top off pump)
√ 5	8071321	Holder, AGC Panel Mount ¼" Fuse
√ 6	8072278	Fuse, 20 AMP
√ 7	8074482	Relay, Filter 2 Pole 30A DPDT 24VDC
8	8075623	Relay, 24VDC SPDT
√ 9	8070979	Transformer, 208-240V/12V 43VA Controller and ATO Board Power
√ 10	8075362	Transformer, 115-240V/24V 80VA MIB, AIF and ATO Pump
√ 11	8070680	Transformer, 208/240V/24V 20VA Heat/Latch Contactor, ATO board
12	8101164	Terminal Block
13	8160217	Paper, Insulating Terminal Block
14	8074403	Speaker, 4-Watt SMT
√ 15	8074678	Switch, Momentary Flush JIB Reset
16	1065750	Harness Assembly, RE FV Controls
√ 17	8074036	Switch, Power
*	8262249	RE Hood/Ansul Interlock Kit (includes terminal block, wires and connectors)

* Not illustrated

√ Recommended parts

1.3.2 Contactor Box

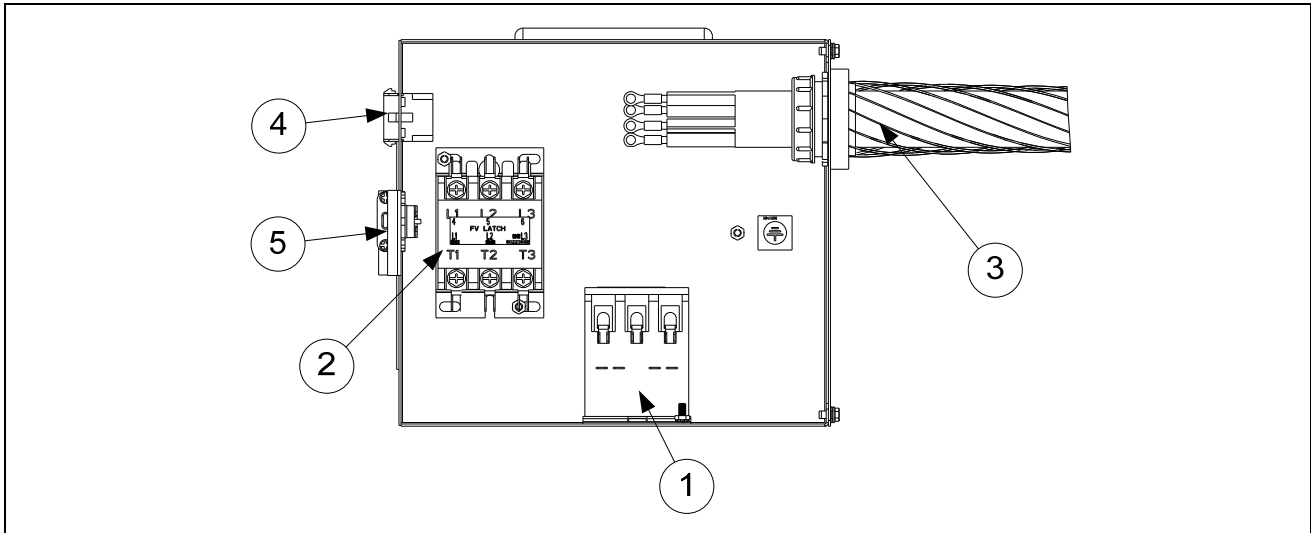

ITEM	PART #	COMPONENT
	1086999	Box, Contactor Assembly 1814FQ Delta
√ 1	8072284	Contactor, 24V Coil 50 Amp Mechanical (Heat)
√ 2	8101202	Contactor, 24V 40 Amp Mechanical (Latch)
3	8075625	Cord Set, 4 Gauge, 4 Wire with Strain Relief
4	1066031	Harness Assembly, RE FV Contactor Box Control
5	1080158	Harness Assembly, 208/240V Contactor Box Power
*	1068932	Bracket Assembly, Element Mounting
*	2401440	Cover, Contactor Box

* Not illustrated

√ Recommended parts

1.3.3 Heating Element Assemblies and Associated Parts

1.3.3.1 Element Assemblies and Hardware

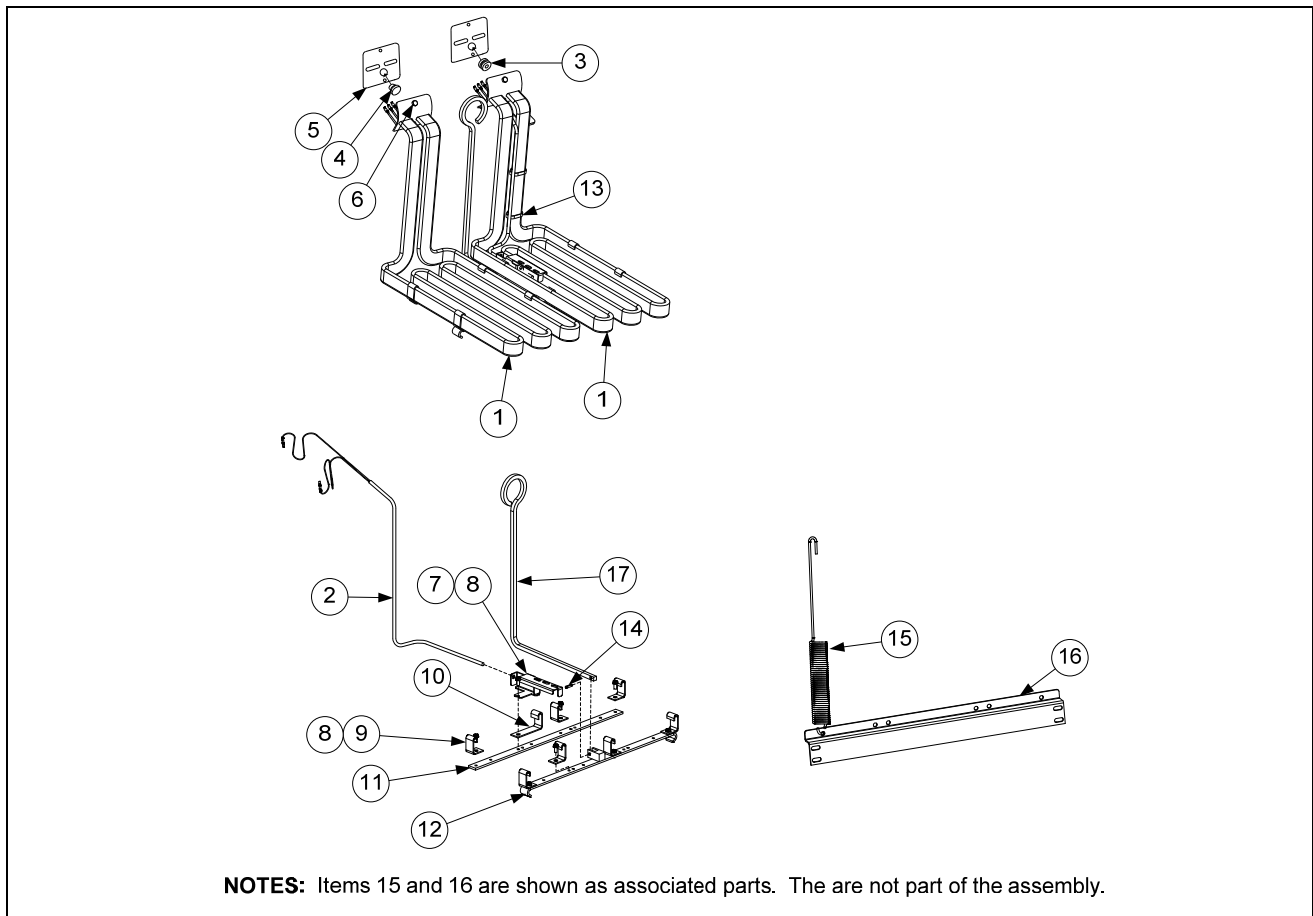

NOTES: Items 15 and 16 are shown as associated parts. They are not part of the assembly.

ITEM	PART #	COMPONENT
1		Element Kits – includes gaskets, grommets, tie wraps, screws and nuts.
	8262557	208V 8.5 kW
	8262707	230V 8.5 kW
	8262558	240V 8.5kW
√ 2	8262652	Probe, Temperature RE1817, 1814 – includes tie wraps and grommet.
3	8160681	Grommet, Probe
4	8160480	Plug, .375-inch Dome
5	8160688	Gasket, Element
6	8091003	Screw, 10-32 X 3/8-inch Hex Head SS
*	8090766	Nut, 10-32 Keps Hex Head SS
*	2304028	Wrench, Element Tube Nut Spanner
7	2300784	Bracket, Temperature Probe 8.5 kW (17kW)
8	8090518	Screw, 8-32 X 3/8-inch Slotted Hex Head
9	9102042	Clamp, Element (Short)
10	2300781	Clamp, Element (Long)
11	2304902	Support, Full-Vat Element Rear
12	8236711	Bracket, Element 1814
13	8090567	Tie-Wrap, Metal
14	8101212	Pin, .125 X .50-inch Slotted
15	8103030	Spring, Element Lift Left
	8103031	Spring, Element Lift Right
16	2204302	Bracket, Lower Spring
17	8101233	Handle, Element Lift

√ Recommended parts

1.3.3.2 Element Tube Assemblies

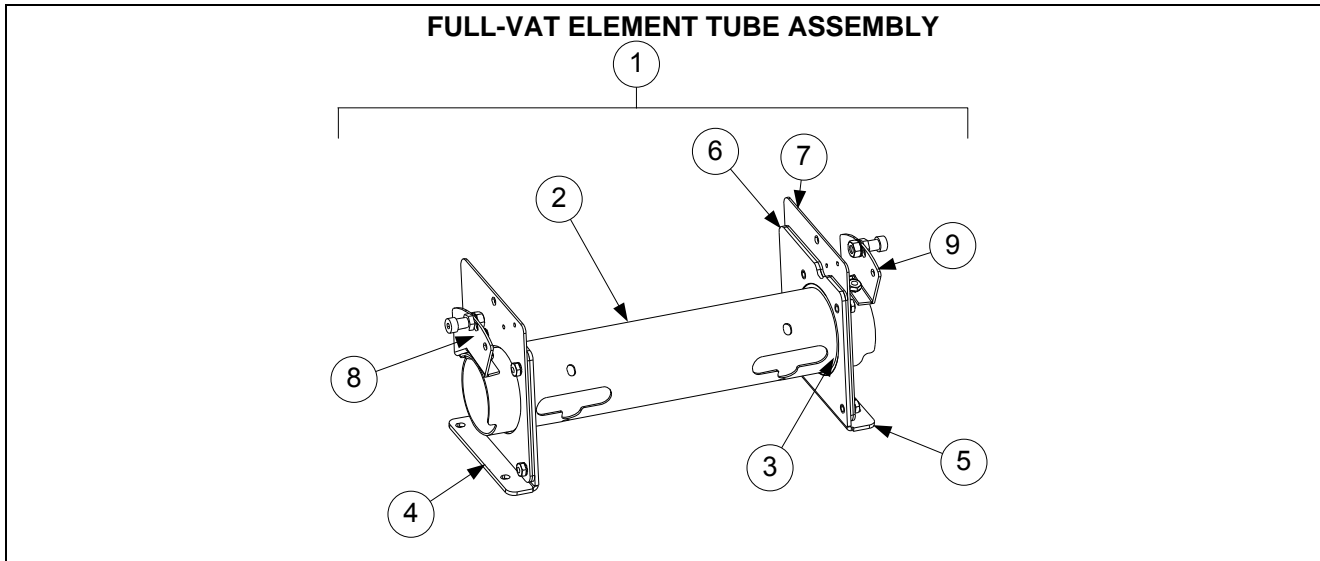

ITEM	PART #	COMPONENT
1	1080293	Tube Assembly, Full-Vat 17 kW
2	8102992	Tube, Full Vat Element Mounting
3	8102993	Bushing, Tube End Teflon
4	1080315	Bracket Assembly, LH Element Tube Support
5	1080316	Bracket Assembly, RH Element Tube Support
6	2200122	Plate, Element Tube Support Inner
7	2200123	Plate, Element Tube Support Outer
8	1066569	Bracket Assembly, LH Upper Spring
9	1066570	Bracket Assembly, RH Upper Spring
*	8262598	Kit, Tilt Switch
*	8074742	Switch, Long Lever High Temp

* Not illustrated

1.3.4 Wiring

1.3.4.1 Contactor Box Wiring Assemblies – 12-Pin Full-Vat C-1

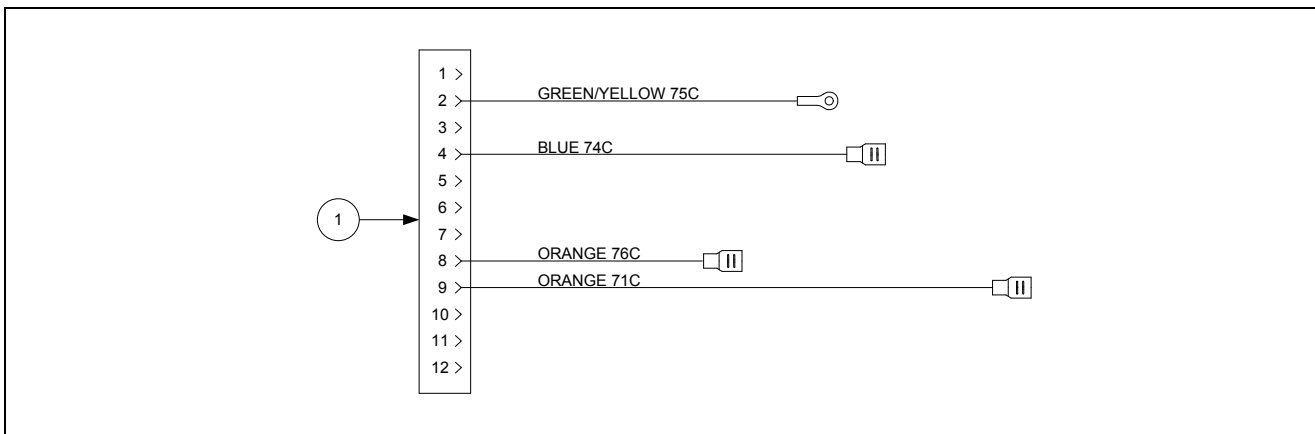

ITEM	PART #	COMPONENT
1	1066031SP	Contactor Box Harness Assembly Full Vat Standard

1.3.4.2 Contactor Box Wiring Assembly – 6-Pin (Left Element)

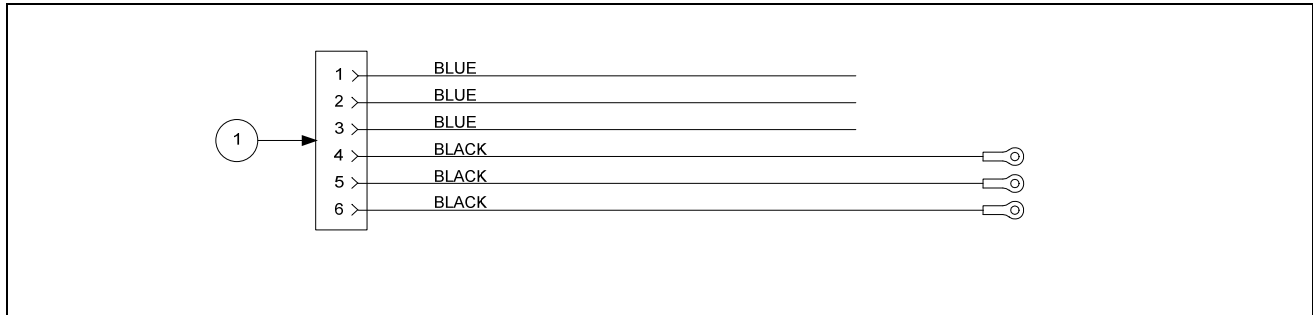

ITEM	PART #	COMPONENT
1	1068744SP	14/17 kW Mechanical Contactor

1.3.4.3 Contactor Box Wiring Assembly – 9-Pin (Right Element)

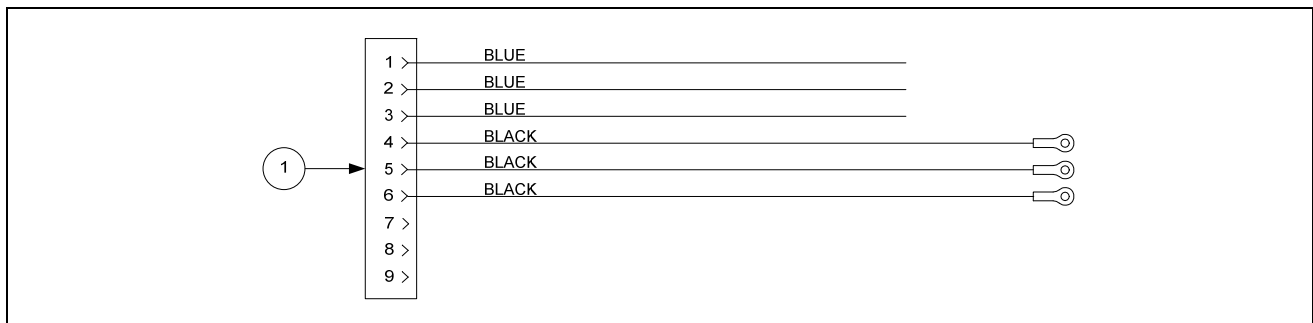

ITEM	PART #	COMPONENT
1	1068745SP	14/17 kW Mechanical Contactor

1.3.4.4 Component Box to Filter Pump Harness

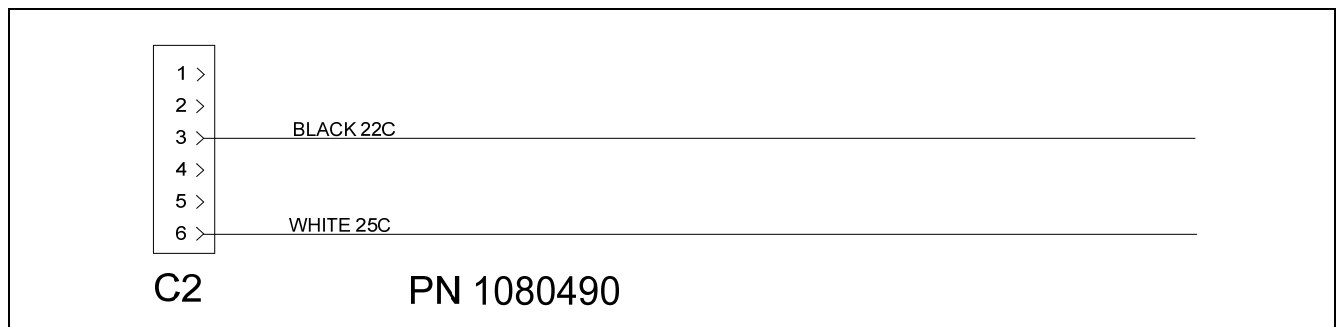

1.3.4.5 Main Wiring Harness

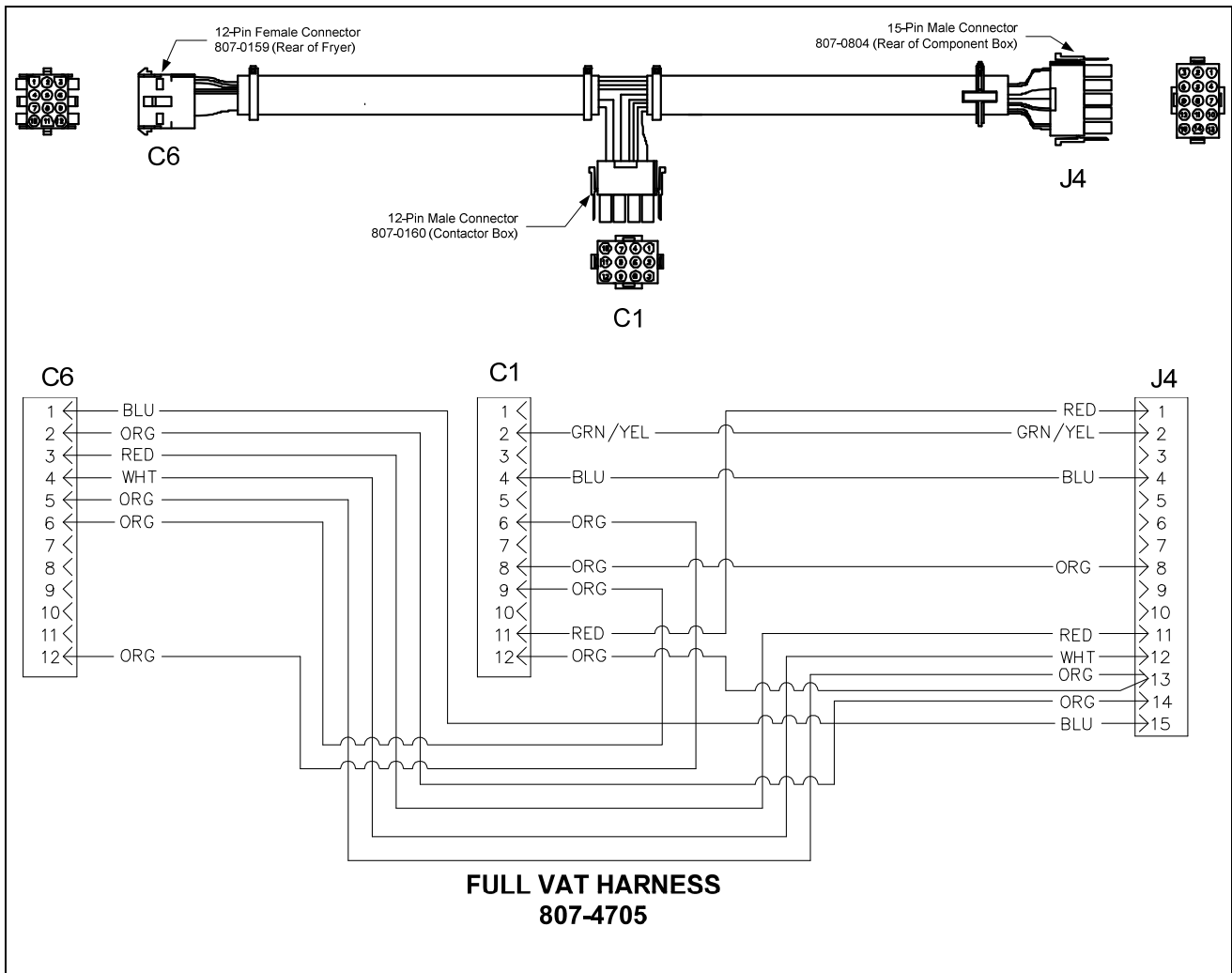

1.3.4.6 Interface Board to Controller Wiring Harness – 15-Pin

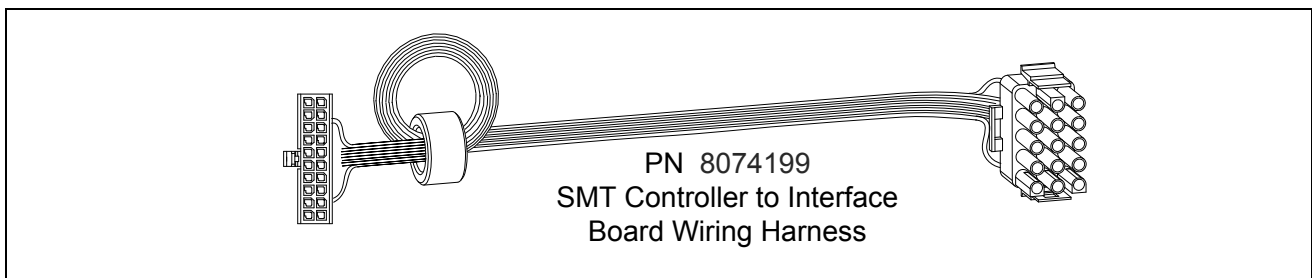

1.3.4.7 Component Box, Filter Pump and Basket Lift Wiring Harnesses

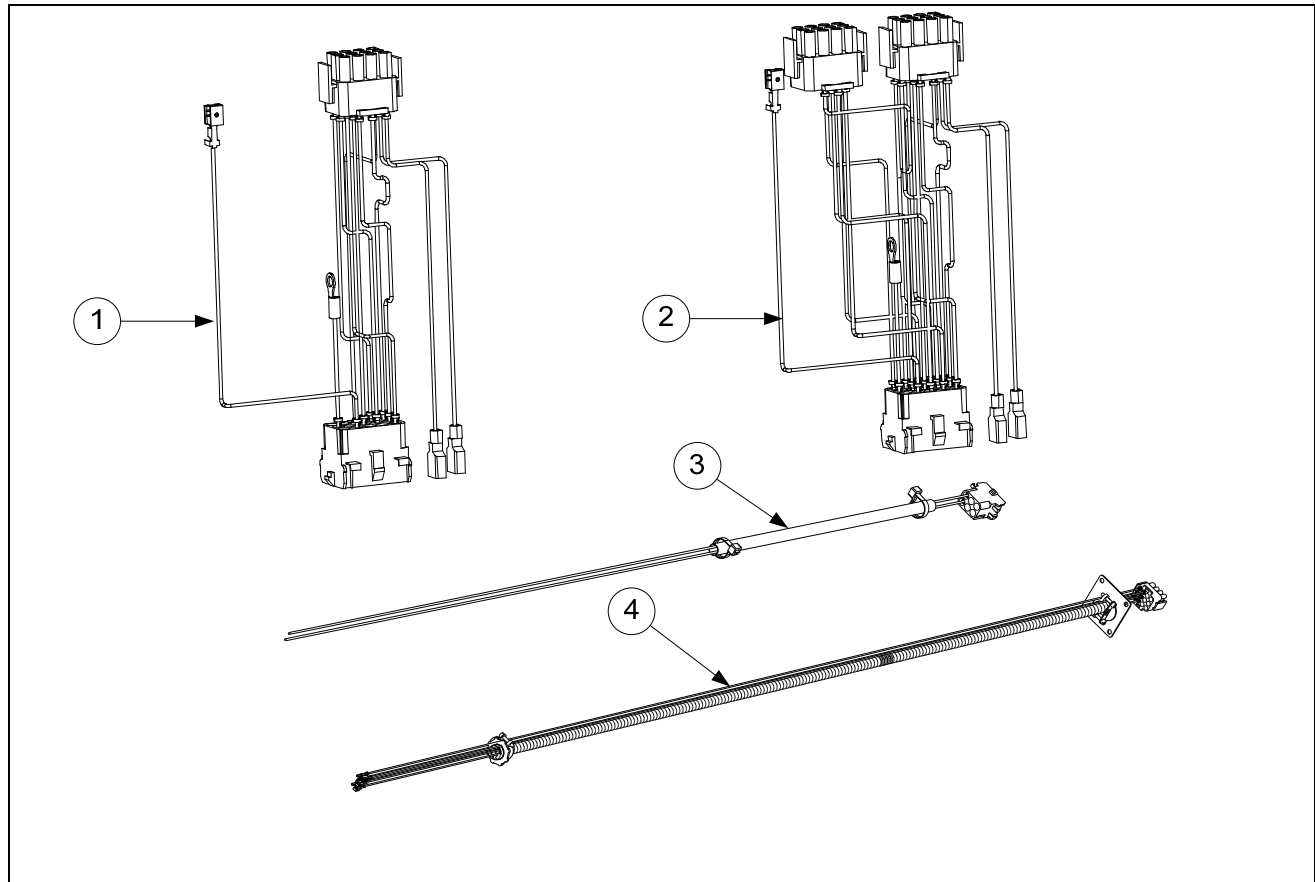

ITEM	PART #	COMPONENT
1	1065750SP	Full Vat Control Harness J4 to J2 (<i>Standard</i>)
2	1080490	Filter Pump C2 to Component Box Wiring Harness
3	1065962SP	Basket Lift Harness Assembly (<i>Standard</i>)

1.3.4.8 Basket Lift Harness

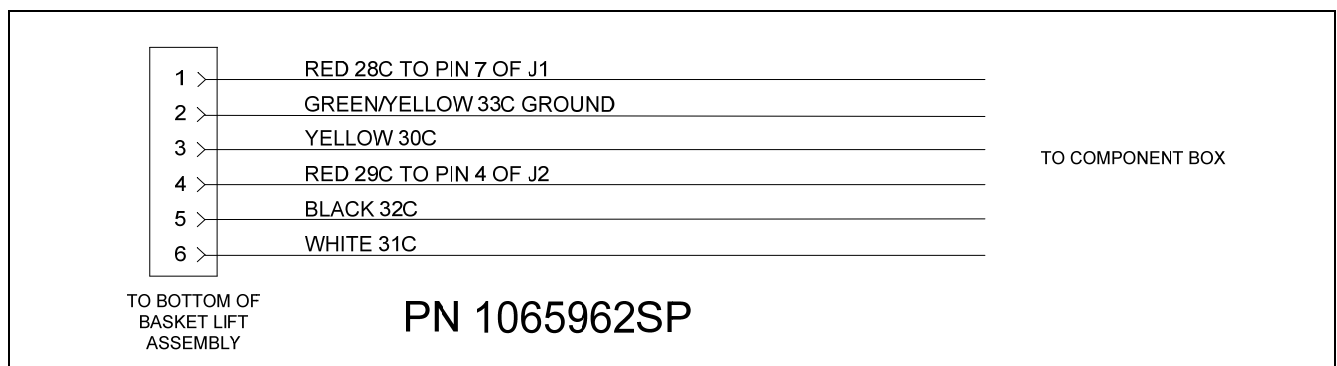

1.4 Filtration System Components
1.4.1 Filter Pan and Associated Components

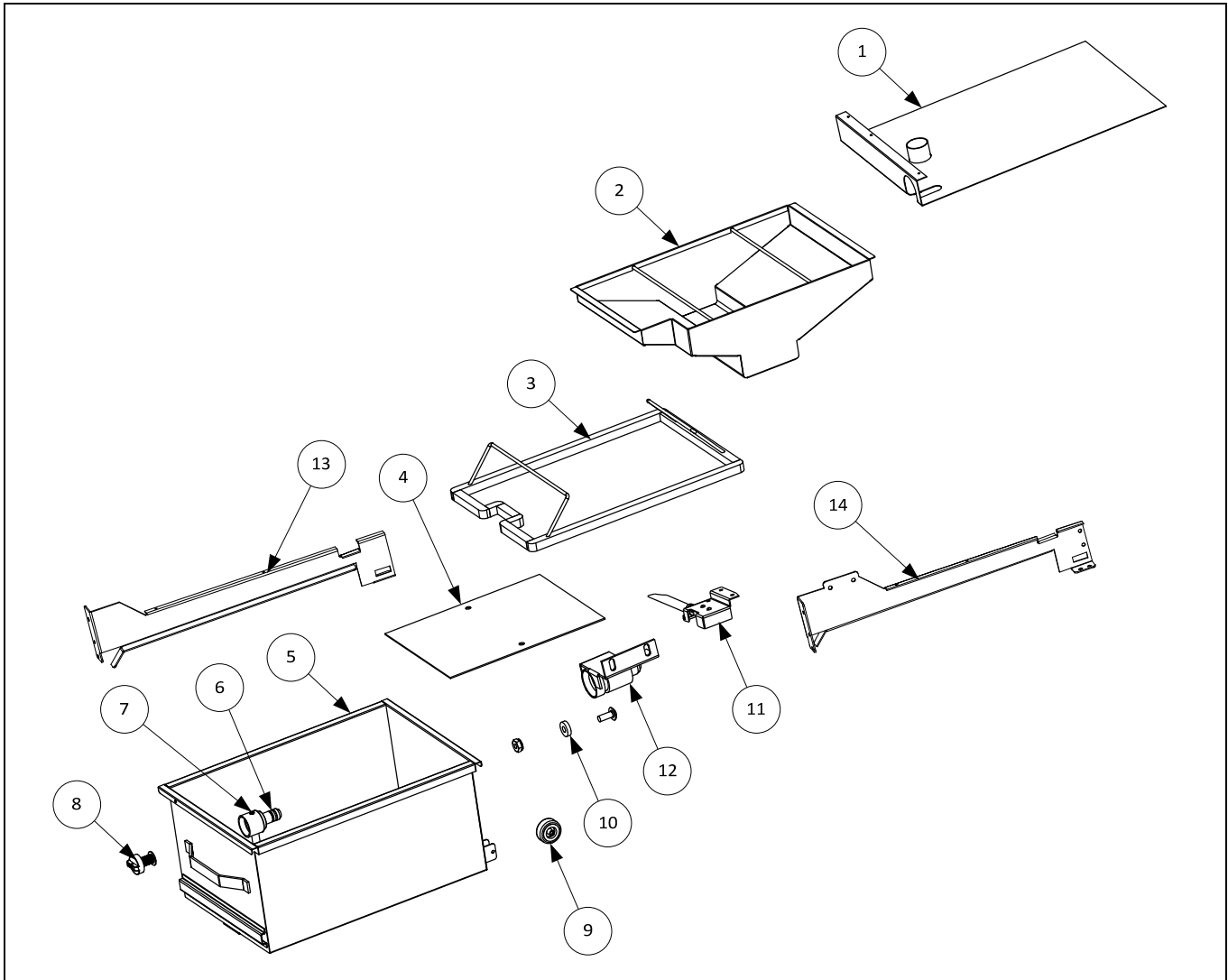

ITEM	PART #	COMPONENT
1	8239205	Lid, Filter Pan Fixed
	1087029SP	Pan, Filter Assy (includes items 2-10)
2	8239230	Crumb Tray
3	8103414	Hold-Down Ring 13.85 x 20.80
4	2204446	Sana Grid Filter Screen
5	8239209	Pan, Filter with casters
√ 6	8263288	O-Ring (Pkg. of 6; used with Item 5)
7	8130568	Plug, 1/8" Socket Head Pipe (used with Item 5; two required)
8	8238335	Screen, Suction Line Filter
9	8122337	Caster, 2" Rigid
10	8103007	Magnet, Pull Ring
11	1087010	Assembly, Filter Pan Switch
√ *	1065876SP	Sensor, Magnet
12	8239201	Suction Tube
13	2401449	Support, Left Filter Pan
14	2401450	Support, Right Filter Pan

* Not illustrated
 √ Recommended parts

1.4.2 Filter Pump and Associated Components

Pump plumbing may differ somewhat from illustration depending on configuration and date of manufacture.

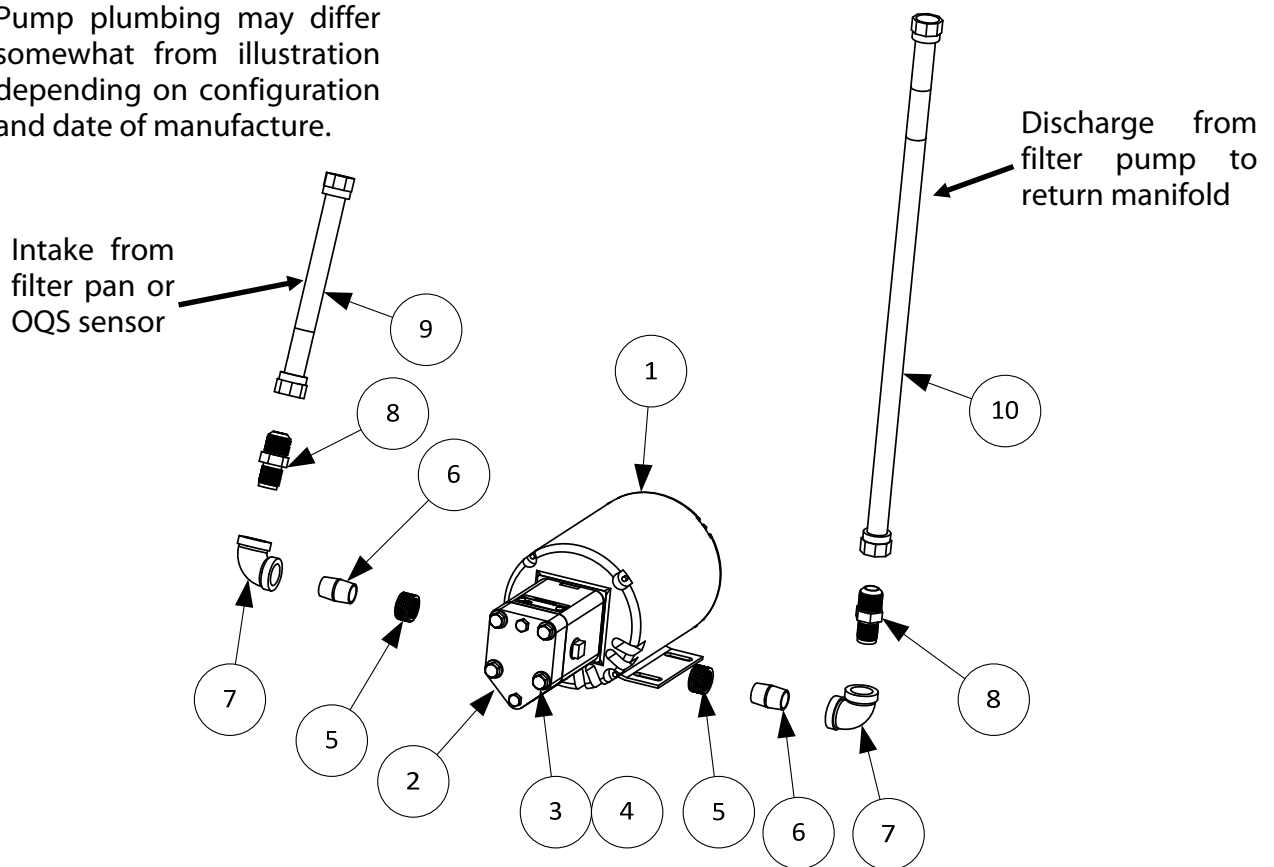

ITEM	PART #	COMPONENT
1		Motor and Gasket Kit
	8261785	100V 50/60 Hz
	8261712	115V 50/60 Hz
	8261756	208V 50/60 Hz
	8261270	220-240V 50/60 Hz
	8261755	250V 50/60 Hz
√ 2	8263192	Pump and Gasket Kit, 8 GPM
	8160093	Gasket, Pump/Motor
3	8091062	Cap Screw, 5/16"-18 5.50" NC Hex (Connects pump to motor)
4	8090194	Washer, Flat 5/16"
5	8130763	Bushing, 3/4" OD x 1/2" ID NPT Flush
6	8130022	Nipple, 1/2" x Close NPT BM
7	8130062	Elbow, 1/2" 90° BM
8	8101668	Adapter, 5/8" to 1/2" NPT Male
9	8101067	Flexline, 5/8" OD x 8.50-inch Oil Return (to filter suction tube or OQS sensor if applicable)
10	8101068	Flexline, 5/8" OD x 21.50-inch Oil Return (to oil return manifold)
*	1065912SP	Heater Strip Assembly, 208-250V 25W 18"

* Not illustrated

√ Recommended parts

1.5 Filtration Electronic Components

1.5.1 Manual Interface Board (MIB) Assembly

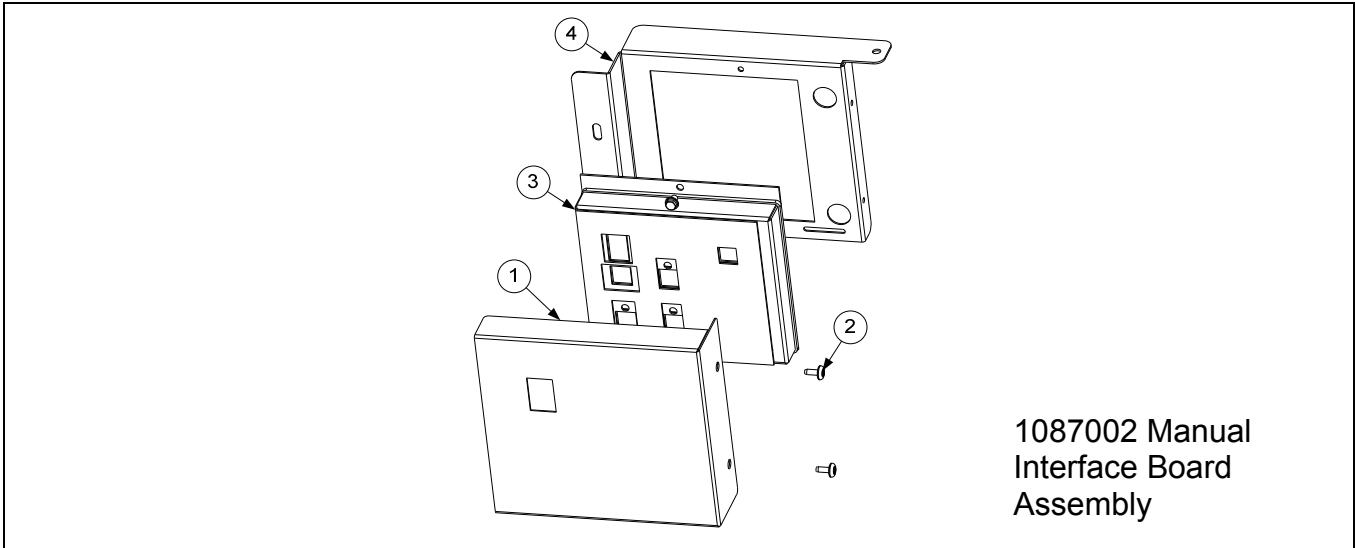

ITEM	PART #	COMPONENT
	1087002	Assembly, MIB 1814FQE
1	2401445	Cover, 1814FQ MIB
2	8091021	Screw, 10 x 3/8" Torx Pan
√ 3	1085772	Assembly, MIB w/ Frame Overlay
4	2401444	Bracket, 1814FQ MIB Mounting

√ Recommended parts

1.5.2 Automatic Intermittent Filtration (AIF) Board Assembly

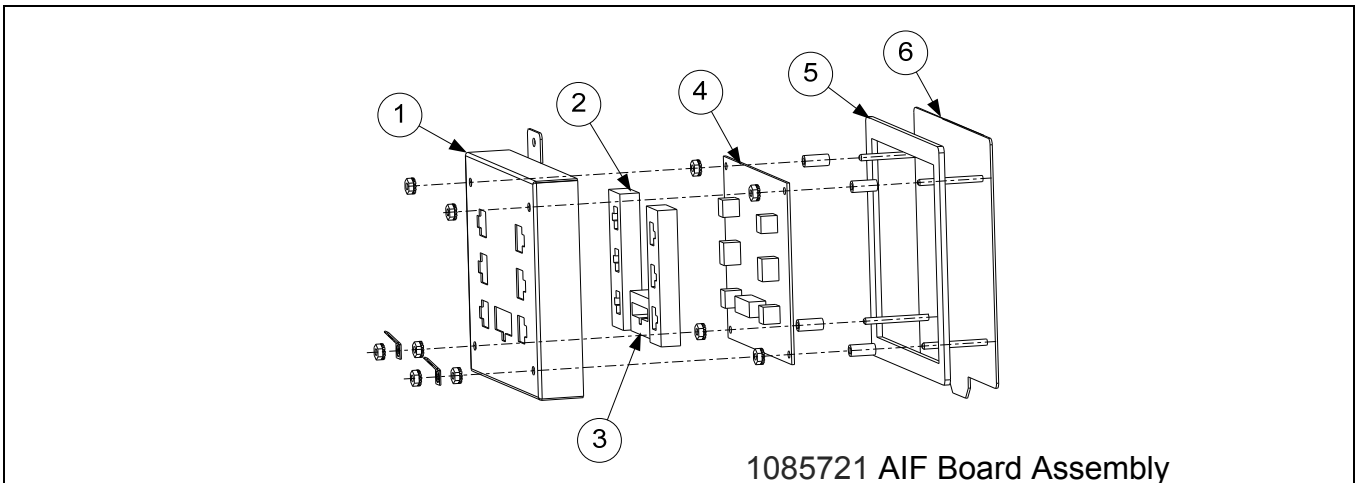

ITEM	PART #	COMPONENT
√	1085721	Assembly, AIF
1	8241991	Cover, AIF Board
2	8160814	Gasket, AIF Board
3	8160815	Gasket, Computer Board
4	1085720	Board, AIF
5	8160820	Seal, AIF Board
6	1080097	Panel Assembly, AIF Box

√ Recommended parts

1.6 Frypot Assemblies and Associated Parts

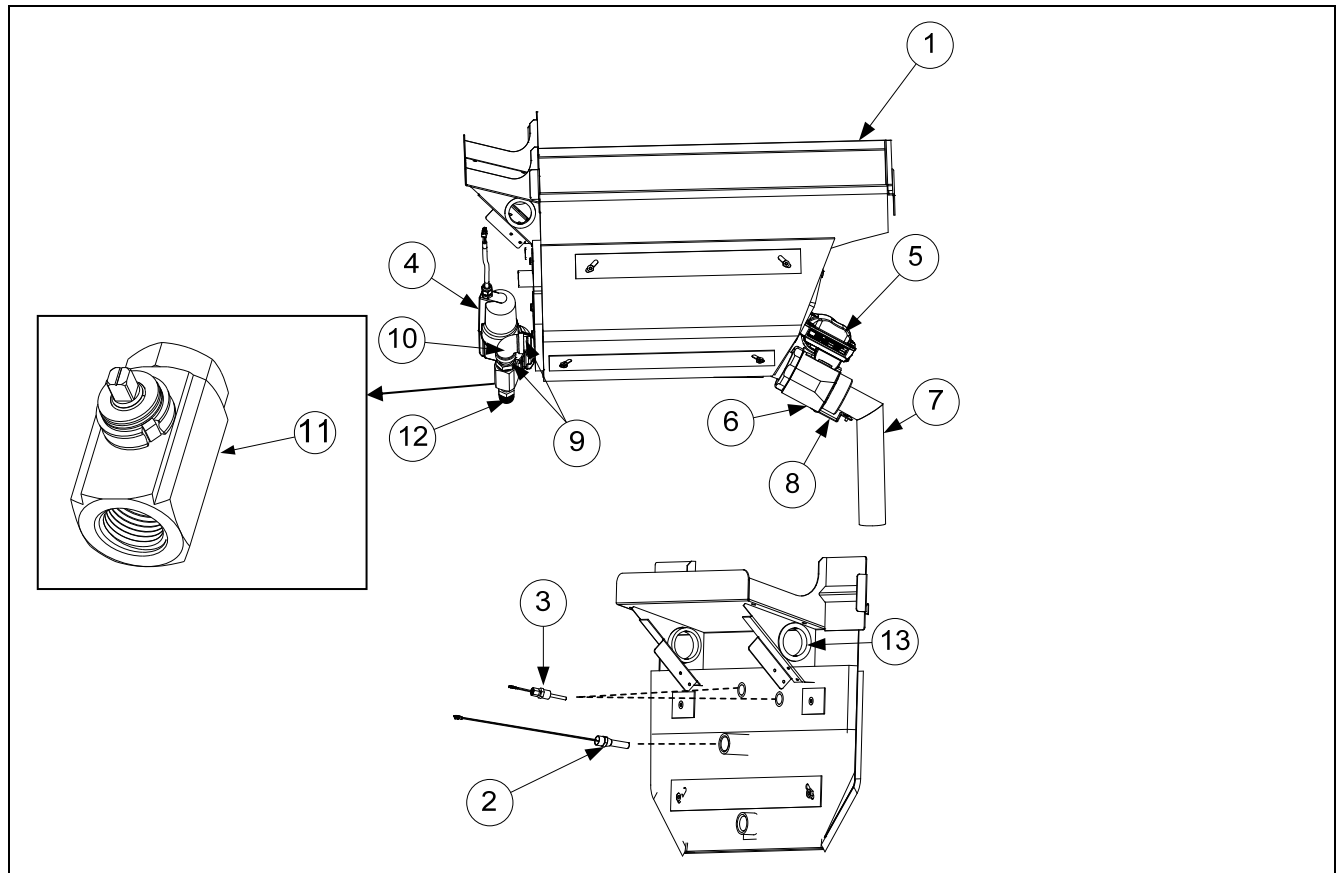

ITEM	PART #	COMPONENT
1	1087034	Frypot, FQ1814
√ 2		Thermostat Assembly, High-Limit Long Standard
	8262454	Non-CE Full Vat 425°F (218°C) (17kW FV and 14kW FV) (Color Coded Black 8067543)
	8262455	CE Full Vat 415°F (213°C) (14kW and 17kW CE) (Color-Coded Yellow 8068132)
√ 3	8262706	Probe, Kit AIF/ATO RTD
√ 4	8074961	Actuator, Rotary 24VDC (#1) Blue
√ 5	8074962	Actuator, Rotary 24VDC (#2) Black
√ 6	8103798	Valve, 1½" Drain Rotary Actuator (Drain)
7	8239206	Drain, Spout 1814E
8	2401459	Strap, Drain FQ1814E
9	8130022	Nipple, ½" x Close NPT BM
10	8130062	Elbow, ½" Blk 90°
√ 11	8103754	Valve, ½" NPT Rotary Actuator (Return)
12	8101668	Adaptor, Male ⅝" OD x ½"
13	8070128	Bushing Insulating Heyco

√ Recommended parts

1.7 Auto Top-Off Pump Assembly

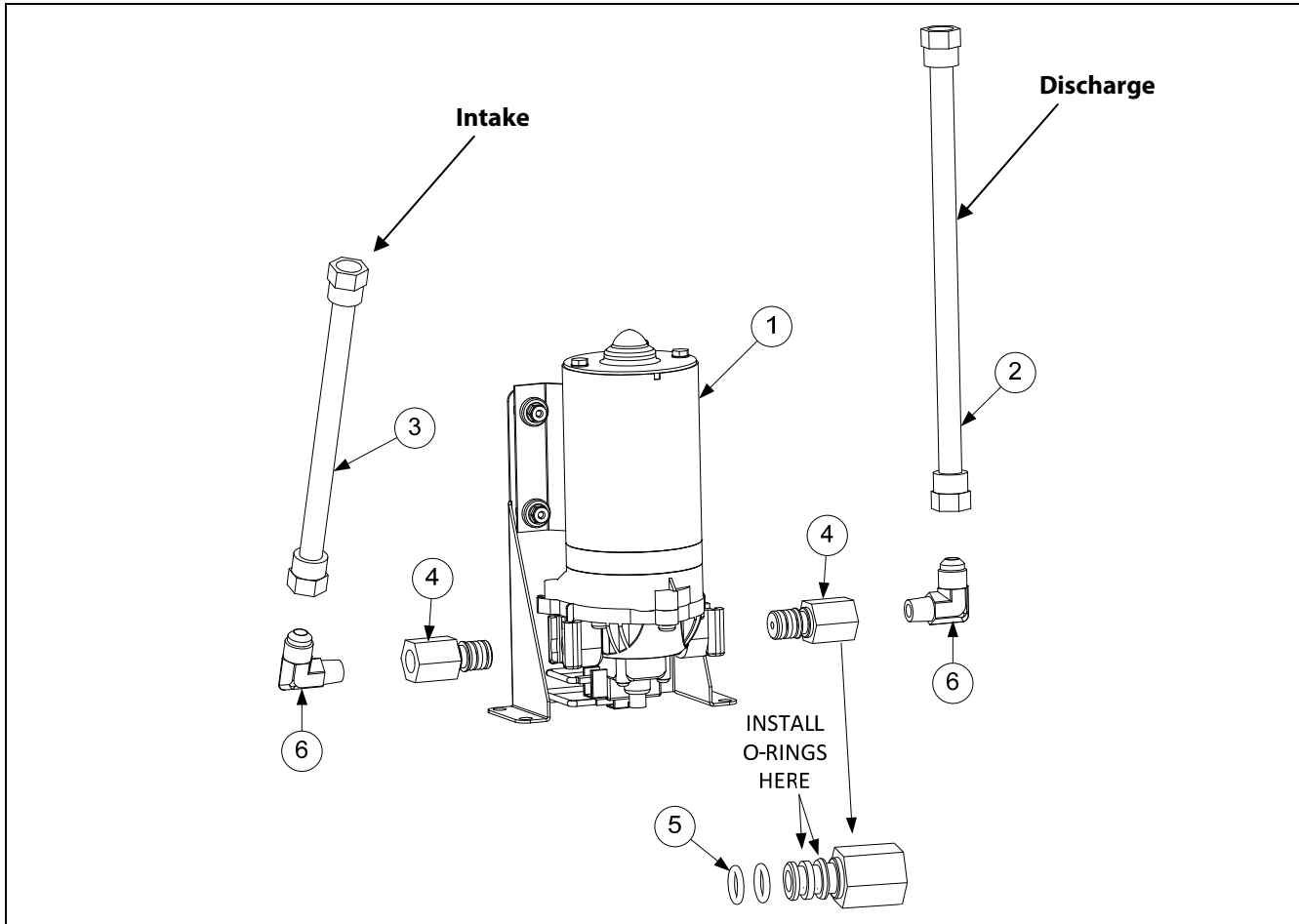

ITEM	PART #	COMPONENT
√ 1	1080639	Pump, Shurflo 24VAC
2	8104464	Flexline, 1/2" OD x 10-inch (Discharge to oil return manifold)
3	8103591	Flexline, 1/2" OD x 8-inch (In from bulk fresh oil solenoid)
4	8103666	Fitting, Shurflo Pump
5	8160782	O-Ring, Viton #111
6	8130940	Elbow, 1/4" NPT x 3/8" Flare

√ Recommended parts

1.8 Oil Plumbing Components
1.8.1 Bulk Manifold and Accessories

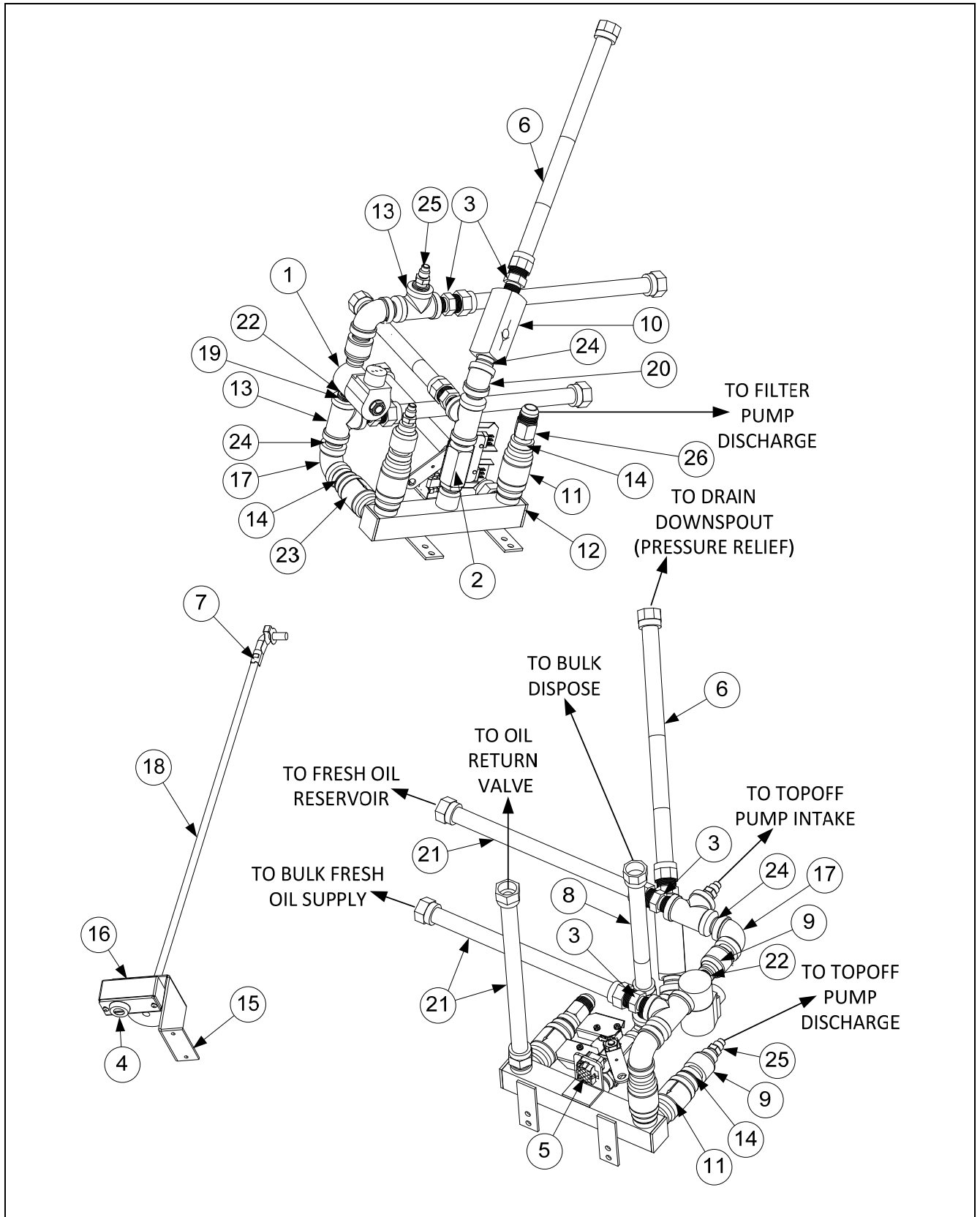

1.8.1 Bulk Manifold and Accessories cont.

ITEM	PART #	COMPONENT
√ 1	1066830	Solenoid Assembly
2	1080446	Valve, Bulk Waste Assembly (see section 1.8.2 for parts)
3	8101668	Adaptor, Male 5/8" OD x 1/2"
4	8103587	Lock and Key, RTI Waste Handle
5	8075786	Harness, Bulk Oil
6	8101057	Flexline, 5/8" OD x 13-inch long
7	8090601	Clip, Clevis Left Rod End
8	8101067	Flexline, 5/8" OD x 8.50-inch long
9	8130555	Reducer, Bell Fitting, 1/2" to 1/4" NPT BM
10	8103531	Valve, Check 20 PSI RTI bypass
11	8100667	Valve, Check 1/2" NPT 1 PSI
12	8104495	Manifold, FQ1814E Bulk/Return
13	8130003	Tee, 1/2" x 1/2" x 1/2" BM
14	8103738	Adaptor, Check Valve Close Nipple
15	2205656	Brace, RTI Handle
16	2208664	Cover, Handle Lock
17	8130062	Elbow, 1/2" BM 90°
18	8239213	Handle, Bulk Waste
19	8130304	Bushing, 1/2" x 1/4"
20	8130345	Elbow, 1/2" Blk 45°
21	8101055	Flexline, 5/8" OD x 11.50-inch long
22	8130838	Nipple, 1/4" NPT
23	8103583	Valve, Check 1/2" NPT 4 PSI
24	8130022	Nipple, 1/2" x close NPT BM
25	8103270	Fitting, 3/8" Flare x 1/4" NPT
26	8101669	Adaptor, Female 5/8" OD x 1/2"

√ Recommended parts

1.8.2 Bulk Dispose Waste Valve

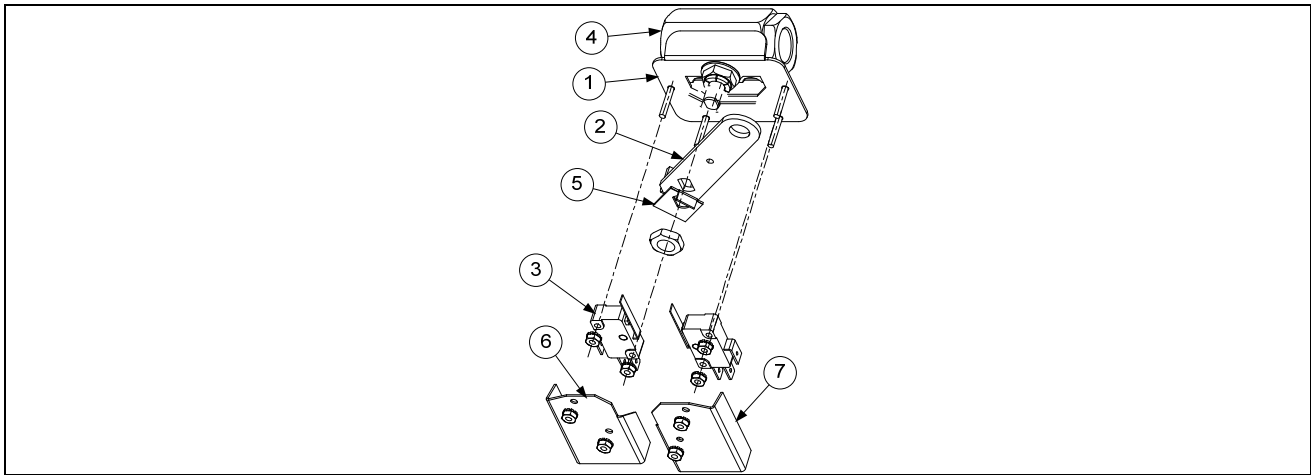

ITEM	PART #	COMPONENT
	1080446	Valve, Dispose Waste
1	1080445	Bracket, RTI Waste Valve
2	2205615	Handle, RTI Waste Valve
3	8074936	Microswitch, Gold Sealed
4	8100278	Valve, 1/2" Ball
5	9002935	Retainer, Nut Return Valve
6	9012348	Cover, DV Safety Switch
7	9022348	Cover, DV Safety Switch

1.8.3 Bulk Connection

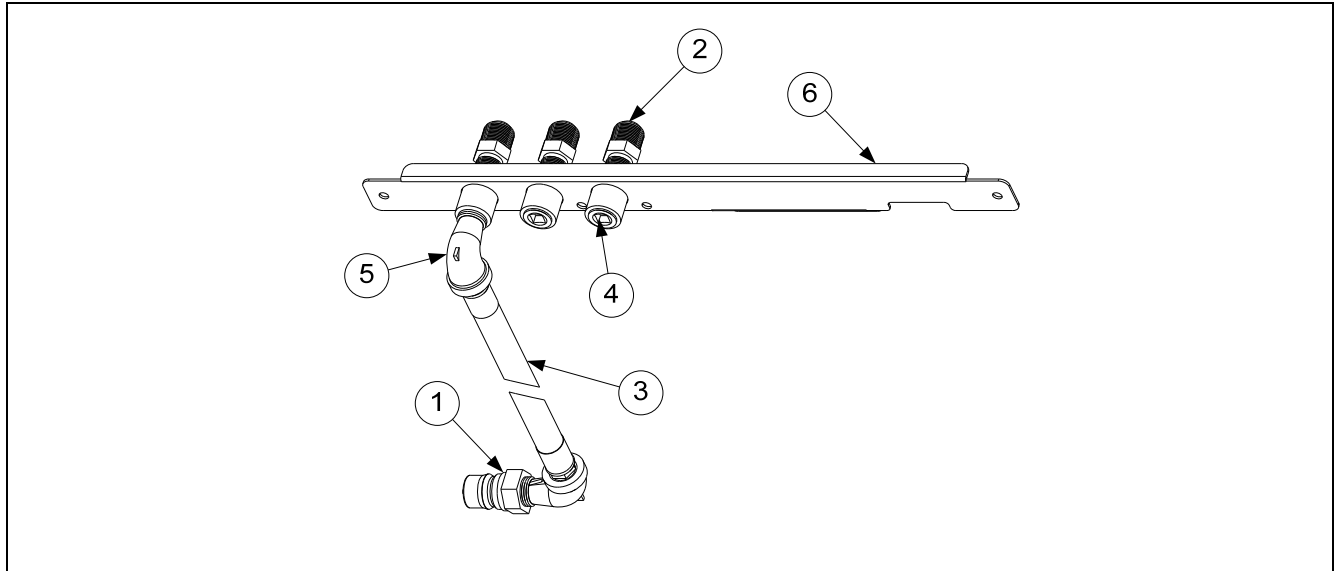

ITEM	PART #	COMPONENT
1	8100487	Coupling, Male Quick Disconnect
2	8101668	Adapter, 5/8" to 1/2" NPT Male
3	8103823	Hose
4	8130463	Plug, Pipe 1/2" NPT BM
5	8130616	Elbow, Street 1/2" x 1/2" NPT 90°
6	8239204	Mount, FQ1814E Oil Connection

1.8.4 Oil Quality Sensor (OQS) and Associated Parts

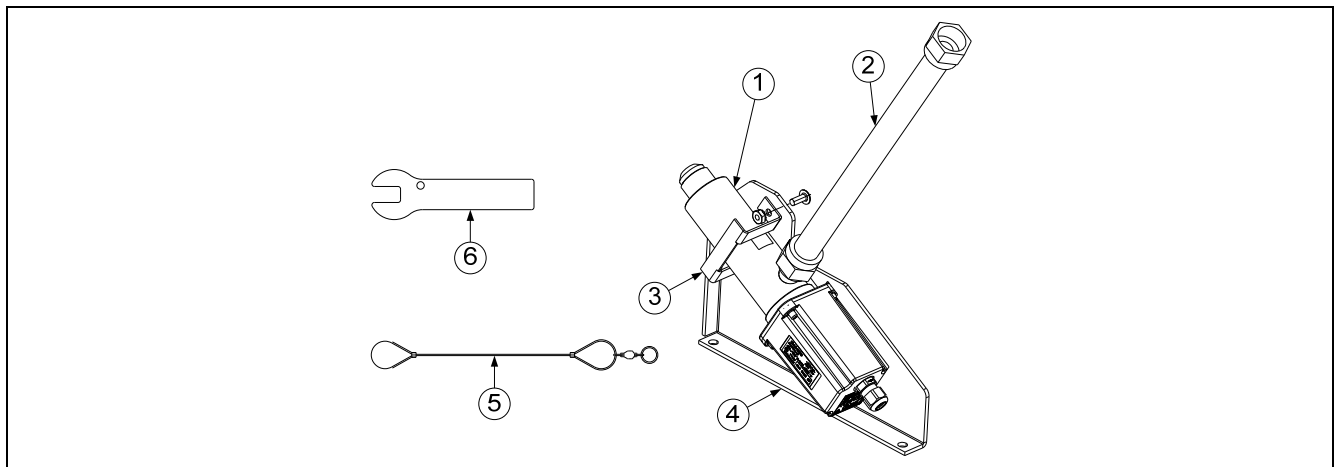

ITEM	PART #	COMPONENT
1	8263292	Sensor, FilterQuick OQS Replacement
2	8101055	Flexline, 5/8" OD x 11.5-inch
3	2401385	Retainer, OQS Sensor FQ
4	2401456	Mount, OQS Sensor FQ1814E
5	8104167	Lanyard, In-Line Filter
6	2401086	Wrench, Pre-Filter Cap

1.9 Basket Lift Assembly and Associated Parts

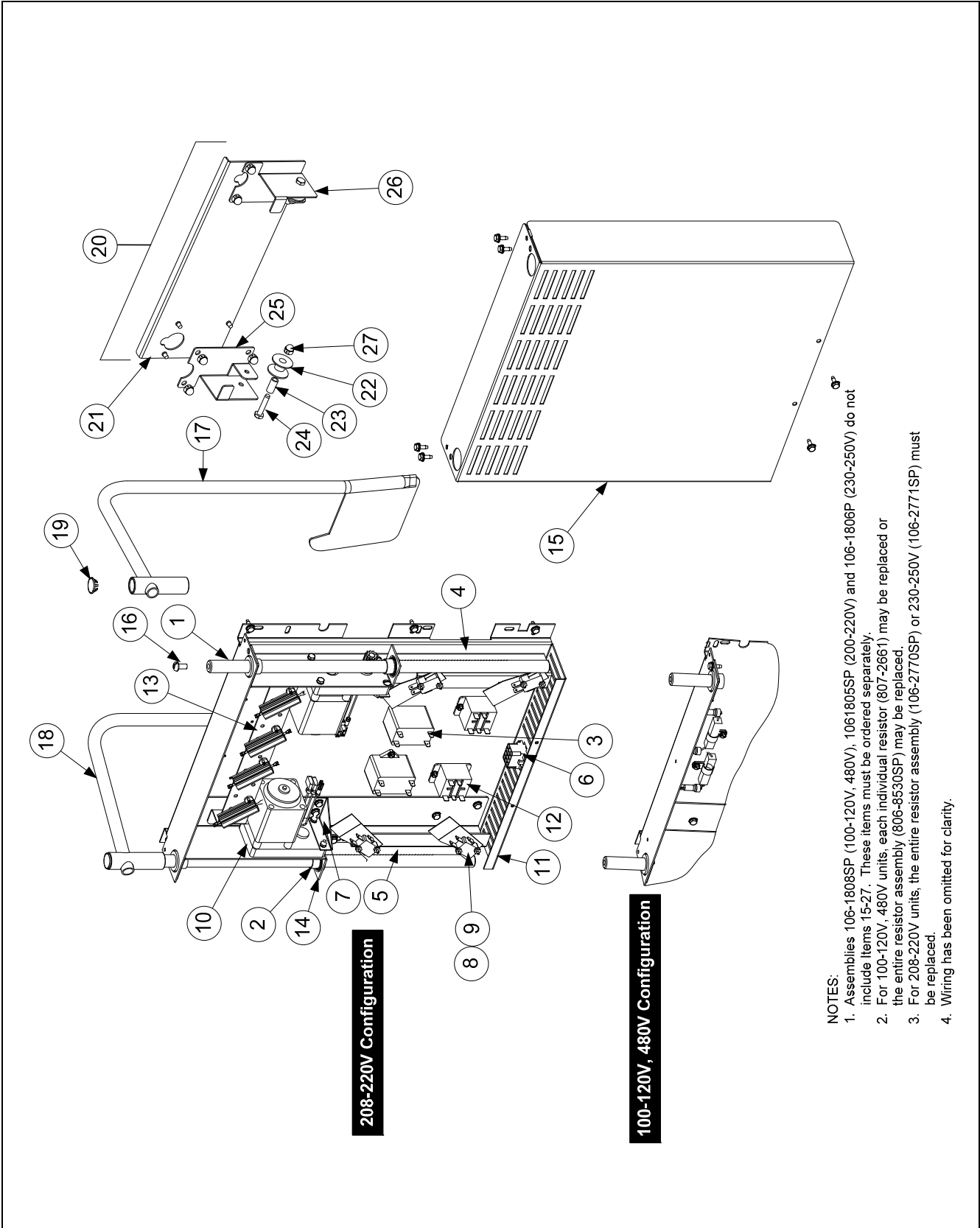

- NOTES:**
1. Assemblies 106-1808SP (100-120V, 480V), 1061805SP (200-220V) and 106-1806P (230-250V) do not include items 15-27. These items must be ordered separately.
 2. For 100-120V, 480V units, each individual resistor (807-2661) may be replaced or the entire resistor assembly (806-8530SP) may be replaced.
 3. For 208-220V units, the entire resistor assembly (106-2770SP) or 230-250V (106-2771SP) must be replaced.
 4. Wiring has been omitted for clarity.

1.9 Basket Lift Assembly and Associated Parts cont.

ITEM	PART #	COMPONENT
		Basket Lift Assemblies (see Note 1 in illustration)
	1061808SP	Basket Lift Assy, 100-120/480VAC w/Relay (Items 1-20) Assembly not shown
	1061805SP	Basket Lift Assy, 200-220VAC w/Relay (Items 1-20) Assembly shown
*	1061806SP	Basket Lift Assy, 230-250VAC w/Relay (Items 1-20) Assembly not shown
1	8101012	Rod, Basket Lift
2	8130035	Bushing, Bronze
3	8072513	Capacitor, 12.5 μ Fd 330VAC
4	9018499	Chassis, Left Basket Lift
5	9028499	Chassis, Right Basket Lift
6	8070159	Connector, 12-Pin Female
7	9005529	Gusset, Basket Lift Motor
8	8120442	Insulation, Microswitch
9	8072572	Microswitch
10	8065964SP	Motor Assy, 208-240VAC Modular Basket Lift
11	2002942	Mount, Modular Basket Lift
12	8071683	Relay, 12VDC
13		Resistor Assy
	8068530SP	100-120V Modular Basket Lift (see Note 2 in illustration)
	1062770SP	208-220VAC Modular Basket Lift (see Note 3 in illustration)
*	1062771SP	230-250VAC Modular Basket Lift (see Note 3 in illustration)
14	8090082	Ring, Bushing Retainer
15	9104776	Cover, Modular Basket Lift Rear S/S (Use 9004776 for Mild Steel)
16	8090127	Screw, ¼"-20 X ½" Slotted Round Head
17	8237986	Arm, Left Basket Lift
18	8237987	Arm, Right Basket Lift
19	8100179	Button, Plug
20	1082743SP	Roller Assy, Basket Lift
21	1082860	Mount, Basket Lift Roller
22	8100194	Roller, Basket Lift
23	8100374	Spacer, Basket Lift Roller
24	8090508	Bolt, ¼"-20 X 1¼ "
25	8237980	Guide, Basket lift Left
26	8238023	Guide, Basket lift Right
27	8090990	Nut, ¼-20 Cap
*	8241477	Tray, Drip Right
*	8241476	Tray, Drip Left
		Wire Assemblies
*	1065962	Harness, RE BL Interface (from Basket Lift Assy to control box)
*	WIR0166	Wire Assy, 100-250VAC Basket Lift

* Not illustrated

1.10 Wiring Connectors, Pin Terminals and Power Cords

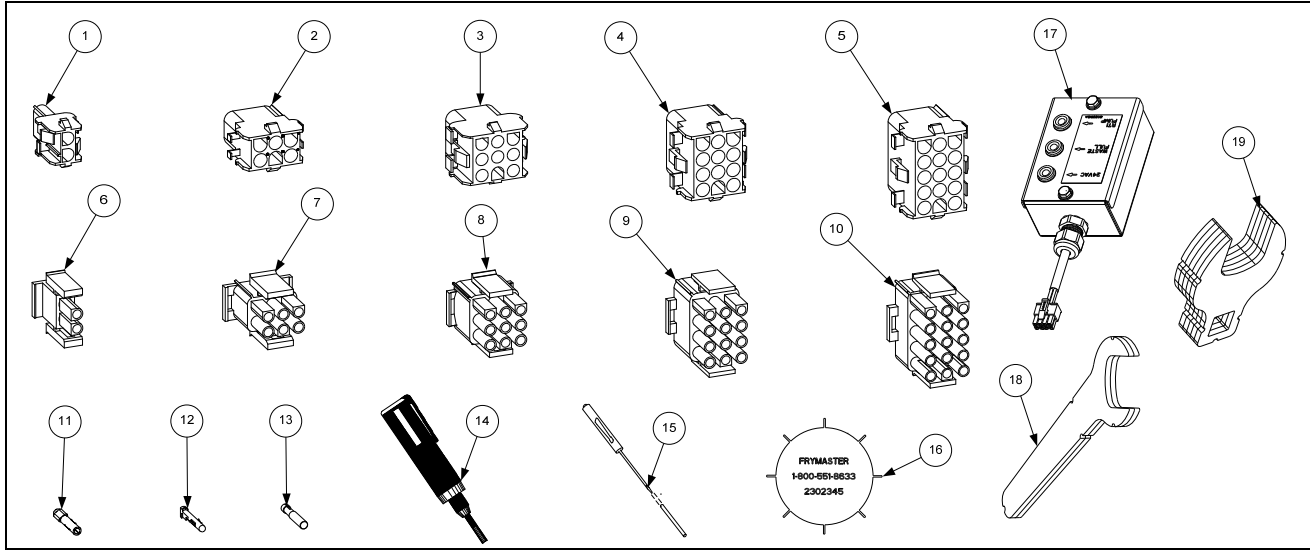

ITEM	PART #	COMPONENT
		Power Cords
		DELTA
*	8075625	Cordset, 3 Phase, 4 Wire, 113" 4 Gauge, Plug- Hubbell HBL-8462C
*	8075854	Cord, 3 Phase, 4 Wire, 113" 4 Gauge, Plug- None
		WYE
*	8073836	Cordset, FPP European Power, 5 Wire, 92", 10 Gauge, Plug- Hubbell C532P6S
*	1060516	Cordset, CE/Export Fryer and Motor with Ring Terminals 220-250V
*	8073835	Cable, Export, 5 Wire, 92", 10 Gauge, Plug- None
*	8073838	Cable, Export, 5 Wire, 147", 10 Gauge, Plug- None
*	8074979	Cordset, FPP European Power, 5 Wire, 92", 10 Gauge, Plug- Mennekes 532P6-14
*	8074143	Cable, Export, 5 Wire, 118", 10 Gauge, Plug- None
*	8073976	Cable, Export, 5 Wire, 177", 10 Gauge, Plug- None
*	8073977	Cable, Export China, 5 Wire, 165", 10 Gauge, Plug- None
*	8074005	Cable, Export Australia, 5 Wire, 104", 10 Gauge, Plug- None
		Connectors and Tools
1	8071068	2-Pin Female
2	8070158	6-Pin Female
3	8070156	9-Pin Female
5	8070159	12-Pin Female
5	8070875	15-Pin Female
6	8071067	2-Pin Male
7	8070157	6-Pin Male
8	8070155	9-Pin Male
9	8070160	12-Pin Male
10	8070804	15-Pin Male
11	8261341	Terminal, Female Split Pin (Pkg of 25)
12	8261342	Terminal, Male Split Pin (Pkg of 25)
13	8072518	Plug, Mate-N-Lock (Dummy Pin)
14	8070928	Extract Tool Pin Pusher
15	8064855	Pin Pusher Screwdriver Assembly
16	2302345	SMT Pin Extractor
*	8074660PK	SMT Pin Service Repair Kit
17	1080716	Box, RTI Test
18	8238990	Wrench w/a, 1-1/16" (used with OQS Sensor installation)
19	8238991	Wrench w/a, 1-1/16" Crows Foot (used with OQS Sensor installation)

* Not illustrated

1.11 Fasteners

ITEM	PART #	COMPONENT
*	8090429	Bolt, ¼-inch – 20 x 2.00-inch Hex Head ZP Tap
*	8090131	Bolt, ¼-inch -20 x ¾-inch Hex
*	8091020	Cap Screw, 5/16-inch-18 5.50" NC Hex (<i>Connects pump to motor.</i>)
*	8090448	Clip, Tinnerman
*	8261366	Nut, 4-40 Keps Hex (Pkg. of 25) (809-0237)
*	8261358	Nut, 6-32 Keps Hex (Pkg. of 25) (809-0049)
*	8090247	Nut, 8-32 Keps Hex
*	8090893	Nut, 8-32 Crown Acorn
*	8261376	Nut, 10-32 Keps Hex (Pkg. of 10) (809-0256)
*	8090766	Nut, 10-32 Keps Hex SS
*	8090581	Nut, ½ NPT Locking
*	8090020	Nut Cap 10-24 NP
*	8261372	Nut Grip ¼-inch ¼-20 Hex NP (Pkg. of 10) (809-0059)
*	8090417	Nut Flange ¼-inch ¼-20 Serr
*	8090535	Nut, "T" ¼-inch-20 x 7/16 SS
*	8090495	Nut, ¼-inch – 20 Press
*	8090540	Nut, Lock ½-inch-13 Hex 2-Way ZP
*	8261359	Screw, 4-40 x ¾-inch Slotted Round Head (Pkg. of 25) (809-0354)
*	8261365	Screw, 6-32 x ⅜-inch Slot Head (Pkg. of 25) (809-0095)
*	8090357	Screw, 6 x ⅜-inch Phillips Head NP
*	8090359	Screw, 8 x ¼-inch Hex Washer Head
*	8090360	Screw, 8 x ⅜-inch Hex Washer Slot Head
*	8261371	Screw, 8 x ½-inch Hex Head ZP (Pkg. of 25) (809-0361)
*	8090364	Screw, 8 x ⅝-inch Hex Washer Head ZP
*	8090518	Screw, 8-32 x ⅜-inch Hex Washer Slotted Head SS
*	8090104	Screw, 8-32 x ½-inch Slotted Head ZP
*	8261363	Screw, 8-32 x ½-inch NP (Pkg. of 25) (809-0103)
*	8261360	Screw, 10-24 x 5/16-inch Round Slot Head ZP (Pkg. of 25) (809-0024)
*	8261330	Screw, 10-32 x ⅜-inch Slot Head SS (Pkg. of 25) (809-0117)
*	8091003	Screw, 10-32 x ⅜-inch Hex Trim Head SS
*	8090270	Screw, 10-32 x ½-inch Phillips Head ZP
*	8261375	Screw, 10-32 x ¾-inch Hex Trim Head SS (Pkg. of 5) (809-0401)
*	8091000	Screw, 10-32 x 1¼-inch Hex Sck C/S
*	8261374	Screw, 10 x ½-inch Hex Head (Pkg. of 25) (809-0412)
*	8090266	Screw, 10 x ½-inch Phillips Head ZP
*	8090434	Screw, 10 x ⅜-inch Hex Washer Head NP
*	8091021	Screw, 10 x ⅜-inch Torx Pan Type B
*	8090123	Screw, 10 x ¾-inch Slot Head
*	8261389	Screw, 1/4-20 x ¾-inch Hex Head ZP (Pkg. of 10) (809-0131)
*	8090582	Washer ½ NPT Locking
*	8090184	Washer, #10 LK ZP
*	8090190	Washer, .625 X .275 X 40 Flat SS
*	8090191	Washer, Lock ¼ Spring ZP
*	8090193	Washer, Flat ¼ Nylon
*	8090194	Washer, Flat 5/16-inch ZP

1.12 Wiring Diagram for Harness Part Numbers

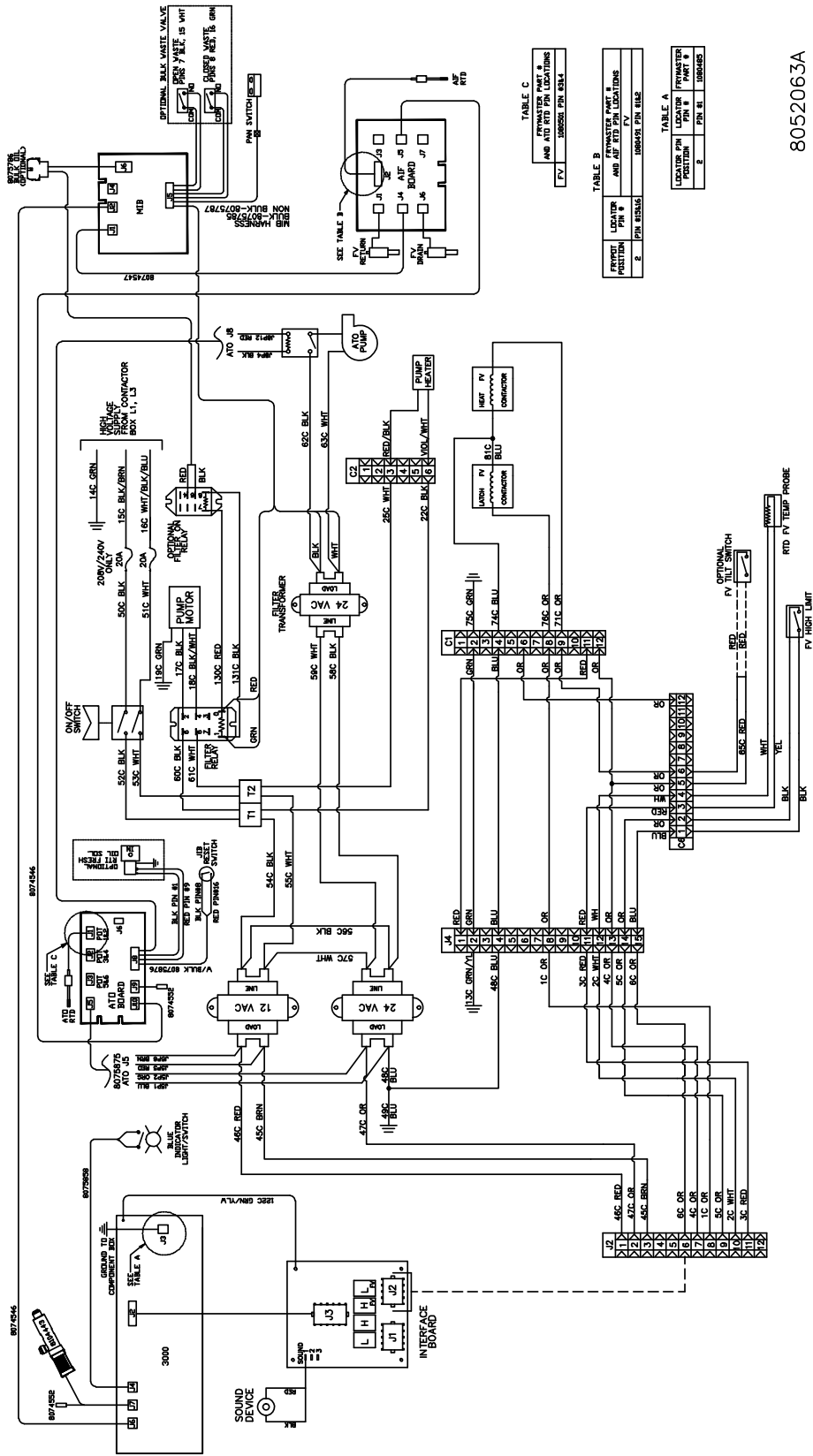

8052063A



FRYMASTER
8700 LINE AVENUE, SHREVEPORT, LA 71106-6800

318-865-1711
800-551-8633
844-724-CARE (2273)
WWW.FRYMASTER.COM
EMAIL: FRYSERVICE@MTWFS.COM



Every new piece of Manitowoc Foodservice equipment comes with KitchenCare™ and you choose the level of service that meets your operational needs from one restaurant to multiple locations.

StarCare – Warranty & lifetime service, certified OEM parts, global parts inventory, performance audited

ExtraCare – CareCode, 24/7 Support, online/mobile product information

LifeCare – Install & equipment orientation, planned maintenance, KitchenConnect™, MenuConnect

Talk with KitchenCare™ - 1-844-724-CARE - www.mtwkitchencare.com



To learn how Manitowoc Foodservice and its leading brands can equip you, visit our global web site at www.manitowocfoodservice.com, then discover the regional or local resources available to you.

