

# FilterQuick™ FQG30

## Gas Fryer

### Parts Manual

This manual is updated as new information and models are released. Visit our website for the latest manual.



8 1 9 7 1 1 6  
Part Number: FRY\_P\_8197116 06/2017

#### **NOTICE**

IF, DURING THE WARRANTY PERIOD, THE CUSTOMER USES A PART FOR THIS WELBILT EQUIPMENT OTHER THAN AN **UNMODIFIED** NEW OR RECYCLED PART PURCHASED DIRECTLY FROM FRYMASTER OR ANY OF ITS AUTHORIZED SERVICERS, AND/OR THE PART BEING USED IS MODIFIED FROM ITS ORIGINAL CONFIGURATION, THIS WARRANTY WILL BE VOID. FURTHER, FRYMASTER AND ITS AFFILIATES WILL NOT BE LIABLE FOR ANY CLAIMS, DAMAGES OR EXPENSES INCURRED BY THE CUSTOMER WHICH ARISE DIRECTLY OR INDIRECTLY, IN WHOLE OR IN PART, DUE TO THE INSTALLATION OF ANY MODIFIED PART AND/OR PART RECEIVED FROM AN UNAUTHORIZED SERVICER.

#### **NOTICE**

This appliance is intended for professional use only and is to be operated by qualified personnel only. A Frymaster Factory Authorized Servicer (FAS) or other qualified professional should perform installation, maintenance, and repairs. Installation, maintenance, or repairs by unqualified personnel may void the manufacturer's warranty. See Chapter 1 of this manual for definitions of qualified personnel.

#### **NOTICE**

Drawings and photos used in this manual are intended to illustrate operational, cleaning and technical procedures and may not conform to onsite management operational procedures.

#### **NOTICE TO OWNERS OF UNITS EQUIPPED WITH CONTROLLERS**

##### **U.S.**

This device complies with Part 15 of the FCC rules. Operation is subject to the following two conditions: 1) This device may not cause harmful interference, and 2) This device must accept any interference received, including interference that may cause undesired operation. While this device is a verified Class A device, it has been shown to meet the Class B limits.

##### **CANADA**

This digital apparatus does not exceed the Class A or B limits for radio noise emissions as set out by the ICES-003 standard of the Canadian Department of Communications.

#### **DANGER**

Improper installation, adjustment, maintenance or service, and unauthorized alterations or modifications can cause property damage, injury, or death. Read the installation, operating, and service instructions thoroughly before installing or servicing this equipment. Only qualified service personnel may convert this appliance to use a gas other than that for which it was originally configured.

#### **WARNING**

After installation of a gas fryer and after any maintenance to the gas system of a gas fryer-manifold, valve, burners, etc. – check for gas leaks at all connections. Apply a thick soapy solution to all connections and ensure there are no bubbles. There should be no smell of gas.

#### **DANGER**

Adequate means must be provided to limit the movement of this appliance without depending upon the gas line connection. Single fryers equipped with legs must be stabilized by installing anchor straps. All fryers equipped with casters must be stabilized by installing restraining chains. If a flexible gas line is used, an additional restraining cable must be connected at all times when the fryer is in use.

#### **DANGER**

The front ledge of the fryer is not a step! Do not stand on the fryer. Serious injury can result from slips or contact with the hot oil.

#### **DANGER**

Do not store or use gasoline or other flammable liquids or vapors in the vicinity of this or any other appliance.

 **DANGER**

**Do not spray aerosols in the vicinity of this appliance while it is in operation.**

 **DANGER**

**This product contains chemicals known to the state of California to cause cancer and/or birth defects or other reproductive harm.**

**Operation, installation, and servicing of this product could expose you to airborne particles of glasswool or ceramic fibers, crystalline silica, and/or carbon monoxide. Inhalation of airborne particles of glasswool or ceramic fibers is known to the State of California to cause cancer. Inhalation of carbon monoxide is known to the State of California to cause birth defects or other reproductive harm.**

 **DANGER**

**Improper installation, adjustment, maintenance or service, and unauthorized alterations or modifications can cause property damage, injury, or death. Read the installation, operating, and service instructions thoroughly before installing or servicing this equipment.**

 **DANGER**

**Keep all items out of drains. Closing actuators may cause damage or injury.**

 **DANGER**

**Prior to movement, testing, maintenance and any repair on your Frymaster fryer; disconnect ALL electrical power cords from the electrical power supply.**

 **WARNING**

**Use caution and wear appropriate safety equipment to avoid contact with hot oil or surfaces that may cause severe burns or injury.**

**FILTERQUICK™ FQG30 SERIES GAS FRYERS**  
**PARTS MANUAL**  
**TABLE OF CONTENTS**

---

**CHAPTER 1: Parts List**

1.1	Accessories.....	1-1
1.2	Doors, Sides, Flue Caps, Top Caps and Casters.....	1-2
1.3	Drain Valves and Associated Parts .....	1-2
1.3.1	Rotary Actuator Drain Valve.....	1-2
1.4	Drain Tube Sections and Associated Parts .....	1-3
1.5	Electronics and Electrical Components.....	1-4
1.5.1	High-Limit Thermostat and Temperature Probe .....	1-4
1.5.2	Component Boxes.....	1-4
1.5.3	Transformer Boxes .....	1-6
1.5.4	Controllers and Associated Components .....	1-7
1.5.5	Control Panel Frames and Push Pull Rod Assembly .....	1-8
1.5.6	Control Panel Frames and Push Button Assembly.....	1-9
1.6	Wiring.....	1-10
1.6.1	Controller, MIB, AIF, ATO Wiring Harnesses and Cord Sets .....	1-10
1.6.2	Main Wiring Harnesses .....	1-11
1.7	Frypots and Associated Components.....	1-12
1.7.1	Full-Vat Frypot Components .....	1-12
1.7.2	Dual-Vat Frypot Components .....	1-14
1.7.3	Frypot Assemblies and Associated Parts .....	1-16
1.8	Oil Return Manifolds .....	1-17
1.9	Return Valve.....	1-17
1.10	Gas Supply and Combustion System Components .....	1-18
1.11	Gas Valves and Associated Components .....	1-20
1.12	Filtration System Components .....	1-22
1.13	Filtration Electronic Components .....	1-23
1.13.1	MIB (Manual Interface Board) Assembly.....	1-23
1.13.2	AIF (Automatic Intermittent Filtration) Linear Actuator Board Assembly.....	1-24
1.14	ATO (Automatic Top-Off) Components.....	1-24
1.14.1	JIB Cradle, JIB Box, JIB Cap and Pick-Up Assembly and ATO Board Assemblies.....	1-24
1.14.2	ATO Pump Assembly Non-Bulk .....	1-25
1.14.3	ATO Pump Assembly Bulk.....	1-26
1.14.4	Shortening Melting Unit .....	1-27
1.15	Bulk Oil System Components .....	1-28
1.15.1	Bulk Dispose Waste Valve and Test Box.....	1-28
1.15.2	Bulk Manifold and Accessories .....	1-29
1.16	Basket Lift Assembly and Associated Parts .....	1-31
1.17	Oil Quality Sensor (OQS) and Associated Parts.....	1-33
1.18	Simplified Wiring Diagrams.....	1-34
1.18.1	FilterQuick™ FQG30 Series Simplified Wiring with Push Buttons .....	1-34
1.18.2	FilterQuick™ FQG30 Series Simplified Wiring with Push Pull Handles .....	1-35

# FILTERQUICK™ FQG30 SERIES GAS FRYERS

## PARTS LIST

### 1.1 Accessories

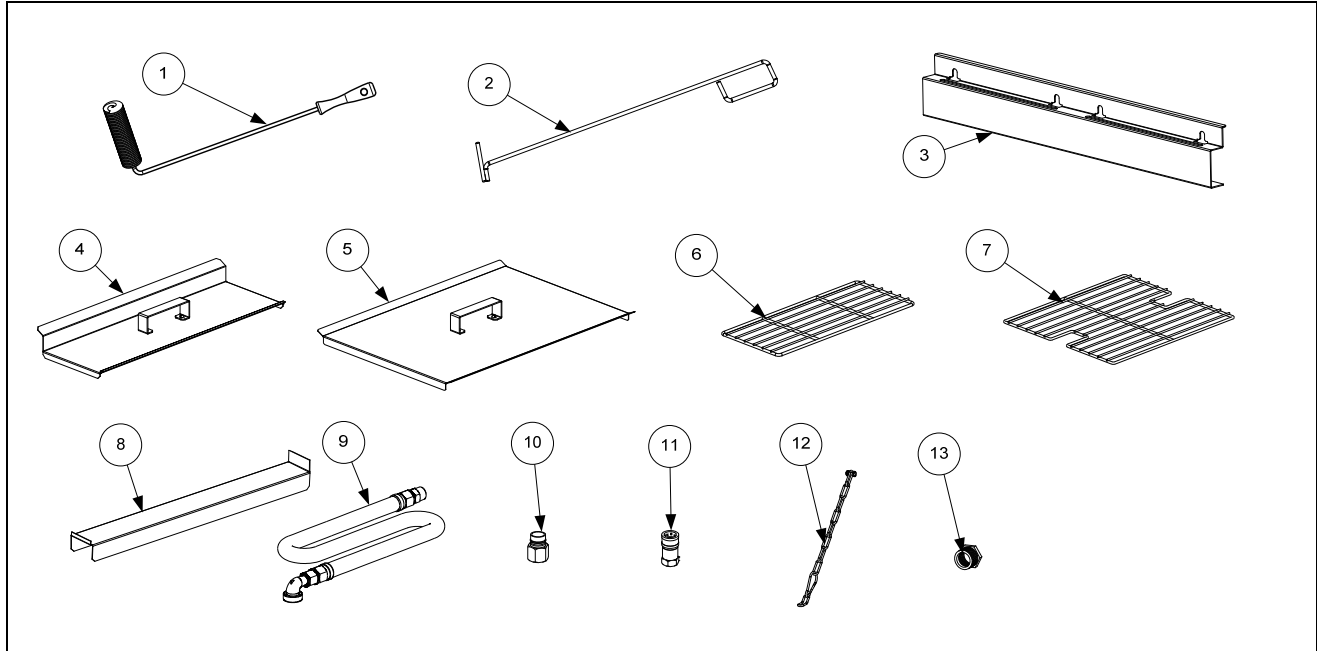

ITEM	PART #	COMPONENT
1	8030429	Brush, Frypot
2	8030388	Fryers Friend
3	2307495	Hanger, Basket Two Station <b>(use two for a Four Station fryer)</b>
	2307497	Hanger, Basket Three Station
4	1068931	Cover, Frypot, Dual Vat
5	1068930	Cover, Frypot, Full Vat
	8260993SP	Handle Kit, Frypot Cover (includes handle and screws)
6	8030372	Basket Support Rack, Dual Vat
*	8030375	Basket Support Rack, Full Vat
7	8030136	Basket Support Screen, Full Vat (screen w/handle used in place of Item 8)
8	2302975	Connecting Strip, Frypot <b>prior to 07/2014</b>
	1086156	Connecting Strip, Frypot <b>after 06/2014</b>
9	8100478	Gas Line, 1-Inch Dormont Flexible
	8061698SP	36-Inch (for gas line only (w/o Items 10 and 11), use 8100088)
	8061699	48-Inch (for gas line only (w/o Items 10 and 11), use 8100085)
10	8100074	Quick-Disconnect Fitting, 1-Inch Male
11	8100073	Quick-Disconnect Fitting, 1-Inch Female
12	8103745	Quick Disconnect Fittings, 3/4" set (includes male and female connectors)
13	8260900	Kit, Chain Restraint
14	8261045	Bushing, Flexible Gas Line (8130032)
*	8030002	Powder, Filter (80- 1-Cup Applications)
*	8030445	Pack, 100-Sheet Filter Paper 16.5 X 25.5

\* Not illustrated.

## 1.2 Doors, Sides, Flue Caps, Top Caps and Casters

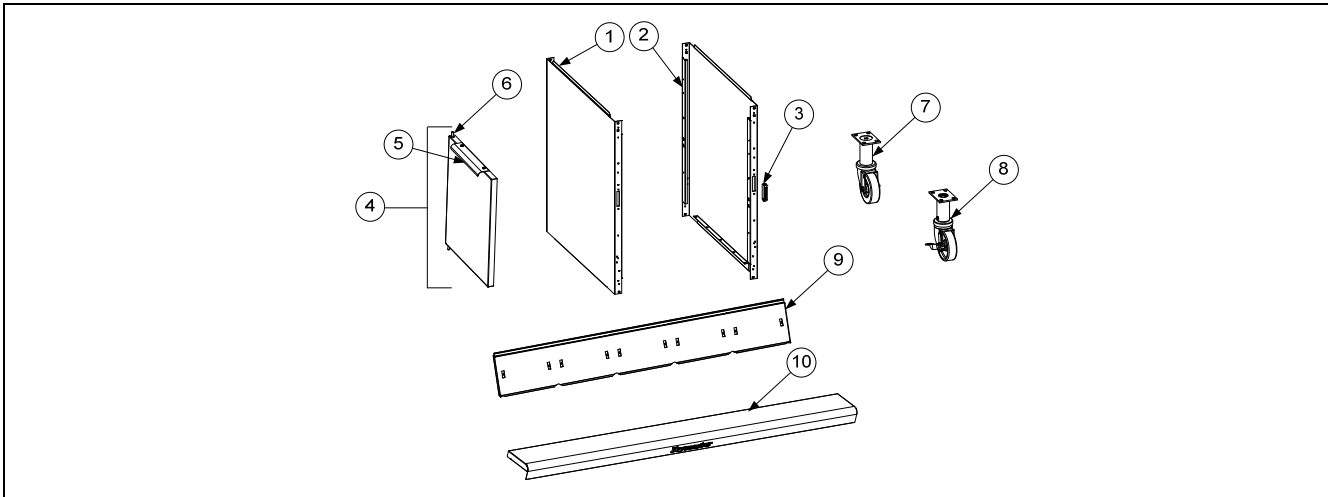

ITEM	PART #	COMPONENT
1	2317908	Side, Standard Cabinet Left SS
2	2327908	Side, Standard Cabinet Right SS
3	8101105	Magnet, Door (vertical) (use 8102346 for horizontal over filter pan)
4	1064397	Door, Left or Right (Left shown – move handle to bottom for right) (use 1080915 for Door w/ Manual Holder)
5	2304960	Handle, Eurolook Door
6	1064067	Pin Assembly, Door
*	8100275	Spring, Door Pin
*	8090970	Retaining Ring
*	2307192	Hinge, Door Lower
7	8100327	Caster without Brake
8	8100944	Caster with Brake
9		Flue Cap-Stainless Steel
	8237724	Two Station Fryer <b>prior to 07/2014 (use 8238922 after 06/2014)</b>
	8237727	Three Station Fryer <b>prior to 07/2014 (use 8238923 after 06/2014)</b>
	8237728	Four Station Fryer <b>prior to 07/2014 (use 8238924 after 06/2014)</b>
	8237752	Five Station Fryer <b>prior to 07/2014 (use 8238925 after 06/2014)</b>
10		Top Cap (Cap for 5-station fryer shown)
	8241913	Two Station Fryer <b>prior to 07/2014 (use 1086158 after 06/2014)</b>
	8236635	Three Station Fryer <b>prior to 07/2014 (use 1086159 after 06/2014)</b>
	8236636	Four Station Fryer <b>prior to 07/2014 (use 1086160 after 06/2014)</b>
	1083030	Five Station Fryer <b>prior to 07/2014 (use 1086161 after 06/2014)</b>

\* Not illustrated.

## 1.3 Drain Valves and Associated Parts

### 1.3.1 Rotary Actuator Drain Valve

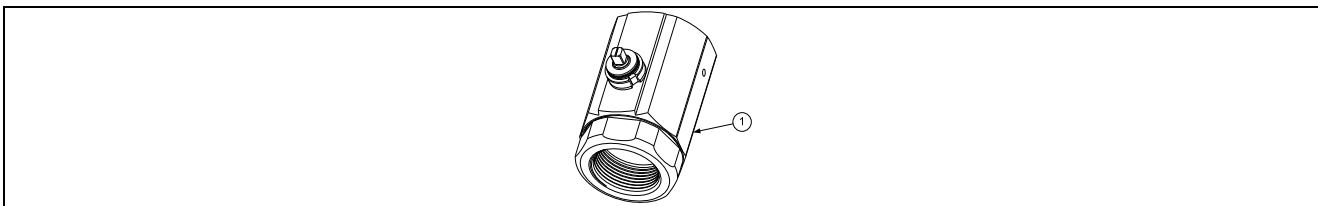

ITEM	PART #	COMPONENT
1	8103755	Valve, 1¼" NPT Rotary Actuator

## 1.4 Drain Tube Sections and Associated Parts

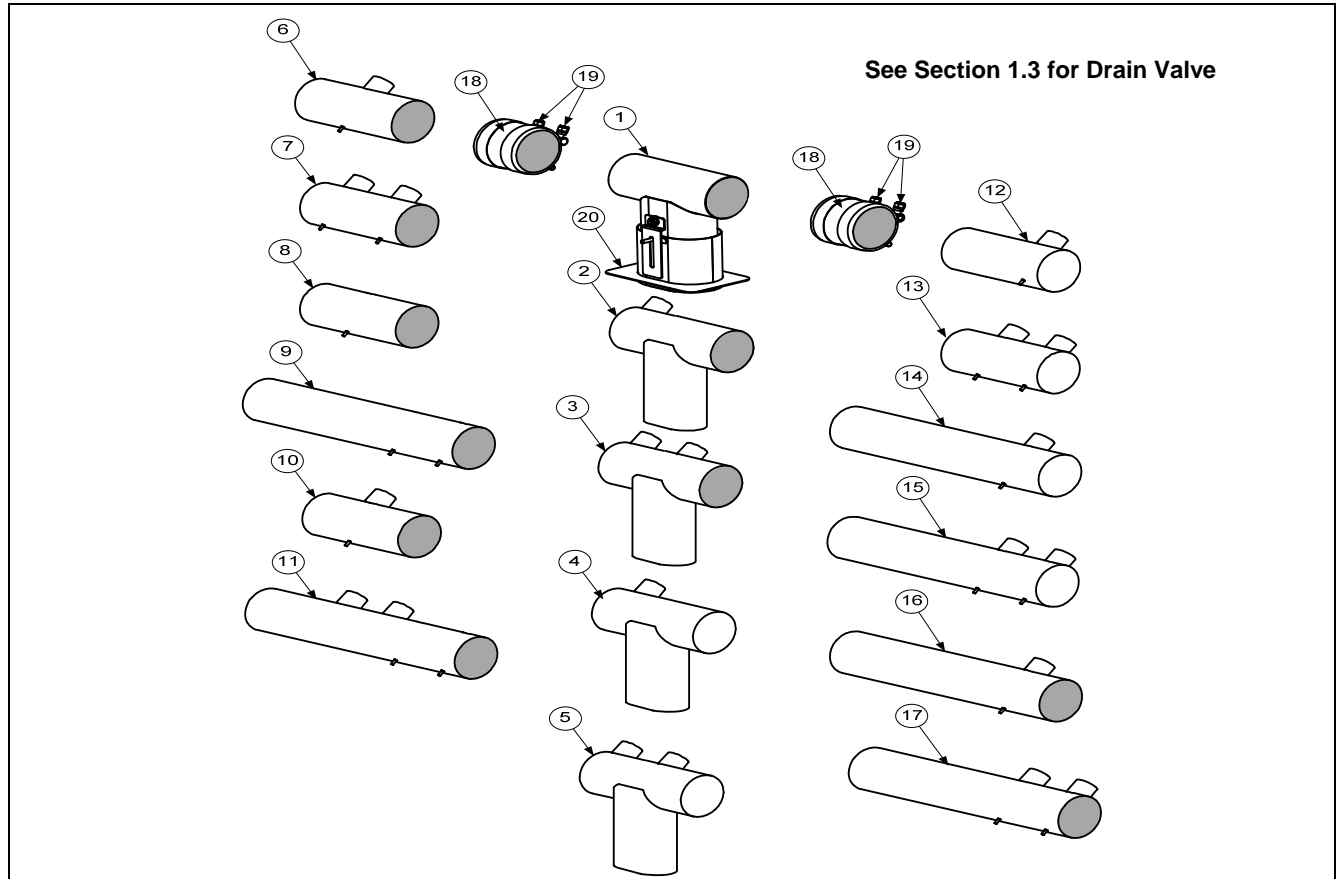

ITEM	PART #	COMPONENT
1	1085906	Drain Tube, Dump Left Closed/Right End Open ( <i>Use 1085915 for Bulk</i> )
2	1085904	Drain Tube, Dump Full-Vat Left Closed/Right End Open ( <i>Use 1085911 for Bulk</i> )
3	1085917	Drain Tube, Dump Dual-Vat Left Closed/Right End Open ( <i>Use 1085916 for Bulk</i> )
4	1085905	Drain Tube, Dump Full-Vat Left Closed/Right End Closed ( <i>Use 1085914 for Bulk</i> )
5	1085919	Drain Tube, Dump Dual-Vat Left Closed/Right End Closed ( <i>Use 1085918 for Bulk</i> )
6	8237322	Drain Tube, Full-Vat Left and Right Open
7	8237324	Drain Tube, Dual-Vat Left and Right Open
8	8103550	Drain Tube, Short, Open Both Ends
9	8103551	Drain Tube, Long, Open Both Ends
10	8238812	Drain Tube, Full -Vat Left and Right Open
11	8238813	Drain Tube, Dual-Vat Left and Right Open
12	8237330	Drain Tube, Full-Vat Left Open/Right End Closed
13	8237331	Drain Tube, Dual-Vat Left Open/Right End Closed
14	8237329	Drain Tube, Full-Vat Left Open/Right End Closed
15	8237326	Drain Tube, Dual-Vat Left Open/Right End Closed
16	8237328	Drain Tube, Full-Vat Left and Right Open 15.31"
	8238791	Drain Tube, Full-Vat Left and Right Open 18.95"
17	8237327	Drain Tube, Dual-Vat Left and Right Open 15.31"
	8238814	Drain Tube, Dual-Vat Left and Right Open 18.95"
18	8160772	Sleeve
19	8090969	Clamp
*	8160630	Vinyl Cap
20	8237480	Guard, Filter Lid Splash 2 battery
	8237915	Guard, Filter Lid Splash 3,4 and 5 battery

\* Not illustrated.

## 1.5 Electronics and Electrical Components

### 1.5.1 High-Limit Thermostat and Temperature Probe

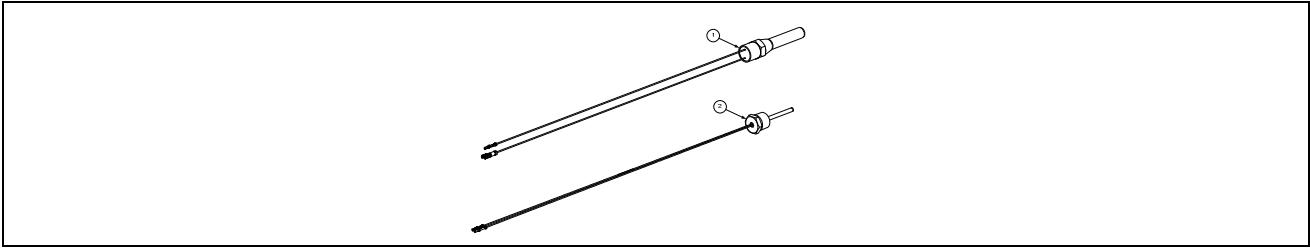

ITEM	PART #	COMPONENT
√ 1	8261177	Thermostat Assembly, HE FM High-Limit 425°F/218°C
√ 2	8262900	Temperature Probe

√ Recommended parts.

### 1.5.2 Component Boxes

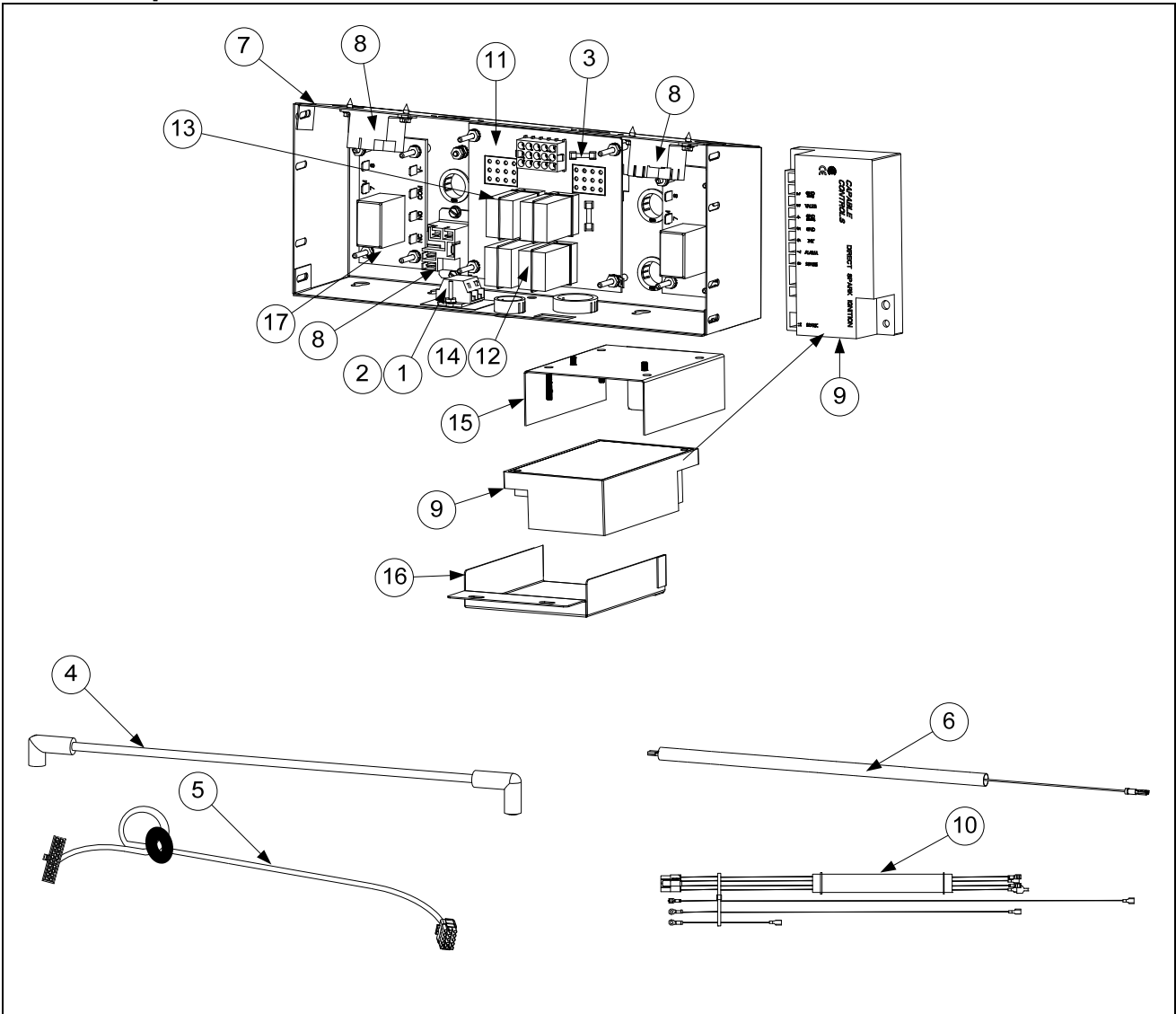



## 1.5.2 Component Boxes cont.

ITEM	PART #	COMPONENT
1	8101164	Block, One-Piece Screwless Terminal
2	8160217	Insulation, Terminal Block Paper
√ 3	8073843	Fuse 3A 250V Domestic
	8073293	Fuse 5A 125V <b>International Only</b>
√ 4	8075008	Cable, 21-inch Ignition ( <i>Domestic, Australia</i> )
*	8075009	Cable, Ignition 19" ( <i>CE</i> )
*	8075266	Cable, Ignition, ( <i>Australia</i> )
*	8073484	Connector, Rajah
5	8075165	Cable, 20-pin Controller to 15-pin Interface Board – SMT
6	8066085SP	Wire Assembly, Ignitor
7	2206102	Box, One-Piece Component
√ 8	8071683	Relay, 15A 12VDC Blower, OIB, Reset Switch
√	8070012	Relay, 18A 24VAC Between OIB Time Delay Board and Gas Valve, ( <i>Australia</i> )
√ 9	8075691†	Ignition Module, Single-Spark Capable Control ( <i>CE, Non-CE, CSA and AGA</i> )
	8075664†	Ignition Module, Single-Spark Fenwal ( <i>AGA</i> ), ( <i>Australia</i> )
10	8075813	Harness, Interface Board to Ignition Module ( <i>Capable Controls</i> )
*	1084801	Harness, Interface Board to Ignition Module ( <i>Australia</i> )
	1086057	Wire Assembly, Full Vat Right ( <i>Honeywell</i> )
	1086059	Wire Assembly, Full Vat Left ( <i>Honeywell</i> )
	1086058	Wire Assembly, Dual Vat ( <i>Honeywell</i> )
√ 11	8262264	Interface Board Kit SMT
	8074330	Speaker Adapter Harness SMT
	8074343	Wire Harness, SMT Interface Board to Ignition Module
	8064973	Interface Board – Australia Only
√ 12	8070833	Relay, DPDT 5A 12VDC Latch (See <b>NOTE 1</b> .)
√ 13	8070834	Relay, SPDT 15A 12VDC Basket Lift (See <b>NOTE 2</b> .)
14	8102243	Spring, Relay Retaining
15	1086052	Plate, Ignition Module
16	8242090	Cover, Ignition Module
17	8074812	Relay, 7-second Time Delay 120V ( <b>U.S., Canadian and Mexico units</b> )
	8074934	Relay, 7-second Time Delay 220V, 230V, 240V and 250V units ( <b>International units</b> )
*	1060531SP	Fuse Assembly, Inline ( <i>not used on all models</i> )
*	8072659	Switch, Momentary ( <i>Control Power Reset, only used in far left component box</i> )
*	8074403	Speaker SMT

\* Not illustrated.

√ Recommended parts.

† For Full-vat and Dual-vat units, use two Single Spark Ignition Modules.

**NOTE 1:** In full-vat units, only two latch relays (Item 12) are used, located in the sockets on the right side of the interface board. These relays are located in the bottom sockets of the interface board and control the heating circuit.

**NOTE 2:** The relays in the top sockets control the basket lifts.

### 1.5.3 Transformer Boxes

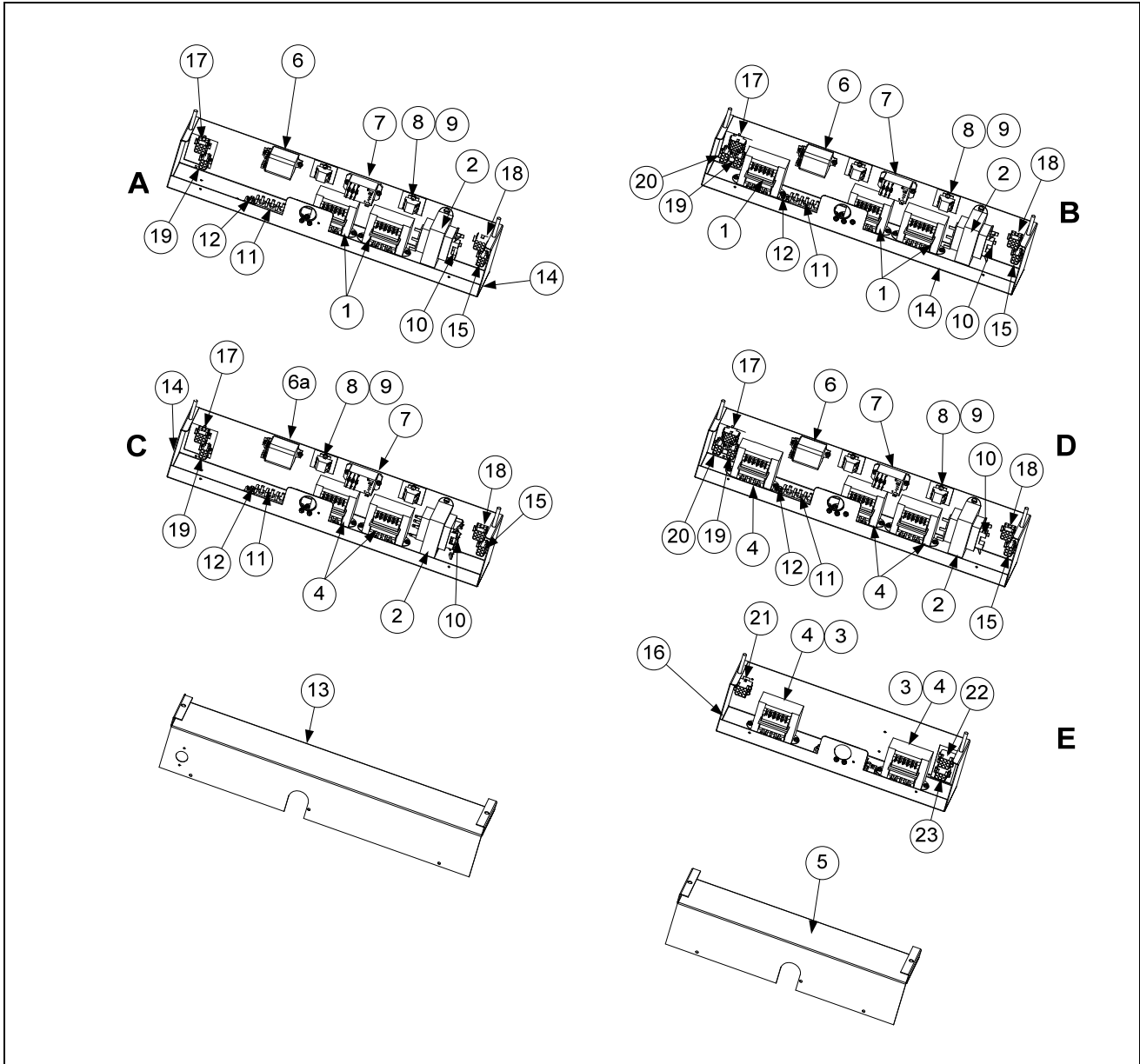

ITEM	PART #	COMPONENT
		Box Assembly, Transformer
A	1085658	GL230 and 430 (430 has added cordset 1081788) (use 1085885 Solid Shortening)
B	1085746	GL330 (use 1085886 Solid Shortening) (530 has added cordset 1081788)
C	1085808	GL230 CE Export (430 has added cordset 1081788) (use 1085890 Solid Shortening)
D	1085809	GL330 CE Export (use 1085891 Solid Shortening) (530 has added cordset 1081788)
E	1085959	FQ 430/530 CE Export 100v/120v (use 1085903 for 208/222/230/240V)
√ 1	8074978	Transformer, 100-120V/24V 62VA V/F Dual Voltage
√ 2	8072181	Transformer, 100-120V/24V 62VA Filter and MIB
√ 3	8074978	Transformer, V&F Dual Voltage 100-120V/12V 30VA /24V 50VA
4	8075129	Transformer, V&F Dual Voltage 208/222/230/240V

√ Recommended parts.

### 1.5.3 Transformer Boxes cont.

ITEM	PART #	COMPONENT
√ 5	2206514	Cover, GL30 4-Battery Transformer Box
√ 6	8074346	Relay, DPDT 20A 120VAC (Control Reset Button) <i>(used for control power reset in domestic units)</i>
√ 6a	8074770	Relay, DPDT 20A 240V (Control Reset Button) <i>(used for control power reset in international units)</i>
√ 7	8074482	Relay, Filter 30A 24VDC DPDT
8	8160217	Insulation, Terminal Block Paper
9	8101164	Block, One-Piece Screwless Terminal
√ 10	8071597	Fuse, 3amp Slo-Blow
11	8071973	Terminal, Post
12	8070070	Terminal, Ground Lug
13	2203191	Cover, Large Transformer Box
14	8236324	Box, Large Transformer/Filter
15	1068133	Cable Assembly, Transformer Box Line GL230, 330, 430, 230 and 330 CE Export and 430 CE Export
	1085895	Cable Assembly, Transformer Box Line GL230, 330, 430, 230 and 330 CE Export and 430 CE Export Solid Shortening
16	8237638	Box, Transformer/Filter GL30 4-Battery
17	1085774	Cable Assembly, Transformer Box Filter Pump GL230, 330, 230 and 330 CE Export
	1085894	Cable Assembly, Transformer Box Filter Pump GL230, 330, 230 and 330 CE Export Solid Shortening
18	1080994	Cable Assembly, Transformer Box #1 GL230,330, 230 and 330 CE Export
19	1080995	Cable Assembly, Transformer Box #2 GL230, 330, 230 and 330 CE Export
20	1080996	Cable Assembly, Transformer Box #3 GL330 and 330 CE Export
21	1085664	Cable Assembly, Transformer Box #4 FQ430 and 530 Non-CE and CE Export
22	1085663	Cable Assembly, Transformer Box #3 FQ430 and 530 Non-CE and CE Export
23	1085662	Harness Assembly, Cord set Female
*	WIR 1093	Wire Assembly, GL430/530 (used in Item E)
*	WIR 0798	Wire Assembly, GL330 Transformer/Filter Box (used in Item B and D)
*	WIR 0799	Wire Assembly, GL230/430 Transformer/Filter Box (used in Item A, C)

\* Not illustrated

√ Recommended parts.

### 1.5.4 Controllers and Associated Components

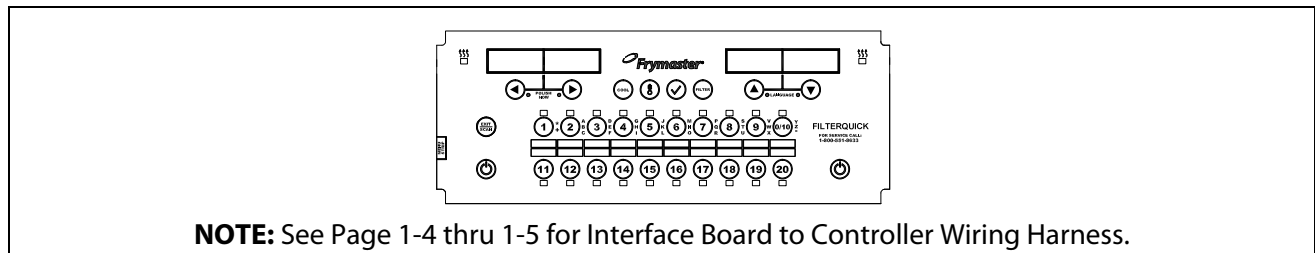

ITEM	PART #	COMPONENT
√	8263301	Controller, FilterQuick™
*	8263346	Software Kit, SD Card
*	8262458	Speaker SMT
*	2601264	Bezel Two Position (Used for 2, 4 and 5 battery) <b>Used with the push button</b>
*	2601265	Bezel Three Position (Used for 3 and 5 battery) <b>Used with the push button</b>
*	2600635	Bezel 2, 4 and 5 battery <b>Used with the knob</b>
*	2600684	Bezel 3 and 5 battery <b>Used with the knob</b>

\* Not illustrated.

√ Recommended parts.

### 1.5.5 Control Panel Frames and Push Pull Rod Assembly

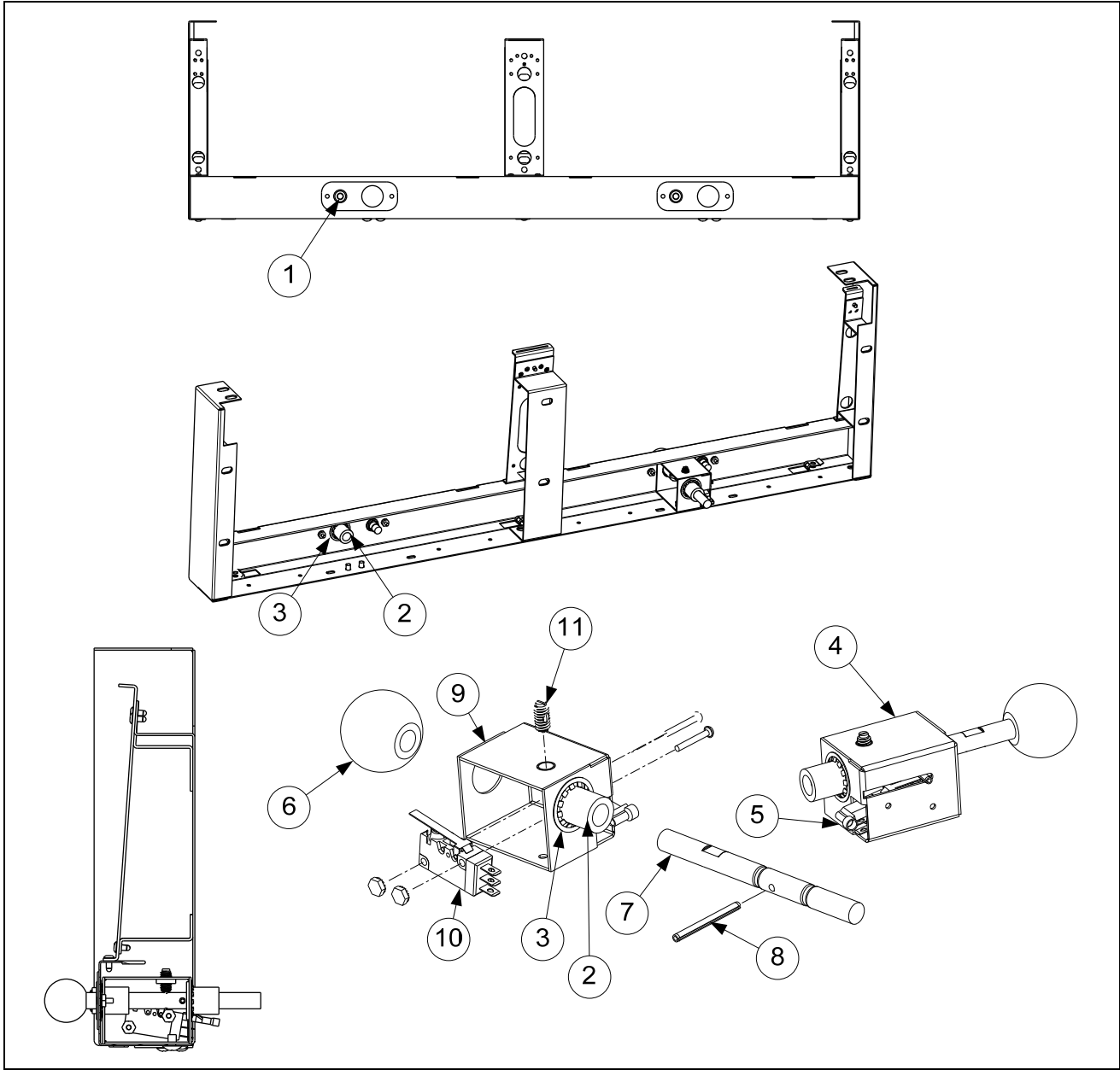

ITEM	PART #	COMPONENT
1	1085672	Harness, FilterQuick Drain with Light
2	8104345	Bushing, 3/8" Shaft Flanged Sleeve Bronze
3	8091107	Ring, 5/8" External Slef Locking Retaining
4	1085731	Assembly, Rod Push Pull
5	8071942	Terminal, Flag
6	8104399	Knob, 1.375" Ball
7	8104360	Rod, Push Pull
8	8104362	Pin, 1/8" x 1.50 SS Slotted Spring
9	8238864	Support, Rod Push Pull
10	8074936	Microswitch, Gold Plated
11	8104397	Plunger, 1/4-20 SS Ball Nose Spring

### 1.5.6 Control Panel Frames and Push Button Assembly

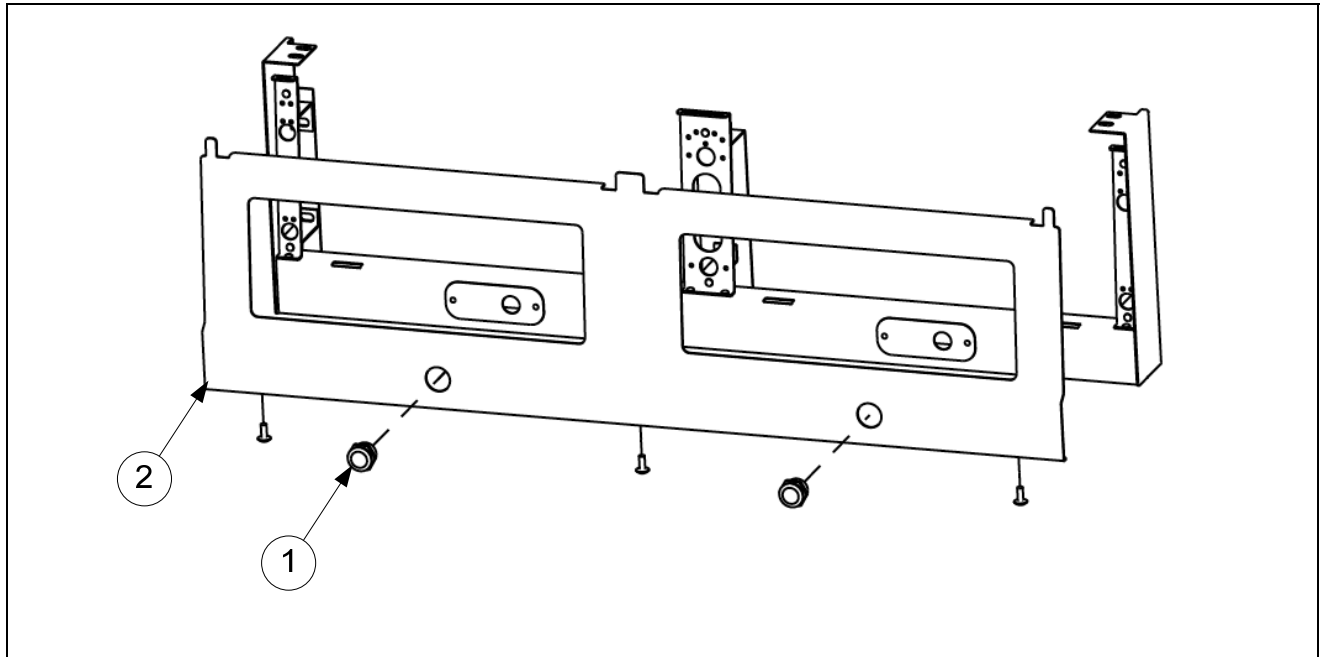

ITEM	PART #	COMPONENT
1	8075858	Switch, Push Button LED Blue Ring Light
2	2601264	Bezel, Fascia 2 position (2/4/5 Battery) with Button (shown)
	2601265	Bezel, Fascia 3 position (3/5 Battery) with Button (not shown)
*	8263280	Kit, FQ 2- Battery Conversion from Handles to Push Button
*	8263281	Kit, FQ 3- Battery Conversion from Handles to Push Button
*	8263282	Kit, FQ 4- Battery Conversion from Handles to Push Button
*	8263284	Kit, FQ 5- Battery Conversion from Handles to Push Button

\* Not illustrated.

## 1.6 Wiring

### 1.6.1 Controller, MIB, AIF, ATO Wiring Harnesses and Cord sets *(Refer to wiring diagram on page 1-59 in Service Manual 8197109.)*

ITEM	PART #	COMPONENT
*	8074546	Controller Communication <i>(used from Controller to Controller)</i>
*	8074547	AIF Communication/Power <i>(used from AIF to AIF and AIF to ATO)</i>
*	8074850	Communication/Power <i>(used from MIB to AIF)</i>
*	8075780	MIB Power/Pan Sw <i>(used from Transformer and Fltr Rly to MIB and Pan Sw)</i>
*	8075789	Harness, MIB -Bulk connector
*	8074655	FV/DV Harness RTD Extension 20" <i>(used from RTD to ATO Board)</i>
*	8074845	FV/DV Harness RTD Extension 28" <i>(used from RTD to ATO Board)</i>
*	8262706	FV/DV ATO/RTD Probe Kit
*	8074621	FV/DV Harness RTD Short <i>(used from RTD to ATO Board)</i>
*	8074771	ATO Power <i>(used from Transformer to ATO Board)</i>
*	1069544	ATO Power to Secondary ATO box (4 and 5 battery only)
*	8074671	ATO Pump/JIB Reset/Bulk Fresh Oil Solenoid Harness
*	8074843	ATO Pump/JIB Reset Harness Non-Bulk
*	1068977	Long Top-off Power <i>(used between Transformer Box to ATO Box) Domestic</i>
*	1081589	Long Top-off Power <i>(used between Transformer Box to ATO Box) CE and Export</i>
*	8074657	Jumper <i>(used on 4 and 5 battery ATO board plug J5 pin 7 and 8)</i>
*	8074573	Controller Locator Wire <i>(used from Controller to Interface Board) See wiring diagram 8051978 for locator pin positions.</i>
*	8074552	Communications Terminator <i>(used on Controller pin J6 and ATO board pin J10 to terminate network)</i>
*	8067742SP	Cord set, 120V Fryer and Motor with Ring Terminals
*	1060516	Cord set, 220-250V CE/Export Fryer and Motor with Ring Terminals
√	8074660PK	SMT Pin Service Repair Kit
√	2302345	SMT Pin Extractor

\* Not illustrated.

√ Recommended parts.

See page 1-26, 1-31, 1-39 and 1-51 in Service Manual 8197109 for Pin Positions.

**NOTE: See wiring diagrams in last section of this manual for wiring harness part numbers.**

## 1.6.2 Main Wiring Harnesses

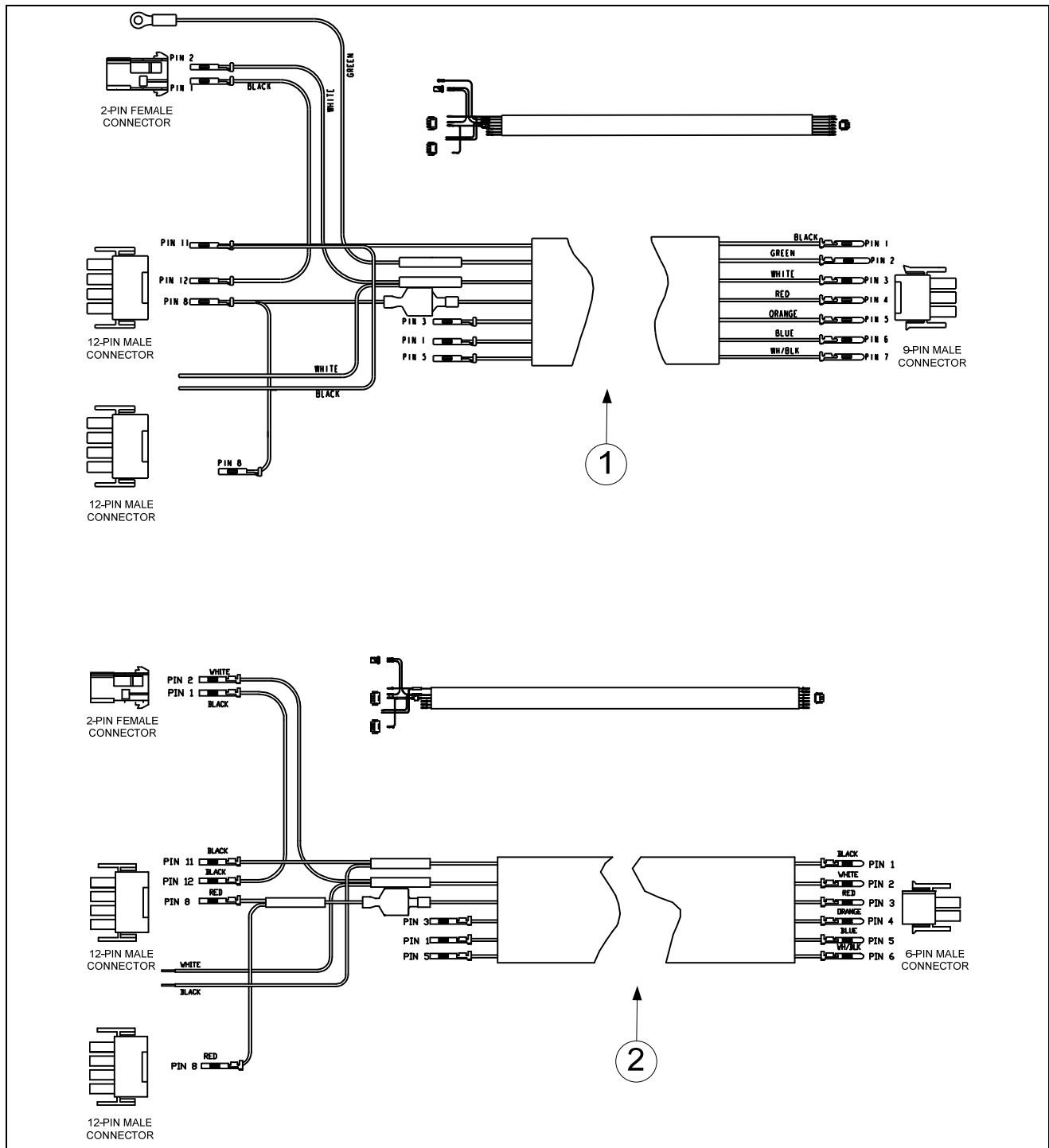

ITEM	PART #	COMPONENT
1	8075776	Main Wiring Harness Vat 1
	8122164	Main Wiring Harness Vat 1 <i>Australia</i>
2	8075779	Main Wiring Harness Vat 2-5
	8122165	Main Wiring Harness Vat 2-5 <i>Australia</i>

## 1.7 Frypots and Associated Components

### 1.7.1 Full-Vat Frypot Components

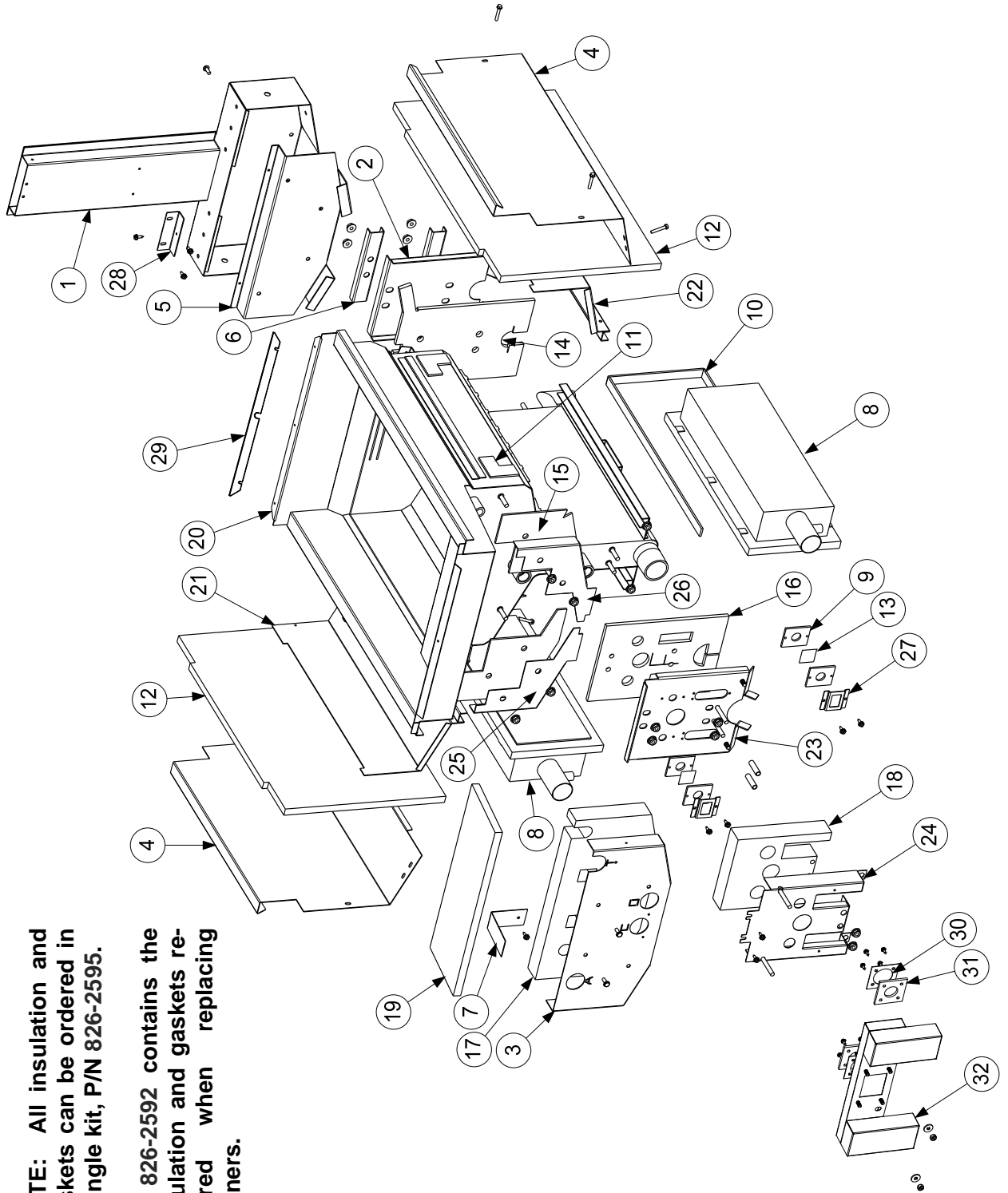

**NOTE:** All insulation and gaskets can be ordered in a single kit, P/N 826-2595.

Kit 826-2592 contains the insulation and gaskets required when replacing burners.



### 1.7.1 Full-Vat Frypot Components cont.

ITEM	PART #	COMPONENT
	1081752SP	Frypot Assembly Full-Vat (NAT/PRO)
	8262595	Insulation Kit, Complete Full-Vat
	8262592	Insulation Kit, Burner Full-Vat
1	1080925	Flue Assembly, Full-Vat
2	8238175	Back, Lower Full-Vat Combustion Chamber
3	2206529	Retainer, Full-Vat Upper Insulation (modified from shown, now one piece)
4	2207834	Retainer, Outer Frypot
5	2306960	Plate, FV Collector Mounting
6	2202851	Brace, FV Rear Insulation
7	2202920	Brace, Foam Deck Insulation
√ 8	8103435	Burner, Universal Replacement
9	8120356	Insulation, Burner Sight Glass
10	8160900	Insulation, Burner
11	8120706	Insulation, Upper Burner Rail
12	8121029	Insulation, Combustion Chamber Side
13	8140048SP	Glass, Burner Sight
14	8160837	Insulation, FV Rear Lower
15	8160731	Insulation, FV LH/RH Front Seal
16	8160976	Insulation, FV Lower Inner Front
17	8160733	Insulation, FV Front Upper
18	8160978	Insulation, FV Outer Front
19	8160746	Insulation, Foam Deck
20	8237644	Frypot, FV 30 439 SS <b>prior to 07/2014</b>
	8238932	Frypot, FV LOV™ 30 439 SS ) <b>after 06/2014</b>
21	8238193	Retainer, FV LH Upper Burner
22	8238194	Retainer, FV RH Upper Burner
23	8238571	Retainer, FV Front Combustion Insulation
24	8238574	Plenum, Full-Vat ( <b>use 8238590 for CE units and for Export Non-CE units</b> )
25	8242164	Front Upper Seal Weldment, FV LH
26	8242165	Front Upper Seal Weldment, FV RH
27	9001031	Retainer, Burner Sight Glass
28	9300818	Bracket, Flue to Pot
29	9004253	Strip, Fluecap Retainer
30	9001049	Retainer, Plenum Gasket
31	8160057	Gasket, Plenum
*	8160981	Gasket, Ignitor
*	9102474	Pot-to-Pot Gap Clip

\* Not illustrated.

√ Recommended parts.

## 1.7.2 Dual-Vat Frypot Components

**NOTE:** All insulation and gaskets can be ordered in a single kit, P/N 826-2596.

Kit 826-2593 contains the insulation and gaskets required when replacing burners.

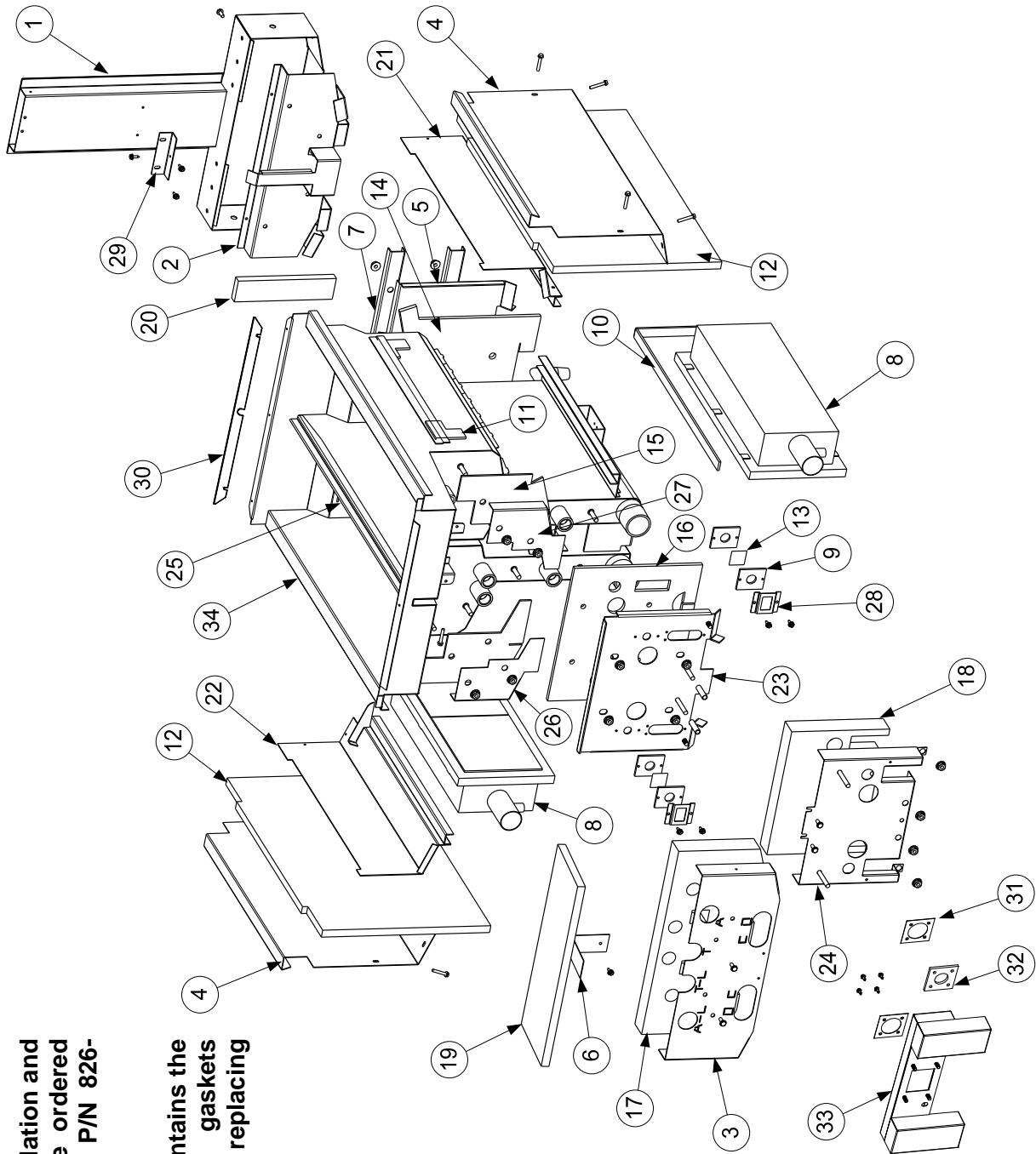

## 1.7.2 Dual-Vat Frypot Components cont.

ITEM	PART #	COMPONENT
*	1081753SP	Frypot Assembly Dual-Vat (NAT/PRO)
*	8262596	Insulation Kit, Complete Dual-Vat
√ *	8262593	Insulation Kit, Burner Dual-Vat
1	1080926	Flue Assembly, Dual-Vat
2	1067960	Plate Assembly, Dual-Vat Collector
3	2206530	Retainer, Dual-Vat Upper Insulation
4	2207835	Retainer, Dual-Vat Outer Frypot
5	8238176	Back, Dual-Vat Lower Combustion Chamber
6	2202920	Brace, Foam Deck Insulation
7	2202972	Brace, Dual-Vat Rear Insulation
√ 8	8103435	Burner, Universal Replacement
9	8120356	Insulation, Burner Sight Glass
10	8160900	Insulation, Burner
11	8120706	Insulation, Upper Burner Rail
12	8121029	Insulation, Combustion Chamber Side
13	8140048SP	Glass, Burner Sight
14	8160838	Insulation, Dual-Vat Rear Lower
15	8160741	Insulation, Dual-Vat LH/RH Front Seal
16	8160977	Insulation, Dual-Vat Lower Inner Front
17	8160743	Insulation, Dual-Vat Front Upper
18	8160979	Insulation, Dual-Vat Outer Front
19	8160746	Insulation, Foam Deck
20	8120688	Insulation, Flue Collection
21	8238196	Retainer, Dual-Vat RH Upper Burner
22	8238195	Retainer, Dual-Vat LH Upper Burner
23	8238578	Retainer, Dual-Vat Front Insulation
24	8238576	Retainer, Dual-Vat Outer Front
25	8241796	Riser W/A Dual-Vat Pot
26	8242166	Dual-Vat LH Upper W/A Seal
27	8242167	Dual-Vat RH Upper W/A Seal
28	9001031	Retainer, Sight Glass
29	9300818	Bracket, Flue to Pot
30	9004253	Strip, Fluecap Retainer
31	9001049	Retainer, Plenum Gasket
32	8160057	Gasket, Plenum
*	8160981	Gasket, Ignitor
33	8238573	Plenum, Dual-Vat <b>(use 8238589 for CE units and for Export Non-CE units)</b>
34	8237645	Frypot, Dual-Vat 30 439 <b>prior to 07/2014</b>
	8238942	Frypot, Dual-Vat LOV™ 30 439 SS <b>after 06/2014</b>
*	9102474	Pot-to-Pot Gap Clip

\* Not illustrated.

√ Recommended parts.

### 1.7.3 Frypot Assemblies and Associated Parts

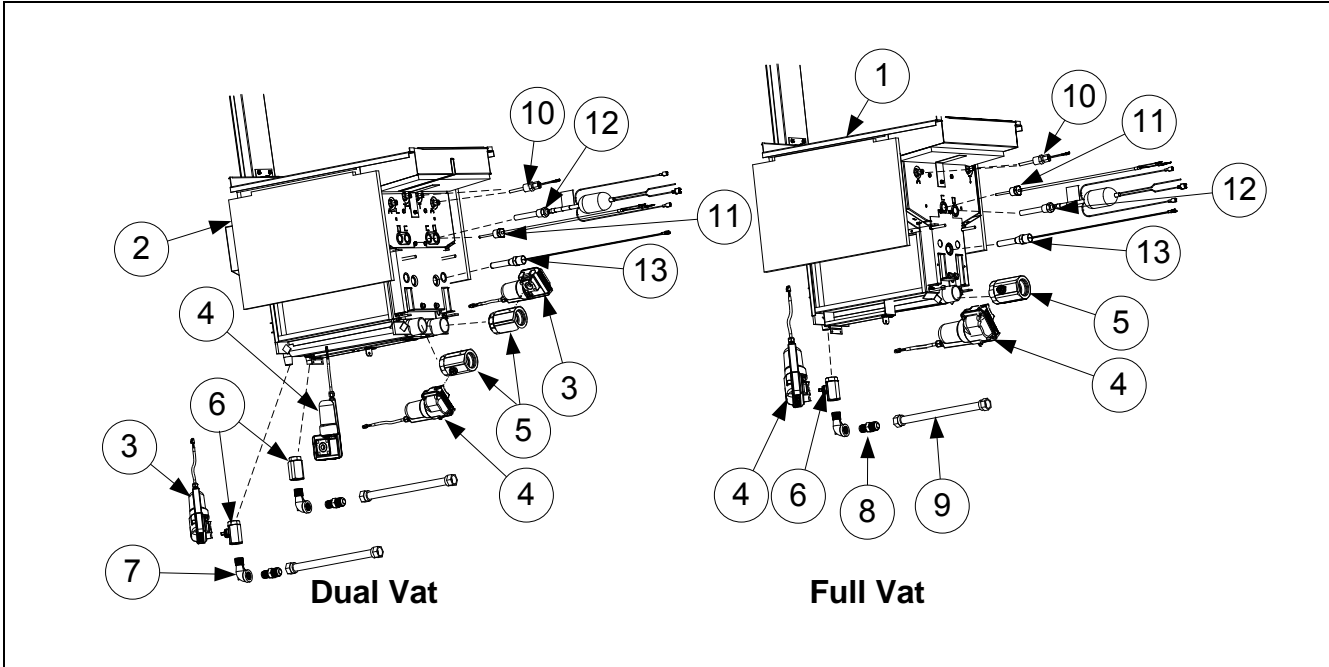

ITEM	PART #	COMPONENT
1	1081752SP	Frypot Assembly, Full-Vat Natural/Propane
2	1081753SP	Frypot Assembly, Dual-Vat Natural/Propane
√ 3	8074961	Actuator, Rotary 24VDC (#1) Blue
√ 4	8074962	Actuator, Rotary 24VDC (#2) Black
√ 5	8103755	Valve, 1¼ Drain Rotary Actuator
√ 6	8103754	Valve, ½ NPT Return Rotary Actuator
7	8130062	Elbow, Street ½" 90° BM
8	8101668	Adaptor, Male 5⁄8" OD x ½"
9	8101055	Flexline, 5⁄8" OD x 11.50" Long
√ 10	8262706	Probe, RTD AIF/ATO Kit
√ 11	8263196	Probe, Temperature Kit
√ 12	8074815	Sensor Assy, Oil 120V
	8074947	Sensor Assy, Oil 220V
	8074935	Sensor Assy, Oil 230V
	8074942	Sensor Assy, Oil 240V and 250V
√ 13	8261177	Thermostat Assembly, HE High-Limit 425°F/218°C Standard

√ Recommended parts.

## 1.8 Oil Return Manifolds

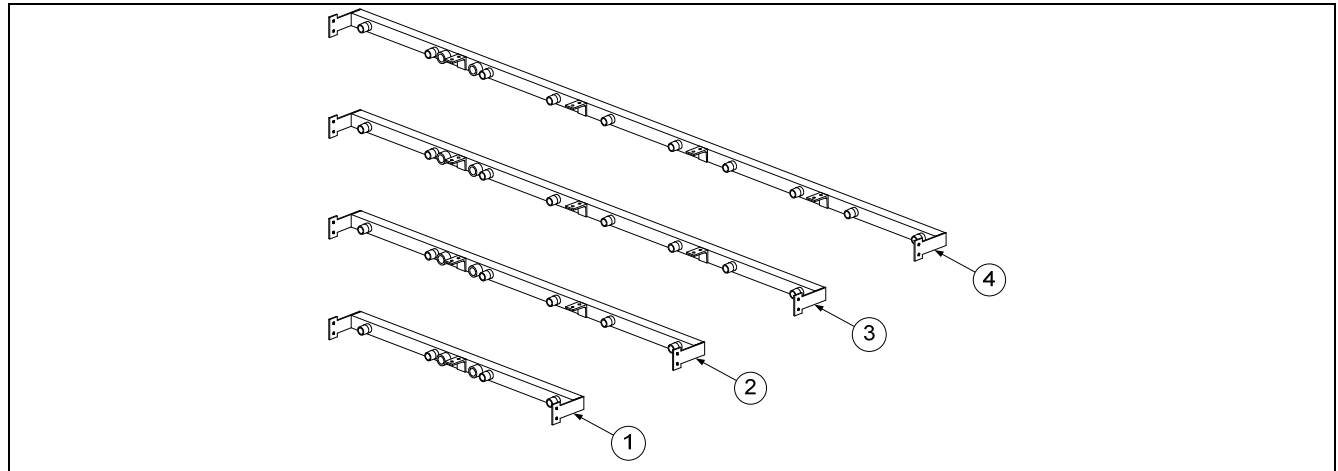

ITEM	PART #	COMPONENT
1	8103275	Manifold, Two-Station Fryer
2	8103245	Manifold, Three-Station Fryer
3	8103368	Manifold, Four-Station Fryer
4	8103824	Manifold, Five-Station Fryer
*	8130907	Cap, 15/16" Valve

\* Not illustrated

## 1.9 Return Valve

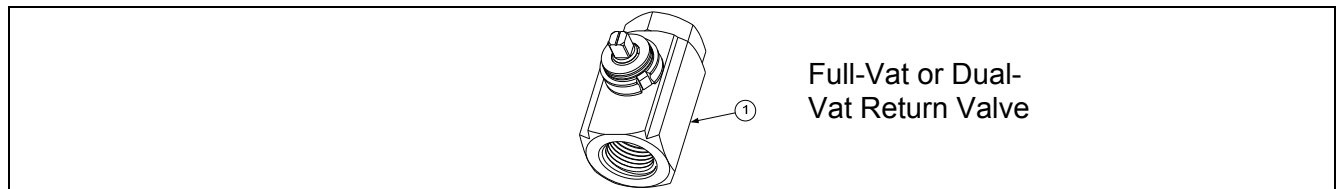

ITEM	PART #	COMPONENT
1	8103754	Valve, 1/2" NPT Rotary Actuator

## 1.10 Gas Supply and Combustion System Components

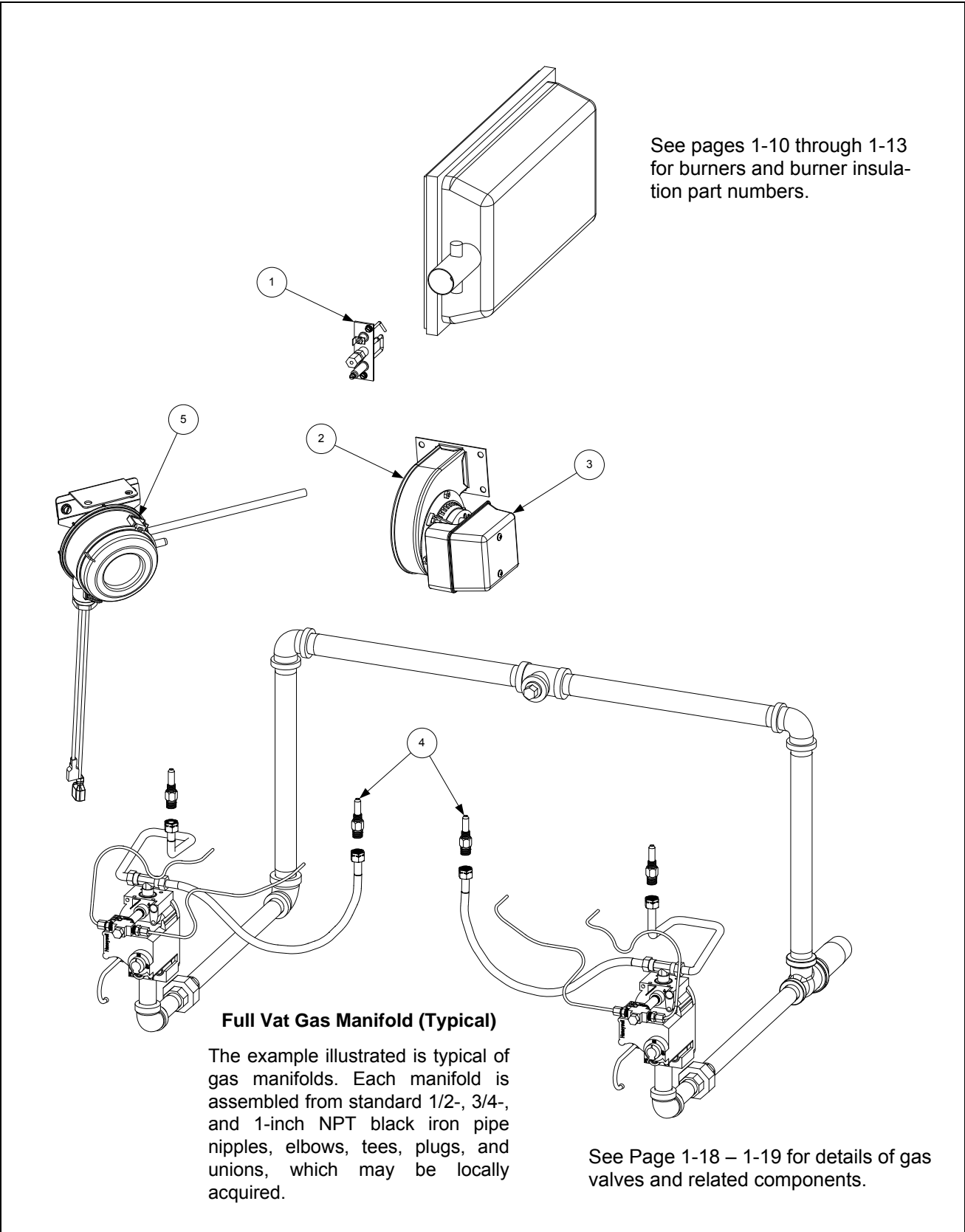

## 1.10 Gas Supply and Combustion System Components cont.

ITEM	PART #	COMPONENT
√ 1		Ignitor
	8263053	Natural Gas (G20, G25) (includes gasket 8160981, which may be ordered separately)
	8262994	Propane (G30, G31) (includes gasket 8160981, which may be ordered separately)
√ 2		Blower Assembly, Combustion Air (includes harness and Item 3)
	1062997SP	115V 50/60 Hz (Right)
	1062999SP	100V 50/60 Hz (Right)
	1083307SP	220V 60 Hz (Right)
	1062998SP	208-240V 50/60 Hz (Right) Non-CE International
	1082360SP	230V 50Hz CE FV Australia
	1082361SP	230V 50Hz (Right) CE DV Australia
	1063001SP	230V 50/60 Hz CE (Right) CE (Wide Body)
3	8160554	Cover, Blower Motor (component of all blowers listed above)
*	8068806SP	Harness Assembly, Blower Motor (component of all blowers listed above)
4		Orifice, Burner
		<b>**NPT Threads</b>
	8103977	1.88mm 75% Butane/25% Butane (Standard Elevation)
**	8103865	1.95mm Propane/Butane (G30, G31) Australia Only
**	8103860	2.05 mm Propane/Butane (G30, G31) (0-4999 Ft, 0-1524 M)
**	8103863	2.10 mm Propane/Butane (G30, G31) (5000-9000 Ft, 1525-2743 M)
**	8103867	2.84mm Natural Gas (G20, G25) Australia Only DV
**	8103866	2.92mm Natural Gas (G20, G25) Australia Only FV
**	8103864	3.18 mm Natural Gas (G20, G25) (0-4999 Ft, 0-1524 M) CE
**	8103861	3.26 mm Natural Gas (G20, G25) (0-4999 Ft, 0-1524 M)
**	8103862	3.40 mm Natural Gas (G20, G25) (5000-9000 Ft, 1525-2743 M)
**	8263278	Conversion Kit, Natural Gas FV (G20, G25) to Propane/Butane(G30,G31) Non-CE
**	8263279	Conversion Kit, Natural Gas DV (G20, G25) to Propane/Butane(G30,G31) Non-CE
**	8262967	Conversion Kit, Propane/Butane FV(G30, G31) to Natural Gas (G20,G25) Non-CE
**	8262968	Conversion Kit, Propane/Butane DV(G30, G31) to Natural Gas (G20,G25) Non-CE
**	8262969	Conversion Kit, Nat Gas FV (G20, G25) to Prop/Butane(G30,G31) Aust Non-CE
**	8262970	Conversion Kit, Nat Gas DV (G20, G25) to Prop/Butane(G30,G31) Aust Non-CE
**	8262971	Conversion Kit, Prop/But FV(G30, G31) to Natural Gas (G20,G25) Aust Non-CE
**	8262972	Conversion Kit, Prop/But DV(G30, G31) to Natural Gas (G20,G25) Aust Non-CE
**	8263278	Conversion Kit, Nat Gas (G20, G25) to Prop/Butane(G30,G31) CE
**	8262976	Conversion Kit, Prop/But (G30, G31) to Natural Gas (G20,G25) CE
√ 5	1083346	Switch, Air Pressure Assembly FV (8122226 switch alone) CE and Export
√	1081455SP	Switch, Air Pressure Assembly DV (8122141 switch alone) CE and Export
√	1083542	Switch, Air Pressure Assembly FV (8122226 switch alone) Australia
√	1083541	Switch, Air Pressure Assembly DV (8122141 switch alone) Australia

\* Not illustrated.

√ Recommended parts.

## 1.11 Gas Valves and Associated Components

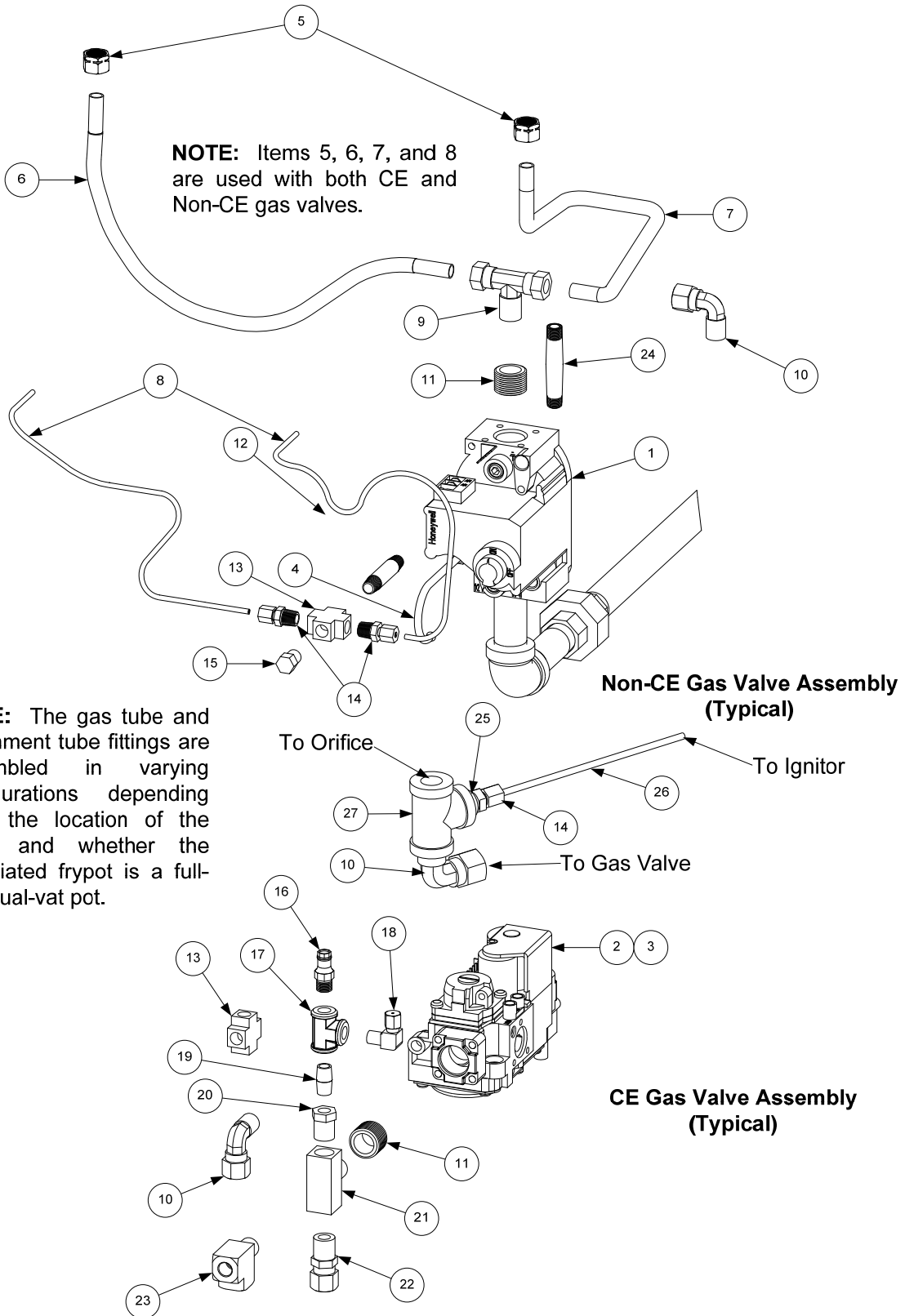



## 1.11 Gas Valves and Associated Components cont.

ITEM	PART #	COMPONENT
√ 1		Valve, Non-CE Gas
	8261122	Natural Gas (G20, G25)
	8261120	Kit Natural Gas w/ flexlines and hardware
	8261123	Propane Gas (G30, G31)
	8261121	Kit, Propane Gas w/ flexlines and hardware
√ 2	8101715	Valve, CE Gas (G20, G25, G30, G31)
*	8069678	Plug, Gas Valve CE
3	8101041	Accessory Kit (contains parts to adapt Item 2 to specific fryer configuration)
4	8100691	Tube, 1/8" Vent
5	8100494	Ferrule (Nut), Orifice
6	8101355	Gas Line, 3/8" OD X 15-inch SS Flexible
7	8101354	Gas Line, 3/8" OD X 12-inch SS Flexible
	8101353	Gas Line, 3/8" OD X 9-inch SS Flexible (Used on some split pots)
8	8110800	Tube, 1/8" OD X 12.5-inch Enrichment (cut and form to fit)
9	8130301	Tee, 1/4" Male NPT to 3/8" Tube
10	8130302	Elbow, 1/4" Male NPT to 3/8" Tube 90° (used on DV valve)
11	8130304	Bushing, 1/2" NPT to 1/4" NPT Flush Reducing
12	8130405	Nipple, 1/8" NPT X 2.00-inch Brass
13	8130378	Fitting, 1/8" NPT Cross
14	8130340	Adapter, 1/8" NPT to 1/8" Tube
15	8130154	Plug, 1/8" NPT Hex Head Pipe
16	8101176	Tap, 1/8" NPT Pressure
17	8130377	Tee, 1/8" NPT Female
18	8130354	Elbow, 1/8" NPT X 1/8" Tube Compression
19	8130016	Nipple, 1/8" NPT X Close
20	8101006	Bushing, 1/4" NPT to 1/8" NPT Reducing
21	8130495	Tee, 1/4" Male NPT to Female NPT
22	8101025	Connector, 1/4" Male NPT to 3/8" Tube
23	8101026	Tee, 1/4" Male NPT to Female NPT Street
24	8130700	Nipple, 1/4" NPT x 3.00-inch Brass
*	8130472	Nipple, 1/4" NPT x 2.50-inch Brass
*	8130471	Nipple, 1/4" NPT x 1.50-inch Brass
*	8130473	Nipple, 1/4" NPT x 4.00-inch Brass
25	8103147	Bushing, 3/4" OD x 1/2" ID NPT Flush
26	8103807	Tube, 1/8" OD X 6.5-inch Enrichment
*	8130507	Coupling, 1/4" NPT Brass
27	8130449	Tee, 1/4" NPT Brass

√ Recommended parts.

\* Not illustrated.

## 1.12 Filtration System Components

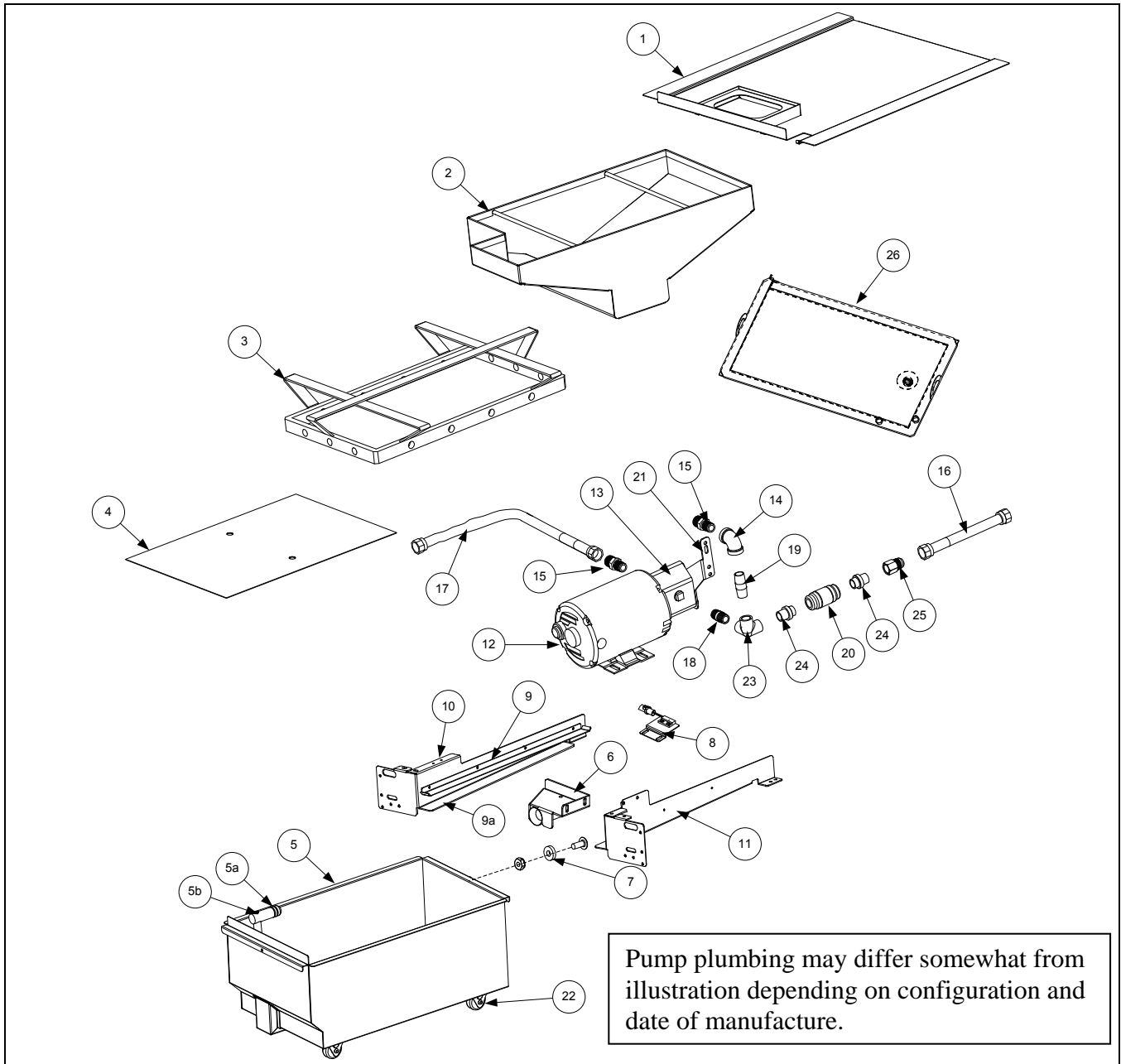

ITEM	PART #	COMPONENT
1	8238786	Lid, Filter Pan
2	8238626	Crumb Tray
3	8103289	Hold-Down Ring for Pad 11.20 x 19.10
4	8122025	Sana Grid Filter Screen
5	1085758SP	Pan, Filter with casters
	1086976SP	Pan, Filter Pan with casters ( <b>Only for use with Filter Leaf</b> )
√ 5a	8261392	O-Ring (Pkg. of 5; used with Item 5)
5b	8130568	Plug, 1/8" Socket Head Pipe (used with Item 5; two required)
6	8236458	Suction Tube
7	8103007	Magnet, Pull Ring

\* Not illustrated.

√ Recommended parts

## 1.12 Filtration System Components cont.

ITEM	PART #	COMPONENT
8	1085626	Assembly, Filter Pan Switch
√ *	1065876SP	Sensor, Magnet
9	2318372	Rail, Upper
9a	2308373	Rail, Lower
10	8238030	Support, Left Filter Pan
11	2208368	Support, Right Filter Pan (use 1082872 for 2- Battery)
√ 12		Motor and Gasket Kit
	8261785	100V 50/60 Hz
	8261712	115V 50/60 Hz
	8261756	208V 50/60 Hz
	8261270	220-240V 50/60 Hz
	8261755	250V 50/60 Hz
√ 13	8263191	Pump and Gasket Kit, 4 GPM
	8160093	Gasket, Pump/Motor
*	8091062	Cap Screw, 5/16"-18 4.00" NC Hex (Connects pump to motor.) (use 8090194 washer)
14	8130062	Elbow, 1/2" 90° BM
15	8101668	Adapter, 5/8" to 1/2" NPT Male
16	8101067	Flexline, 5/8" OD x 8.50-inches long Oil Return
17	8101369	Flexline, 17.50-inch Oil Return
18	8130087	Nipple, 1/2" x 1.50-inch NPT BM
19	8130298	Nipple, 1/2" x 2.00-inch NPT BM
20	8100667	Check Valve 1/2" NPT
21	2206191	Brace, Pump Motor
22	8104137	Caster, 2.00-inch
23	8130331	Elbow, 1/2" NPT with Side Outlet BM
24	8103738	Adapter, Check Valve Close
25	8101669	Adapter, Female 5/8" OD x 1/2"
26	8104492	Leaf Assy, Filter ( <b>Only for use with Filter Pan 108-6976SP</b> )
*	8071105	Heater Strip Assembly, 100120V 25W 18"
*	8071098	Heater Strip Assembly, 208-250V 25W 18"

\* Not illustrated. √ Recommended parts.

## 1.13 Filtration Electronic Components

### 1.13.1 MIB (Manual Interface Board) Assembly

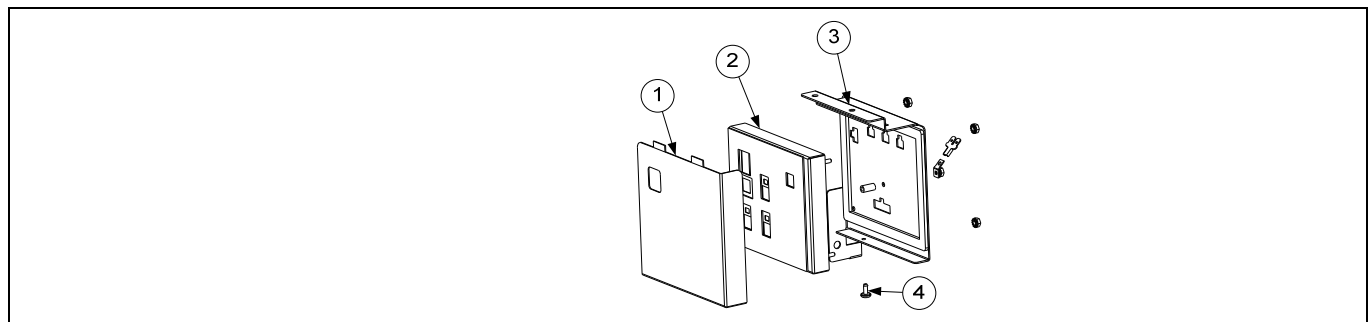

ITEM	PART #	COMPONENT
1	2206554	Cover, MIB
√ 2	1085723SP	Assembly, FilterQuick MIB Controller w/ Metalwork (use 8074481 for overlay)
*	8160819	Seal, MIB
3	2206661	Mounting Plate
4	8091021	Screw, 10x 3/8 Torx Pan

\* Not illustrated. √ Recommended parts.

### 1.13.2 AIF (Automatic Intermittent Filtration) Actuator Board Assembly

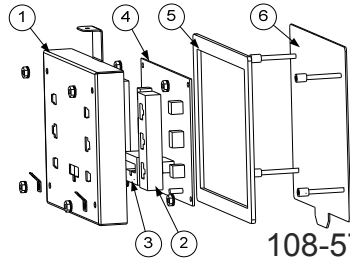

108-5721 AIF Actuator Board Assembly

ITEM	PART #	COMPONENT
√	1085721	AIF Assembly FilterQuick
1	8241991	Cover, Actuator Board
2	8160814	Gasket, Actuator Board
3	8160815	Gasket, Controller Board
4	1085720	Board, AIF Actuator FilterQuick
5	8160820	Seal, Actuator Board
6	1080097	Box, Actuator Stud

√ Recommended parts.

### 1.14 ATO (Auto Top-Off) Components

#### 1.14.1 JIB Cradle, JIB Box, JIB Cap/ Pick-Up Assembly and ATO Board Assemblies

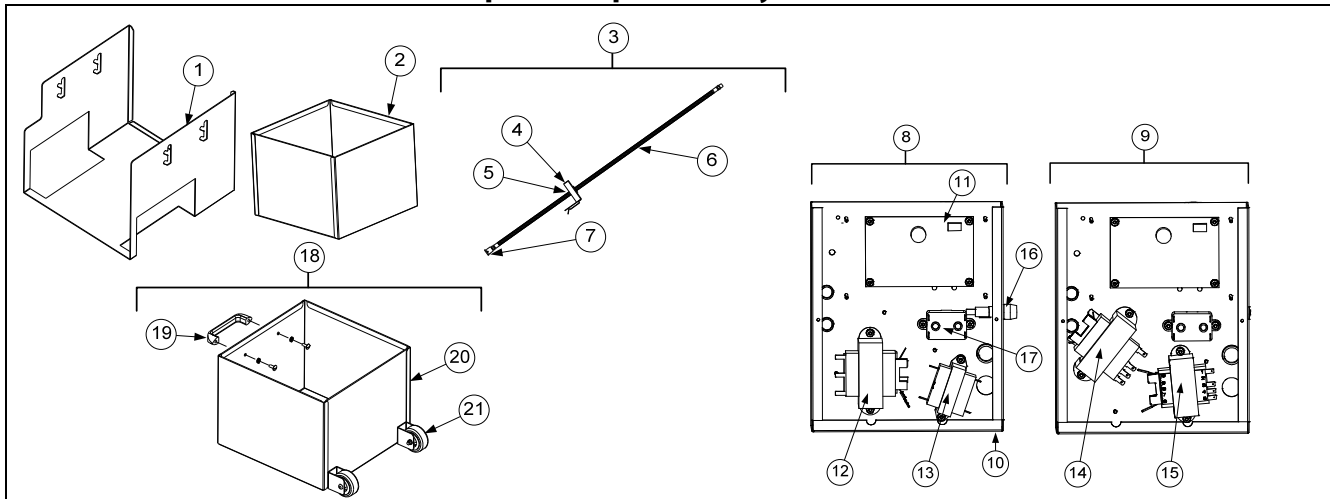

ITEM	PART #	COMPONENT
1	2600197	Cradle, JIB Gas
*	8090402	Screw, Thumb ¼-20 x ½"
2	8242298	Box, JIB
3	1082005SP	Cap, JIB Assembly (use 1082047 for Intl BIB)
4	1082001	Cap, JIB (use 1082002 for Intl. BIB)
5	8160870	Clamp
6	8103823	Hose, JIB
7	8237738	Tip Assembly, JIB Suction Hose
8	1085719	Box, Topoff Assembly FilterQuick 120V
9	1085764	Box, Topoff Assembly FilterQuick 208-240V
10	1085718	Box, Auto Top Off Board (use 2205679 for ATO Box Cover)
√	11	PCB Board, Automatic Top Off
√	12	Transformer, 100-120V/24V 62VA
√	13	Transformer, 120V 50/60-12V 20VA
√	14	Transformer, 208-240V/24V 50VA
√	15	Transformer, 208/230/240 -12V 30VA
16	8071321	Holder, Fuse AGC Panel Mount ¼"

ITEM	PART #	COMPONENT
√ *	8071597	Fuse, 3A Slow-Blow
√ 17	8070012	Relay, 18AMP 1/3 HP 24V Coil (Top off pump)
18	1086895	Box Assembly, JIB w/ Handle
19	8100180	Handle
20	8239145	Box, W/A JIB w/ handle
21	8122337	Caster, 2"

\* Not illustrated. √ Recommended parts.

**NOTE:** Top off boxes for vats 4 and 5 have either item 12 or item 14, both have item 11.

### 1.14.2 ATO Pump Assembly Non-Bulk

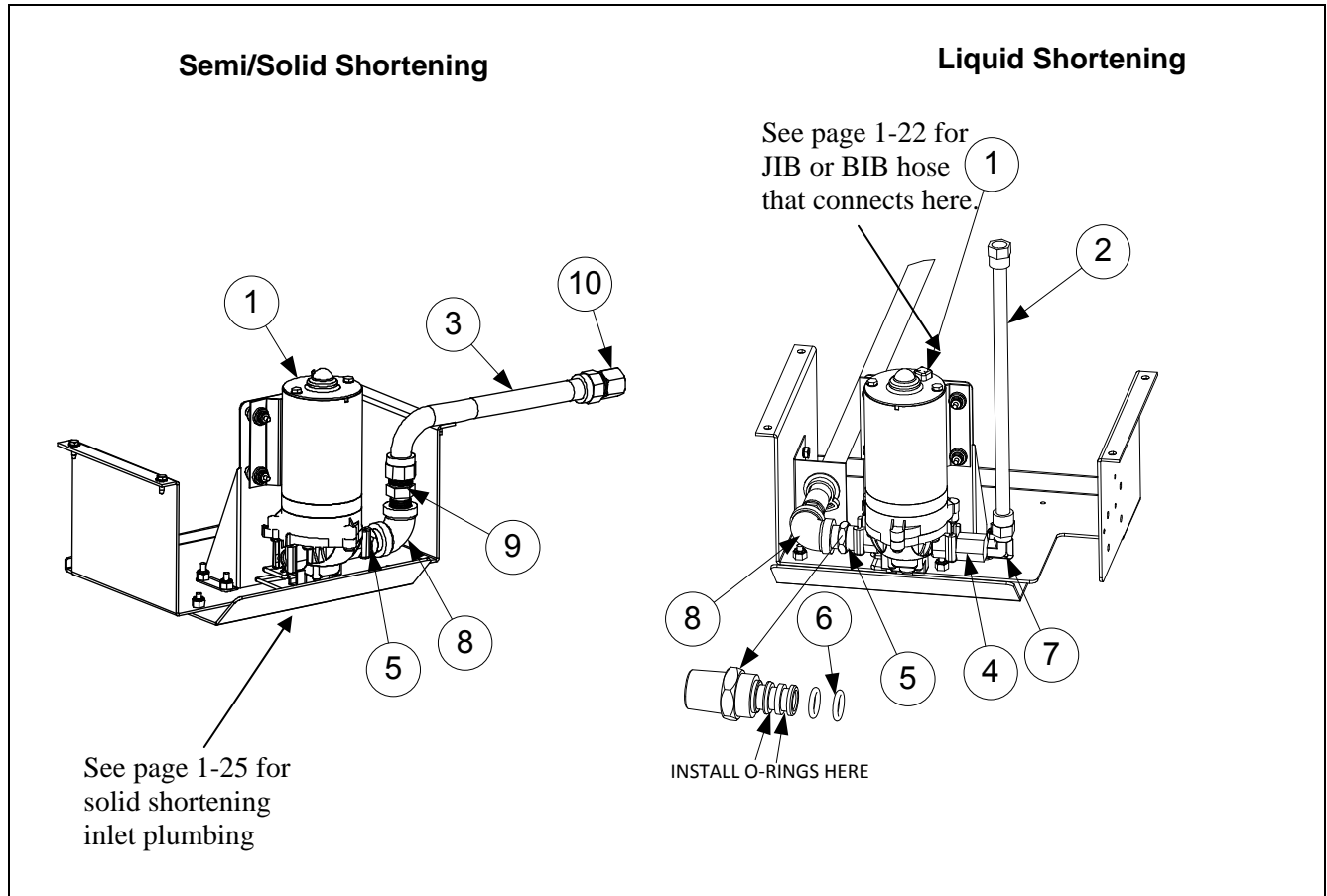

ITEM	PART #	COMPONENT
√ 1	1080639	Pump, Shurflo 24VAC (use 1085673 for CE)
2	8103263	Flexline, 1/2" OD x 36-inch (use 8103375 17-inch for 2-battery) (Out to top off manifold)
3	8101369	Flexline, 5/8" OD x 17.50-inch (use 8101069 29.50-inch for 2-battery)
4	1083403	Fitting, Shurflo Pump with female end (includes O-rings)
5	1082054	Fitting, Shurflo Pump with male end (includes O-rings)
6	8160782	O-Ring, Viton #111
7	8130940	Elbow, 1/4" NPT x 3/8" Flare
8	8130062	Elbow, 1/2" 90° BM
9	8101668	Adapter, 5/8" to 1/2" NPT Male
10	8101669	Adapter, Female 5/8" OD x 1/2"

√ Recommended parts.

### 1.14.3 ATO Pump Assembly Bulk

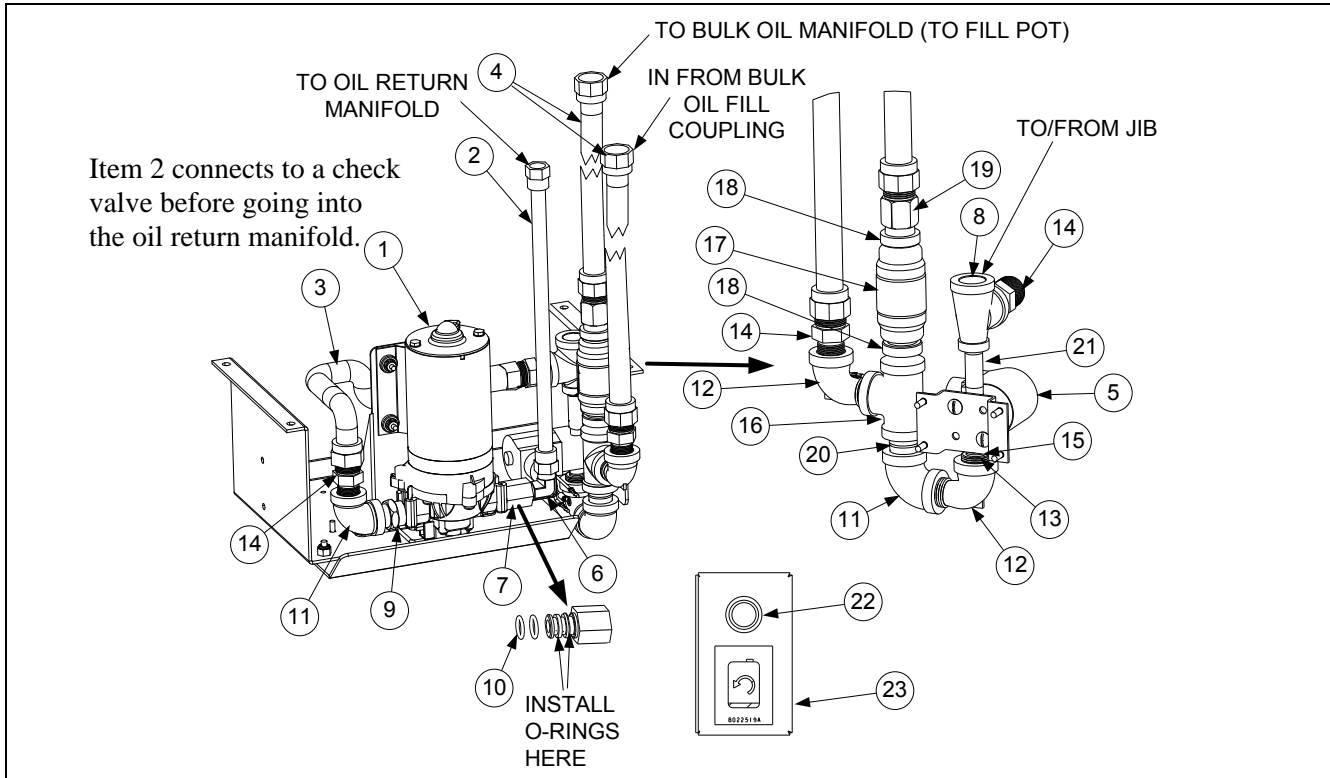

ITEM	PART #	COMPONENT
	1085790	Pump, Assy FQ230 Bulk ATO (use 1085791 for FQ330 bulk oil ATO)
√ 1	1080639	Pump, Shurflo 24VAC
2	8103263	Flexline, 1/2" OD x 36-inch (Out to oil check valve and to return manifold) 3, 4 and 5 vat
	8103375	Flexline, 1/2" OD x 17-inch (Out to oil check valve and to return manifold) 2 vat
*	8100667	Check valve, 1/2 NPT 1 PSI
3	8101055	Flexline, 5/8" OD x 11.50-inch (Inlet to Top Off Pump)
4	8101369	Flexline, 5/8" OD x 17.50-inch
5	1066830	Solenoid
6	8130940	Elbow, 1/4" NPT x 3/8 Flare
7	1083403	Fitting, Shurflo Pump with female end (includes O-rings)
8	8130530	Tee, Reducing 1/2" x 1/4" x 1/2" (JIB hose connects here)
9	1082054	Fitting, Shurflo Pump with male end (includes O-rings)
10	8160782	O-Ring, Viton #111
11	8130062	Elbow, 1/2" 90° BM
12	8130165	Elbow, Street 1/2" x 1/2" NPT 90° BM
13	8130304	Bushing, BM Flush
14	8101668	Adaptor, Male 5/8" OD x 1/2"
15	8130838	Nipple, 1/4" NPT BM Close
16	8130003	Tee, 1/2" x 1/2" x 1/2" BM
17	8103583	Check Valve 1/2" NPT 4 PSI
18	8103738	Adapter, Check Valve Close NPT
19	8101669	Adapter, Female 7/8" OD x 1/2"
20	8130022	Nipple, 1/2" x Close NPT BM
21	8130537	Nipple, 1/4" x 2.00" NPT
22	1069206	Assembly, JIB Reset Button Bracket
23	8074678	Switch, Momentary JIB Reset

\* Not illustrated.

√ Recommended parts.

### 1.14.4 Shortening Melting Unit

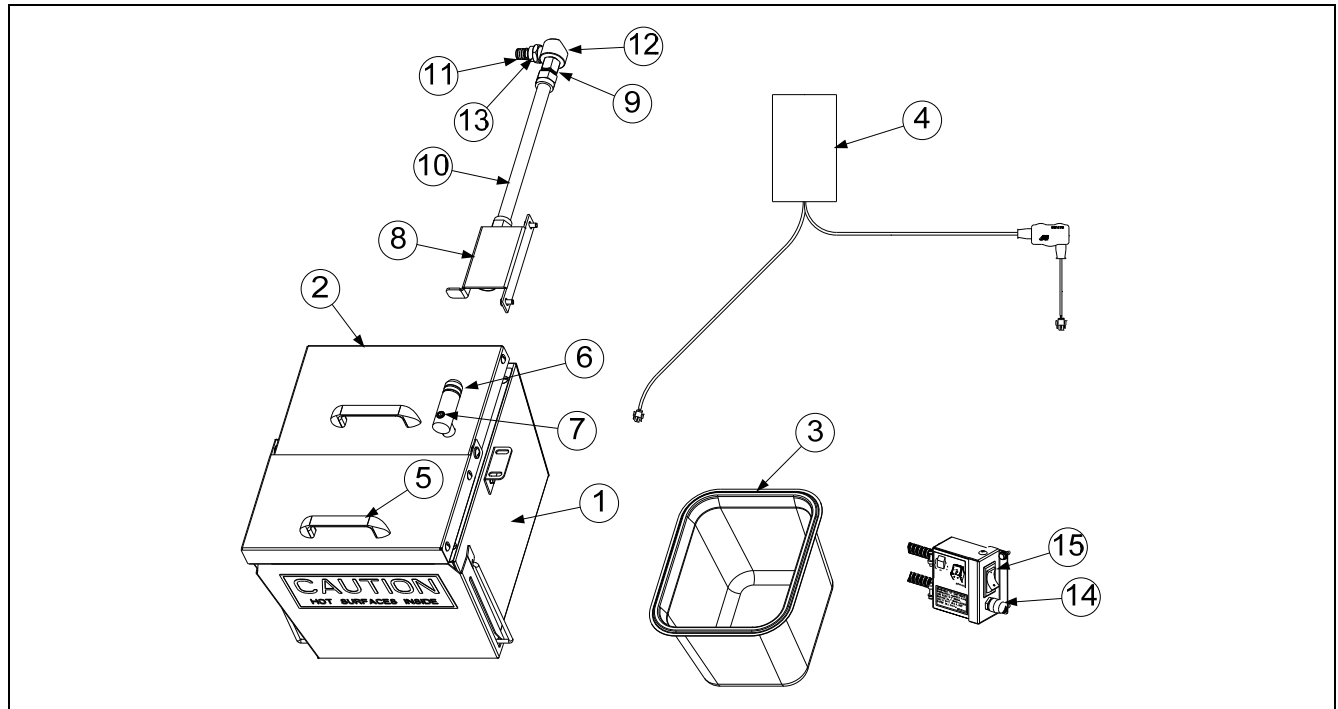

ITEM	PART #	COMPONENT
	1084497SP	Assy, Heated Shortening 120V (use 1084493 240V) (use 1085585 100V)
1	1084496	Box Assy, Heated Shortening 120V(use 1084492 240V)(use 1085584 100V)
2	1083774	Assembly, Solid Shortening Lid
3	8103957	Pan, Heated Shortening
4	8075321	Strips, Hot Box Heater with controller 120V
	8075268	Strips, Hot Box Heater with controller 240V
	8075732	Strips, Hot Box Heater with controller 100V
5	8100180	Handle
√ 6	8261392	O-Ring (Pkg. of 5)
7	8130568	Plug, 1/8" Socket Head Pipe
8	8238319	Bracket W/A, Shortening Suction 3 battery
9	8101669	Adaptor, Female 7/8" OD x 1/2"
10	8101055	Flexline, 5/8" OD x 11.5-inch
11	8160782	O-Ring, Viton #111
12	8130908	Adapter, 1/2" NPT 90°
13	1082054	Fitting, Shurflo Pump with male end (includes O-rings)
14	8071321	Holder, Fuse
√ *	8071555	Fuse 5 Amp 240V
√ *	8072799	Fuse 10 Amp 120V
15	8074036	Switch
*	8071105	Heater Strip Assembly, 120V, 25W 18"
*	8071420	Heater Strip Assembly, 120V, 25W 36"
*	8071472	Heater Strip Assembly, 120V, 40W 56"
*	8071098	Heater Strip Assembly, 240V, 25W 18"
*	8071419	Heater Strip Assembly, 240V, 45W 36"
*	8071473	Heater Strip Assembly, 240V, 70W 56"
*	8071915	Heater Strip Assembly, 100V, 25W 18"
*	8071917	Heater Strip Assembly, 100V, 40W 56"

\* Not illustrated.

√ Recommended parts.

## 1.15 Bulk Oil System Components

### 1.15.1 Bulk Dispose Waste Valve and Test Box

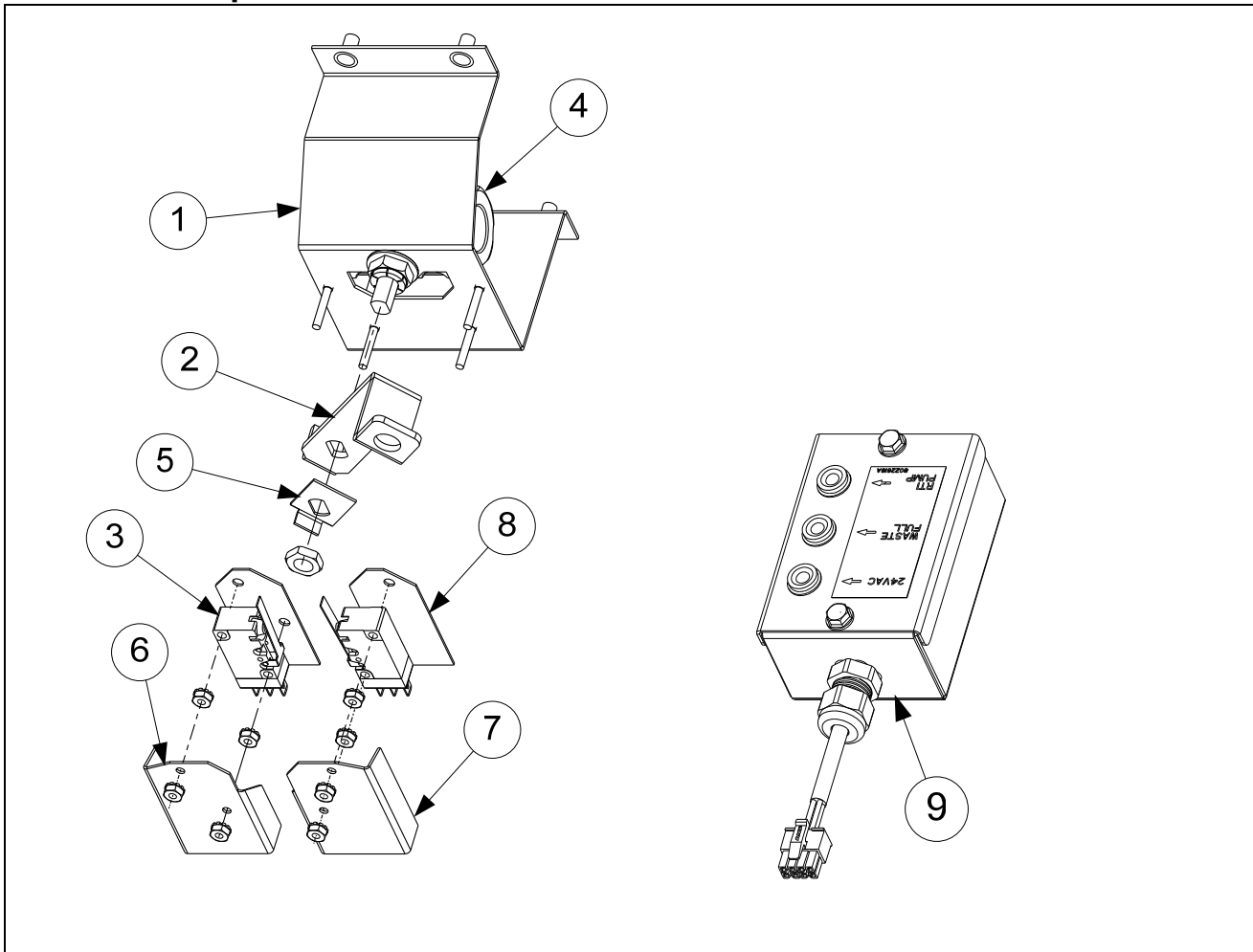

ITEM	PART #	COMPONENT
	1086009	Valve, Bulk Dispose Waste FQ
1	1086008	Bracket, FQ Bulk Waste Valve
2	2205899	Handle, Bulk Waste Valve
3	8074936	Microswitch, Gold Sealed
4	8100278	Valve, 1/2" Ball
5	9002935	Retainer, Nut Return Valve
6	9012348	Cover, DV Safety Switch
7	9022348	Cover, DV Safety Switch
8	8160220	Insulation, RF Switch
9	1080716	Box, Bulk Test



## 1.15.2 Bulk Oil Manifold and Accessories

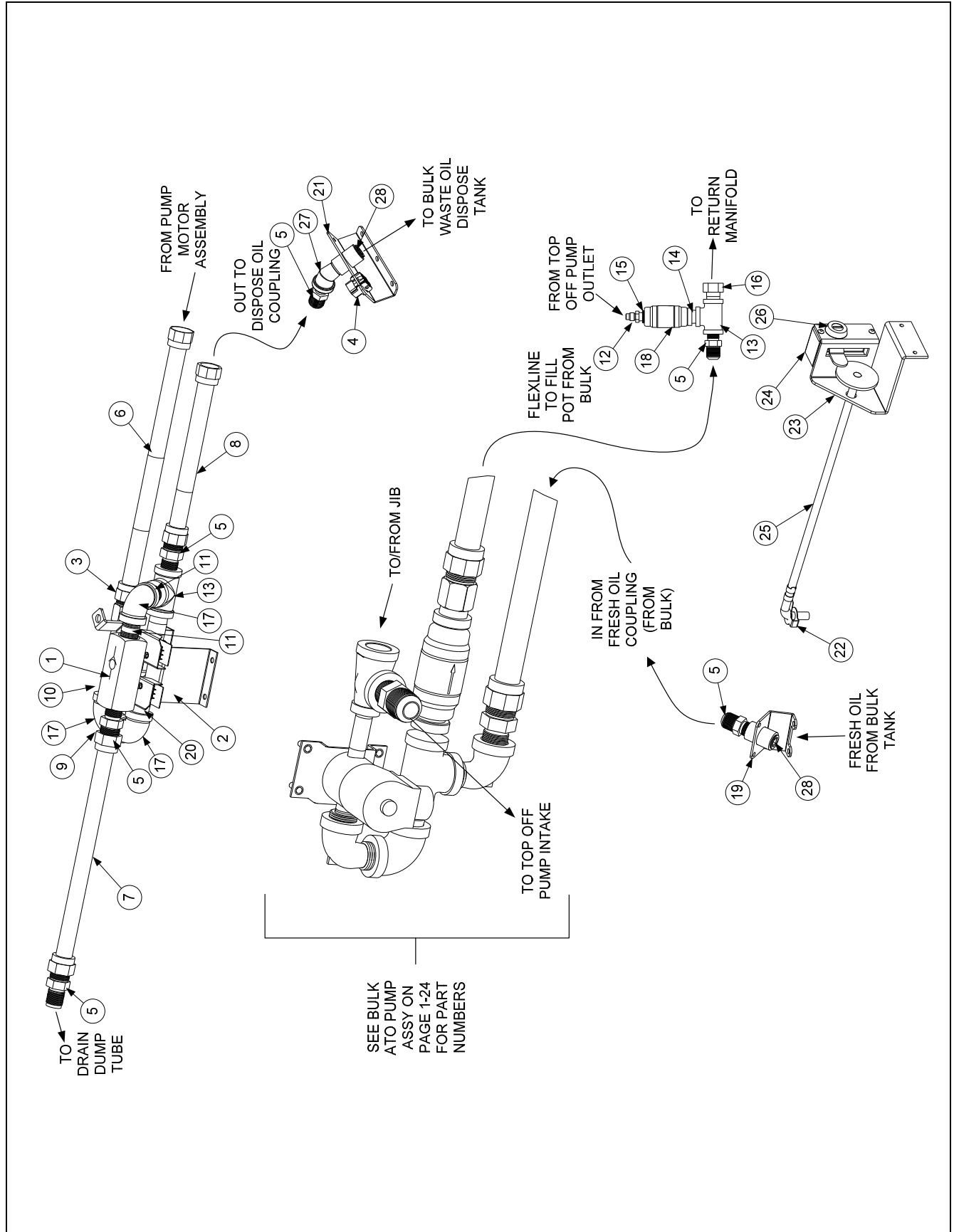

### 1.15.2 Bulk Oil Manifold and Accessories cont.

ITEM	PART #	COMPONENT
1	8103531	Valve, Check 20PSI
2	1086009	Valve, Bulk Waste Assembly (see page 1-26 for parts)
3	8101669	Adaptor, Male $\frac{5}{8}$ " OD x $\frac{1}{2}$ "
4	8075789	Harness, FilterQuick Gas Bulk – MIB connection
5	8101668	Adaptor, Male $\frac{5}{8}$ " OD x $\frac{1}{2}$ "
6	8101057	Flexline, $\frac{5}{8}$ " OD x 13-inches long
7	8101055	Flexline, $\frac{5}{8}$ " OD x 11.50-inches long
8	8101067	Flexline, $\frac{5}{8}$ " OD x 8.50-inches long
9	8130022	Nipple, $\frac{1}{2}$ " x Close NPT BM
10	8130251	Nipple, $\frac{1}{2}$ " x 4.50-inches NPT BM (not shown in illustration – connects between item 17 and item 3)
11	8130087	Nipple, $\frac{1}{2}$ " x 1.50-inch NPT BM
12	8103270	Fitting, $\frac{3}{8}$ " Flare x $\frac{1}{4}$ " NPT
13	8130003	Tee, $\frac{1}{2}$ " x $\frac{1}{2}$ " x $\frac{1}{2}$ " BM
14	8103738	Adaptor, Check Valve Close Nipple
15	8130304	Bushing, $\frac{1}{2}$ " x $\frac{1}{4}$ "
16	8103160	Adaptor, $\frac{1}{2}$ " NPT x 15/16"
17	8130062	Elbow, $\frac{1}{2}$ " BM 90°
18	8100667	Valve, Check $\frac{1}{2}$ " NPT 1 PSI Bulk Manifold
19	8237838	Bracket W/A, Gas Bulk Fresh Oil
20	8130298	Nipple, $\frac{1}{2}$ " x 2-inches NPT BM
21	8238827	Bracket W/A, FQ Gas Bulk Dispose
	1080686SP	Handle and Lock Assy, Gas Bulk
22	8090657	Clip, Clevis Right Rod End
23	2205656	Brace, Bulk Handle
24	2205657	Cover, Bulk Handle
25	8237208	Handle, Gas Bulk Waste Pull
26	8103587	Lock, Bulk Waste Handle (includes keys)
27	8130342	Elbow, Street 45° $\frac{1}{2}$ " NPT
28	8130463	Plug, $\frac{1}{2}$ " NPT

# 1.16 Basket Lift Assy and Associated Parts

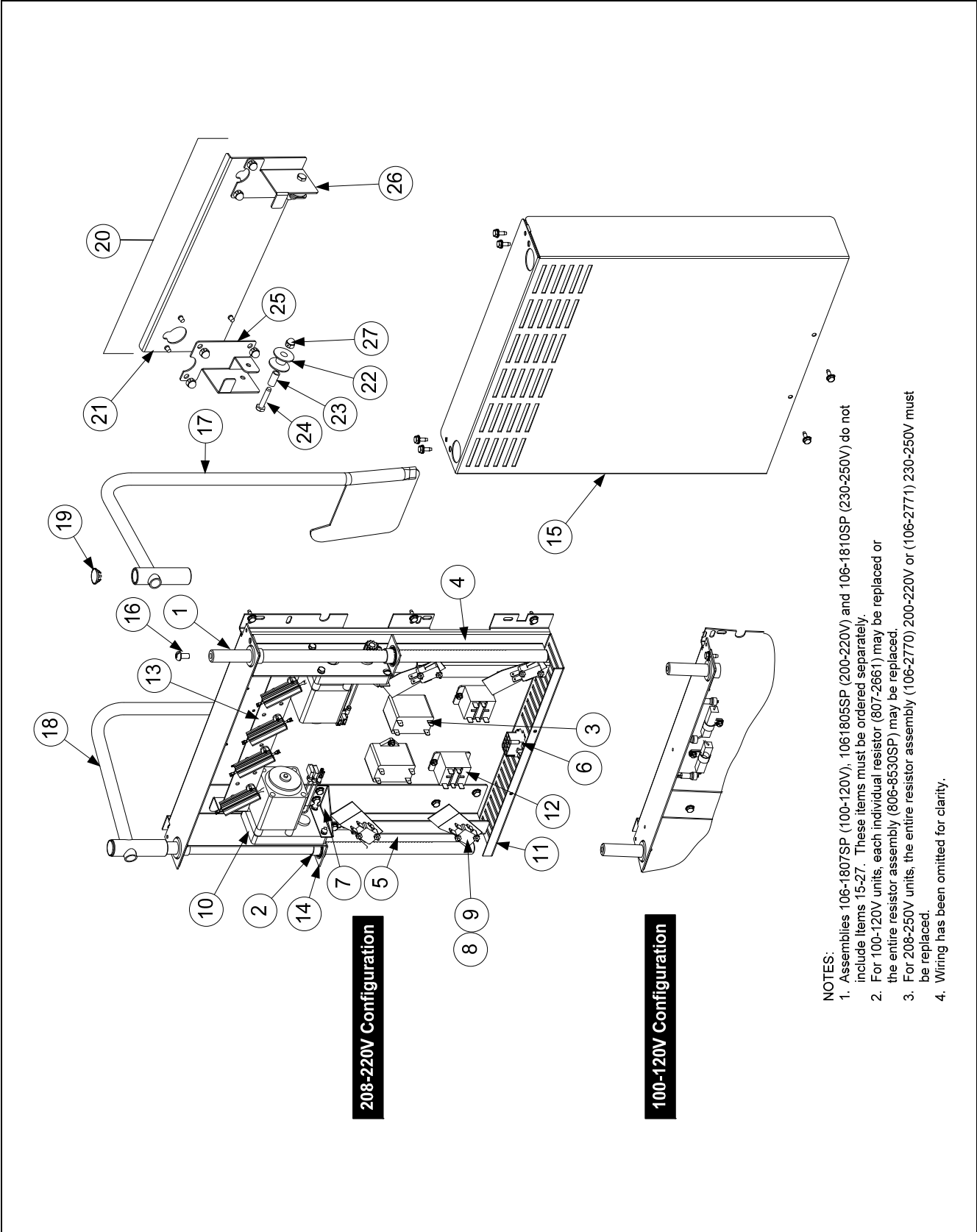

- NOTES:**
- 1. Assemblies 106-1807SP (100-120V), 1061805SP (200-220V) and 106-1810SP (230-250V) do not include items 15-27. These items must be ordered separately.
  - 2. For 100-120V units, each individual resistor (807-2661) may be replaced or the entire resistor assembly (806-8530SP) may be replaced.
  - 3. For 208-250V units, the entire resistor assembly (106-2770) 200-220V or (106-2771) 230-250V must be replaced.
  - 4. Wiring has been omitted for clarity.

### 1.16 Basket Lift Assy and Associated Parts cont.

ITEM	PART #	COMPONENT
		<b>Basket Lift Assemblies</b> (see <b>Note 1</b> in illustration)
	1061807SP	Basket Lift Assy, 100-120VAC w/Relay (Items 1-20) shown
	1061805SP	Basket Lift Assy, 200-220VAC w/Relay (Items 1-20) shown
*	1061810SP	Basket Lift Assy, 230-250VAC w/Relay (Items 1-20) not shown
1	8101012	Rod, Basket Lift
2	8130035	Bushing, Bronze
3	8072513	Capacitor, 12.5 $\mu$ Fd 330VAC
4	9018499	Chassis, Left Basket Lift
5	9028499	Chassis, Right Basket Lift
6	8070159	Connector, 12-Pin Female
7	9005529	Gusset, Basket Lift Motor
8	8120442	Insulation, Microswitch
9	8072572	Microswitch
10	8065964SP	Motor Assy, 208-240VAC Modular Basket Lift
11	2002942	Mount, Modular Basket Lift
12	8071683	Relay, 12VDC
13		Resistor Assy
	8068530SP	100-120V Modular Basket Lift (see <b>Note 2</b> in illustration)
	1062770SP	208-220VAC Modular Basket Lift
*	1062771SP	230-250VAC Modular Basket Lift
14	8090082	Ring, Bushing Retainer
15	9104776	Cover, Modular Basket Lift Rear S/S ( <b>Use 9004776 for Mild Steel</b> )
16	8090127	Screw, ¼-20 X ½" Slotted Round Head
17	8238015	Arm, Left Basket Lift
18	8238016	Arm, Right Basket Lift
19	8100179	Button, Plug
20	1082743SP	Roller Assy, Basket Lift
21	1082860	Mount, Basket Lift Roller
22	8100194	Roller, Basket Lift
23	8100374	Spacer, Basket Lift Roller
24	8090508	Bolt, ¼-20 X 1¼"
25	8237980	Guide, Basket lift Left
26	8238023	Guide, Basket lift Right
27	8090990	Nut, ¼-20 Cap
*	8241477	Tray, Drip Right
*	8241476	Tray, Drip Left
		<b>Wire Assemblies</b>
*	1083454	Harness, Gas BL Interface
*	8073695	Basket Lift Cable
*	WIR0482SP	Wire Bundle, 100-120VAC Basket Lift
*	1061822SP	For 100-120V Modular Basket Lift
*	1061804SP	For 208-250V Modular Basket Lift

\* Not illustrated.

## 1.17 Oil Quality Sensor (OQS) and Associated Parts

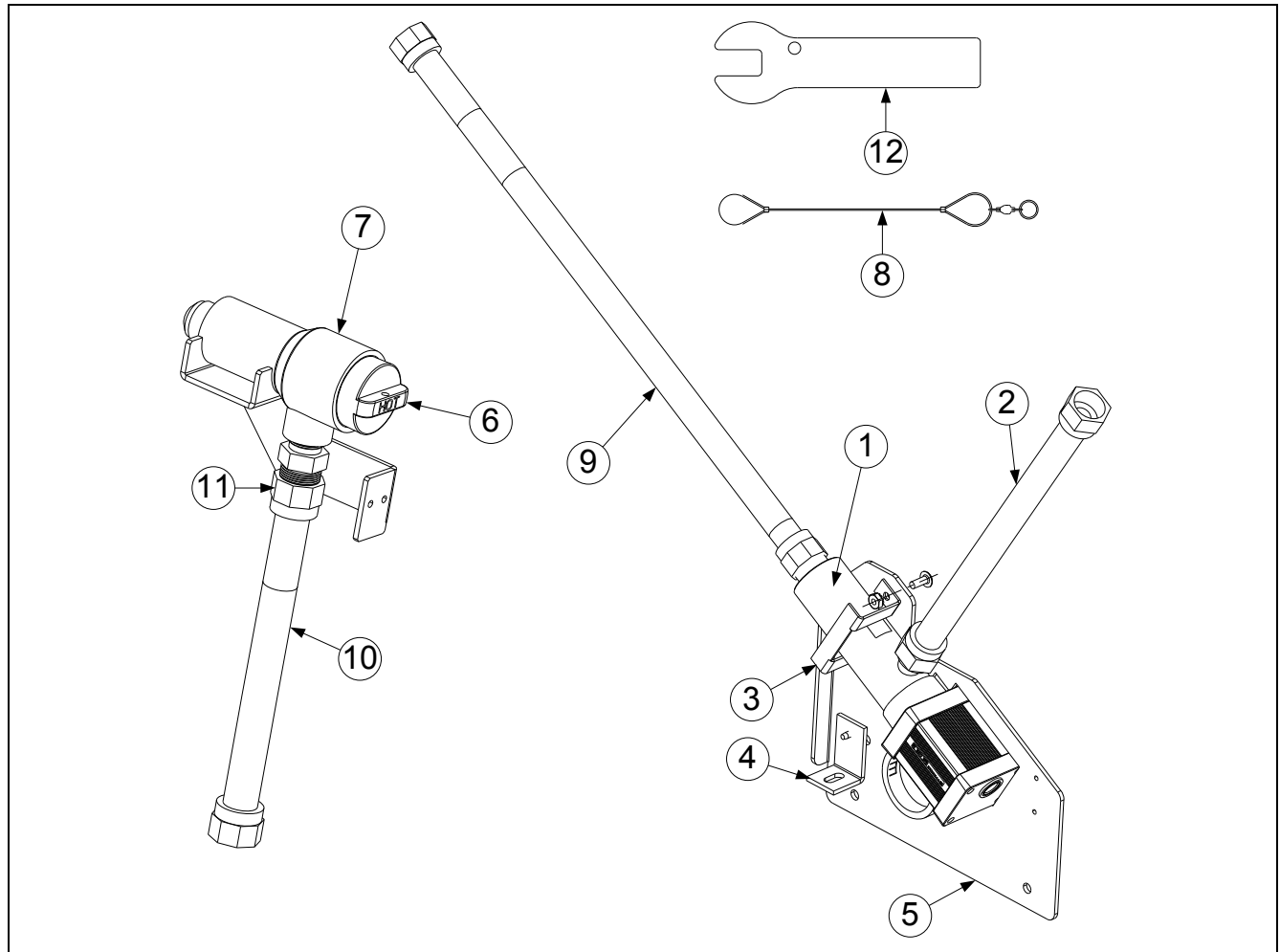

ITEM	PART #	COMPONENT
	8263291	Kit, OQS FilterQuick Gas 2-Battery (Kit to add to existing FilterQuick Gas Fryers)
	8263294	Kit, OQS FilterQuick Gas 3, 4 and 5 Battery (Kit to add to existing FilterQuick Gas Fryers)
1	8263292	Sensor, FilterQuick OQS Replacement
2	8101055	Flexline, 5/8" OD x 11.5-inch
3	2401385	Retainer, OQS Sensor FQ
4	2401386	Brace, OQS Sensor Mount
5	2401384	Mount, OQS Sensor FQ
6	8238335	Screen, Suction Line Filter
7	8238903	Body W/A, Pre-Filter Final EBRO BIGL230
8	8104167	Lanyard, In-Line Filter
9	8101369	Flexline, 5/8" OD x 17.50-inch
10	8101067	Flexline, 5/8" OD x 8.50-inch 2- Battery
	8101369	Flexline, 5/8" OD x 17.50-inch 3, 4 and 5-Battery
11	8101668	Adapter, 5/8" to 1/2" NPT Male
12	2401086	Wrench, Pre-Filter Cap

# 1.18 Simplified Wiring Diagrams

## 1.18.1 FilterQuick™ FQG30 Series Simplified Wiring with Push Buttons

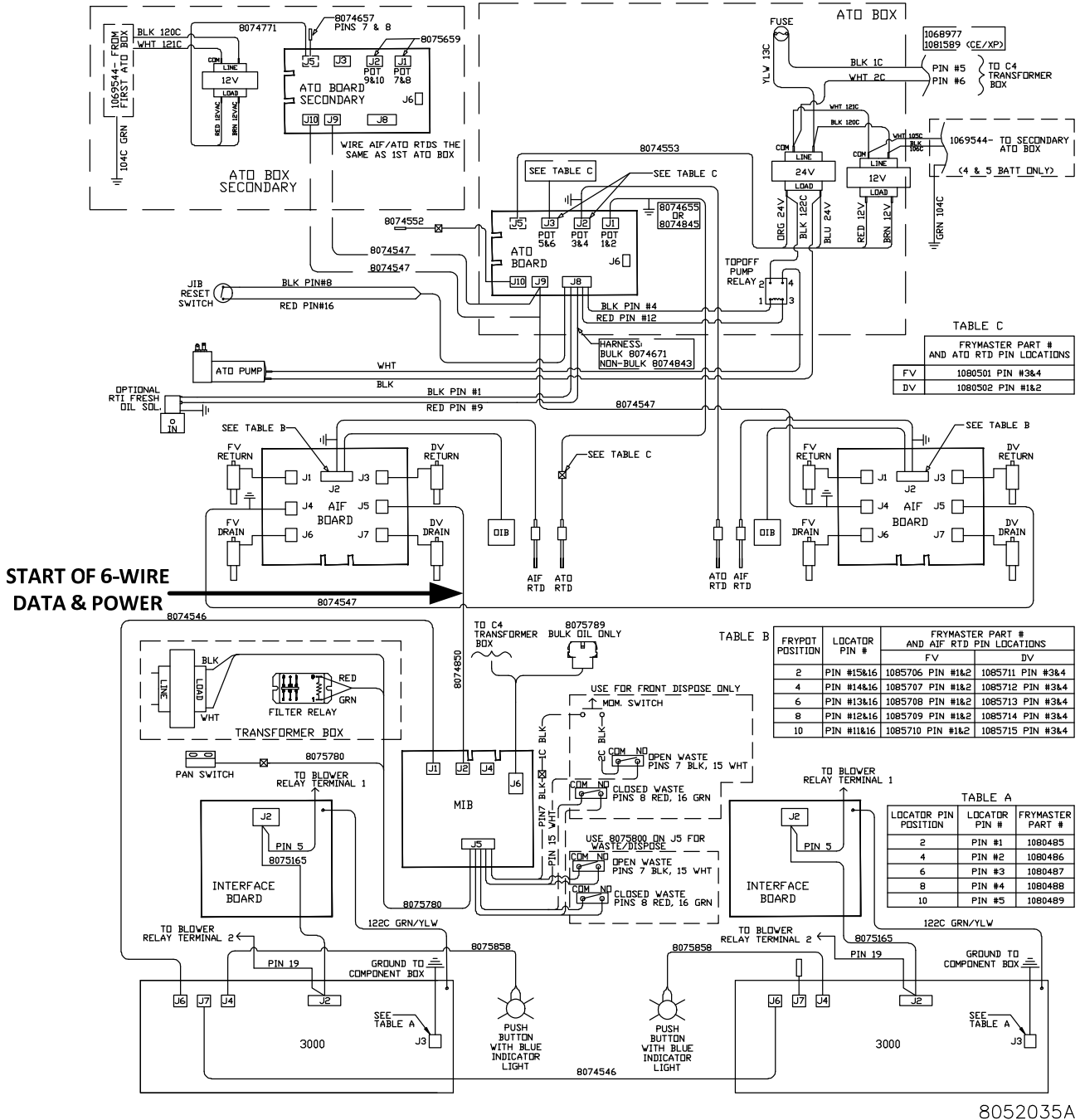

8052035A

# 1.18.2 FilterQuick™ FQG30 Series Simplified Wiring with Push Pull Handles

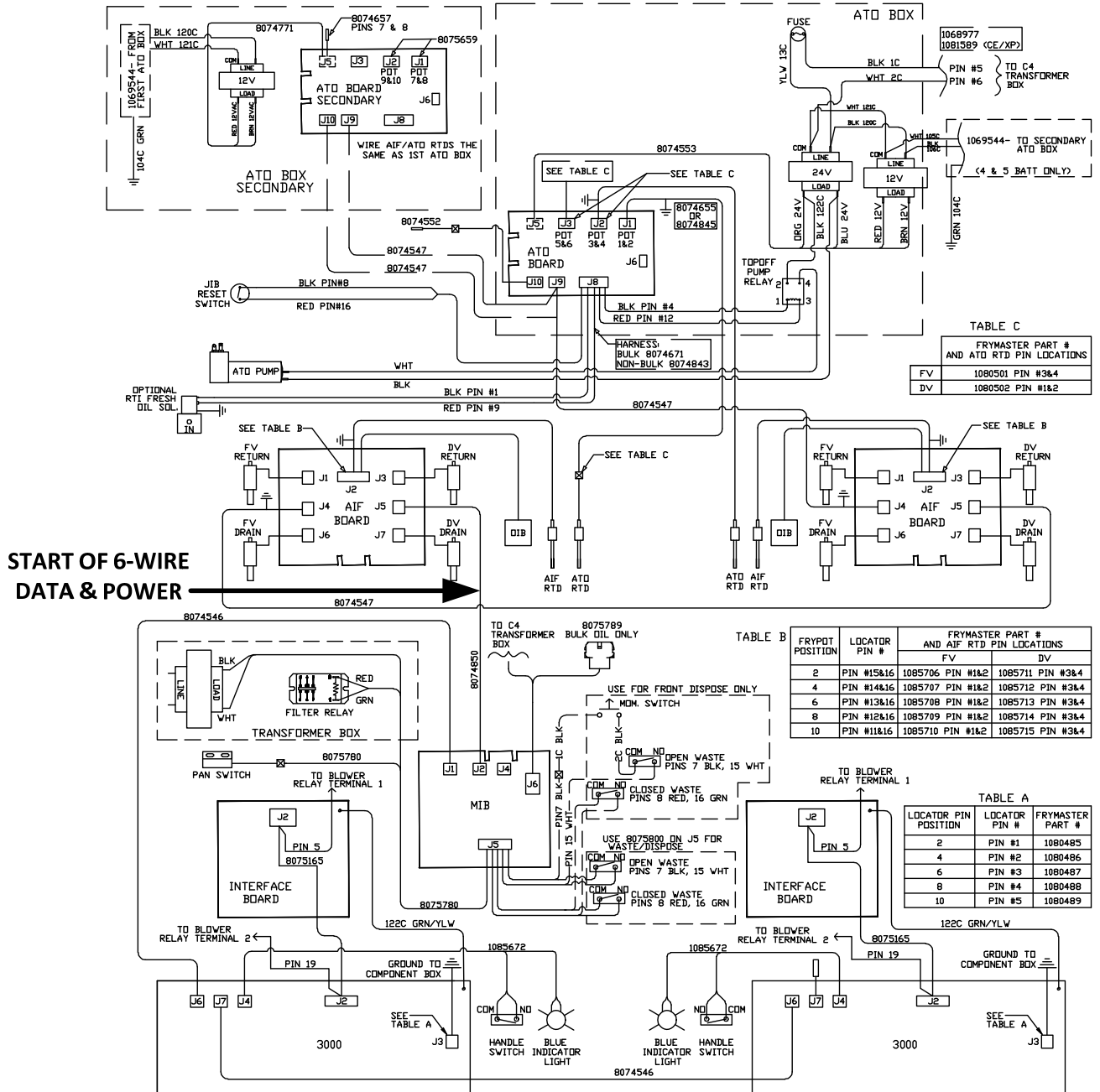





8051978D

**THIS PAGE INTENTIONALLY LEFT BLANK**



**WELBILT®**  
*Bringing innovation to the table***WWW.WELBILT.COM**

Welbilt provides the world's top chefs, and premier chain operators or growing independents with industry leading equipment and solutions. Our cutting-edge designs and lean manufacturing tactics are powered by deep knowledge, operator insights, and culinary expertise. All of our products are backed by KitchenCare® – our aftermarket, repair, and parts service.

 CLEVELAND  
CONVOTHERM® DELFIELD®  
FITKITCHEN™ FRYMASTER®  
GARLAND KOLPAK®  
LINCOLN MANITOWOC®  
MERCO® MERRYCHEF®  
MULTIPLEX®