



Application Series
Service and Parts Manual



Frymaster, a member of the Commercial Food Equipment Service Association, recommends using CFESA Certified Technicians.

24-Hour Service Hotline 1-800-551-8633

SEPTEMBER 2006

* 8196153 *

www.frymaster.com

Email: service@frymaster.com

IF, DURING THE WARRANTY PERIOD, THE CUSTOMER USES A PART FOR THE ENODIS EQUIPMENT OTHER THAN AN UNMODIFIED NEW OR RECYCLED PART PURCHASED DIRECTLY FROM FRYMASTER DEAN, OR ANY OF ITS AUTHORIZED SERVICE CENTERS, AND/OR THE PART BEING USED IS MODIFIED FROM ITS ORIGINAL CONFIGURATION, THIS WARRANTY WILL BE VOID. FURTHER, FRYMASTER DEAN AND ITS AFFILIATES WILL NOT BE LIABLE FOR ANY CLAIMS, DAMAGES OR EXPENSES INCURRED BY THE CUSTOMER WHICH ARISE DIRECTLY OR INDIRECTLY, IN WHOLE OR IN PART, DUE TO THE INSTALLATION OF ANY MODIFIED PART AND/OR PART RECEIVED FROM AN UNAUTHORIZED SERVICE CENTER.

NOTICE

This appliance is intended for professional use only and is to be operated by qualified personnel only. A Frymaster DEAN Factory Authorized Service Center (FASC) or other qualified professional should perform installation, maintenance, and repairs. Installation, maintenance, or repairs by unqualified personnel may void the manufacturer's warranty.

NOTICE

This equipment must be installed in accordance with the appropriate national and local codes of the country and/or region in which the appliance is installed.

NOTICE TO U.S. CUSTOMERS

This equipment is to be installed in compliance with the basic plumbing code of the Building Officials and Code Administrators International, Inc. (BOCA) and the Food Service Sanitation Manual of the U.S. Food and Drug Administration.

NOTICE

Drawings and photos used in this manual are intended to illustrate operational, cleaning and technical procedures and may not conform to onsite management operational procedures.

NOTICE TO OWNERS OF UNITS EQUIPPED WITH COMPUTERS

U.S.

This device complies with Part 15 of the FCC rules. Operation is subject to the following two conditions: 1) This device may not cause harmful interference, and 2) This device must accept any interference received, including interference that may cause undesired operation. While this device is a verified Class A device, it has been shown to meet the Class B limits.

CANADA

This digital apparatus does not exceed the Class A or B limits for radio noise emissions as set out by the ICES-003 standard of the Canadian Department of Communications.

Cet appareil numérique n'émet pas de bruits radioélectriques dépassant les limites de classe A et B prescrites dans la norme NMB-003 édictée par le Ministre des Communications du Canada.

 DANGER

Improper installation, adjustment, maintenance or service, and unauthorized alterations or modifications can cause property damage, injury, or death. Read the installation, operating, and service instructions thoroughly before installing or servicing this equipment. Only qualified service personnel may convert this appliance to use a gas other than that for which it was originally configured.

⚠ DANGER

Adequate means must be provided to limit the movement of this appliance without depending upon the gas line connection. Single fryers equipped with legs must be stabilized by installing anchor straps. All fryers equipped with casters must be stabilized by installing restraining chains. If a flexible gas line is used, an additional restraining cable must be connected at all times when the fryer is in use.

⚠ DANGER

No structural material on the fryer should be altered or removed to accommodate placement of the fryer under a hood. Questions? Call the Frymaster Dean Service Hotline at 1-800-551-8633.

⚠ DANGER

The front ledge of the fryer is not a step! Do not stand on the fryer. Serious injury can result from slips or contact with the hot oil.

⚠ DANGER

Do not store or use gasoline or other flammable liquids or vapors in the vicinity of this or any other appliance.

⚠ DANGER

Instructions to be followed in the event the operator smells gas or otherwise detects a gas leak must be posted in a prominent location. This information can be obtained from the local gas company or gas supplier.

⚠ DANGER

The crumb tray in fryers equipped with a filter system must be emptied into a fireproof container at the end of frying operations each day. Some food particles can spontaneously combust if left soaking in certain shortening material.

⚠ WARNING

Do not bang fry baskets or other utensils on the fryer's joiner strip. The strip is present to seal the joint between the fry vessels. Banging fry baskets on the strip to dislodge shortening will distort the strip, adversely affecting its fit. It is designed for a tight fit and should only be removed for cleaning.

⚠ DANGER

This product contains chemicals known to the state of California to cause cancer and/or birth defects or other reproductive harm.

Operation, installation and servicing of this product could expose you to airborne particles of glass wool or ceramic fibers, crystalline silica, and/or carbon monoxide. Inhalation of airborne particles of glass wool or ceramic fibers is known to the State of California to cause cancer. Inhalation of carbon monoxide is known to the State of California to cause birth defects or other reproductive harm.

THIS PAGE INTENTIONALLY LEFT BLANK

APPLICATION SERIES FRYERS
Table of Contents

CHAPTER 1: Service Procedures

1.1 General and Model Number Matrix.....	1-1
1.2 Wiring Diagrams.....	1-2
1.2.1 FPP35/45 Electric Ignition	1-2
1.2.2 Flatbottom Wiring.....	1-3
1.2.3 MJ35/45 Computer w/ Electronic Ignition Wiring.....	1-4
1.2.4 Dean Computer Wiring.....	1-5
1.2.5 Flatbottom Computer Wiring.....	1-6
1.2.6 Dean/Frymaster Transformer/Filter Box Wiring	1-7
1.2.7 Flatbottom 18/24 Transformer Box Wiring	1-8
1.2.8 Flatbottom 24/24 Filter Box Wiring	1-9

CHAPTER 2: Parts List

2.1 Accessories	2-1
2.2 Cabinetry.....	2-2
2.2.1 MJ35/45, H55 / D50, D60, D80 Combinations.....	2-2
2.2.2 MJ35/45, H55, D50, D60, D80 and Flatbottom Combinations.....	2-6
2.3 Top Cap Assemblies.....	2-10
2.4 Flue Caps, Control Panel Frame Assemblies and Bezels	2-12
2.5 Upper and Lower Cabinet Back Panels	2-14
2.6 Door Assemblies	2-16
2.7 Drain Assemblies	2-17
2.8 Drain Valve Assemblies	2-20
2.9 Filter Pump Assemblies	2-22
2.10 Filter Plumbing	2-24
2.11 Filter Pan Assemblies.....	2-25
2.12 Transformer and Filter Box Assemblies	2-26

APPLICATION SERIES FRYERS

CHAPTER 1: SERVICE PROCEDURES

1.1 General

Frymaster's Application Series fryers combine many types of fryers such as MJ35/45, H55, D50/60/80, Flatbottom 1824 and 2424 fryers. Service procedures for each of the specific fryers are covered in each fryers respective service and parts manuals. These manuals are accessible online at www.frymaster.com under online literature.

Fryer Service and Parts Manuals

Performance Pro-Series Gas Fryers MJ35/45	819-6092
Pro H50/55 Series Gas Fryers	819-6083
Decathlon Gas Fryers	819-5922
Flatbottom Gas Fryers	819-6031
Flatbottom Electric Fryers	819-6115
Pro Electric H14/17/22 Electric Fryers	819-5990
RE Series RE14/17/22 Electric Fryers	819-6150
1721/18UE Electric Fryers	819-5981

Application Series Model Number Matrix

Model* Configuration

Two Station Fryers

DF2x1	D-HD160/MJ-H1x5CSC
DF2x2	D-HD150/MJ-H1x5
DF2x3	D-HD160/MJ-H1x5SC
DF2x5	D-HD160/MC/MJ-H1x5
DF2x6	MJ-H1x5/D-HD150
DF2x7	D-HD160/MJ-H1x5
DF2x#	MJ-H1x5/D-HD160

Five Station Fryers

DF5x1	MJ-H2x5/D-HD360
DF5x#	22424/MC/MJ-H3x5

Six Station Fryers

DF6x1	MJ-H2x5/2424//32424
-------	---------------------

Three Station Fryers

DF3x1	D-HD160/MJ-H2x5	
DF3x2	D-HD160/MJ-H2x5	Nat Gas
DF3x3	D-HD160/MJ-H2x5	LP Gas
DF3x4	MJ-H1x5/D-HD250	
DF3x5	D-HD160/MJ-H2x5	Battered to Right of DF4x6
DF3x#	D-HD250/MJ-H1x5	
DF3x#	2424/MC/MJ-H2x5	

***NOTE: To shorten model numbers the zeros have been dropped.**

Example: DF2x1 = DF20000001

Four Station Fryers

DF4x1	MJ-H2x5/D-HD260	Alz Back
DF4x2	MJ-H2x5/D-HD250	
DF4x3	D-HD250/MJ-H2x5	
DF4x4	MJ-H2x5/D-HD260	SS Back
DF4x5	MJ-H3x5/MC/2424	
DF4x6	D-HD460	Battered to Left of DF3x5
DF4x#	D-HD160/MC/MJ-H3x5	
DF4x#	2424/MC/MJ-H3x5	
DF4x#	MJ-H2x5/21824	
DF4x#	32424/D-HD160	

APPLICATION SERIES FRYERS

CHAPTER 1: SERVICE PROCEDURES

1.2 Wiring Diagrams

1.2.1 FPP35/45 Electronic Ignition

8051556A

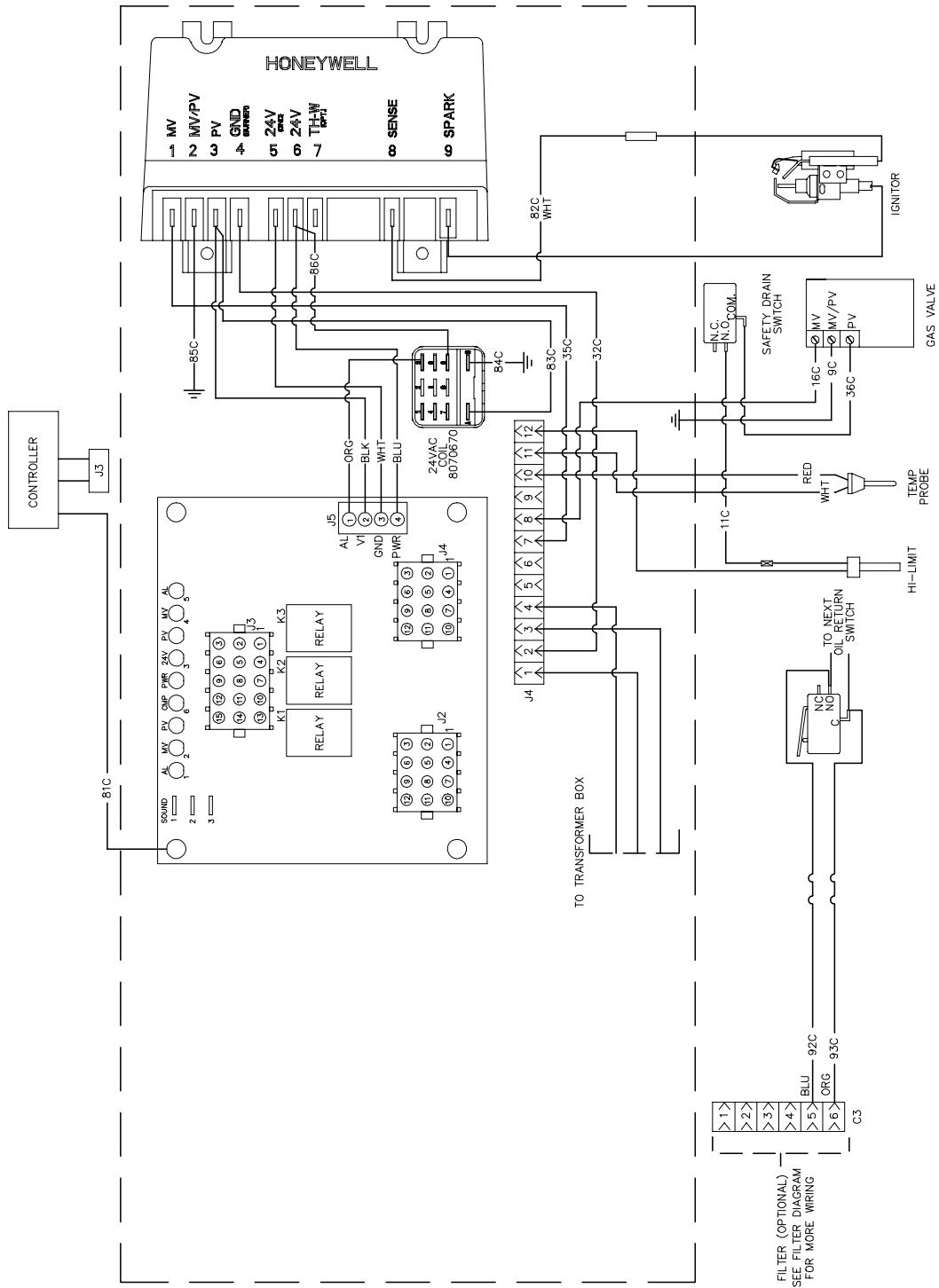

FILTER (OPTIONAL)
SEE FILTER DIAGRAM
FOR MORE WIRING

1.2.2 Flatbottom Wiring

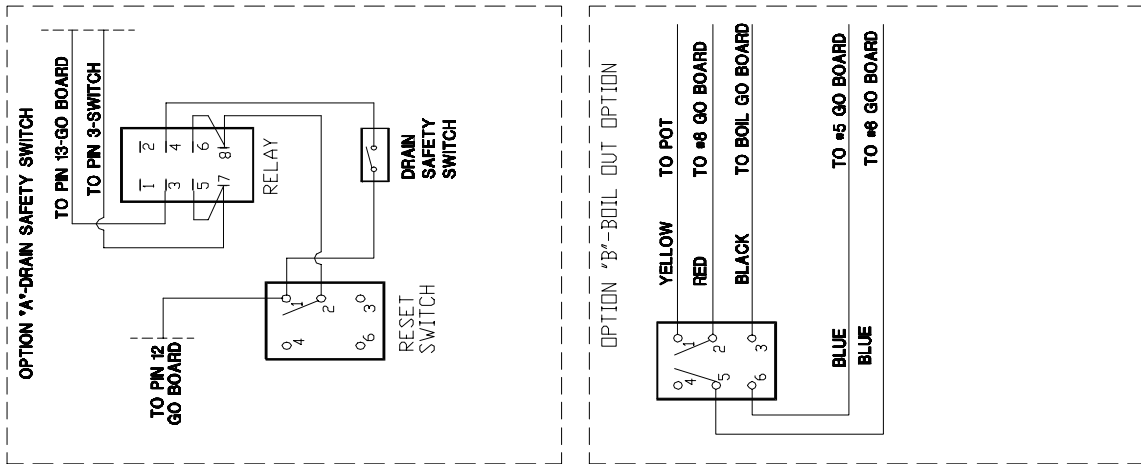
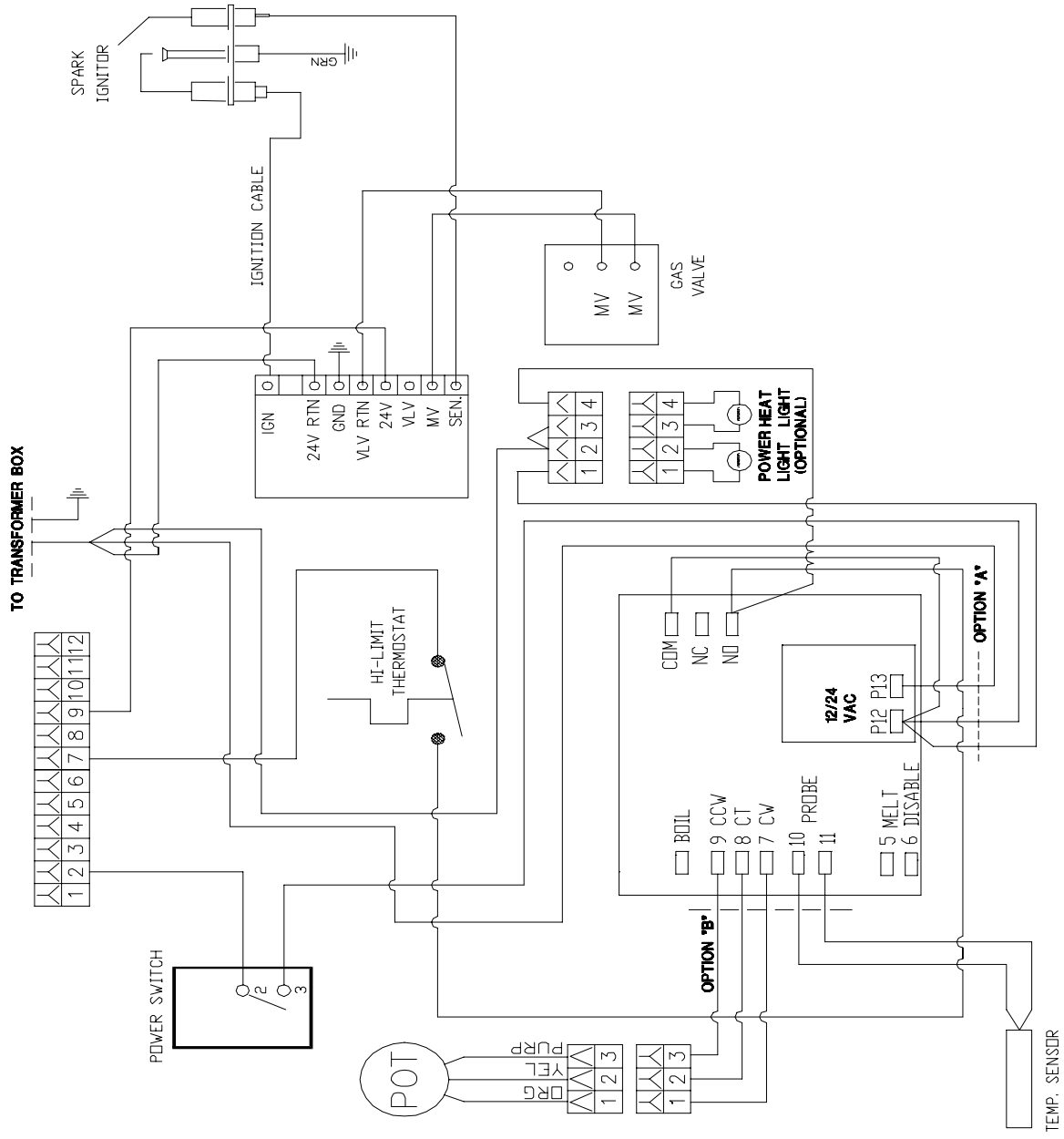

8051569A

1.2.3 MJ35/45 Computer w/ Electronic Ignition Wiring

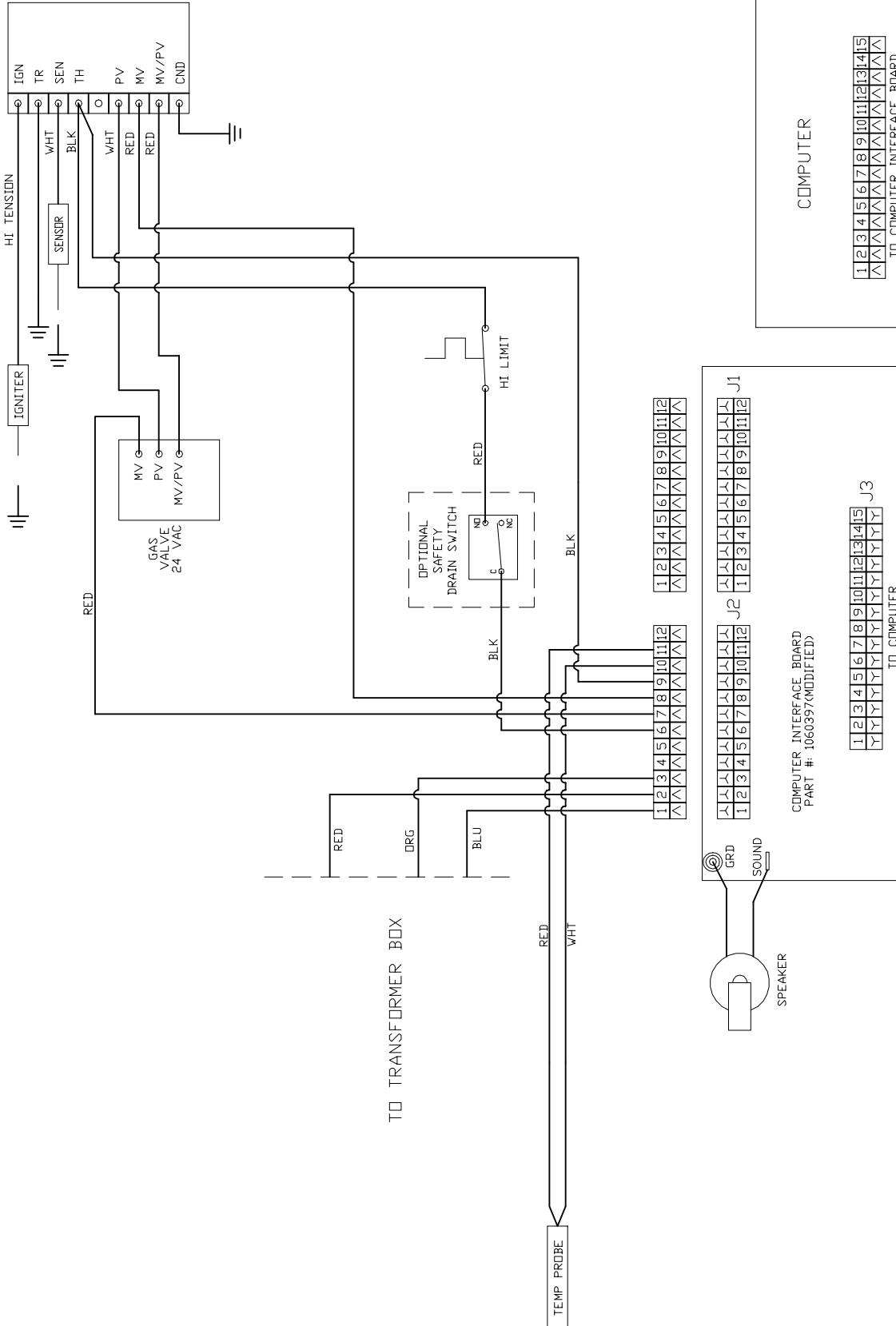

8051564A

1.2.4 Dean Computer Wiring

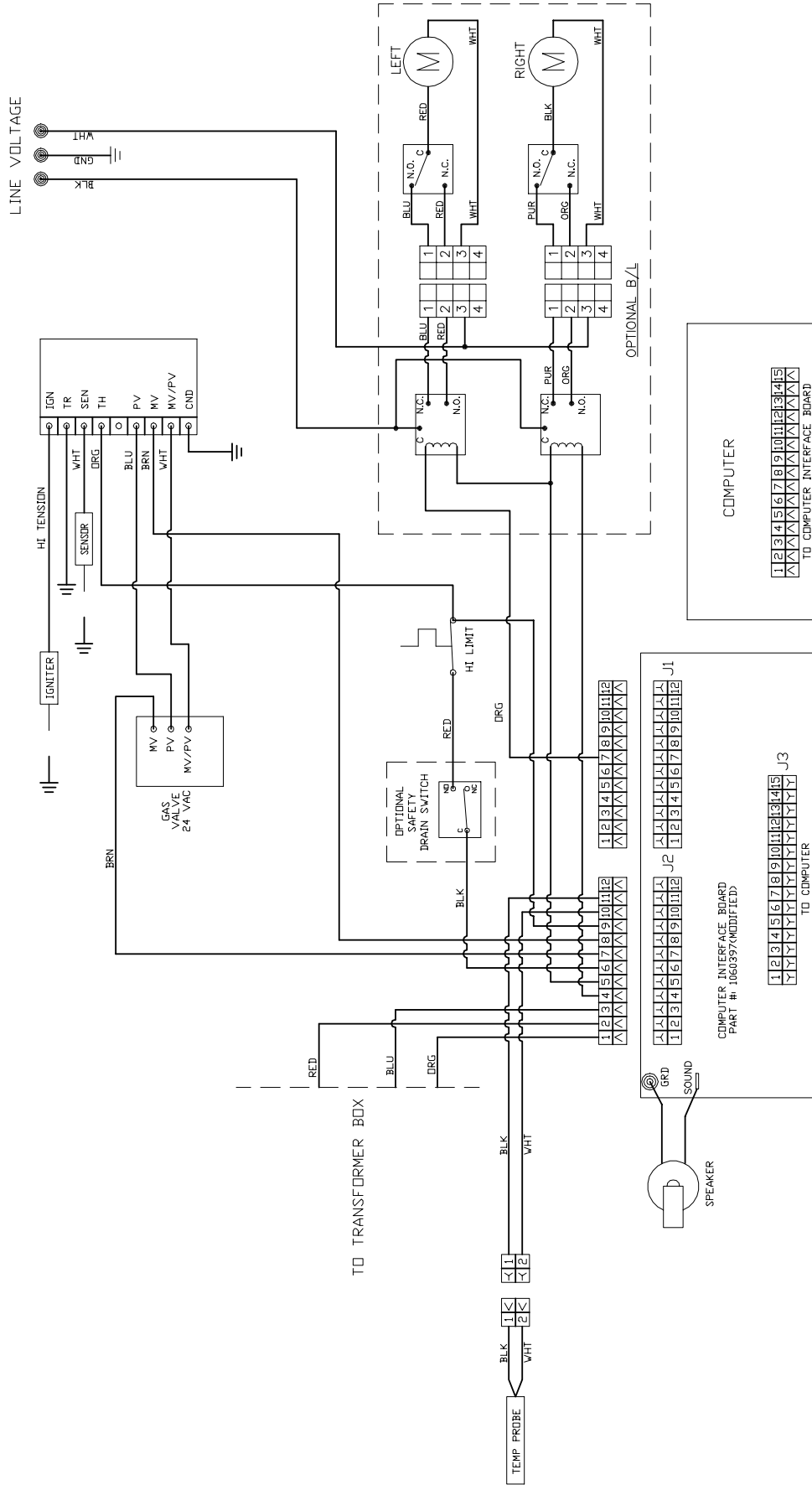

8051S45A

1.2.5 Flatbottom Computer Wiring

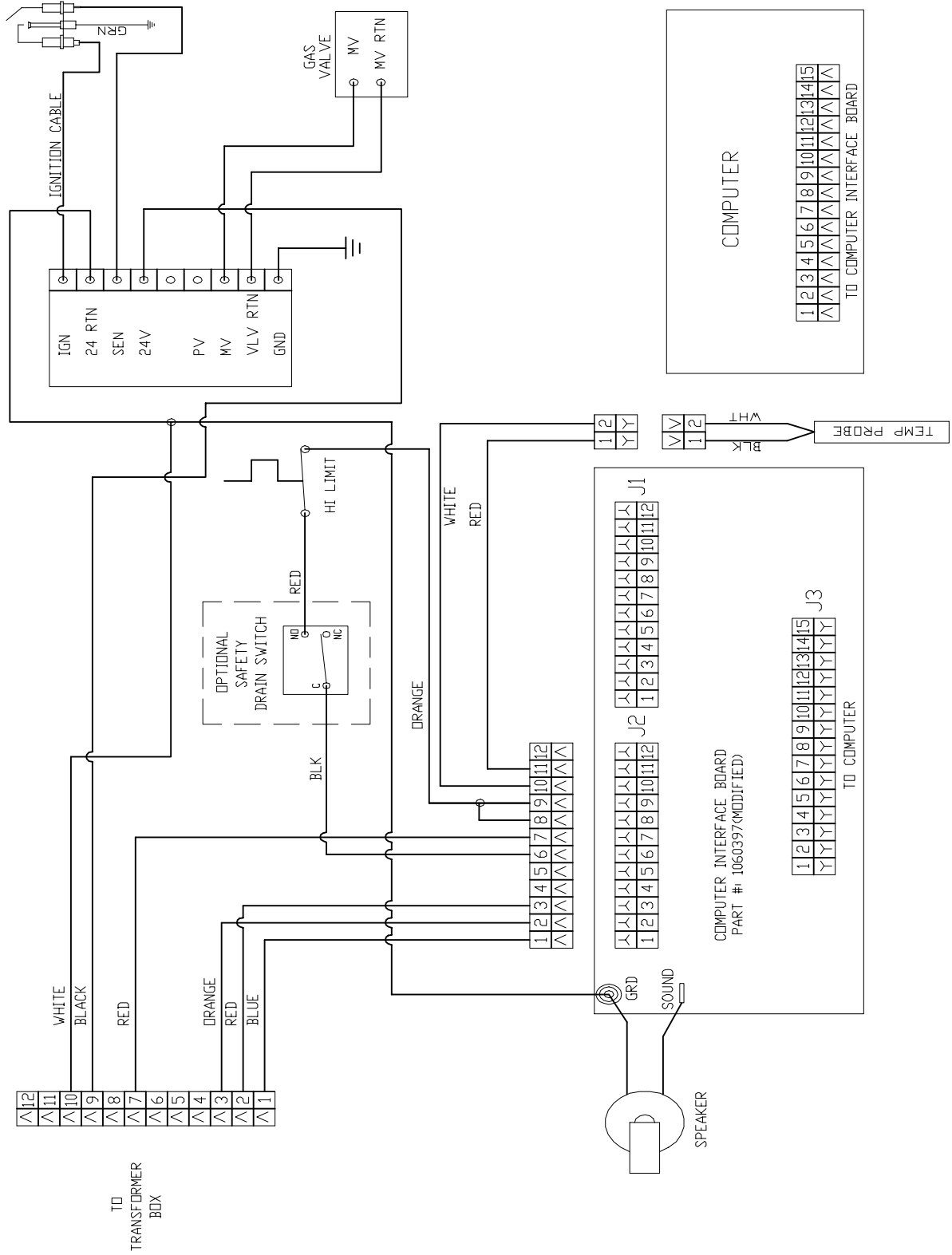

8051581A

1.2.6 Transformer/Filter Box Wiring Common Cabinet

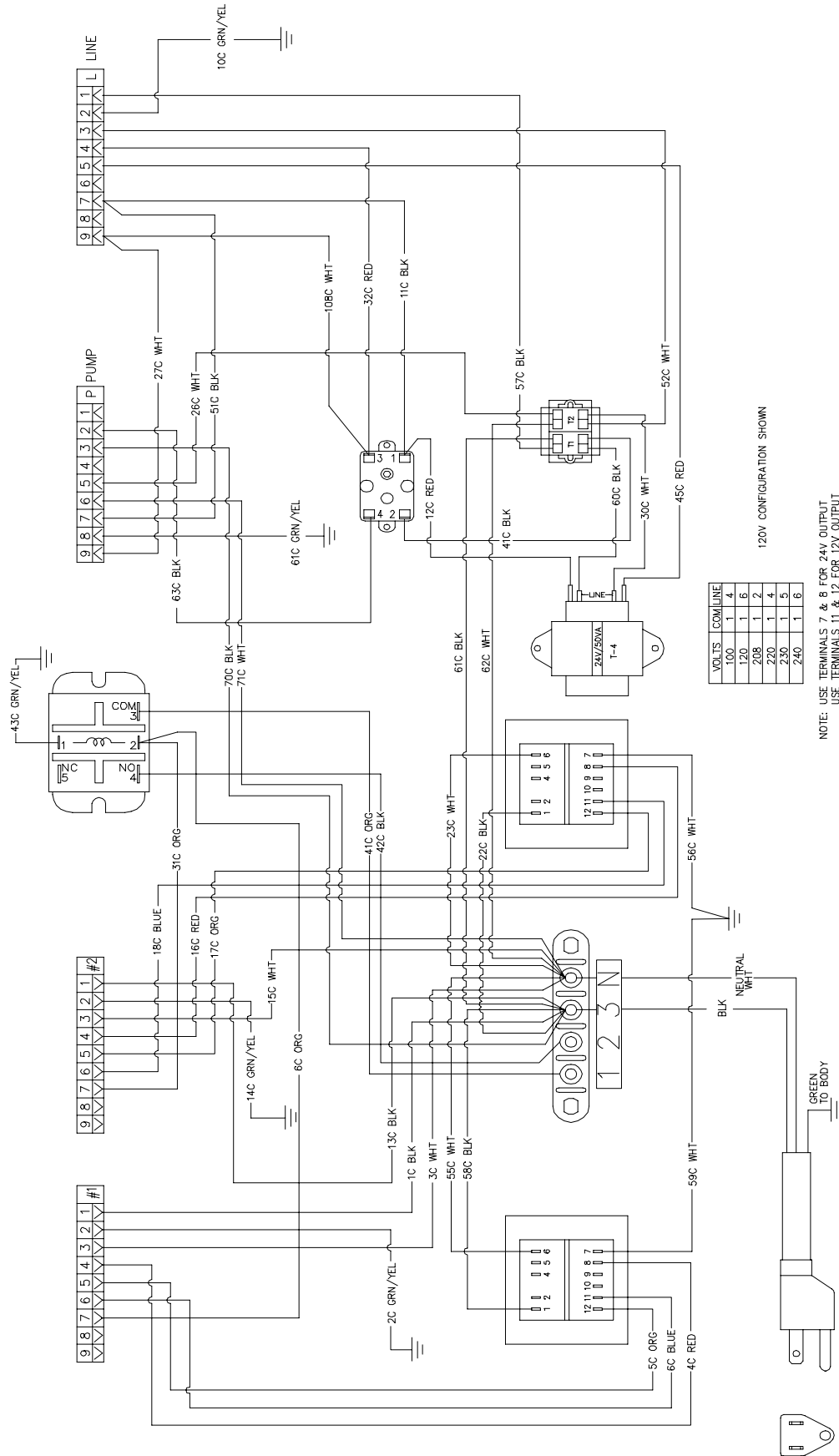

VOLTS	COM	LINE
100	1	4
120	1	6
208	1	2
220	1	4
230	1	5
240	1	6

120V CONFIGURATION SHOWN

NOTE: USE TERMINALS 7 & 8 FOR 24V OUTPUT
USE TERMINALS 11 & 12 FOR 12V OUTPUT

8051567A

1.2.7 Flatbottom 18/24 Transformer Box Wiring

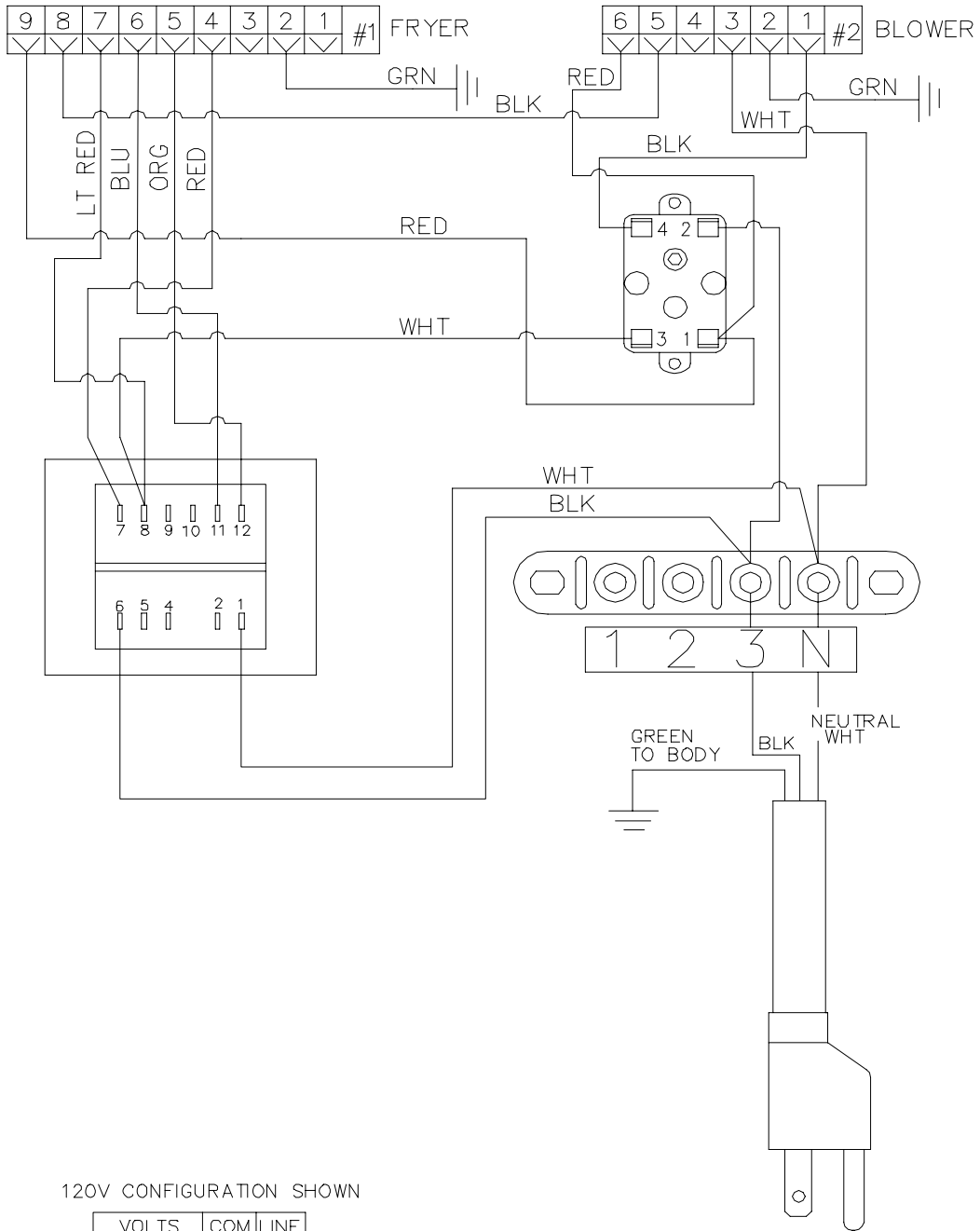

NOTE: USE TERMINALS 7 & 8 FOR 24V OUTPUT
USE TERMINALS 11 & 12 FOR 12V OUTPUT

8051568A

1.2.8 Flatbottom 24/24 Filter Box Wiring

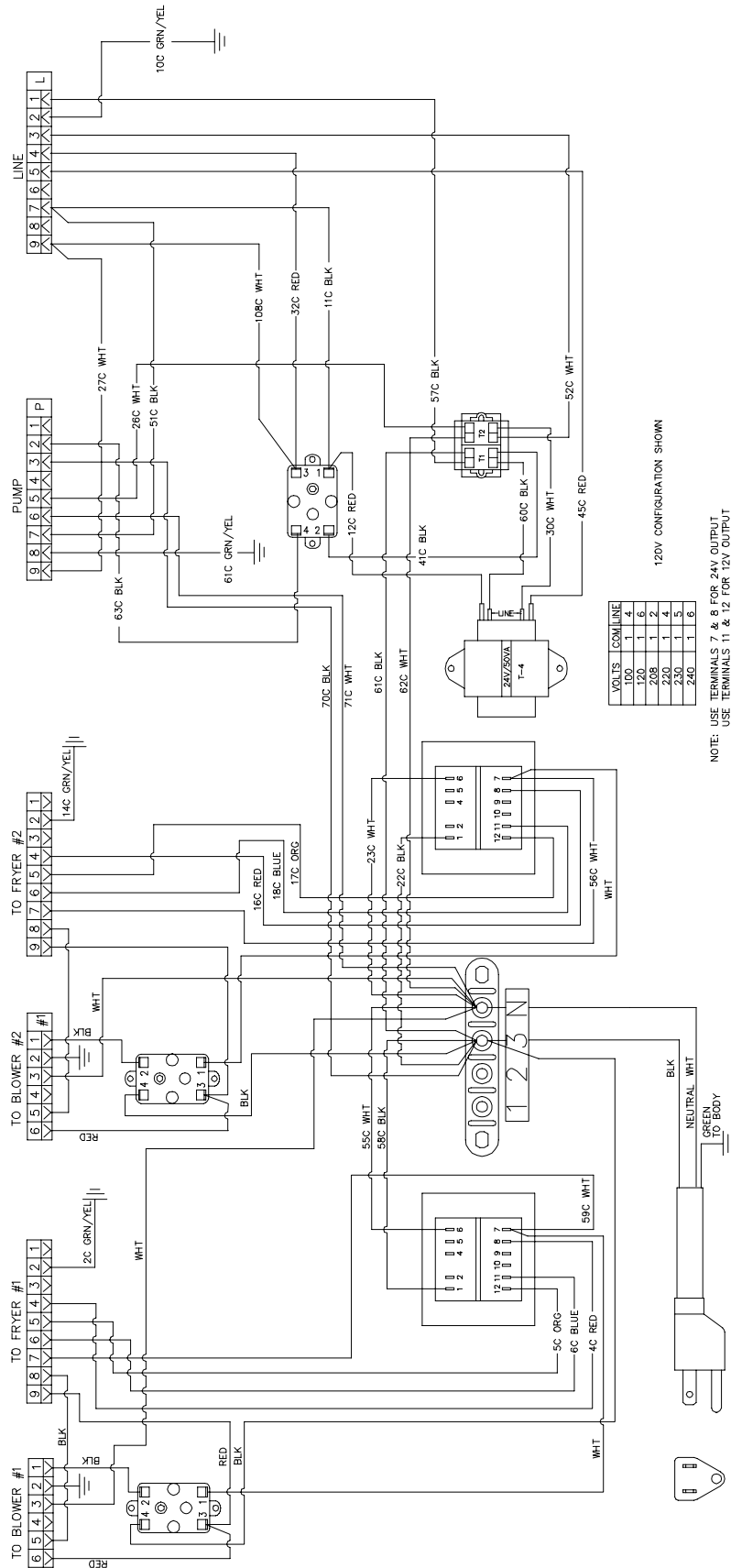

8051571A

APPLICATION SERIES FRYERS

CHAPTER 2: PARTS LIST

This manual lists the unique cabinet and filtration parts for the Application Series Fryers. For common parts pertaining to the fryer, refer to the respective fryer's service and parts manual. (ie., H50/55, Decathlon, etc.)

These manuals may be accessed online at www.frymaster.com.

Fryer Service and Parts Manuals

Performance Pro-Series Gas Fryers MJ35/45	819-6092
Pro H50/55 Series Gas Fryers	819-6083
Decathlon Gas Fryers	819-5922
Flatbottom Gas Fryers	819-6031
Flatbottom Electric Fryers	819-6115
Pro Electric H14/17/22 Electric Fryers	819-5990
RE Series RE14/17/22 Electric Fryers	819-6150
1721/18UE Electric Fryers	819-5981

2.1 Accessories and Connecting/Joiner Strips

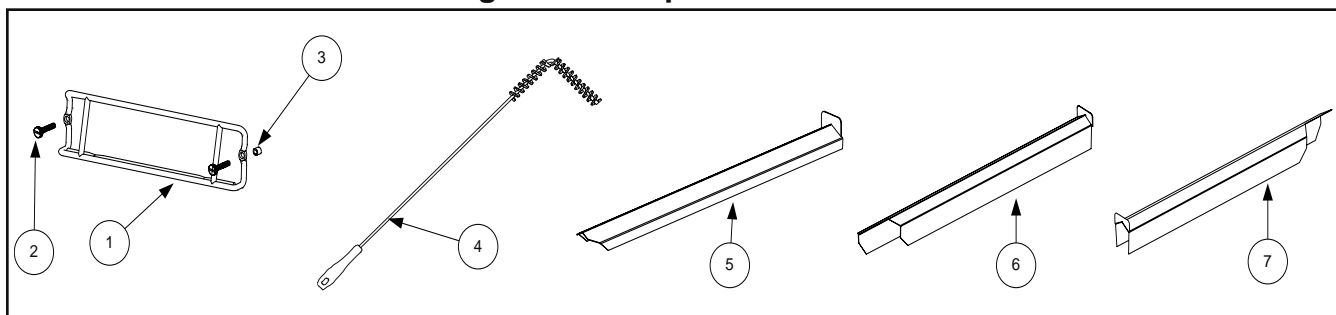

ITEM	PART #	COMPONENT
1	810-2793	Wireform Basket Hanger
*	810-2794	Wireform Basket Hanger CF
2	809-0171	Basket Hanger Screw
3	809-0921	Spacer, Basket Hanger
4	803-0278	Brush, Teflon / L-Shaped
Top Connecting and Joiner Strips		
5	823-5036	SM/D60 Connecting (joins like frypots within a system)
	823-1885	BK Type - H55, MJ Connecting (joins like frypots within a system)
*	210-4313	Flatbottom Connecting (joins like frypots within a system)
6	823-5429	D60 Left / MJ-H55 Right Joiner
	823-5366	DD250 Left / MJ-H55 Right Joiner
7	823-5037	MJ-H55 Left / D60 Right Joiner
	823-5080	MJ-H55 Left / Flatbottom (1824,2424) Right Joiner
*	826-1351	Nut Retainer, 1/4-20 Nutsert (pkg. of 10)

* Not illustrated.

2.2 Cabinetry

2.2.1 MJ35, MJ45, H55 / D50, D60, D80 Combinations

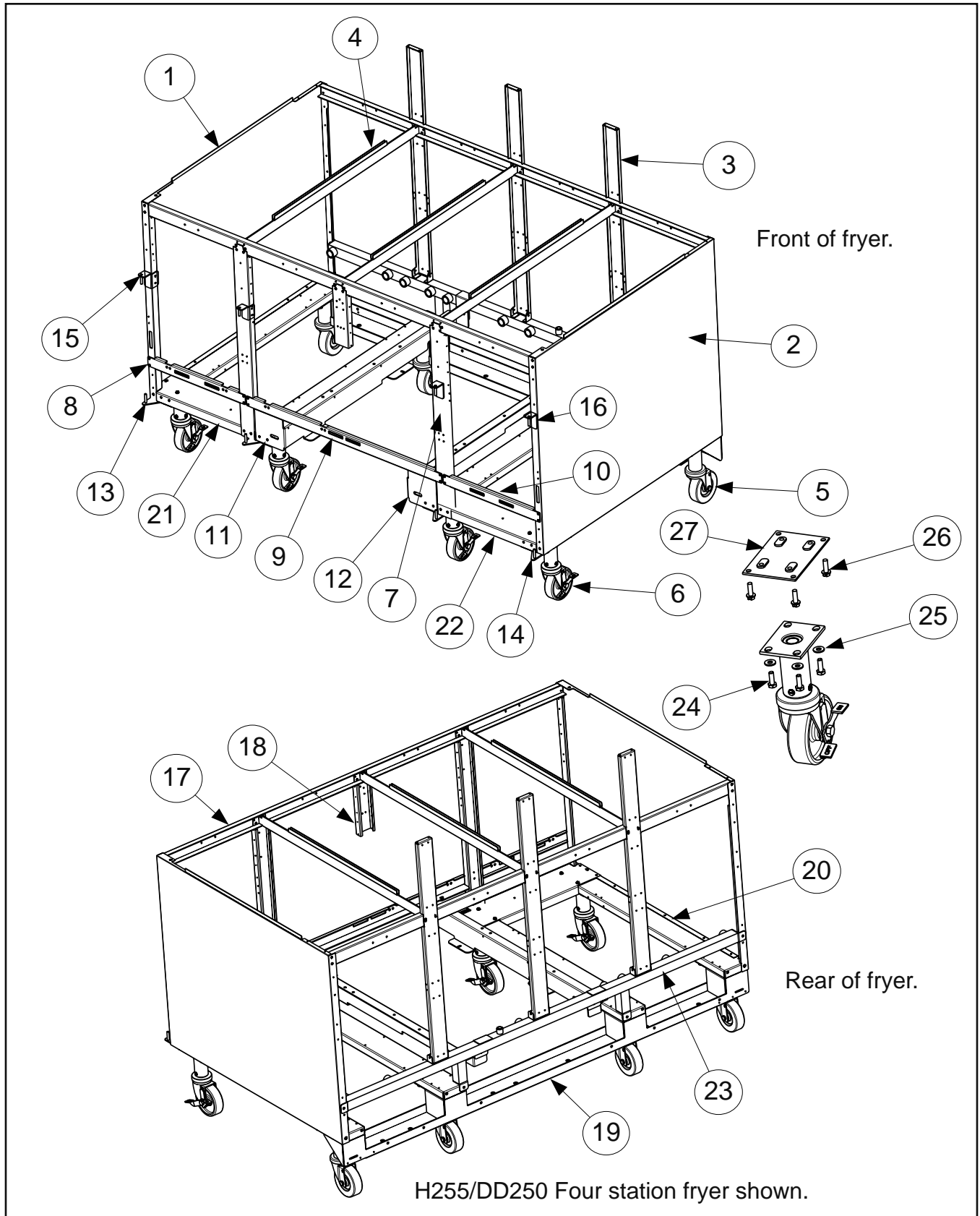

2.2.1 MJ35, MJ45, H55 / D50, D60, D80 Combinations cont.

ITEM	PART #	COMPONENT
		Cabinet Assemblies
		Two Station Fryer
	106-5324	DF2x1 (SCFD160/MJ-H1x5CSC), DF2x3 (SCFD160/MJ-H1x5SC)
	106-6837	DF2x2 (SCFD150/MJ-H1x5)
	106-6837	DF2x6 (MJ-H1x5/DD50)
	106-7518	DF2x# (MJ-H1x5/D160)
		Three Station Fryer
	106-5452	DF3x1-DF3x2-DF3x3 (D160/MJ-H2x5), DF2x5 (D160/15MC/MJ-H1x5)
	106-6834	DF3x4 (MJ-H1x5/DD250)
	106-7599	DF3x5 (D160/MJ-H2x5)
	106-7523	DF3x# (DD250/MJ-H1x5)
		Four Station Fryer
	106-4314	DF4x1 (MJ-H2x5/SCFD260), DF4x4 (MJ-H2x5/SCFD260)
	106-4432	DF4x2 (MJ-H2x5/SCFD250)
	106-5233	DF4x3 (SCFD250/MJ-H2x5)
	106-7600	DF4x6 (D460 Filter Right)
	106-7365	DF4x# (SCFD160/MC/MJ-H3x5)
		Five Station Fryer
	106-4454	DF5x1 (245E/SCFD360), DF5x# (MJ-H2x5/D360)
		Base Assemblies
		Two Station Fryer
	106-5323	DF2x1 (SCFD160/MJ-H1x5CSC), DF2x3 (SCFD160/MJ-H1x5SC)
	106-6836	DF2x2 (SCFD150/MJ-H1x5), DF2x6 (MJ-H1x5/D50)
		Three Station Fryer
	106-5451	DF3x1-DF3x2-DF3x3 (D60/MJ-H2x5), DF2x5 (D160/15MC/MJ-H1x5)
	106-6833	DF3x4 (MJ-H1x5/DD250)
	106-7522	DF3x# (DD250/ MJ-H1x5)
		Four Station Fryer
	106-4313	DF4x1 (MJ-H2x5/SCFD260), DF4x4 (MJ-H2x5/SCFD260)
	106-4434	DF4x2 (MJ-H2x5/SCFD250), DF4x3 (SCFD250/MJ-H2x5)
	106-7358	DF4x# (SCFD160/MC/MJ-H3x5)
		Five Station Fryer
	106-4455	DF5x1 (245E/SCFD360), DF5x# (MJ-H2x5/D360)
1	211-8078	Side, Left Cabinet
2	212-8078	Side, Right Cabinet
3	200-9929/8662	Post, Rear Com Cabinet (use 220-1799 for DF2x2, DF2x6, DF3x4)
4	200-8080	Divider, Frypot (use 220-1844 for DF3x4)
5	810-1494	Caster, w/o Brake Swivel 4" Wheel
6	810-0326	Caster, Adj. w/ Brake 4" Wheel
7	200-8168	Post, Front
8	200-8227	Brace, Left Lower Front H55 LT/RT
9		Brace, Center Lower Front
		Two Station Fryer
	220-0078	DF2x1 (SCFD160/MJ-H1x5CSC), DF2x3 (SCFD160/MJ-H1x5SC)
	220-0882	DF2x2 (SCFD150/MJ-H1x5), DF2x6(MJ-H1x5/DD150)
	220-0402	DF2x5 (D60/15MC/MJ-H1x5)
	220-2210	DF2x (MJ-H1x5/D160)
		Three Station Fryer
	220-0402	DF3x1-DF3x2-DF3x3 (D60/MJ-H2x5)

2.2.1 MJ35, MJ45, H55 / D50, D60, D80 Combinations cont.

ITEM	PART #	COMPONENT
10	220-0882	DF3x4 (MJ-H1x5/DD250)
		Four Station Fryer
	200-8101	DF4x1 (MJ-H2x5/SCFD260), DF4x4 (MJ-H2x5/SCFD260)
	200-8453	DF4x2 (MJ-H2x5/SCFD250), DF4x3 (SCFD250/MJ-H2x5)
	220-2129	DF4x# (SCFD160/MC/MJ-H3x5)
		Five Station Fryer
	200-9938	DF5x1 (245E/SCFD360), DF5X# (MJ-H2x5/D360)
	200-8452	Brace, Right Lower Front DD50 LT/RT
11		Three Station
	200-8227	DF3x1-DF3x2-DF3x3 (D60/MJ-H2x5), DF2x5 (D160/15MC/MJ-H1x5)
	220-0891	DF3x4 (MJ-H1x5/DD250)
		Four/Five Station
	200-8100	DF4x1 (MJ-H2x5/SCFD260), DF4x4 (MJ-H2x5/SCFD260), DF5x
	200-8452	DF4x2 (MJ-H2x5/SCFD250), DF4x3 (SCFD250/MJ-H2x5)
	200-8736	Support, Left Filter Pan MJ-H/D50 - DF4x1 (MJ-H2x5/SCFD260), DF4x4 (MJ-H2x5/SCFD260)
12	221-2194	Support, Left Filter Pan MJ-H/D60 - DF2x1 (SCFD160/MJ-H1x5CSC), DF2x3 (SCFD160/MJ-H1x5CSC), DF2x5 (D160/15MC/MJ-H1x5), DF3x1-DF3x2-DF3x3 (D60/MJ-H2x5) DF4x2 (MJ-H2x5/SCFD250), DF4x3 (SCFD250/MJ-H2x5), DF5x1 (245E/SCFD360), DF5x# (MJ-H2x5/D360)
	221-2130	DF4x# (SCFD160/MC/MJ-H3x5)
	221-1938	DF2x6 (MJ-H1x5/DD150), DF3x4 (MJ-H1x5/DD250)
	200-8737	Support, Right Filter Pan MJ-H/D50 - DF4x1 (MJ-H2x5/SCFD260), DF4x4 (MJ- H2x5/SCFD260)
	222-2194	Support, Right Filter Pan MJ-H/D60 - DF2x1 (SCFD160/MJ-H1x5CSC), DF2x3 (SCFD160/MJ-H1x5CSC), DF2x5 (D160/15MC/MJ-H1x5), DF3x1-DF3x2-DF3x3 (D60/MJ-H2x5) DF4x2 (MJ-H2x5/SCFD250), DF4x3 (SCFD250/MJ-H2x5), DF5x1 (245E/SCFD360), DF5x# (MJ-H2x5/D360)
	222-2130	DF4x# (SCFD160/MC/MJ-H3x5)
	222-1938	DF2x6 (MJ-H1x5/DD150), DF3x4 (MJ-H1x5/DD250)
*	220-1687	Bridge, Filter Pump
13	823-4894	Hinge, Lower Left Door
14	823-4895	Hinge, Lower Right Door
15	823-4729	Hinge, Upper Left Door
16	823-4730	Hinge, Upper Right Door
17		Brace, Front/Rear Upper
		Two Station Fryer
	220-0077	DF2x1 (SCFD160/MJ-H1x5CSC), DF2x3 (SCFD160/MJ-H1x5SC)
	220-1804	DF2x2 (SCFD150/MJ-H1x5), DF2x6 (MJ-H1x5/DD150 rear only)
	220-0401	DF2x5 (D160/15MC/MJ-H1x5)
	220-0878	DF2x6 (MJ-H1x5/DD150 front only)
		Three Station Fryer
	220-0401	DF3x1-DF3x2-DF3x3 (D60/MJ-H2x5)
	220-1804	DF3x4 (MJ-H1x5/DD250 rear only)
	220-0886	DF3x4 (MJ-H1x5/DD250 front only)
		Four Station Fryer
	200-8082	DF4x1 (MJ-H2x5/SCFD260), DF4x4 (MJ-H2x5/SCFD260)
	200-8455	DF4x2 (MJ-H2x5/SCFD250), DF4x3 (SCFD250/MJ-H2x5)
220-2128	DF4x# (SCFD160/MC/MJ-H3x5)	

* Not illustrated.

2.2.1 MJ35, MJ45, H55 / D50, D60, D80 Combinations cont.

ITEM	PART #	COMPONENT
	200-8504	Five Station DF5x1 (245E/SCFD360), DF5x# (MJ-H2x5/D360)
18	200-2235	Bracket, Component Box Support
19		Channel, Base Rear
		Two Station Fryer
	220-2190	DF2x1 (SCFD160/MJ-H1x5CSC), DF2x3 (SCFD160/MJ-H1x5SC)
	220-1335	DF2x2 (SCFD150/MJ-H1x5), DF2x6 (MJ-H1x5/DD150 front only)
	220-2195	DF2x5 (D160/15MC/MJ-H1x5)
		Three Station Fryer
	220-2195	DF3x1-DF3x2-DF3x3 (D60/MJ-H2x5)
	220-1939	DF3x4 (MJ-H1x5/DD250)
	220-2219	DF3x# (DD250/MJ-H1x5)
		Four Station Fryer
	220-2198	DF4x1 (MJ-H2x5/SCFD260), DF4x4 (MJ-H2x5/SCFD260)
	220-2199	DF4x2 (MJ-H2x5/SCFD250), DF4x3 (SCFD250/MJ-H2x5)
	220-2126	DF4x# (SCFD160/MC/MJ-H3x5)
		Five Station Fryer
	220-2203	DF5x1 (245E/SCFD360), DF5X# (MJ-H2x5/D360)
20	823-4851/5790	Channel, Base Side DF2x6 (MJ-H1x5/DD150 front only), DF3x4 (MJ-H1x5/DD250)
21	200-8098	Channel, Base Front Left, Five Station, DF5x1 (245E/SCFD360), DF5x# (MJ-H2x5/D360)
22		Channel, Base Front Right
		Two Station Fryer
	200-8450	DF2x5 (D160/15MC/MJ-H1x5)
		Three Station Fryer
	200-8450	DF3x1-DF3x2-DF3x3 (D60/MJ-H2x5)
	220-0890	DF3x4 (MJ-H1x5/DD250)
		Four Station Fryer
	200-8095	DF4x1-DF4x4 (MJ-H2x5/SCFD260)
	200-8450	DF4x2 (MJ-H2x5/SCFD250), DF4x3 (SCFD250/MJ-H2x5)
	220-2127	DF4x# (SCFD160/MC/MJ-H3x5)
		Five Station Fryer
	200-8505	DF5x1 (245E/SCFD360), DF5x# (MJ-H2x5/D360)
23		Manifold, Assembly -Oil Return / Rear Support
		Two Station Fryer
	810-3155	DF2x1 (SCFD160/MJ-H1x5CSC), DF2x3 (SCFD160/MJ-H1x5SC)
	810-3113	DF2x5 (D160/15MC/MJ-H1x5)
	810-3117	DF2x6 (MJ-H1x5/DD150)
		Three Station Fryer
	810-3156	DF3x1-DF3x2-DF3x3-DF3x# (D60/MJ-H2x5)
	810-3117	DF3x4 (MJ-H1x5/DD250)
		Four Station Fryer
	810-3157	DF4x1-DF4x4 (MJ-H2x5/SCFD260)
	810-3158	DF4x2 (MJ-H2x5/SCFD250), DF4x3 (SCFD250/MJ-H2x5)
	823-6015	DF4x# (SCFD160/MC/MJ-H3x5)
		Five Station Fryer
	823-4973	DF5x1 (245E/SCFD360), DF5x# (MJ-H2x5/D360)
24	826-1389	Screw, Hex Head 1/4-20 x 3/4 (Qty. of 10)
25	801-0189	Washer, 1/4 Flat
26	809-0821	Screw, Hex Head 1/4-20 x 3/4
27	823-4891	Plate, Front Caster Mounting

2.2.2 MJ35, MJ45, H55, D50, D60, D80 and Gas Flatbottom Combinations

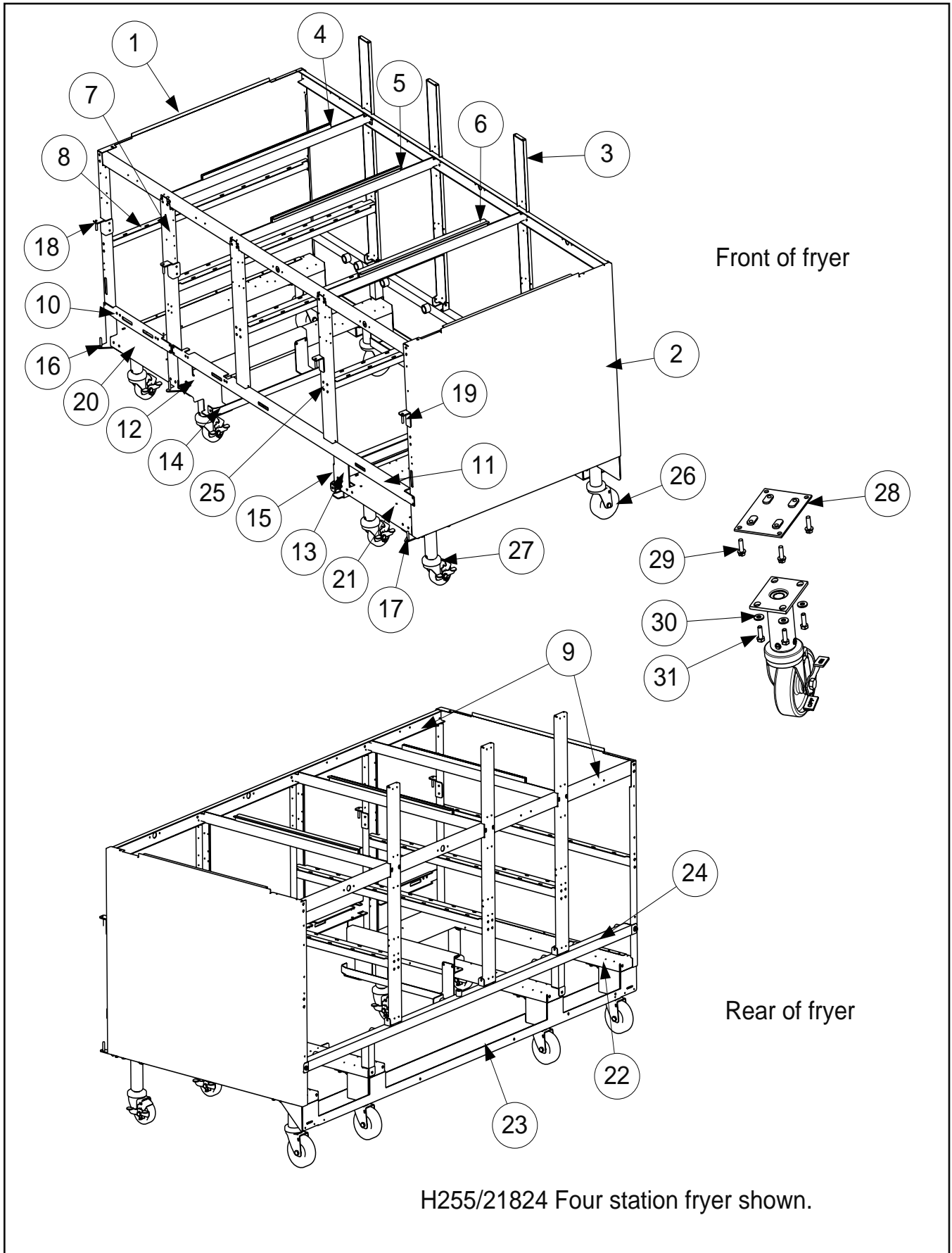

2.2.2 MJ35, MJ45, H55, D50, D60, D80 and Gas Flatbottom Combinations cont.

ITEM	PART #	COMPONENT
		Cabinet Assemblies
		Two/Four Station Fryer
	106-5348	DF2x# (1824/2424 Left non-filter)
	106-5153	DF2x# (22424 Left), DF4x# (Left 32424/D60)
	106-5487	DF2x# (22424 Right)
	106-5382	DF2x# (22424 Right non-filter)
	106-5349	DF2x# (SCF22424 Right)
	106-5154	DF2x# (2424/D60 Right), DF4x# (Right 32424/D60)
	106-5136	DF2x# (2424/2424)
		Three/Five/Six Station Fryer
	106-4751	DF3x# (MJ-H2x5/FB), DF6x1 (Left MJ-H2x5/2424//32424)
	106-5458	DF3x# (32424E), DF6x1 (Right MJ-H2x5/2424//32424)
	106-4712	DF3x# (32424 Right)
	106-5420	DF3x# (MJ-Hx5/D60/1824)
	106-7028	DF5x# (Left 22424/26MC//MJ-H3x5)
	106-7008	DF5x# (Right 22424/26MC//MJ-H3x5)
		Four Station Fryer
	106-5468/5349	DF4x5 (MJ-H3x5//MC24/2424) Four Station w/ spreader cabinet
	106-5376	DF4x# (MJ-H2x5/21824)
		Base Assemblies
		Two/Four Station Fryer
	106-5350	DF2x# (1824/2424L non-filter)
	106-5381	DF2x# (22424 R non-filter)
	106-4983	DF2x# (22424L, 22424R, 2424), DF4x# (Left 22424//2424/D60)
	106-4986	DF2x# (2424 or 1824 and D60), DF4x# (Right 22424//2424/D60)
		Three/Five/Six Station Fryer
	106-4752	DF3x# (MJ-H2x5/FB), DF6x1(Left MJ-H 2x5/2424//32424)
	106-5445	DF3x# (32424E)
	106-5421	DF3x# (MJ-Hx5/D60/1824)
	106-7029	DF5x#(Left 22424/26MC//MJ-H3x5)
	106-4711	DF6x1 (Right MJ-H2x5/2424//32424)
		Four Station Fryer
	106-5472/4983	DF4x5 (MJ-H3x5//MC24/2424) Four Station w/ spreader cabinet
	106-5377	DF4x# (MJ-H2x5 / 21824)
1		Side, Left Cabinet
	211-8078	2424L, H2xx/21824, H255/FB, H55/D60/1824, MJ/H3x5L, 1824/2424L
	221-0012	2424L, MJ-H3x5L, 2424L non-filter (has openings for connecting fryers)
	201-8942	2424/D60 (has openings for connecting fryers)
	231-0395	32424E - YUM
2		Side, Right Cabinet
	202-8942	2424R, (has openings for connecting fryers)
	212-8078	MJ-H2x5/21824, MJ-H2x5/FB, MJ-Hx5/D60/1824, SCF2424R, 2424R, 2424/D60
	222-0012	MJ/H3x5R, 1824/2424R (has openings for connecting fryers)
	232-0395	32424E - YUM
3		Post, Rear
	200-8882	MJ-H2x5/21824, MJ-H2x5/FB, MJ-Hx5/D60/1824, 2424R, 2424/D60, 2424L

continued on next page...

2.2.2 MJ35, MJ45, H55, D50, D60, D80 and Gas Flatbottom Combinations cont.

ITEM	PART #	COMPONENT
	200-8662	MJ/H3xxL
	220-0404	32424E - YUM
	200-9232	SCF2424R, 1824/2424L, 2424, 2424R non-filter
		Divider, Frypot
4	200-8080	MJxxx, Hxxx Pot Divider
5	200-8873	MJxxx, H2xx / 1824, 2424 Divider
6	200-8912	1824, 2424 Flatbottom Pot Divider
7	200-8168	Post, Front Cabinet
8	200-8903	Brace, Firebox FB
9		Brace, Upper Front/Rear
		Two Station Fryer
	200-9229	DF2x# (2424L, SCF2424, 2424, 2424R, 2424R non-filter)
	200-9239	DF2x# (2424/D60, 1824/2424L non-filter)
		Three Station Fryer
	200-8874	DF3x# (MJ-H2x5/FB)
	220-0370	DF3x# (32424E)
	220-0291	DF3x# (MJ-Hx5/D60/1824)
		Four Station Fryer
	220-0210	DF4x# (MJ-H2xx/21824)
10	200-8227	Brace, Left Lower Front MJ-Hx5 LT/RT
11		Brace, Right/Center Lower Front
		Two Station Fryer
	200-9240	DF2x# (1824/2424L non-filter, 2424/D60)
	200-9231	DF2x# (2424, 2424/2424L, SCF2424R, 2424R, 2424R non-filter)
		Three Station Fryer
	200-8878	DF3x# (MJ-H2x5/FB)
	220-0371	DF3x# (32424E)
	220-0290	DF3x# (MJ-Hx5/D60/1824)
		Four Station Fryer
	220-0214	DF4# (MJ-H2x5/21824)
*		Bridge, Filter Pump
*	200-8932	MJ-H2x5/FB
*	220-0380	32424E - YUM
12	201-9764	Rail, Filter Pan Left
*	221-0289	Rail, Filter Pan Left MJ-Hx5/D60/1824
13	202-9764	Rail, Filter Pan Right
*	222-0289	Rail, Filter Pan Right MJ-Hx5/D60/1824
14	201-9890	Guide, Filter Pan Left
15	202-9890	Guide, Filter Pan Right
16	823-4894	Hinge, Lower Left Door (all models)
17	823-4895	Hinge, Lower Right Door (all models)
18	823-4729	Hinge, Upper Left Door MJ-Hx5
	823-5520	Hinge, Upper Left Door 24 (32424E)
	823-5136	Hinge, Upper Left Door FB (1824/2424L)
19	823-4730	Hinge, Upper Right Door MJ-Hx5
	823-5521	Hinge, Upper Right Door 24 (32424E)
	823-5137	Hinge, Upper Right Door (SCF2424R, 2424R)

* Not illustrated.

continued on next page...

2.2.2 MJ35, MJ45, H55, D50, D60, D80 and Gas Flatbottom Combinations cont.

ITEM	PART #	COMPONENT
20		Channel, Cabinet Base Front Left/Center
		Two Station Fryer
	200-9228	DF2x# (2424/2424L, 2424, SCF2424R, 2424R)
	200-9241	DF2x# (1824/2424L non-filter, 2424/D60)
	220-0036	DF2x# (2424R non-filter)
		Three/Five Station Fryer
	200-8098	DF3x# (MJ-H2x5/FB, MJ-Hx5/D60/1824)
	200-9228	DF3x# (32424E)
	220-2033	DF5x# (22424/26MC/MJ-H3x5)
		Four Station Fryer
	200-8098	DF4x# (MJ-H2xx/21824)
22	220-0207	Channel, Cabinet Base Front Right D60
		Three Station Fryer
	220-0331	DF3x# (32424E)
		Four Station Fryer
	220-0207	DF4x# (MJ-H2xx/21824)
23		Channel, Cabinet Base Rear
		Two Station Fryer
	823-5155	DF2x# (2424/2424L, 2424, SCF2424R, 2424R, 2424R non-filter)
	823-5162	DF2x# (1824/2424L non-filter, 2424/D60 Right)
		Three/Five Station Fryer
	823-5102	DF3x# (MJ-H2x5/FB)
	823-5518	DF3x# (32424E)
	823-5498	DF3x# (MJ-Hx5/D60/1824)
	220-2031	DF6x# (22424/26MC//MJ-H3x5)
		Four Station Fryer
	823-5466	DF4x# (MJ-H2x5/21824)
24		Manifold, Rear Support
		Two Station Fryer
	823-5158	DF2x# (22424L/R 2424R non-filter), DF4x#(Left 32424/D60)
	823-5435	DF2x# (1824/2424L non-filter)
	823-5161	DF2x# (2424/D60 Right), DF4x# (32424/D60 Right)
		Four Station Fryer
	823-5540	DF4x5 (MJ-H3x5/24MC/2424)
	823-5468	DF4x# (MJ-H2x5/21824)
		Five Station Fryer
	823-5094	DF5x1 (MJ-H2x5/D360)
		Six Station Fryer
	823-5103	DF6x1 (MJ-H2x5/24/32424 Left)
	823-5094	DF6x1 (MJ-H2x5/24/32424 Right)
25	200-8871	Bracket, Component Box Support
26	810-1494	Caster, w/out Brake 4" wheel
27	810-0944	Caster, w/ Brake 4" wheel
28	823-4891	Plate, Front Caster Mounting
29	809-0821	Screw, Hex Head 1/4-20 x 3/4
30	801-0189	Washer, 1/4 Flat
31	826-1389	Screw, Hex Head 1/4-20 x 3/4 (Qty. of 10)

2.3 Top Cap Assemblies

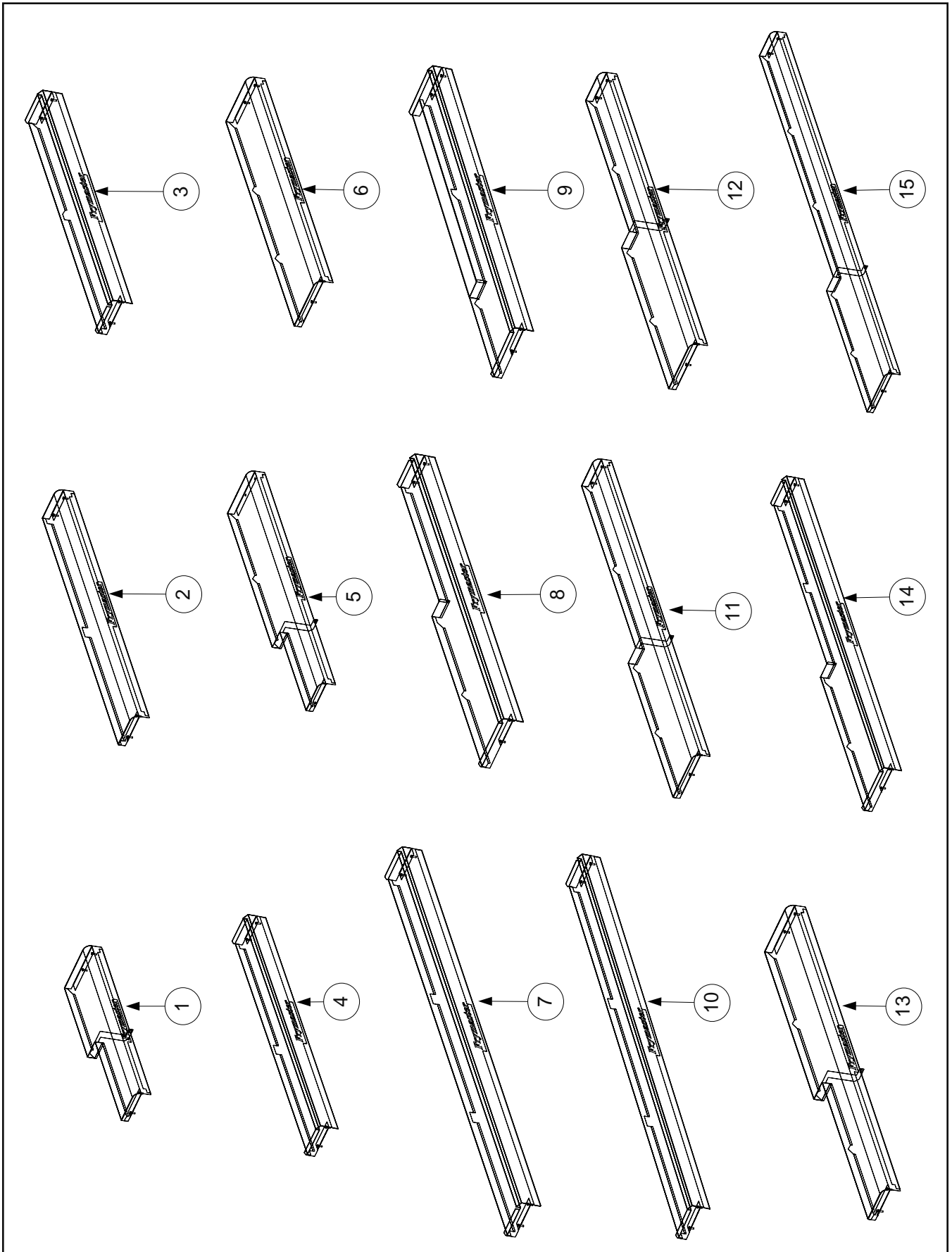

continued on next page...

2.3 Top Cap Assemblies cont.

ITEM	PART #	COMPONENT
		Topcap Assemblies / Marine Edges
		Two Station Topcaps
1	106-5318	DF2x1 (SCFD160/MJ-H1x5CSC), DF2x3 (SCFD160/MJ-H1x5SC)
5	106-5496	DF2x5 (D160/15MC/MJ-H1x5)
*	106-6798	DF2x6 (MJ-H1x5/DD150)
2	106-5471	DF4x5 (MC24/2424) Right Side
3	823-5301	DF4x# (2424/D60) Right Side
4	823-5308	DF4x# (22424) Right Side notched on left
*	823-5478	DF4x# (22424) Left Side notched on right
		Three Station Topcaps
5	106-5496	DF3x1-DF3x2-DF3x3-DF3x5 (D60/MJ-H2x5)
6	106-5470	DF4x5 (MJ-H3x5) Left Side
7	823-5123	DF6x1 (32424) Right Side
8	823-5078	DF6x1 (MJ-H2x5/2424) Left Side
9	823-5504	DF3x# (MJ-Hx5/D60/1824)
10	823-5514	32424E - YUM
*	823-5989	DF5x# (22424/MC/MJ-H3x5 Notched Right) Left Side
*	823-5982	DF5x# (22424/MC/MJ-H3x5 Notched Left) Right Side
		Four Station Topcaps
11	106-4653	DF4x1 (MJ-H2x5/SCFD260), DF4x4 (MJ-H2x5SC/SCFD260)
12	106-4654	DF4x2 (MJ-H2x5/SCFD250)
13	106-5234	DF4x3 (SCFD250/MJ-H2x5)
*	106-7638	DF4x6 (D460 Filter Right)
14	823-5467	DF4x# (MJ-H2x5/21824)
*	106-7368	DF4x# (SCFD160/MC/MJ-H3x5)
		Five Station Topcaps
15	106-4655	DF5x1 (MJ-H2x5/D360)

* Not illustrated.

2.4 Flue Caps, Control Panel Frame Assemblies and Bezels

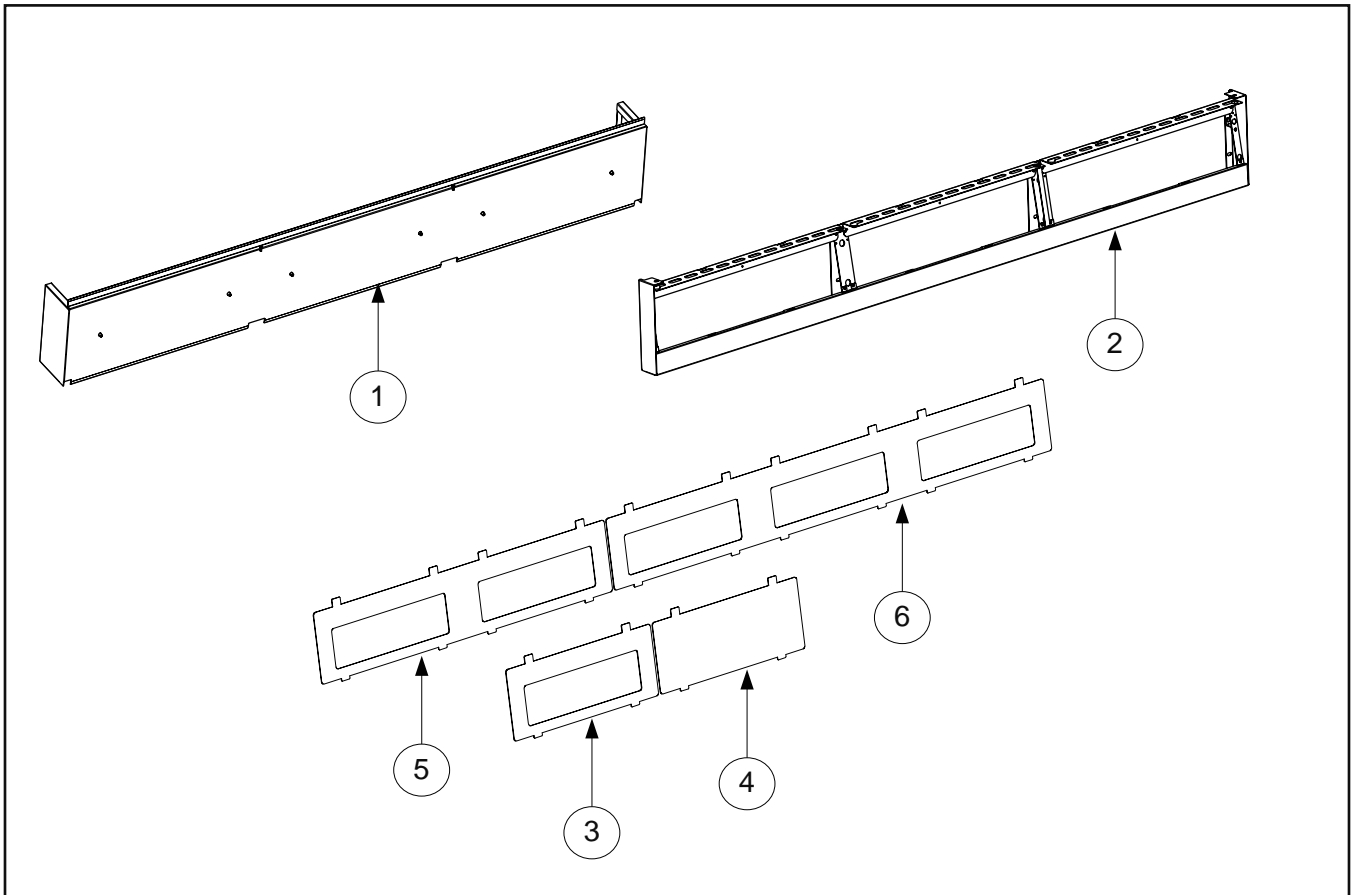

ITEM	PART #	COMPONENT
1		Fluecap Assemblies
		Two Station Fluecaps
	106-5319	DF2x1 (SCFD160/MJ-H1x5CSC), DF2x3 (SCFD160/MJ-H1x5SC)
	106-5137	DF4x5 (24MC/2424) Right Side
		Three Station Fluecaps
	106-5455	DF3x1-DF3x2-DF3x3 (D60/MJ-H2x5), DF2x5 (D160/15MC/MJ-H1x5)
	106-6827	DF3x4 (MJ-H1x5/DD250)
	106-5432	DF3x# (MJ-Hx5/D60/1824)
	106-5469	DF4x5 (MJ-H3x5) Left Side
	106-4926	DF6x1 (MJ-H2x5/2424) Left Side
	106-4927	DF6x1 (32424) Right Side
	823-5514	32424E - YUM
	106-7069	DF5x# (22424/MC/MJ-H2x5)
		Four Station Fluecaps
	106-4389	DF4x1 (MJ-H2x5/SCFD260), DF4x4 (MJ-H2x5SC/SCFD260)
	106-4656	DF4x2 (MJ-H2x5/SCFD250)
	106-5235	DF4x3 (SCFD250/MJ-H2x5)
	106-5378	DF4x# (MJ-H2x5/21824)
	106-7366	DF4x# (SCFD160/MC/MJ-H3x5)
		Five Station Fluecaps
	106-4657	DF5x1 (MJ-H3x5/SCFD360), DF5x# (MJ-H2x5/D360)

2.4 Flue Caps, Control Panel Frame Assemblies and Bezels

ITEM	PART #	COMPONENT
2		Control Panel Frame Assemblies
		Two Station Assembly
	106-5320	DF2x1 (SCFD160/MJ-H1x5CSC), DF2x3 (SCFD160/MJ-H1x5SC)
	106-6826	DF2x6 (MJ-H1x5/DD150)
	106-5495	DF2x5 (D160/15MC/MJ-H1x5)
	106-4984	DF4x# (24MC/2424), DF4x# (32424/D60)
		Three Station Assembly
	106-5453	DF3x1-DF3x2-DF3-3 (D60/MJ-H2x5)
	106-5431	DF3x# (MJ-Hx5/D60/1824)
	106-6332	DF3x4 (MJ-H1x5/DD250)
	106-5467	DF4x5 (MJ-H3x5) Left Side
	106-4754	DF6x1 (MJ-H2x5/2424) Left Side
	106-4918	DF6x1 (32424) Right Side
	106-5446	32424E - YUM
		Four Station Assembly
	106-4315	DF4x1 (MJ-H2x5/SCFD260), DF4x4 (MJ-H2x5SC/SCFD260), DF4x# (MJ-H2x5/21824)
	106-5375	DF4x2 (MJ-H2x5/SCFD250)
	106-4433	DF4x3 (SCFD250/MJ-H2x5)
	106-7367	DF4x# (SCFD160/MC/MJ-H3x5)
		Five Station Assembly
	106-4456	DF5x1 (MJ-H2x5/SCFD360), DF5x# (MJ-H2x5/D360)
		Bezels
3		Single
	210-5046	MJ-Hx5 - DF4x5
	210-9266	D60 - DF4x#
	210-8971	Flatbottom - DF4x5, DF4x#, DF6x#
	210-7002	MJ-Hx5 Blank
4	230-0439	2424 Blank - DF4x5
	230-0394	2424E - 32424E - YUM
	230-0394	2424 -with Thermatron
5		Two Station
	230-0090	D160/MJ-H1x5 - DF2x1, DF2x2, DF2x3,
	210-5819	MJ/Hxx5 - DF4x1, DF4x2, DF4x3, DF4x4, DF4x5, DF4x#, DF5x1, DF5x#, DF6x1
	210-8522	D250 - DF4x2, DF4x3
	210-8175	D260 - DF4x1, DF4x4
	230-1675	DF2x5 (D160/15MC/MJ-H1x5)
6		Three Station
	230-0410	D60/MJ/H2x5 - DF3x1, DF3x2. DF3x3
	230-1948	D350 - DF3x4 (MJ-H1x5/DD250)
	230-0338	MJ-Hx5/D60/1824 - DF3x#
	210-8509	D360 - DF5x1

2.5 Upper and Lower Cabinet Back Panels

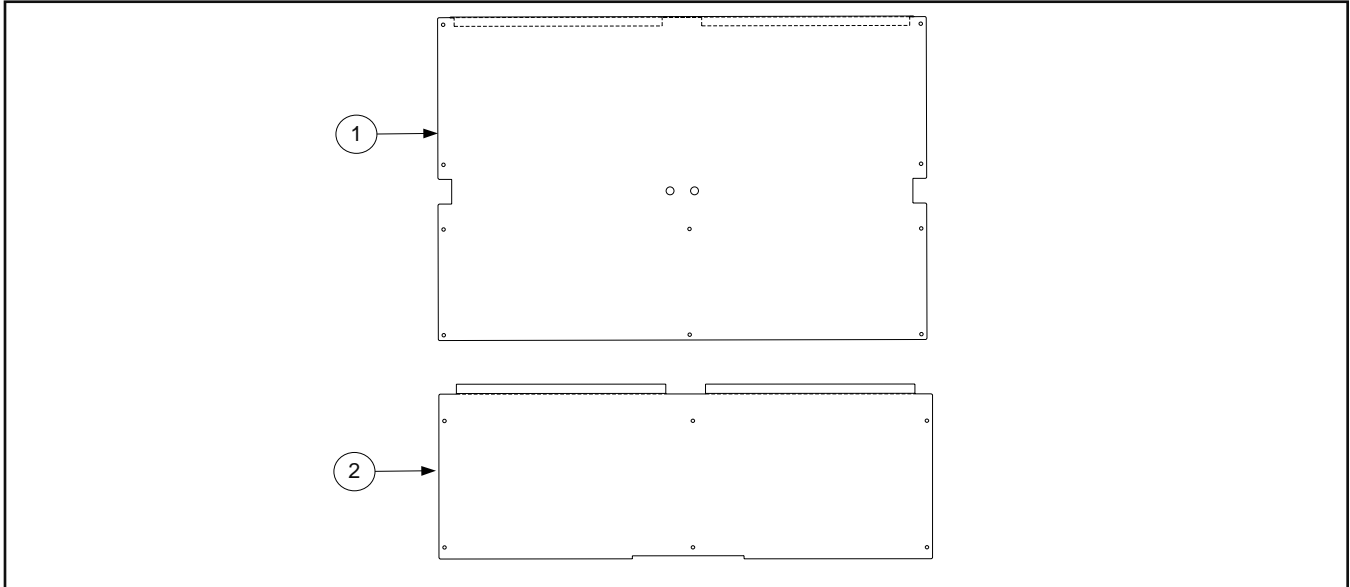

ITEM	PART #	COMPONENT
1		Upper Cabinet Backs
		Single Station Backs
	200-8886	2424 - DF4x# (32424/D60), DF6x1 (MJ-H2x5/FB24/32424)
**	220-0366	2424 - YUM
		Two Station Backs
	220-0093	D60/MJ-Hx5 - DF2x1 (SCFD160/MJ-H1x5CSC), DF2x2 (SCFD150/MJ-H1x5SC), DF2x3 (SCFD160/MJ-H1x5SC)
	200-8593	D250 - DF4x1 (MJ-H2x5/SCFD260), DF4x2 (MJ-H2x5/SCFD250), DF4x3 (SCFD250/MJ-H2x5), DF4x# (MJ245/21824), DF5x1 (MJ-H2x5/SCFD360), DF5x# (MJ-H2x5/D360), DF6x1 (MJ-H2x5/FB24/32424)
	230-0241*	D250/MJ-H2x5 - DF4x4 (MJ-H2x5SC/SCFD260)
	200-8458	D260 - DF4x1 (MJ-H2x5/SCFD260)
	230-0239*	D260 - DF4x4 (MJ-H2x5SC/SCFD260)
	200-8457	MJ-H2x5 - DF4x2 (MJ-H2x5/SCFD250)
	200-9781	21824 or FB/D60 - DF4x# (MJ-H2x5/21824), DF4x# (32424/D60)
	200-0481	22424- DF4x5 (MJ-H3x5/24MC/2424)
		Three Station Backs
	220-0413	D60/MJ-H2x5 - DF3x1 (D60/MJ-H2x5), DF2x5 (D160/15MC/MJ-H1x5)
	220-0337	MJ-Hx5/D60/1824 - DF3x# (MJ-Hx5/D60/1824)
	220-0440	MJ-H3x5-DF4x5 (MJ-H3x5/24MC/2424)
	200-8597	D360 - DF5x1 (MJ-H2x5/SCFD360), DF5x# (MJ-H2x5/D360)

* Stainless steel

** Not illustrated.

continued on next page...

2.5 Upper and Lower Back Panels cont.

ITEM	PART #	COMPONENT
2		Lower Cabinet Backs
		Single Station Backs
	200-8885	2424 - DF4x# (32424/D60), DF6x1 (MJ-H2x5/FB24/32424)
	220-0365	2424 - YUM
		Two Station Backs
	220-0091	D60/MJ-Hx5 - DF2x1 (SCFD160/MJ-H1x5CSC), DF2x2 (SCFD150/MJ-H1x5SC), DF2x3 (SCFD160/MJ-H1x5SC)
	200-8594	D250 - DF4x1 (MJ-H2x5/SCFD260), DF4x2 (MJ-H2x5/SCFD250), DF4x3 (SCFD250/MJ-H2x5), DF4x# (MJ245/21824), DF5x1 (MJ-H2x5/SCFD360), DF5x# (MJ-H2x5/D360), DF6x1 (MJ-H2x5/FB24/32424)
	230-0242*	D250/MJ-H2x5 - DF4x4 (MJ-H2x5SC/SCFD260)
	200-8595	D260 - DF4x1 (MJ-H2x5/SCFD260)
	230-0240*	D260 - DF4x4 (MJ-H2x5SC/SCFD260)
	200-8539	MJ-H2x5 - DF4x2 (MJ-H2x5/SCFD250)
	220-0180	21824 or FB/D60 - DF4x# (MJ-H2x5/21824), DF4x# (32424/D60)
	200-0179	22424- DF4x5 (MJ-H3x5/24MC/2424)
		Three Station Backs
	220-0412	D160/MJ-H2x5 - DF3x1 (D160/MJ-H2x5), DF2x5 (D160/MC/MJ-H1x5)
	220-0336	MJ-H1x5/D160/1824 - DF3x# (MJ-H1x5/D160/1824)
	220-0441	MJ-H3x5-DF4x5 (MJ-H3x5/24MC/2424)
	200-8596	D360 - DF5x1 (MJ-H2x5/SCFD360), DF5x# (MJ-H2x5/D360)

* Stainless Steel

2.6 Door Assemblies

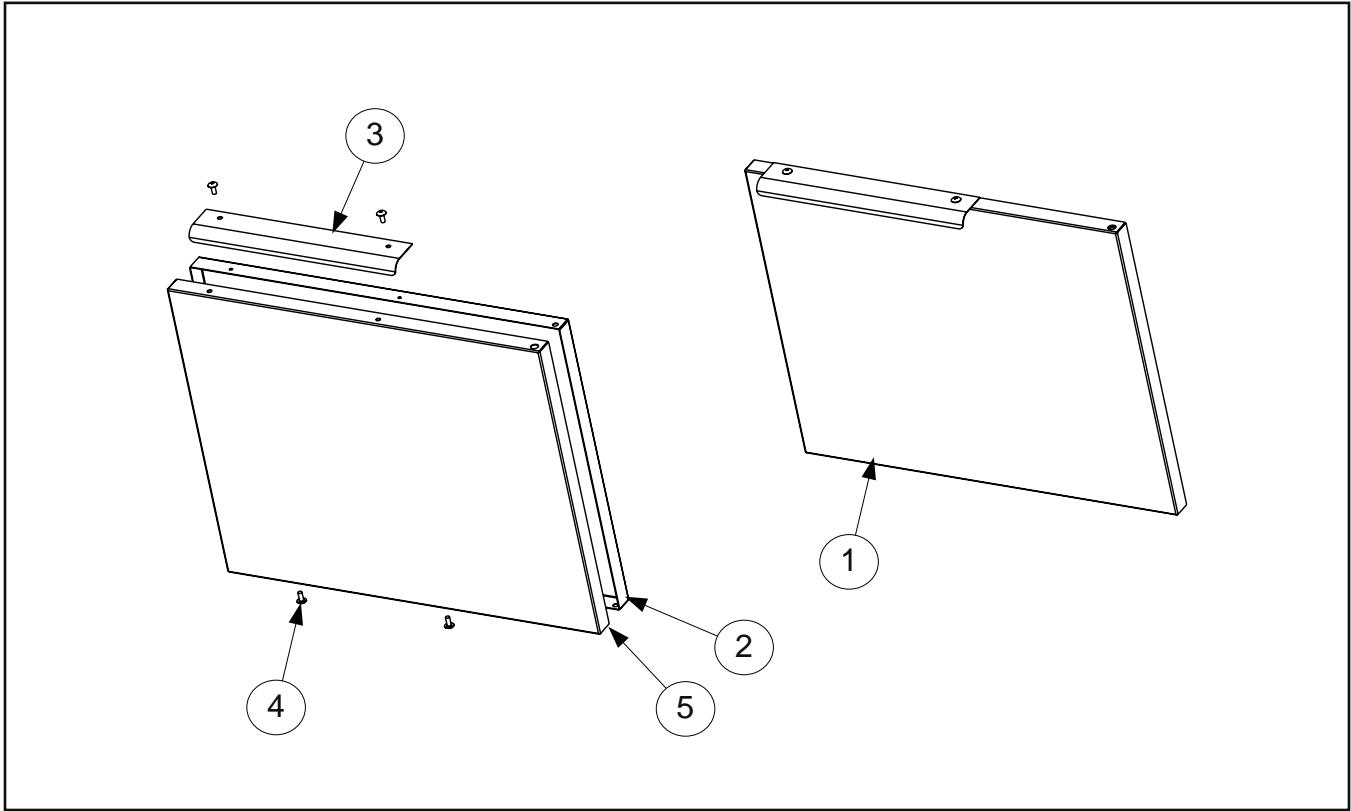

ITEM	PART #	COMPONENT
1		Door Assemblies
	106-3965	MJ35/45
	106-3966	H55
	106-4512	D50
	106-4309	D60, 1824
	106-5248	2424 Left
	106-4753	2424 Right
2		Panel, Liner
	200-6814	MJ35/45
	200-6822	H55
	200-8538	D50
	200-8076	D60, 1824
	200-8872	2424 Left, 2424 Right
3		Handle
	210-9739	MJ35/45, H55
	210-8077	D50, D60, 1824, 2424 Left, 2424 Right
4	809-0449	Screw #10 x 1/2" Phillips
5		Panel, Door
	824-1344	MJ35/45
	824-1342	H55
	824-1435	D50
	824-1386	D60, 1824
	824-1480	2424 Left, 2424 Right

2.7 Drain Assemblies

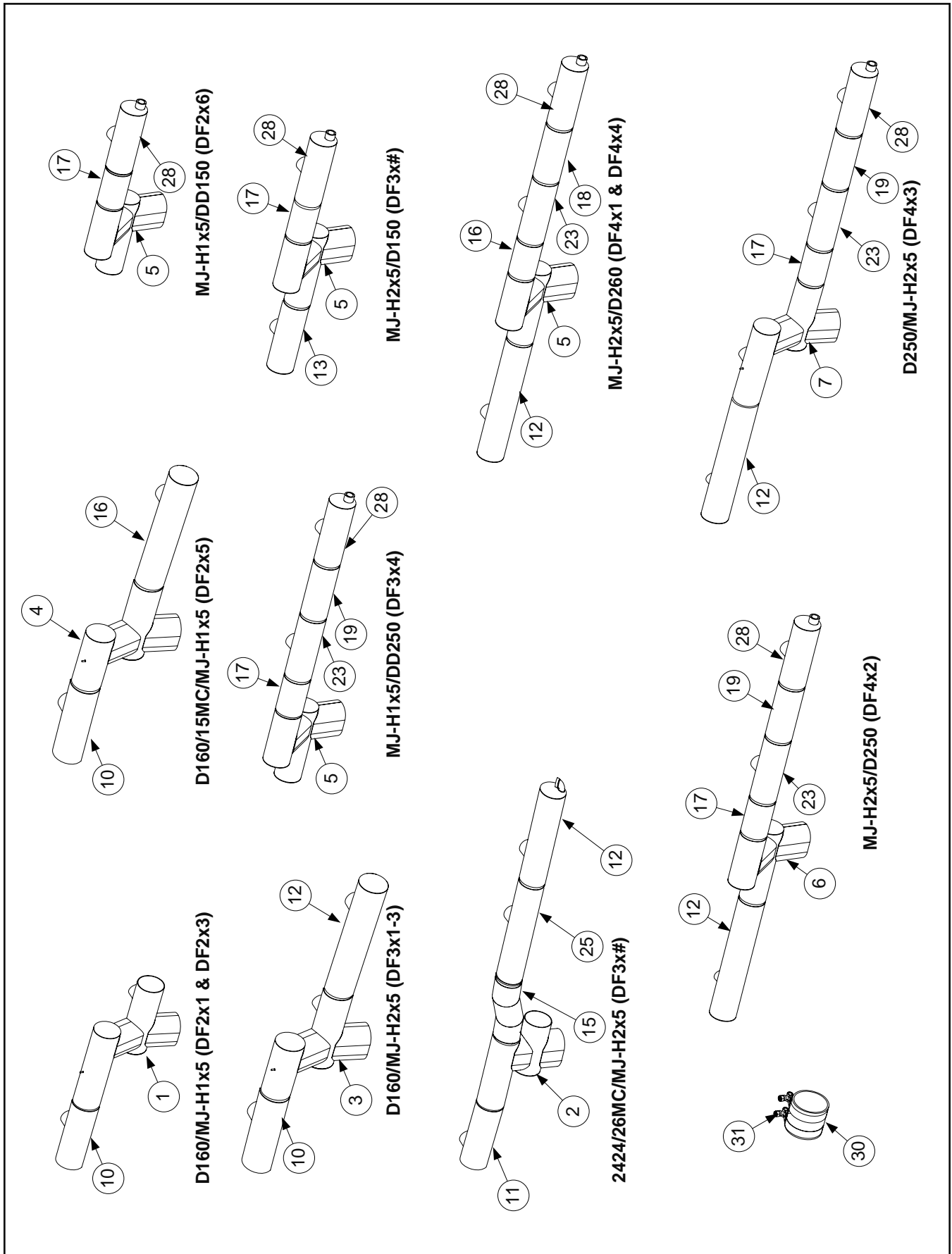

2.7 Drain Assemblies cont.

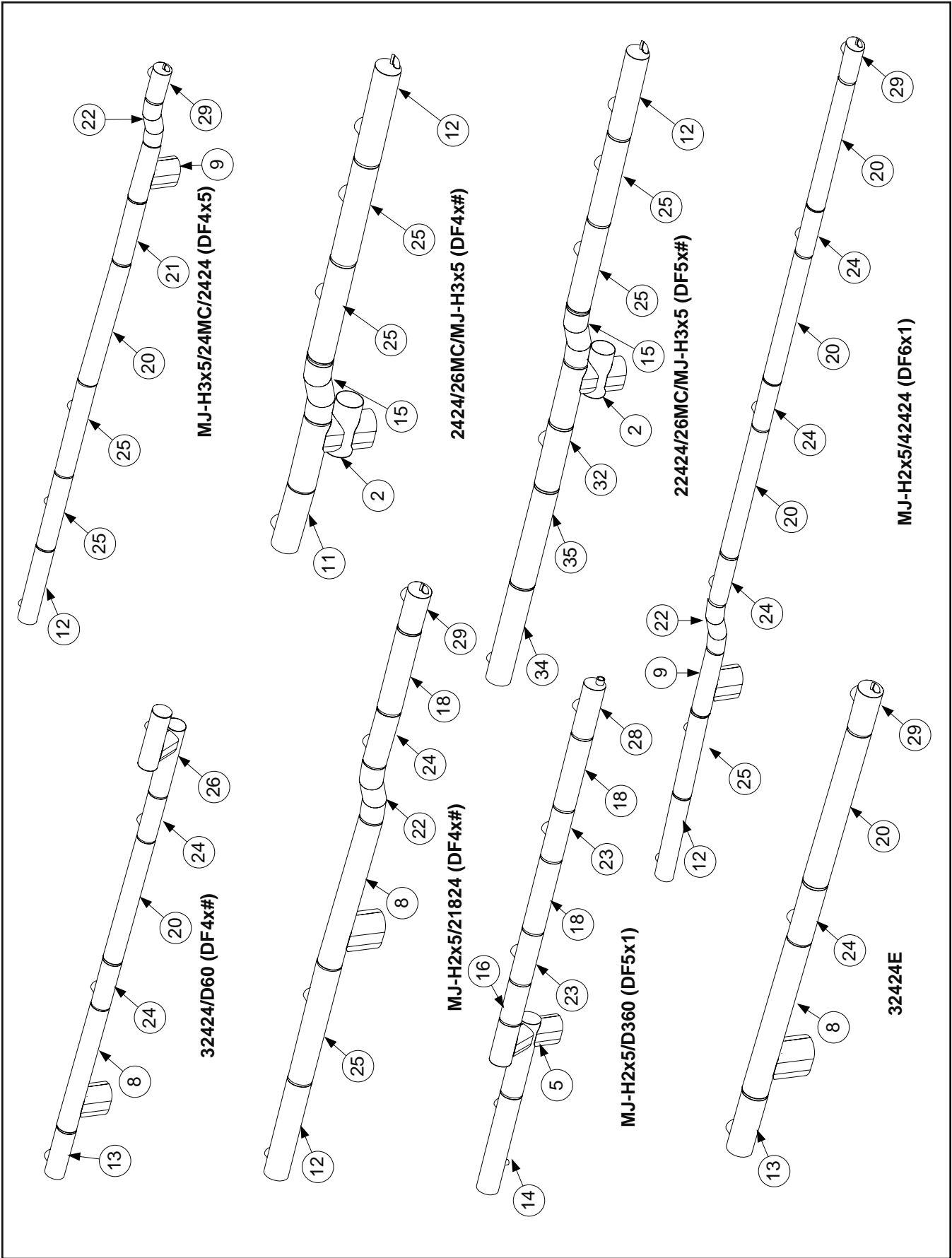

2.7 Drain Assemblies cont.

ITEM	PART #	COMPONENT
1	812-1880	Connector / Dump D60/MJ-Hx5 (823-5473)
2	812-1873	Connector / Dump 24MC/MJ-Hx5 (823-5984)
3	812-1881	Connector / Dump D60/MJ-Hx5 (823-5529)
4	812-1878	Connector / Dump D60/15MC/MJ-Hx5 (823-5938)
5	823-5046	Connector / Dump MJ-Hx / D60
6	823-4929	Connector / Dump MJ-Hx5/D50
7	812-1882	Connector / Dump D50/MJ-Hx5 (823-5464)
8	823-4876	Connector / Dump
9	823-4678	Connector / Dump
10	823-5506	Connecting Drain, Left/Upper D60/MJ-Hx5 - 7.0"
11	812-1876	Connecting Drain, Left/Upper 2424- 11.03" (823-5980)
12	823-4639	Connecting Drain, Left / Right - 15.55"
13	823-4853	Connecting Drain, Left - 9.06"
14	823-5066	Connecting Drain, Left MJ-Hx/D60 - 15.61"
15	812-1874	Connecting Drain, Center - 8.93" (823-5983)
16	200-8561	Connecting Drain, Center - 6.25"
17	200-8560	Connecting Drain, Center - 4.5"
18	200-6603	Connecting Drain, Center - 11.5"
19	200-6751	Connecting Drain, Center - 7.0"
20	200-8128	Connecting Drain, Center - 16.5"
21	200-0442	Connecting Drain, Center 24MC
22	823-5089	Connecting Drain, Center MJ-H2x5/FB - 8.05"
23	823-4682	Connecting Drain, Center 50/60/80 - 8.0"
24	823-4854	Connecting Drain, Center FB - 9.0"
25	823-4641	Connecting Drain, Center - 15.55"
26	823-5311	Connecting Drain, Right FB/D60
27	823-5474	Connecting Drain, Right MJ-Hx5/D60
28	823-4681	Connecting Drain, Right 50/60/80 - 8.06"
29	823-5084	Connecting Drain, Right FB - 4.0"
30	816-0625	Sleeve
31	809-0969	Clamp
*	816-0630	Vinyl Cap
32	812-1875	Connecting Drain, Center 22424/26MC - 10.97" (823-5990)
33	812-1879	Connector / Dump MJ-Hx5 / DD50 (823-5967)
34	823-5701	Connecting Drain, Left - 12.04"
35	220-2046	Connecting Drain, Center - 12.30"
*	811-1071	Tubing, Teflon Vent (sold by the foot)
*	KIT6214	3" Round Drain Boot Kit (includes 2 clamps and 1 sleeve)

* Not illustrated.

2.8 Drain Valve Assemblies

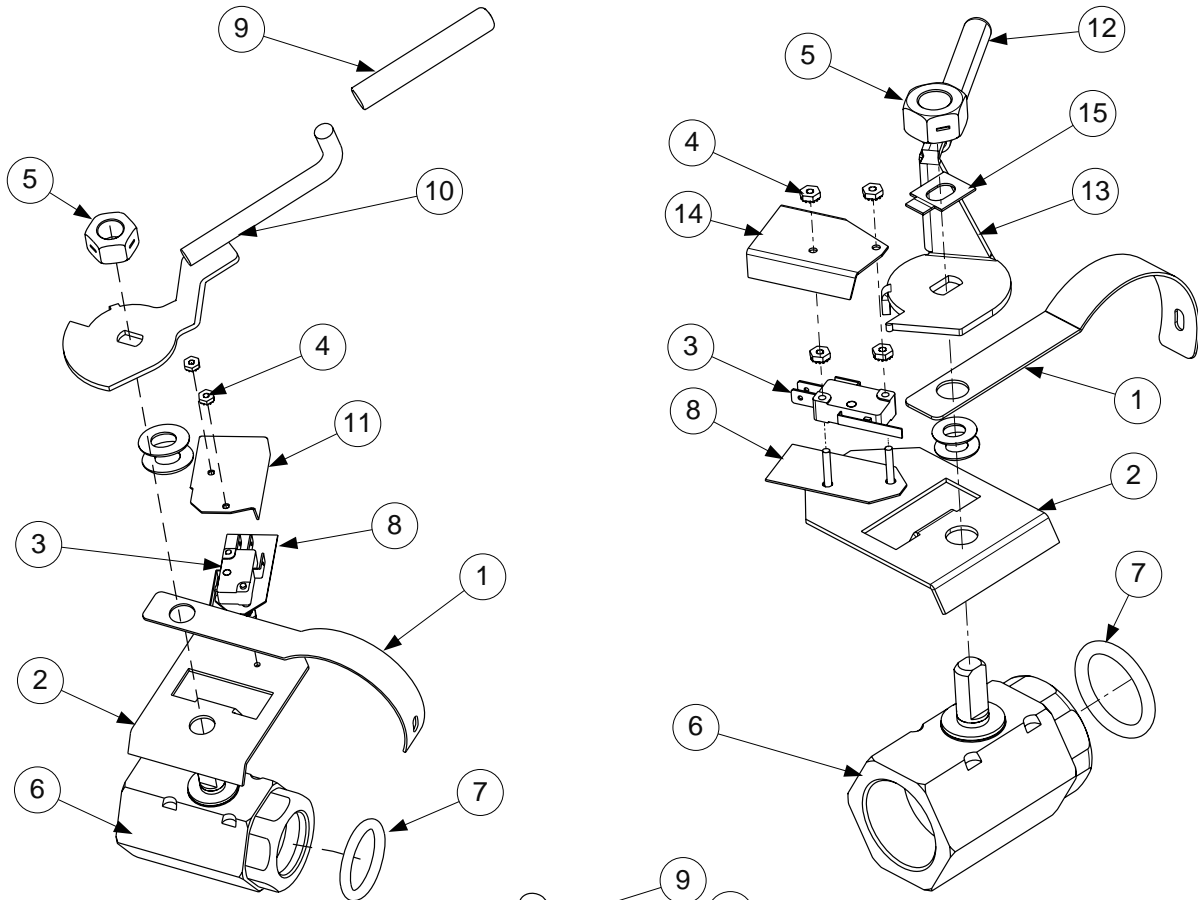

106-4690

106-1106

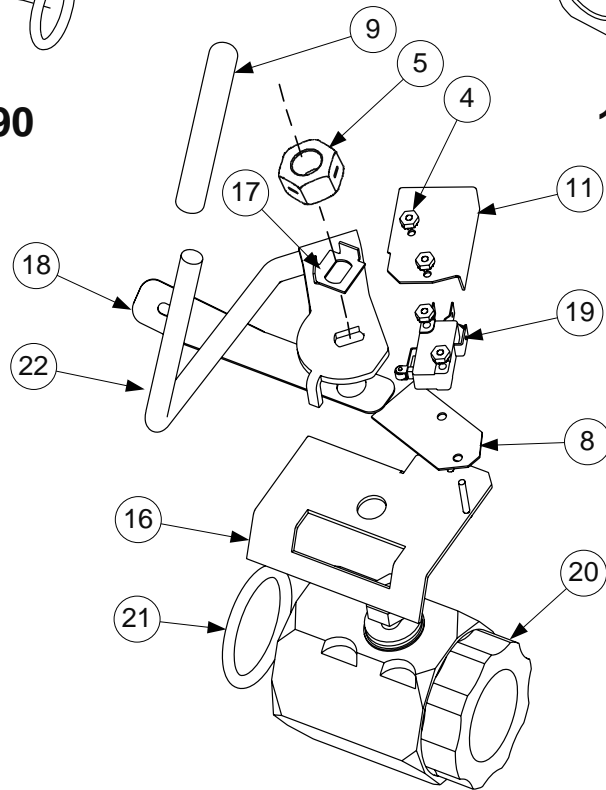

106-5430

2.8 Drain Valve Assemblies cont.

ITEM	PART #	COMPONENT
	106-4690	Drain Valve Assembly, MJ45/D50/D60
	106-1106	Drain Valve Assembly, H55
	106-5430	Drain Valve Assembly, Flatbottom
1	200-6496	Support, Drain Tube
2	806-8137	Bracket, Switch
3	807-2103	Switch, CE Micro Straight Lever
4	826-1366	Nut, 4-40 KEPS Hex (Qty. of 25)
5	809-0540	Nut, 2-Way Lock 1/2" - 13 ZN PL
6	810-1018	Valve, 1-1/4"
7	816-0135	O-Ring, Drain Valve
8	816-0220	Insulation, RF Switch
9	816-0547	Cap, Vinyl Red .375" x 3"
10	823-5064	Handle W/A, Drain Valve 45 Common Cabinet
11	901-2348	Cover, DV Safety Switch
12	816-0639	Cap, Vinyl Red 5/16" x 3"
13	824-1602	Handle W/A, Drain Valve Universal FV Elec.
14	900-2841	Cover, Switch Valve
15	900-2936	Retainer, Nut Drain Valve
16	106-3982	Bracket Assembly, 1-1/4" Microswitch
17	200-1257	Retainer, Nut Drain Valve
18	200-8867	Strap, 3" Drain 1-1/4" Valve
19	807-2104	Switch, CE Micro Roller Lever
20	810-2867	Valve, 1-1/4 Full Port w/o Ring FB Drain
21	816-0544	O-Ring, Drain Valve
22	823-4883	Handle W/A, Flatbottom 3" Drain Valve

2.9 Filter Pump Assemblies

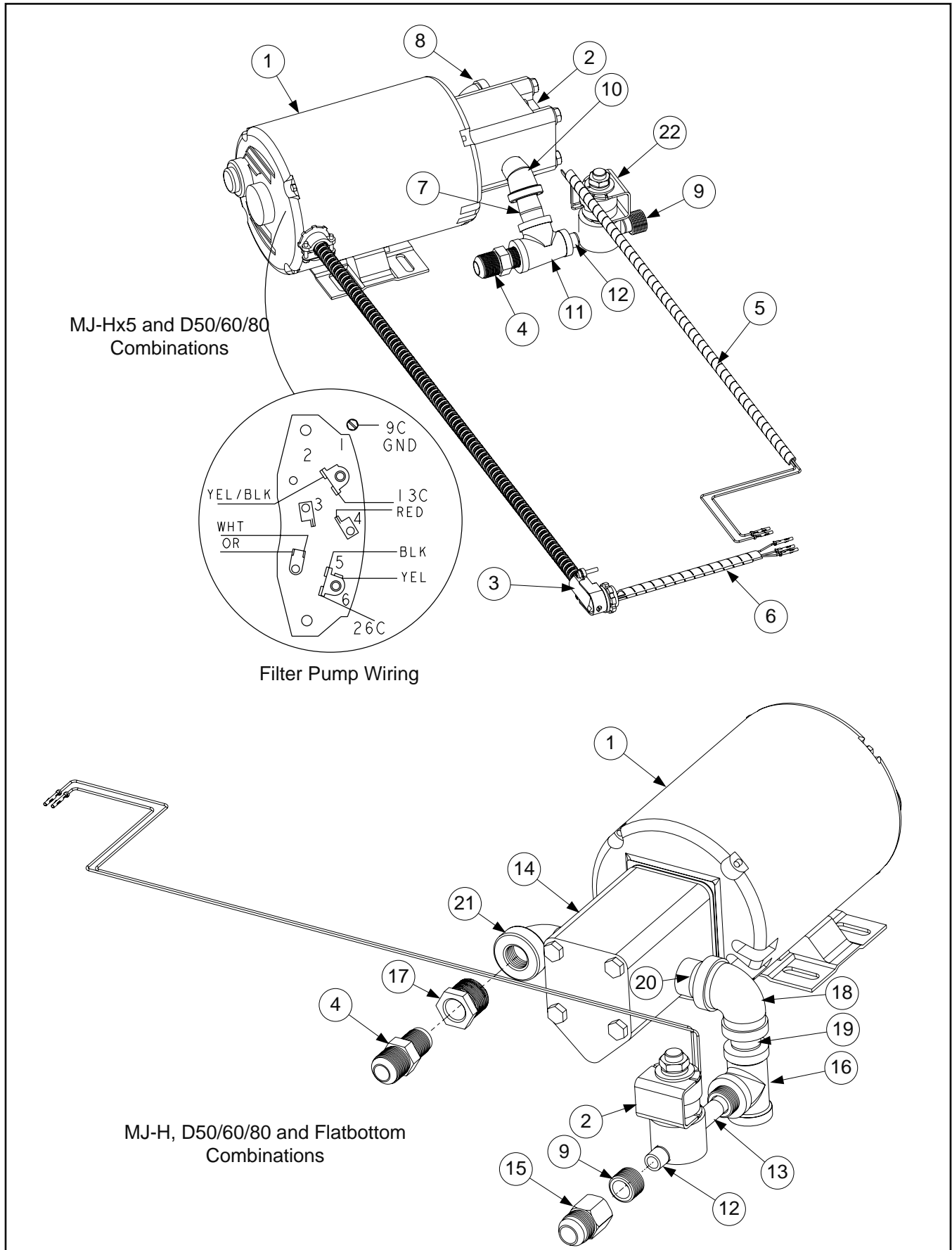

2.9 Filter Pump Assemblies cont.

ITEM	PART #	COMPONENT
		Pump and Motor Assembly 115V 60Hz
1	826-1712	Motor 115V 60Hz
2	826-1264	Pump and Gasket Kit, Viking 4GPM 2-piece
	816-0093	Gasket, Pump/Motor
3	106-5162	Pump, Wiring Assembly
4	810-1668	Adaptor, Male 5/8" OD x 1/2"
5	812-1497	Wrap, 3/8" x 20" Long Spiral
6	812-1500	Wrap, 3/8" x 6" Long Spiral
7	813-0022	Nipple, 1/2" x Close NPT BM
8	813-0165	Elbow, St. 1/2" x 1/2" NPT 90°
9	813-0304	Bushing, 1/2" x 1/4" BM Flush
10	813-0342	Elbow, Street 45° 1/2" NPT
11	813-0530	Tee, Reducing 1/2" x 1/4" x 1/2"
12	813-0838	Nipple, 1/4" NPT BM Close
13	813-0537	Nipple, 1/4" x 2" NPT BM
14	810-3071	Pump, Viking 8 GPM
	816-0093	Gasket, Pump/Motor
15	810-1669	Adapter, Female 7/8" OD x 1/2"
16	813-0003	Tee, 1/2" x 1/2" x 1/2" BM
17	813-0031	Bushing, HX 3/4" NPT x 1/2" BM
18	813-0068	Elbow, Reducing 3/4" x 1/2"
19	813-0087	Nipple, 1/2" x 1.50" NPT BM
20	813-0112	Nipple, 3/4" x 2.00" NPT BM
21	813-0168	Elbow, Street 90° 3/4" x 3/4" NPT BM
22	106-3470	Valve, Solenoid w/ Female Pins

2.10 Filter Plumbing

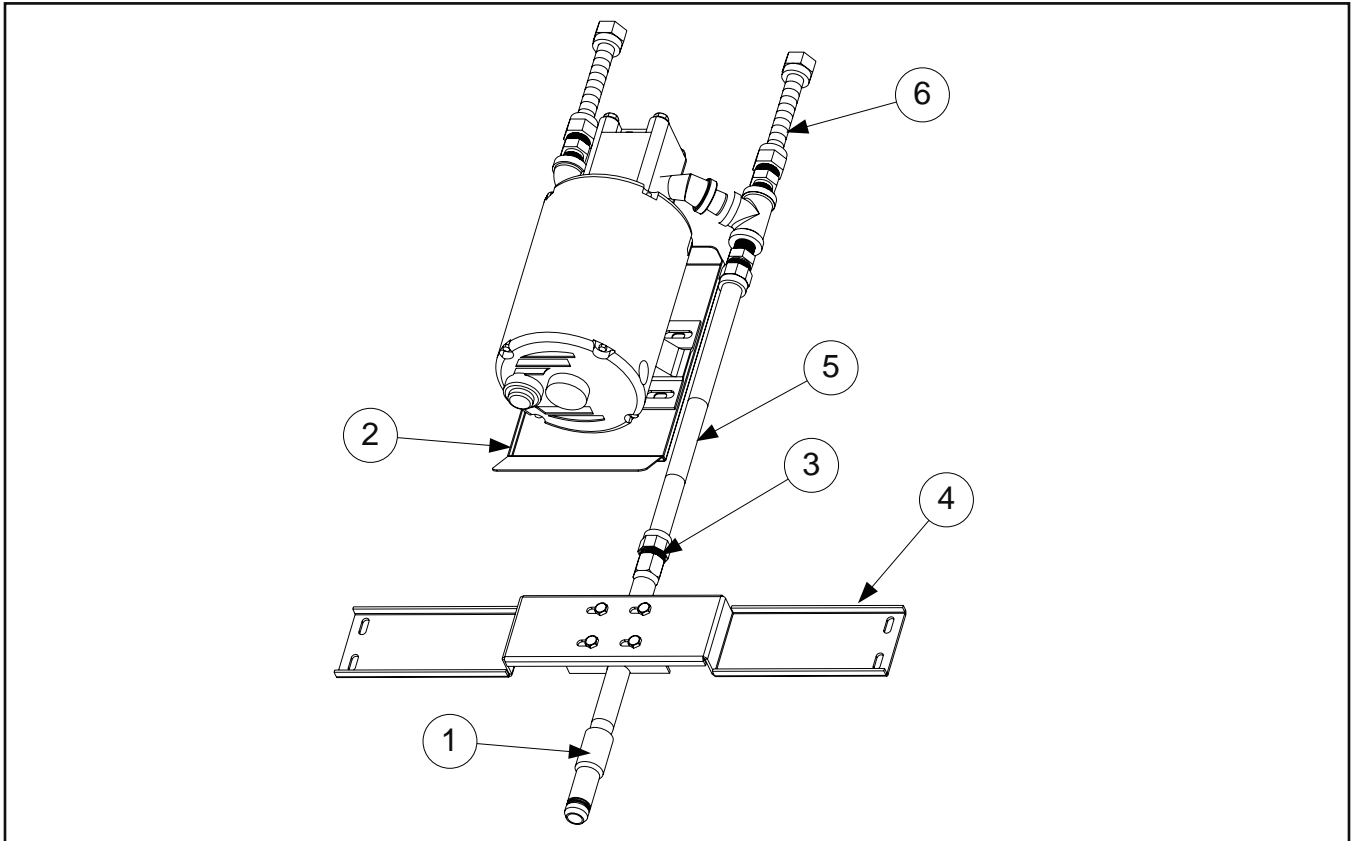

ITEM	PART #	COMPONENT
	106-6646	Plumbing Assembly, Filter
1	106-4427	Bracket Assembly, Suction Tube
2	824-1618	Plate Weldment, Filter Pump
3	810-1669	Adapter, Female 7/8 OD x 1/2"
4	200-8404	Bridge, Suction Tube
5	810-1057	Flexline 5/8" OD x 13.00"
6	810-1159	Flexline, 5.00" Oil Return

2.11 Filter Pan Assemblies

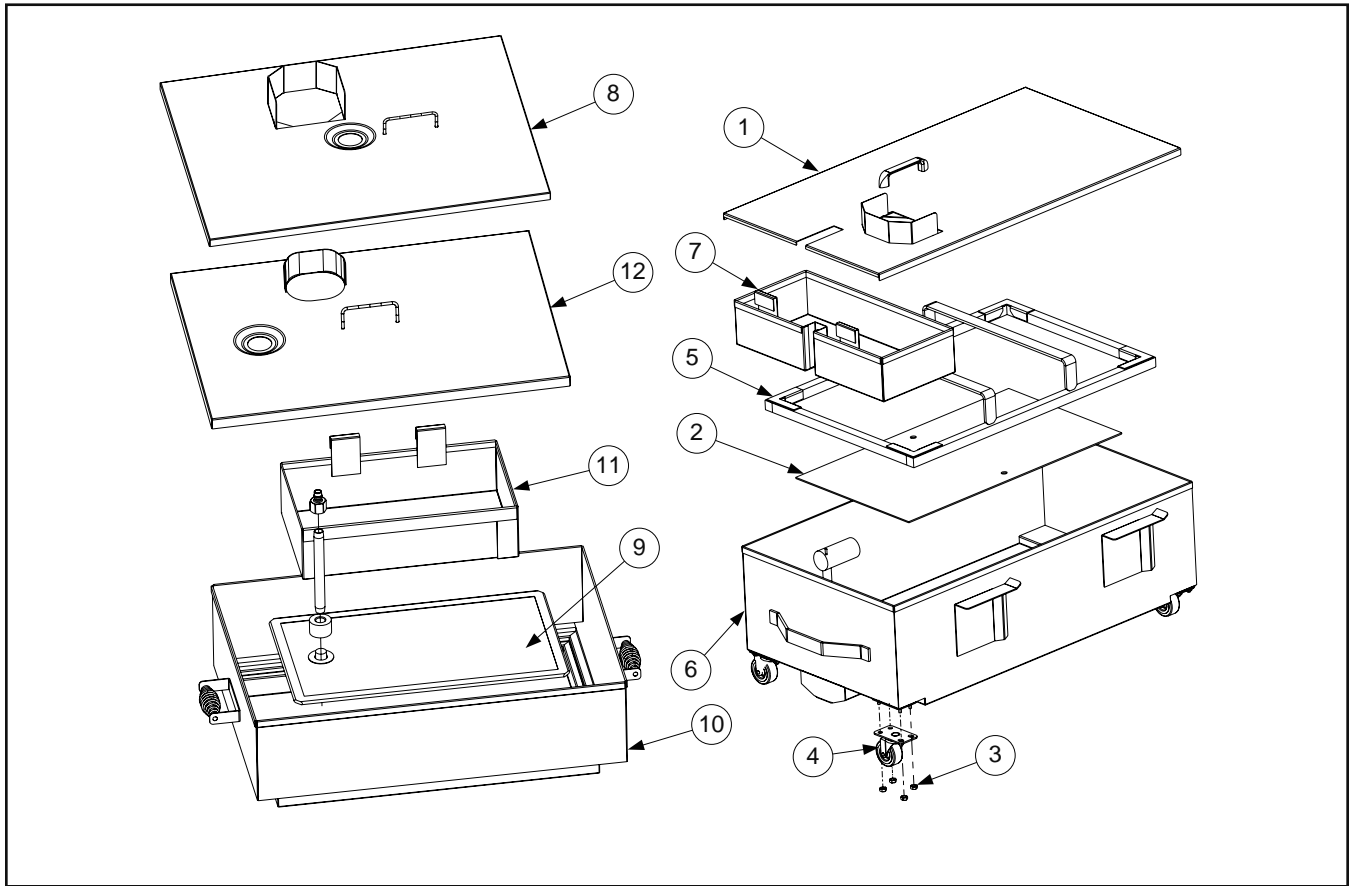

ITEM	PART #	COMPONENT
	106-5388	Filter Pan Assembly, Com Cab 60 Filter - MJ-Hx5 and D50/60 Combinations
	106-6130	Filter Pan Assembly, Flatbottom - Flatbottom Combinations (use 106-4720 for DF6x1)
1	106-5313	Lid Assembly - (fits Pan Assembly 106-5388)
2	200-5726	Screen, Sana Grid
3	809-0070	Nut, 1/4 - 20 HEX SS
4	810-2805	Caster, 2"
5	823-3361	Ring W/A, Hold Down
6	823-5138	Pan W/A, Com Cab 60 Filter (Pan for Assy 106-5388 and 106-4937)
*	823-5737	Pan W/A, Filter 2424 (Pan for Assy 106-6130)
7	823-5471	Basket W/A, Crumb Com Cab - (fits Pan Assy 106-5388)
8	823-5546	Lid Assembly - (fits Pan Assy 106-4720) 32424E
9	106-3675	Filter Screen Assembly, 2424
10	823-3480	Pan W/A, Flatbottom (Pan for Assy 106-4720)
11	823-5833	Basket W/A, Crumb - (fits Pan Assy 106-6130)
12	823-5090	Lid Assembly - (fits Pan Assy 106-4720) DF6x1
*	106-6131	Lid Assembly - (fits Pan Assy 106-6130)

* Not illustrated.

2.12 Transformer and Filter Box Assemblies

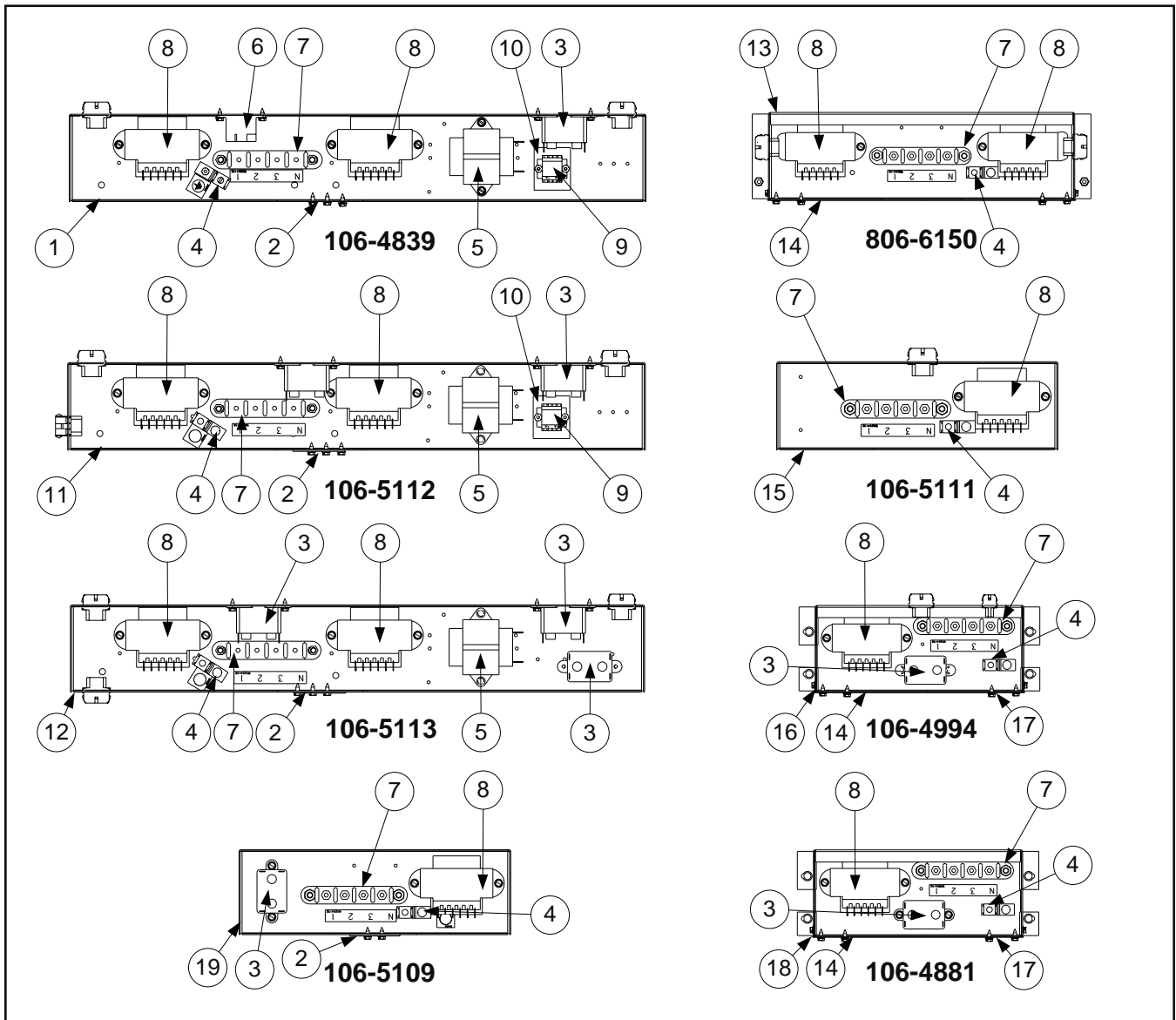

ITEM	PART #	COMPONENT
	106-4839	Box Assembly, Transformer/Filter Common Cabinet 2xx
	106-5112	Box Assembly, Transformer/Filter Tube/Flatbottom
	106-5113	Box Assembly, Transformer/Filter Flatbottom/Flatbottom
	806-6150	Box Assembly, Transformer 100/120V H255
	106-5111	Box Assembly, Transformer Tube/Open Single
	106-4881	Box Assembly, Transformer 1824/2424
	106-5109	Box Assembly, Transformer Flatbottom Single
	106-4994	Box Assembly, Filter 1824/2424
1	824-1242	Box, Weldment, Transformer FPP255
*	200-1415	Cover, Transformer Box FPP H55
2	200-6721	Plate, Strain Relief
3	807-0012	Relay, 18AMP 1/3 HP 24V Coil
4	807-0070	Terminal Ground Lug
5	807-0800	Transformer 120V/24VAC, 50/60 HZ, 50VA
6	807-1683	Relay, 12VDC

* Not illustrated.

2.12 Transformer and Filter Box Assemblies cont.

ITEM	PART #	COMPONENT
7	807-1973	Terminal Post
8	807-2176	Transformer V/T Dual Voltage
9	810-1164	Block, 1 PLC Screwless Terminal
10	816-0217	Paper, Insulating Terminal Block CE
11	824-1557	Box, Weldment, Tube/FB Filter
*	200-1415	Cover, FPP H55 Transformer Filter Box
12	824-1558	Box, Weldment, FB/FB and Filter
*	200-1415	Cover, FPP H55 Transformer Filter Box
13	900-2700	Box, Transformer H252
*	900-2702	Cover, H255 Transformer Box
14	900-2703	Cover, Transformer Box H155L, 255 L&R, 355L
15	824-1530	Box, Weldment, Transformer Common Cabinet
*	200-9392	Cover, Transformer Box Common Cabinet
16	200-9288	Box, Transformer 1824/2424 Common Cabinet
*	900-2708	Cover, H155 Transformer Box
17	900-2709	Cover, Transformer Box H355R
18	200-9049	Box, Transformer 1824/2424 Common Cabinet
*	900-2708	Cover, H155 Transformer Box
19	824-1551	Box W/A, Flatbottom Single
*	200-9392	Cover, Transformer Box Common Cabinet

* Not illustrated.



Frymaster[®]

Enodis[®]
One Company, Countless Solutions

Frymaster, L.L.C., 8700 Line Avenue, PO Box 51000, Shreveport, Louisiana 71135-1000
Shipping Address: 8700 Line Avenue, Shreveport, Louisiana 71106

TEL 1-318-865-1711 FAX (Parts) 1-318-219-7140 FAX (Tech Support) 1-318-219-7135

PRINTED IN THE UNITED STATES

SERVICE HOTLINE
1-800-551-8633

819-6153
SEPTEMBER 2006