

**SERVICE MANUAL
FRYMASTER MH52 AND BIH52 SERIES
GAS FRYERS**



This equipment chapter is to be installed in the Fryer Section of the *Equipment Manual*.

FOR YOUR SAFETY
Do Not Store or use gasoline or other flammable vapors and liquids in the vicinity of this or any other appliance.

**MANUFACTURED
BY
FRYMASTER, L.L.C.
P.O. BOX 51000
SHREVEPORT, LOUISIANA 71135-1000
PHONE: 1-318-865-1711
TOLL FREE: 1-800-551-8633
1-800-24 FRYER
FAX: 1-318-219-7135**



Frymaster, L.L.C. 8700 Line Avenue 71106, 5489 Campus Drive 71129
P.O. Box 51000, Shreveport, Louisiana 71135-1000
TEL 318-865-1711 FAX (Parts) 318-219-7140 (Tech Support) 318-219-7135

PRINTED IN THE UNITED STATES

**SERVICE HOTLINE
1-800-24-FRYER**

JUNE 2005
*** 8195423 ***

NOTICE

IF, DURING THE WARRANTY PERIOD, THE CUSTOMER USES A PART FOR THIS ENODIS EQUIPMENT OTHER THAN AN UNMODIFIED NEW OR RECYCLED PART PURCHASED DIRECTLY FROM FRYMASTER/DEAN, OR ANY OF ITS AUTHORIZED SERVICE CENTERS, AND/OR THE PART BEING USED IS MODIFIED FROM ITS ORIGINAL CONFIGURATION, THIS WARRANTY WILL BE VOID. FURTHER, FRYMASTER DEAN AND ITS AFFILIATES WILL NOT BE LIABLE FOR ANY CLAIMS, DAMAGES OR EXPENSES INCURRED BY THE CUSTOMER WHICH ARISE DIRECTLY OR INDIRECTLY, IN WHOLE OR IN PART, DUE TO THE INSTALLATION OF ANY MODIFIED PART AND/OR PART RECEIVED FROM AN UNAUTHORIZED SERVICE CENTER.

NOTICE

This appliance is intended for professional use only and is to be operated by qualified personnel only. A Frymaster/DEAN Factory Authorized Service Center (FASC) or other qualified professional should perform installation, maintenance, and repairs. Installation, maintenance, or repairs by unqualified personnel may void the manufacturer's warranty.

NOTICE

This equipment must be installed in accordance with the appropriate national and local codes of the country and/or region in which the appliance is installed.

NOTICE TO U.S. CUSTOMERS

This equipment is to be installed in compliance with the basic plumbing code of the Building Officials and Code Administrators International, Inc. (BOCA) and the Food Service Sanitation Manual of the U.S. Food and Drug Administration.

NOTICE

Drawings and photos used in this manual are intended to illustrate operational, cleaning and technical procedures and may not conform to onsite management operational procedures.

NOTICE TO OWNERS OF UNITS EQUIPPED WITH COMPUTERS

U.S.

This device complies with Part 15 of the FCC rules. Operation is subject to the following two conditions: 1) This device may not cause harmful interference, and 2) This device must accept any interference received, including interference that may cause undesired operation. While this device is a verified Class A device, it has been shown to meet the Class B limits.

CANADA

This digital apparatus does not exceed the Class A or B limits for radio noise emissions as set out by the ICES-003 standard of the Canadian Department of Communications.

Cet appareil numerique n'emet pas de bruits radioelectriques depassany les limites de classe A et B prescrites dans la norme NMB-003 edictee par le Ministre des Communcations du Canada.

 WARNING

To ensure the safe and efficient operation of the fryer and hood, the electrical plug for the 120-volt line, which powers the hood, must be fully engaged and locked in its pin and sleeve socket.

⚠ DANGER

Improper installation, adjustment, maintenance or service, and unauthorized alterations or modifications can cause property damage, injury, or death. Read the installation, operating, and service instructions thoroughly before installing or servicing this equipment. Only qualified service personnel may convert this appliance to use a gas other than that for which it was originally configured.

⚠ DANGER

No structural material on the fryer should be altered or removed to accommodate placement of the fryer under a hood. Questions? Call the Frymaster Dean Service Hotline at 1-800-551-8633.

⚠ DANGER

Adequate means must be provided to limit the movement of this appliance without depending upon the gas line connection. Single fryers equipped with legs must be stabilized by installing anchor straps. All fryers equipped with casters must be stabilized by installing restraining chains. If a flexible gas line is used, an additional restraining cable must be connected at all times when the fryer is in use.

⚠ DANGER

The front ledge of the fryer is not a step! Do not stand on the fryer. Serious injury can result from slips or contact with the hot oil.

⚠ DANGER

Do not store or use gasoline or other flammable liquids or vapors in the vicinity of this or any other appliance.

⚠ DANGER

Instructions to be followed in the event the operator smells gas or otherwise detects a gas leak must be posted in a prominent location. This information can be obtained from the local gas company or gas supplier.

⚠ DANGER

This product contains chemicals known to the state of California to cause cancer and/or birth defects or other reproductive harm.

Operation, installation, and servicing of this product could expose you to airborne particles of glasswool or ceramic fibers, crystalline silica, and/or carbon monoxide. Inhalation of airborne particles of glasswool or ceramic fibers is known to the State of California to cause cancer. Inhalation of carbon monoxide is known to the State of California to cause birth defects or other reproductive harm.

⚠ DANGER

The crumb tray in fryers equipped with a filter system must be emptied into a fireproof container at the end of frying operations each day. Some food particles can spontaneously combust if left soaking in certain shortening material.

⚠ WARNING

Do not bang fry baskets or other utensils on the fryer's joiner strip. The strip is present to seal the joint between the fry vessels. Banging fry baskets on the strip to dislodge shortening will distort the strip, adversely affecting its fit. It is designed for a tight fit and should only be removed for cleaning.

WARRANTY STATEMENT

The following applies to equipment sold to domestic (U.S.) markets. International warranty provisions will vary depending upon the country in which the equipment is sold. See your dealer for specific warranty provisions applicable to your location. For all international warranties, the customer is responsible for freight and duty charges.

Frymaster, L.L.C. makes the following limited warranties to the original purchaser only for this equipment and replacement parts:

A. WARRANTY PROVISIONS - FRYERS

1. Frymaster L.L.C. warrants all components against defects in material and workmanship for a period of one year.
2. All parts, with the exception of the frypot, heating elements and fuses, are warranted for one year after installation date of fryer.
3. If any parts, except fuses and filter O-rings, become defective during the first year after installation date, Frymaster will also pay straight-time labor costs to replace the part, plus up to 100 miles/160 km of travel (50 miles/80 km each way).

B. WARRANTY PROVISIONS - FRYPOTS

(Applies to fryers manufactured after December 1, 2003, only.)

1. If a frypot develops a leak within ten years after installation, Frymaster will, at its option, either replace the complete battery or replace the frypot, allowing up to the maximum time per the Frymaster time allowance chart hours of straight-time labor plus up to 100 miles/160 km of travel (50 miles/80 km each way) to change the frypot.
2. This warranty is limited to fryers operating on natural or propane (LP) gas. Fryers that operate on manufactured gas (also known as town gas or high-hydrogen gas) have a lifetime frypot warranty, parts only.

C. WARRANTY PROVISIONS – COMBUSTION CHAMBERS

(Applies to fryers installed on or after November 1, 1994, only.)

1. Frymaster L.L.C. warrants the combustion chambers against defective material or workmanship for a period of ten years from the original installation date, parts and labor.
2. The combustion chamber consists of the infrared burners and the structural components to mount the burners. This warranty does not cover ancillary components, including the igniter, blower, high-limit thermostat, and temperature probe.
3. This warranty is limited to fryers operating on natural or propane (LP) gas.

D. WARRANTY PROVISIONS - COOKING COMPUTER

1. Frymaster L.L.C. warrants the M-2000 Cooking Computer against defective material or workmanship for a period of three years from the original installation date. If the unit fails within the first year, warranty will cover part, labor and handling. If the part fails the second year, warranty will cover part and handling only. Labor is charged to the store. The third year, warranty will cover the part only. No labor or handling will be covered.
2. During this warranty period, Frymaster will, at its option, repair or replace a returned defective cooking computer with a new or factory rebuilt and functionally operative units.
3. For replacement of defective computers under warranty, call your local Frymaster Authorized Service Center. All computers replaced under the Frymaster exchange program are covered by a one-year (parts only) warranty.

E. PARTS RETURN

All defective in-warranty parts must be returned to a Frymaster Authorized Factory Service Center within 60 days for credit. After 60 days, no credit will be allowed.

F. WARRANTY EXCLUSIONS

This warranty does not cover equipment that has been damaged due to misuse, abuse, alteration, or accident such as:

- improper or unauthorized repair (including any frypot which is welded in the field);
- failure to follow proper installation instructions and/or scheduled maintenance procedures as prescribed in your MRC cards. Proof of scheduled maintenance is required to maintain the warranty;
- improper maintenance;
- damage in shipment;
- abnormal use;
- removal, alteration, or obliteration of either the rating plate or the date code on the heating elements;
- operating the frypot without shortening or other liquid in the frypot;
- no fryer will be warranted under the ten-year program for which a proper start-up form has not been received.

This warranty also does not cover:

- transportation or travel over 100 miles/160 km (50 miles/80 km each way), or travel over two hours;
- overtime or holiday charges;
- consequential damages (the cost of repairing or replacing other property which is damaged), loss of time, profits, use or any other incidental damages of any kind.

There are no implied warranties of merchantability or fitness for any particular use or purpose.

**BIH52 / MH52
SERIES GAS FRYERS
TABLE OF CONTENTS**

CHAPTER 1: Introduction

1.1	General	1-1
1.2	Safety Information.....	1-1
1.3	Computer Information	1-2
1.4	European Community (CE) Specific Information.....	1-2

CHAPTER 2: Installation Instructions

2.1	General Installation Requirements	2-1
2.2	Caster/Leg Installation	2-3
2.3	Pre-Connection Preparations	2-3
2.4	Connections to Gas Line	2-5
2.5	Converting to Another Gas Type	2-7
2.6	Frypot Boil-Out	2-8

CHAPTER 3: Service Procedures, Troubleshooting and Wire Diagrams

3.1	Functional Description	3-1
3.2	Accessing Fryers for Servicing	3-5
3.3	Cleaning the Gas Valve Vent Tube	3-5
3.4	Checking the Burner Manifold Gas Pressure	3-6
3.5	Measuring Flame Current.....	3-8
3.6	Replacing Fryer Components	3-8
3.6.1	Replacing the Controller or the Controller Wiring Harness.....	3-8
3.6.2	Replacing the Temperature Probe or High-Limit Thermostat	3-9
3.6.3	Replacing the Interface Board	3-10
3.6.4	Replacing an Ignition Module	3-10
3.6.5	Replacing an Ignitor Assembly	3-10
3.6.6	Replacing or Cleaning a Combustion Air Blower.....	3-11
3.6.7	Replacing a Gas Valve	3-14
3.6.8	Replacing a Burner Assembly.....	3-14
3.6.9	Replacing the Frypot	3-15
3.6.10	Replacing Frypot Insulation and/or Upper Burner Rails.....	3-17
3.7	Troubleshooting and Problem Isolation	3-21
3.7.1	Ignition Failure	3-22
3.7.2	Improper Burner Function.....	3-23
3.7.3	Improper Temperature Control	3-24
3.7.4	Recovery Time and the M100B “Rec Loc” Condition	3-25
3.7.5	Filtration Malfunctions.....	3-26
3.7.6	Leakage	3-29
3.8	Troubleshooting Guides	3-29
3.8.1	Troubleshooting the 24 VAC Circuit	3-30
3.8.2	Troubleshooting the Gas Valve	3-33
3.8.3	Troubleshooting the Temperature Probe.....	3-34

**BIH52 / MH52
SERIES GAS FRYERS
TABLE OF CONTENTS**

3.9	Probe Resistance Chart.....	3-35
3.10	Simplified Wiring Diagrams	3-37
3.11	Principle Wiring Connections	3-42
3.12	Main Wiring Diagrams.....	3-43

CHAPTER 4: Parts List

4.1	Accessories.....	4-1
4.2	Cabinetry Components	4-2
4.2.1	BIH152 and MH152 Cabinet Components	4-2
4.2.2	BIH52 Cabinet Components	4-4
4.2.3	MH52 Cabinet Components.....	4-6
4.2.4	BIH52/MH52 Cap N Splash, Fluecaps, Standoffs and Related Parts	4-9
4.2.5	BIH52/MH52 Control Panel Frames and Topcaps	4-11
4.2.6	BIH52/MH52 Door Components	4-12
4.3	Combustion System, Frypot and Gas System Components	4-13
4.3.1	Blowers and Associated Parts	4-13
4.3.2	Ignition Sub-System Components.....	4-14
4.3.3	Frypot Assembly Components	4-15
4.3.3.1	Full Vat Frypot Assembly Components	4-15
4.3.3.2	Dual Vat Frypot Assembly Components	4-17
4.3.4	Service Frypot Kits.....	4-19
4.3.5	Gas Manifolds – Single BIH52/MH52 Units	4-20
4.3.6	Gas Manifolds – BIH52/MH52 Multi-Fryer Units	4-21
4.3.7	Gas Valves, Gas Lines and Fittings.....	4-23
4.4	Electronics	4-25
4.4.1	Computers, Controllers and Associated Components.....	4-25
4.4.2	Component Boxes	4-27
4.4.3	Filter Box Components	4-28
4.4.4	Transformer Box Components	4-29
4.4.5	Wiring.....	4-31
4.5	Oil Handling System Components	4-34
4.5.1	Drain System Components.....	4-34
4.5.1.1	Square Drain Sections and Components.....	4-34
4.5.1.2	Drain Valve Assemblies	4-35
4.5.2	Filtration System Components	4-37
4.5.2.1	Filter Base Assemblies.....	4-37
4.5.2.2	Filter Motor and Pump Plumbing	4-39
4.5.2.3	Filter Pan Assemblies and Associated Components.....	4-41
4.5.2.4	Rear Flush Oil Return Components.....	4-43

CHAPTER 1: INTRODUCTION

1.1 General

Read the instructions in this manual thoroughly before attempting to service this equipment. This manual covers all configurations of models MH52 and BIH52 fryers built since December 1995. Models designated MH52 do not have built-in filtration systems. Models designated BIH52 are equipped with FootPrint III built-in filtration systems.

H52 Series fryers feature deep cold-zones and easy to clean open frypots. The fryers are controlled by multi-product cooking computers or optional thermostat controllers. Fryers in this series come in full or split-pot arrangements, and can be purchased as single units or grouped in batteries of up to five fryers.

1.2 Safety Information

Before attempting to service this equipment, read the instructions in this manual thoroughly.

Throughout this manual, you will find notations enclosed in double-bordered boxes similar to the ones below.

CAUTION boxes contain information about actions or conditions that *may cause or result in a malfunction of the system.*



WARNING boxes contain information about actions or conditions that *may cause or result in damage to the system,* and which may cause the system to malfunction.



DANGER boxes contain information about actions or conditions that *may cause or result in injury to personnel,* and which may cause damage to your system and/or cause the system to malfunction.



Fryers in this series are equipped with automatic safety features:

1. A high-limit thermostat causes the gas valve to close should the controlling thermostat fail or computer temperature probe fail.
2. In BIH52 fryers, a safety switch built into the drain valve prevents the gas valve from opening with the drain valve even partially open.

1.3 Computer Information

This equipment has been tested and found to comply with the limits for a Class A digital device, pursuant to Part 15 of the FCC rules. While this device is a verified Class A device, it has been shown to meet the Class B limits. These limits are designed to provide reasonable protection against harmful interference when the equipment is operated in a commercial environment. This equipment generates, uses and can radiate radio frequency energy and, if not installed and used in accordance with the instruction manual, may cause harmful interference to radio communications. Operation of the equipment in a residential area is likely to cause harmful interference in which case the user will be required to correct the interference at his own expense.

The user is cautioned that any changes or modifications not expressly approved by the party responsible for compliance could void the user's authority to operate the equipment.

If necessary, the user should consult the dealer or an experienced radio and television technician for additional suggestions.

The user may find the following booklet prepared by the Federal Communications Commission helpful: "How to Identify and Resolve Radio-TV Interference Problems". This booklet is available from the U.S. Government Printing Office, Washington, DC 20402, Stock No. 004-000-00345-4.

1.4 European Community (CE) Specific Information

The European Community (CE) has established certain specific standards regarding equipment of this type. Whenever a difference exists between CE and non-CE standards, the information or instructions concerned are identified by means of shadowed boxes similar to the one below.

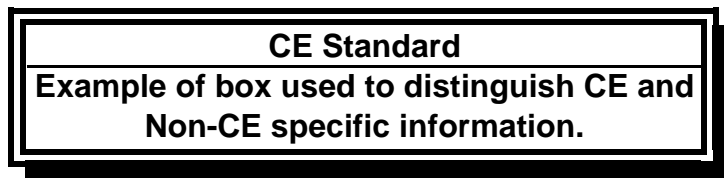

CHAPTER 2: INSTALLATION INSTRUCTIONS

2.1 General Installation Requirements

NOTE: PROPER INSTALLATION IS ESSENTIAL FOR EFFICIENT, TROUBLE-FREE OPERATION OF YOUR FRYER. ANY UNAUTHORIZED ALTERATIONS MADE TO THIS EQUIPMENT WILL VOID THE FRYMASTER WARRANTY.

Upon arrival, inspect the fryer carefully for visible or concealed damage. (See **Shipping Damage Claim Procedure** in Chapter 1.)

CLEARANCE AND VENTILATION

The fryer(s) must be installed with a 6” (150 mm) clearance at both sides and back when installed adjacent to combustible construction; no clearance is required when installed adjacent to noncombustible construction. A minimum of 24” (600 mm) clearance should be provided at the front of the fryer.

One of the most important considerations of efficient fryer operation is ventilation. Make sure the fryer is installed so that products of combustion are removed efficiently, and that the kitchen ventilation system does not produce drafts that interfere with proper burner operation.

The fryer flue opening must not be placed close to the intake of the exhaust fan, and the fryer must never have its flue extended in a “chimney” fashion. An extended flue will change the combustion characteristics of the fryer, causing longer recovery time. It also frequently causes delayed ignition. To provide the airflow necessary for good combustion and burner operation, the areas surrounding the fryer front, sides, and rear must be kept clear and unobstructed.

Fryers must be installed in an area with an adequate air supply and adequate ventilation. Adequate distances must be maintained from the flue outlet of the fryer to the lower edge of the ventilation filter bank. Filters should be installed at an angle of 45°. Place a drip tray beneath the lowest edge of the filter. For U.S. installation, NFPA standard No. 96 states, “A minimum distance of 18 in. (450 mm) should be maintained between the flue outlet and the lower edge of the grease filter.” *Frymaster recommends that the minimum distance be 24 in. (600 mm) from the flue outlet to the bottom edge of the filter when the appliance consumes more than 120,000 BTU per hour.*

For installations in the United States, information on construction and installation of ventilating hoods can be found in the NFPA standard cited above. A copy of the standard may be obtained from the National Fire Protection Association, Battery March Park, Quincy, MA 02269.

 **DANGER**

Do not attach an apron drainboard to a single fryer. The fryer may become unstable, tip over, and cause injury. The appliance area must be kept free and clear of combustible material at all times.

NATIONAL CODE REQUIREMENTS

The type of gas for which the fryer is equipped is stamped on the data plate attached to the inside of the fryer door. Connect a fryer stamped “NAT” only to natural gas, those stamped “PRO” only to propane gas, and those stamped “MFG” only to manufactured gas.

Installation shall be made with a gas connector that complies with national and local codes, and, where applicable, CE codes. Quick-disconnect devices, if used, shall likewise comply with national, local, and, if applicable, CE codes.

ELECTRICAL GROUNDING REQUIREMENTS

All electrically operated appliances must be grounded in accordance with all applicable national and local codes, and, where applicable, CE codes. A wiring diagram is located on the inside of the fryer door. Refer to the rating plate on the inside of the fryer door for proper voltages.

DANGER

If this appliance is equipped with a three-prong (grounding) plug, it must be plugged directly into a properly grounded receptacle.

Do not cut or remove the grounding prong from the plug.

DANGER

This equipment requires electrical power for operation.

Place the gas control valve in the OFF position in case of a prolonged power outage.

Do not attempt to use the equipment during a power outage.

FCC COMPLIANCE

The user is cautioned that any changes or modifications to Frymaster computers not expressly approved by the party responsible for compliance could void the user’s authority to operate the equipment.

Frymaster computers have been tested and found to comply with the limits for a Class A digital device, pursuant to Part 15 of the FCC rules. While these devices are verified as Class A devices, they have been shown to meet the Class B limits. These limits are designed to provide reasonable protection against harmful interference when the equipment is operated in a commercial environment. This equipment generates, uses, and can radiate radio frequency energy and, if not installed and used in accordance with the instruction manual, may cause harmful interference to radio communications. Operation of the equipment in a residential area is likely to cause harmful interference in which case the user will be required to correct the interference at his own expense.

If necessary, the user should consult the dealer or an experienced radio and television technician for additional suggestions.

The user may find the booklet “How to Identify and Resolve Radio-TV Interference Problems” helpful. It is prepared by the Federal Communications Commission and is available from the U.S. Government Printing Office, Washington, DC 20402, Stock No. 004-000-00345-4.

2.2 Caster/Leg Installation

Depending upon the specific configuration ordered, your fryer may have been shipped without installed casters or legs. If casters or legs are installed, you may skip this section and proceed to section 2.3, Pre-Connection Preparations.

If your fryer requires the installation of casters/legs, install them in accordance with the instructions included in your accessory package.

2.3 Pre-Connection Preparations



After the fryer has been positioned under the fry station exhaust hood, ensure the following has been accomplished:

1. Adequate means must be provided to limit the movement of fryers without depending upon the gas line connections. If a flexible gas hose is used, a restraining cable must be connected at all times when the fryer is in use. The restraining cable and installation instructions are packed with the flexible hose in the accessories box that was shipped with your unit.
2. **Single unit** fryers must be stabilized by installing restraining chains on fryers equipped with casters or anchor straps on fryers equipped with legs. Follow the instructions shipped with the casters/legs to properly install the chains or straps.
3. Level the fryer, if necessary, by loosening the locking screw on the caster legs and rotating the leg to increase or decrease the exposed length. Verify that the fryer is at the proper height in the exhaust hood. Frymaster recommends that the minimum distance from the flue outlet to the bottom edge of the hood be 24 in. (600 mm) when the appliance consumes more than 120,000 BTU per hour.
4. Test the fryer electrical system:
 - a. Plug the fryer electrical cord(s) into a grounded electrical receptacle.
 - b. Place the power switch in the **ON** position.
 - For fryers equipped with thermostat controls, note the illumination of the power light and the heat light.
 - For fryers having computers, note that the display reads **LO-TEMP** and the heat light comes on.
 - If the store is equipped with a hood interlock system, the hood exhaust fan should be on. If not, the store hood interlock system is improperly wired and must be corrected.

- c. Place the fryer power switch in the **OFF** position. Verify that the power and heat lights are out, or that the display shows “OFF”.
5. Refer to the data plate on the inside of the fryer door to determine if the fryer burner is configured for the proper type of gas before connecting the fryer quick-disconnect device or piping from the gas supply line.
6. Verify the minimum and maximum gas supply pressures for the type of gas to be used in accordance with the accompanying tables.

CE Standard for Incoming Gas Pressures for Fryers Manufactured After April 1999					
Gas	Pressure (mbar)⁽¹⁾	Orifice Diameter		Regulator Pressure	
		Single Vat	Dual Vat	Single Vat	Dual Vat
G20	20	2 x 3.40	2 x 3.40	7 mbar	6.5 mbar
G25	20 or 25	2 x 3.40	2 x 3.40	10 mbar	9 mbar
G30	28/30 or 50	2 x 2.05	2 x 2.05	17 mbar	17 mbar
G31	37 or 50	2 x 2.05	2 x 2.05	20 mbar	18.5 mbar

(1) mbar = 10.2 mm H₂O

CE Standard for Incoming Gas Pressures for Fryers Manufactured Through April 1999					
Gas	Pressure (mbar)⁽¹⁾	Orifice Diameter		Regulator Pressure	
		Single Vat	Dual Vat	Single Vat	Dual Vat
G20	20	2 x 3.40	2 x 3.40	7 mbar	6.5 mbar
G25	20 - 25	2 x 3.40	2 x 3.40	10 mbar	9 mbar
G31	37 - 50	2 x 2.05	2 x 2.05	20.2 mbar	18.5 mbar

(1) mbar = 10.2 mm H₂O

Non-CE Standard for Incoming Gas Pressures		
Gas	Minimum	Maximum
Natural	6" W.C.	14" W.C.
	1.49 kPa	3.48 kPa
	14.93 mbar	34.84 mbar
LP	11" W.C.	14" W.C.
	2.74 kPa	3.48 kPa
	27.37 mbar	34.84 mbar

2.4 Connection to Gas Line

The H52 Series has received the CE mark for the countries and gas categories indicated in the accompanying table. **NOTE:** The nominal heat input (Qn) is 21kW except for AT, DE, LU, and for category 3B/P under 50 mbar, which is 23kW.

CE Approved Gas Categories by Country*			
COUNTRIES	CATEGORIES	GAS	PRESSURE (mbar)
AUSTRIA (AT)	II _{2H3B/P}	G20	20
		G30, G31	50
BELGIUM (BE)	I _{2E(R)B}	G20, G25	20, 25
	I ₃₊	G30, G31	28-30, 37
DENMARK (DK)	II _{2H3B/P}	G20	20
		G30, G31	30
FRANCE (FR)	II _{2Esi3+}	G20, G25	20, 25
		G30, G31	28-30, 37
	II _{2Esi3P}	G20, G25	20, 25
		G31	50
FINLAND (FI)	II _{2H3B/P}	G20	20
		G30, G31	30
GERMANY (DE)	II _{2ELL3B/P}	G20, G25	20
		G30, G31	50
	I _{3P}	G31	50
GREECE (GR)	II _{2H3+}	G20	20
		G30, G31	28-30, 37
ITALY (IT)	II _{2H3+}	G20	20
		G30, G31	28-30, 37
IRELAND (IE)	II _{2H3+}	G20	20
		G30, G31	28-30, 37
LUXEMBOURG (LU)	II _{2E3B/P}	G20	20
		G30, G31	50
NETHERLANDS (NL)	II _{2L3P}	G25	25
		G31	50
	II _{2L3B/P}	G25	25
		G30, G31	30
NORWAY (NO)	I _{3B/P}	G30, G31	30
PORTUGAL (PT)	II _{2H3+}	G20	20
		G30, G31	28-30, 37
SPAIN (ES)	II _{2H3+}	G20	20
		G30, G31	28-30, 37
	II _{2H3P}	G20	20
		G31	37, 50
SWEDEN (SE)	II _{2H3B/P}	G20	20
		G30, G31	30
UNITED KINGDOM (GB)	II _{2H3+}	G20	20
		G30, G31	28-30, 37

* *H152-2 units are not approved for G30 (Butane) gas.*

The size of the gas line used for installation is very important. If the line is too small, the gas pressure at the burner manifold will be low. This may cause slow recovery and delayed ignition. Frymaster recommends the incoming gas supply line be a minimum of 1½" (38 mm) in diameter. Refer to the chart on the following page for the minimum sizes of connection piping.

Gas Connection Pipe Sizes (Minimum incoming pipe size should be 1 1/2" (38 mm))			
Gas	Single Unit	2 - 3 Units	4 or more units*
Natural	3/4" (19 mm)	1" (25 mm)	1 1/4" (33 mm)
Propane	1/2" (13 mm)	3/4" (19 mm)	1" (25 mm)
Manufactured	1" (25 mm)	1 1/4" (33 mm)	1 1/2" (38 mm)

* For distances of more than 20 feet (6 m) and/or more than 4 fittings or elbows, increase the connection by one pipe size.

Before connecting new pipe to your unit, the pipe must be thoroughly blown out to remove any foreign particles. If these foreign particles get into the burner and controls, they will cause improper and sometimes dangerous operation.

CE Standard
Required airflow for the combustion air supply is 2m³/h per kW.

1. Connect the quick-disconnect hose to the fryer quick-disconnect fitting under the front of the fryer and to the building gas line.

NOTE: Some fryers are configured for a rigid connection to the gas supply line. These units are connected to the gas supply line at the rear of the unit.

When using thread compound, use very small amounts on male threads only. Use a pipe thread compound that is not affected by the chemical action of LP gases (Loctite™ PST56765 Sealant is one such compound). DO NOT apply compound to the first two threads. This will ensure that the burner orifices and control valve do not become clogged.

2. Open the gas supply to the fryer and check all piping, fittings, and gas connections for leaks. A soap solution should be used for this purpose.

⚠ DANGER
Never use matches, candles, or any other ignition source to check for leaks.
If gas odors are detected, shut off the gas supply to the fryer
at the main shut-off valve and contact the local gas company or an authorized
service agency for service.

3. Close the fryer drain valve and fill the frypot with water and boil-out solution to the bottom OIL-LEVEL line at the rear of the frypot. Light the fryer and perform the boil-out procedures that are described in the "Lighting Instructions" and "Boiling Out the Frypot" topics found in Chapter 3 of this manual.

⚠ WARNING

“Dry-firing” your unit will cause damage to the frypot. Always ensure that melted shortening, cooking oil, or water and boil-out solution is in the frypot before firing your unit for any extended period.

4. It is suggested that the burner manifold pressure be checked at this time by the local gas company or an authorized service agent. Refer to “Check Burner Manifold Pressure” on 3.4 of this manual for the proper procedure. The accompanying tables list the burner manifold gas pressures for the various gas types that can be used with this equipment.

CE Standard Burner Manifold Gas Pressures for Fryers Manufactured After April 1999		
Gas	Pressure (mbar)	
	Single Vat	Dual Vat
Natural Gas Lacq (G20) under 20 mbar	7	7
Natural Gas Groningue * (G25) under 25 mbar	10	10
Natural Gas Groningue (G25) under 20 mbar	10	10
Butane (G30) at 28/30 or 50 mbar	17	17
Propane (G31) under 37 or 50 mbar	20	20

* Belgian G25 = 7,0 mbar (single or dual)

CE Standard Burner Manifold Gas Pressures for Fryers Manufactured Through April 1999		
Gas	Pressure (mbar)	
	Single Vat	Dual Vat
Natural Gas Lacq (G20) under 20 mbar	7	6,5
Natural Gas Groningue * (G25) under 25 mbar	10	9
Natural Gas Groningue (G25) under 20 mbar	10	9
Butane (G30) at 28/30 or 50 mbar	17	16,5
Propane (G31) under 37 or 50 mbar	20,2	18,5

* Belgian G25 = 7,0 mbar (single) or 6,5 (dual)

Non-CE Standard Burner Manifold Gas Pressures	
Gas	Pressure
Natural	3" W.C. 0.73 kPa
Propane	8.25" W.C. 2.5 kPa

5. Check the programmed temperature or analog controller thermostat setting. (Refer to Chapter 3, Operating Instructions, for the setpoint programming instructions for your particular controller.)

2.5 Converting to Another Gas Type

Your fryer is configured at the factory for either natural gas or propane (LP) gas. If you desire to switch from one type of gas to another, a gas conversion kit must be installed by a Factory Authorized Service Center technician.

⚠ DANGER

Switching to a different type of gas without installing the proper conversion kit may result in fire or explosion! NEVER attach your fryer to a gas supply for which it is not configured.

H52 Series Fryers manufactured for Non-CE countries use different burners for each type gas. The burners in fryers built for Propane gas have a special gray-colored coating on the burner tiles to enable them to withstand the higher caloric value of the Propane gas. Burners designed for use in Propane units may be used in natural gas applications, but not vice versa.

Non-CE Gas Conversion Kits

Natural Gas to Propane (LP) Gas
Full Vat: Part Number 826-1145
Dual Vat: Part Number 826-1147

Propane (LP) Gas to Natural Gas
Full Vat: Part Number 826-1146
Dual Vat: Part Number 826-1148

Units manufactured for export to CE countries are equipped with “universal” burners that may be used with either natural (G20, G25) gas or Butane (G30) and Propane (G31) gasses.

CE Gas Conversion Kits for Units with Gas Valve 810-1011

G20 or G25 (Natural) to G30 or G31 Gas:
Part Number 826-1196

G30 or G31 to G20 or G25 (Natural) Gas:
Part Number 826-1197

CE GAS CONVERSION INSTRUCTIONS

1. Between G20- and G25-type Natural Gas, adjust the gas pressure at the regulator. (Refer to the CE Standard Burner Manifold Gas Pressure Chart.) Do not change the orifice.
2. Between a 2nd family (G20 or G25) and a 3rd family gas (G30 Butane or G31 Propane):
 - a. Change the orifices.
 - b. Change the gas valve spring (units with valve part number 810-1011 only)
 - c. Adjust the manifold pressure.
3. Remove the rating plate and install a new one. Call your local service agency or KES for a new rating plate.
4. If the destination language changes, replace the labels. Call your local service agency or KES for a label kit. The language of reference will be on the corner of the label.

2.6 Frypot Boil-Out

Before the fryer is first used for cooking product, it should be boiled out to ensure that any residue from the manufacturing process has been eliminated.

In addition, after the fryer has been in use for a period of time, a hard film of caramelized vegetable oil will form on the inside of the frypot. This film should be periodically removed by following the boil-out procedure.

Refer to Fryers Maintenance Requirement Card (MRC) 14A for the boil-out procedure.

CHAPTER 3: SERVICE PROCEDURES, TROUBLESHOOTING AND WIRING DIAGRAMS

3.1 Functional Description

H52 Series fryers contain a welded stainless steel frypot that is directly heated by a high efficiency infrared burner system requiring approximately 43% less energy than conventional burners to cook the same volume.

Self-contained combustion chambers (referred to as “burners”) are fitted into rails attached to the sides of the frypot, one on each side. Each combustion chamber is fitted with special ceramic tiles that are heated by the burning of a forced air/gas mixture. The tiles transfer their heat to the frypot by means of infrared radiation, providing much more constant and uniform heat dispersion over the surface of the frypot than do conventional burners. Because relatively less heat is lost to the atmosphere in the process, compared to “open-burner” designs, less fuel is required to achieve and maintain a given frypot temperature.

In full-vat units, gas flow to both of the burners is regulated by one electromechanical gas valve. In dual-vat units, each burner has its own valve. All fryers in this series are equipped with 24VAC gas valve systems, and all are configured with electronic ignition.

THE ELECTRONIC IGNITION SYSTEM

An ignition module mounted in the component box or “shield” (located behind the control panel) is connected to an ignitor assembly at the burner. The ignition module performs three important functions: it provides an ignition spark, supplies voltage to the gas valve, and proofs the burner flame. The module contains a 4-second time delay circuit and a coil that activates the gas valve. Three designs are in use. The module used in Australian export units resembles an interface board. A closed-box design is used in units built for the U.S. and other export markets. Before mid-2001, fryers (other than Australian) were equipped with two 807-1006 modules. Fryers built after late 2000 to mid-2001 are equipped with two 807-3365 (dual vat) or one 807-3366 (full vat) module. Fryers built between late-2000 and mid-2001 may have either configuration. Australian units continue to use two 807-2971 modules.

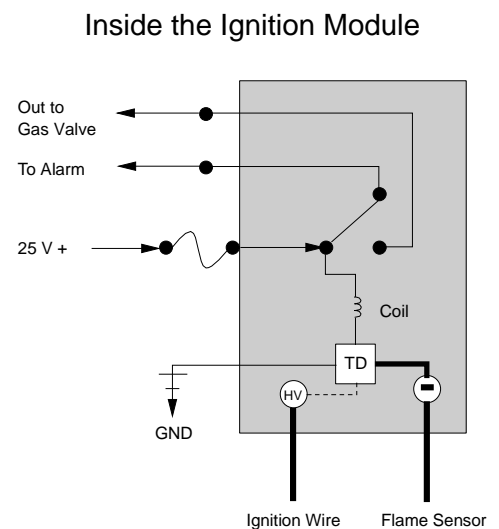

The ignitor assembly consists of a spark plug, an enrichment tube, and a flame sensor.

At start-up, the power switch is placed in the ON position, supplying approximately 12-volts DC to the heat control circuitry in the controller or computer and to one side of the heat relay coils on the interface board. If resistance in the temperature probe indicates the temperature in the frypot is below 180°F (82°C), the current flows through a melt cycle circuit where a timer switch alternately closes for 6 seconds and opens for 24 seconds. If the temperature is 180°F (82°C) or above, the current flows through a heat circuit, bypassing the timer switch. In either case, ground is supplied to the other leg of the heat relay coils, which then close electronic switches in the 24VAC circuit to

provide current to the ignition module. Circuitry in the ignition module sends 24VAC to the gas valve via a normally closed high-limit switch (and, in BIH52 fryers, a normally closed drain safety switch). Simultaneously, the module causes the ignitor to spark for 4 seconds to light the burner. A flame sensor verifies the burner is lit by measuring the flow of microamps through the flame. If the burner does not light (or is extinguished), current to the ignition module is cut, the gas valve closes, and the ignition module “locks-out” until the power switch is turned off and then back on.

A probe monitors the temperature in the frypot. When the programmed setpoint temperature is reached, resistance in the probe causes the heat cycle circuitry in the controller to cut off current flow through the heat relay. This in turn cuts off the 24VAC to the ignition module, causing the gas valve to close.

H52 Series fryers may be equipped with solid-state analog controls, M100B computers, or M2000 computers.

All fryers in this series have an interface board located in the component box located behind the control panel.

INTERFACE BOARDS

The interface board provides a link between the controller/computer and the fryer’s individual components without requiring excessive wiring, and allows the controller to execute commands from one central point. The H52 Series of fryers has been in production since 1983. Consequently, servicers are likely to encounter several different interface board designs. Although the boards differ in appearance, basic functioning and electrical connections are the same from one to another. In late-2000, a new, unfused, ignition module design was introduced. Consequently, an additional fuse was added to the design of interface board 806-3398 to compensate. The new, two-fuse board is P/N 106-0386. With the exception of manufactured gas units, no matter what generation board is in the fryer now, if it becomes necessary to replace the board, either P/N 806-3398 or 106-0386 will be the replacement part installed. If unit being serviced is equipped with *two* P/N 807-1006 or 807-2971 ignition modules, either interface board may be used. If the unit is equipped with *one* P/N 807-3365 or 807-3366 ignition module, interface board 106-0386 should be used. The two boards most likely to be seen (i.e., the two latest designs) are illustrated below.

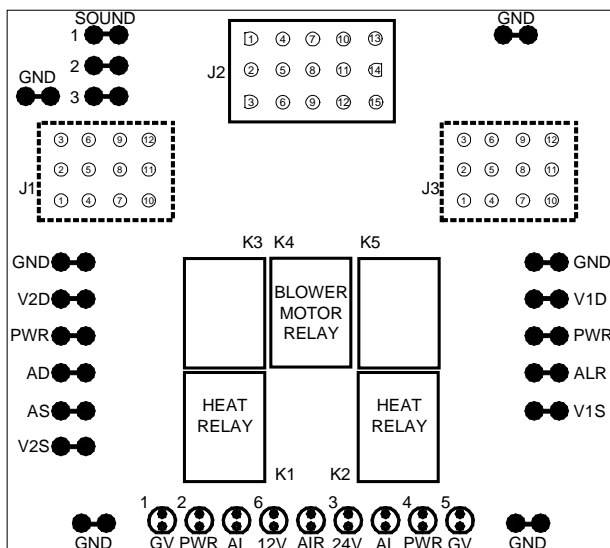

EARLIER DESIGN INTERFACE BOARD P/N 806-3398

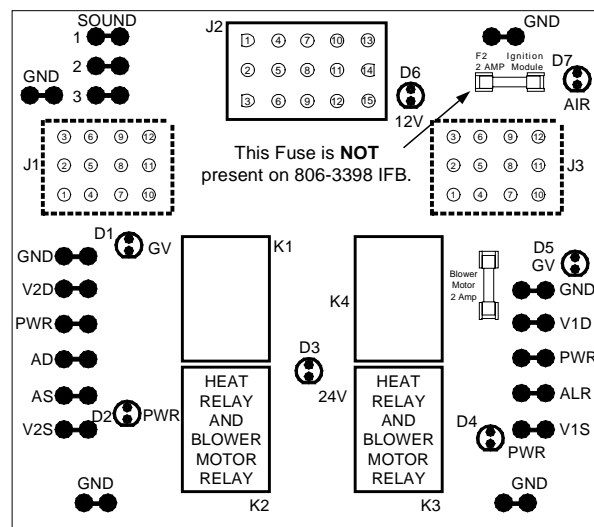

LATER DESIGN INTERFACE BOARDS P/N 806-3398 and 106-0386

FREQUENTLY USED TEST POINTS FOR INTERFACE BOARDS 806-3398 AND 106-0386			
Test	Meter Setting	Pins	Results
12VAC Power to Controller	50VAC Scale	1 and 3 on J3 or J2	12-18
24VAC Power to Right Module	50VAC Scale	8 on J3 and GROUND	22-28
24VAC Power to Left Module	50VAC Scale	8 on J1 and GROUND	22-28
120 VAC Power	250VAC Scale	11 on J3 and GROUND	110-125
120 VAC Power to Blowers	250VAC Scale	12 on J3 and GROUND	110-125
24VAC Power to Right High-Limit	50VAC Scale	9 on J3 and GROUND	22-28
24VAC Power to Left High-Limit	50VAC Scale	9 on J1 and GROUND	22-28
Probe Resistance (Right) *	R x 1000 OHMS	2 and 6 on J3 or 13 and 14 on J2	**
Probe Resistance (Left) *	R x 1000 OHMS	2 and 6 on J1 or 14 and 15 on J2	**
Probe Isolation	R x 1000 OHMS	6 on J1 or J3 and GROUND	***
High-Limit Continuity (Right)	R x 1 OHM	9 on J3 and Wire 13C on Gas Valve	0
High-Limit Continuity (Left)	R x 1 OHM	9 on J1 and Wire 12C on Gas Valve	0
* Disconnect 15-pin harness from controller before testing probe circuit.			
** See Probe Resistance Chart at end of chapter.			
*** 5 mega-Ohms or greater.			

These standard interface boards are also used in a number of fryer types besides the H52 Series. **The information contained in this section applies to H52 Series applications ONLY.**

The earlier design 806-3398 board contains two heat relays (K1 and K2) that switch 24VAC to the ignition and gas valve circuits when the computer/controller heat logic circuit calls for heat. Relay K4 switches 120VAC to the blower motor when either K1 or K2 closes. The relays on this board are soldered on – if one fails, the whole board must be replaced.

The newer design 806-3398 and 106-0386 boards have one or two relays. In this design, K2 and K3 are double-pole-double throw (dpdt) relays that supply 24VAC to the ignition and gas valve circuits, as well as 120VAC to the blower motor. The relays on this board plug into sockets. If a relay fails, that relay can be replaced.

All three interface boards have LEDs to assist in troubleshooting. On the earlier design 806-3398 board, nine LEDs are arranged along the bottom. Later versions of the 806-3398 board, and the 106-0386 board have seven LEDs placed at various locations. The tables below identify the LEDs and their meaning.

EARLIER DESIGN INTERFACE BOARD LED DIAGNOSTIC LIGHTS	
12V	Indicates 12 VAC from transformer
24V	Indicates 24 VAC from transformer
GV	Indicates 24 VAC to gas valve (left or right)
PWR	Indicates 24 VAC to module (left or right)
AL	Indicates module lock-out (left or right)
AIR	CE and Japanese units only: air switch closed

LATER DESIGN INTERFACE BOARD LED DIAGNOSTIC LIGHTS	
1	24 VAC to left gas valve (dual vat only)
2	24 VAC to left ignition module
3	24 VAC from transformer
4	24 VAC to right ignition module
5	24 VAC to gas valve (right valve if dual vat)
6	12 VAC from transformer
7	CE and Japanese units only: air switch closed

INTERFACE BOARD

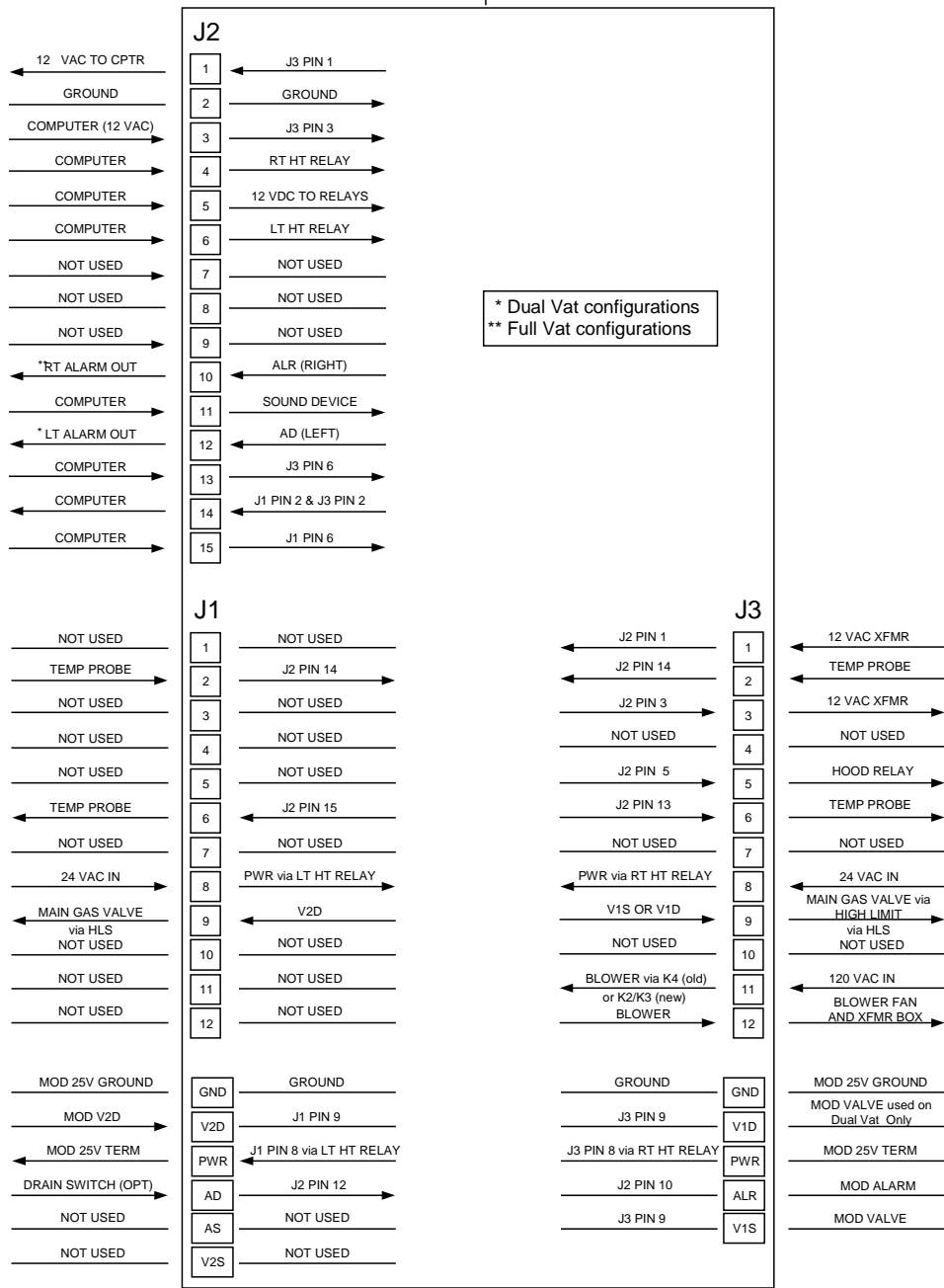

LEFT VAT

FULL OR RIGHT VAT

CURRENT FLOW THROUGH INTERFACE BOARDS 806-3398 AND 106-0386 (H52 APPLICATION)

THERMOSTATS

All fryers in the H52 Series have *temperature probes* located on the front centerline of each the frypot. (Dual vat frypots have a probe in each vat.) In this type thermostat, the probe resistance varies directly with the temperature. That is, as the temperature rises, so does resistance, at a rate of approximately 2 ohms for every 1° F. Circuitry in the controller monitors the probe resistance and controls burner firing when the resistance exceeds or falls below programmed temperatures (set-points). The temperatures are programmed by means of a keypad or knob on the face of the controller.

H52 Series fryers are also equipped with a *high-limit thermostat*. In the event that the fryer fails to properly control the oil temperature, the high-limit thermostat prevents the fryer from overheating to the flash point. The high-limit thermostat acts as a normally closed power switch that opens when exposed to temperatures above 425°F to 450°F (218°C to 232°C). The different types of thermostats have different part numbers for CE and Non-CE configured models, and are not interchangeable.

3.2 Accessing Fryers for Servicing

 **DANGER**

Moving a fryer filled with cooking oil/shortening may cause spilling or splattering of the hot liquid. Follow the draining instructions in Chapter 4 of this manual before attempting to relocate a fryer for servicing.

1. Shut off the gas supply to the unit. Unplug the power cords. Disconnect the unit from the gas supply.
2. Remove any attached restraining devices.
3. Relocate the fryer for service accessibility.
4. After servicing is complete, reconnect the unit to the gas supply, reattach restraining devices, and plug in the electrical cords.

3.3 Cleaning the Gas Valve Vent Tube

NOTE: This procedure is not required for fryers configured for export to CE countries.

1. Set the fryer power switch and the gas valve to the OFF position.
2. Carefully unscrew the vent tube from the gas valve. **NOTE:** The vent tube may be straightened for ease in removal.
3. Pass a piece of ordinary binding wire (.052 inch diameter) through the tube to remove any obstruction.

4. Remove the wire and blow through the tube to ensure it is clear.
5. Reinstall the tube and bend it so that the opening is pointing downward.

3.4 Checking the Burner Manifold Gas Pressure

⚠ DANGER
Frymaster recommends that ONLY qualified service personnel perform this task.

1. **On non-CE fryers**, ensure that the gas valve knob is in the OFF position.

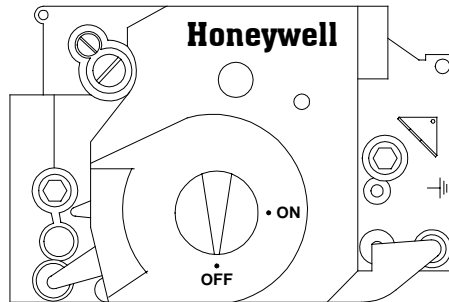

2. Remove the pressure tap plug from the gas valve assembly.

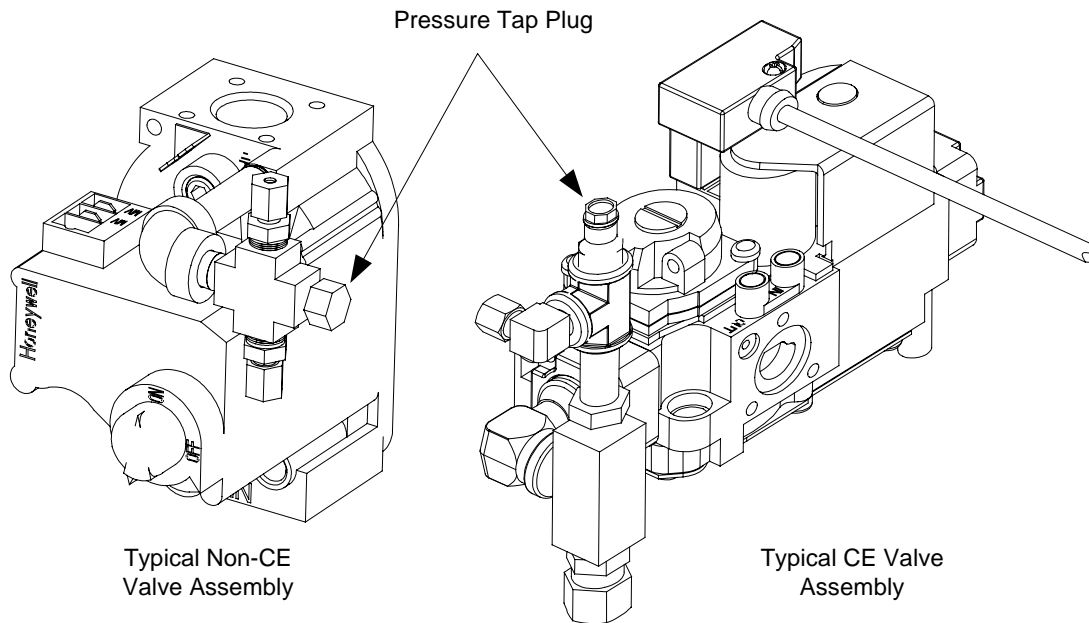

2. Insert the fitting for a gas pressure-measuring device into the pressure tap hole.
3. **On non-CE fryers only**, place the gas valve in the ON position.
4. Place the fryer power switch in the ON position. When the burner has lit and burned steadily for at least one minute, compare the gas pressure reading to the pressure for the corresponding gas in the appropriate table found on the following page.

**CE Standard
Burner Manifold Gas Pressures
for Fryers Manufactured After April 1999**

Gas	Pressure (mbar)	
	Single Vat	Dual Vat
Natural Gas Lacq (G20) at 20 mbar	7	7
Natural Gas Gronique * (G25) at 25 mbar	10	10
Natural Gas Gronique (G25) at 20 mbar	10	10
Butane/Propane (G30) at 28/30 or 50 mbar	17	17
Propane (G31) at 37 or 50 mbar	20	20

* Belgian G25 = 7.0 mbar (single or dual)

**CE Standard
Burner Manifold Gas Pressures
for Fryers Manufactured Through April 1999**

Gas	Pressure (mbar)	
	Single Vat	Dual Vat
Natural Gas Lacq (G20) under 20 mbar	7	6.5
Natural Gas Gronique * (G25) under 25 mbar	10	9
Natural Gas Gronique (G25) under 20 mbar	10	9
Propane (G31) under 37 or 50 mbar	20.2	18.5

* Belgian G25 = 7.0 mbar (single) or 6.5 (dual)

**Non-CE Standard
Burner Manifold Gas Pressures**

Gas	Pressure
Natural	3" W.C. 0.73 kPa
LP	8.25" W.C. 2.5 kPa

- To adjust the burner gas pressure, remove the cap from the gas valve regulator and adjust to the correct pressure.

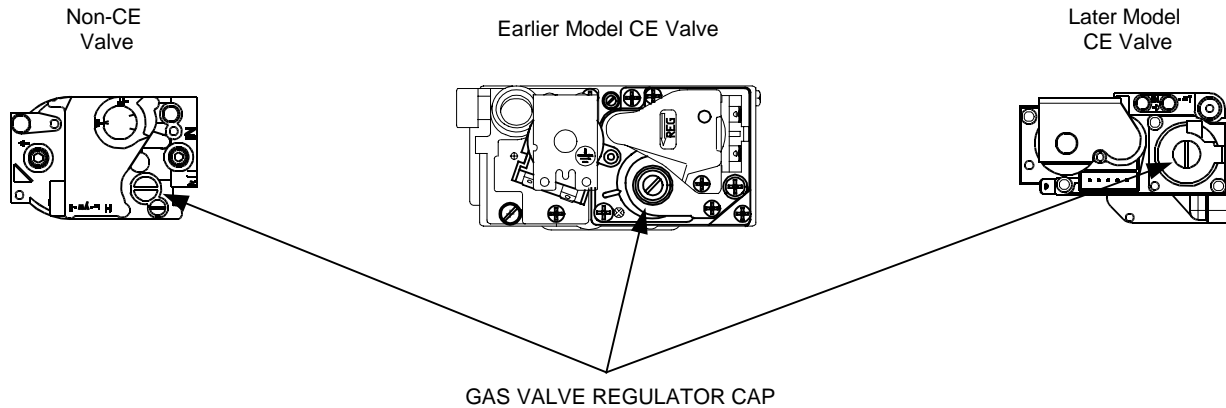

- Place the fryer power switch (and the gas valve in non-CE fryers) in the OFF position. Remove the fitting from the pressure tap hole and reinstall the pressure tap plug.

3.5 Measuring Flame Current

When the burner flame is properly adjusted, it will produce a current between 2.5 μA and 3.5 μA . Flame current is measured by placing a *microamp* (not milliamp) meter in series with the sensing wire on the ignitor. This is accomplished as follows:

- Place the fryer power switch in the OFF position.
- Disconnect the white sensing wire from one of the burner ignitors and connect it to the positive lead of the meter. Connect the negative lead of the meter to the terminal from which the sensing wire was removed.
- Place the fryer power switch in the ON position to light the burners. After the frypot temperature reaches 200°F (93°C), wait at least one minute before checking the reading. **NOTE:** The closer the unit is to normal operating temperature, the more accurate the reading will be.

3.6 Replacing Fryer Components

3.6.1 Replacing the Controller or the Controller Wiring Harness

- Disconnect the fryer from the electrical supply.
- Remove the two screws in the upper corners of the control panel and swing the panel open from the top, allowing it to rest on its hinge tabs.
- Disconnect the wiring harness from the back of the controller and, if replacing the harness, disconnect it from the interface board.
- Disconnect the ground wire from the controller, and remove the controller by lifting it from the hinge slots in the control panel frame.
- Reverse the procedure to install a new controller or wiring harness.

3.6.2 Replacing the Temperature Probe or High-Limit Thermostat

1. Disconnect the fryer from the electrical supply.
2. Drain cooking oil below the level of the probe or thermostat.
3. Remove the screws from the upper corners of the control panel and swing the panel open from the top, allowing it to rest on its hinge tabs.
4. Unplug the controller wiring harness from the back of the controller.
5. Disconnect the ground wire from the controller, and remove the controller by lifting it from the hinge slots in the control panel frame.
6. Remove the screws securing the topcap to the fryer and lift the topcap up and off the fryer.
7. Disconnect the ignition cables from the ignitors by grasping the boots and gently pulling toward you.
8. Remove the screws securing the control panel frame in place and remove the frame.
9. Remove the component box mounting screws and rotate the top of the component box out of the cabinet. Carefully pull it out far enough to disconnect the wiring harness plug(s) from the back of the box. Remove the box and set it aside.
10. On CE fryers with a blower shield assembly installed, remove the screws securing the shield in place and remove it from the cabinet.
11. Make a note of the location of the existing wires. Using a pin-pusher, disconnect the temperature probe wires (or high-limit thermostat wires) from the connector plug.
12. Unscrew and remove the temperature probe (or high limit thermostat) from the frypot.
13. Apply Loctite[®] PST56765 pipe thread sealant or equivalent to the replacement part threads.
14. Screw the replacement part into the frypot.
15. Connect the wires from the new component to the connector plug, referring to the note made in step 11.
16. Reverse steps 1 through 10 to complete the procedure.

3.6.3 Replacing the Interface Board

1. Remove the component box per steps 1 through 9 of Section 3.6.2.
2. Unplug the controller wiring harness from the interface board.
3. Disconnect the wires attached to the interface board, marking or making a note of the wires and terminals to facilitate reconnection.
4. Remove the nuts at each corner of the interface board and pull it from the studs.
5. Reverse the procedure to install the replacement board, being sure to reinstall the spacers behind the interface board.

3.6.4 Replacing an Ignition Module

1. Disconnect the fryer from the electrical supply.
2. Remove the screws from the upper corners of the control panel and swing the panel open from the top, allowing it to rest on its hinge tabs.
3. Disconnect the wires from the ignition module, marking or making a note of the wires and terminals to facilitate reconnection.
4. Remove the four ignition module screws and pull the module from the component box.
5. Reverse the procedure to install the replacement module.

3.6.5 Replacing an Ignitor Assembly



Drain the frypot or remove the handle from the drain valve before proceeding further.

1. Disconnect the fryer from the electrical supply.
2. Disconnect the ignition cable from the ignitor by grasping the boot and gently pulling toward you.
3. Remove the two sheet metal screws securing the ignitor to the mounting plate and pull the ignitor from the fryer.
4. Reverse the procedure to install the replacement ignitor.

3.6.6 Cleaning or Replacing a Combustion Air Blower

A sheet metal shield or shield assembly prevents inadvertent access to the blower assembly. The specific design varies depending upon the particular configuration of the fryer and the country for which manufactured, but in all cases, the shield is attached to the cabinet framing by sheet metal screws. Remove the screws that secure the shield or shield assembly to the cabinet framing and pull the shield out of the fryer to expose the combustion air blower assembly.

1. Disconnect the blower wiring harness and remove the blower assembly mounting nuts.

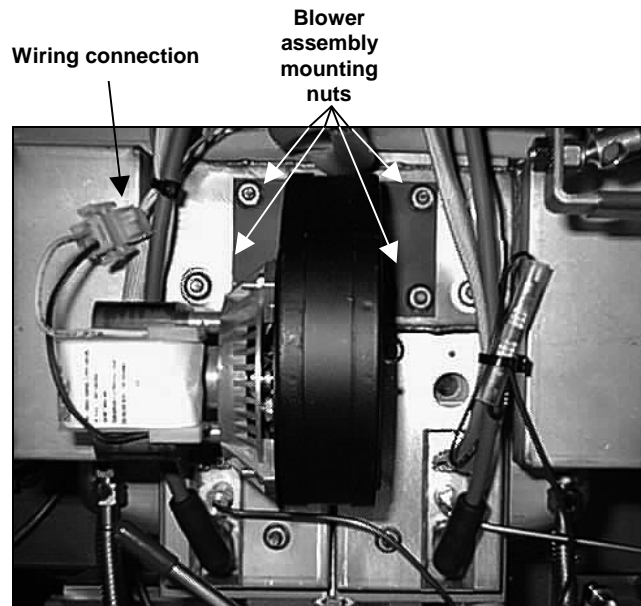

2. Remove the three fasteners that secure the blower motor assembly to the blower housing, and separate the two components.

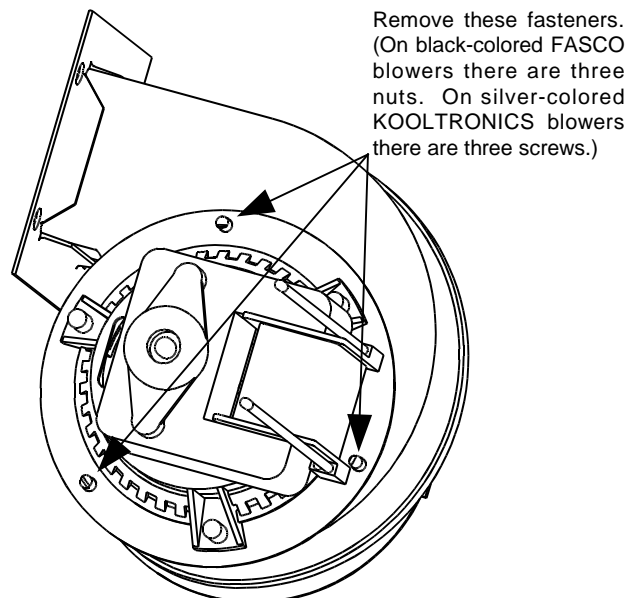

3. Wrap the motor with plastic wrap to prevent water from entering it. Spray degreaser or detergent on the blower wheel and the blower housing. Allow it to soak for five minutes. Rinse the wheel and housing with hot tap water, then dry with a clean cloth.

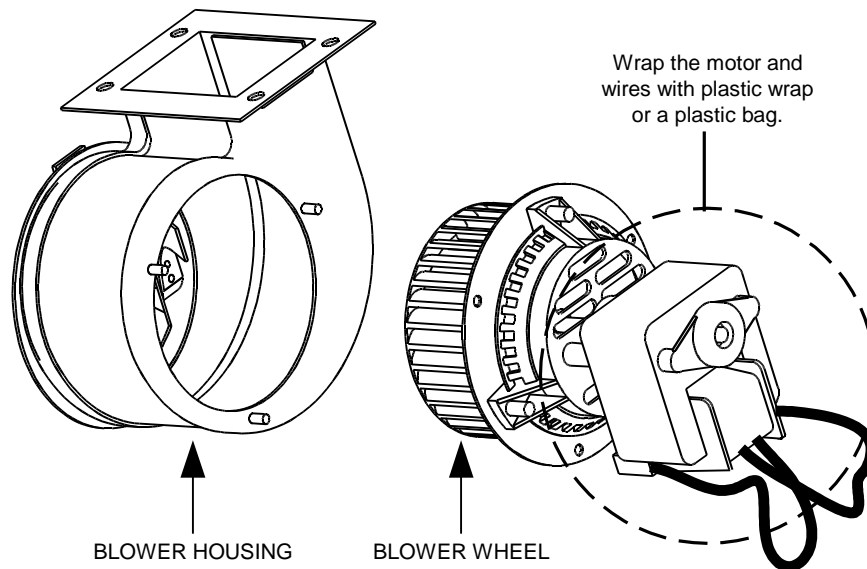

4. Remove the plastic wrap from the blower motor assembly. Reassemble the blower motor assembly and blower housing. Reinstall the blower assembly in the fryer.
5. Reinstall the blower shield or shield assembly.
6. Light the fryer in accordance with the procedure described in Chapter 3, Section 3.1.
7. After the burners have been lit for at least 90 seconds, observe the flames through the burner viewing ports located on each side of the combustion air blower.

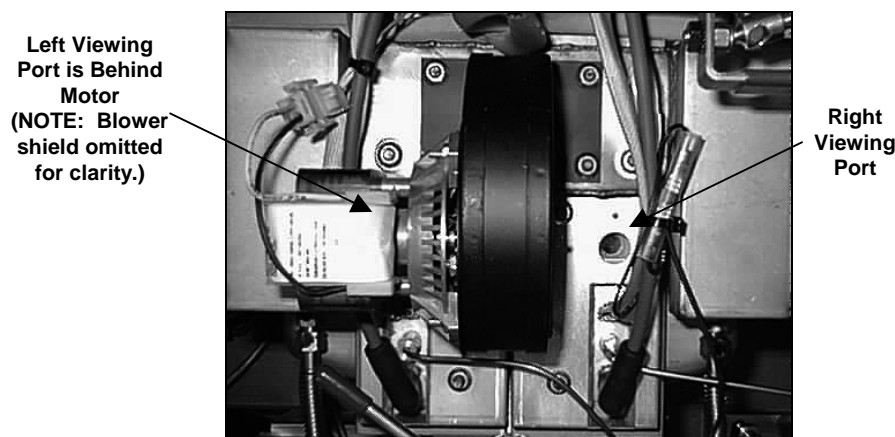

The air/gas mixture is properly adjusted when the burner manifold pressure is in accordance with the applicable table on page 3-7 and the burners display a bright orange-red glow. If a blue flame is observed, or if there are dark spots on a burner face, the air/gas mixture requires adjustment.

Adjusting Air/Gas Mixture Non-CE Units and CE Units Built After April 1999

On the side of the blower housing opposite the motor is a plate with one or two locking nuts. Loosen the nut(s) enough to allow the plate to be moved, then adjust the position of the plate to open or close the air intake opening until a bright orange-red glow is obtained. Carefully hold the plate in position and tighten the locking nut(s).

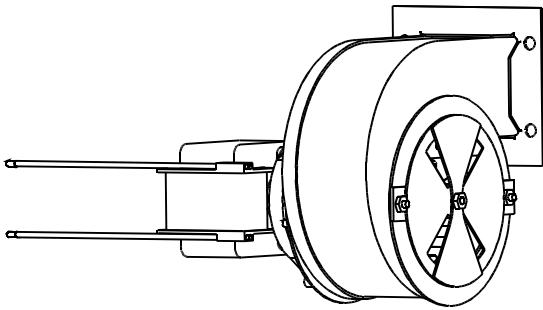

TYPICAL NON-CE BLOWER ASSEMBLY

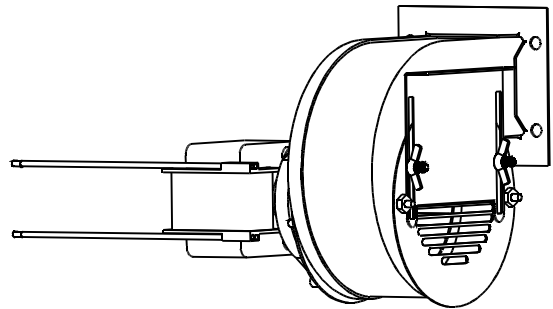

TYPICAL CE BLOWER ASSEMBLY
ON UNITS BUILT AFTER APRIL 1999

Adjusting Air/Gas Mixture CE Units Built Through April 1999

CE units built through April 1999 are equipped with a shield assembly in front of the blowers. An air shutter plate on the face of the shield assembly regulates the amount of airflow to the blower intake. To adjust the shutter plate, loosen the locking screws and slide the shutter to the left or right as necessary to obtain a bright orange-red glow. Carefully hold the shutter plate in position and tighten the locking screws.

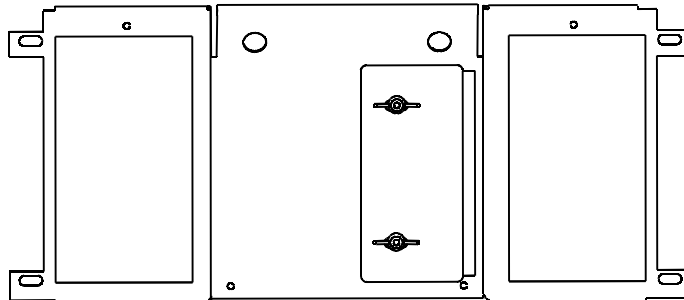

TYPICAL CE BLOWER SHIELD ASSEMBLY
ON UNITS BUILT THROUGH APRIL 1999

3.6.7 Replacing a Gas Valve



DANGER

Drain the frypot or remove the handle from the drain valve before proceeding further.

1. Disconnect fryer from electrical and gas supplies.
2. Disconnect the wires from the gas valve terminal block, marking each wire to facilitate reconnection.
3. Remove the vent tube and the enrichment tube fitting from the valve.
4. Disconnect the flexible gas line(s).
5. Carefully unscrew the valve from the manifold. NOTE: Some models may have the valve attached to the manifold by means of a pipe union. In such cases, remove the valve by uncoupling the union.
6. Remove all fittings from the old gas valve and install them on the replacement valve, using Loctite® PST56765 or equivalent pipe thread sealant.
7. Apply Loctite® PST 56765 or equivalent pipe thread sealant to the threads of the manifold (or the union). Reverse steps 1-5 to install the replacement gas valve.

3.6.8 Replacing a Burner Assembly



DANGER

Drain the frypot or remove the handle from the drain valve before proceeding further.

1. Disconnect the unit from the electrical and gas supplies.
2. Remove the combustion air blower per the procedure found in Section 3.6.6.
3. Remove the four nuts from the air plenum assembly and pull the assembly straight out toward you until it clears the burner tubes.
NOTE: On a dual vat fryer, it will be necessary to remove the drain valve handles before the plenum can be removed.
4. Disconnect the ignition cables from the ignitors by grasping their boots and pulling toward you.
5. Disconnect the gas lines and enrichment tubes from the burner orifices and ignitor assemblies.
6. Remove the four ¼” (6mm) nuts securing the outer front covers to the frypot assembly.
7. Remove the sheet metal screws at the top of the outer front covers and pull the covers straight out toward you until clear of the mounting studs.

8. Remove the washers and tubular spacers from the mounting studs, then pull the inner covers straight out toward you until clear of the mounting studs.
9. Grasp the burner firmly and pull it toward you until it clears the burner channels, taking care not to damage the ceramic tiles in the process.
10. Clean all debris from the burner channels and combustion area.
11. Inspect the upper and lower burner rails for cracked or burned-out welds.
 - a. If the welds in the lower rail are cracked or burned out, the frypot must be replaced. Refer to Section 3.6.9 for procedure.
 - b. If the welds in the upper rail are cracked or burned out, the upper rail must be replaced. Refer to Section 3.6.10 for procedure.
12. Place a new insulating strip along the top, rear, and bottom edge of the burner and carefully slide it straight into the rails.

NOTE: Use P/N 826-0931 for full vat frypots and P/N 826-0932 for dual vat frypots.

13. Reverse steps 1 through 9 to reassemble the components.
14. Fill the frypot with oil. Turn the fryer on, turn off or bypass the melt cycle, and operate the unit for at least 10 minutes.
15. Visually examine the burner flame. The color and intensity on both sides should be the same.
16. Use an inspection mirror to check for leaks in areas that cannot be directly observed.
17. If a leak is detected, tighten all the lower insulation retainer nuts, allow the frypot to run for five additional minutes, and repeat steps 15 and 16.
18. If the leak persists, use a rubber hammer and a small block of wood to tap the corners of the lower combustion chamber insulation retainers. Repeat steps 15 through 17. **Repeat this step until no leakage is detected.**

3.6.9 Replacing the Frypot

1. Drain cooking oil/shortening from the frypot.
2. Remove all accessories, e.g., frypot covers, basket lift arms, etc. from the fryer.
4. Disconnect the fryer from gas and electrical supplies.
5. Remove the screws from the topcap above the control panel and lift it up and off the fryer(s).

6. Remove the screws from the upper left and right corners of the control panel. Open the panel, disconnect the controller wiring harness and ground wire. Remove the controller from the fryer.
 7. Disconnect the ignition wires from the ignitor plugs by grasping their boots and pulling toward you.
 8. Remove the screws securing the component box to the frame, and then rotate the top of the box forward and out of the fryer enough to disconnect the wiring harness connector plug(s) on the rear of the box. Set the component box aside.
 9. Using a pin pusher, remove the temperature probe and high-limit thermostat wires from the plug(s), marking each wire to facilitate re-assembly.
 10. On BIH52 units, remove the cover from the safety drain switch, disconnect the wires from the switch, and pull them out of the switch box.
 11. On BIH52 units, remove the section(s) of square drain from the drain valve(s) of the frypot to be removed.
 12. Disconnect the gas lines and enrichment tubes from the burner orifices and ignitor assemblies.
 13. Remove the frypot hold down bracket.
 14. Remove the screws from the flue cap sides and back and lift it clear of the fryer(s).
 15. On BIH52 units, disconnect the oil return line(s) from the frypot to be removed.
 16. Carefully lift the frypot from the fryer cabinet.
 17. Remove the drain valve(s), temperature probe(s), high-limit thermostat(s), and ignitor assemblies. Inspect each of these components carefully and install them in the replacement frypot if they are in serviceable condition. Use Loctite[®] PST56765 sealant or equivalent on component threads.
- NOTE:** Some servicers, based upon their experience, recommend that probes and thermostats be replaced whenever a frypot is replaced, but this remains the customer's decision.
18. Reverse steps 1-16 to reassemble fryer.
 19. Perform steps 14 through 18 of Section 3.6.8 to ensure that there are no leaks in the burner insulation.

 **CAUTION**

Before installing the temperature probe, high-limit thermostat, and drain valve on the replacement frypot, clean their threads and apply Loctite[®] PST56765 thread sealant or equivalent.

3.6.10 Replacing Frypot Insulation and/or Upper Burner Rails

NOTE: Replacing the burner rails requires completely tearing down the frypot and installing new frypot insulation. Refer to the frypot exploded view on page 3-18 for component identification.

1. Remove the frypot per Section 3.6.9.
2. Remove the burner assemblies (1).
3. Remove insulation retainers and blanket insulation (2).
4. Remove the upper oil zone insulation bracket and upper oil zone insulation (3).
5. Remove the plenum (4).
6. Remove the front lower combustion chamber insulation retainer and insulation (5), and the front lower combustion chamber inner insulation retainer and insulation (6).

NOTE: Full vat units have two-piece insulation retainer and insulation components. Dual vat units have one-piece components.

7. Remove the upper combustion chamber insulation retainer and insulation (7).
8. Remove the inner upper combustion chamber insulation retainer and insulation (8).
9. Remove the rear lower combustion chamber retainers, back, and insulation (9).

NOTE: Full vat units have two-piece backs and four retainers. Dual vat units have one-piece backs and two retainers.

10. Remove the flue assembly (10).
11. Remove the upper burner rails (11).

NOTE: For the following steps, refer to the frypot exploded view on page 3-19 for component identification.

12. Remove any residual insulation, sealant, and/or oil from the exterior of the frypot.
13. Place the “L” shaped pieces of combustion chamber insulation (1) in the front and rear corners of both upper rail-retaining slots.
14. Use a small amount of furnace or muffler repair cement to seal the gaps at each end of both lower rails. (See inset, page 3-19.)

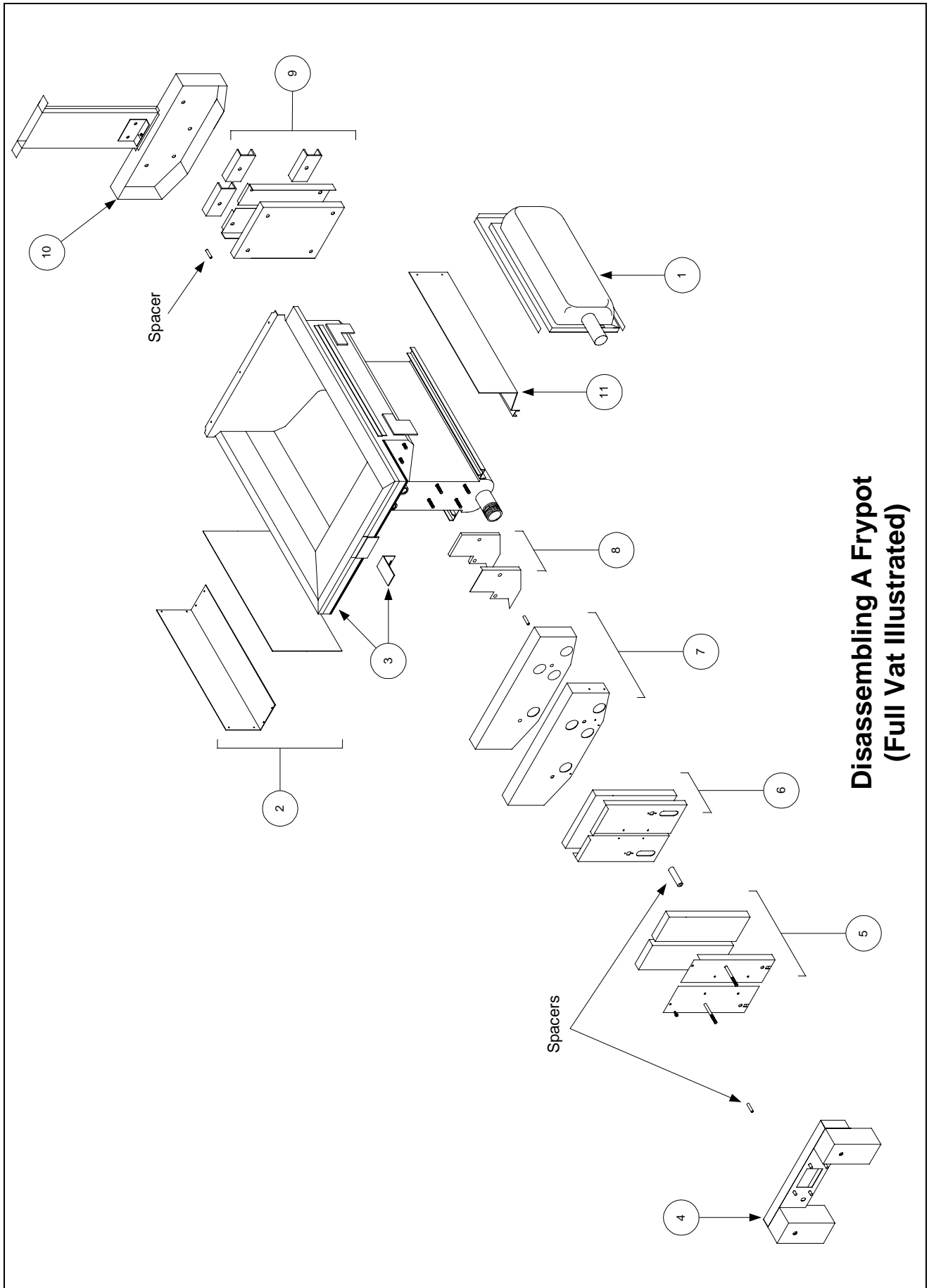

**Disassembling A Frypot
 (Full Vat Illustrated)**

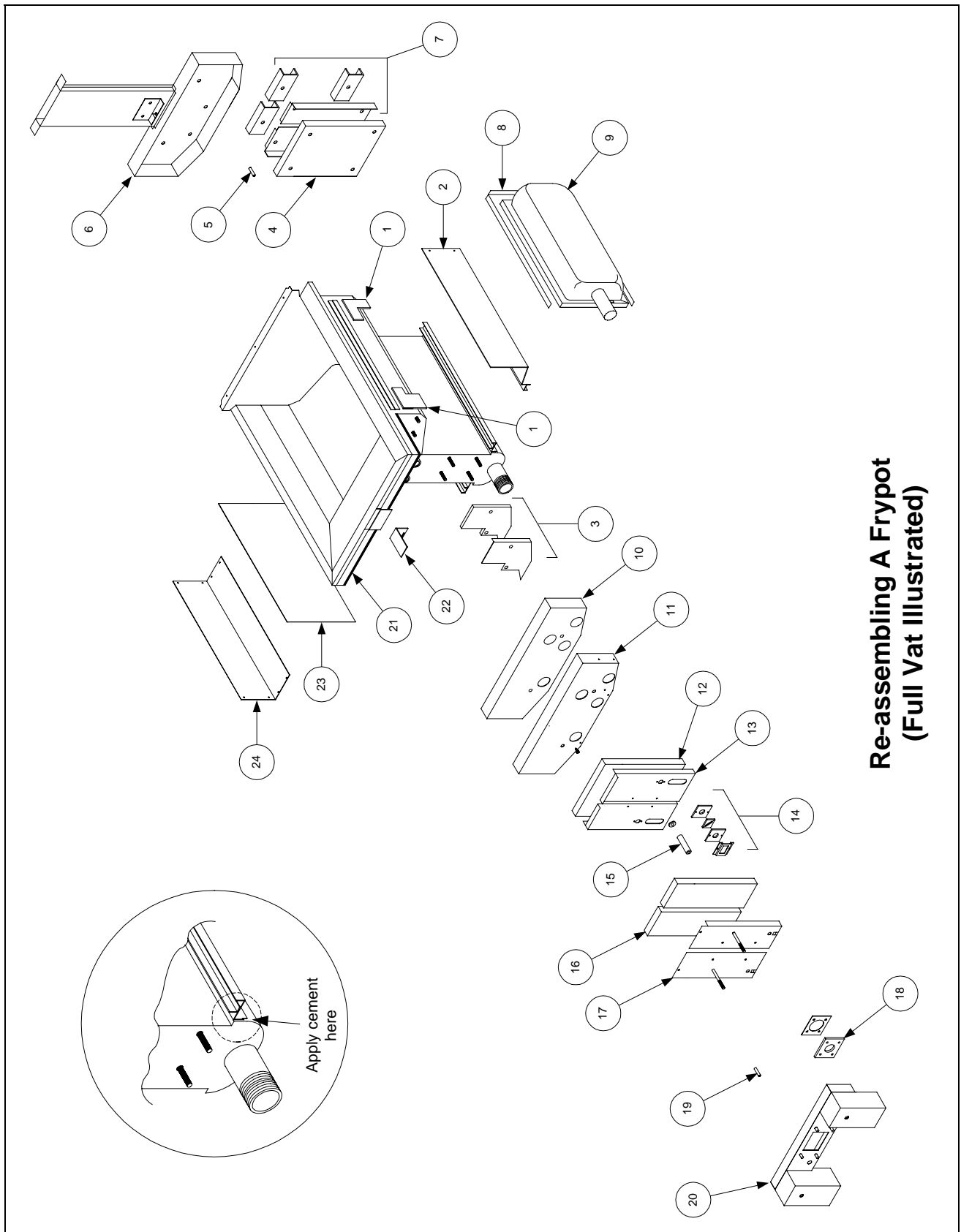

**Re-assembling A Frypot
(Full Vat Illustrated)**

15. Install the upper burner rails (2) with the heat deflectors slanting toward the rear of the frypot. The rails will cover the “L” shaped pieces of combustion chamber insulation previously installed.

16. Place the upper inner combustion chamber insulation and insulation retainers (3) on the top two studs on each side of the front of the frypot and secure with ¼-20 washer-nuts. (It is normal for the retainers to slice off the overhanging insulation.)
17. Place the lower rear combustion chamber insulation (4) on the lower four studs at the rear of the frypot.
18. Place one 1.625-inch tubular spacer (5) on each of the flue assembly (upper) studs at the rear of the frypot.

NOTE: There are three different sizes of spacers. Verify the size to ensure the correct spacers are installed.

19. Press the flue assembly (6) over the burner rails. It may be necessary to use a rubber mallet or screwdriver to align the components. Use four ¼-20 washer nuts to secure the flue assembly. **Do not tighten the retainer nuts at this point. They should be finger-tight only.**

NOTE: The flue edge will cover one to two inches of the lower insulation.

20. Install the lower rear combustion chamber back(s) and retainer(s) (7) with the flanged edge(s) against the flue. Secure with ¼-20 washer nuts.

NOTE: Full vat units have two-piece backs and four retainers. Dual vat units come with one-piece backs and only two retainers.

21. Insert the burners (9) into the rails to ensure the rail spacing and alignment are correct. The burner should slide freely into and out of the rails. The upper rail can be bent slightly to increase or decrease tension on the burner, and the edges of the slot can be closed or opened slightly to best fit the burner frame.

22. Carefully wrap a strip of burner insulation (8) tightly around the rear and sides of the burner frame (9), with the glass-tape side of the strip on the outside. **Do not use duct tape or adhesive to secure the strip to the burner frame.**

23. Align the burner to the burner rails while maintaining tension on the insulation strip. Insert the burner at a slight angle and begin pushing the burner slowly into the rails until it contacts the rear combustion chamber. The fit should be snug, but not excessively tight.

24. Verify that the burners are flush with the front edge of the burner rails. Remove the excess burner insulation by cutting with a knife or diagonal pliers. **Do not try to tear the insulation!**

25. Insert the upper front insulation (10) into its retainer (11), making sure that the holes in each piece are aligned with one another. Install the assembly with the insulation side toward the frypot and secure with ¼-20 washer-nuts. **Do not over tighten.**

26. Place a washer on each of the four lower studs on the front of the frypot. Install the lower inner front insulation (12) with the rectangular openings toward the drain valve nipple. Install the lower inner front insulation retainer(s) (13).

NOTE: Full vat units have a two-piece insulation retainer. Dual vat units have a one-piece retainer.

27. If necessary, replace the sight-glasses and insulation (14).

28. Place one washer and one 1.888-inch spacer (15) on each stud.

NOTE: There are three different sizes of spacers. Verify the size to ensure the correct spacers are installed.

29. Insert the front lower insulation (16) into the front lower insulation retainer(s) (17) and install assembly on frypot. Secure with ¼-20 washer-nuts. If frypot uses two retainers, connect them together with two ¼” self-tapping screws.

NOTE: Full vat units have a two-piece insulation retainer and two pieces of insulation. Dual vat units have one-piece components.

30. Return to the rear of the frypot and fully tighten all washer-nuts.

31. Remove and replace the plenum gaskets (18).

32. Place a 0.938-inch spacer (19) on the plenum-mounting studs, and mount the plenum (20). Ensure the gaskets are clear of the burner tubes by pulling the plenum back slightly. Place a washer on each stud and secure plenum with ¼-20 locknuts.

33. Install the upper oil-zone insulation (21) by pressing it under the upper combustion chamber metalwork. Secure the insulation with the bracket (22) and ¼” self-tapping screws.

34. Install the upper burner rail blanket insulation (23). Position any excess insulation toward the top of the frypot. Avoid overhang past the bottom of the upper burner rail. Overhang in this area will make future burner replacement more difficult.

35. Cover the insulation with the insulation retainer (24), and secure with ¼” self-tapping screws.

36. Reinstall probes, drain valves, high-limit thermostats and other pipefittings using Loctite® PST56765 sealant or equivalent on their threads.

3.7 Troubleshooting and Problem Isolation

Because it is not feasible to attempt to include in this manual every conceivable problem or trouble condition that might be encountered, this section is intended to provide technicians with a general knowledge of the broad problem categories associated with this equipment, and the probable causes of each. With this knowledge, the technician should be able to isolate and correct any problem encountered.

Problems you are likely to encounter can be grouped into six broad categories:

1. Ignition failures
2. Improper burner functioning

3. Improper temperature control
4. Computer-related problems
5. Filtration problems
6. Leakage problems

The probable causes of each category are discussed in the following sections. A series of Troubleshooting Guides (decision trees) is also included at the end of the chapter to assist in identifying some of the more common problems.

3.7.1 Ignition Failures

Ignition failure occurs when the ignition module fails to sense a flame within the 4-second time delay period and locks out. When this happens, the module sends 24VAC through the interface board alarm circuit to the controller/computer.

Analog controllers indicate ignition failure by illuminating the heat light and trouble light simultaneously. M100B and M2000 computers flash “ignition failure” in the display window on the side that failed (in full-vat units, it will flash in the right window only).

The three primary reasons for ignition failure, listed in order of probability, are:

1. Problems related to the gas and/or electrical power supplies
2. Problems related to the electronic circuits
3. Problems related to the gas valve.

PROBLEMS RELATED TO THE GAS AND/OR ELECTRICAL POWER SUPPLIES

The main indicators of this are that an entire battery of fryers fails to light and/or there are no indicator lights illuminated on the fryer experiencing ignition failure. Verify that the quick disconnect fitting is properly connected, the fryer is plugged in, the main gas supply valve is open, and the circuit breaker for the fryer electrical supply is not tripped.

PROBLEMS RELATED TO THE ELECTRONIC CIRCUITS

If gas and electrical power are being supplied to the fryer, the next most likely cause of ignition failure is a problem in the 24VAC circuit. If the fryer is equipped with a built-in filtration system (BIH52 models), first verify that the drain valve is fully closed. (The valve is attached to a microswitch that must be closed for power to reach the gas valve. Often, although the valve handle appears to be in the closed position, the microswitch is still open.) If the valve is fully closed, or the fryer does not have a built-in filtration system, refer to the troubleshooting guides **TROUBLESHOOTING THE 24VAC CIRCUIT**.

Some typical causes of ignition failure in this category include a defective sensing wire in the ignitor assembly, a defective module, a defective ignition wire, and a defective ignitor.

Occasionally you may encounter an ignition failure situation in which all components appear to be serviceable and the microamp reading is within specification, but the unit nevertheless goes into ignition failure during operation. The probable cause in this case is an intermittent failure of an ignition module. When the unit is opened up for troubleshooting, the module cools down enough to

operate correctly, but when the unit is again closed up and placed back into service the module heats up and fails.

PROBLEMS RELATED TO THE GAS VALVE

If the problem is not in the 24VAC circuit, it is most likely in the gas valve itself, but before replacing the gas valve refer to **TROUBLE SHOOTING THE GAS VALVE**.

3.7.2 Improper Burner Functioning

With problems in this category, the burner ignites but exhibits abnormal characteristics such as “popping,” dark spots on the burner ceramics, fluctuating flame intensity, and flames shooting out of the flue.

“*Popping*” indicates delayed ignition. In this condition, the main gas valve is opening but the burner is not immediately lighting. When ignition does take place, the excess gas “explodes” into flame, rather than smoothly igniting.

The primary causes of popping are:

- Incorrect or fluctuating gas pressure
- A defective or incorrectly adjusted combustion air blower
- Inadequate make-up air
- Heat damage to the controller or ignition module
- A cracked ignitor or broken ignition wire
- A defective ignition module
- Cracked burner tile (this typically causes a very loud pop).

If popping occurs only during peak operating hours, the problem may be incorrect or fluctuating gas pressure. Verify that the incoming gas pressure (pressure to the gas valve) is in accordance with the appropriate CE or Non-CE Standard found in Section 2.3 of this manual, and that the pressure remains constant throughout all hours of usage. Refer to page 2-6 for the procedure for checking the pressure of gas supplied to the burner.

If popping is consistent during all hours of operation, the most likely cause is an insufficient air supply. Check for “negative pressure” conditions in the kitchen area. If air is flowing into the kitchen area, this indicates that more air is being exhausted than is being replenished and the burners may be starved for air.

If the fryer’s gas and air supplies are okay, the problem is most likely with one of the electrical components. Examine the ignition module and controller for signs of melting/distortion and/or discoloration due to excessive heat build-up in the fryer. (This condition usually indicates improper flue performance.) A melted or distorted ignition module is automatically suspect and should be replaced, but unless the condition causing excessive heat is corrected, the problem is likely to recur.

Verify that the ignition wire is tightly connected at both ends and free of obvious signs of damage. Again, if damage is due to excessive heat in the fryer, that problem must also be corrected.

Check for proper operation by disconnecting the wire from the ignitor (spark plug), inserting the tip of a screw driver into the terminal, and holding it near the frame of the fryer as the power switch is placed in the ON position. A strong, blue spark should be generated for at least 4 seconds.

 **DANGER**

MAKE SURE YOU ARE HOLDING THE INSULATED HANDLE OF THE SCREWDRIVER AND NOT THE BLADE. THE SPARKING CHARGE IS APPROXIMATELY 25,000 VOLTS.

Examine the ignitor (spark plug) for any signs of cracking. A cracked ignitor must be replaced. If all other causes have been ruled out, examine the burner tiles for any signs of cracking. If found, the burner must be replaced.

Fluctuating flame intensity is normally caused by either improper or fluctuating incoming gas pressure, but may also be the result of variations in the kitchen atmosphere. Verify incoming gas pressure in the same way as for “popping,” discussed in the preceding paragraphs. Variations in the kitchen atmosphere are usually caused by air conditioning and/or ventilation units starting and stopping during the day. As they start and stop, the pressure in the kitchen may change from positive or neutral to negative, or vice versa. They may also cause changes in airflow patterns that may affect flame intensity.

Dark spots on the burner tiles are the result of an improper air/gas mixture. Adjust the combustion air blower to reduce the amount of air in the mixture to correct this problem.

Flames shooting out of the flue are usually an indication of negative pressure in the kitchen. Air is being sucked out of the burner enclosure and the flames are literally following the air. If negative pressure is not the cause, check for high burner manifold gas pressure in accordance with the procedures on page 2-6.

An *excessively noisy burner*, especially with *flames visible above the flue opening*, may indicate that the gas pressure is too high, or it may be that, on non-CE units, the gas valve vent tube is blocked. If the incoming gas pressure is correct and the vent tube on non-CE units is unobstructed, the gas valve regulator is probably defective.

Occasionally a burner may apparently be operating correctly, but nevertheless the fryer has a *slow recovery rate* (the length of time required for the fryer to increase the oil temperature from 270°F to 320°F (133°C to 160°C)). The primary causes of this are an over-filled vat, a dirty or out-of-adjustment combustion air blower, low burner manifold pressure, and/or damaged burner tiles. Adding oil to the frypot during the recovery process will also cause a slow recovery rate. If these causes are ruled out, the probable cause is a misadjusted gas valve regulator. Refer to page 2-6 for the procedure for checking the pressure of gas supplied to the burner.

3.7.3 Improper Temperature Control

Temperature control, including the melt cycle, is a function of several interrelated components, each of which must operate correctly. The principle component is the temperature probe. Other components include the interface board, the controller itself, and the ignition module.

Improper temperature control problems can be categorized into melt cycle problems and failure to control at setpoint problems.

MELT CYCLE PROBLEMS

The melt cycle is automatically initiated by the controller (Analog, M100B, or M2000) when the controller is first turned on. The unit should remain in the melt cycle until the oil in the frypot reaches 180°F (82°C). (Do not confuse the melt cycle with the *LOW TEMP* warning. This warning will be displayed when the M100B or M2000 computer senses that the oil in the frypot is more than 45°F (25°C) below the setpoint.)

Problems may be with the controller itself, the temperature probe, or a malfunctioning heat relay on the interface board.

FAILURE TO CONTROL AT SETPOINT

Problems in this category may be with the temperature probe, the interface board, or the controller.



3.7.4 Recovery Time or “Rate Of Rise” and the M100B “Rec Lock” Condition

Recovery time or “rate of rise” is a method of measuring a fryer’s performance. Put simply, it is the time required for the cooking oil temperature to rise from 270°F to 320°F (133°C to 160°C). This range is used as a standard since ambient kitchen temperatures can effect the test if lower ranges are used.

The M100B computer performs the recovery test when the fryer is first turned on and anytime thereafter when the temperature of the oil drops below 250°F (121°C), such as when cold cooking oil is added to the frypot. If the fryer takes longer than 2 minutes and 35 seconds to recover, the display will show *REC LOCK* and the computer will lock out.

The currently recorded recovery time can be viewed anytime the temperature of the cooking oil is above 270°F (133°C) by pressing the recovery time recall switch .

If REC LOCK occurs three or more times within a week, verify that oil is not being added when the fryer is heating (that is, while a heat mode indicator  is illuminated). If oil is not being added while the fryer is heating, there is a problem with the fryer.

To clear the *REC LOCK* condition, turn the computer off by pressing the *right*  switch. Enter the programming mode by pressing and releasing the *left* ①, ②, and  switches simultaneously. The computer will display its model number and then *FR FRIES YES*. Press the  switch. The computer will display *LOCK CLEARED*.

3.7.5 Filtration Problems

BIH52 units are equipped with FootPrint III built-in filtration systems. The majority of filtration problems arise from operator error. One of the most common errors is placing the filter paper on the bottom of the filter pan rather than over the filter screen.

Whenever the complaint is “the pump is running, but no oil is being filtered,” check the installation of the filter paper, including that the correct size is being used. While you are checking the filter paper, verify that the O-ring on the bottom of the filter pan is present and in good condition. A missing or worn O-ring will allow the pump to suck air and decrease its efficiency.

If the pump motor overheats, its thermal overload will trip and the motor will not start until it is reset. If the pump motor does not start, press the red reset switch located on the rear of the motor. If the pump then starts, something caused the motor to overheat. It may just be that several frypots were being filtered one after the other and the pump got hot. Letting the pump cool down for at least a half-hour is all that is required in this case. More often, the pump overheated for one of the following reasons:

- Shortening was solidified in the pan or filter lines.
- The operator attempted to filter oil or shortening that was not heated. Cold oil and shortening are thicker and cause the pump motor to work harder and overheat.

If the motor hums but the pump does not rotate, there is a blockage in the pump. Incorrectly sized or installed paper will allow food particles and sediment to pass through the filter pan and into the pump. When sediment enters the pump, the gears can bind up causing the motor to overload, again tripping the thermal overload. Solidified shortening in the pump will also cause it to seize, with the same result.

A pump seized by debris or hard shortening can usually be freed by manually moving the gears with a screwdriver or other instrument as illustrated below. **Make sure power to the pump motor is off before trying this.**

1. Disconnect power to the filter system.
2. Remove the input plumbing from the pump.
3. Use a screwdriver to manually turn the gears.
 - Turning the pump gears backwards will release a hard particle and allow its removal.
 - Turning the pump gears forward will push softer objects and solid shortening through the pump and allow free movement of the gears.

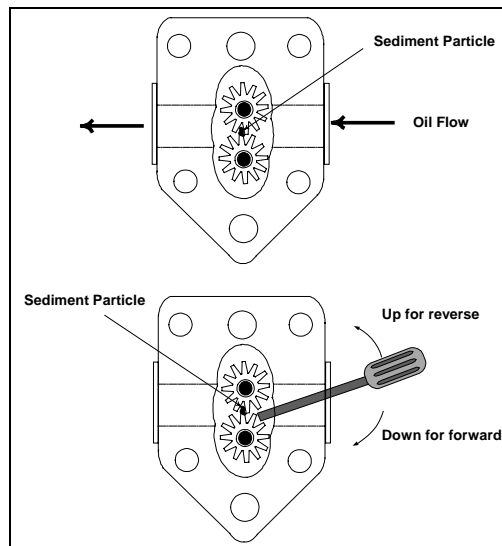

Improperly sized or installed paper will also allow food particles and sediment to pass through and clog the suction tube on the bottom of the filter carriage. Particles large enough to block the suction tube may indicate that the crumb tray is not being used.

Pan blockage can also occur if shortening is left in the pan and allowed to solidify. The heater strip on the suction tube is designed to prevent solidification of residual shortening left in the tube. It will not melt or prevent solidification of shortening in the pan.

Blockage removal can be accomplished by forcing the item out with an auger or drain snake. **NEVER use compressed air or other pressurized gases to force out the blockage.**

The electronics of the FootPrint III system are simple and straightforward. Microswitches, attached to handles for each vat and wired in parallel, provide the 24VAC required to activate the pump relay coil when the handles are moved to the ON position. The activated pump relay coil pulls in the pump motor switch, supplying power to the pump motor.

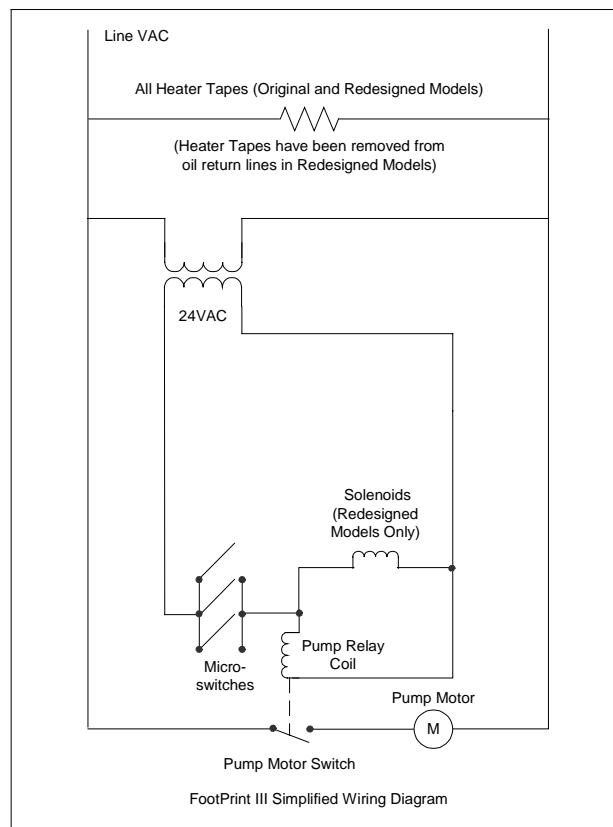

For FootPrint III systems built before August 1997, all heater tapes are wired directly into the line VAC source. They remain energized as long as the unit is plugged in. In systems built in August 1997 and later, oil return line heater tapes have been eliminated. In these units, the only heater tape used is on the suction tube and pump. This tape is still wired directly into the line voltage. A pair of vacuum-breaking solenoids is wired into the 24VAC circuit.

The redesigned FP III is distinguished from original-design units by the absence of casters on the filter base assembly. The redesign incorporated an improved oil return system that allows

oil/shortening to drain back to the filter pan when the filter system is turned off, eliminating the need for most heated oil return components.

Operation of the redesigned FP-III system is the same as for the original design.

ORIGINAL VS REDESIGNED FP-III FILTRATION SYSTEM	
Original System	Redesigned System
Return lines and manifolds wrapped with silicone strip heaters and aluminum tape.	No heater strips or aluminum tape on return lines.
Filter base assembly connected to unit with a black, heated return hose beneath the filter.	Non-heated Teflon hose with a swivel joint connects the filter base assembly to the unit above the filter.
Filter base assembly equipped with swivel casters.	Filter base assembly has no casters.
Operator-removable filter base assembly. (Filter base assembly stoplocks in cabinet can be rotated to remove tray.)	Filter base assembly is not removable except by a qualified service technician. (Filter base assembly stoplocks fitted with a screw and nut to prevent filter removal.)
Oil/shortening remains in return lines when filter system is turned off.	Oil/shortening gravity-drains back to the filter pan when filter system is turned off, leaving no oil or shortening in return lines.

Square Drain Sub-System

The only change to the square drain sub-system is the addition of a ¼” NPT vent coupling to the leftmost end sections to allow attachment to a vacuum-breaking solenoid. The new end sections may also be used on the original-design filtration system by plugging the vent port with a ¼” NPT pipe plug coated with sealant. All other square drain components remain unchanged.

Rear-Flush Sub-System

A one-piece, welded rear manifold and Dormont stainless steel flexlines replace the various pieces of ½” NPT piping, flexlines, and heater-strips used on the original-design filtration system. A solenoid vent valve is attached at the left end of the oil return manifold mounted at the rear of the leftmost two frypots. It prevents vacuum-lock of the system as oil/shortening drains back to the filter pan when the unit is turned off. The solenoid valve is connected to the square drain sub-system by a clear ⅜” O.D. Teflon tube and threaded fittings. The Gemini ball valve used on the manifold is the same as that used on the earlier design. Eight and one-half-inch stainless steel Dormont flexlines replace the flexlines that connect the manifolds to the valves. Standard ½” X ½” X 90° black metal street elbows are used to make the connections.

Filter Base Assembly and Pump Sub-System

Casters are not present on the new-design filter base. In addition, the filter base assembly has been redesigned to prevent it being taken out of the cabinet without removing a set of machine screws and nuts. The filter pan is unchanged and is completely removable.

A new Teflon hose with a braided stainless steel covering connects the pump to the rear manifold and replaces the heated hose running from the pump discharge under the unit to the Power Shower plumbing. The new hose is fitted with a 90° swivel at the manifold end and a straight swivel at the pump end to prevent kinking.

The pump plumbing has been changed by the addition of a solenoid valve at the pump discharge, a ¼” I.D. Dormont stainless steel flexline that connects the solenoid valve to the pump inlet fittings,

and miscellaneous standard black metal fittings for connections. This design allows oil/shortening to bypass the pump as it drains from the oil return lines back into the filter pan when the system is turned off. Bypassing the pump expedites draining of the lines. The pump solenoid leads are connected to Pins 7 and 9 of the upper 9-pin plug assembly.

Filter Wiring Box

The original-design 5-lead cable connecting the filter assembly to the filter wiring box has been replaced with a new, universal 7-lead cable to accommodate the solenoid mounted on the front manifold. The two new leads have a separate connector for attachment to the solenoid. When a filter cable is ordered for either filtration system configuration (original or redesigned), the new 7-wire cable will be sent. The two extra wires and connector will not interfere with the original filtration system or its operation.

Verifying Solenoid Operation

Proper operation of the 24VAC manifold and pump solenoids can be verified by removing the pump motor lead from terminal 4 of the pump motor relay in the filter wiring box and then activating the oil return lever. Proper solenoid operation will be evidenced by an audible “click” or vibration of both the pump solenoid and the manifold solenoid.

3.7.6 Leakage Problems

Leakage of the frypot will usually be due to improperly sealed high limit thermostats, temperature probes, and drain fittings. When installed or replaced, each of these components must be sealed with Loctite® PST56765 sealant or equivalent to prevent leakage. In very rare cases, a leak may develop along one of the welded edges of the frypot. When this occurs, the frypot must be replaced.

If the sides and/or ends of the frypot are coated with oil/shortening, the most likely cause is spillage over the top of the frypot rather than leakage.

The clamps, which hold the drain tube sections together, may loosen over time as the tubes expand and contract with heating and cooling during use. If the section of drain tube connected to the drain valve is removed for whatever reason, make sure that its o-ring is in good condition and properly fitted around the nipple of the drain section when it is reinstalled. Also, check to insure that the drain tube runs downward from the drain along its whole length and has no low points where oil or shortening may accumulate.

3.8 Troubleshooting Guides

The troubleshooting guides found in the pages that follow are intended to assist service technicians in quickly isolating the probable causes of equipment malfunctions by following a logical, step-by-step process.

3.8.1 Troubleshooting the 24VAC Circuit

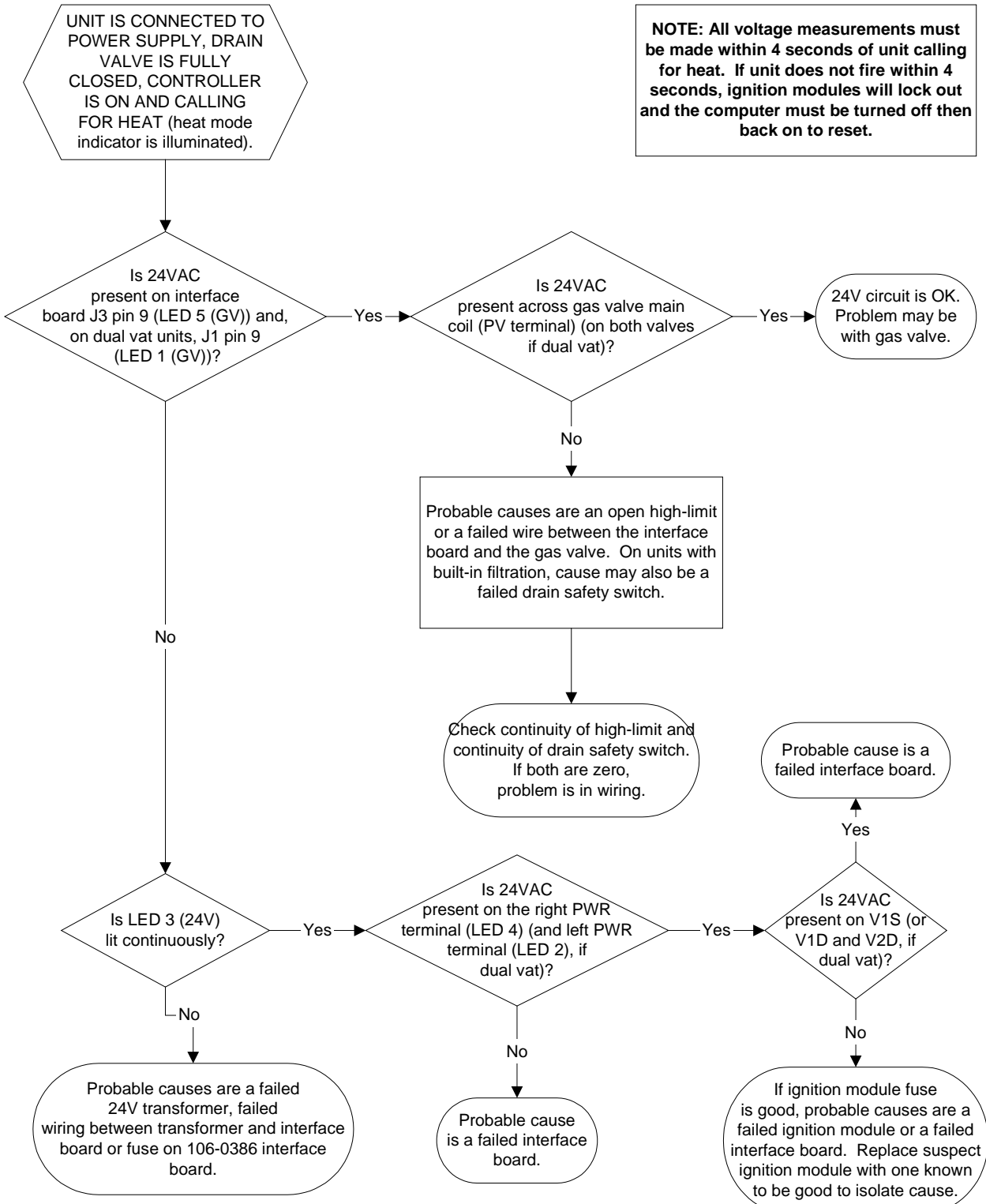

24 VOLT CIRCUIT
 With Interface Board 806-3398 or 106-0386 and
 Two 807-1006 (FV/DV), 807-2971 (FV/DV), or 807-3365 (DV) Ignition Modules

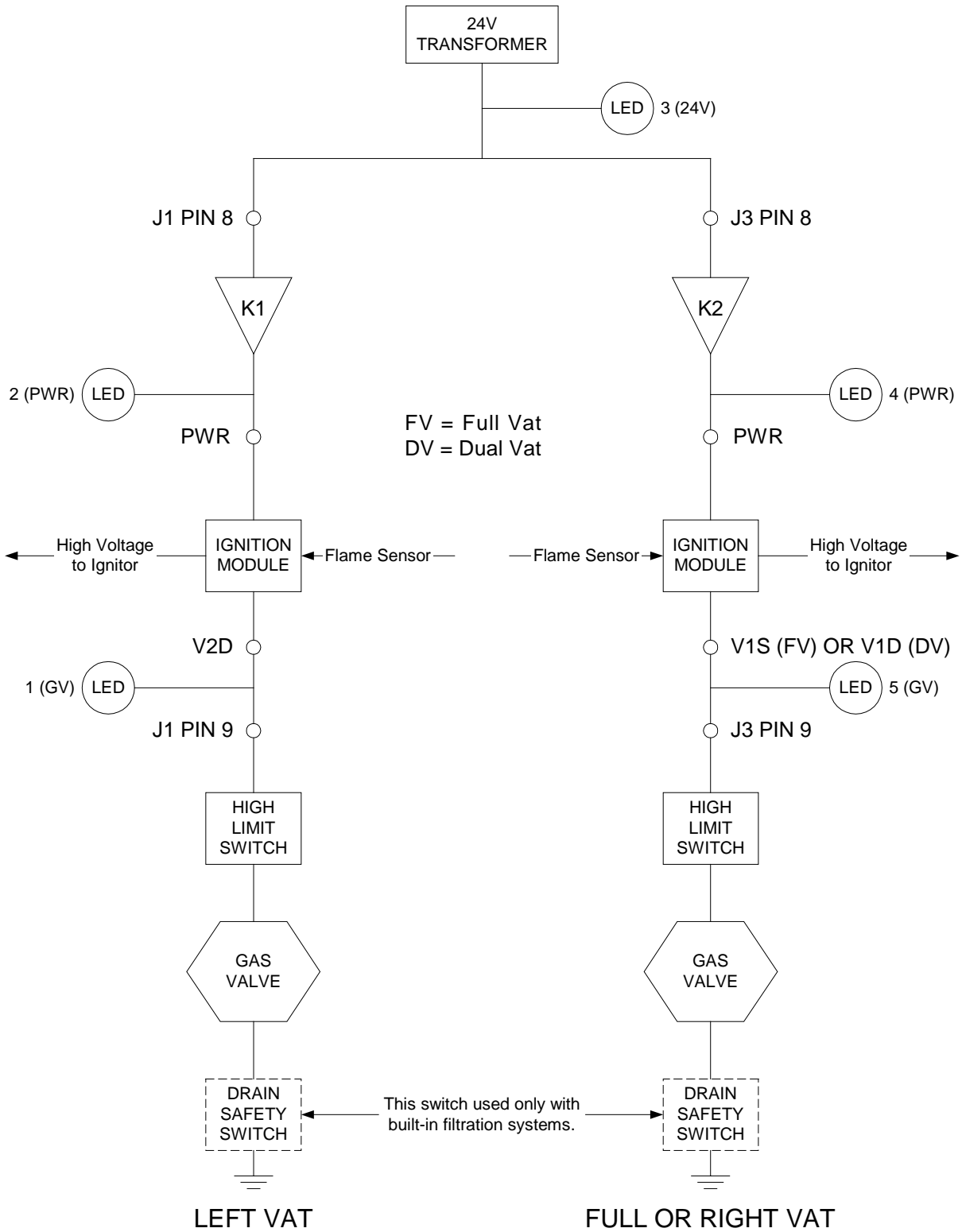

24 VOLT CIRCUIT

With Interface Board 806-3398 or 106-0386 and
One 807-3366 (FV) Ignition Module

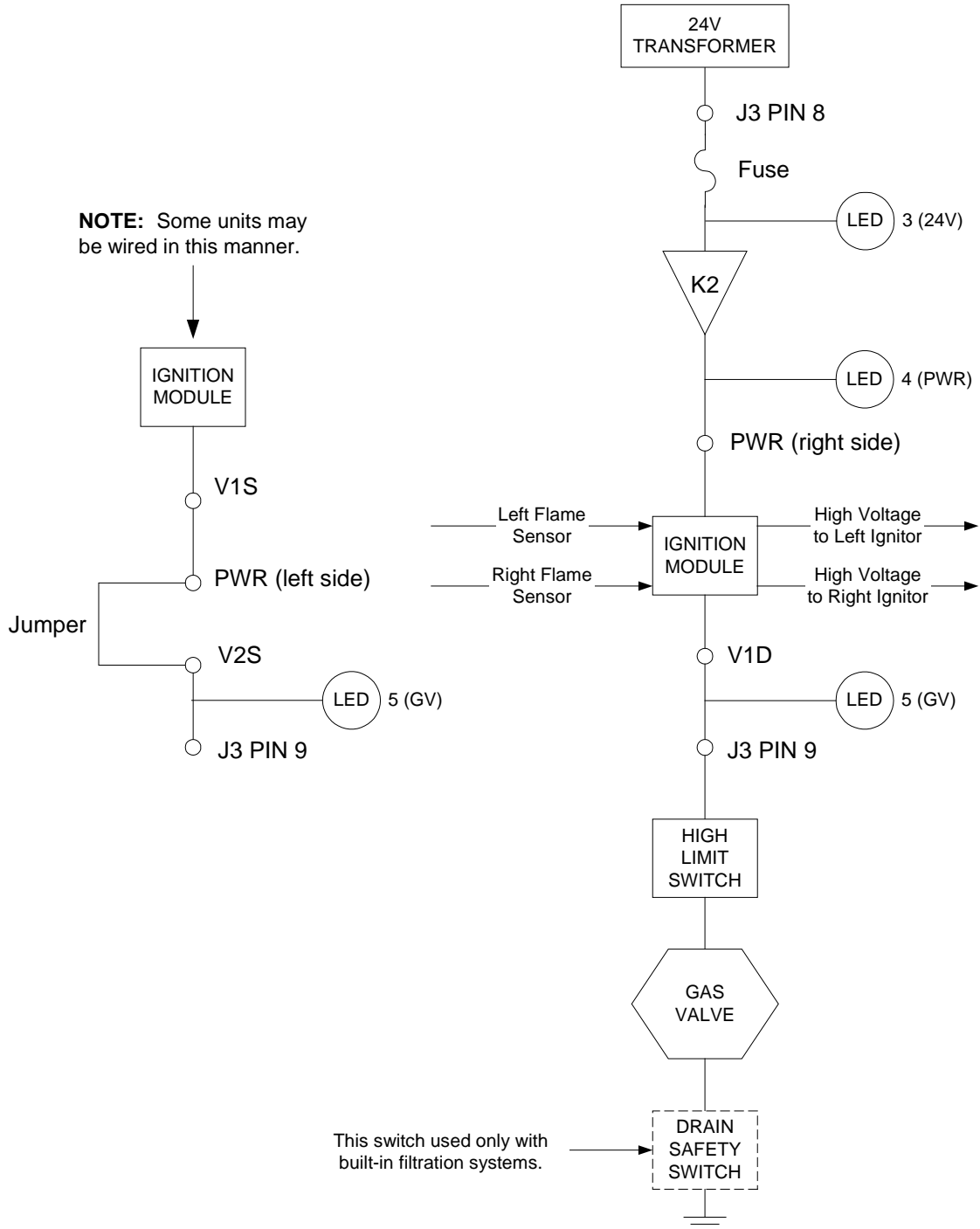

3.8.2 Troubleshooting the Gas Valve

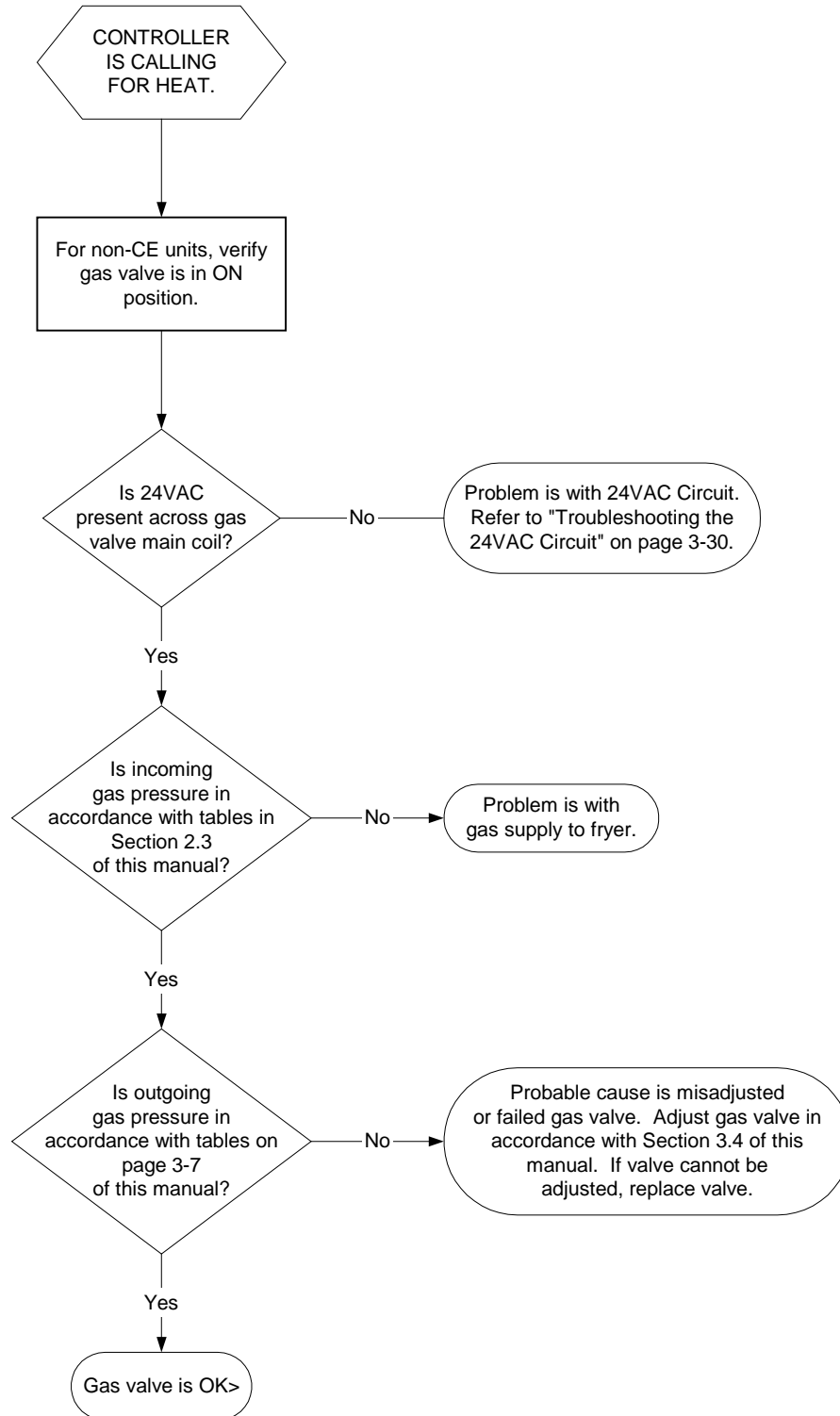

3.8.3 Troubleshooting the Temperature Probe

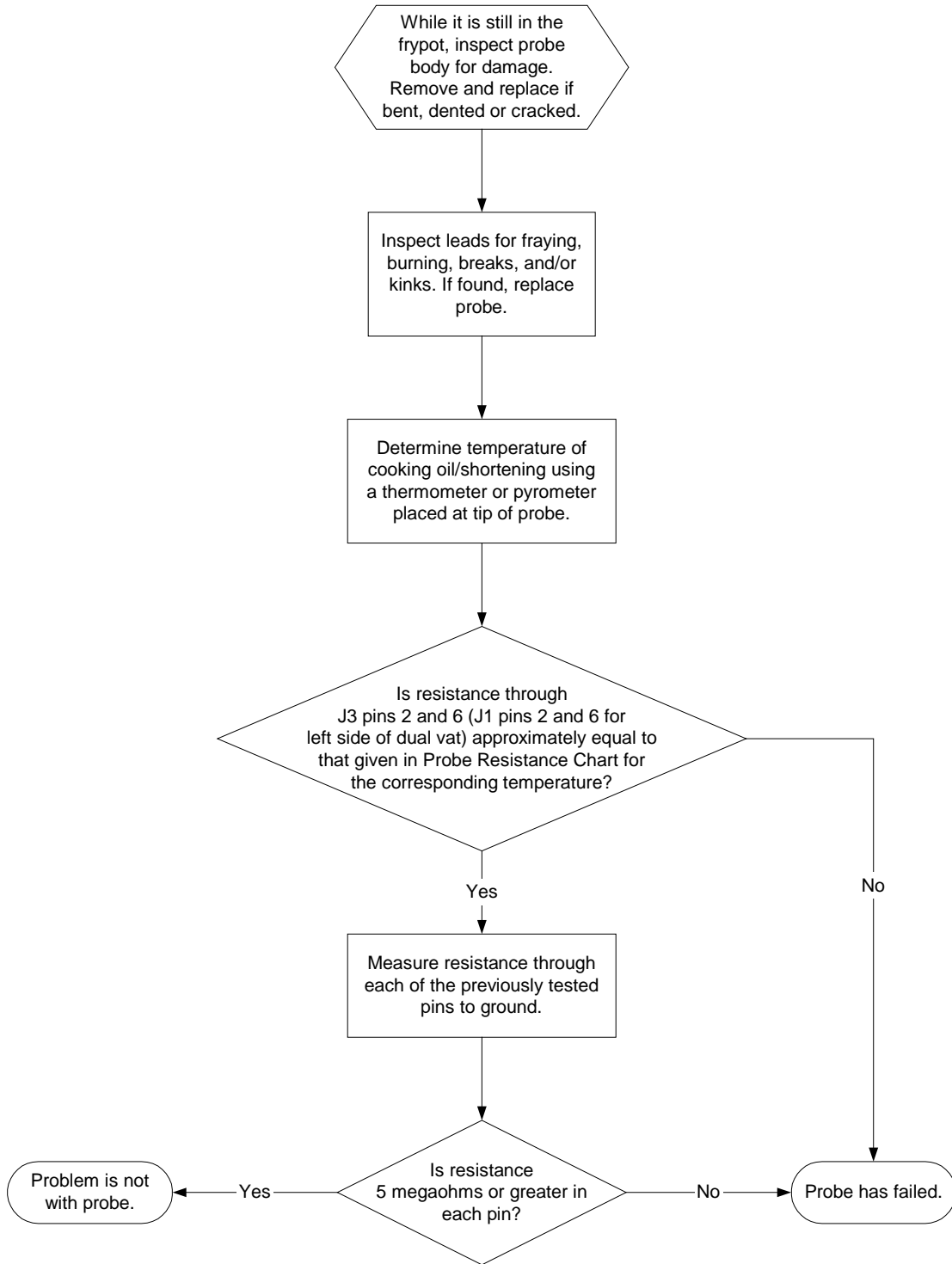

Note: Disconnect computer before measuring probe resistance.

3.9 Probe Resistance Chart

<h2 style="text-align: center;">Probe Resistance Chart</h2> <p style="text-align: center;"><i>For use with H52 Series fryers manufactured with Minco Thermistor probes only.</i></p>														
F	OHMS	C	F	OHMS	C	F	OHMS	C	F	OHMS	C	F	OHMS	C
32	1000	0	83	1107	28	134	1214	57	185	1320	85	236	1424	113
33	1002	1	84	1110	29	135	1216	57	186	1322	86	237	1426	114
34	1004	1	85	1112	29	136	1218	58	187	1324	86	238	1428	114
35	1006	2	86	1114	30	137	1220	58	188	1326	87	239	1430	115
36	1008	2	87	1116	31	138	1222	59	189	1328	87	240	1432	116
37	1011	3	88	1118	31	139	1224	59	190	1330	88	241	1434	116
38	1013	3	89	1120	32	140	1226	60	191	1332	88	242	1436	117
39	1015	4	90	1122	32	141	1229	61	192	1334	89	243	1438	117
40	1017	4	91	1124	33	142	1231	61	193	1336	89	244	1440	118
41	1019	5	92	1126	33	143	1233	62	194	1338	90	245	1442	118
42	1021	6	93	1128	34	144	1235	62	195	1340	91	246	1444	119
43	1023	6	94	1131	34	145	1237	63	196	1342	91	247	1447	119
44	1025	7	95	1133	35	146	1239	63	197	1344	92	248	1449	120
45	1027	7	96	1135	36	147	1241	64	198	1346	92	249	1451	121
46	1030	8	97	1137	36	148	1243	64	199	1348	93	250	1453	121
47	1032	8	98	1139	37	149	1245	65	200	1350	93	251	1455	122
48	1034	9	99	1141	37	150	1247	66	201	1352	94	252	1457	122
49	1036	9	100	1143	38	151	1249	66	202	1354	94	253	1459	123
50	1038	10	101	1145	38	152	1251	67	203	1357	95	254	1461	123
51	1040	11	102	1147	39	153	1253	67	204	1359	96	255	1463	124
52	1042	11	103	1149	39	154	1255	68	205	1361	96	256	1465	124
53	1044	12	104	1151	40	155	1258	68	206	1363	97	257	1467	125
54	1046	12	105	1154	41	156	1260	69	207	1365	97	258	1469	126
55	1049	13	106	1156	41	157	1262	69	208	1367	98	259	1471	126
56	1051	13	107	1158	42	158	1264	70	209	1369	98	260	1473	127
57	1053	14	108	1160	42	159	1266	71	210	1371	99	261	1475	127
58	1055	14	109	1162	43	160	1268	71	211	1373	99	262	1477	128
59	1057	15	110	1164	43	161	1270	72	212	1375	100	263	1479	128
60	1059	16	111	1166	44	162	1272	72	213	1377	101	264	1481	129
61	1061	16	112	1168	44	163	1274	73	214	1379	101	265	1483	129
62	1063	17	113	1170	45	164	1276	73	215	1381	102	266	1485	130
63	1065	17	114	1172	46	165	1278	74	216	1383	102	267	1487	131
64	1068	18	115	1174	46	166	1280	74	217	1385	103	268	1489	131
65	1070	18	116	1176	47	167	1282	75	218	1387	103	269	1491	132
66	1072	19	117	1179	47	168	1284	76	219	1389	104	270	1493	132
67	1074	19	118	1181	48	169	1287	76	220	1391	104	271	1495	133
68	1076	20	119	1183	48	170	1289	77	221	1393	105	272	1497	133
69	1078	21	120	1185	49	171	1291	77	222	1395	106	273	1499	134
70	1080	21	121	1187	49	172	1293	78	223	1398	106	274	1501	134
71	1082	22	122	1189	50	173	1295	78	224	1400	107	275	1503	135
72	1084	22	123	1191	51	174	1297	79	225	1402	107	276	1505	136
73	1086	23	124	1193	51	175	1299	79	226	1404	108	277	1507	136
74	1089	23	125	1195	52	176	1301	80	227	1406	108	278	1509	137
75	1091	24	126	1197	52	177	1303	81	228	1408	109	279	1512	137
76	1093	24	127	1199	53	178	1305	81	229	1410	109	280	1514	138
77	1095	25	128	1201	53	179	1307	82	230	1412	110	281	1516	138
78	1097	26	129	1203	54	180	1309	82	231	1414	111	282	1518	139
79	1099	26	130	1204	54	181	1311	83	232	1416	111	283	1520	139
80	1101	27	131	1206	55	182	1313	83	233	1418	112	284	1522	140
81	1103	27	132	1208	56	183	1315	84	234	1420	112	285	1524	141
82	1105	28	133	1210	56	184	1317	84	235	1422	113	286	1526	141

Probe Resistance Chart (Continued)

For use with H52 Series fryers manufactured with Minco Thermistor probes only.

F	OHMS	C	F	OHMS	C	F	OHMS	C	F	OHMS	C	F	OHMS	C
287	1528	142	338	1630	170	389	1732	198	440	1833	227	491	1932	255
288	1530	142	339	1632	171	390	1734	199	441	1835	227	492	1934	256
289	1532	143	340	1634	171	391	1736	199	442	1837	228	493	1936	256
290	1534	143	341	1636	172	392	1738	200	443	1839	228	494	1938	257
291	1536	144	342	1638	172	393	1740	201	444	1841	229	495	1940	257
292	1538	144	343	1640	173	394	1742	201	445	1843	229	496	1942	258
293	1540	145	344	1642	173	395	1744	202	446	1845	230	497	1944	258
294	1542	146	345	1644	174	396	1746	202	447	1846	231	498	1946	259
295	1544	146	346	1646	174	397	1748	203	448	1848	231	499	1948	259
296	1546	147	347	1648	175	398	1750	203	449	1850	232	500	1950	260
297	1548	147	348	1650	176	399	1752	204	450	1852	232	501	1952	261
298	1550	148	349	1652	176	400	1754	204	451	1854	233	502	1954	261
299	1552	148	350	1654	177	401	1756	205	452	1856	233	503	1956	262
300	1554	149	351	1656	177	402	1758	206	453	1858	234	504	1958	262
301	1556	149	352	1658	178	403	1760	206	454	1860	234	505	1960	263
302	1558	150	353	1660	178	404	1762	207	455	1862	235	506	1962	263
303	1560	151	354	1662	179	405	1764	207	456	1864	236	507	1964	264
304	1562	151	355	1664	179	406	1766	208	457	1866	236	508	1965	264
305	1564	152	356	1666	180	407	1768	208	458	1868	237	509	1967	265
306	1566	152	357	1668	181	408	1770	209	459	1870	237	510	1969	266
307	1568	153	358	1670	181	409	1772	209	460	1872	238	511	1971	266
308	1570	153	359	1672	182	410	1774	210	461	1874	238	512	1973	267
309	1572	154	360	1674	182	411	1776	211	462	1876	239	513	1975	267
310	1574	154	361	1676	183	412	1778	211	463	1878	239	514	1977	268
311	1576	155	362	1678	183	413	1780	212	464	1880	240	515	1979	268
312	1578	156	363	1680	184	414	1781	212	465	1882	241	516	1981	269
313	1580	156	364	1682	184	415	1783	213	466	1884	241	517	1983	269
314	1582	157	365	1684	185	416	1785	213	467	1886	242	518	1985	270
315	1584	157	366	1686	186	417	1787	214	468	1888	242	519	1987	271
316	1586	158	367	1688	186	418	1789	214	469	1890	243	520	1989	271
317	1588	158	368	1690	187	419	1791	215	470	1892	243	521	1991	272
318	1590	159	369	1692	187	420	1793	216	471	1893	244	522	1993	272
319	1592	159	370	1694	188	421	1795	216	472	1895	244	523	1995	273
320	1594	160	371	1696	188	422	1797	217	473	1897	245	524	1996	273
321	1596	161	372	1698	189	423	1799	217	474	1899	246	525	1998	274
322	1598	161	373	1700	189	424	1801	218	475	1901	246	526	2000	274
323	1600	162	374	1702	190	425	1803	218	476	1903	247	527	2002	275
324	1602	162	375	1704	191	426	1805	219	477	1905	247	528	2004	276
325	1604	163	376	1706	191	427	1807	219	478	1907	248	529	2006	276
326	1606	163	377	1708	192	428	1809	220	479	1909	248	530	2008	277
327	1608	164	378	1710	192	429	1811	221	480	1911	249	531	2010	277
328	1610	164	379	1712	193	430	1813	221	481	1913	249	532	2012	278
329	1612	165	380	1714	193	431	1815	222	482	1915	250	533	2014	278
330	1614	166	381	1716	194	432	1817	222	483	1917	251	534	2016	279
331	1616	166	382	1718	194	433	1819	223	484	1919	251	535	2018	279
332	1618	167	383	1720	195	434	1821	223	485	1921	252	536	2020	280
333	1620	167	384	1722	196	435	1823	224	486	1923	252	537	2022	281
334	1622	168	385	1724	196	436	1825	224	487	1925	253	538	2025	281
335	1624	168	386	1726	197	437	1827	225	488	1927	253	539	2027	282
336	1626	169	387	1728	197	438	1829	226	489	1929	254	540	2029	282
337	1628	169	388	1730	198	439	1831	226	490	1931	254	541	2031	283

3.10 Simplified Wiring Diagrams

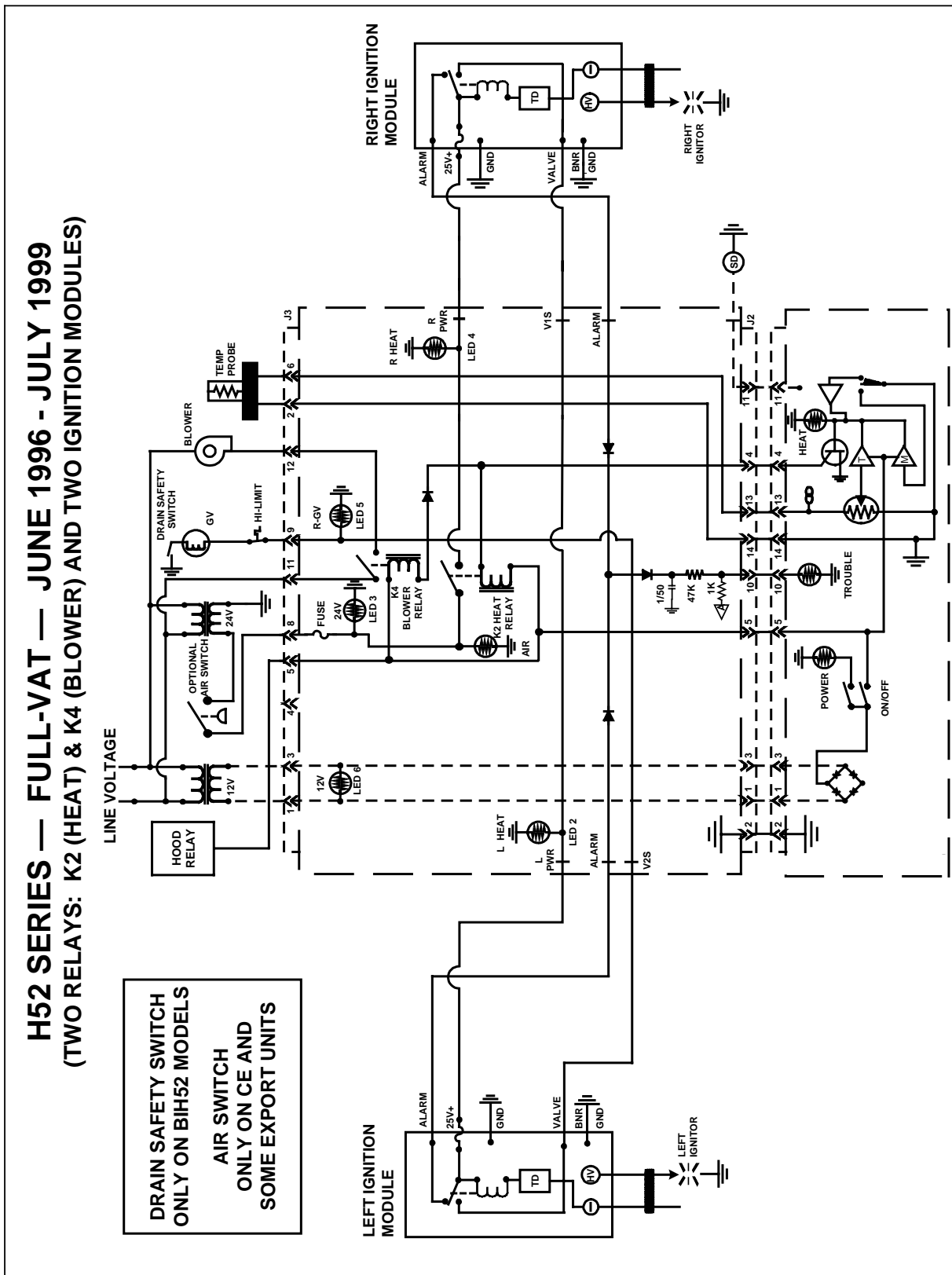

H52 SERIES— FULL-VAT— BEFORE JUNE 1996 & AFTER JULY 1999 (ONE DUAL FUNCTION HEAT/BLOWER RELAY (K3) AND TWO IGNITION MODULES)

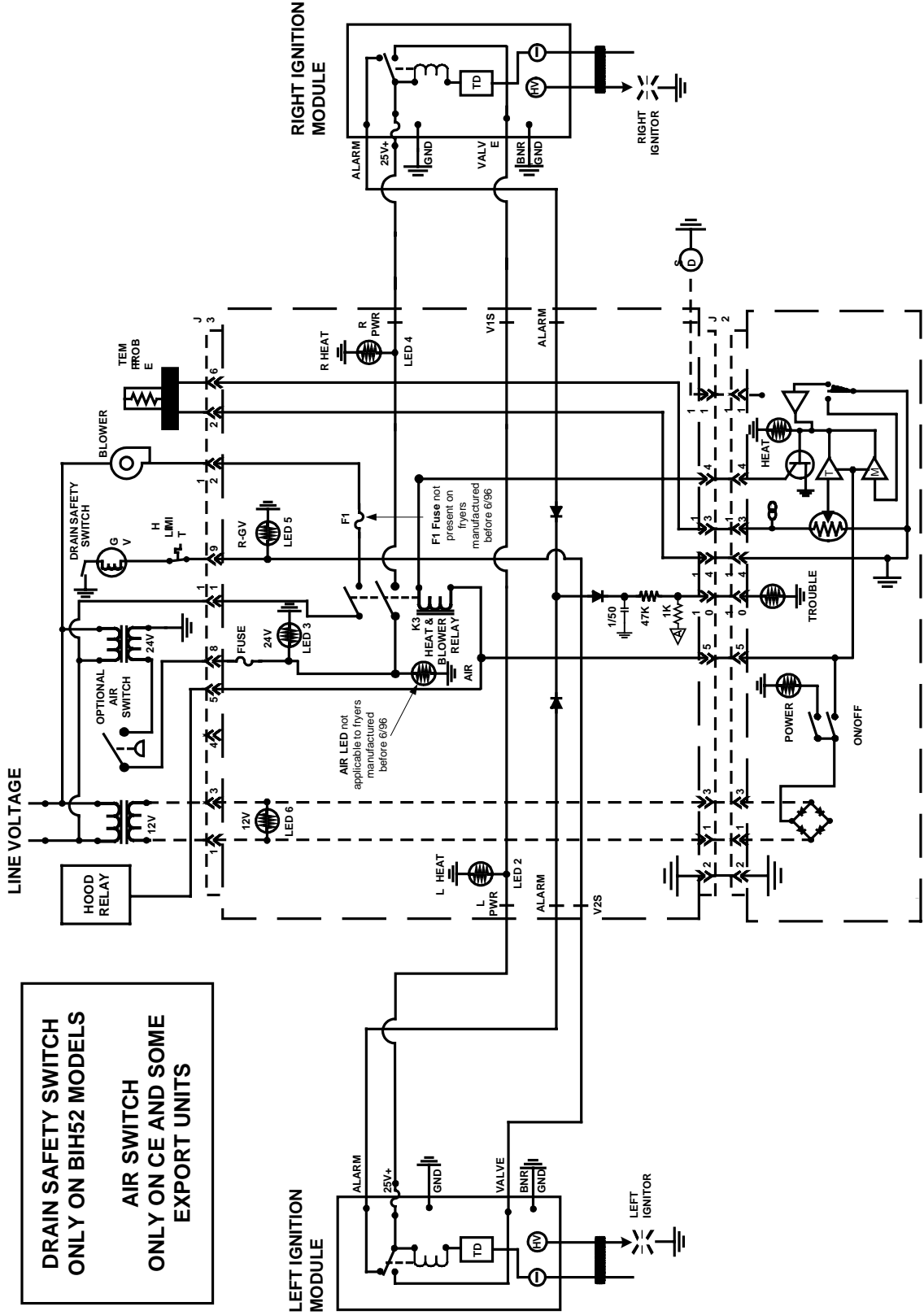

**DRAIN SAFETY SWITCH
ONLY ON BIH52 MODELS**

**AIR SWITCH
ONLY ON CE AND SOME
EXPORT UNITS**

H52 SERIES— FULL-VAT WITH ONE DUAL-SPARK IGNITION MODULE (ONE DUAL FUNCTION HEAT/BLOWER RELAY (K3))

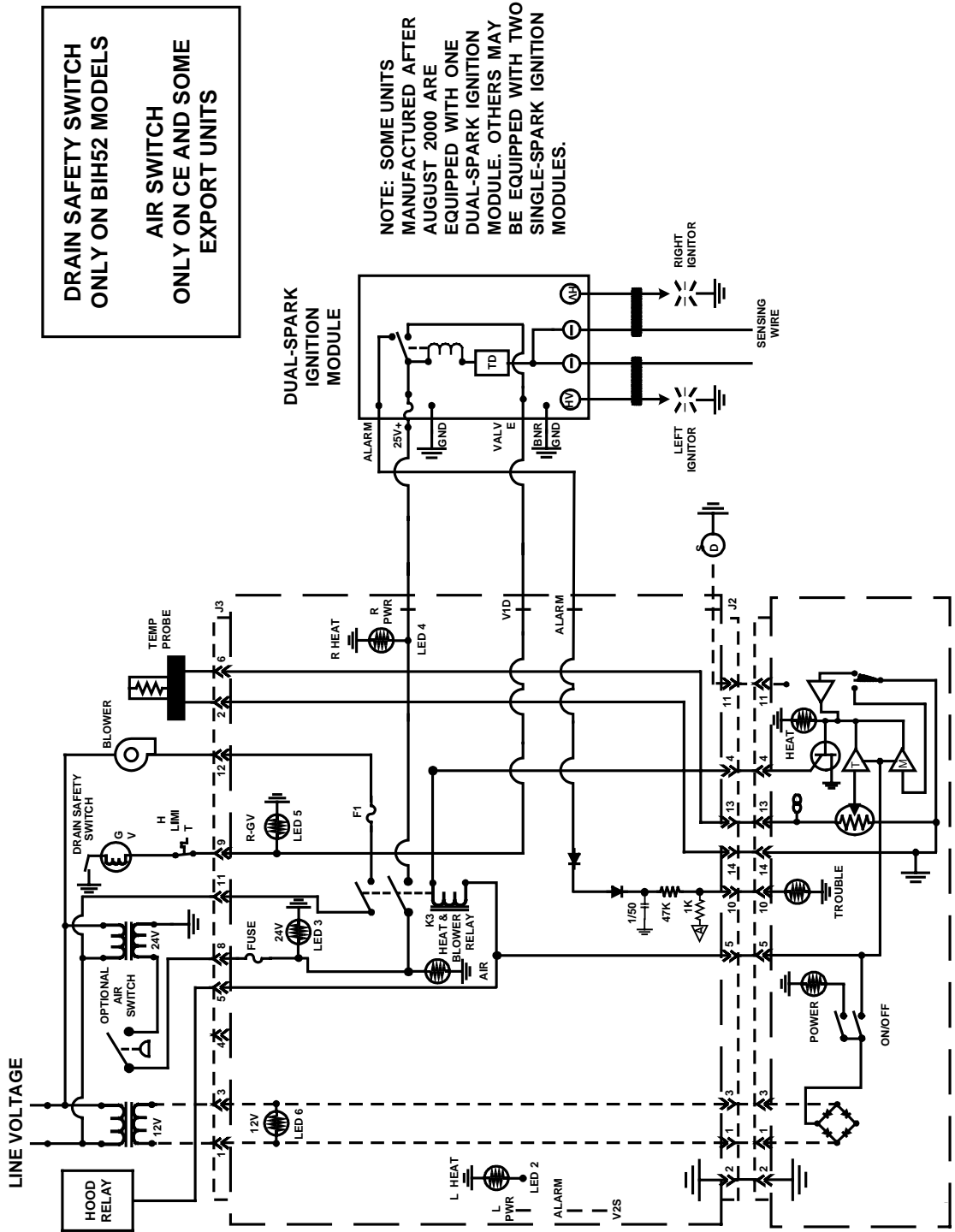

H52 SERIES — DUAL-VAT — JUNE 1996 - JULY 1999
(THREE RELAYS: K1 & K2 (HEAT) AND K4 (BLOWER))

**DRAIN SAFETY SWITCH
 ONLY ON BIH52
 MODELS**

**AIR SWITCH
 ONLY ON CE AND
 SOME EXPORT UNITS**

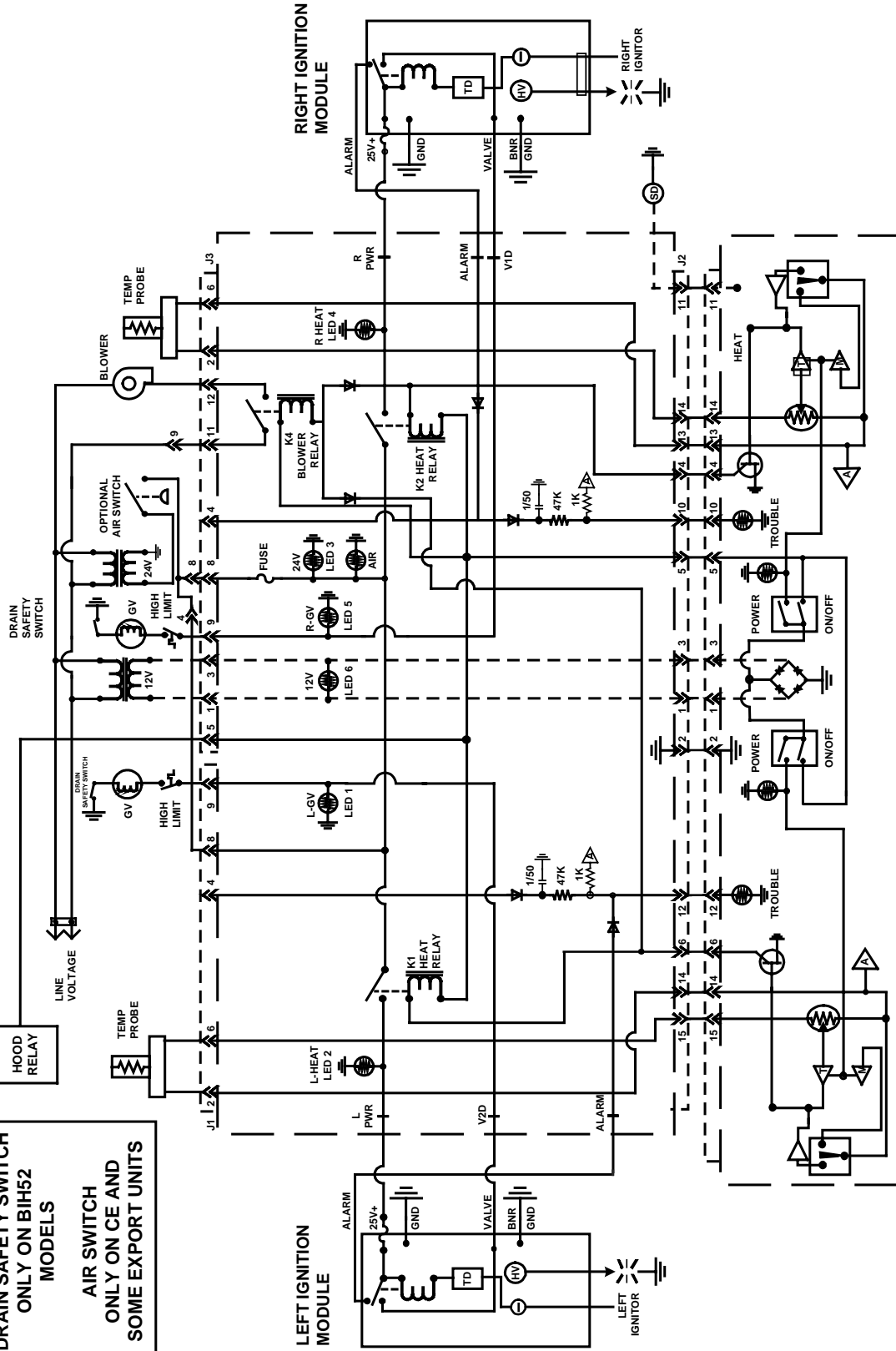

H52 SERIES — DUAL-VAT — BEFORE JUNE 1996 & AFTER JULY 1999 (TWO DUAL-FUNCTION HEAT/BLOWER RELAYS (K1 & K2) AND TWO IGNITION MODULES)

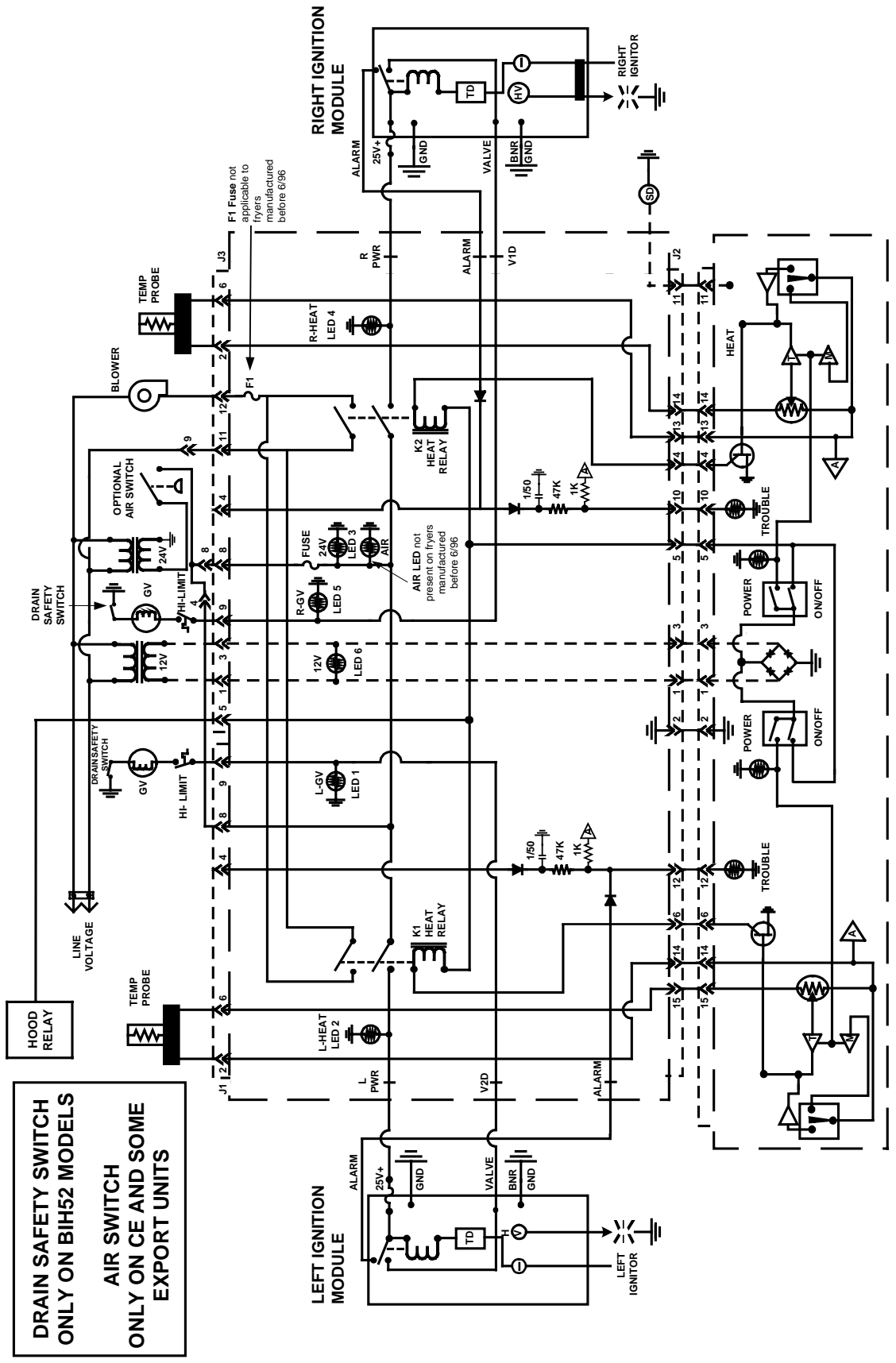

3.11 Principal Wiring Connections

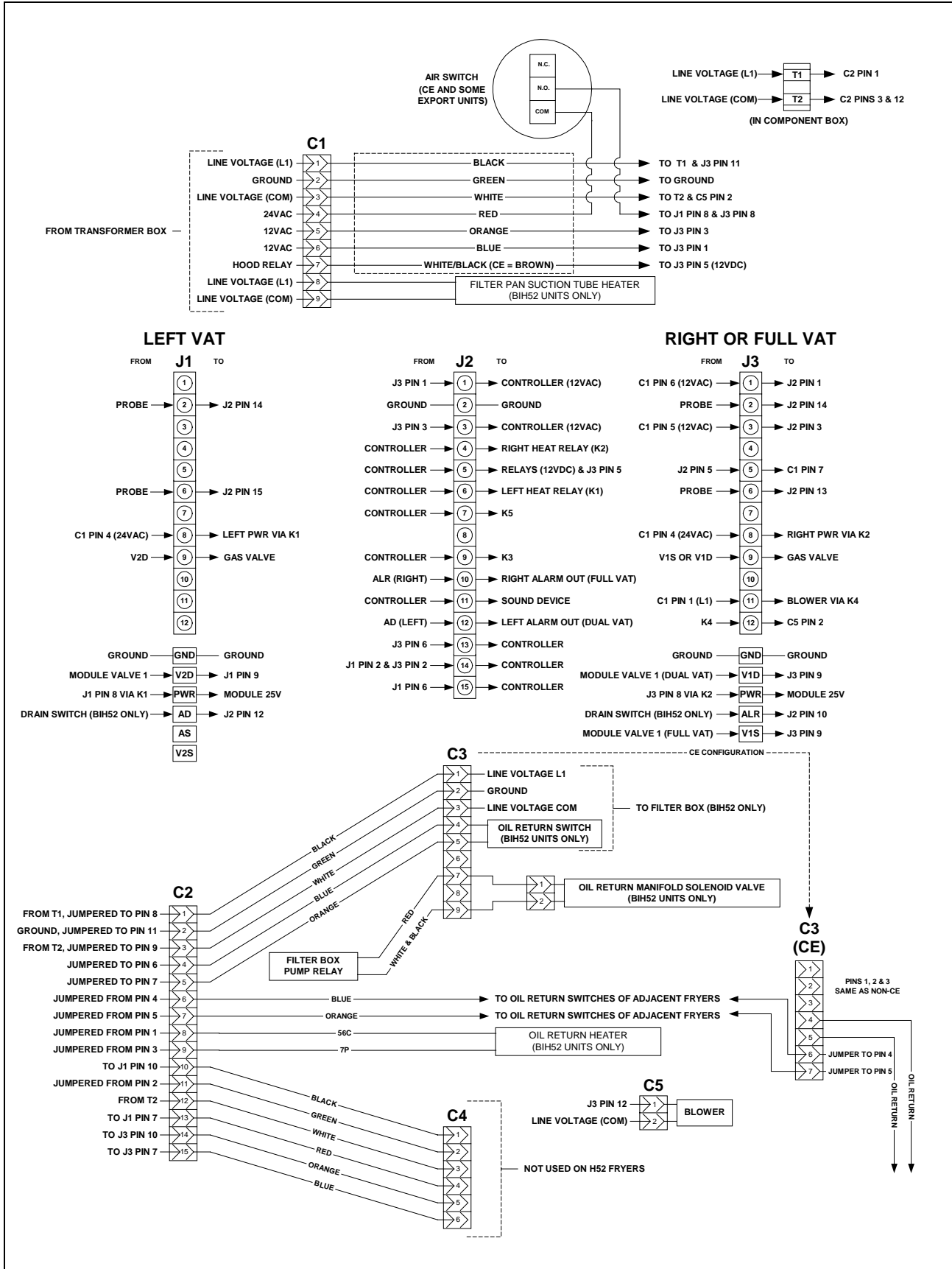

3.12 Main Wiring Diagrams

BIH152 Main Wiring Diagram (U.S., CE, and Non-CE Export)

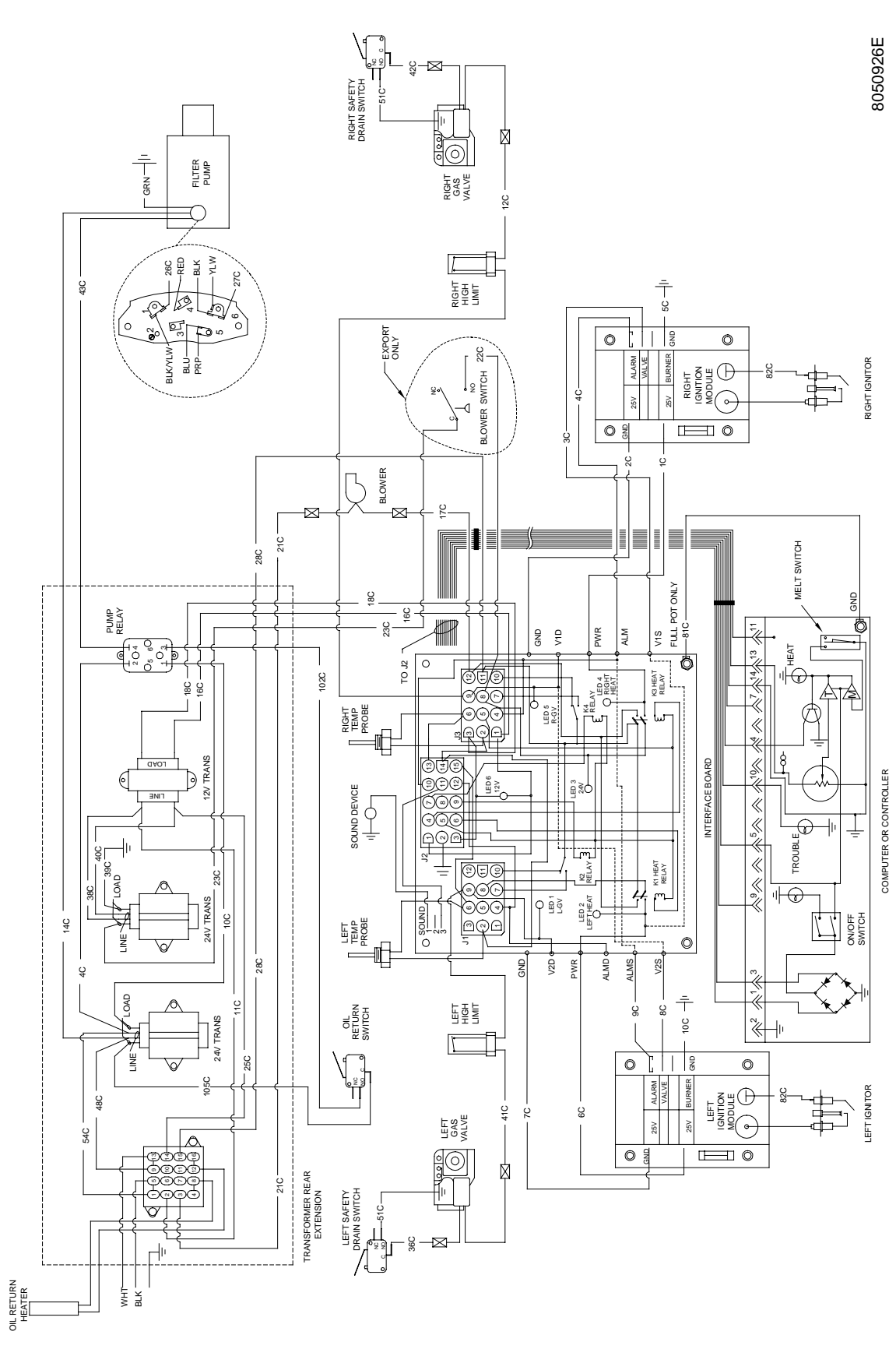

8050926E

BIH52/MH52 Main Wiring Diagram (U.S. and Non-CE Export)

Old Single-Spark Ignition Module

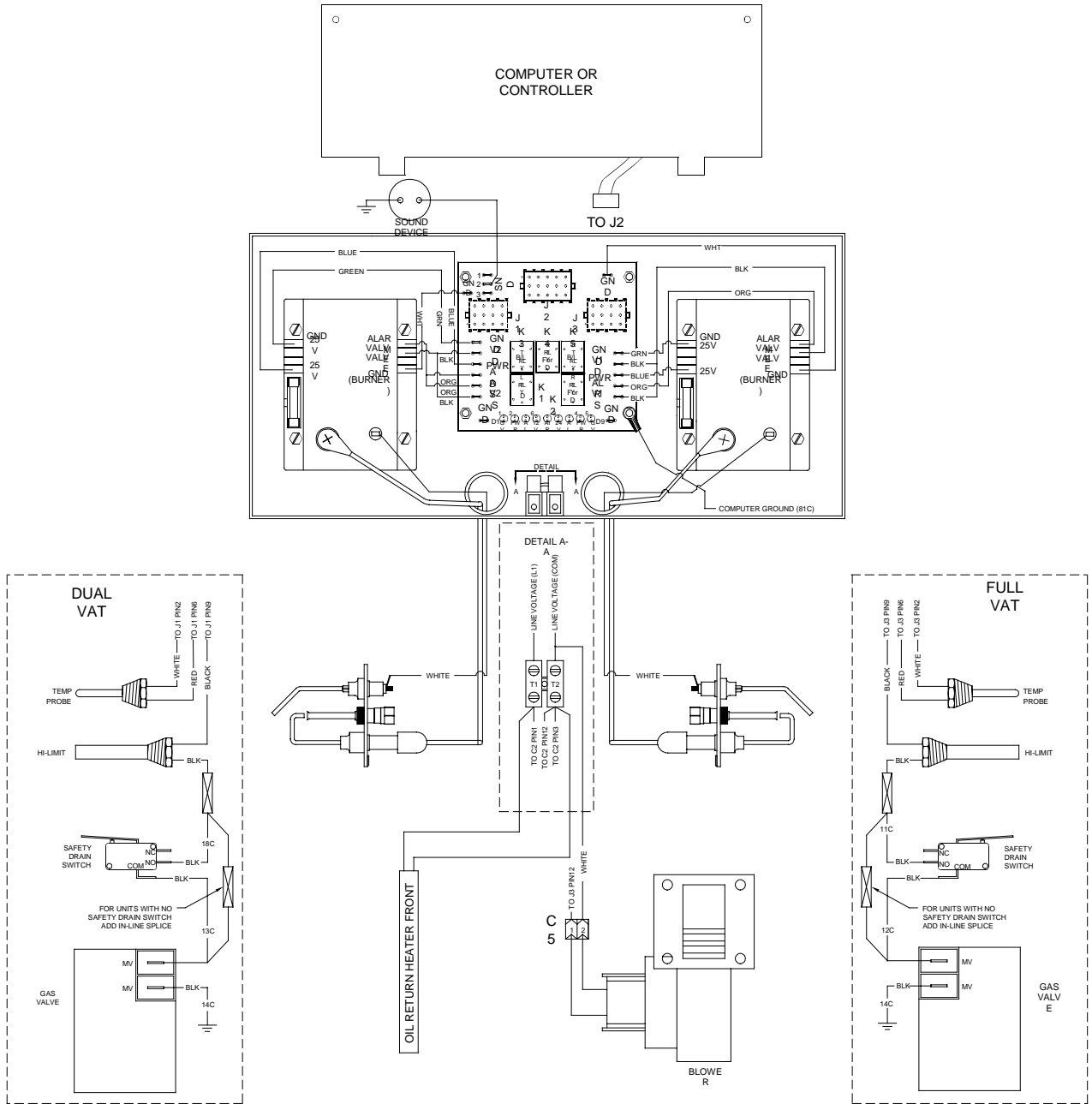

Refer to "PRINCIPAL WIRING CONNECTIONS" on Page 3-42 for detail of connection points J1, J2, J3, C2, C3, and C5.

8050502G

BIH52/MH52 Main Wiring Diagram (U.S. and Non-CE Export)

New Dual-Spark Ignition Module

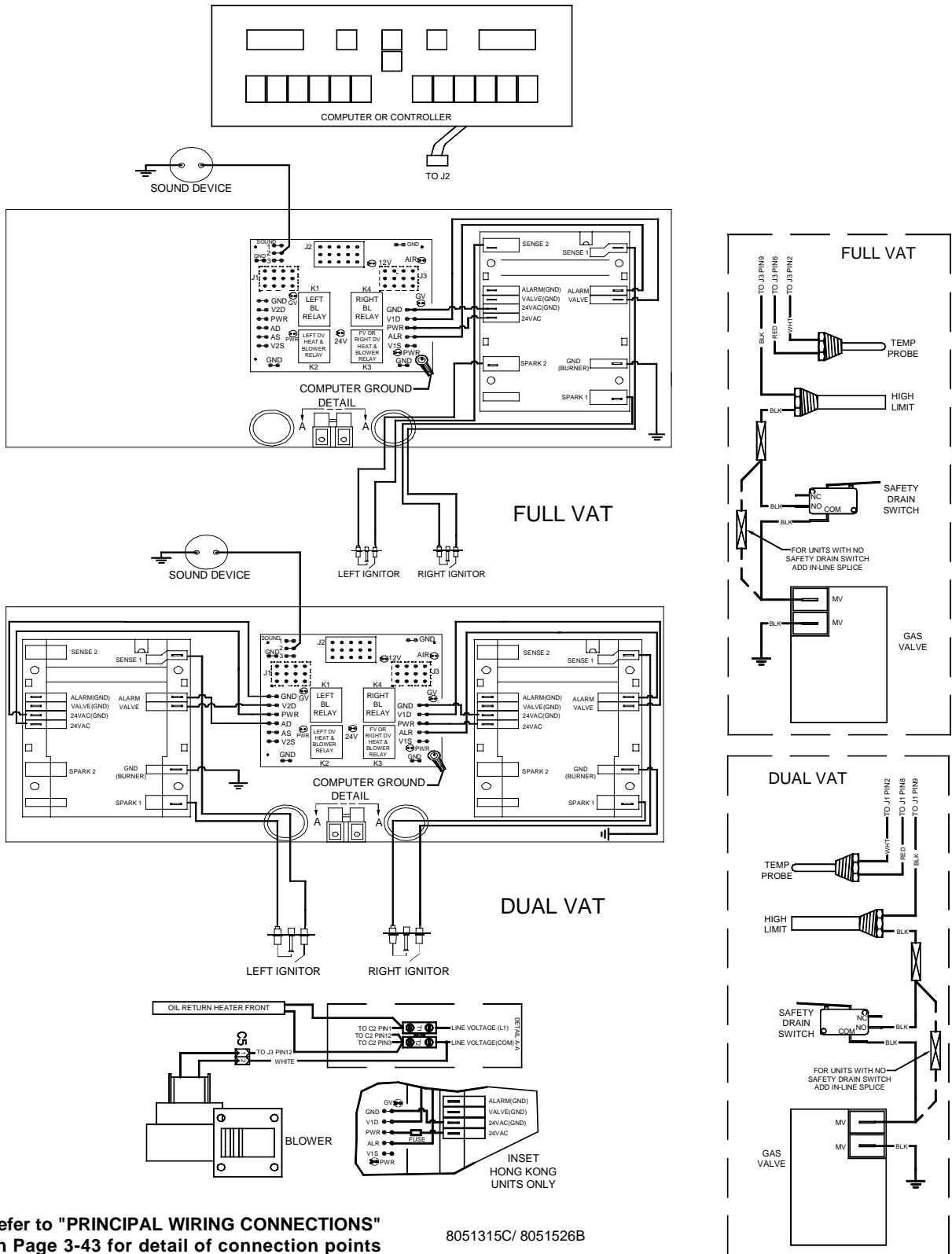

Refer to "PRINCIPAL WIRING CONNECTIONS" on Page 3-43 for detail of connection points J1, J2, J3, C2, C3, and C5.

8051315C/ 8051526B

BIH52/MH52 Main Wiring Diagram (CE)

Old Single-Spark Ignition Module

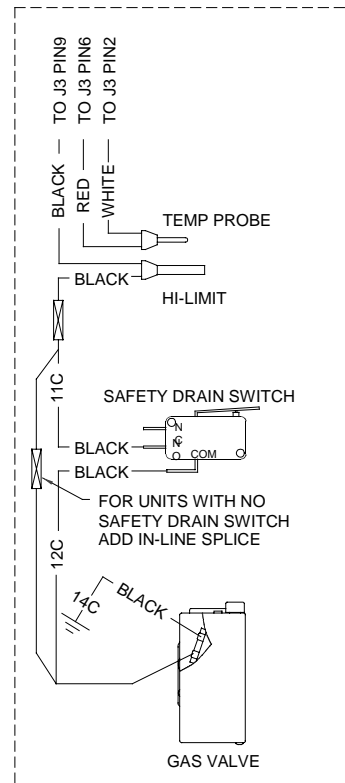
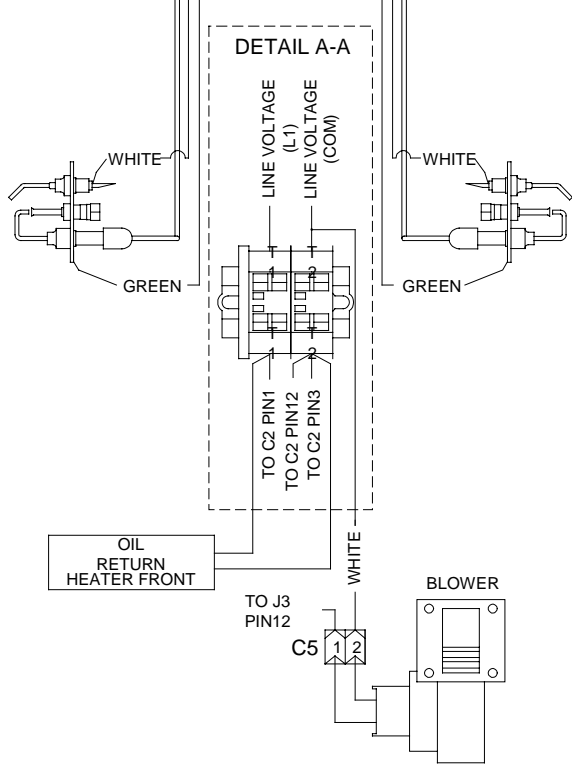
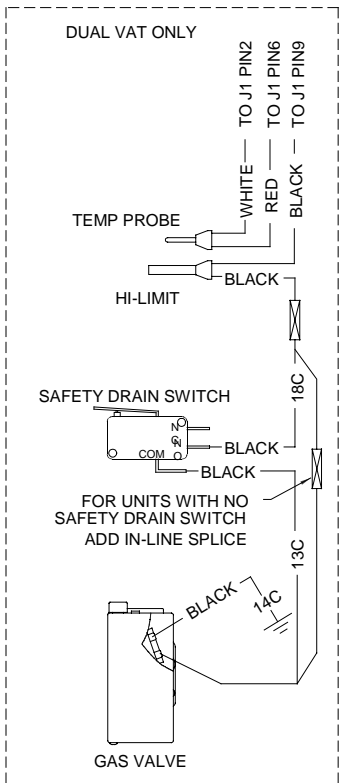
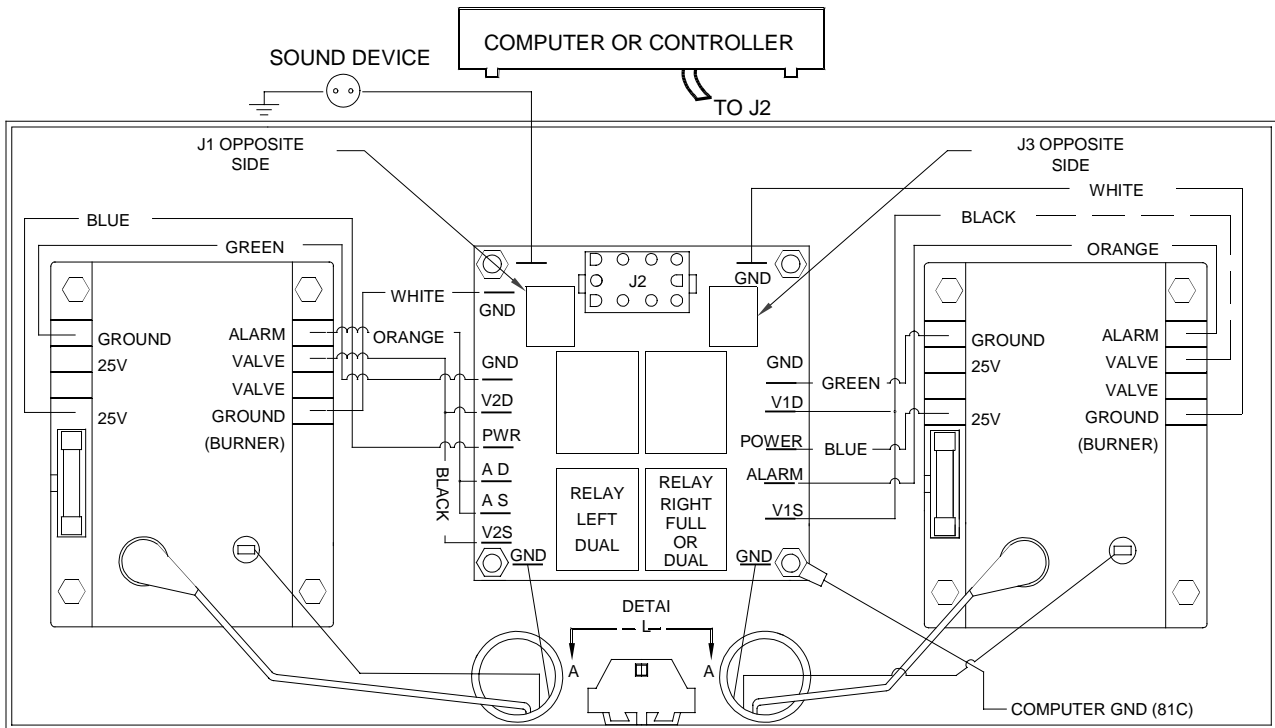

Refer to "PRINCIPAL WIRING CONNECTIONS" on Page 3-42 for detail of connection points J1, J2, J3, C2, C3, and C5.

8050526D

BIH52 Filter Box Wiring Diagram (U.S., CE, and Non-CE Export)

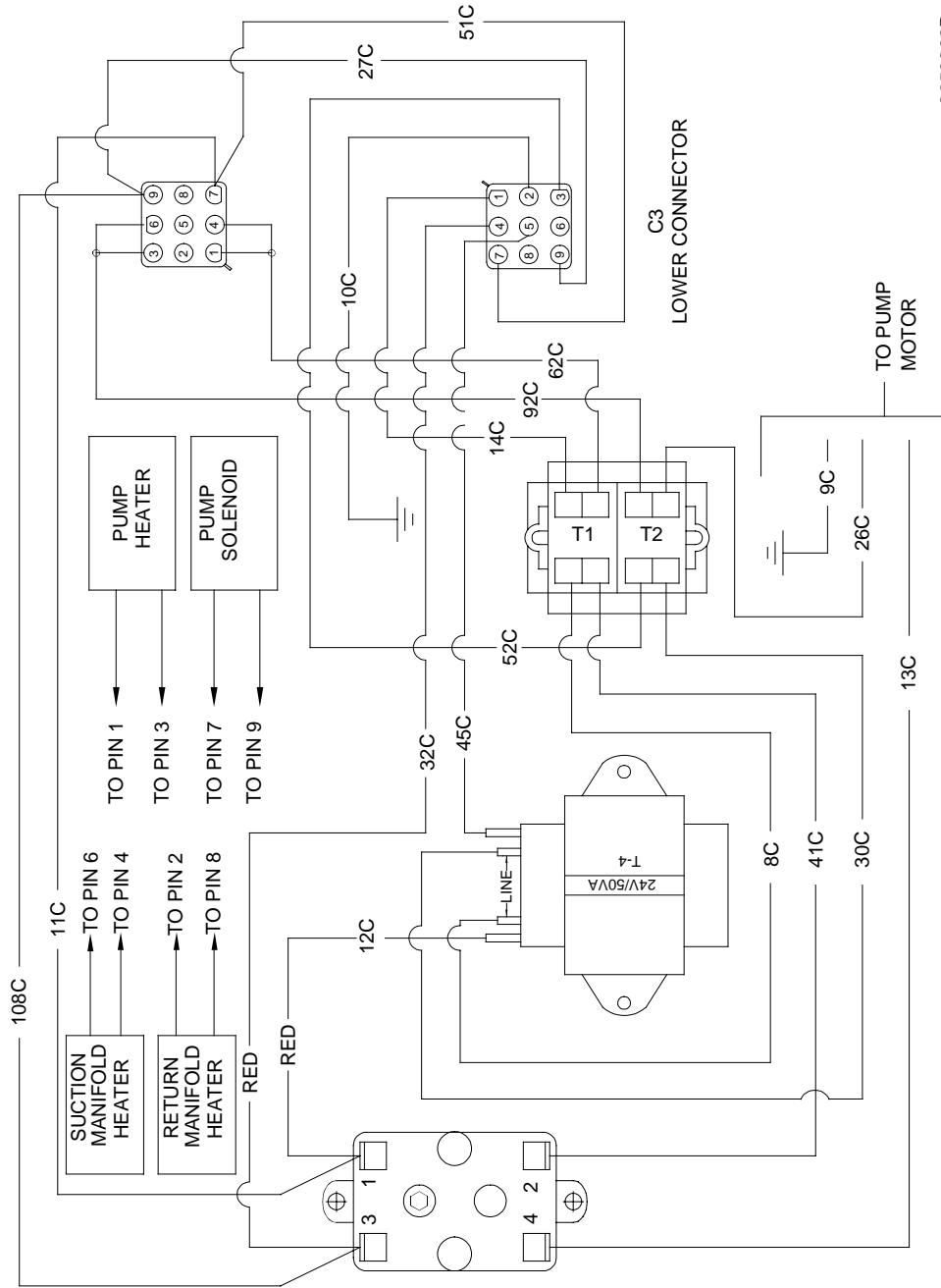

8050902D

MH152 Transformer Wiring Diagram (U.S. and Non-CE Export)

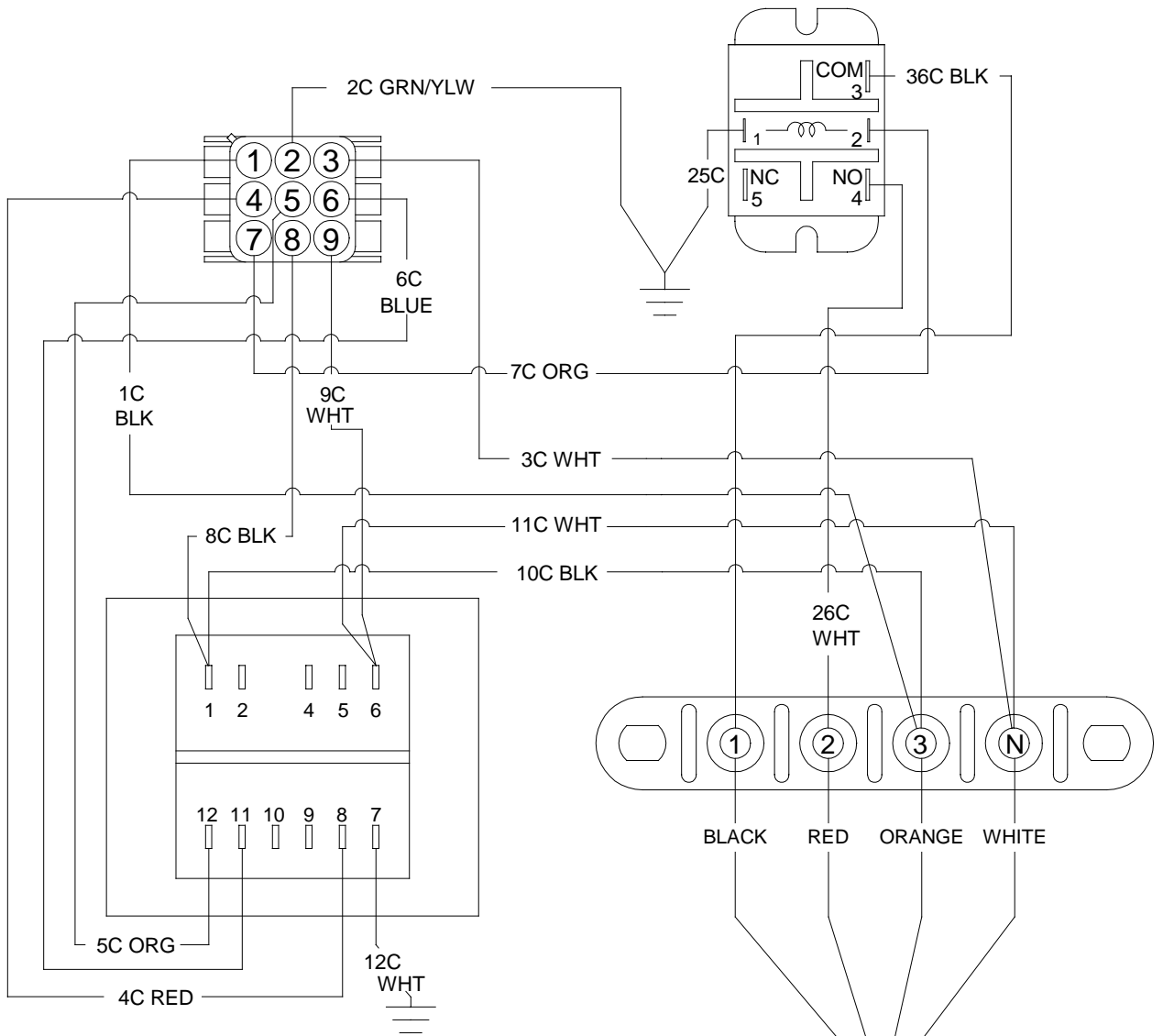

NOTE: USE TERMINALS 7 AND 8 FOR 24V OUTPUT.
USE TERMINALS 11 AND 12 FOR 12V OUTPUT.

120V CONFIGURATION SHOWN

VOLTS	COM	LINE
100	1	4
120	1	6
208	1	2
220	1	4
230	1	5
240	1	6

8050504C

MH152 Transformer Wiring Diagram (CE)

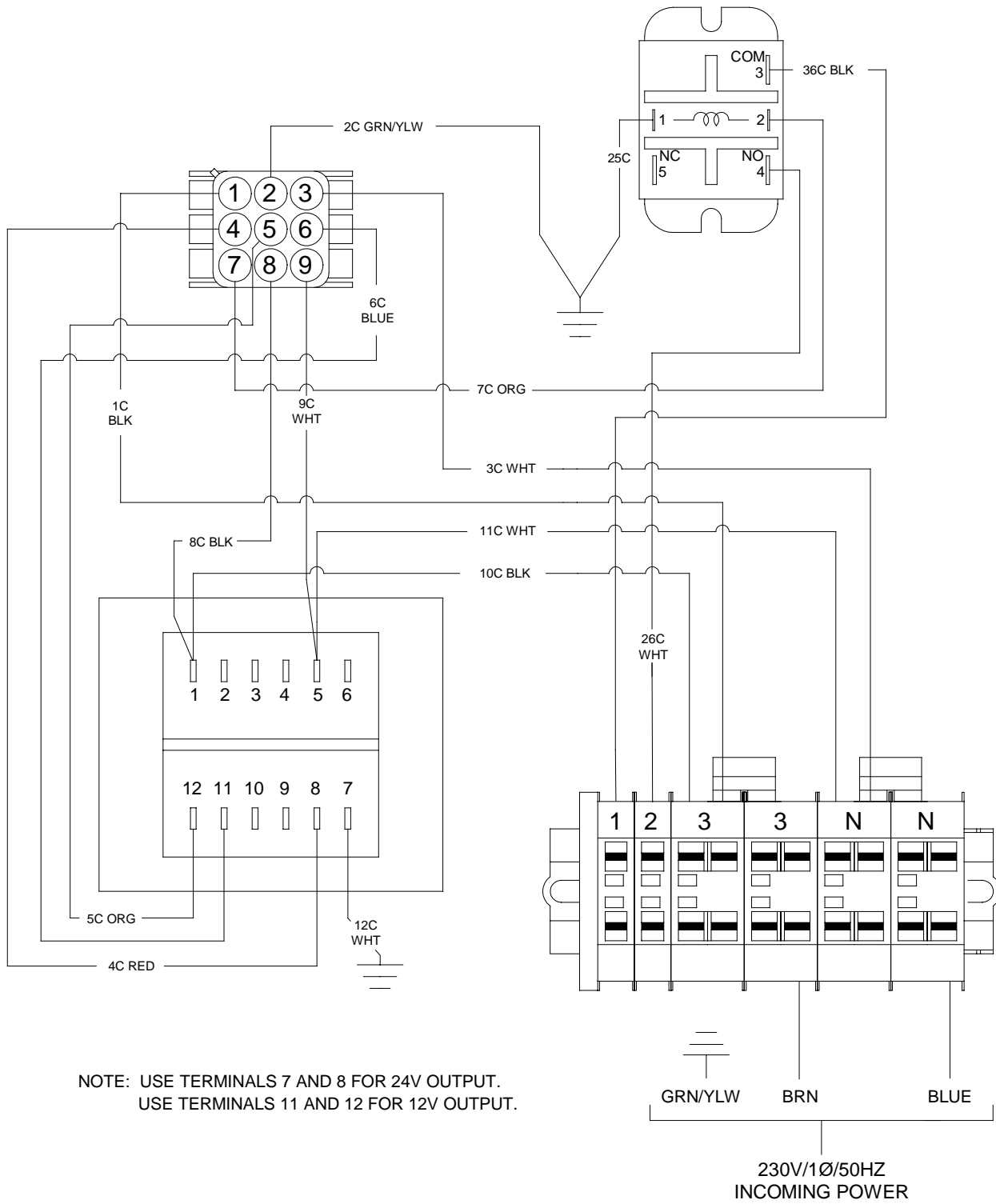

8050529B

BIH252/MH252 Transformer Box Wiring Diagram (U.S. and Non-CE Export)

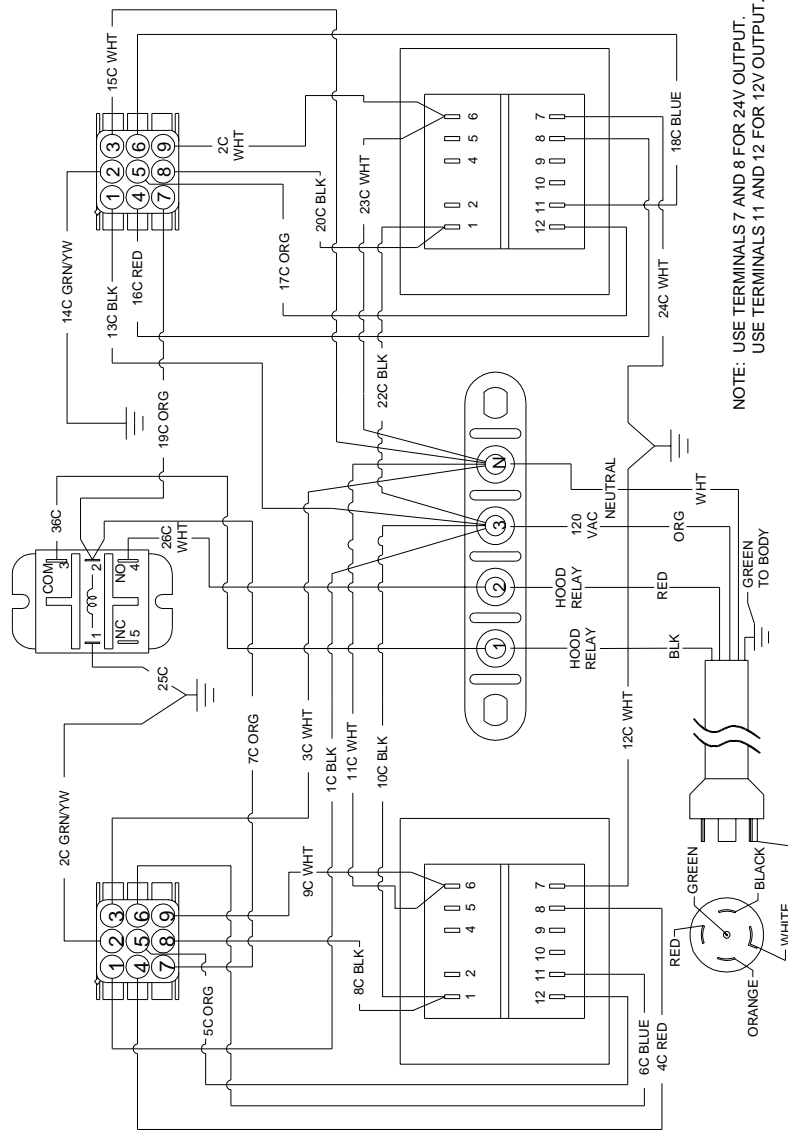

NOTE: USE TERMINALS 7 AND 8 FOR 24V OUTPUT.
USE TERMINALS 11 AND 12 FOR 12V OUTPUT.

CAUTION: THIS PLUG IS NOT BEING USED IN ITS
STANDARD 5-WIRE 120/208V NEMA L21-20P
CONFIGURATION. DO NOT CONNECT TO A STANDARD
120/208V 5-WIRE POWER SUPPLY.

120V CONFIGURATION SHOWN

VOLTS	COM	LINE
100	1	4
120	1	6
208	1	2
220	1	4
230	1	5
240	1	6

8050498D

BIH352/MH352 Transformer Box Wiring Diagram (U.S. and Non-CE Export)

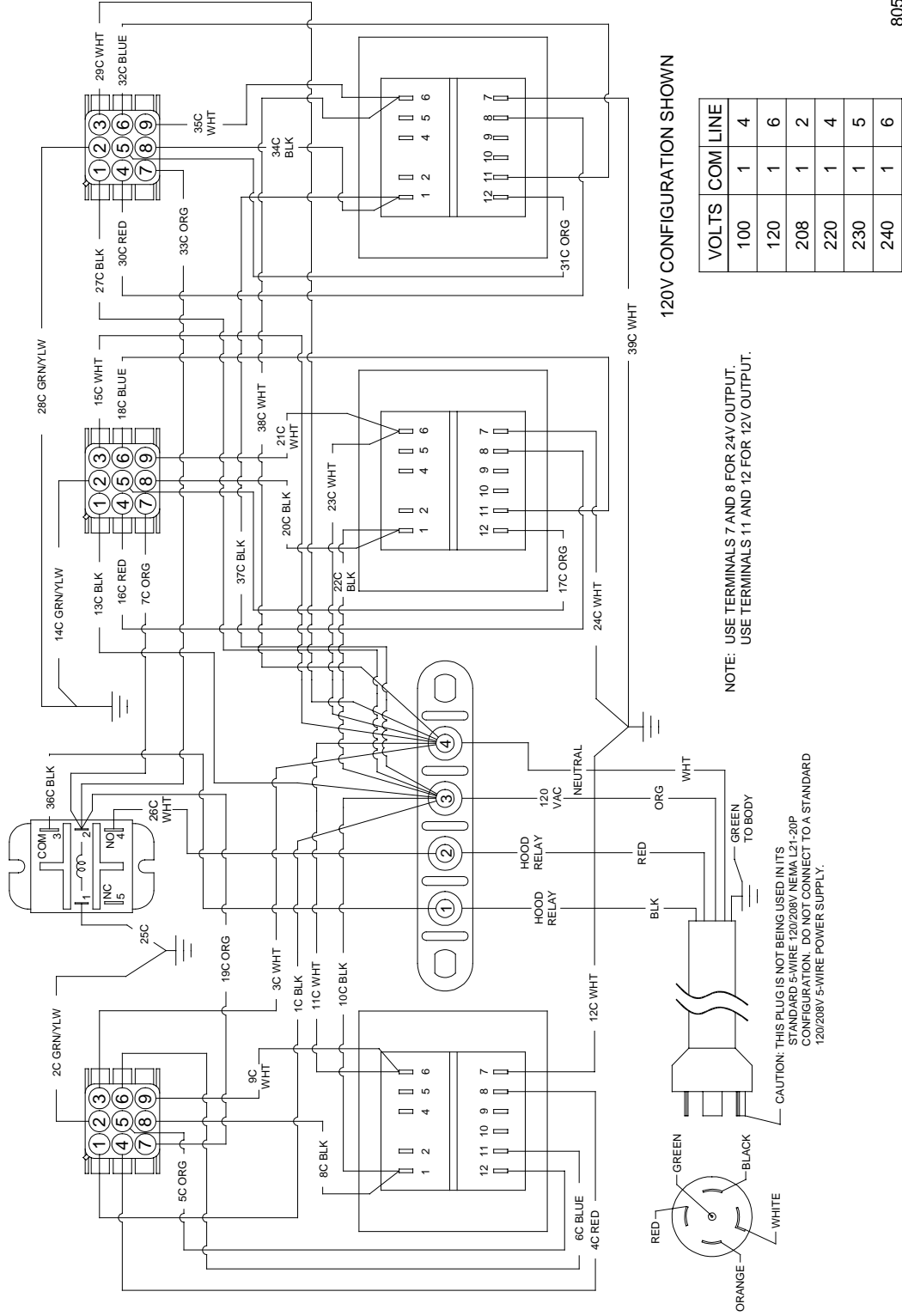

120V CONFIGURATION SHOWN

VOLTS	COM	LINE
100	1	4
120	1	6
208	1	2
220	1	4
230	1	5
240	1	6

8050499F

BIH452/MH452 Transformer Box Wiring Diagram (U.S. and Non-CE Export)

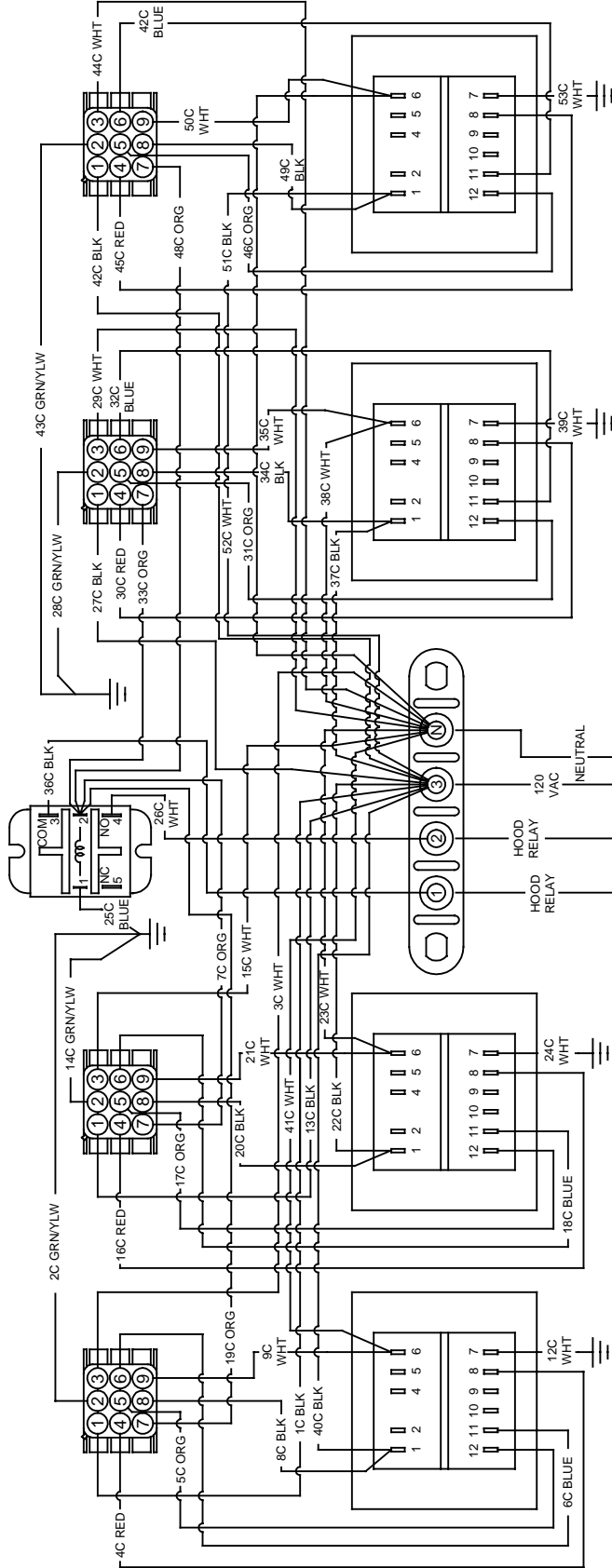

120V CONFIGURATION SHOWN

VOLTS	COM	LINE
100	1	4
120	1	6
208	1	2
220	1	4
230	1	5
240	1	6

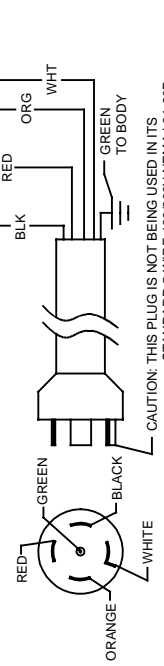

CAUTION: THIS PLUG IS NOT BEING USED IN ITS STANDARD 5-WIRE 120/208V NEMA L21-20P CONFIGURATION. DO NOT CONNECT TO A STANDARD 120/208V 5-WIRE POWER SUPPLY.

NOTE: USE TERMINALS 7 AND 8 FOR 24V OUTPUT. USE TERMINALS 11 AND 12 FOR 12V OUTPUT.

8050500E

BIH452/MH452 Transformer Box Wiring Diagram (CE)

NOTE: Also used for CE BIH252/MH252 and CE BIH352/MH352 Transformer Boxes.

NOTE: USE TERMINALS 7 AND 8 FOR 24V OUTPUT.
USE TERMINALS 11 AND 12 FOR 12V OUTPUT.

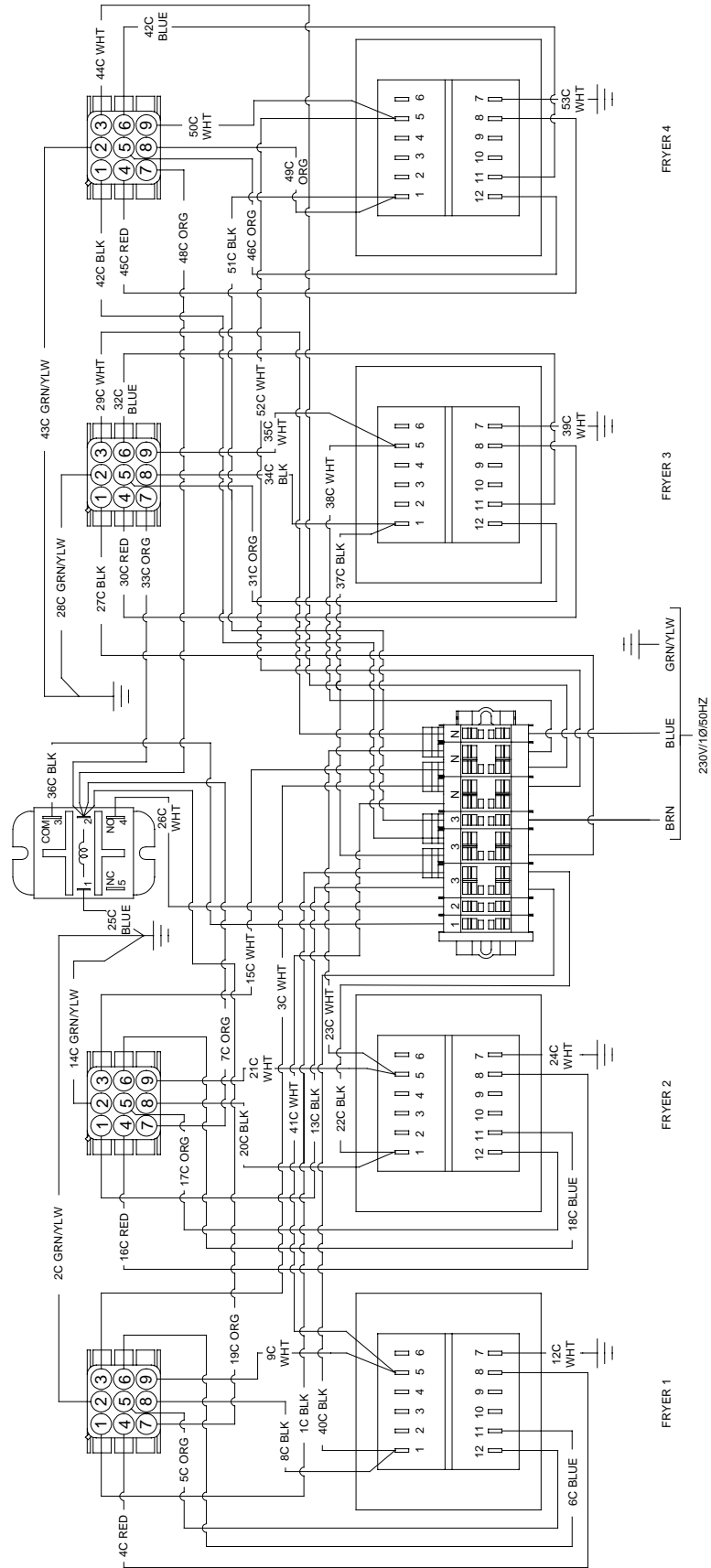

8050530D

CHAPTER 4: PARTS LIST

4.1 Accessories

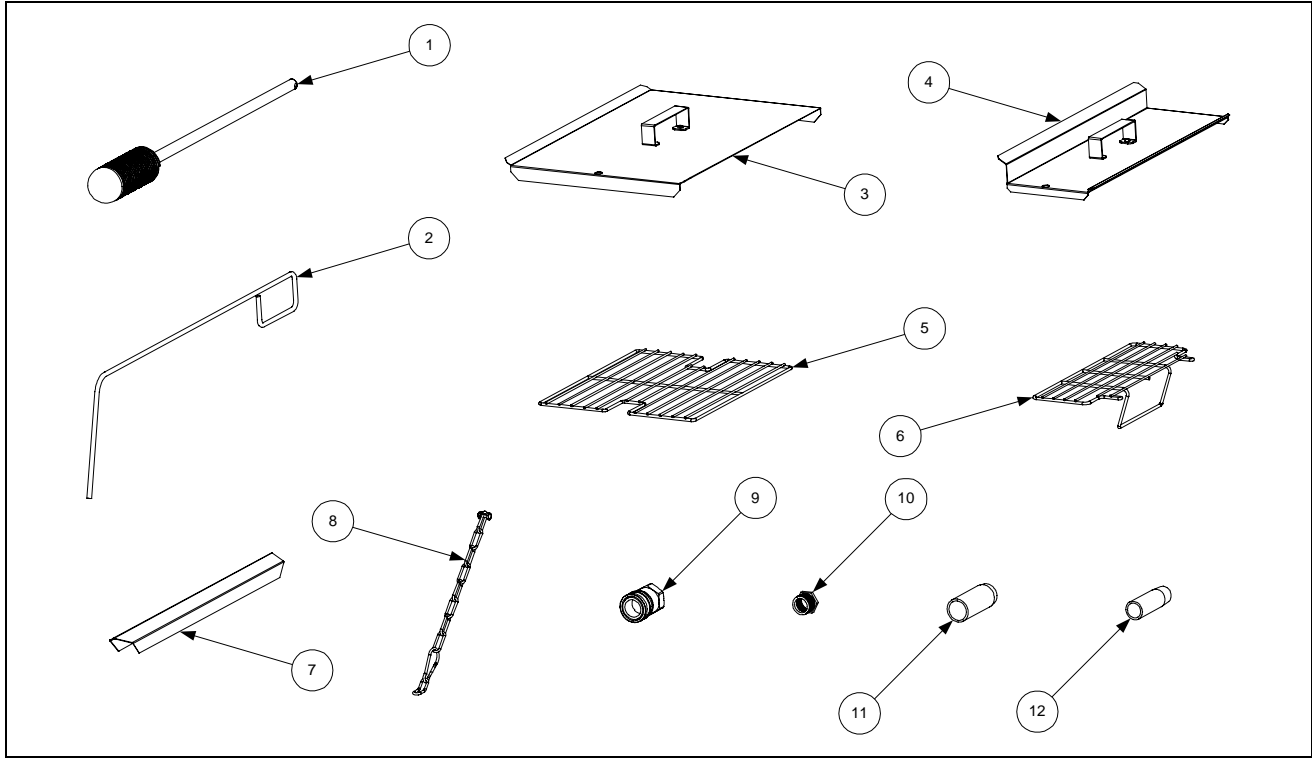

ITEM	PART #	COMPONENT
1	803-0209	Brush, Frypot Cleaning
2	803-0197	Fryer's Friend 27" (Clean-out Rod)
3	806-3068	Cover, Full-Vat Frypot
4	806-3407	Cover, Dual-Vat Frypot
*	826-0993SP	Kit, Replacement Cover Handle
5	803-0132	Rack, Full-Vat Basket Support
6	803-0133	Rack, Dual-Vat Basket Support
8	826-0900	Kit, Chain Restraint
7	910-7443	Top Connecting Strip
9		Coupling, Gas Line Female Quick-Disconnect
	810-0070	¾-inch
	810-0073	1-inch
*	810-0478	Gas Line, Flexible, with Cut-Off Valve
10	813-0032	Bushing, Flexible Gas Line
11	812-1378	Drain Extension, Non-Filter Full Vat Fryer
12	812-1374	Drain Extension, Non-Filter Dual Vat Fryer
*	803-0271	Basket, Twin
*	826-1157	Kit, Fuse and Fuse Puller
*	803-0002	Powder, Filter – Approximately 100 Cups
*	803-0046	Cup, Plastic Filter Powder Measuring
*	803-0170	Filter Pack – 100 Sheets

* Not illustrated.

4.2 Cabinetry Components

4.2.1 BIH152 and MH152 Cabinet Components

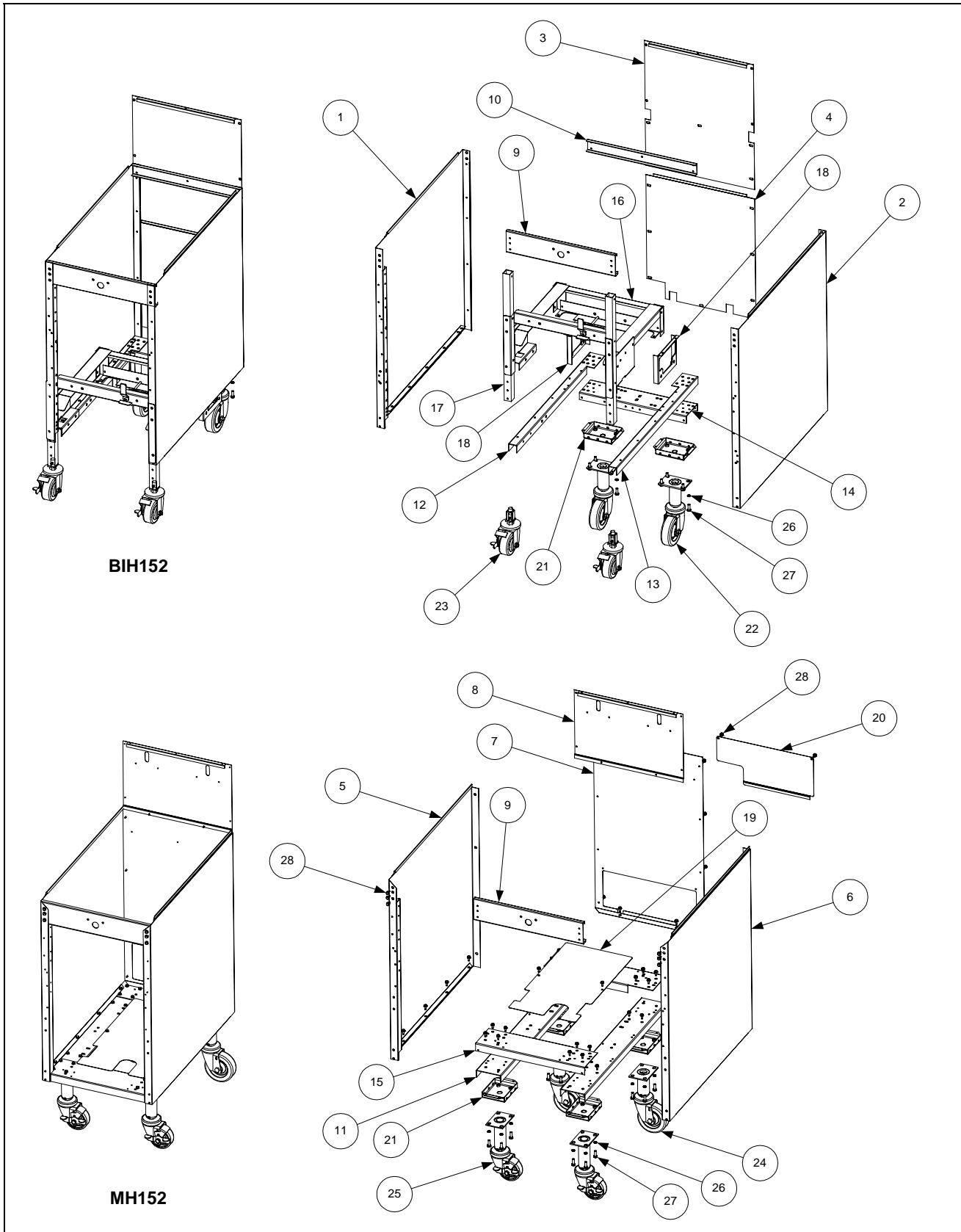

4.2.1 BIH152 and MH152 Cabinet Components cont.

ITEM	PART #	COMPONENT
1	911-7688SP	Side, BIH52 Left
2	912-7688SP	Side, BIH52 Right
3	900-5521	Back, BIH152 Upper
4	900-5670	Back, BIH152 Lower
5		Side, MH52 Left
	911-7036SP	Before 6 Nov 2000
	911-7688SP	After 5 Nov 2000
6		Side, MH52 Right
	912-7036SP	Before 6 Nov 2000
	912-7688SP	After 5 Nov 2000
7		Back, MH152 Lower
	900-2654	Before 6 Nov 2000
	900-5670	After 5 Nov 2000
8		Back, MH152 Upper
	900-2410	Before 6 Nov 2000
	900-5521	After 5 Nov 2000
9	900-4180	Brace, BIH152/MH152 Top
10	900-5519	Brace, BIH152 Rear (and MH152 after 5 Nov 2000)
11		Channel, MH52 Cabinet Base Left and Right Side
	900-7035	Before 6 Nov 2000
	900-7687	After 5 Nov 2000
12	901-5526	Channel, BIH152 Base Left Side
13	902-5526	Channel, BIH152 Base Right Side
14	900-4389	Channel, BIH152 Base Rear
15	900-4179	Channel, MH152 Cabinet Base Front and Rear
16	806-8421	Rail Assembly, BIH152
17	910-5656	Leg, BIH152 Front
18	823-2579	Bracket, BIH152 Filter Motor Mount
19		Shield, MH152 Base
	900-2541	Before 6 Nov 2000
	200-0075	After 5 Nov 2000
20	900-2649	Cover, MH52 Rear Access (notch on right)
21	806-5209	Leg Pad Assembly
22	812-1326	Caster, BIH152 Rear
23	823-2844	Caster, BIH152 Front (on units built prior to Nov 2000, use 823-2582)
*	810-1414	Insert, BIH152 Square Leg (component of Item 23, adapts caster to leg)
24	810-0327	Caster, Rear (without brake)
25		Caster, Adjustable Front (with brake)
	810-0326	Before 6 Nov 2000
	810-0944	After 5 Nov 2000
26	809-0191	Washer, ¼-inch Lock
27	826-1389	Screw, ¼-20 x ¾-inch Hex Head (Pkg. of 10)
28	826-1374	Screw, #10 x ¾-inch Washer Hex Head (cabinet screw) (Pkg. of 25)

* Not illustrated.

4.2.2 BIH52 Cabinet Components (Batteries)

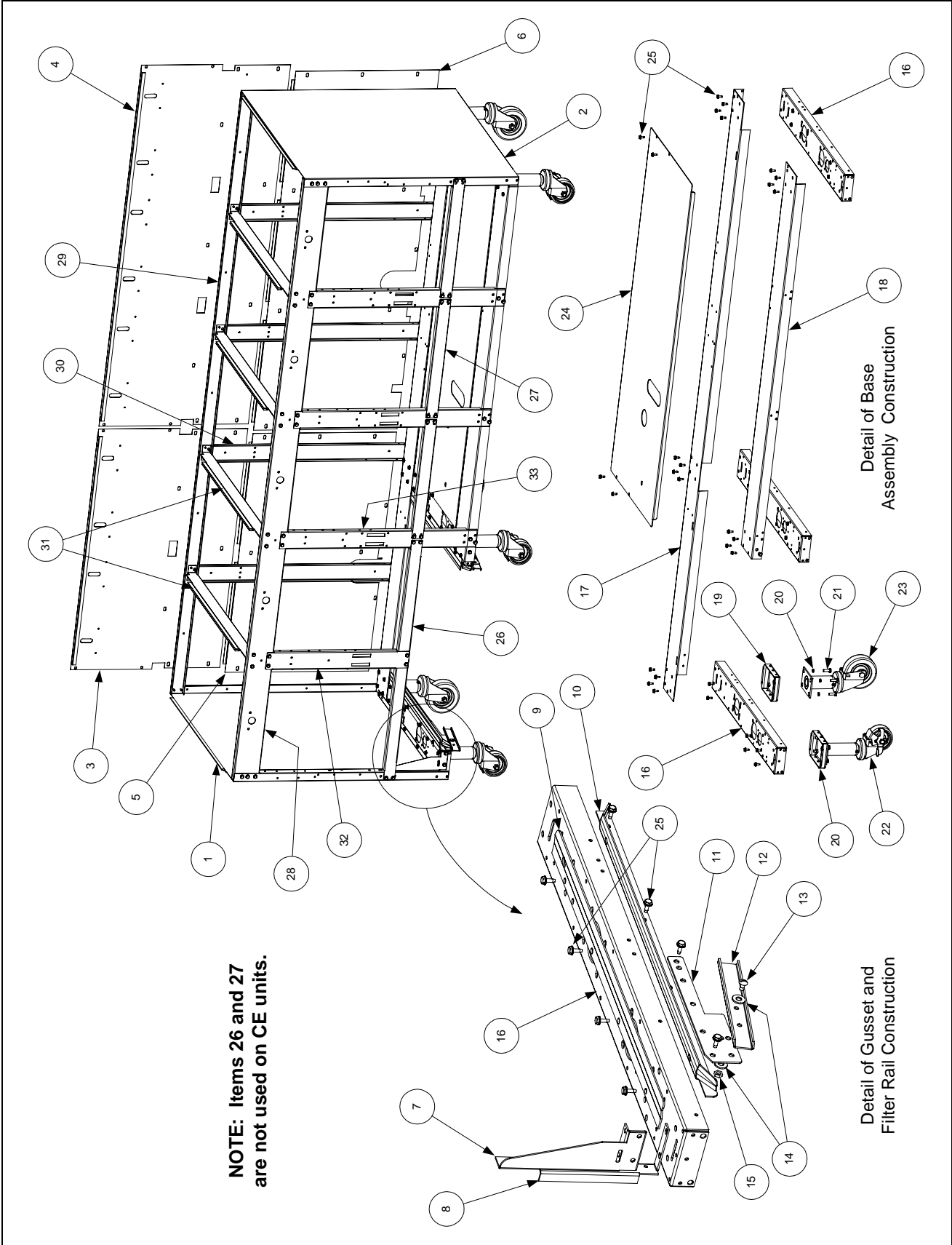

4.2.2 BIH152 Cabinet Components (Batteries) cont.

ITEM	PART #	COMPONENT
1	911-7688SP	Side, Left Cabinet (all models)
2	912-7688SP	Side, Right Cabinet (all models)
3	900-7714	Back, Upper Cabinet (BIH252, BIH452 & BIH552)(900-2881 BIMH452)
4	900-9424	Back, Upper Cabinet (BIH352 and BIH552)
5	900-7712	Back, Lower Cabinet (BIH252, BIH452 and BIH552)
6	900-9425	Back, Lower Cabinet (BIH352 and BIH552)
7	901-1810	Gusset, Left Cabinet (all models)
*	902-1810	Gusset, Right Cabinet (BIH252)
8	901-1948	Channel, Universal Side Support (all models)
9	911-4690	Rail, Left Top Filter (all models)
*	912-4690	Rail, Right Top Filter (all models)
10	910-5244	Rail, Universal Filter (all models)
11	900-1959	Bracket, Filter Lock Mounting (all models)
12	900-1957	Lock, Filter (all models)
13	809-0422	Screw, 10-32 x .4-inch Shoulder (all models)
14	809-0189	Washer, ¼-inch SS Flat
15	809-0053	Nut, 10-32 Hex
16	900-7687	Channel, Side Base (all models)
17		Channel, Rear Base
	900-7686	BIH252
	900-9420	BIH352
	900-2390	BIH452
	900-9555	BIH552
18		Channel, Front Base
	900-4787	BIH352
	900-2389	BIH452
	9009556	BIH552
19	806-5209	Leg Pad Assembly (all models)
20	809-0191	Washer, ¼-inch Lock (all models)
21	826-1389	Screw, ¼-20 x ¾-inch Hex Head (all models) (Pkg. of 10)
22	810-0944	Caster with Brake, Front (all models)
23	810-0327	Caster, Rear (all models)
24		Shield
	900-2452	BIH352
	900-2453	BIH452
	900-9601	BIH552
25	826-1374	Screw, #10 x ½-inch Hex Washer Head (cabinet screw)(Pkg. of 25)
26	900-4798	Support, Long Cross (all models – not used on CE units)
27	900-2562	Support, Short Cross (all models – not used on CE units)
28		Brace, Top Front
	900-7033	BIH252
	900-9248	BIH352
	900-2393	BIH452
	900-9558	BIH552
29		Brace, Top Rear
	900-7708	BIH252
	900-7709	BIH352

* Not illustrated.

LIST CONTINUED ON NEXT PAGE

4.2.2 BIH52 Cabinet Components (Batteries) cont.

ITEM	PART #	COMPONENT
	900-2391	BIH452
	900-9557	BIH552
30	900-7710	Post, Cabinet (all models)
31	900-7358	Divider, Cabinet (all models)
32		Post, Short Door
	900-4797	All non-CE models.
	900-2437	All CE models.
33	900-4799	Post, Long Door (BIH352, BIH452 and BIH552)
*	809-0413	Spacer, Door Post (1/4-inch ID x 4mm nylon washer)

* Not illustrated.

4.2.3 MH52 Cabinet Components (Batteries)

NOTE: MH52 cabinetry was standardized with BIH52 cabinetry beginning with units manufactured 6 November 2000 and later. All MH52 cabinetry components except base assembly parts on units manufactured after 6 November 2000 are the same as those on BIH52 units of the same size.

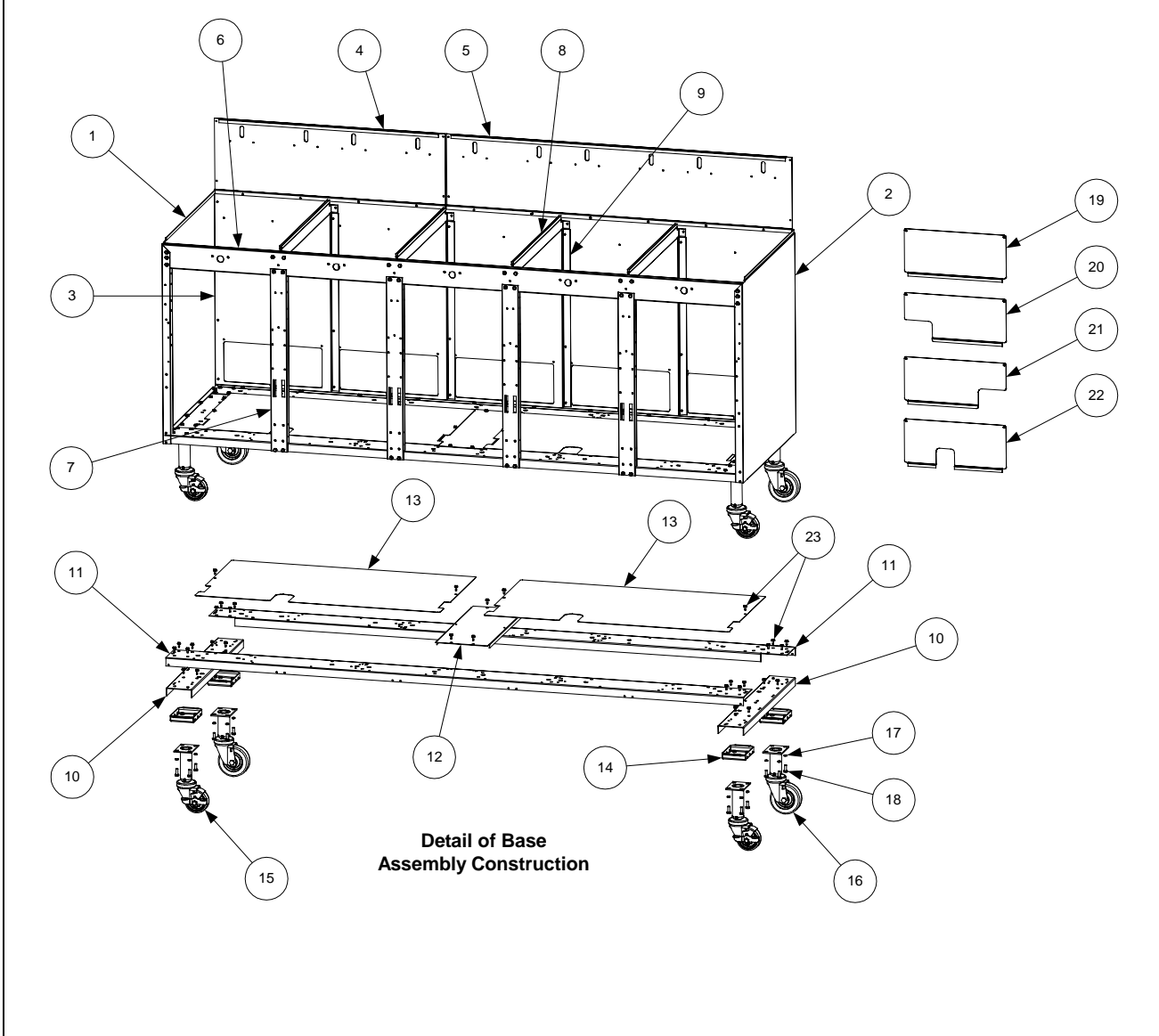

4.2.3 MH52 Cabinet Components (Batteries) cont.

ITEM	PART #	COMPONENT
1		Side, Left Cabinet (all models)
	911-7036SP	Before 6 Nov 2000
	911-7688SP	After 5 Nov 2000
2		Side, Right Cabinet (all models)
	912-7036SP	Before 6 Nov 2000
	912-7688SP	After 5 Nov 2000
3		Back, Lower Cabinet
		Before 6 Nov 2000
	900-2652	MH252
	900-2651	MH352
	900-4915	MH452
	900-9600	MH552
		After 5 Nov 2000
	900-7712	MH252, MH452, and MH552 (18-inches x 31-inches)
	900-9425	MH352 and MH552 (18-inches x 46.5-inches)
4		Back, Upper Cabinet, MH252 and MH552
	900-2411	Before 6 Nov 2000 (10.2-inches x 31.1-inches)
	900-7714	After 5 Nov 2000 (18.72-inches x 31.24-inches)
5		Back, Upper Cabinet, MH352 and MH552
	900-2412	Before 6 Nov 2000 (10.2-inches x 46.6-inches)
	900-9424	After 5 Nov 2000 (18.72-inches x 46.88-inches)
*		Back, Upper Cabinet, MH452
	900-2413	Before 6 Nov 2000 (9.66-inches x 62.36-inches)
	900-7714	After 5 Nov 2000 (18.72-inches x 31.24-inches)
6		Brace, Top Front
	900-7033	MH252
	900-9248	MH352
	900-2393	MH452
	900-9558	MH552
*		Brace, Top Rear (used only on units built after 05 Nov 2000)
	900-7708	MH252
	900-7709	MH352
	900-2391	MH452
	900-9557	MH552
7		Post, Door (all models)
	900-7032	Before 6 Nov 2000
	900-4799	After 5 Nov 2000
*	809-0413	Spacer, Door Post (1/4-inch ID x 4mm nylon washer)
8		Divider, Cabinet (all models)
	900-7356	Before 6 Nov 2000
	900-7358	After 5 Nov 2000
9		Brace, Back Support (all models)
	900-7053	Before 6 Nov 2000
	900-7710	After 5 Nov 2000
10		Channel, Cabinet Base Left and Right Side (all models)
	900-7035	Before 6 Nov 2000
	900-7687	After 5 Nov 2000

* Not illustrated.

LIST CONTINUED ON NEXT PAGE

4.2.3 MH52 Cabinet Components (Batteries) cont.

ITEM	PART #	COMPONENT
11		Channel, Cabinet Base Front and Rear
		MH252
	900-7034	Before 6 Nov 2000
	900-7686	After 5 Nov 2000
		MH352
	900-9249	Before 6 Nov 2000
	900-9420	After 5 Nov 2000
		MH452
	900-4906	Before 6 Nov 2000
	900-2390	After 5 Nov 2000
		MH552
	900-9611	Before 6 Nov 2000
	900-9555	After 5 Nov 2000
12		Support, Center Base (MH452, MH552)
	900-4907	Before 6 Nov 2000
	200-0769	After 5 Nov 2000
13		Shield, Cabinet Base
		MH252, MH452
	900-2527	Before 6 Nov 2000 (18-inches x 25.2-inches) (MH452 uses 2)
	200-0772	After 5 Nov 2000 (17.75-inches x 25.06-inches) (MH452 uses 2)
		MH352
	900-2528	Before 6 Nov 2000 (18-inches x 17.5-inches) plus 900-2527
	200-0771	After 5 Nov 2000 (17.75-inches x 40.7-inches)
		MH552
	900-9623	Before 6 Nov 2000 (18-inches x 33-inches)
		After 5 Nov 2000 uses 1 each of 200-0771 and 200-0772
14	806-5209	Leg Pad Assembly (all models)
15	810-0944	Caster with Brake, Front (all models)
16	810-0327	Caster, Rear (all models)
17	809-0191	Washer, ¼-inch Lock (all models)
18	826-1389	Screw, ¼-20 x ¾-inch Hex Head (all models) (Pkg. of 10)
19	900-2648	Cover, MH52 Rear Access (no notch)
20	900-2649	Cover, MH52 Rear Access (notch on right corner when viewed from rear)
21	900-2650	Cover, MH52 Rear Access (notch on left corner when viewed from rear)
22	900-5482	Cover, MH52 Rear Access (notch in center)
23	826-1374	Screw, #10 x ½-inch Hex Washer Head (cabinet screw) (Pkg. of 25)

* Not illustrated.

THIS PAGE INTENTIONALLY LEFT BLANK

4.2.4 BIH52/MH52 Cap-N-Splash Assemblies, Fluecaps, Standoffs and Related Parts

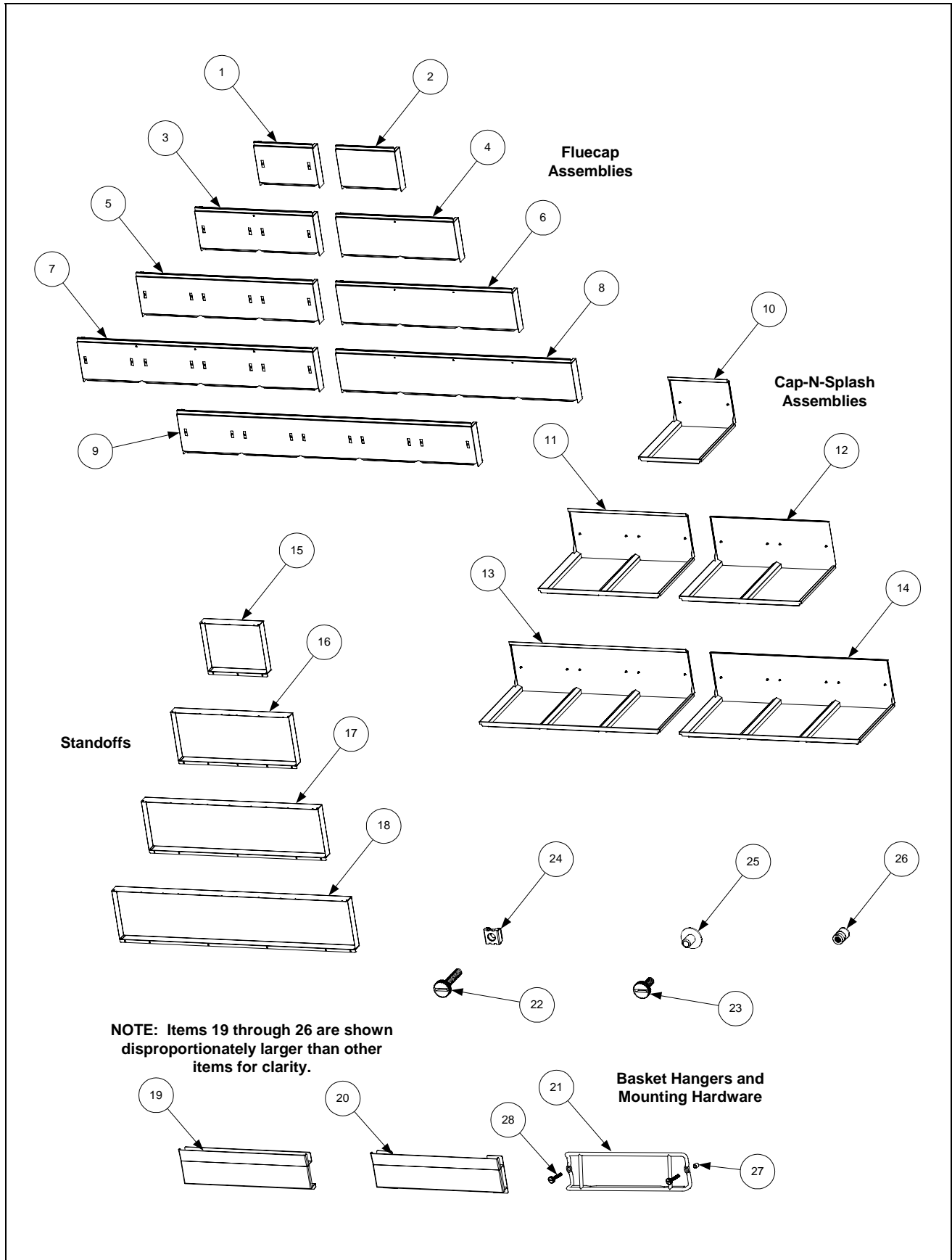

ITEM	PART #	COMPONENT
		Fluecap Assemblies
1	910-2414	BIH152/MH152 (standard)
2	900-7921	BIH152/MH152 (for units with Cap-N-Splash)
3	823-2544	BIH252/MH252 (standard)
4	900-7926	BIH252/MH252 (for units with Cap-N-Splash)
5	823-2545	BIH352/MH352 (standard)
6	900-7927	BIH352/MH352 (for units with Cap-N-Splash)
7	823-2546	BIH452/MH452 (standard)
8	900-7928	BIH452/MH452 (for units with Cap-N-Splash)
9	823-2887	BIH552/MH552 (standard)
*	900-2447	Flue Clip Support
	Old	Cap-N-Splash Assemblies (See Note)
10	823-2276	BIH152/MH152 (<i>New 823-3066</i>) Kit 826-1223
11	823-2277	BIH252/MH252 (<i>New 823-3067</i>) Kit 826-1218
12	823-2833	JBH252 (Japanese units)
13	823-2278	BIH352/MH352 (<i>New 823-3068</i>) Kit 826-1217
14	823-2879	JBH352 (Japanese units)
*	823-2279	BIH452 (<i>New 823-3070</i>) Kit 826-1216
*	-----	BIH552 (<i>New 823-3069</i>)
		Standoffs
15	900-2406	BIH152/MH152
16	900-2407	BIH252/MH252
17	900-2408	BIH352/MH352
18	900-2409	BIH452/MH452
*	200-6556	BIH552/MH552
		Basket Hangers and Mounting Hardware
19	823-0782	Solid (old design)
20	823-1618	Solid (new design) for drop in probes
21	810-2793	Wire Form (with .330-inch mounting holes)
22	809-0171	Thumbscrew, 1/4-20 x 1 3/8-inch
23	809-0402	Thumbscrew, 1/4-20 x 1/2-inch
24	826-1351	Nutsert, 1/4-20 Square (for use on standard fluecap) (Pkg. of 10)
25	809-0535	T-Nut, 1/4-20 x 7/16-inch (for use on Cap-N-Splash assembly)
26	809-0079	Nutsert, 1/4-20 Round (for use on early-production Cap-N-Splash)
27	809-0921	Spacer, Basket Hanger
28	809-0989	Thumbscrew, 1/4-20 x 1-inch

* Not illustrated.

NOTE: In August 2001, a design change required that all models above serial # 0108 replacing the Cap-N-Splash must also replace the topcap. The new topcap and Cap-N-Splash are not interchangeable with the previous one.

4.2.5 BIH52/MH52 Control Panel Frames and Topcaps

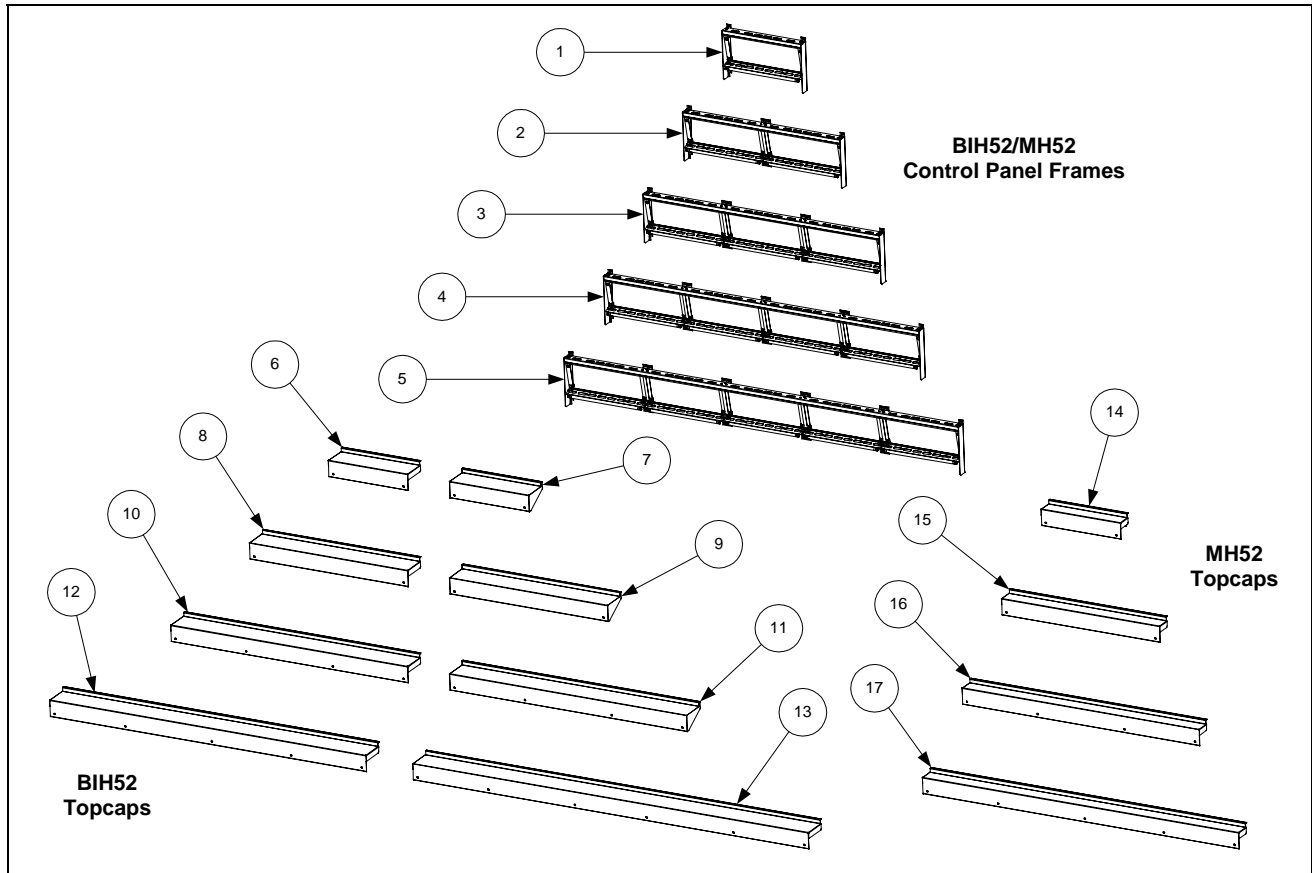

ITEM	PART #	COMPONENT
1	806-6137SP	BIH152/MH152 Control Panel Frame Assembly
2	806-4819SP	BIH252/MH252 Control Panel Frame Assembly
3	806-4820SP	BIH352/MH352 Control Panel Frame Assembly
4	806-5963SP	BIH452/MH452 Control Panel Frame Assembly
5	806-9750	BIH552/MH552 Control Panel Frame Assembly
	Older	Topcaps – See Note on previous page.
6	824-0641	BIH152 Topcap (<i>New 823-0873</i>) <i>w/out hole in front.</i>
7	823-2657	JBIH152 Topcap (Japanese units)
8	824-0544	BIH252 Topcap (<i>New 823-0874</i>) <i>w/out hole in front.</i>
9	823-2652	JBIH252 Topcap (Japanese units)
10	824-0543	BIH352 Topcap (<i>New 823-0875</i>) <i>w/out hole in front.</i>
11	823-2651	JBIH352 Topcap (Japanese units)
12	824-0545	BIH452 Topcap (<i>New 823-0876</i>) <i>w/out hole in front.</i>
13	824-0775	BIH552 Topcap (<i>New 823-0877</i>) <i>w/out hole in front.</i>
14	824-0641	MH152 Topcap
15	824-0544	MH252 Topcap
16	824-0543	MH352 Topcap
17	824-0545	MH452 Topcap

4.2.6 BIH52/MH52 Door Components

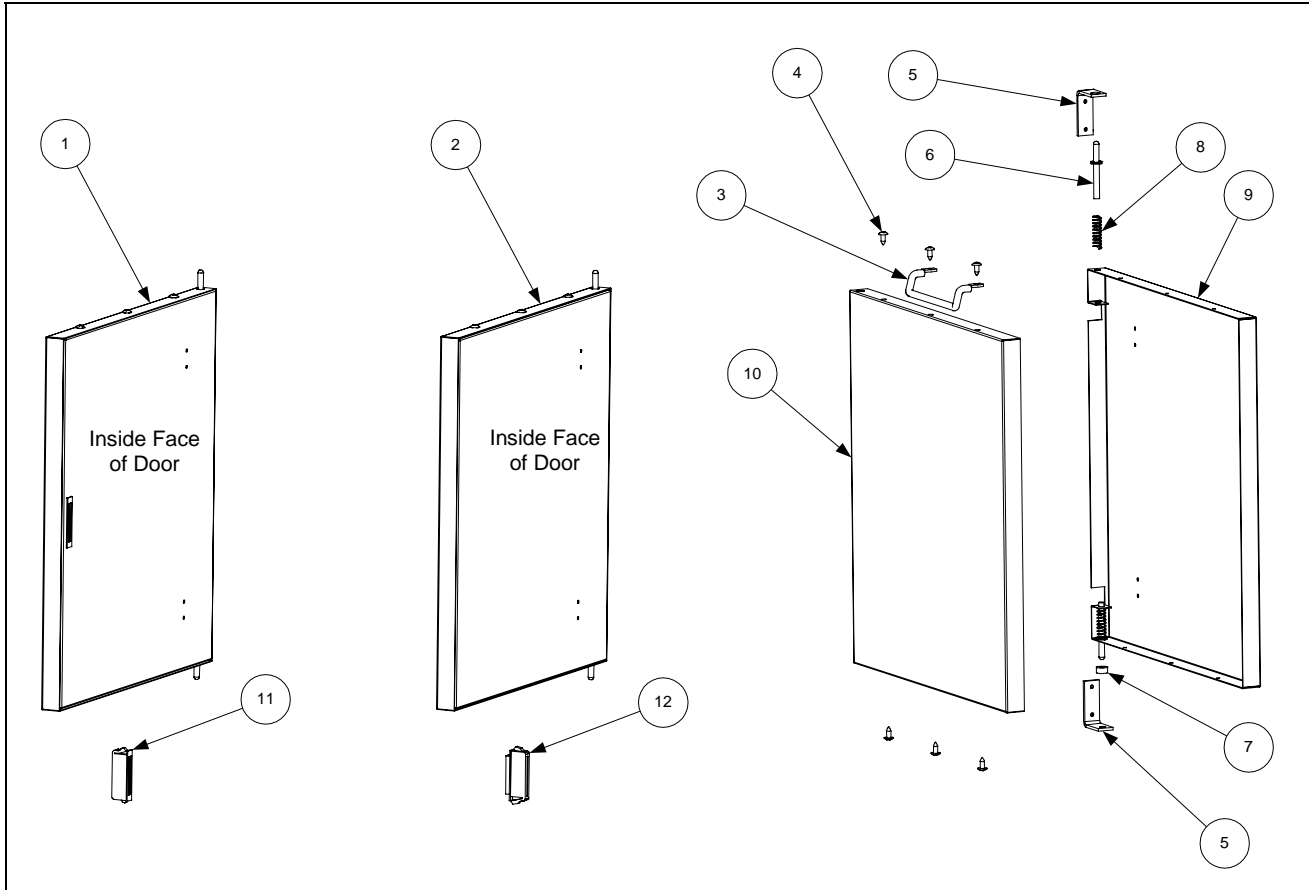

ITEM	PART #	COMPONENT
1	806-3057SP	Door Assembly with Magnet, BIH52/MH52 Complete
2	806-6545SP	Door Assembly without Magnet, BIH52/MH52 Complete
3	810-1422	Handle, Wireform Door
4	826-1379	Screw, #10 x ½-inch Phillips Truss Head (Pkg of 10)
5	810-1508	Hinge, Universal Door
*	826-1371	Screw, #8 x ½-inch Hex Head (Pkg of 25) (for attaching Item 5 to cabinet)
6	806-4487SP	Pin Assembly, Door Hinge
7	809-0193	Washer, ¼-inch Nylon Flat
8	826-1343	Spring, Door Hinge (Pkg. of 10)
9		Liner, Door
	900-2485	BIH52/MH52 Universal Door (no cutout for magnet)
	930-3667	BIH52/MH52 Door (with cutout for magnet)
10	824-0137	Panel, BIH52/MH52 Door
11	810-0066	Magnet (door-mounted, used with Item 1)
12	810-1105	Magnet (door post-mounted, used with Item 2)

* Not illustrated.

NOTE: Handle (Item 3), Hinge (Item 5), and Washer (Item 7) are not included in Door Assemblies (Items 1 and 2). These components must be ordered separately.

4.3 Combustion System, Frypot and Gas System Components

4.3.1 Blowers and Associated Parts

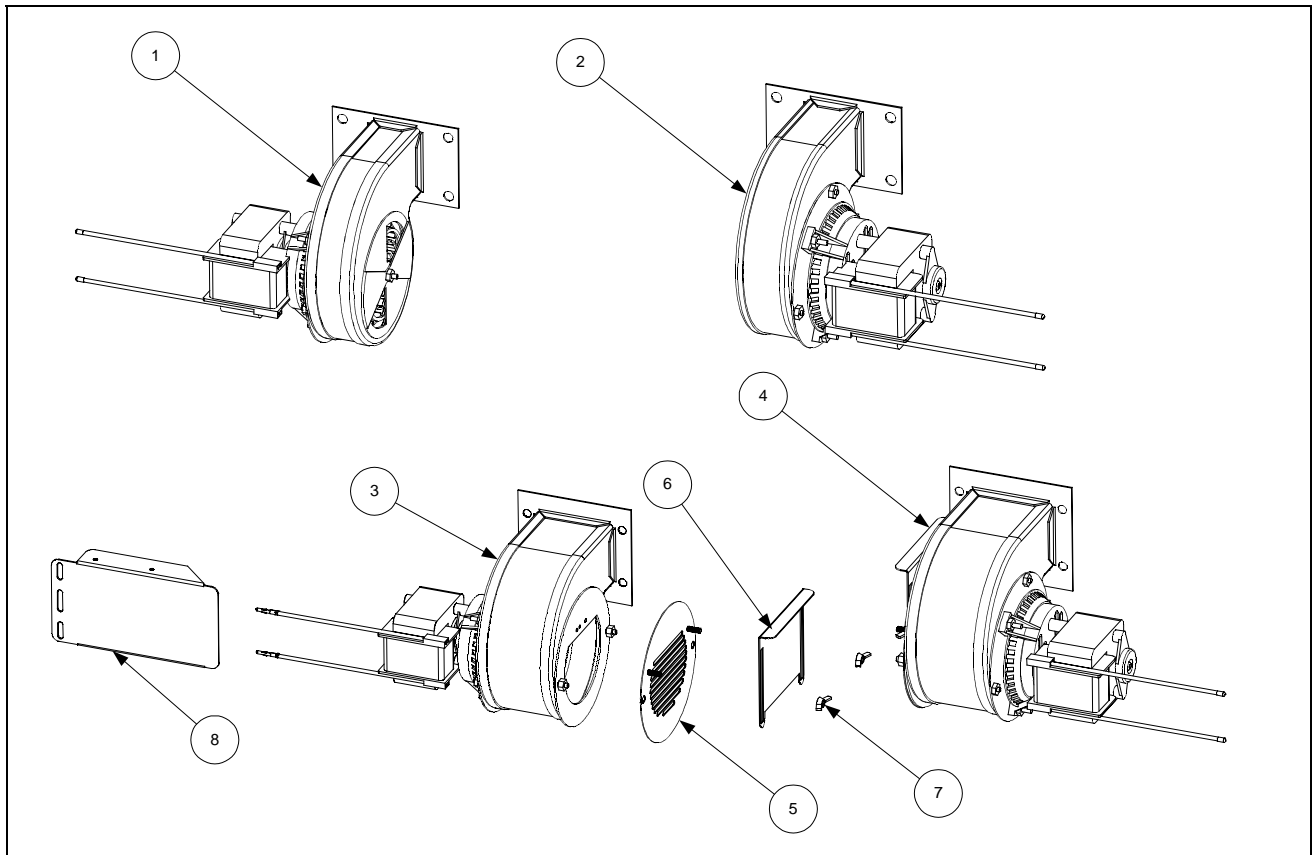

ITEM	PART #	COMPONENT
1		Blower, Left (with 1.54-inch (3.91 cm) narrow housing)
	106-2996SP	100V, 50/60 Hz
	106-2994SP	115V, 50/60 Hz
	806-5841SP	230V, 50 Hz
	106-2995SP	240V, 50/60 Hz
2		Blower, Right (with 1.54-inch (3.91 cm) narrow housing)
	806-4697SP	100V, 50/60 Hz
	106-2997SP	115V, 50/60 Hz
	806-7060SP	230V, 50 Hz
	106-2998SP	240V, 50/60 Hz
3	106-3000SP	Blower Assembly, Left 230V, 50/60 Hz (with 2.8-inch (7.11 cm) wide housing) CE and Non-CE
4	106-3001SP	Blower Assembly, Right 230V, 50/60 Hz (CE) (with 2.8-inch (7.11 cm) wide housing)
5	806-9689	Finger Guard/Air Flow Inhibitor Adapter (CE)
6	900-8699	Air Flow Inhibitor (CE)
7	826-1382	Wingnut, 8-32 (Pkg. of 10)
8	826-1426	Shield, MH52 Blower Motor
*	KIT-0155SP	High Altitude Blower Kit (required above 5000 Ft, 1525 M)

* Not illustrated.

NOTE: Items 5, 6, and 7 are components of Items 3 and 4. In CE units, they replace the rotating air shutter that is standard on 230V Blowers 106-3000SP and 106-3001SP (Items 3 and 4).

4.3.2 Ignition Sub-System Components

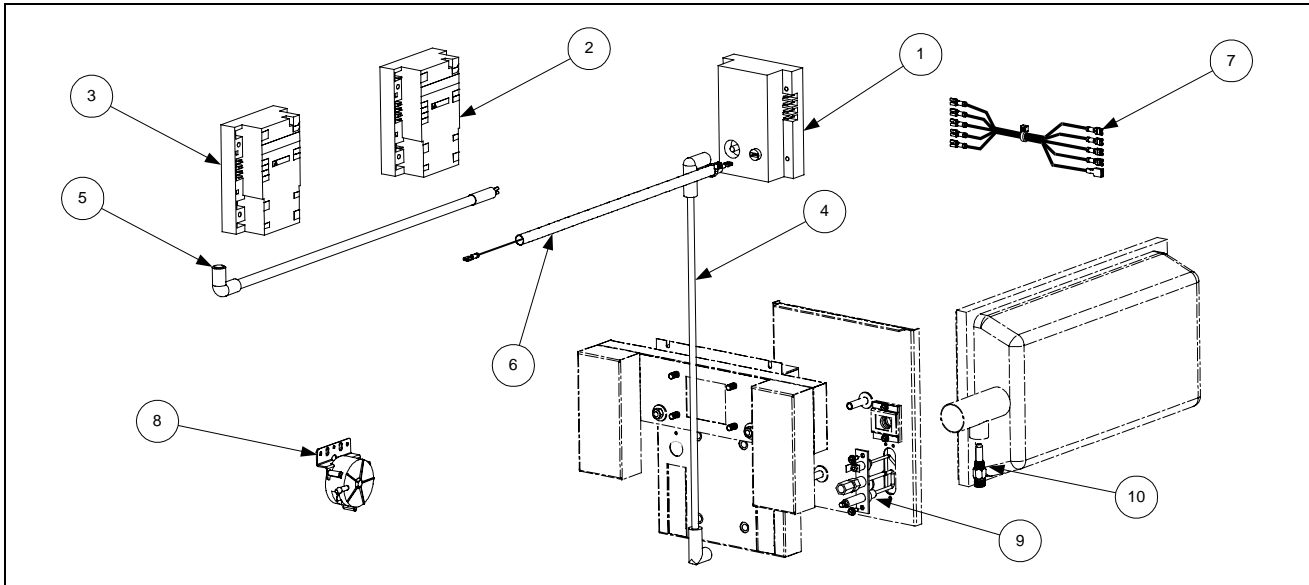

ITEM	PART #	COMPONENT
1	See Pg. 4-27	Ignition Module, Full and Dual Vat (original design, with fuse)
2	See Pg. 4-27	Ignition Module, Full Vat (new design, without fuse)
*	826-1346	Spacer (Pkg. of 10)
3	See Pg. 4-27	Ignition Module, Dual Vat (new design, without fuse)
4		Ignition Cable (with two 90° connectors, used with Item 1 only)
	807-1878	19-inches long
	807-1200	27-inches long
5	826-1721	Ignition Cable w/ Rajah (with 90° connector, use w/ Items 2 and 3)
	807-3483	Cable, H52 Ignition 21"
	807-3484	Connector, Rajah
6	806-6085SP	Wiring Assembly, Ignitor
7	806-6084SP	Wiring Assembly, Ignition Module
8	807-2263	Switch, Air Pressure (<i>use 807-2262 in units with 100VAC power supply</i>)
*	KIT1428	CE Export H52 Air Switch Kit
9		Ignitor and Gasket Kit (816-0059 Gasket Only)
	826-0981	Natural Gas (G20, G25)
	826-0982	Propane/Butane (G30, G31)
	826-1002	Manufactured Gas
10		Orifice
	810-1221	2.00 mm Propane/Butane (0-4999 Ft, 0-1524 M) (Japan)
	810-1325	2.05 mm Propane/Butane (G30, G31) (0-4999 Ft, 0-1524 M)
	810-0386	2.10 mm Propane/Butane (0-4999 Ft, 0-1524 M) Standard LP
	810-0413	2.16 mm Propane/Butane (G30, G31) (5000-6999 Ft, 1525-2133 M)
	812-1028	2.20 mm Propane/Butane (G30, G31) (7000-10,999 Ft, 2134-3352 M)
	812-1134	3.10 mm Natural Gas (G20, G25) (0-4999 Ft, 0-1524 M) (Japan)
	810-0403	3.40 mm Natural Gas (G20, G25) (0-4999 Ft, 0-1524 M) Standard Natural Gas
	810-0437	3.60 mm Natural Gas (G20, G25) (5000-6999 Ft, 1525-2133 M)
	812-1144	3.65 mm Natural Gas (G20, G25) (7000-8999 Ft, 2134-2743 M)
	812-1145	3.70 mm Natural Gas (G20, G25) (9000-10,999 Ft, 2744-3352 M)
	810-0642	5.95 mm Manufactured Gas (0-4999 Ft, 0-1524 M)
*	826-1196	Conversion Kit, Natural Gas (G20, G25) to Propane/Butane (G30, G31) CE
*	826-1197	Conversion Kit, Propane/Butane (G30, G31) to Natural Gas (G20, G25) CE

* Not illustrated.

4.3.3 Frypot Assembly Components

4.3.3.1 Full Vat

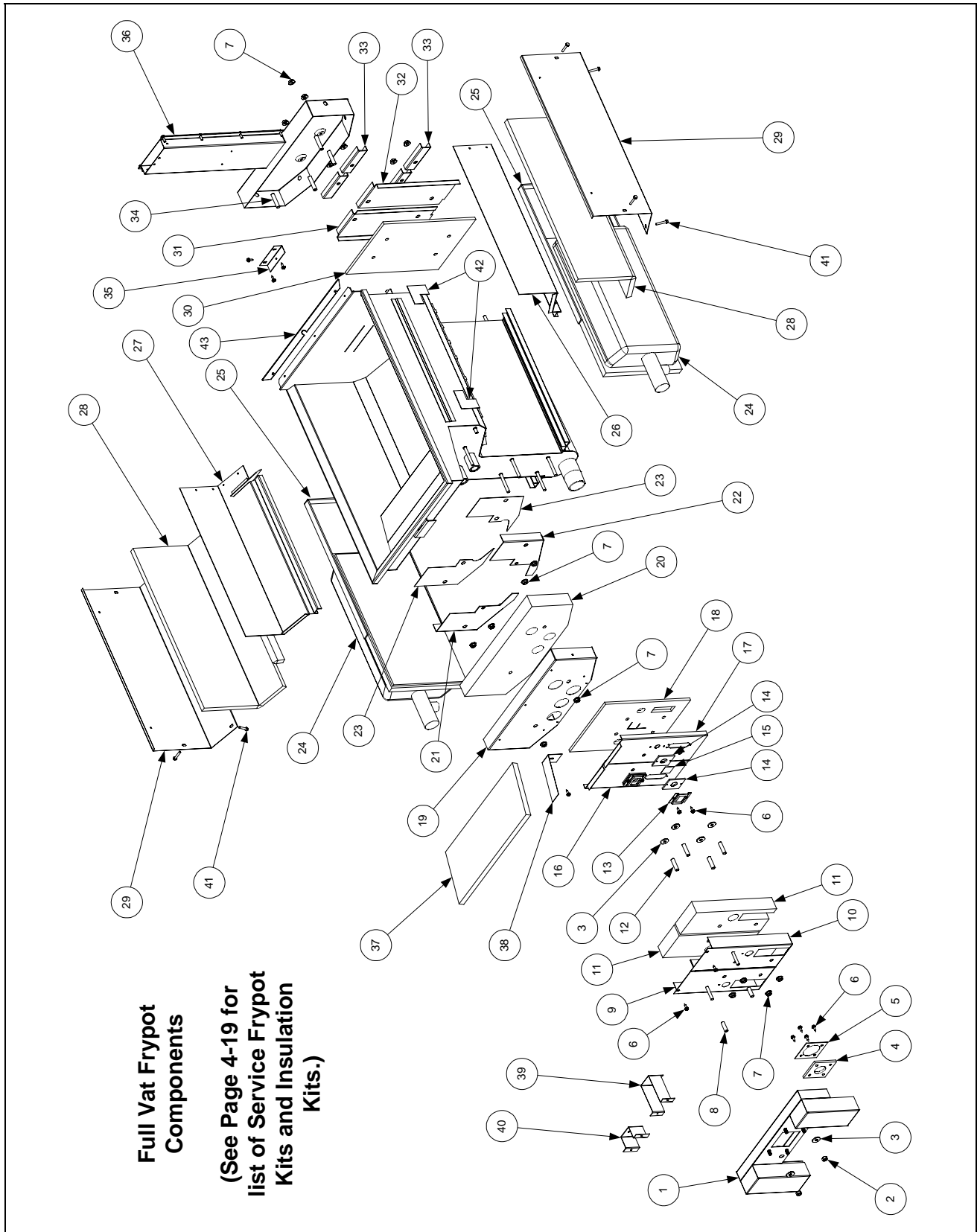

ITEM	PART #	COMPONENT
1	823-0969	Plenum (NOTE: use 823-1048 on units equipped with Air Switch)
2	826-1372	Nut, 1/4-20 Hex (Pkg of 10)
3	826-1383	Washer, 1/4-inch x 3/4-inch Flat (Pkg. of 5)
4	816-0057	Gasket, Plenum
5	900-1049	Retainer, Plenum Gasket
6	826-1371	Screw, #8 x 1/2-inch Hex Head (Pkg of 25)
7	826-1368	Nut, 1/4-20 Serrated Flange (Pkg. of 10)
8	810-0500	Spacer, 1/4-inch x 15/16-inch
9	823-11691SP	Retainer, Full Vat Left Outer Combustion Chamber Insulation
10	823-1169SP	Retainer, Full Vat Right Outer Combustion Chamber Insulation
11	816-0561	Insulation, Full Vat Combustion Chamber Outer
12	826-1340	Spacer, 1/4-inch x 1 3/16-inch (Pkg of 10)
13	900-1031	Retainer, Sight Glass
14	812-0356	Gasket, Sight Glass
15	814-0048SP	Sight Glass
16	200-0935	Retainer, Full Vat Left Inner Combustion Chamber Insulation
17	200-0934	Retainer, Full Vat Right Inner Combustion Chamber Insulation
18	812-0457	Insulation, Full Vat Inner Combustion Chamber
19	200-2227	Retainer, Full Vat Frypot Outer Front Insulation
20	816-0560	Insulation, Full Vat Frypot Outer Front
21	824-0863	Seal, Full Vat Frypot Left
22	824-0864	Seal, Full Vat Frypot Right
23	812-0404	Insulation, Frypot Seal
24		Kit, Burner Replacement (for use on either side; includes Item 25)
	826-1072	Natural and Propane Gas
	826-1073	Manufactured Gas
25	816-0577	Insulation, Burner
26	823-3142	Rail, Full Vat Right Burner
27	823-1777	Rail, Full Vat Left Burner
28	812-1029	Insulation, Frypot Side
29	900-4452	Retainer, Frypot Side Insulation
30	812-0355	Insulation, Full Vat Rear Combustion Chamber
31	200-0936	Back, Left Full Vat Combustion Chamber
32	200-0937	Back, Right Full Vat Combustion Chamber
33	900-1221	Retainer, Full Vat Combustion Chamber Back
34	810-0406	Spacer, 1/4-inch x 1 7/16-inch
35	930-0818	Bracket, Flue to Frypot Mounting
36	806-5859SP	Flue Assembly, Full Vat
37	812-0993	Insulation, Frypot Upper
38	900-1515	Retainer, Frypot Upper Insulation
39	900-0857	Bracket, BIH52 Frypot Mounting
40	900-1401	Bracket, MH52 Frypot Mounting
41	809-0362	Screw, #8 x 1-inch Hex Washer Head
42	812-0706	Insulation, Burner Rail
43	900-4253	Strip, Fluecap Retainer
*	910-2474	Pot-to-Pot Gap Clip
*	813-0156	Plug, 1/2-inch NPT (for blocking off unneeded ports in service frypot)
*	813-0336	Plug, 1/2-inch NPT SS (for blocking off unneeded ports in service frypot)

* Not illustrated.

4.3.3.2 Dual Vat

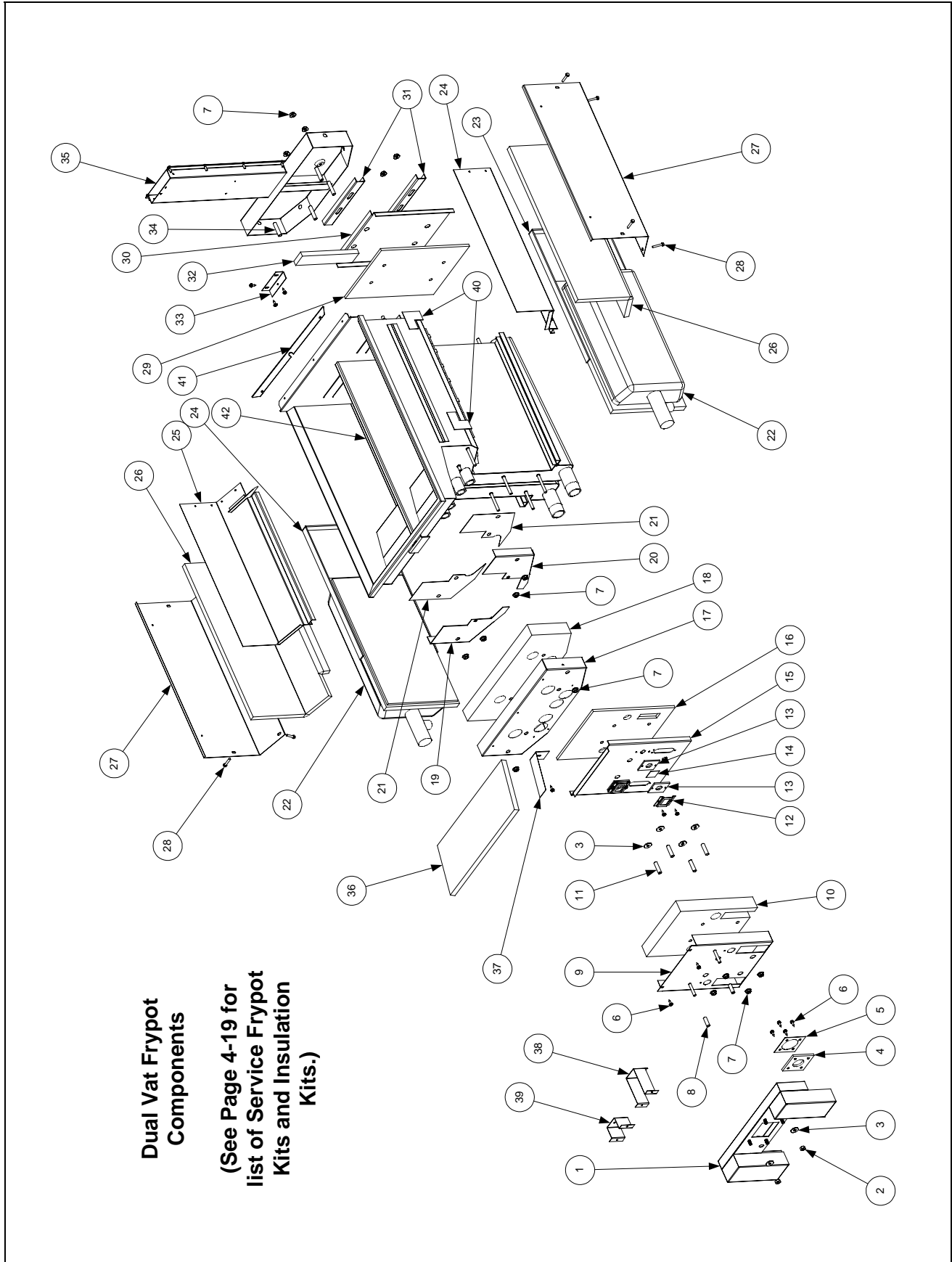

ITEM	PART #	COMPONENT
1		Plenum
	823-0970SP	Standard Dual Vat
	823-1049	For use on units with Air Switch. HE Dual Vat European
	823-2181	For use on JBIH152 models only.
2	826-1372	Nut, 1/4-20 Hex (Pkg of 10)
3	826-1383	Washer, 1/4-inch x 3/4-inch Flat (Pkg. of 5)
4	816-0057	Gasket, Plenum
5	900-1049	Retainer, Plenum Gasket
6	826-1371	Screw, #8 x 1/2-inch Hex Head (Pkg of 25)
7	826-1368	Nut, 1/4-20 Serrated Flange (Pkg. of 10)
8	810-0500	Spacer, 1/4-inch x 15/16-inch
9	823-0968SP	Retainer, Dual Vat Outer Combustion Chamber Insulation
10	816-0558	Insulation, Dual Vat Combustion Chamber Outer Lower
11	826-1340	Spacer, 1/4-inch x 1 3/16-inch (Pkg of 10)
12	900-1031	Retainer, Sight Glass
13	812-0356	Gasket, Sight Glass
14	814-0048SP	Sight Glass
15	823-0983SP	Retainer, Dual Vat Inner Combustion Chamber Insulation
16	812-0458	Insulation, Dual Vat Inner Combustion Chamber
17	930-3628	Retainer, Dual Vat Frypot Outer Front Insulation
18	816-0559	Insulation, Dual Vat Frypot Outer Front
19	824-0865	Seal, Dual Vat Frypot Left
20	824-0866	Seal, Dual Vat Frypot Right
21	812-0404	Insulation, Frypot Seal
22		Kit, Burner Replacement (for use on either side; includes Item 23)
	826-1072	Natural and Propane Gas
	826-1073	Manufactured Gas
23	816-0577	Insulation, Burner
24	823-2823	Rail, Dual Vat Right Burner Side W/A
25	823-2822	Rail, Dual Vat Left Burner Side W/A
26	812-1029	Insulation, Frypot Side
27	900-4452	Retainer, Frypot Side Insulation
28	809-0362	Screw, #8 x 1-inch Hex Washer Head
29	812-0354	Insulation, Dual Vat Rear Combustion Chamber
30	200-0941	Back, Dual Vat Combustion Chamber
31	900-0914	Retainer, Dual Vat Combustion Chamber Back
32	812-0688	Insulation, Dual Vat Gas Collector
33	930-0818	Bracket, Flue to Frypot Mounting
34	810-0406	Spacer, 1/4-inch x 1 7/16-inch
35	106-1018SP	Flue Assembly, Dual Vat
36	812-0993	Insulation, Frypot Upper
37	900-1515	Retainer, Frypot Upper Insulation
38	900-0857	Bracket, BIH52 Frypot Mounting
39	900-1401	Bracket, MH52 Frypot Mounting
40	812-0706	Insulation, Burner Rail
41	900-4253	Strip, Fluecap Retainer
42	824-0541	Riser, DV Pot Divider W/A
*	910-2474	Pot-to-Pot Gap Clip
*	813-0156	Plug, 1/2-inch NPT BM (for blocking off unneeded ports in service frypot)
*	813-0336	Plug, 1/2-inch NPT SS (for blocking off unneeded ports in service frypot)

* Not illustrated.

4.3.4 Service Frypot Kits, Insulation Kits, and Miscellaneous Service Parts

Service Frypot Kits

The fully assembled service frypot kits listed below contain all components illustrated on Pages 4-15 and 4-17 except the plenum, and the plenum gasket retainer. The kits also contain two Ignitor Gaskets (816-0059). These service frypot kits are ready for installation.

- 106-1043SP – Full Vat (Manufactured Gas)
- 106-1049SP – Full Vat (Natural Gas (G20/G25))
- 106-1050SP – Full Vat (Propane/Butane (G30/G31))
- 106-1066SP – Dual Vat (Manufactured Gas)
- 106-1079SP – Dual Vat (Natural Gas (G20/G25))
- 106-1080SP – Dual Vat (Propane/Butane Gas (G30/G31))

Insulation Kits, Complete

The insulation kits listed below contain all insulation illustrated on Pages 4-15 and 4-17, respectively. The kits also contain two Ignitor Gaskets (816-0059), two Sight Glasses (814-0048SP), two Plenum Gaskets (816-0057), one Upper Frypot Insulation Retainer (900-1515), and all spacers, screws, nuts, and washers required for installing the insulation.

- 826-0929 – Full Vat
- 826-0930 – Dual Vat

Insulation Kits, Burner

- 826-0931 – Full Vat
This kit includes the components listed. Item numbers refer to illustration on Page 4-15.
 - 816-0577 – Insulation, Burner (Item 25) (3 each)
 - 812-0457 – Insulation, Full Vat Inner Combustion Chamber (Item 18) (1)
 - 812-0355 – Insulation, Full Vat Rear Combustion Chamber (Item 30) (1)
 - 816-0057 – Gasket, Plenum (Item 4) (2 each)
- 826-0932 – Dual Vat
This kit includes the components listed. Item numbers refer to illustration on Page 4-17.
 - 816-0577 – Insulation, Burner (Item 23)
 - 812-0458 – Insulation, Dual Vat Inner Combustion Chamber (Item 17) (1)
 - 812-0354 – Insulation, Dual Vat Rear Combustion Chamber (Item 29) (1)
 - 816-0057 – Gasket, Plenum (Item 4)

Miscellaneous Frypot Service Parts

- 210-0681 – Probe Guard
- 806-6142SP – Riser Assembly, Flue (replaces upper section of Flue Assemblies 806-5859SP and 106-1018SP.)
- 900-2298 – Shutter, BIH152 Plenum

4.3.5 Gas Manifolds – Single BIH52/MH52 Units

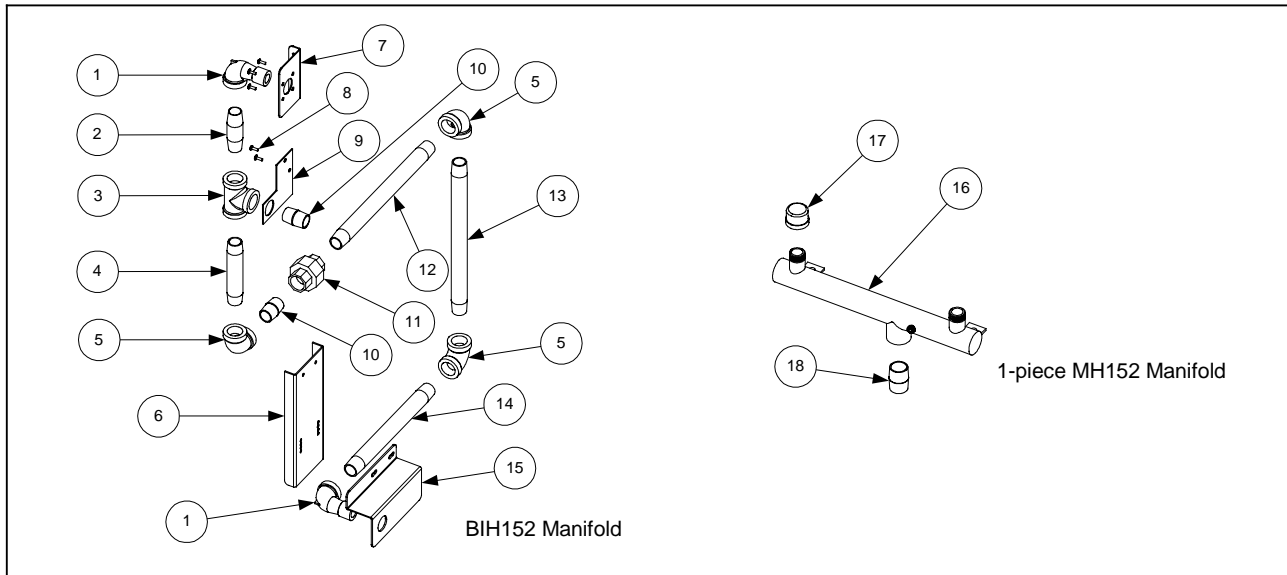

ITEM	PART #	COMPONENT
1	813-0165	Elbow, ½-inch NPT Street x 90°
2	813-0265	Nipple, ½-inch NPT x 2½-inch
3	813-0003	Tee, ½-inch NPT
4	813-0093	Nipple, ½-inch NPT x 4-inch
5	813-0062	Elbow, ½-inch NPT x 90°
6	900-5616	Mount, BIH152 Gas Line
7	900-5596	Mount, Valve Plate (used with Non-CE Gas Valves 810-0801/0802 only)
8	809-0107	Screw, 8-32 x ¾-inch Slotted Round Head
9	900-8740	Mount, Valve Plate (used with CE Gas Valve 810-1715 only)
10	813-0022	Nipple, ½-inch NPT Close
11	813-0173	Union, ½-inch NPT
12	813-0496	Nipple, ½-inch NPT x 9.5-inch
13	813-0253	Nipple, ½-inch NPT x 10-inch
14	813-0320	Nipple, ½-inch NPT x 8-inch
15	900-5615	Support, BIH152 Gas Line
16	810-0959	Manifold, MH152 1-piece Gas
17	813-0469	Cap, ½-inch NPT Pipe (closes off unused port in full vat configurations)
18	813-0109	Nipple, ¾-inch NPT Close
*	810-0478	Dormont Hose Assembly
*	810-1425	Fitting, ½-inch Quick Disconnect x ½-inch Female NPT

* Not illustrated.

4.3.6 Gas Manifolds – BIH52/MH52 Multi-Fryer Units

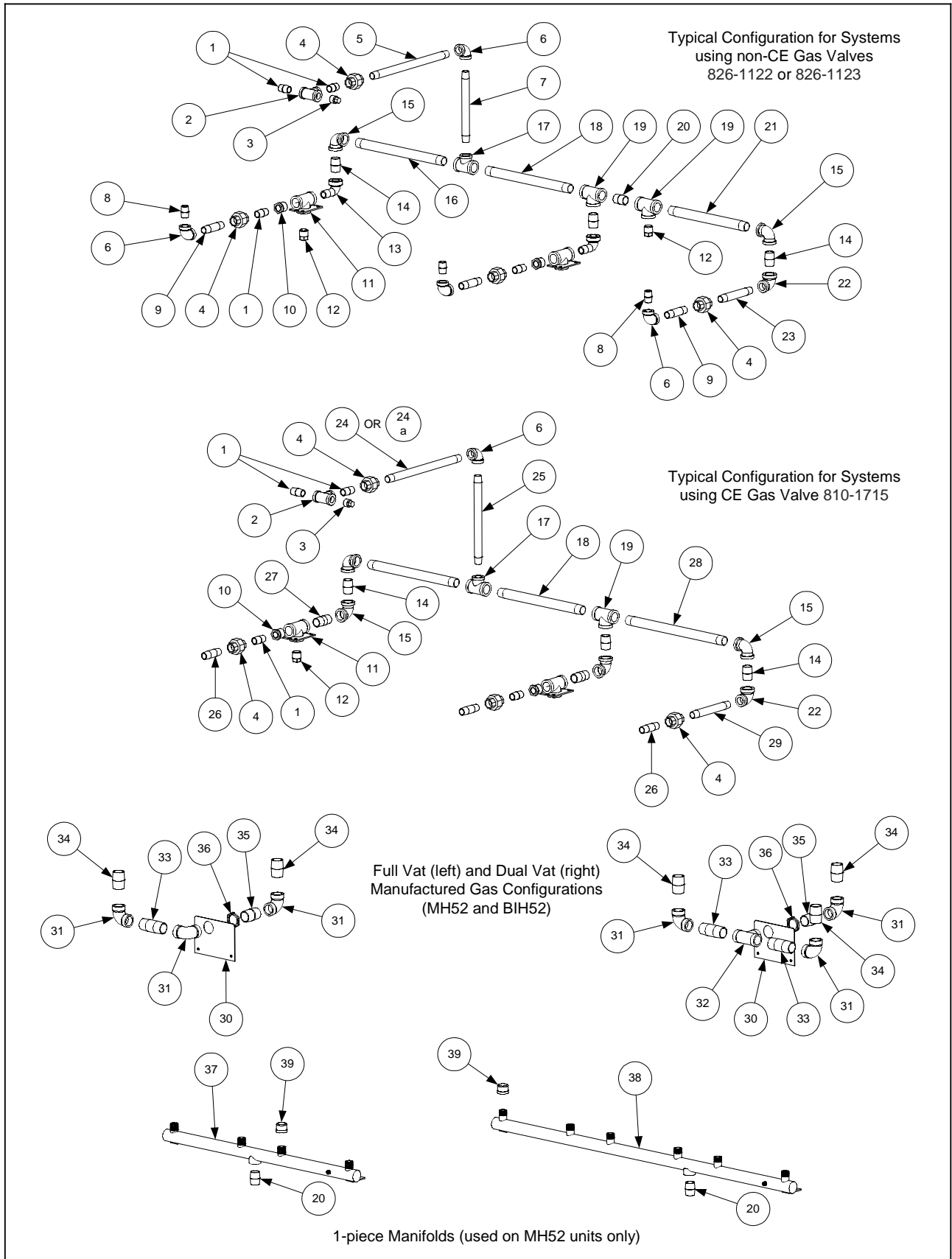

NOTE: The drawings on the preceding page illustrate typical gas manifold configurations. Specific configurations vary depending upon the number and types of fryers in a battery. The purpose of the drawings is to illustrate all individual components that may be found in any given configuration. Determination of which component to use in a particular application should be based upon careful inspection of the existing components, including taking measurements when appropriate.

ITEM	PART #	COMPONENT
1	813-0087	Nipple, ½-inch NPT x 1½-inch (3.8 cm)
2	813-0003	Tee, ½-inch NPT
3	813-0156	Plug, ½-inch NPT Pipe
4	813-0173	Union, ½-inch NPT
5	813-0497	Nipple, ½-inch NPT x 12½-inch (31.8 cm)
6	813-0062	Elbow, ½-inch NPT x 90°
7	813-0320	Nipple, ½-inch NPT x 8-inch (20.3 cm)
8	813-0022	Nipple, ½-inch NPT x Close
9	813-0460	Nipple, ½-inch NPT x 3-inch (7.6 cm)
10	813-0031	Bushing, ¾-inch NPT to ½-inch Reducer
11	823-2260	Bracket, ¾-inch NPT Gas Manifold Mounting
12	813-0157	Plug, ¾-inch NPT Pipe
13	813-0168	Elbow, ¾-inch NPT x 90° Street
14	813-0110	Nipple, ¾-inch NPT x 1½-inch (3.8 cm)
15	813-0066	Elbow, ¾-inch NPT x 90°
16	813-0478	Nipple, ¾-inch NPT x 12½-inch (31.8 cm)
17	813-0271	Tee, ¾-inch NPT x ½-inch Branch
18	813-0386	Nipple, ¾-inch NPT x 12-inch (30.5 cm)
19	813-0387	Tee, ¾-inch NPT
20	813-0109	Nipple, ¾-inch NPT x Close
21	813-0479	Nipple, ¾-inch NPT x 11-inch (27.9 cm)
22	813-0068	Elbow, ¾-inch NPT x ½-inch NPT x 90°
23	813-0281	Nipple, ½-inch NPT x 5-inch (12.7 cm)
24	813-0515	Nipple, ½-inch NPT x 12-inch (30.5 cm)
24a	813-0360	Nipple, ½-inch x 14-inch (in CE BIH352-6 Natural Gas (G20/G25) units only)
25	813-0253	Nipple, ½-inch NPT x 10-inch (25.4 cm)
26	813-0265	Nipple, ½-inch NPT x 2½-inch (6.4 cm)
27	813-0112	Nipple, ¾-inch NPT x 2-inch (5.1 cm)
28	813-0476	Nipple, ¾-inch NPT x 14-inch (35.6 cm)
29	813-0096	Nipple, ½-inch NPT x 6-inch (15.2 cm)
30	900-0944	Plate, 1-inch NPT Gas Manifold Mounting
31	813-0202	Elbow, 1-inch NPT x 90°
32	813-0314	Tee, 1-inch NPT
33	813-0318	Nipple, 1-inch NPT x 3-inch (7.6 cm)
34	813-0138	Nipple, 1-inch NPT x Close
35	813-0371	Nipple, 1-inch NPT x 2-inch (5.1 cm)
36	809-0347	Nut, 1-inch NPT Retainer
37	810-0661	Manifold, 1-piece H252 Gas
38	810-0660	Manifold, 1-piece H352 Gas
39	813-0469	Cap, ½-inch NPT Pipe (closes off unused port in full vat configurations)

4.3.7 Gas Valves, Gas Lines and Fittings

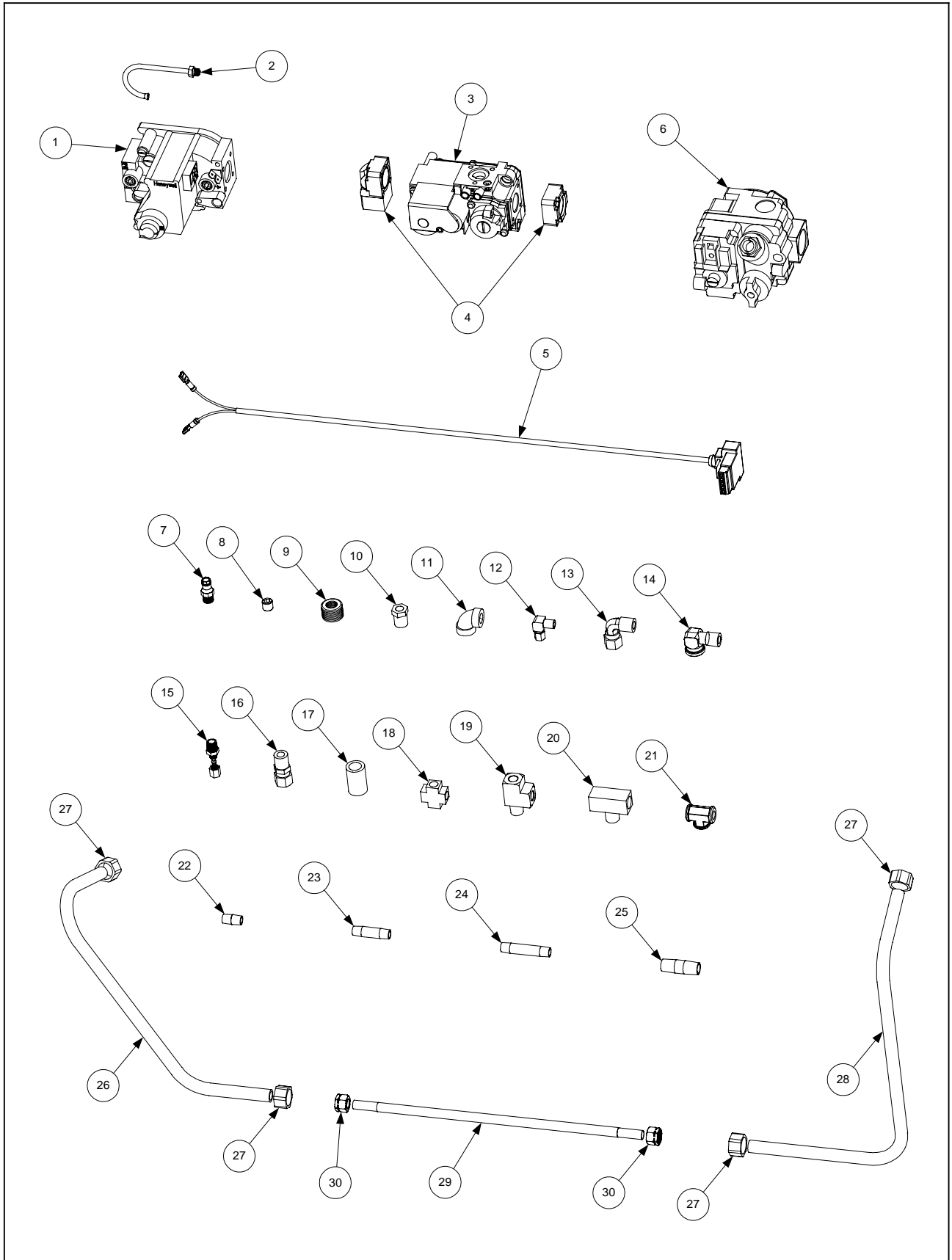

ITEM	PART #	COMPONENT
1		Gas Valve, Non-CE Kit
	826-1122	Natural Gas (G20/G25)
	826-1123	Propane (LP) Gas (G30/G31)
2	810-0691	Vent Tube (used with Item 1)
	826-1576	CE Gas Valve Kit (includes items 3 and 4)
3	810-1715	Gas Valve, Universal CE (G20/G25/G30/G31)
4	810-1041	Accessory Kit (2 straight and 2 elbow flanges, screws, O-rings, LP gas spring)
5	806-9678	Plug Assembly, CE Gas Valve (used with Item 3)
6	807-1229	Gas Valve, Manufactured Gas
7	810-1176	Tap, 1/8-inch NPT Pressure
8	813-0411	Plug, 1/8-inch NPT Allen-head Pipe
9	813-0304	Bushing, 1/2-inch to 1/4-inch NPT Reducer
10	810-1006	Bushing, 1/4-inch to 1/8-inch NPT Reducer
11	813-0004	Elbow, 90° x 1/8-inch NPT
12	813-0354	Elbow, 90° x 1/8-inch NPT x 1/8-inch Tube (Brass)
13	813-0302	Elbow, 90° x 3/8-inch Tube x 1/4-inch Male NPT (Brass)
14	813-0502	Elbow, 90° Street x 1/4-inch (Brass)
15	813-0340	Connector, 1/8-inch Tube to 1/8-inch Male NPT (Brass)
*	810-0502	Connector, 1/8-inch Tube to 1/8-inch Male NPT (Brass) (with Item 6 only)
16	810-1025	Connector, 3/8-inch Tube to 1/4-inch Male NPT (Brass)
17	813-0507	Coupling, 1/4-inch NPT (Brass)
18	813-0378	Cross Fitting, 1/2-inch Female NPT (Brass)
19	810-1026	Tee, 1/4-inch NPT Street (Brass)
20	813-0495	Tee, 1/4-inch Male NPT Branch (Brass)
21	813-0377	Tee, 1/8-inch Female NPT (Brass)
22	813-0016	Nipple, 1/8-inch NPT Close
23	813-0315	Nipple, 1/8-inch NPT x 1 1/2-inch (4.8 cm)
24	813-0405	Nipple, 1/8-inch NPT x 2-inch (5.1 cm)
25	813-0471	Nipple, 1/4-inch NPT x 1 1/2-inch (4.8 cm)
26	900-3739	Gas Tube (Left), H52 FV Manufactured Gas (pre-formed)
27	810-0503	Compression Nut (Ferrule), 1/2-inch Manufactured Gas Tube
28	900-3737	Gas Tube (Right), H52 FV Manufactured Gas (pre-formed)
*	900-3735	Gas Tube (Left and Right), H52 DV Manufactured Gas (pre-formed)
29		Flexible Stainless Steel Gasline (Flexline), 3/8-inch OD
	810-1353	9-inch (22.9 cm) Kit 826-1530 includes 2 of #30
	810-1354	12-inch (30.5 cm) Kit 826-1531 includes 2 of #30
	810-1355	15-inch (38.1 cm) Kit 826-1532 includes 2 of #30
30	810-0494	Compression Nut (Ferrule), 3/8-inch Flexible Gas Line
*		Enrichment Tube
	811-0752	5 1/2-inch (14 cm)
	811-0756	8 1/2-inch (21.6 cm)
	811-0800	12 1/2-inch (31.8 cm)
	812-0742	18-inch (45.7 cm)

— Brass Comp. Fitting 810-0502 for ignitor end
— Brass Comp. Fitting 810-0340 for gas valve end

* Not illustrated.

4.4 Electronics

4.4.1 Computers, Controllers and Associated Components

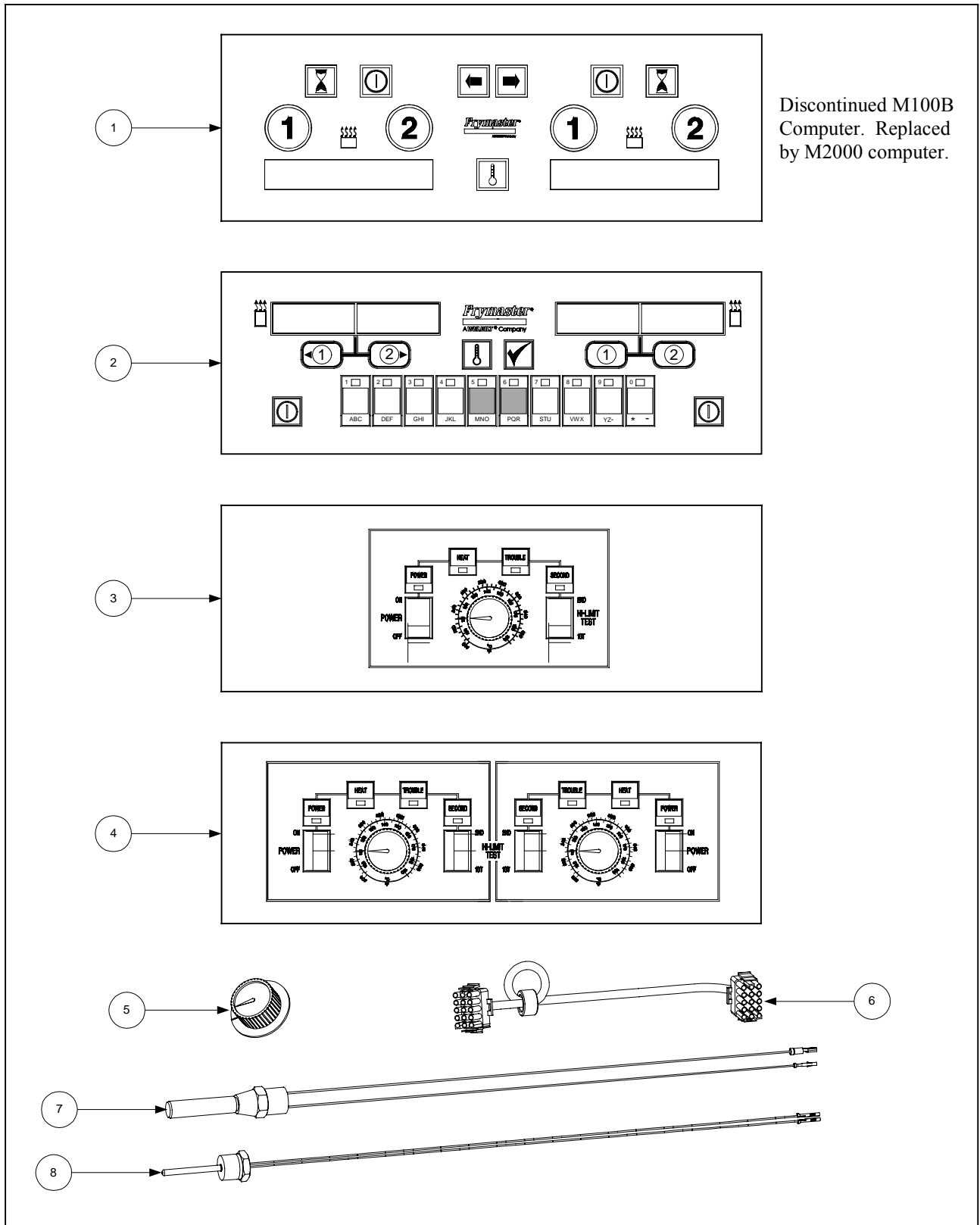

ITEM	PART #	COMPONENT
1		Computer, McDonald's M100B has been replaced by M2000
	826-1739	U.S.,Canada and Non-CE Export with 6-second Melt Cycle - <i>Replacement Upgrade Kit</i>
	806-8041E	Non-CE Export with 8-second Melt Cycle (M100B Obsolete)
	806-8040	Factory-programmed in French (M100B Obsolete)
	826-1810	CE Export - <i>Replacement Upgrade Kit</i>
2		Computer, McDonald's M2000 Gas Fryer
	106-0529B	U.S. and Canada FV / Non-CE Export
	106-2436B	CE Export FV
3		Controller, McDonald's Full Vat Gas Fryer Solid-State
	806-3007	With 6-second Melt Cycle
	806-3571	With 8-second Melt Cycle
4		Controller, McDonald's Dual Vat Gas Fryer Solid-State
	806-3009	With 6-second Melt Cycle
	806-3572	With 8-second Melt Cycle
5	810-0387	Knob, Replacement Control (for use on Solid-State Controllers)
6	806-2071	Cable, Computer/Controller to Interface Board
7	826-1177	Thermostat, High-Limit Kit
8	806-4206	Probe Assembly, Temperature
*	826-1739	Retrofit Kit, Solid-State Controller to M100B Computer
*	826-1675	M100B to M2000 Speaker and Mount Retrofit Kit
*	806-3660	Sound Device, High Output for M100B
*	807-1617	M2000 Speaker
*	826-1032SP	Screw and Retainer Kit for computer

* Not illustrated.

4.4.2 Component Boxes

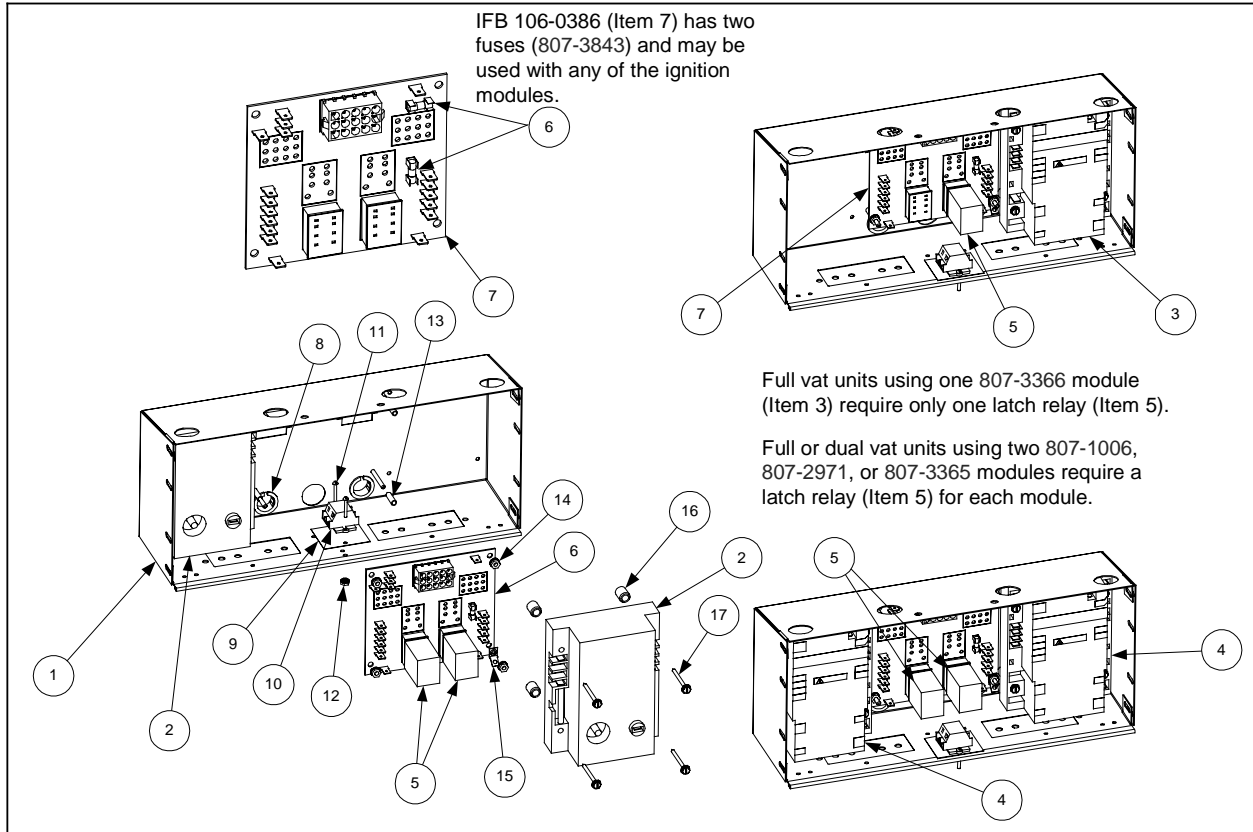

ITEM	PART #	COMPONENT
1	200-5996	Box Assembly, One-Piece Component
2	807-1006	Ignition Module, Full or Dual Vat (fuse-protected)
*	807-2971	Ignition Module, Full or Dual Vat (fuse-protected) (Australian units only)
3	807-3366	Ignition Module, Full Vat (unfused – <i>use inline fuse 106-0531SP</i>)
4	807-3365	Ignition Module, Dual Vat (unfused – <i>use inline fuse 106-0531SP</i>)
5	807-0833	Relay, 12V 5Amp Latch
6	807-3843	Fuse, 3A 250V Subminiature
7	106-0386	Interface Board (double fuse-protected) (use with 807-3365, 807-1006 or 807-3366)
*	806-4973	Interface Board (used with 240V manufactured gas units only)
8	807-1926	Bushing, .875 Diameter Split
9	816-0217	Paper, Insulating (Items 9, 10, 11, 12 not used on BIH152 or Hong Kong units)
10	810-1164	Block, Terminal (See Item 9)
11	826-1359	Screw, 4-40 x 3/4-inch Slotted Round Head (See Item 9) (Pkg. of 25)
12	826-1366	Nut, 4-40 Keps Hex (See Item 9) (Pkg. of 25)
13	807-1241	Spacer, Interface Board (.151-inch ID x 5/8-inch)
14	809-0250	Nut, 6-32 Keps Hex
15	826-1337	Tab, Push-On Terminal (Pkg. of 5)
16	826-1346	Spacer, Ignition Module (.260-inch ID x 1/2-inch) (Pkg. of 10)
17	809-0441	Screw, #7 x 1 1/2-inch Slotted Washer Hex Head
*	810-2243	Spring, Relay Clip Hold Down
*	806-3660	Sound Device, High Output (<i>Use 807-3520 with M2000 Computers</i>)
*	807-1359	Mount, Tie-Wrap (used on CE units only)

* Not illustrated.

4.4.3 Filter Box Components

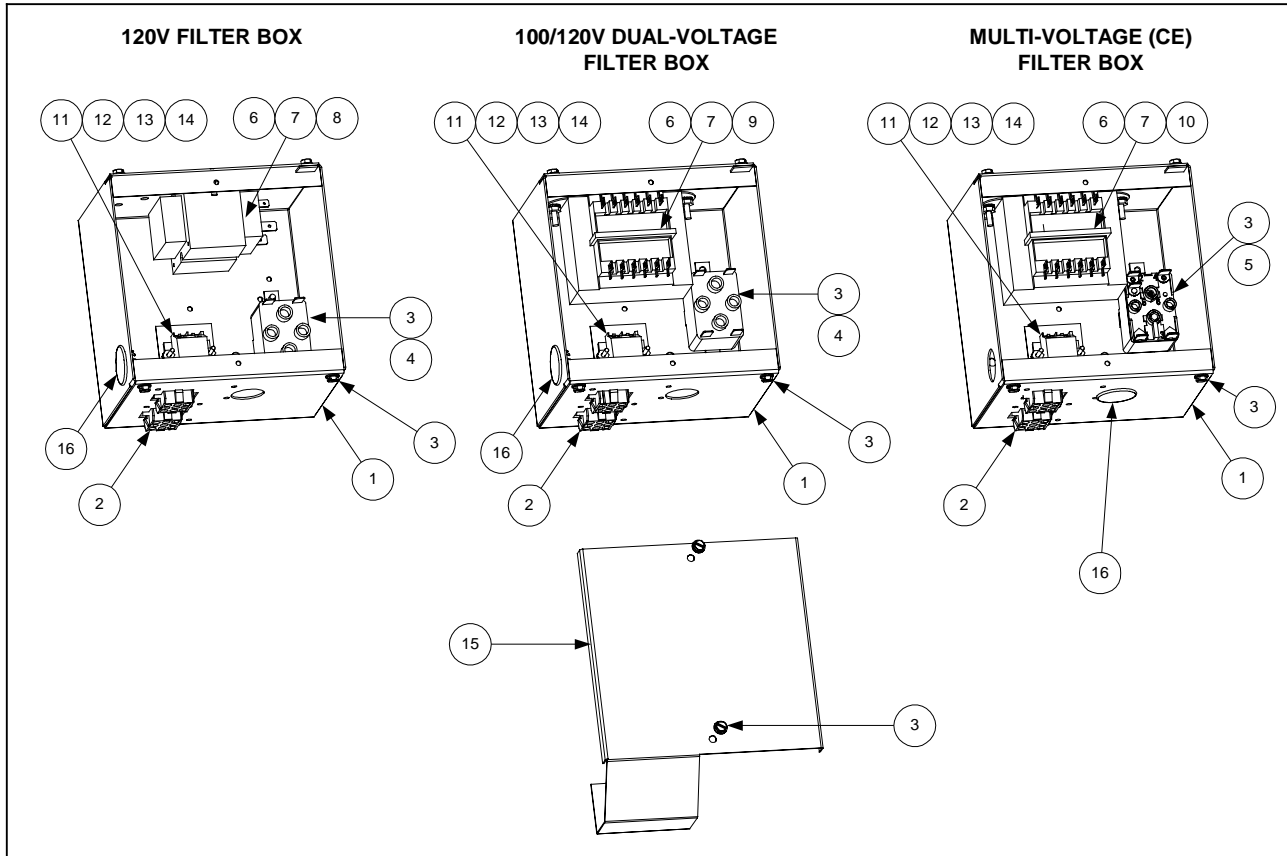

ITEM	PART #	COMPONENT
1	900-5250	Box, Filter
2	807-0156	Connector, 9-Pin Female
*	807-2518	Plug, Mate-N-Lock Keying (used w/Item 2)
3	809-0360	Screw, #8 x 3/8-inch Hex Washer Slot Head
4	807-0012	Relay, Non-CE 18 Amp 1/3-HP 24V Coil 4 Pole
5	807-2434	Relay, CE 18 Amp 1/3-HP 24V Coil 5 Pole
6	809-0096	Screw, 6-32 x 5/8-inch Slot Head
7	809-0250	Nut, 6-32 Keps Hex
8	807-0800	Transformer, 120/24VAC 50/60Hz 50VA
9	807-2176	Transformer, Dual Voltage (100 or 120/24/12VAC) 50/60Hz 50VA
10	807-1999	Transformer, Multi-Voltage (208, 220, 230, 240/24VAC) 50/60Hz 50VA
11	816-0217	Paper, Insulating
12	810-1164	Block, Terminal
13	826-1359	Screw, 4-40 x 3/4-inch Round Slot Head (Pkg. of 25)
14	826-1366	Nut, 4-40 Keps Hex (Pkg. of 25)
15	900-5530	Cover, Filter Box
16	810-0044	Plug, .875 Button
*	806-8021SP	Upper Plug Heater Plug
*	806-7494SP	Lower Plug Heater Plug

* Not illustrated.

NOTE: See Page 4-31 for associated wiring assemblies.

4.4.4 Transformer Box Components

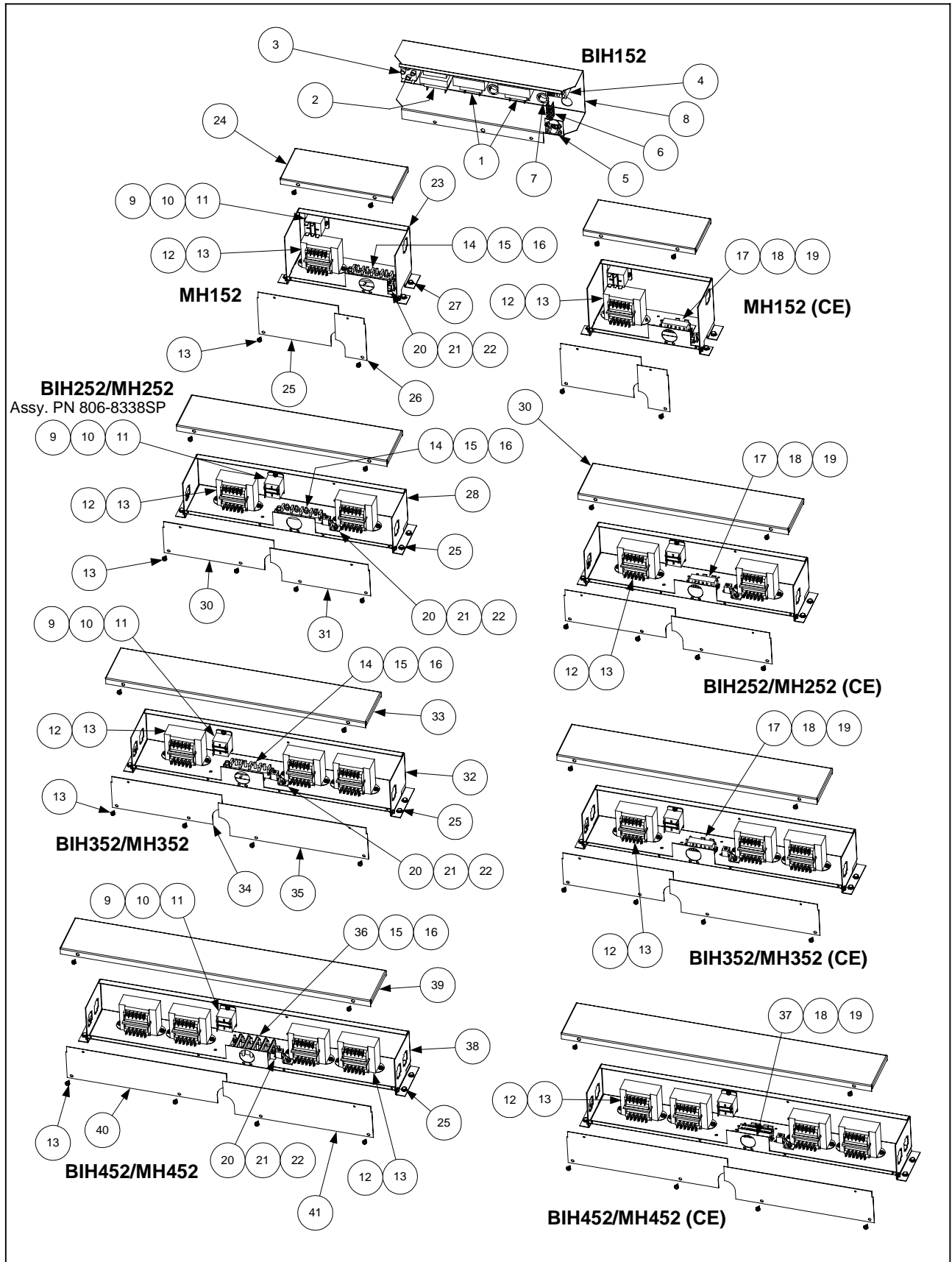

ITEM	PART #	COMPONENT
1		Transformer (for use in BIH152 units)
	807-1238	100/24VAC 50 Hz
	807-0800	120/24VAC 50/60 Hz
2	807-0855	Transformer, 120/12VAC 50/60 Hz (for use in BIH152 units)
3	807-0012	Relay, 18 Amp 24VDC Coil
4	807-0273	Block, 16-Pin Terminal
5	807-1612	Clamp, 3/8-inch Strain Relief
6	807-0255	Jumper, Double
7	810-0045	Bushing, .875-inch Diameter
*	809-0362	Screw, 8-32 x 1-inch Hex Slotted Washer Head (for mounting Items 1-4)
8	900-5560	Shield, BIH152 Transformer
9	807-1683	Relay, 15 AMP 12VDC Coil
10	826-1363	Screw, 8-32 x 1/2-inch Slotted Truss Head (Pkg. of 25)
11	809-0050	Nut, 8-32 Hex
12		Transformer (for use in MH152 and BIH252/352/452/552 units)
	807-2176	100-120/24/12VAC (used in U.S., Japanese, and Korean units) Dual Voltage
	807-1999	208-240/24/12VAC (used in CE and most export units) Dual Voltage
13	809-0360	Screw, 8-32 x 3/8-inch Slotted Hex Washer Head
14	807-1973	Block, 4-Post Threaded Terminal (used in Non-CE units)
15	826-1389	Screw, 1/4-20 x 3/4-inch Hex Head (Pkg. of 10)
16	826-1362	Nut, 1/4-20 Hex (Pkg. of 10)
*	809-0052	Nut, 10-24 Hex (for use on Item 14 and Item 36 terminal posts)
17	810-1163	Block, 3-Position Push-In Terminal (used in CE units)
18	826-1359	Screw, 4-40 x 3/4-inch Slotted Round Head (Pkg. of 25)
19	826-1366	Nut, 4-40 Keps Hex (Pkg. of 10)
20	807-0070	Terminal, Lug
21	826-1363	Screw, 8-32 x 1/2-inch Slotted Truss Head (Pkg. of 25)
22	809-0247	Nut, 8-32 Keps Hex
23	900-2697	Box, MH152 Transformer
24	900-2708	Cover, MH152 Transformer Box Top
25	900-2703	Cover, MH152 Transformer Box Left
26	900-2709	Cover, MH152 Transformer Box Right
27	826-1374	Screw, #10 x 1/2-inch Self-Tapping Slotted Hex Washer Head (Pkg of 25)
28	900-5924	Box, BIH252/MH252 Transformer
29	900-5927	Cover, BIH252/MH252 Transformer Box Top
30	900-5928	Cover, BIH252/MH252 Transformer Box Left
31	900-5923	Cover, BIH252/MH252 Transformer Box Right
32	900-5925	Box, BIH352/MH352 Transformer Box
33	900-5929	Cover, BIH352/MH352 Transformer Box Top
34	900-5928	Cover, BIH352/MH352 Transformer Box Left
35	900-5930	Cover, BIH352/MH352 Transformer Box Right
36	807-2608	Block, 8-Post Threaded Terminal (used in Non-CE units)
37	810-1162	Block, 4-Position Push-In Terminal (used in CE units)
38	900-5926	Box, BIH452/MH452 Transformer
39	900-5931	Cover, BIH452/MH452 Transformer Box Top
40	900-5932	Cover, BIH452/MH452 Transformer Box Left
41	900-5930	Cover, BIH452/MH452 Transformer Box Right
*	807-0156	Connector, 9-Pin Plug

* Not illustrated.

4.4.5 Wiring

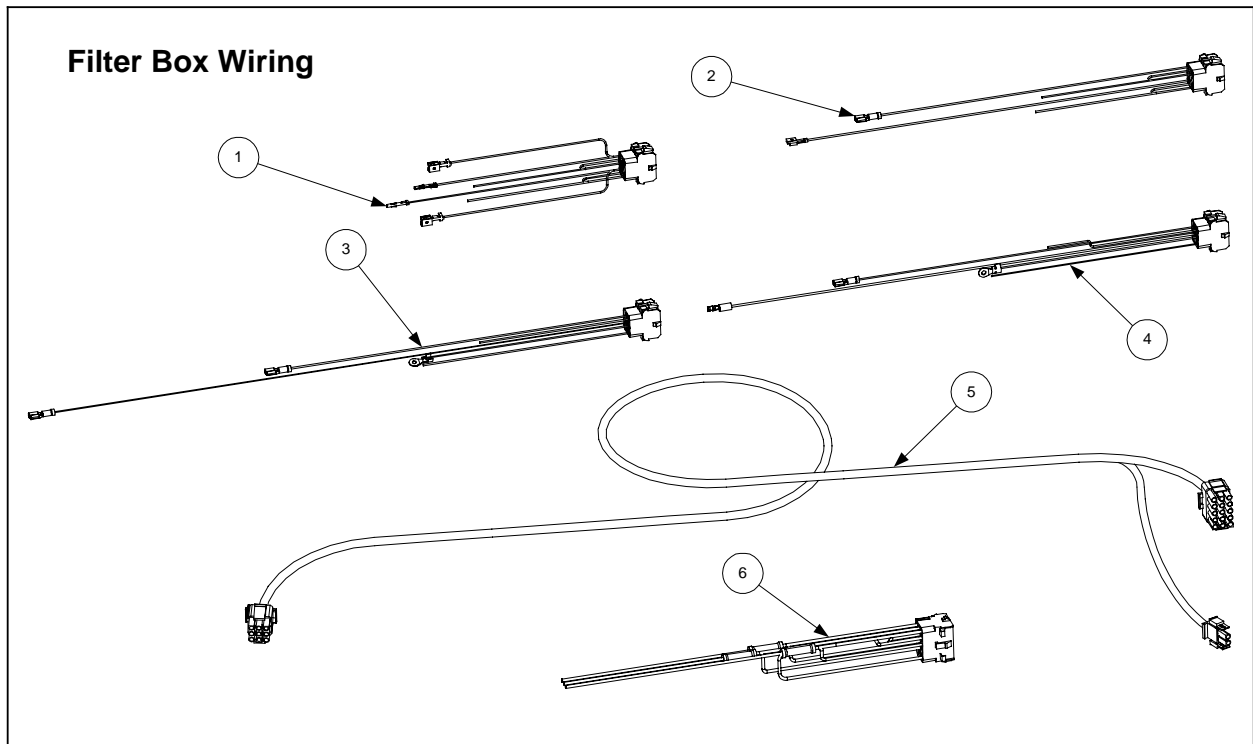

ITEM	PART #	COMPONENT
1	806-8021SP	120V U.S. and 100/120V Non-CE Export Upper 9-Pin Plug Assembly
2	806-7494SP	120V U.S. Lower 9-Pin Plug Assembly
3	806-6725SP	230V CE Upper 9-Pin Plug Assembly
4	806-6719SP	100/120V Non-CE Export and 230V CE Lower 9-Pin Plug Assembly
5	810-1062	Cable, Filter Box Lower 9-Pin Plug to 807-2001 15-Pin (C2) Connector
6	807-2001	Cable, 810-1062 C2 Connector to Filter Terminal Block
*	806-6728SP	Pump Motor to Filter Box Wiring Assembly
*	810-0366	Strain Relief 9-pin
*	WIR0287SP	120V U.S. Filter Box Internal Wiring
*	WIR0233SP	100-250V CE and Non-CE Export Filter Box Internal Wiring

* Not illustrated.

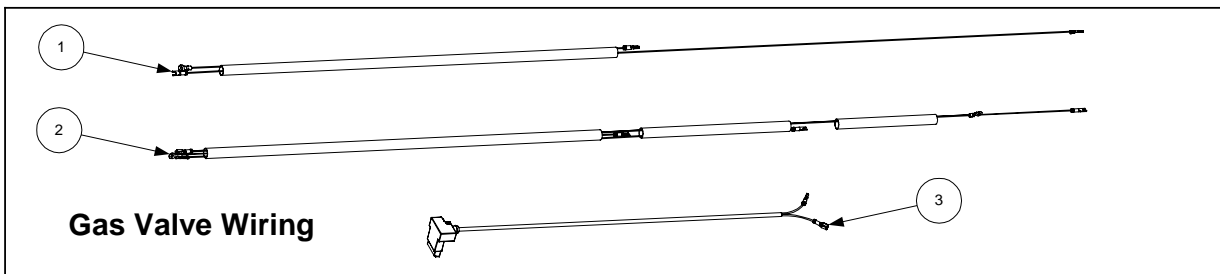

ITEM	PART #	COMPONENT
1	806-3941SP	Harness, Full Vat Gas Valve
2	806-3940SP	Harness, Dual Vat Gas Valve
3	806-9678SP	Plug Assembly, CE Gas Valve

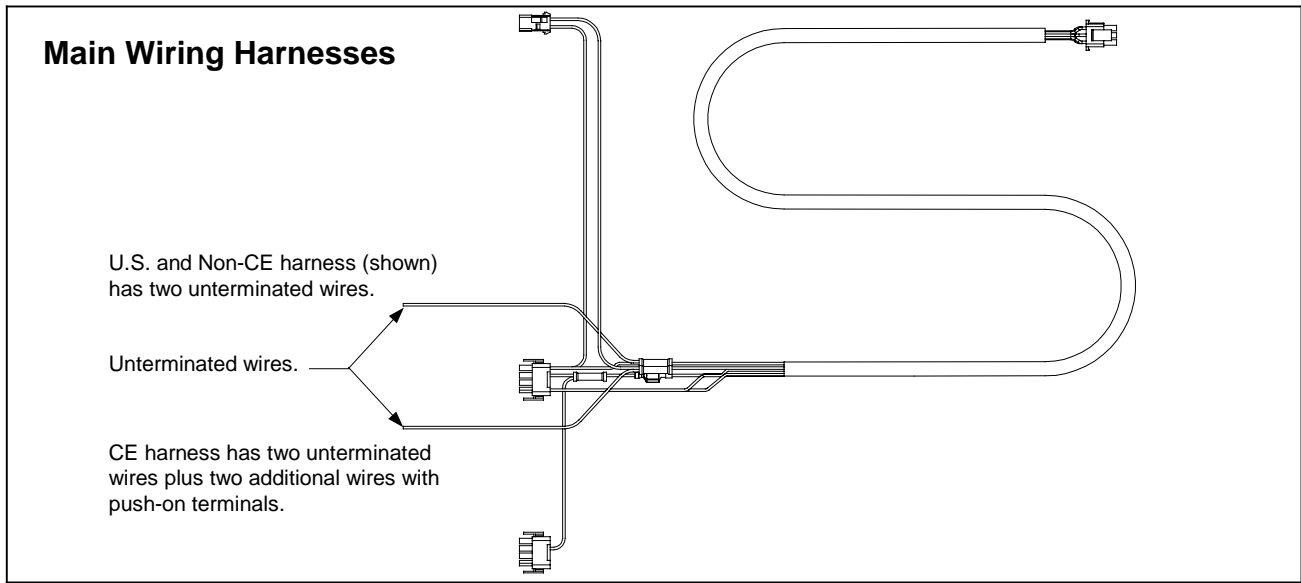

ITEM	PART #	COMPONENT
	807-1978	U.S. and Non-CE Export MH/BIH52 Main Wiring Harness
	807-2168	CE MH/BIH52 Main Wiring Harness

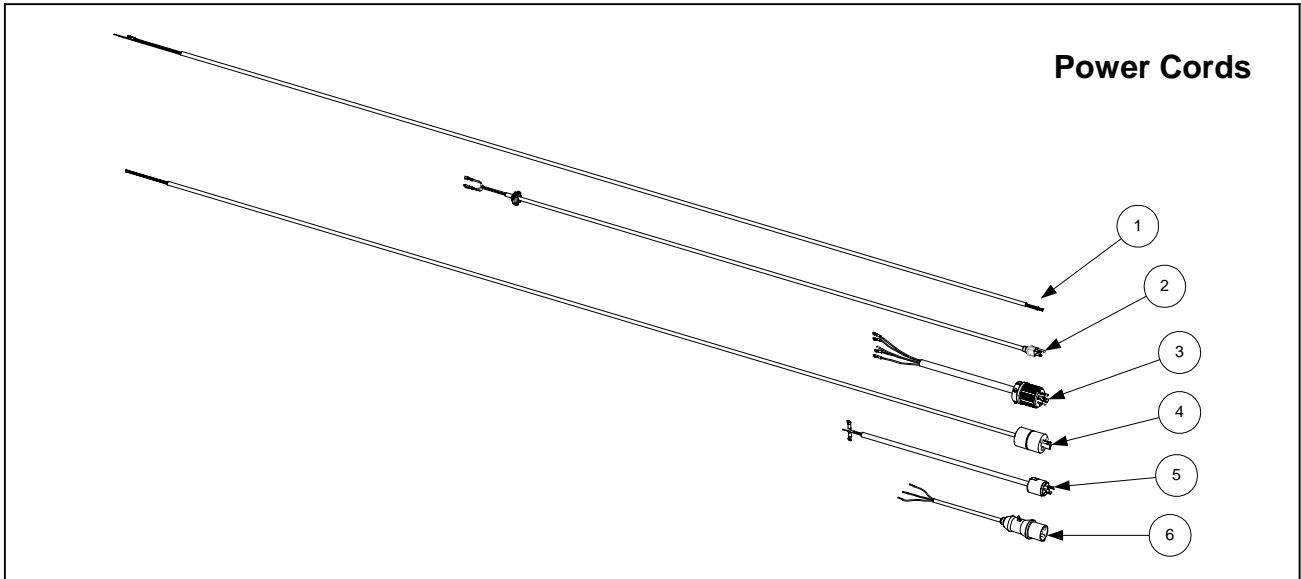

ITEM	PART #	COMPONENT
1	806-9786	3-Wire without Plug, 450V (Non-CE Export)
2	806-5332SP	3-Wire with 3-Prong Molded Plug, (U.S., CE, and Non-CE Export)
3	806-6083	5-Wire with 4-Prong Twist-Lock Plug, 120V (U.S. and Non-CE Export)
	807-1558	5-Wire, 4 pole plug 20A only
4	807-1871	3-Wire with 3-Prong Twist-Lock Plug, 125V (Mexico and South America)
5	806-9285	3-Wire with 3-Prong Twist-Lock Plug, 250V (Far East and Pacific Rim)
6	807-1696	3-Wire with 3-Pin Sleeved Plug, 230V (CE)
*	807-1560	Strain Relief

* Not illustrated.

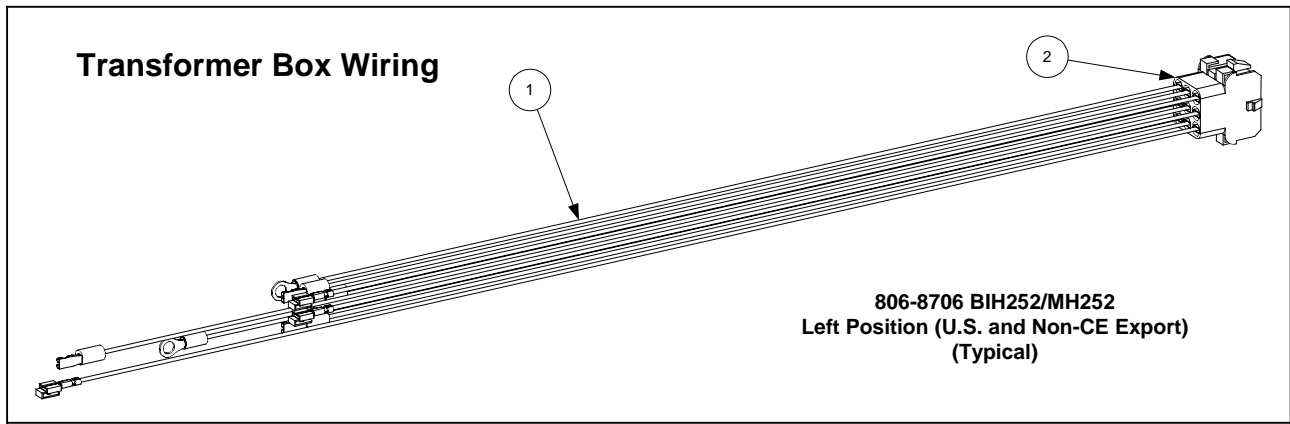

ITEM	PART #	COMPONENT
1		Plug and Wire Assembly, Transformer Box 9-Pin Female
	806-6077	MH152 (U.S. and Non-CE Export)
	806-6597	MH152 (CE)
	806-8706SP	BIH252/MH252, Left Position (U.S. and Non-CE Export)
	806-8707SP	BIH252/MH252, Right Position (U.S. and Non-CE Export)
	806-8719	BIH252/MH252, Right Position (CE)
	806-8720	BIH252/MH252, Left Position (CE)
	806-8708SP ¹	BIH352/MH352, Left Front Position (U.S. and Non-CE Export)
	806-8709SP ²	BIH352/MH352, Left Rear Position (U.S. and Non-CE Export)
	806-8710SP ³	BIH352/MH352, Right Position (U.S. and Non-CE Export)
	806-8718 ⁴	BIH352/MH352, Right Position (CE)
	806-8721 ⁵	BIH352/MH352, Left Front Position (CE)
	806-8722 ⁶	BIH352/MH352, Left Rear Position (CE)
	806-8723SP	BIH452/MH452, Right Front Position (CE)
		Internal Wiring Bundles
2	807-0156	9-pin connector
*	WIR0288	100-240V BIH152 (U.S., CE, and Non-CE Export)
*	WIR0109	100-240V MH152 (U.S. and Non-CE Export)
*	WIR0100SP ⁷	100-240V BIH252/MH252 (U.S. and Non-CE Export)
*	WIR0101SP ⁸	100-240V BIH352/MH352 (U.S. and Non-CE Export)
*	WIR0102SP	100-240V BIH452/MH452 (U.S. and Non-CE Export)
*	WIR0144	230V MH152 (CE)
*	WIR0141 ⁹	230V BIH252/MH252 (CE)
*	WIR0142 ¹⁰	230V BIH352/MH352 (CE)
*	WIR0143	230V BIH452/MH452 (CE)

* Not illustrated.

NOTES:

1. Also used in Left Front Position of BIH452/MH452 (U.S. and Non-CE Export)
2. Also used in Left Rear Position of BIH452/MH452 (U.S. and Non-CE Export)
3. Also used in Right Rear Position of BIH452/MH452 (U.S. and Non-CE Export)
4. Also used in Right Rear Position of BIH452/MH452 (CE)
5. Also used in Left Front Position of BIH452/MH452 (CE)
6. Also used in Left Rear Position of BIH452/MH452 (CE)
7. Also used in BIH552 (U.S. and Non-CE Export)
8. Also used in BIH552 (U.S. and Non-CE Export)
9. Also used in BIH552 (CE)
10. Also used in BIH552 (CE)

4.5 Oil Handling System Components

4.5.1 Drain System Components

4.5.1.1 Square Drain Sections and Seal Components

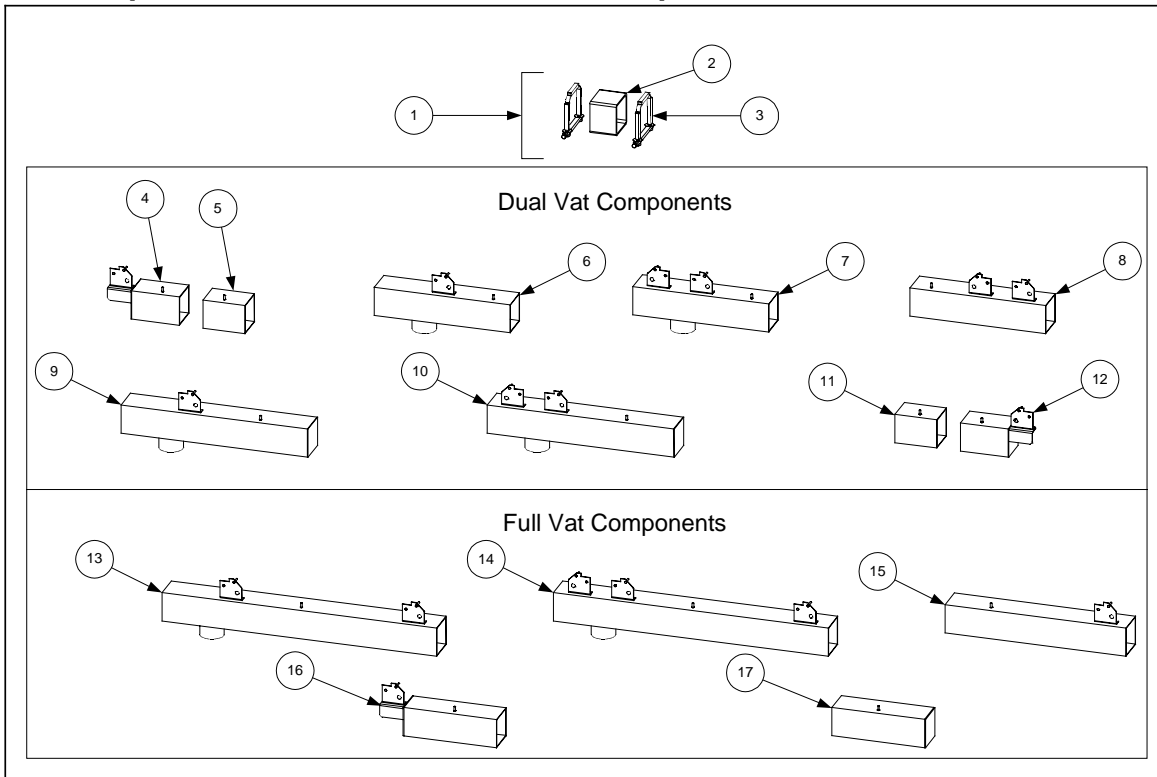

ITEM	PART #	COMPONENT
1	KIT-0257SP	Clamp Assembly and Seal Kit
2	816-0420	Seal (Rubber Boot)
3	806-6374SP	Clamp Assembly
4	823-2199	Dual Vat Left End Outer Section (4.12-inches/10.5 cm)
5	823-2212	Dual Vat Left End Inner Section (3.57-inches/9.1 cm)
6	823-2204	Dual Vat Outlet Section with 1 Bracket (11.55-inches/29.3 cm)
7	823-2192	Dual Vat Outlet Section with 2 Brackets (11.55-inches/29.3 cm)
8	823-2202	Dual Vat Drain Section with 2 Brackets (11.55-inches/29.3 cm)
9	823-2211	Dual Vat Closed Outlet Section with 1 Bracket (15.86-inches/40.3 cm)
10	823-2210	Dual Vat Closed Outlet Section with 2 Brackets (15.86-inches/40.3 cm)
11	823-2212	Dual Vat Right End Inner Section (3.57-inches/9.1 cm)
12	823-2194	Dual Vat Right End Outer Section (4.12-inches/10.5 cm)
13	823-2200	Full Vat Outlet Section with 2 Brackets (23.38-inches/59.4 cm)
14	823-2207	Full Vat Outlet Section with 3 Brackets (23.38-inches/59.4 cm)
15	823-2233	Full Vat Drain Section with 1 Bracket (15.39-inches/39.1 cm)
16	823-2197	Full Vat Left End Section (7.95-inches/20.2 cm)
17	823-2198	Full Vat Right End Section (7.95-inches/20.2 cm)
*	811-0932	Vent Tube, Teflon 3/8" OD Bulk
*	813-0408	¼ Pipe Plug, Used when vent tube is not used.
*	816-0123	Cap-Square Drain (KIT0256 End Cap Kit)
*	810-1372	Elbow, 90° Vent Tube (used with Items 4 and 16)

* Not illustrated.

NOTE: Item 5 is always used left of outlet section; Item 11 is always used right of outlet section.

4.5.1.2 Drain Valve Assemblies and Associated Components

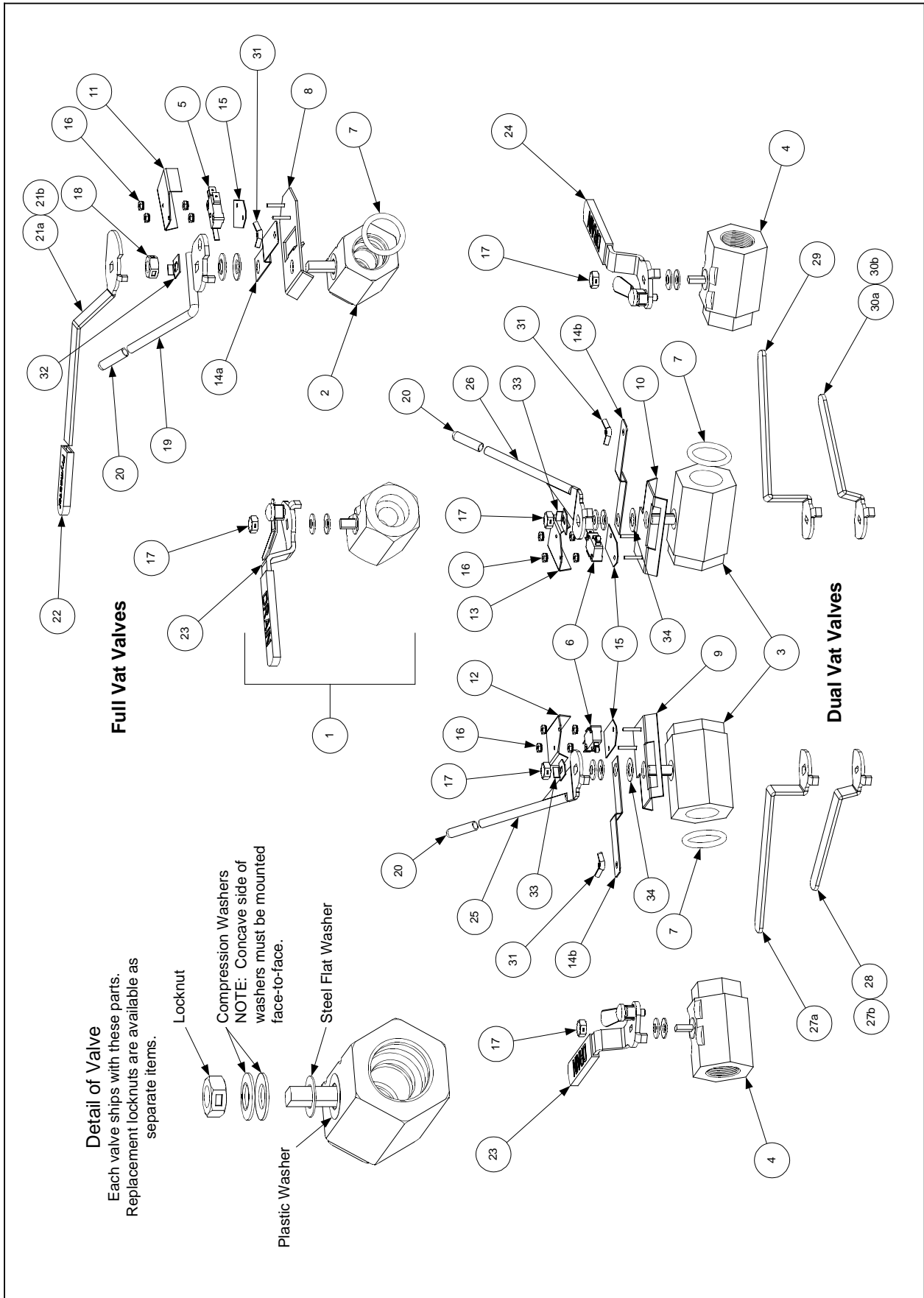

ITEM	PART #	COMPONENT
1	810-1569	Valve, Full Vat 1.25-inch Drain (for use on MH52 units. See NOTE .)
	806-7916	Valve, 1-inch Drain w/ lock Right
	806-7915	Valve, 1-inch Drain w/ lock Left
2	810-1018	Valve, Full Vat 1.25-inch Drain (for use on BIH52 units)
	806-6373SP	Valve Assembly 1.25-inch Drain
3	810-1114	Valve, Dual Vat 1-inch Drain (for use on BIH52 units)
	806-6608SP	Valve, Drain Assembly Right DV 1.25-inch
	806-6609SP	Valve, Drain Assembly Left DV 1.25-inch
	806-6400SP	Valve, Drain Assembly Left DV 1-inch
	806-6401SP	Valve, Drain Assembly Right DV 1-inch
4	810-1338	Valve, Dual Vat 1-inch Drain (for use on MH52 units)
5	807-2103	Switch, Drain Safety (for use on Full Vat BIH52 units)
6	807-2104	Switch, Drain Safety (for use on Dual Vat BIH52 units)
7	816-0135	O-Ring (for use with Items 2 and 3)
8	806-8137	Bracket, Full Vat Drain Safety Switch
9	806-8194	Bracket, Left Dual Vat Drain Safety Switch
	106-2671	Bracket, Left Dual Vat Drain Safety Switch
10	806-8195	Bracket, Right Dual Vat Drain Safety Switch
	106-2672	Bracket, Right Dual Vat Drain Safety Switch
11	900-2841	Cover, Full Vat Drain Safety Switch
12	901-2348	Cover, Left Dual Vat Drain Safety Switch
13	902-2348	Cover, Right Dual Vat Drain Safety Switch
14a	900-2354	Bracket, Full Vat Drain Valve
14b	900-2355	Bracket, Dual Vat Drain Valve
15	816-0220	Insulation, Drain Safety Switch
16	826-1366	Nut, 4-40 Keps Hex (Pkg. of 25)
17	809-0539	Nut, 3/8-inch 2-Way Lock
18	809-0540	Nut, 1/2-inch 2-Way Lock
19	900-2609	Handle, FV Drain
	210-8967	Handle, FV Drain SS
	823-2371	Handle, Non-CE Full Vat
20	810-0677	Grip, Handle Round
21a	900-2521	Handle, CE Full Vat BIH52 Drain Valve
21b	210-9179	Handle, Full Vat BIH52 Drain Valve
22	814-0047	Sleeve, Handle Flat
23	810-1568	Handle with Lock, Drain Valve (for Full or Left Dual Vat MH52 Valve)
24	810-1567	Handle with Lock, Drain Valve (for Right Dual Vat MH52 Valve)
25	201-3916	Handle, Non-CE Dual Vat BIH52 Left Drain Valve
	823-3901	Handle, Non-CE Dual Vat BIH52 Left Drain Valve non-McD's
26	200-4304	Handle, Non-CE Dual Vat BIH52 Right Drain Valve
	823-3902	Handle, Non-CE Dual Vat BIH52 Right Drain Valve non-McD's
27a	900-2509	Handle, CE Dual Vat BIH52 Left Drain Valve
27b	210-9922	Handle, Dual Vat BIH52 Left Drain Valve
28	901-5713	Handle, CE Dual Vat BIH152 Left Drain Valve
29	900-2503	Handle, CE Dual Vat BIH52 Right Drain Valve
30a	902-5713	Handle, CE Dual Vat BIH152 Right Drain Valve
30b	210-9925	Handle, Dual Vat BIH52 Right Drain Valve
31	826-1382	Wingnut (Pkg. of 10)
32	900-2936	Retainer, Drain Valve 1/2-inch Nut FV
33	900-2934	Retainer, Drain Valve 3/8-inch Nut DV
34	810-1165	Washer, Teflon DV
*	809-0196	Washer, Felt DV
*	826-1896	Bracket Kit for Dual Vat Drain Valves Left
*	826-1897	Bracket Kit for Dual Vat Drain Valves Right

* Not Illustrated

NOTE: Item 1 includes Handle, 810-1568 (Item 23).

4.5.2 Filtration System Components

4.5.2.1 Filter Base Assemblies

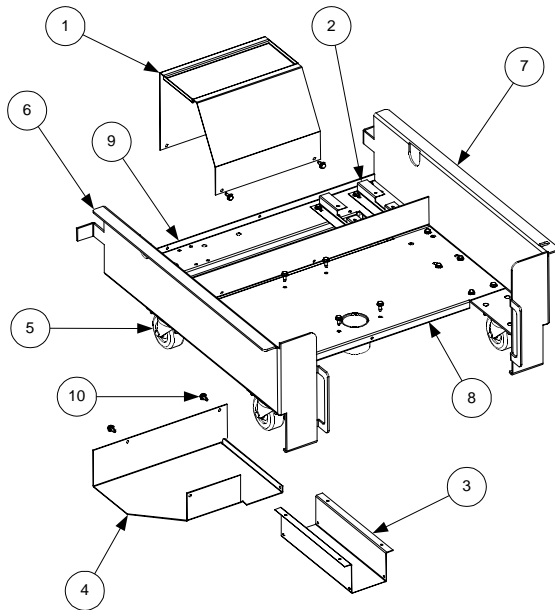

Base Assembly 106-0043SP
(Replaces Base Assembly 806-5985 used on units built prior to August 1997)

NOTE: Items 1, 2, 3, and 4 are shown assembled to base assemblies for illustrative purposes. However, **Base Assemblies 106-0043SP, 806-8804, and 806-8848SP do not include Items 1, 2, 3, and 4.** These items must be ordered separately.

Items 8 and 9 are used on all three base assemblies.

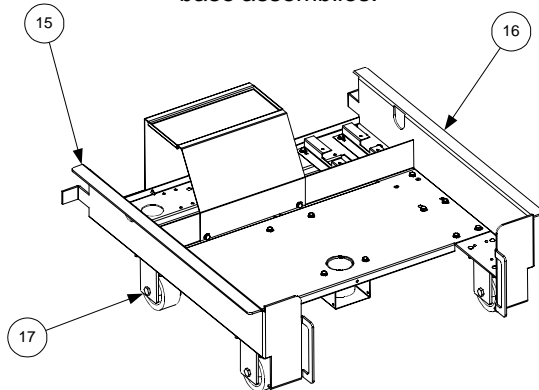

Base Assembly 806-8804
(Used on Japanese/Far East Units)

NOTE: These types of base sides are no longer available. They must be replaced with Items 13 and 14. Handles and screws used with these base sides remain available.

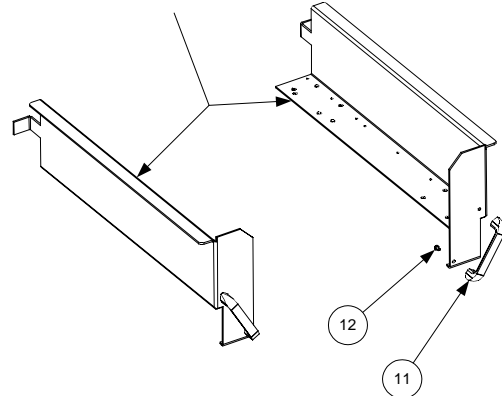

NOTE: These types of base sides are no longer available. They must be replaced with Items 13 and 14.

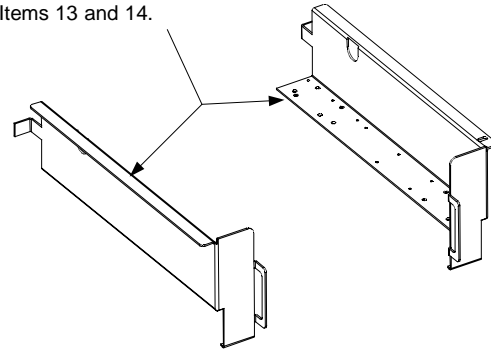

18 Lock bracket used on units built before August 1997.

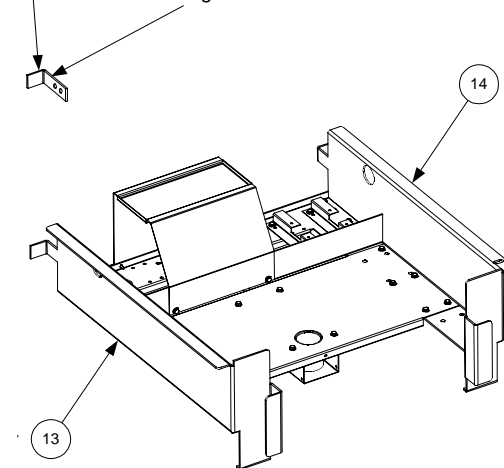

Base Assembly 806-8648SP
(Used on units built August 1997 and later.)

NOTE: In September 1999, significant changes were made to the design of the filter base assemblies used in BIH52 fryers. The most visible change was the removal of the casters on all assemblies except 806-8804 (which is used in units manufactured for sale primarily in Japan). The motor cover was also redesigned and a lower plumbing shield was added. Additionally, the two-piece motor support (P/Ns 900-7469 and 900-7470) was replaced with a single, stronger support.

In order to provide continued support for units built prior to August 1999, a new filter base assembly with casters (P/N 106-0043SP) was created to replace the original 806-5895 filter base assembly, which is no longer available.

Two additional modifications to the design of the base sides have been made since August 1999. These include the replacement of the die-cast metal handles with handles formed into the sides, and the replacement of the separate lock brackets with brackets that are also formed into the sides.

ITEM	PART #	COMPONENT
1	900-5477	Cover, Motor (September 1999 and later) (used with all three assemblies)
*	824-0558	Cover, Motor (Prior to September 1999)
2	900-1949	Standoff, Filter Wiring Box (used with all three assemblies)
3	900-7557	Cover, Suction Tube (used with all three assemblies)
4	900-9634	Shield, Filter Plumbing (used with all three assemblies)
5	810-0949	Caster, 2.5-inch Swivel (also used in original 806-5985 assembly)
6	806-9153	Side, Left Filter Base (used in 106-0043SP)
7	806-9150	Side, Right Filter Base (used in 106-0043SP)
8	823-2289	Support, Filter Pan (used in all three filter base assemblies)
9	900-5396	Support, Filter Motor (used in all three filter base assemblies)
10	826-1374	Screw, #10 x ½-inch Washer Hex Head (Pkg of 25)
11	810-0180	Handle, Plated Die-cast Metal
12	826-1360	Screw, 10-24 x 5/16-inch Round Slotted Head (Pkg of 25)
13	201-3770	Side, Left Filter Base (used in 806-8648SP)
14	202-3770	Side, Right Filter Base (used in 806-8648SP)
15	806-9154	Side, Left Filter Base (used in 806-8804SP)
16	806-9151	Side, Right Filter Base (used in 806-8804SP)
17	810-1211	Caster, BIH52 Rigid (used in 806-8804SP only)
18	900-1953	Bracket, Filter Lock (used on base assemblies prior to September 1999)
*	809-0440	Nut, 5/16-inch Keps Hex (used for securing casters to base assemblies)
*	826-1677	Pin Extension Kit

* Not illustrated.

4.5.2.2 Filter Motor and Pump Plumbing

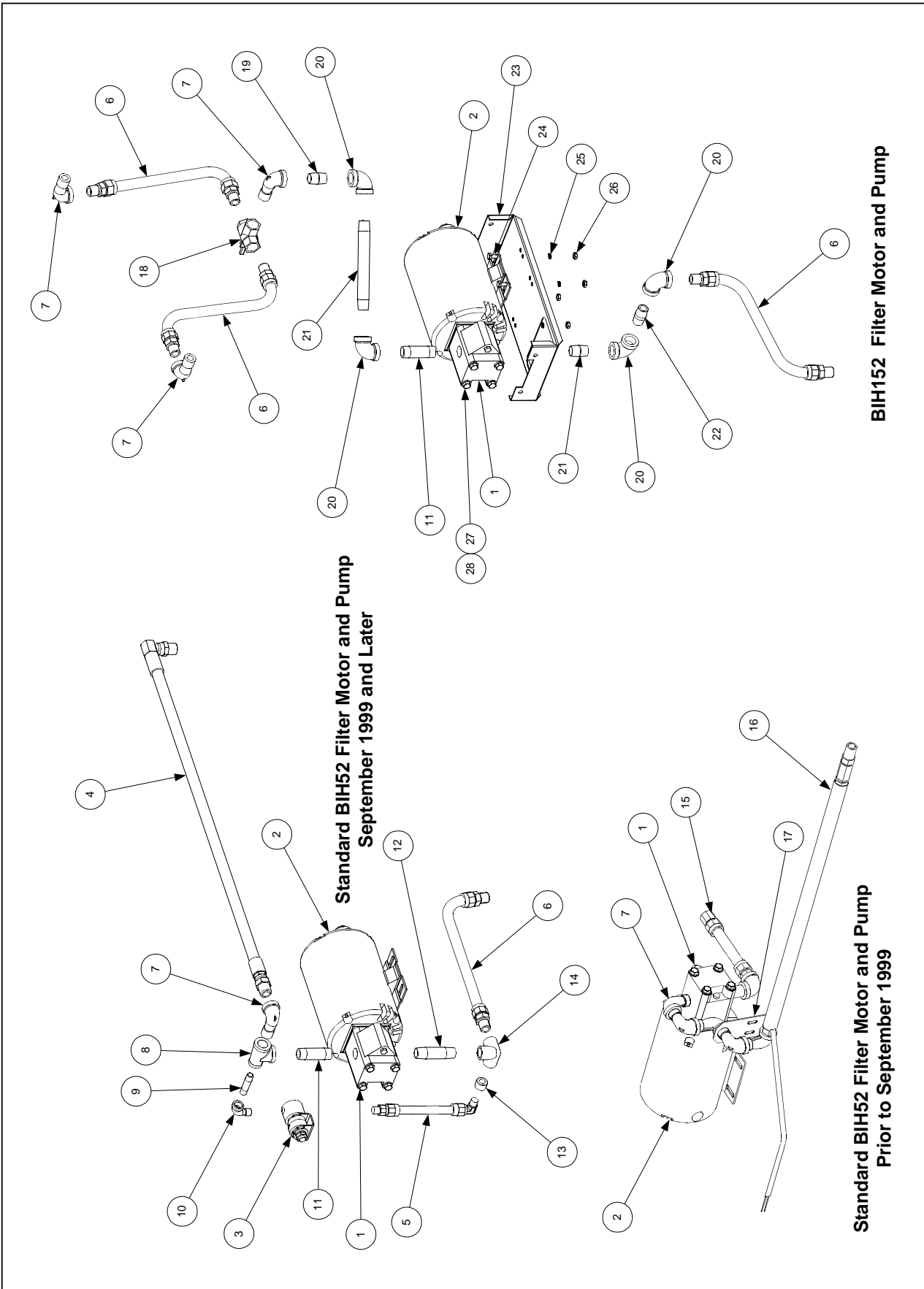

ITEM	PART #	COMPONENT
1	826-1264	Pump, 4 GPM (15 LPM) (comes with Gasket 816-0093)
2		Motor and Gasket Kit, Multi-Voltage
	826-1712	100-120VAC (replaces earlier kits 826-1260, -1263, and -1268)
	826-1713	200-250VAC (replaces earlier kits 826-1262, -1266, -1269, and -1270)
3	807-2484	Valve, Solenoid Vent
4	810-1404	Flexline, Oil Return (pump to rear manifold)
5	810-1373	Flexline, Pump Bypass
6	806-9437SP	Flexline, 15½-inch (39.5cm) Oil Return (See NOTE below)
7	813-0165	Elbow, ½-inch x 90° Street
8	813-0530	Tee, ½-inch x ¼-inch x ½-inch Reducing
9	813-0537	Nipple, ¼-inch x 2-inch
10	813-0543	Elbow, ¼-inch x 90° Street
11	813-0265	Nipple, ½-inch x 2½-inch
12	813-0460	Nipple, ½-inch x 3-inch
13	813-0304	Bushing, ½-inch to ¼-inch Reducing
14	813-0331	Elbow, ½-inch 3-way
15	810-1159	Flexline, 5-inch Oil Return
16		Hose, Heated Oil Return
	810-0945	100-120VAC
	810-1037	208-250VAC
17	900-1958	Support, Oil Return
18	810-1003	Valve, 180° 3-way Ball
19	813-0022	Nipple, ½-inch x Close
20	813-0062	Elbow, ½-inch x 90°
21	813-0098	Nipple, ½-inch x 6½-inch
22	813-0087	Nipple, ½-inch x 1½-inch
23	900-5543	Mount, Motor
24	826-1389	Screw, ¼-20 x ¾-inch Hex Head (Pkg. of 10)
25	809-0191	Washer, ¼-inch Lock
26	826-1362	Nut, ¼-20 Hex (Pkg. of 10)
27	809-0514	Capscrew 5/16"x 18 NC
28	809-0194	Washer, Flat 5/16 ZP
*	806-6728SP	Wiring Assembly, Pump Motor to Filter Box
*	816-0093	Gasket, Pump Motor
*		Thermal Switch
	807-1600	Baldor Motor, 120VAC
	807-1601	Baldor Motor, 240VAC
	807-1598	Magnatek Motor, 120VAC
	807-1599	Magnatek Motor, 240VAC
*	807-1420	Heater Tape 120V 25w 36" (Assy. 806-9245SP)
*	807-1472	Heater Tape 120V 40w 56" (Assy. 806-8004SP)
*	807-2304	Heater Tape 120V 100w 72" (Assy. 806-7755SP)
*	811-0746	Aluminum Tape – 50 yard roll
*	811-0861	Foam Insulation – by the foot

* Not illustrated.

NOTE: Item 6 consists of 13-inch Flexline 810-1057 and two ⅜-inch to ½-inch Male Adapters 810-1668, which may be ordered as separate items.

4.5.2.3 Filter Pan Assemblies and Associated Components

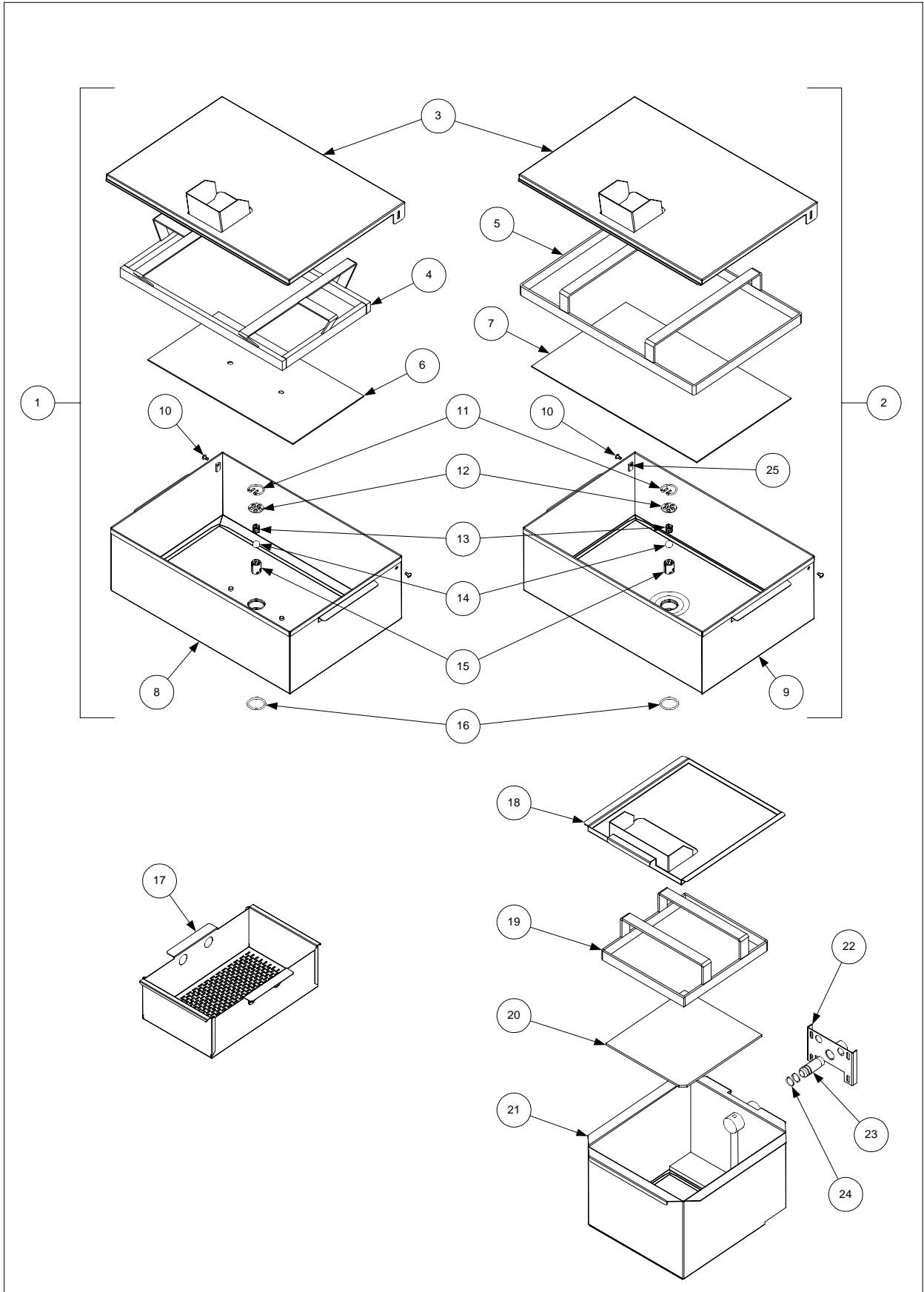

ITEM	PART #	COMPONENT
1		Pan Assembly, Filter (has screen alignment pins in pan bottom)
	806-6423SP	Standard
	806-7377SP	For use on Japanese/Far East (JBIH52) units.
2†	806-5618SP	Pan Assembly, Filter (has no screen alignment pins in pan bottom) (Paper pans used in Japan)
3		Cover, Filter Pan
	823-2027	For use with 806-6423SP and 806-5618SP assemblies.
	823-2321	For use with 806-7377SP units (has lower splash guard than 823-2027)
4	810-1405	Ring, Hold Down (for use with 806-6423SP and 806-7377SP assemblies)
5	810-1408	Ring, Hold Down (for use with 806-5618SP assembly)
6	900-8818	Screen, Sana Grid (9 x 17-inch/23 x 43cm, has alignment holes)
7	900-8819	Screen, Sana Grid (12 x 19.5-inch/30.5 x 49.5cm, has no holes)
8	823-2234SP	Pan, Filter (has screen alignment pins in pan bottom)
9†	823-1979SP	Pan, Filter (has no screen alignment pins in pan bottom)
10	809-0422	Screw, 10-32 x 7/16-inch Slotted Truss Head
	826-1490	Kit, Filter Pan Check Valve Service (consists of Items 11 through 16)
11	810-1387	Retainer, Check Valve
12	900-5448	Strainer, Check Valve
13	810-0946	Spring, Check Valve
14	810-0948	Ball, Check Valve
15	810-1388	Tube, Check Valve
16	816-0597	O-Ring, Check Valve
17	824-0430	Screen, Crumb (used with 806-5618SP, 806-6423SP, and 806-7377SP)
18	823-2586	Cover, Filter Pan (for use with 823-2575SP)
19	823-2574	Ring, Hold Down (for use in 823-2575SP)
20	900-8829	Screen, San Grid (10 x 9-inch/23 x 25cm, for use in 823-2575SP) Baby FP
21	823-2575SP	Pan, Filter (for use in BIH152 units)
22	823-2578	Bracket, BIH152 Oil Return
23	810-0697	Disconnect, Male
24	826-1392	O-Ring, BIH152 Oil Return (Pkg of 5)
25	809-0028	Nut, Wld 10-32 Sngl Wng
*	806-8550SP	Inner Pan w/ ck valve and O-rings

† Used on some early-production Japanese/Far East (JBIH52) units only.

* Not illustrated.

4.5.2.4 Rear Flush Oil Return Components

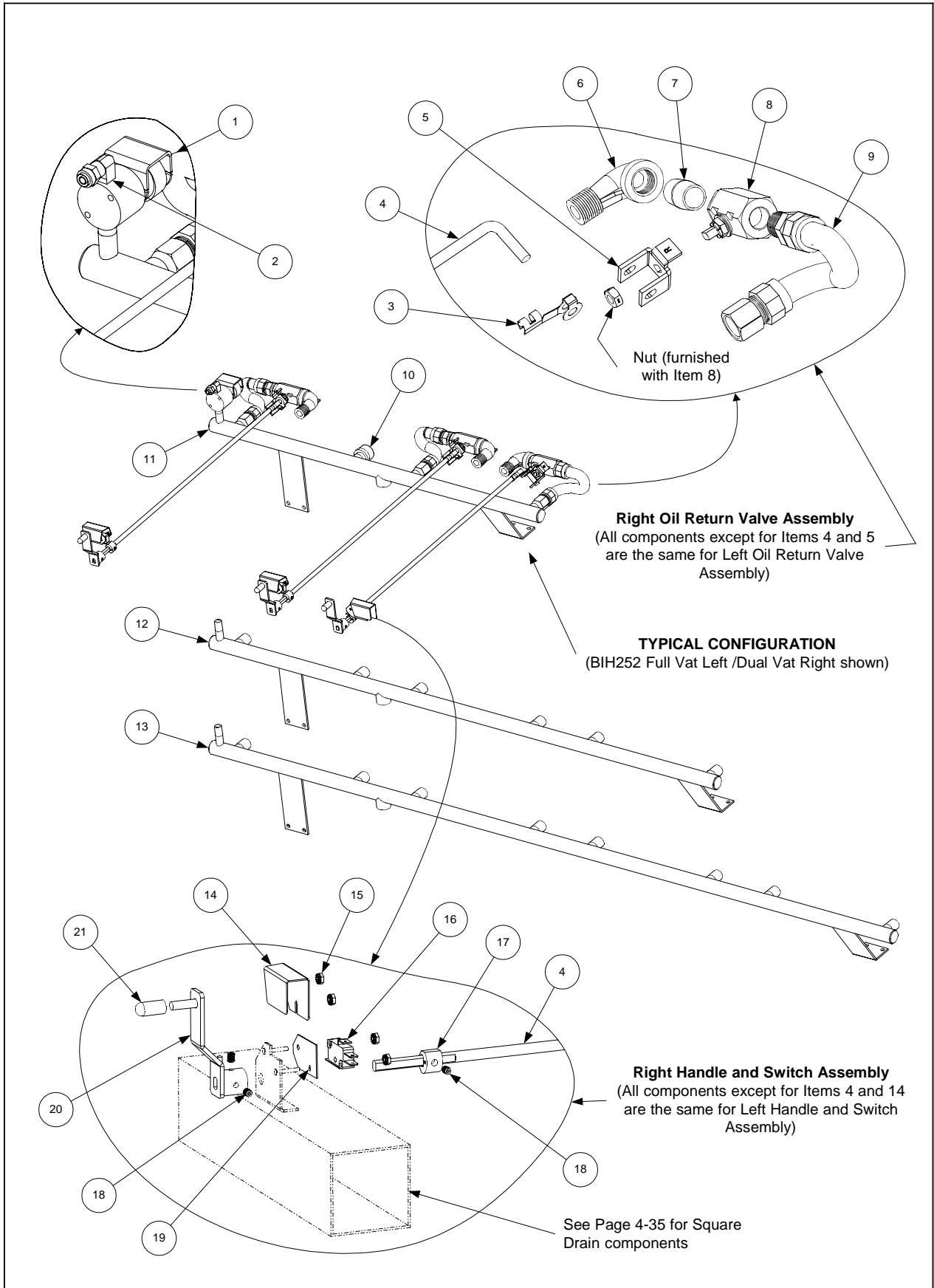

ITEM	PART #	COMPONENT
1	807-2484	Valve, Solenoid Vent (145 ohms)
2	810-1372	Elbow, 90° x ¼-inch NPT x ⅜-inch Tube
*	811-0932	Vent Tube 3/8" OD Bulk Teflon
3	809-0601	Clip, Rod End Clevis
4		Shaft, Rear Flush Valve
	810-1767	For use in left oil return valve assemblies (see illustration below). <i>FV</i>
	810-1766	For use in right oil return valve assemblies (see illustration below).
5		Handle, Rear Flush Valve
	901-2772	For use in left oil return valve assemblies. <i>FV use left only</i>
	902-2772	For use in right oil return valve assemblies.
*	900-2935	Nut, Oil Return Valve Retainer
6	813-0165	Elbow, 90° x ½-inch Street
7	813-0022	Nipple, ½-inch Close
8	810-0278	Valve, ½-inch Ball
9	806-9828SP	Flexline Assembly, 9-inch Oil Return
10	813-0469	Cap, ½-inch Pipe
11	810-1360	Manifold, BIH252 Rear Flush Oil Return
12	810-1357	Manifold, BIH352 Rear Flush Oil Return
13	810-1378	Manifold, BIH452 Rear Flush Oil Return
14		Cover, BIH52 Rear Flush Oil Return Microswitch
	901-2214	For use in left handle and switch assemblies.
	902-2214	For use in right handle and switch assemblies.
15	826-1366	Nut, 4-40 Keps Hex (Pkg. of 25)
16	807-2103	Microswitch
17	810-1186	Cam, Filter System Microswitch
18	826-1377	Setscrew, 10-32 x ¼-inch (Pkg. of 25)
19	816-0220	Insulation, Microswitch
20		Handle, Rear Flush
	823-2295	For use in Non-CE applications (see illustration below).
	823-2259	For use in CE applications only (see illustration below).
21	812-1253SP	Cover, Rear Flush Handle

NOTE: *Left* and *right* refer to the fryer as viewed from the front when facing the fryer.

