

**SERVICE MANUAL  
FRYMASTER BIPH14/MPH14 SERIES  
ELECTRIC FRYER**



This equipment chapter is to be installed in the Fryer Section of the *Equipment Manual*.

**FOR YOUR SAFETY**  
Do Not Store or use gasoline or other flammable vapors and liquids in the vicinity of this or any other appliance.

**MANUFACTURED  
BY**



**Enodis**  
One Company. Countless Solutions

**P.O. BOX 51000  
SHREVEPORT, LOUISIANA 71135-1000  
PHONE: 1-318-865-1711  
TOLL FREE: 1-800-551-8633  
1-800-24 FRYER  
FAX: 1-318-688-2200**



**TABLE OF CONTENTS**

WARRANTY STATEMENT .....	Page i
SERVICE PROCEDURES .....	Page 1-1
1.1 General .....	Page 1-1
1.2 Replacing a Computer .....	Page 1-1
1.3 Replacing Component Box Components .....	Page 1-2
1.4 Replacing a Temperature Probe or High-Limit Thermostat.....	Page 1-3
1.5 Replacing a Heating Element .....	Page 1-4
1.6 Replacing Contactor Box Components .....	Page 1-6
1.7 Replacing a Frypot.....	Page 1-7
1.8 Built-in Filtration System Service Procedures .....	Page 1-9
1.9 Interface Board Diagnostic Charts.....	Page 1-13
1.10 Wiring Diagrams .....	Page 1-14
PARTS LIST .....	Page 2-1

Frymaster L.L.C., 8700 Line Avenue 71106  
P.O. Box 51000, Shreveport, Louisiana 71135-1000  
PHONE 318-865-1711    FAX 318-219-7135  
SERVICE HOTLINE 1-800-24-FRYER

PRINTED IN THE UNITED STATES

MAY 2006

\* 8196011 \*

**NOTICE**

IF, DURING THE WARRANTY PERIOD, THE CUSTOMER USES A PART FOR THIS ENODIS EQUIPMENT OTHER THAN AN UNMODIFIED NEW OR RECYCLED PART PURCHASED DIRECTLY FROM FRYMASTER/DEAN, OR ANY OF ITS AUTHORIZED SERVICE CENTERS, AND/OR THE PART BEING USED IS MODIFIED FROM ITS ORIGINAL CONFIGURATION, THIS WARRANTY WILL BE VOID. FURTHER, FRYMASTER/DEAN AND ITS AFFILIATES WILL NOT BE LIABLE FOR ANY CLAIMS, DAMAGES OR EXPENSES INCURRED BY THE CUSTOMER WHICH ARISE DIRECTLY OR INDIRECTLY, IN WHOLE OR IN PART, DUE TO THE INSTALLATION OF ANY MODIFIED PART AND/OR PART RECEIVED FROM AN UNAUTHORIZED SERVICE CENTER.

**NOTICE**

This appliance is intended for professional use only and is to be operated by qualified personnel only. A Frymaster/Dean Factory Authorized Service Center (FASC) or other qualified professional should perform installation, maintenance, and repairs. Installation, maintenance, or repairs by unqualified personnel may void the manufacturer's warranty. See Chapter 1 of this manual for definitions of qualified personnel.

**NOTICE**

This equipment must be installed in accordance with the appropriate national and local codes of the country and/or region in which the appliance is installed. See NATIONAL CODE REQUIREMENTS in Chapter 2 of this manual for specifics.

**NOTICE TO U.S. CUSTOMERS**

This equipment is to be installed in compliance with the basic plumbing code of the Building Officials and Code Administrators International, Inc. (BOCA) and the Food Service Sanitation Manual of the U.S. Food and Drug Administration.

**NOTICE**

Drawings and photos used in this manual are intended to illustrate operational, cleaning and technical procedures and may not conform to onsite management operational procedures.

**NOTICE TO OWNERS OF UNITS EQUIPPED WITH COMPUTERS**

**U.S.**

This device complies with Part 15 of the FCC rules. Operation is subject to the following two conditions: 1) This device may not cause harmful interference, and 2) This device must accept any interference received, including interference that may cause undesired operation. While this device is a verified Class A device, it has been shown to meet the Class B limits.

**CANADA**

This digital apparatus does not exceed the Class A or B limits for radio noise emissions as set out by the ICES-003 standard of the Canadian Department of Communications.

Cet appareil numerique n'emet pas de bruits radioelectriques depassany les limites de classe A et B prescrites dans la norme NMB-003 edictee par le Ministre des Communcations du Canada.

** DANGER**

Improper installation, adjustment, maintenance or service, and unauthorized alterations or modifications can cause property damage, injury, or death. Read the installation, operating, and service instructions thoroughly before installing or servicing this equipment.

** DANGER**

The front ledge of this appliance is not a step! Do not stand on the appliance. Serious injury can result from slips or contact with the hot cooking oil/shortening.

** DANGER**

Do not store or use gasoline or other flammable liquids or vapors in the vicinity of this or any other appliance.

** DANGER**

The crumb tray in fryers equipped with a filter system must be emptied into a fireproof container at the end of frying operations each day. Some food particles can spontaneously combust if left soaking in certain shortening material.

** WARNING**

Do not bang fry baskets or other utensils on the fryer's joiner strip. The strip is present to seal the joint between the fry vessels. Banging fry baskets on the strip to dislodge shortening will distort the strip, adversely affecting its fit. It is designed for a tight fit and should only be removed for cleaning.

## **WARRANTY STATEMENT**

Frymaster, L.L.C. makes the following limited warranties to the original purchaser only for this equipment and replacement parts:

### ***A. WARRANTY PROVISIONS - FRYERS***

1. Frymaster L.L.C. warrants all components against defects in material and workmanship for a period of one year.
2. All parts, with the exception of the frypot, heating elements and fuses, are warranted for one year after installation date of fryer.
3. If any parts, except fuses, become defective during the first year after installation date, Frymaster will also pay straight-time labor costs to replace the part, plus up to 100 miles/160 km of travel (50 miles/80 km each way).

### ***B. WARRANTY PROVISIONS - FRYPOTS***

If a frypot develops a leak within seven years after installation, Frymaster will, at its option, either replace the entire battery or replace the frypot, allowing up to the maximum time per the Frymaster time allowance chart hours of straight-time labor plus up to 100 miles/160 km of travel (50 miles/80 km each way) to change the frypot.

### ***C. WARRANTY PROVISIONS - HEATING ELEMENTS***

1. Frymaster L.L.C. warrants the heating elements against defective material or workmanship for a period of three years from the original installation date, parts only.
2. This warranty does not cover ancillary components, including the hi-limit, temperature probe, and contactors.

### ***D. WARRANTY PROVISIONS - COOKING COMPUTER***

1. Frymaster L.L.C. warrants the M-2000 Cooking Computer against defective material or workmanship for a period of one year from the original installation date, parts and labor. Replacements for defective units during the second year will fall under warranty; however, labor will not. Replacements are available during the third year at a reduced rate.
2. Replacement M-2000 Cooking Computers will be warranted for the first and second years only. Replacements are available during the third year at a reduced rate. When a computer is replaced under warranty, the replaced computer carries the remaining original warranty only.
3. During this warranty period, Frymaster will, at its option, repair or replace defective cooking computer returned with new and functionally operative units.
4. For replacement of defective computers under warranty, call your local Frymaster Factory Authorized Service Center. All computers replaced under the Frymaster exchange program are covered by a one-year (parts only) warranty.

### ***E. PARTS RETURN***

All defective in-warranty parts must be returned to a Frymaster Authorized Factory Service Center within 60 days for credit. After 60 days, no credit will be allowed.

### ***F. WARRANTY EXCLUSIONS***

This warranty does not cover equipment that has been damaged due to misuse, abuse, alteration, or accident such as:

- improper or unauthorized repair (including any frypot which is welded in the field);
- failure to follow proper installation instructions and/or scheduled maintenance procedures as prescribed in your MRC cards. Proof of scheduled maintenance is required to maintain the warranty;
- improper maintenance;
- damage in shipment;
- abnormal use;
- removal, alteration, or obliteration of either the rating plate or the date code on the heating elements;
- operating the frypot without shortening or other liquid in the frypot;
- no fryer will be warranted under the seven-year program for which a proper start-up form has not been received.

This warranty also does not cover:

- transportation or travel over 100 miles/160 km (50 miles/80 km each way), or travel over two hours;
- overtime or holiday charges;
- consequential damages (the cost of repairing or replacing other property which is damaged), loss of time, profits, use or any other incidental damages of any kind.

There are no implied warranties of merchantability or fitness for any particular use or purpose.

# BIPH14/MPH14 SERIES ELECTRIC FRYERS

## CHAPTER 1: SERVICE PROCEDURES

---

### 1.1 General

Before performing any maintenance on your Frymaster fryer, disconnect the fryer from the electrical power supply.

To ensure the safe and efficient operation of the fryer and hood, the electrical plug for the 120-volt line, which powers the hood, must be fully engaged and locked in its pin and sleeve socket.

When electrical wires are disconnected, it is recommended that they be marked in such a way as to facilitate re-assembly.

### 1.2 Replacing a Computer

1. Before removing controllers from **Euro-look models** (round top-cap and drains), slide the metal bezel up to release the bottom tabs; then, remove it.
2. Remove the two screws from the upper corners of the control panel. The control panel is hinged at the bottom and will swing open from the top.

Remove screws in upper corners of control panel and swing control panel down.

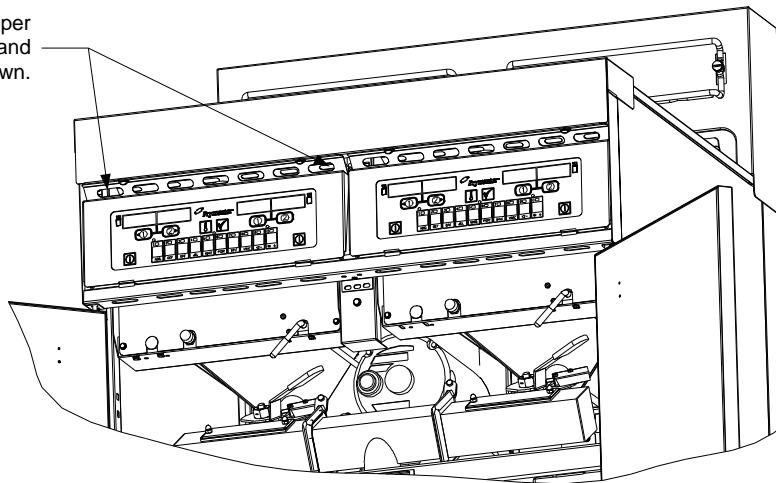

3. Unplug the wiring harness from the connector on the back of the computer and disconnect the grounding wire from terminal adjacent to the connector. Remove the control panel assembly by lifting it from the hinged slots in the control panel frame.

15-Pin Connector



Ground Wire Terminal

4. Remove the controller from the control panel assembly and install the replacement computer. Reinstall the control panel assembly by reversing steps 1 and 2.

### 1.3 Replacing Component Box Components

1. Remove the two screws from the upper corners of the control panel and allow the control panel to swing down (see steps 1 and 2 of section 1.2 on preceding page).
2. Unplug the wiring harness from the 15-pin connector on the interface board and disconnect the grounding wire from terminal adjacent to the 15-pin connector on the back of the controller. Remove the control panel assembly by lifting it from the hinge slots in the control panel frame.
3. Disconnect the wiring from the component to be replaced, being sure to make a note of where each wire was connected.

**NOTE:** If replacing the interface board, connectors J1 and J2 must also be disconnected from the 12-pin connectors on the rear of the component box, directly behind the interface board.

4. Dismount the component to be replaced and install the new component, being sure that any required spacers, insulation, washers, etc. are in place.

**NOTE:** If more room to work is required, the control panel frame and top cap assembly may be removed by removing the hex head screws that secure it to the fryer cabinet (see illustration below). If this option is chosen, all control panel assemblies must be removed per steps 1 and 2 above. The cover plate on the lower front of the component box may also be removed if desired. *Removing the component box itself from the fryer is not recommended due to the difficulty involved in disconnecting and reconnecting the oil-return valve rods, which pass through openings in the component box.*

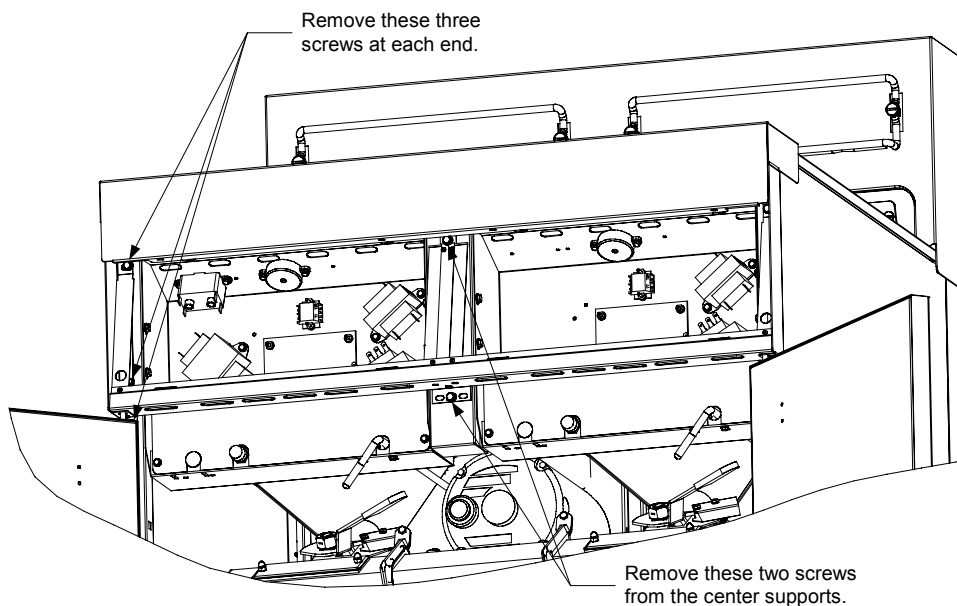

**Removing the Control Panel Frame and Top Cap Assembly**

5. Reconnect the wiring disconnected in step 3, referring to your notes and the wiring diagrams on the fryer door to ensure that the connections are properly made. Also, verify that no other wiring was disconnected accidentally during the replacement process.
6. Reverse steps 1 and 2 to complete the replacement and return the fryer to service.

#### 1.4 Replacing a Temperature Probe or High-Limit Thermostat

1. Remove the filter pan and lid from the unit. Drain the frypots into an oil disposal unit (MSDU) or other appropriate metal container.



**DO NOT drain more than one full frypot or two split frypots into the MSDU at one time.**

2. Disconnect the fryer from the electrical power supply and reposition it to gain access to the rear of the fryer.
3. Remove the tilt housing and back panels from the fryer. The tilt housing must be removed first in order to remove the upper back panel. To remove the tilt housing, raise the elements and allow them to rest on the basket support racks as shown in the photo below.



Next, remove the hex head screws from the rear edge of the housing. The housing can then be lifted straight up and off the fryer. Lift up on the upper back panel to disengage the tabs on its upper corners from the cutouts in the fryer frame.

4. Disconnect the wire harness at connector C6 and, using a pin pusher, disconnect the probe leads or high-limit leads from the connector.
5. ***If replacing a temperature probe***, remove the screw securing the probe bracket to the element and slide the bracket off the element and probe. Pull the probe out of the tilt housing assembly, install the replacement probe, and reattach the element bracket. Secure the upper portion of the probe with a replacement metal wire tie.

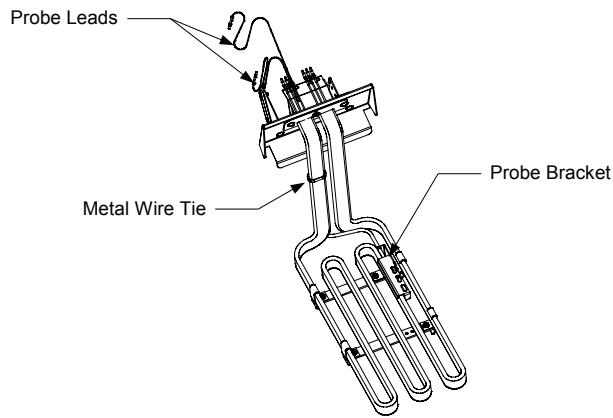

**If replacing a high-limit thermostat**, unscrew the thermostat to be replaced. Apply Loctite™ PST 567 or equivalent sealant to the threads of the replacement and screw it securely into the frypot.

6. **If a temperature probe was replaced**, insert the probe leads into the connector (see left illustration below). For full-vat units or the right half of a dual-vat unit, the red lead goes into position 6 and the white into position 7. For the left half of a dual-vat unit, the red lead goes into position 12 and the white into position 13. **NOTE:** *Right* and *left* refer to the fryer as viewed from the rear.

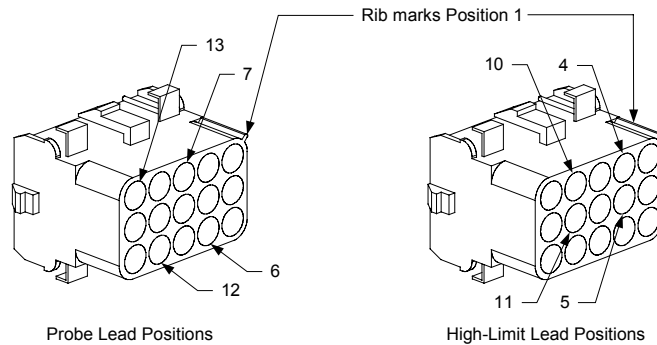

**If a high-limit thermostat was replaced**, insert the leads into the connector (see right illustration above). For full-vat units or the right half of a dual-vat unit, the leads go into positions 4 and 5 of the connector. For the left half of a dual-vat unit, the leads go into positions 10 and 11. In either case, polarity does not matter. **NOTE:** *Right* and *left* refer to the fryer as viewed from the rear.

7. Reinstall the back panels and tilt housing to complete the installation, then reverse steps 1 and 2 to return the fryer to service.

## 1.5 Replacing a Heating Element

1. Perform steps 1-3 of section 1.4, *Replacing a Temperature Probe*.
2. On dual-vat fryers, and on full-vat fryers where the temperature probe is attached to the element being replaced, disconnect the wire harness containing the probe wiring (connector C6). Using a pin pusher, disconnect the probe wires from the connector.



- On the front of the contactor box, disconnect the 6-pin connector for the left element (as viewed from the front of the fryer) or the 9-pin connector for the right element and pull the harness out through the rear of the fryer. Press in on the tabs on each side of the connector while pulling outward on the free end to extend the connector and release the element leads (see photo below). Pull the leads out of the connector and out of the plastic wire loom.

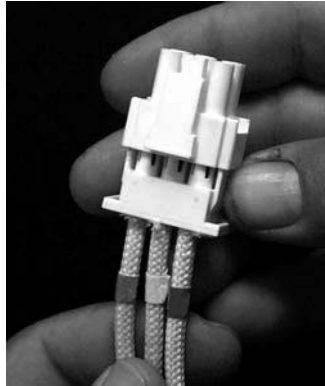

- Raise the element to the full up position and disconnect the element springs.
- Remove the nuts and machine screws that secure the element to the tilt plate assembly and pull the element out of the frypot. **NOTE:** Full-vat elements consist of two dual-vat elements clamped together. For full-vat units, remove the element clamps before removing the nuts and machine screws that secure the element to the tilt plate assembly.
- If applicable, recover the probe bracket and probe from the element being replaced and install them on the replacement element, then install the replacement element in the frypot, securing it with the nuts and screws removed in Step 5.
- Route the element leads through the wire loom to prevent chafing and press the pins into the connector in accordance with the diagram below, then close the connector to lock the leads in place.

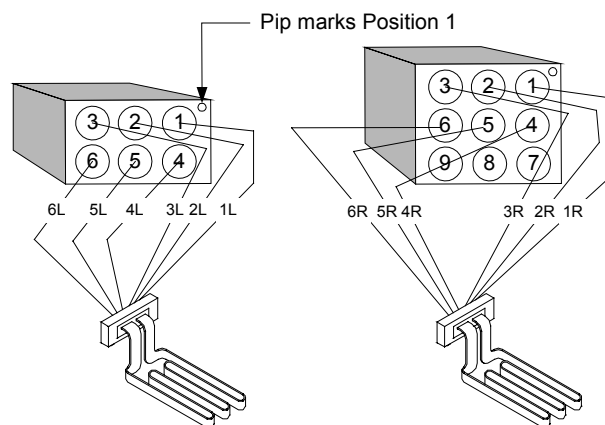

- Insert the element connector into the receptacle on the front of the contactor box, ensuring that the latches lock.
- If disconnected in step 2, insert the temperature probe leads into the wiring harness connector (see illustration below). For full-vat units or the right half of a dual-vat unit, the red lead goes

into position 6 and the white into position 7. For the left half of a dual-vat unit, the red lead goes into position 12 and the white into position 13. **NOTE:** *Right* and *left* refer to the fryer as viewed from the rear.

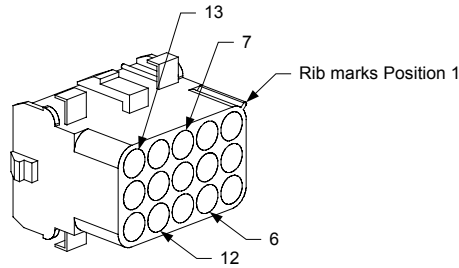

10. If disconnected in step 2, reconnect connector C6 of the wiring harness.
11. Reconnect the element springs and lower the element back down onto the basket rack.
12. Reinstall the tilt housing and back panels, reposition the fryer under the exhaust hood, and reconnect it to the electrical power supply.

## 1.6 Replacing Contactor Box Components

1. Remove the filter pan and lid from the unit. Drain the frypots into an oil disposal unit (MSDU) or other appropriate metal container.

### DANGER

**DO NOT drain more than one full frypot or two split frypots into the MSDU at one time.**

2. Disconnect the fryer from the electrical power supply.
3. Unplug the wiring harnesses from the contactor box to be serviced.
4. Remove the two screws that secure the box in place. **NOTE:** If you remove the screws from both boxes at the same time, the boxes will jam against each other and neither can be removed.

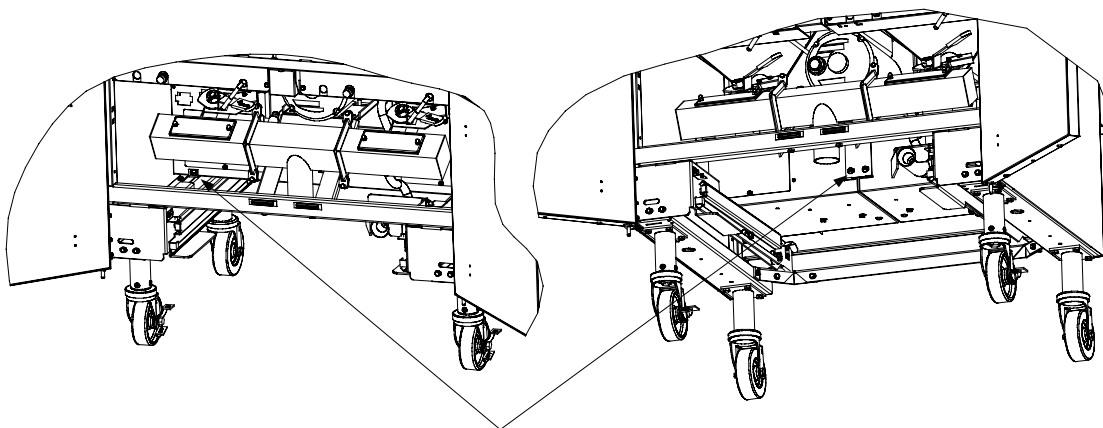

Remove these screws to dismount the left contactor box.  
The right contactor box is secured in a similar manner.

5. Carefully lower the box to the floor and pull it out the front of the fryer. Remove the top cover to access contactors and other components.
6. After performing necessary service, reverse steps 1-5 to return the fryer to operation.

## 1.7 Replacing a Frypot

1. Remove the filter pan and lid from the unit. Drain the frypots into an oil disposal unit (MSDU) or other appropriate metal container.



**DO NOT drain more than one full frypot or two split frypots into the MSDU at one time.**

2. Disconnect the fryer from the electrical power supply and reposition it to gain access to both the front and rear.
3. On **Euro-look models**, slide the metal bezel up to release the bottom tabs; then, remove it.
4. On **all** models, remove the two screws from the upper corners of the control panels and allow them to swing down (see illustration and photo on page 1-1).
5. Unplug the wiring harnesses and ground wires from the backs of the controllers. Remove the controllers by lifting them from the hinge slots in the control panel frame.
6. Remove the tilt housing and back panels from the fryer. The tilt housing must be removed first in order to remove the upper back panel. To remove the tilt housing, raise the elements and allow them to rest on the basket support racks (see photo on page 1-3).

Next, remove the hex head screws from the rear edge of the housing. The housing can then be lifted straight up and off the fryer. Lift up on the upper back panel to disengage the tabs on its upper corners from the cutouts in the fryer frame.

7. Dismount the top cap by removing the hex head screws at each end that secure it to the control panel frame.
8. Remove the hex head screw that secures the front of the frypot to the cabinet cross brace.
9. Remove the top-connecting strip that covers the joint with the adjacent frypot.
10. On **standard models**, unscrew the Teflon vent/vacuum-breaker tube fitting, open the drain tube cleanout covers, unscrew the retainer nuts from the drain valve nipples, and remove the tube assembly from the fryer.

On **Euro-look models**, unscrew the Teflon vent/vacuum-breaker tube fitting, unscrew the nut located on the front of each section of drain tube, and remove the tube assembly from the fryer.

11. Remove the covers from the drain safety switch(es) and disconnect the switch wiring at the switch(es).

12. At the rear of the fryer, unplug the C6 connector and, using a pin pusher, disconnect the high-limit thermostat leads.
13. Disconnect the oil return flexline(s) at the frypot end(s).
14. Raise the elements to the full up position and disconnect the element springs.
15. Remove the machine screws and nuts that secure the tilt plate and element assembly to the frypot. Carefully lift the tilt plate and element assembly from the frypot and secure it to the cross brace on the rear of the fryer with wire ties or tape.
16. Carefully lift the frypot from the fryer and place it upside down on a stable work surface.
17. Recover the drain valve(s), oil return flexline connection fitting(s), and high-limit thermostat(s) from the frypot. Apply Loctite™ PST 567 or equivalent sealant to the threads of the recovered parts and install them in the replacement frypot.
18. Carefully lower the replacement frypot into the fryer. Reinstall the hex head screw removed in step 7 to attach the frypot to the fryer.
19. Position the tilt housing and element assembly in the frypot and reinstall the machine screws and nuts removed in step 14.
20. Reconnect the oil return flexlines to the frypot, and replace aluminum tape, if necessary, to secure heater strips to the flexlines.
21. Insert the high-limit thermostat leads disconnected in step 11 (see illustration on page 1-4 for pin positions).
22. Reconnect the drain safety switch wiring to the switch(es) in accordance with the diagram below then reinstall the switch covers.

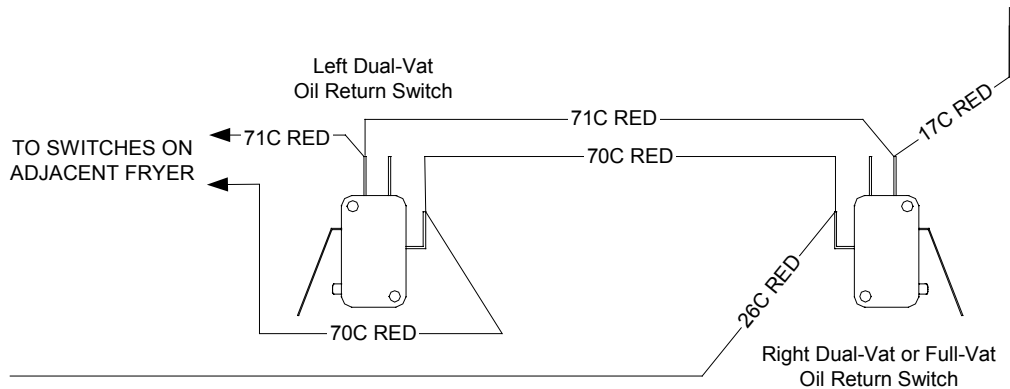

23. Reinstall the drain tube assembly.
24. Reinstall the tilt housing and back panels, top cap, and top connecting strip.
25. Reinstall controllers in the control panel frame and reconnect the wiring harnesses and ground wires.
26. Reposition the fryer under the exhaust hood and reconnect it to the electrical power supply.

## 1.8 Built-in Filtration System Service Procedures

### 1.8.1 Filtration System Problem Resolution

One of the most common causes of filtration problems is placing the filter paper on the bottom of the filter pan rather than over the filter screen.

#### CAUTION

**Ensure that filter screen is in place prior to filter paper placement and filter pump operation. Improper screen placement is the primary cause of filtration system malfunction.**

Whenever the complaint is “the pump is running, but no oil is being filtered,” check the installation of the filter paper, and ensure that the correct size is being used. While you are checking the filter paper, verify that the O-ring on the bottom of the filter pan is present and in good condition. A missing or worn O-ring allows the pump to take in air and decreases its efficiency. Also, oil leaks on the floor each time a vat is drained.

If the pump motor overheats, the thermal overload will trip and the motor will not start until it is reset. If the pump motor does not start, press the red reset switch (button) located on the rear of the motor.

If the pump starts after resetting the thermal overload switch, then something is causing the motor to overheat. A major cause of overheating is when several frypots are filtered sequentially, thus overheating the pump and motor. Allow the pump motor to cool at least 30 minutes before resuming operation. Pump overheating can be caused by:

- Solidified shortening in the pan or filter lines, or
- Attempting to filter unheated oil or shortening (cold oil and shortening are more viscous, overloading the pump motor and causing it to overheat).

If the motor runs but the pump does not, there is a blockage in the pump. Incorrectly sized or installed paper/pads will allow food particles and sediment to pass through the filter pan and into the pump. When sediment enters the pump, the gears bind, causing the motor to overload, again tripping the thermal overload. Shortening that has solidified in the pump will also cause it to seize, with the same result.

A pump seized by debris or hard shortening can usually be freed by manually moving the gears with a screwdriver or other instrument.

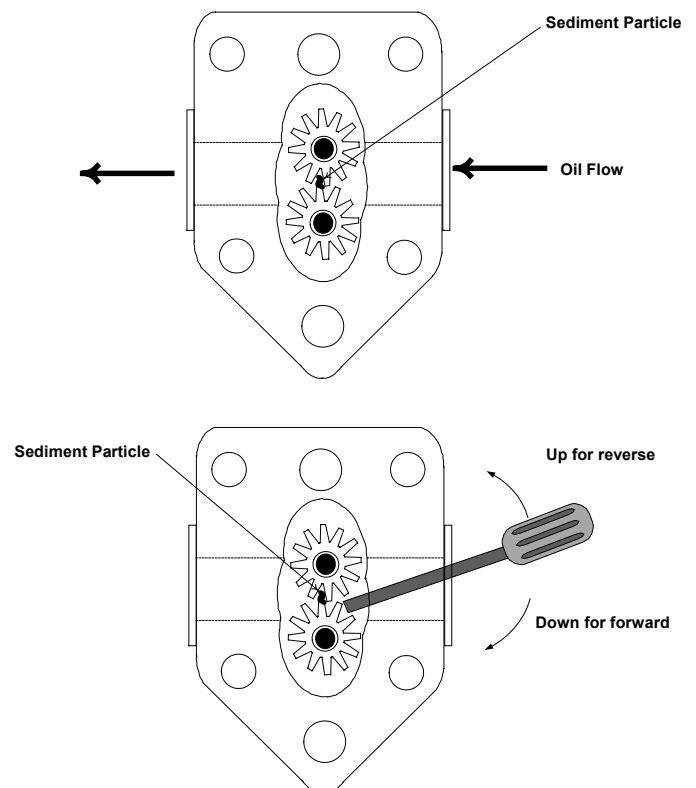

Disconnect power to the filter system, remove the input plumbing from the pump, and use a screwdriver to manually turn the gears.

- Turning the pump gears in reverse will release a hard particle.
- Turning the pump gears forward will push softer objects and solid shortening through the pump and allow free movement of the gears.

Incorrectly sized or installed paper/pads will also allow food particles and sediment to pass through and clog the suction tube on the bottom of the filter pan. Particles large enough to block the suction tube may indicate that the crumb tray is not being used. Pan blockage can also occur if shortening is left in the pan and allowed to solidify. Blockage removal can be accomplished by forcing the item out with an auger or drain snake. Compressed air or other pressurized gases should not be used to force out the blockage.

### 1.8.2 Replacing the Filter Motor, Filter Pump, and Related Components

1. Remove the filter pan and lid from the unit. Drain the frypots into an oil disposal unit (MSDU) or other appropriate metal container.

**! DANGER**

**DO NOT drain more than one full frypot or two split frypots into the MSDU at one time.**

2. Disconnect the fryer from the electrical power supply and reposition it to gain access to both the front and rear.
3. Remove the two lower back panels, unplug the wiring harnesses from the contactor boxes, and remove the two screws that secure one of the boxes in place (it doesn't matter which one; see illustration on page 1-6). **NOTE:** If you remove the screws from both boxes at the same time, the boxes will jam against each other and neither can be removed.
4. Carefully lower the box to the floor and pull it out the front of the fryer. Remove the remaining box following the same procedure.
5. Disconnect the two flexlines running to the oil-return manifold at the rear of the fryer. Remove the nut and bolt that secures the bridge to the oil-return manifold.

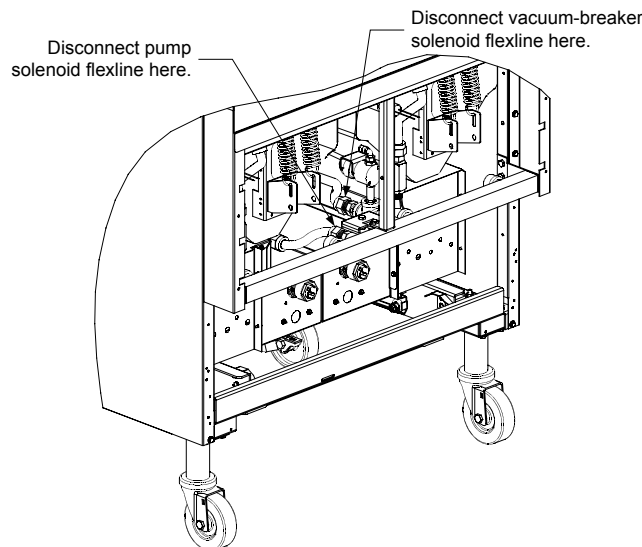

6. Disconnect the pump suction flexline at the filter pan connection end.

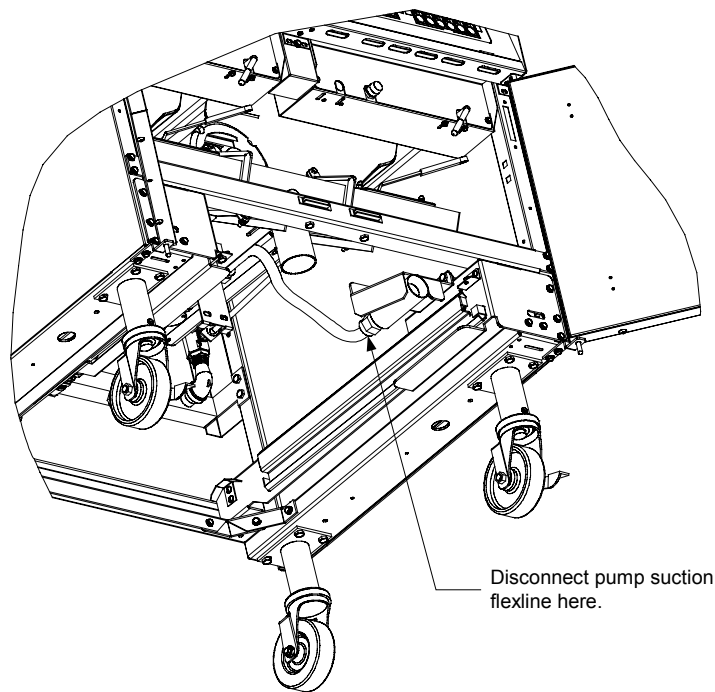

7. Remove the cover plate from the front of the motor and disconnect the motor wires.
8. Unplug the 15-pin connector from the rear of the left component box and, using a pin pusher, disconnect the solenoid valve wires (pins 4, 6, 10 and 12). **NOTE:** If the vacuum-breaker solenoid valve is connected to the manifold rather than the pump, its wires (pins 4 and 6) do not need to be disconnected.
9. Remove the two nuts and bolts that secure the front of the bridge to the cross brace and carefully slide the bridge rearward off the cross brace until its front end can be lowered to the floor. Be careful not to let the rear of the bridge slip off the manifold at this point. **NOTE:** In some early production units, the bridge will not slide far enough to the rear to clear the front brace. In such cases, the front brace must be removed. It is held in place by two hex head screws on each end and a nut and bolt inside the brace near each end.
10. Get a good grip on the bridge, carefully pull it forward off the oil-return manifold, and lower the entire assembly to the floor. Once on the floor, pull the assembly out the front of the fryer.
11. When required service has been completed, reverse steps 6-12 to reinstall the bridge. **NOTE:** The black motor wires go on the top terminal, the white on the bottom. The pump solenoid valve wires go in positions 10 and 12 of the 15-pin connector; the vacuum-breaker solenoid valve wires go in positions 4 and 6. In both cases, polarity does not matter.
12. Once the bridge is back in place, reverse steps 4 and 5 to reinstall the contactor boxes.
13. Reconnect the unit to the electrical power supply, and verify that the pump is functioning correctly (i.e., when a filter handle is placed in the ON position, the motor should start and there should be strong suction at the intake fitting and outflow at the power shower or rear flush port).

14. When proper operation has been verified, reinstall the back panels and the filter pan and lid, and return the fryer to service.

### 1.8.3 Replacing the Filter Transformer or Filter Relay

Remove the left controller from the fryer to expose the interior of the left component box. The filter transformer and relay are located as shown in the illustration below. **NOTE:** The right component box is identical to the left except that the filter transformer and relay are not present.

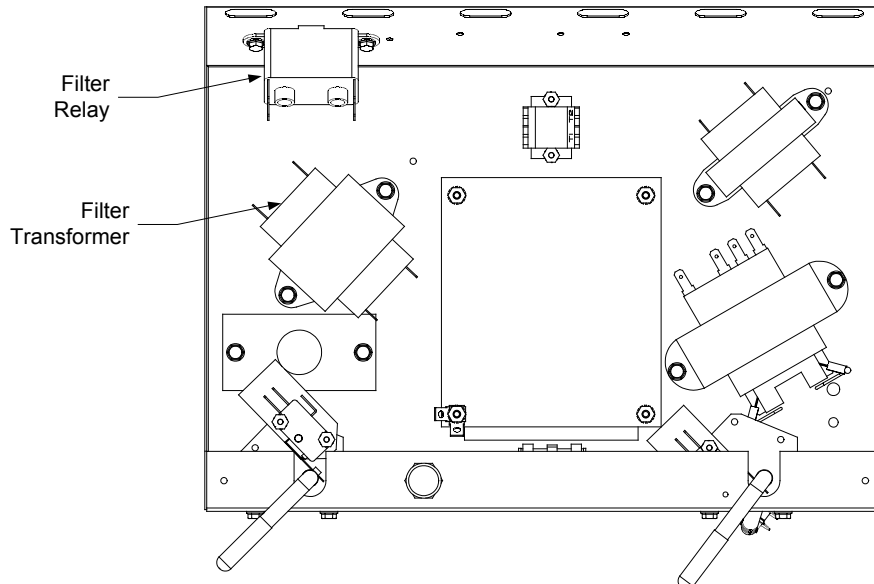

Dual-vat configuration illustrated. In full-vat units, left filter handle is not present.



## 1.9 Interface Board Diagnostic Chart

The following diagram and charts provide ten quick system checks that can be performed using only a multimeter.

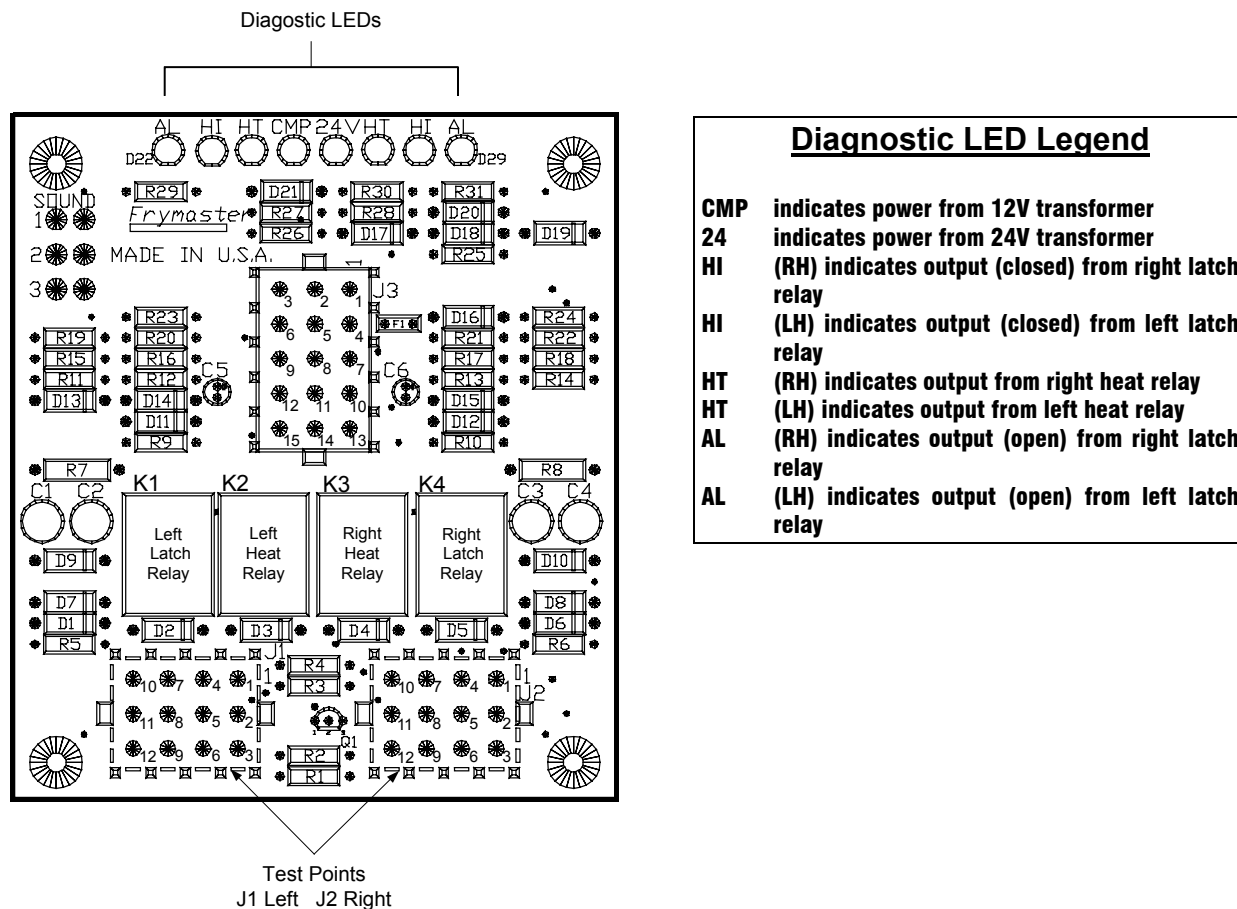

Meter Setting	Test	Pin	Pin	Results
12 VAC Power	50 VAC Scale	1 of J2	3 of J2	12-16 VAC
24 VAC Power	50 VAC Scale	2 of J2	Chassis	24-30 VAC
*Probe Resistance (RH)	R X 1000 OHMS	11 of J2	12 of J2	See Chart
*Probe Resistance (LH)	R X 1000 OHMS	3 of J1	2 of J1	See Chart
Hi-Limit Continuity (RH)	R X 1 OHMS	7 of J2	4 of J2	0 - OHMS
Hi-Limit Continuity (LH)	R X 1 OHMS	4 of J1	7 of J1	0 - OHMS
Latch Contactor Coil (RH)	R X 1 OHMS	8 of J2	Chassis	3-10 OHMS
Latch Contactor Coil (LH)	R X 1 OHMS	5 of J1	Chassis	3-10 OHMS
Heat Contactor Coil (RH)	R X 1 OHMS	9 of J2	Chassis	18-25 OHMS
Heat Contactor Coil (LH)	R X 1 OHMS	6 of J1	Chassis	18-25 OHMS

\* Disconnect 15-Pin harness from the computer/controller before testing the probe circuit.



# CONTACTOR BOX – DELTA CONFIGURATION

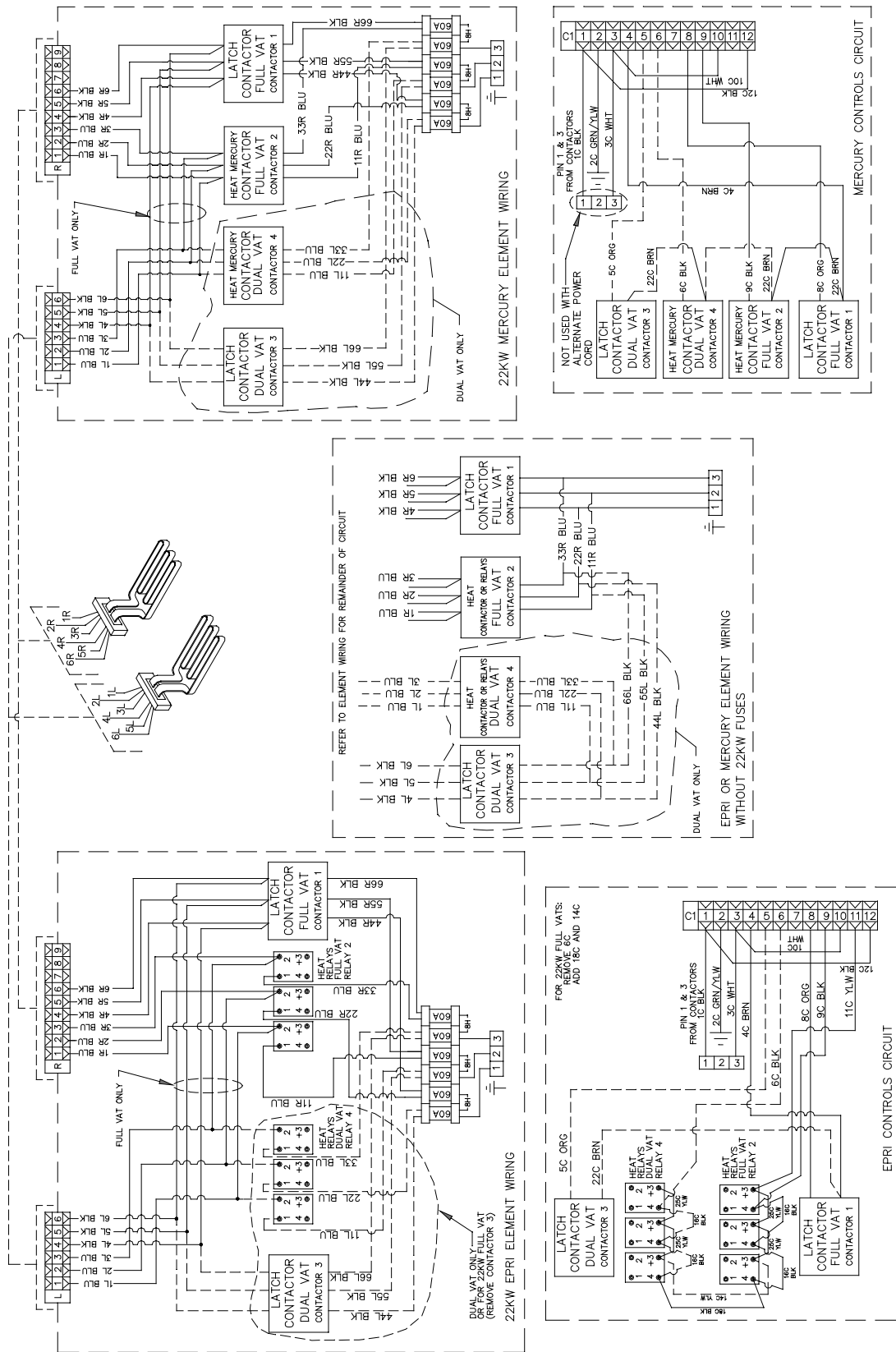

8051395B

# CONTACTOR BOX – WYE CONFIGURATION

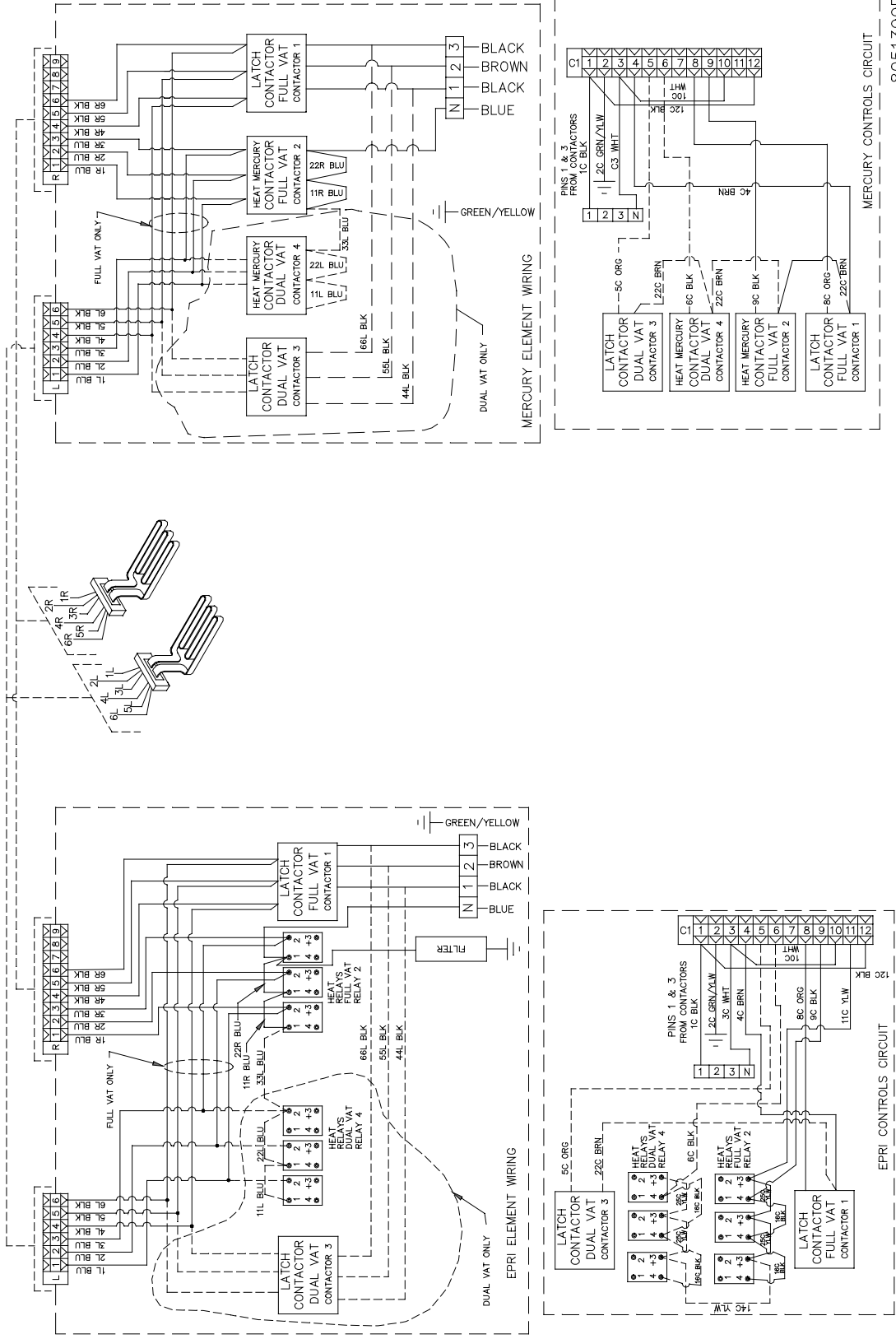

8051399B

# BIPH14/MPH14 SERIES ELECTRIC FRYERS

## CHAPTER 2: PARTS LIST

### 2.1 Accessories

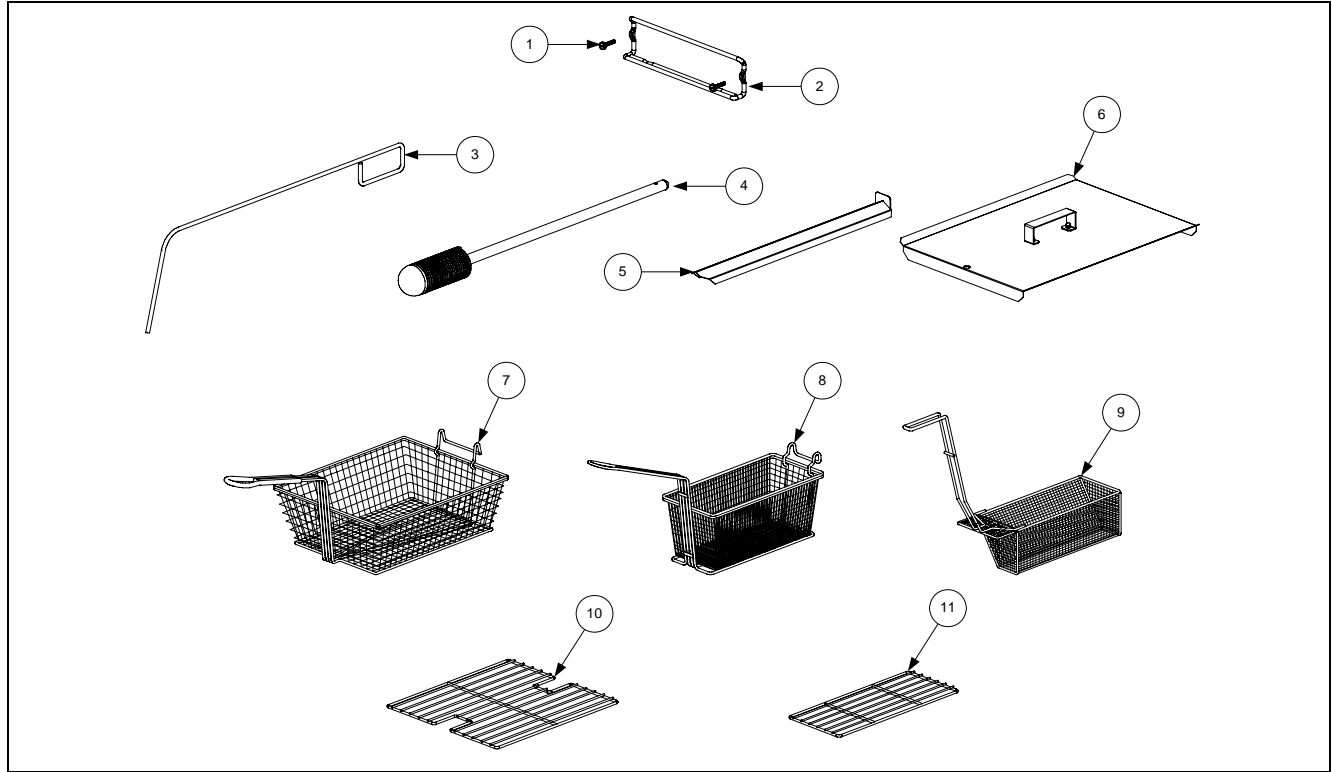

ITEM	STANDARD PART #	EUROLOOK PART #	COMPONENT
1	809-0171		Thumbscrew, 1/4 -20 X 1 <sup>3</sup> / <sub>8</sub> -inch
2	810-1403		Hanger, Wireform Basket
*	809-0921		Spacer, Basket Hanger
3	803-0197		Cleanout Rod, 27-inch
4	803-0209		Brush, Frypot
5	823-1885		Connecting Strip, Frypot
6	806-3068		Cover, Full-Vat Frypot
*	806-3071		Cover, Dual-Vat Frypot
7	803-0099		Basket, Full-Vat
8	803-0271		Basket, Dual-Vat (Twin)
9	803-0122		Sediment Tray, Left Dual-Vat
*	803-0123		Sediment Tray, Right Dual-Vat
*	803-0113		Sediment Tray, Full-Vat
10	803-0132		Rack, Full-Vat Basket Support
11	803-0106		Rack, Dual-Vat Basket Support
*	803-0002		Powder, Filter (80 1-Cup Applications)
*	803-0046		Cup, Plastic Measuring
*	803-0170		Pack, 100-Sheet Filter Paper

\* Not illustrated.

■ Use standard part.

## 2.2 Cabinetry

### 2.2.1 Back Panels, Control Panel Frames, Doors, Sides, Tilt Housings, and Top Caps

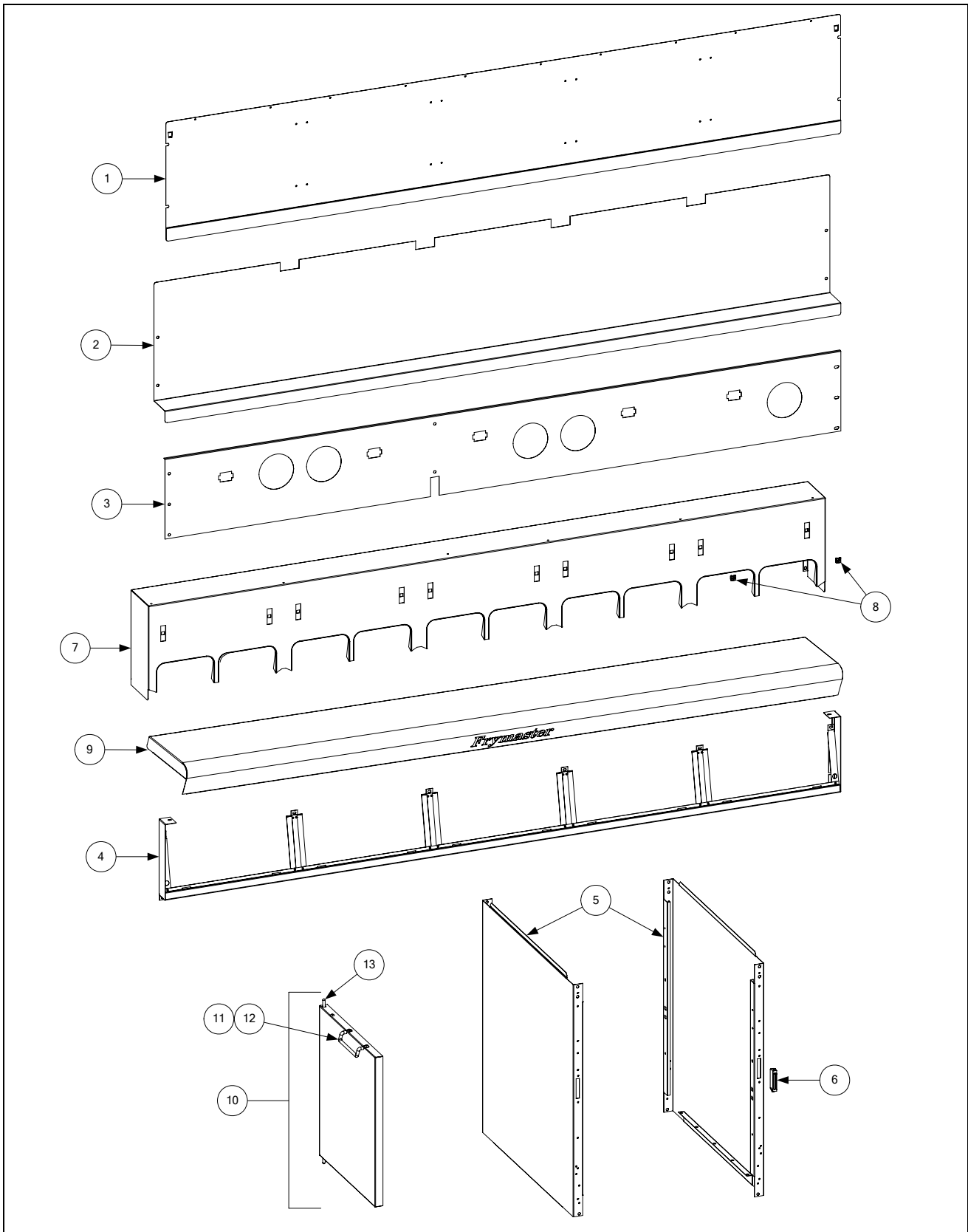

ITEM	STANDARD PART #	EURO-LOOK PART #	COMPONENT
1			Back Panel, Upper (Panel for five station fryer shown)
	200-2299	200-6630	Two Station Fryer
	200-2380	200-6785	Three Station Fryer
	200-3490	200-6786	Four Station Fryer
	200-3670	200-6787	Five Station Fryer
2			Back Panel, Center (Panel for five station fryer shown)
	200-2298		Two Station Fryer
	200-2379		Three Station Fryer
	200-3489		Four Station Fryer
	200-3669		Five Station Fryer
3			Back Panel, Lower (Panel for five station fryer shown)
	200-4430	200-4426	Two Station Fryer
	200-4431	200-4427	Three Station Fryer
	200-4432	200-4428	Four Station Fryer
	200-4433	200-4429	Five Station Fryer
4			Frame, Control Panel (Frame for five station fryer shown)
	806-7172SP	106-4378	Two Station Fryer ( <i>use 106-5221SP for fryers mfd. After 6.22.05</i> )
	806-7173SP	106-4391	Three Station Fryer ( <i>use 106-5018SP for fryers mfd. After 6.22.05</i> )
	806-7174SP	106-4392	Four Station Fryer ( <i>use 106-5019 for fryers mfd. After 6.22.05</i> )
	806-9776SP	106-4393	Five Station Fryer ( <i>use 106-5020 for fryers mfd. After 6.22.05</i> )
5	210-4435		Side, Standard Cabinet Left or Right
6	810-2346		Magnet, Door
7			Tilt Housing (Housing for five station fryer shown)
	824-1061	824-1303	Two Station, S/S
	824-1057	824-1327	Two Station, Aluminized Steel
	824-1062	824-1335	Three Station, S/S
	824-1058	824-1338	Three Station, Aluminized Steel
	824-1063	824-1336	Four Station, S/S
	824-1059	824-1339	Four Station, Aluminized Steel
	824-1064	824-1337	Five Station, S/S
	824-1060	824-1340	Five Station, Aluminized Steel
8	826-1351	809-0015	Nut Retainer, ¼-20 (Pkg. of 10 – receives basket hanger thumbscrew)
9			Top Cap (Top cap for five station fryer shown) ( <i>Also requires 809-0078 Nutserts</i> )
	824-0869	106-4436	Two Station ( <i>use 106-5196 for fryers mfd. After 6.22.05</i> )
	824-0870	106-4438	Three Station ( <i>use 106-5197 for fryers mfd. After 6.22.05</i> )
	824-0871	106-4440	Four Station ( <i>use 106-5198 for fryers mfd. After 6.22.05</i> )
	824-0872	106-4442	Five Station ( <i>use 106-5199 for fryers mfd. After 6.22.05</i> )
			Cap-N-Splash
*	823-3074		Two Station
*	823-3075		Three Station
*	823-3077		Four Station
*	823-3076		Five Station
10	806-6545SP	106-4397	Door, Left or Right (Left shown – move handle to bottom for right)
11	809-0266		Screw, #10 X ½-inch Phillips Truss Head
12	810-1422	210-6816	Handle, Wireform Door
13	106-0554		Pin Assembly, Door
*	810-0275		Spring, Door Pin
*	824-0532		Housing, MAC114 HE Tilt with cap/splash
*	824-0534		Housing, MAC214 HE Tilt with cap/splash
*	824-0535		Housing, MAC314 HE Tilt with cap/splash
*	824-0536		Housing, MAC414 HE Tilt with cap/splash

\* Not illustrated.

Use standard part.

## 2.2.2 Cabinet Bases, Braces, and Associated Parts

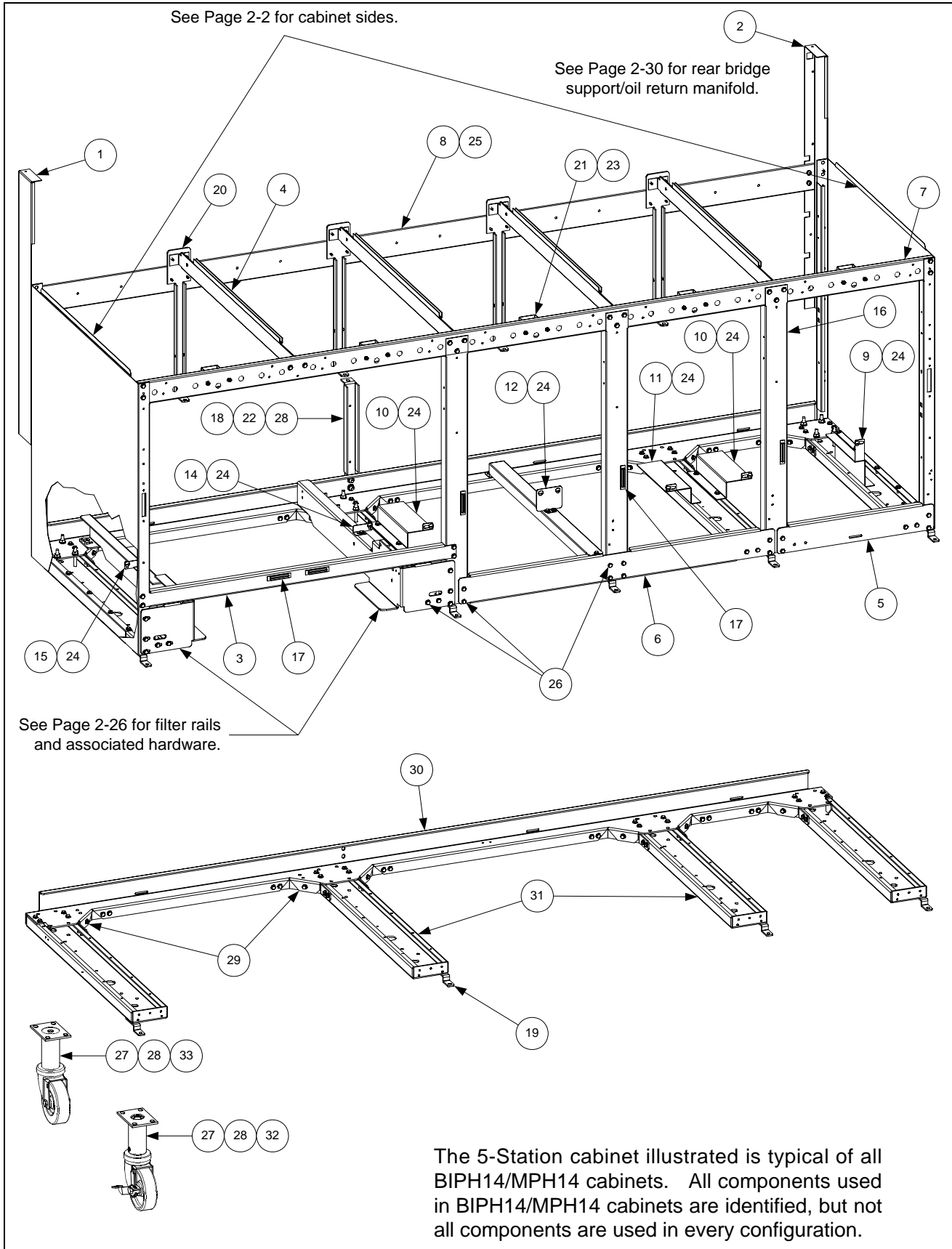



ITEM	STANDARD PART #	EURO-LOOK PART #	COMPONENT
1	106-1265SP		Upright Assembly, Left
2	106-1266SP		Upright Assembly, Right
3	200-1651		Support, Cross Cabinet
4	200-1659		Divider, Cabinet
5	200-2293		Brace, Single Station Lower
6	200-3774		Brace, Double Station Lower
7			Brace, Front Horizontal
	200-2331		Two-Station Fryer
	200-2296		Three-Station Fryer
	200-2733		Four-Station Fryer
	200-3590		Five-Station Fryer
8			Brace, Rear Horizontal
	200-2284		Two-Station Fryer
	200-2295		Three-Station Fryer
	200-2725		Four-Station Fryer
	200-3592		Five-Station Fryer
9	200-4422		Support, Contactor Box Right Station 3 or Station 5
10	201-4425		Support, Contactor Box Left Station 4 or Station 5
11	202-4425		Support, Contactor Box Right Station 3
12	200-4423		Support, Contactor Box Stations 3 and 4
13	200-4447		Support, Contactor Box Front to Rear
14	201-5369		Support, Contactor Box Station 2
15	202-5369		Support, Contactor Box Station 1
16	200-4424		Post, Door
17	810-2346		Magnet, Door
18	200-4786		Support, Oil Return Manifold
19	210-5595		Hinge, Door
20	210-1490		Bracket, Rear Support
21	900-1224		Bracket, Frypot
22	809-0131		Bolt, 1/4-20 X 3/4-inch Hex Head <i>(also used w/Item 27 to mount filter rails)</i>
23	826-1371		Screw, #8 X 1/2-inch Drill Point Hex Head (Pkg. of 25)
24	826-1330		Screw, 10-32 X 3/8-inch Slotted (Pkg. of 25, used to attach contactor box)
25	809-0256		Nut, 10-32 Keps Hex
26	809-0412		Screw, #10 X 1/2-inch Hex Washer Head (primary cabinet screw)
27	809-0417		Nut, 1/4-20 Hex Flange
28	809-0429		Bolt, 1/4-20 X 2-inch Hex Head
29	200-5417		Brace, Rear Channel Corner
30			Channel, Base Rear
	200-5463		Two-Station Fryer
	200-5538		Three-Station Fryer
	200-5537		Four-Station Fryer
	200-5536		Five-Station Fryer
31	824-1131		Channel, Base Side
32	810-0326		Caster with Brake
33	810-0327		Caster without Brake

Use standard part.

## 2.3 Drain System Components

### 2.3.1 Drain Tube Sections and Associated Parts

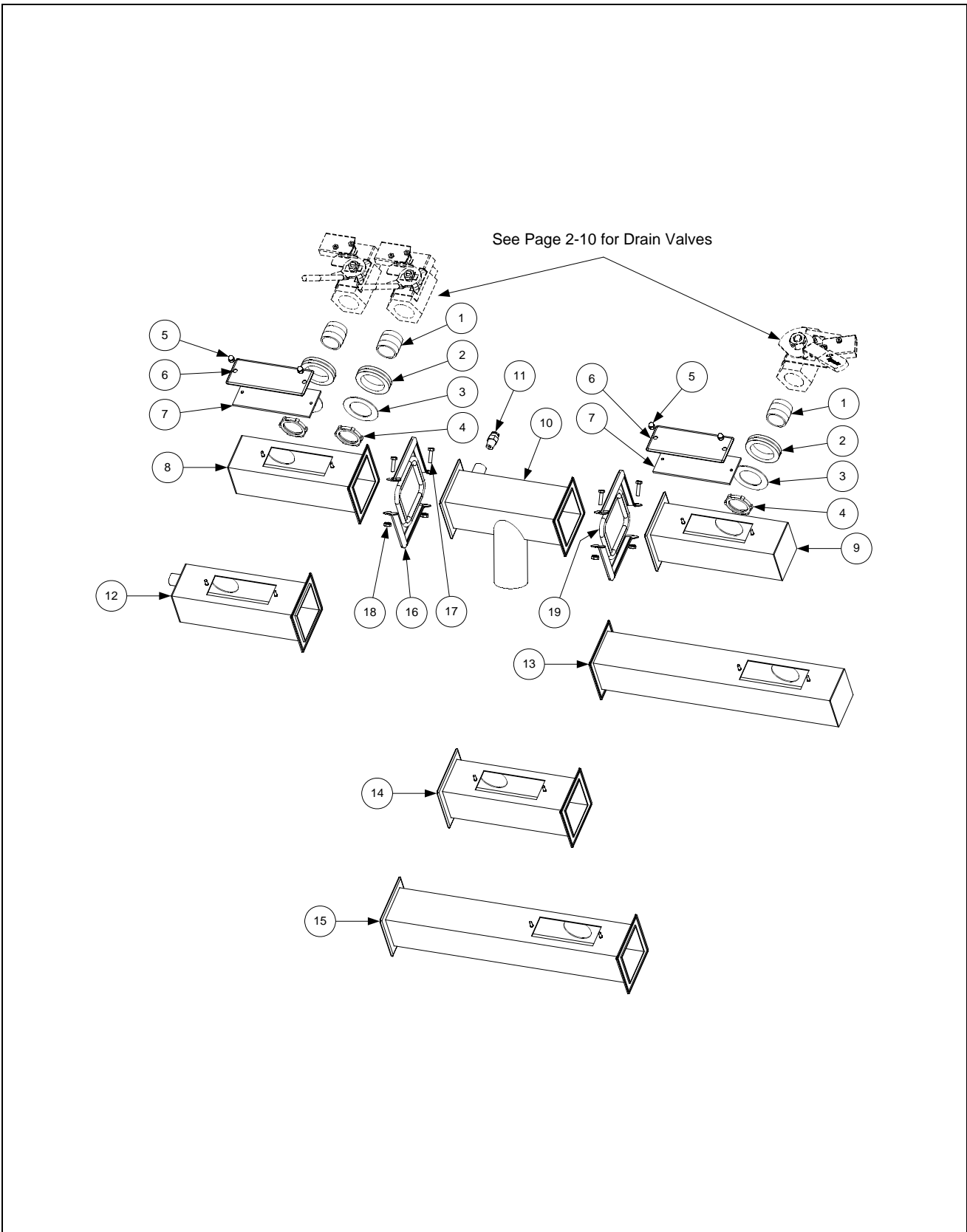

ITEM	STANDARD PART # **	COMPONENT
1	813-0284	Nipple, 3/4 X 1-inch NPT
2	816-0092	Grommet, 1-inch Drain
3	826-1345	Washer, 1-inch Drain (Pkg. of 25)
4	809-0347	Nut, 1-inch NPT Retainer
5	809-0893	Nut, 8-32 High Crown Acorn
6	826-1348	Cover, Drain Cleanout (Pkg. of 5)
7	816-0021	Gasket, Drain Cleanout
8		Drain Tube, Left End Short
	823-3380	Full-Vat
	823-3379	Dual-Vat
9		Drain Tube, Right End Short
	823-1549	Full-Vat
	823-1551	Dual-Vat
10		Drain Outlet
	823-3229	With Vacuum Breaker Vent
	823-2336	Without Vacuum Breaker Vent
11	810-2492	Fitting, Quick-Connect Straight (receives Teflon vent tube)
12		Drain Tube, Left End Short Vented
	823-2637	Full-Vat
	823-2636	Dual-Vat
13		Drain Tube, Right End Long
	823-1508	Full-Vat
	823-1543	Dual-Vat
14		Drain Tube, Open End Short
	823-0718	Full-Vat
	823-0725	Dual-Vat
15		Drain Tube, Open End Long
	823-0717	Full-Vat
	823-0724	Dual-Vat
16	810-0396	Clamp, Square Drain
17	809-0401	Screw, 10-32 X 3/4-inch Hex Head
18	809-0256	Nut, 10-32 Keps Hex
19	816-0032	Gasket, Square Drain
*	826-0877	Kit, Square Drain Clamp (2 each of Items 16-18 and 1 of Item 19)
*	811-1071	Tube, Teflon Vent

\* Not illustrated.

\*\* See page 2-9 for an *Euro-Look* parts list.

### 2.3.2 Euro-Look Drain Tube and Associated Parts

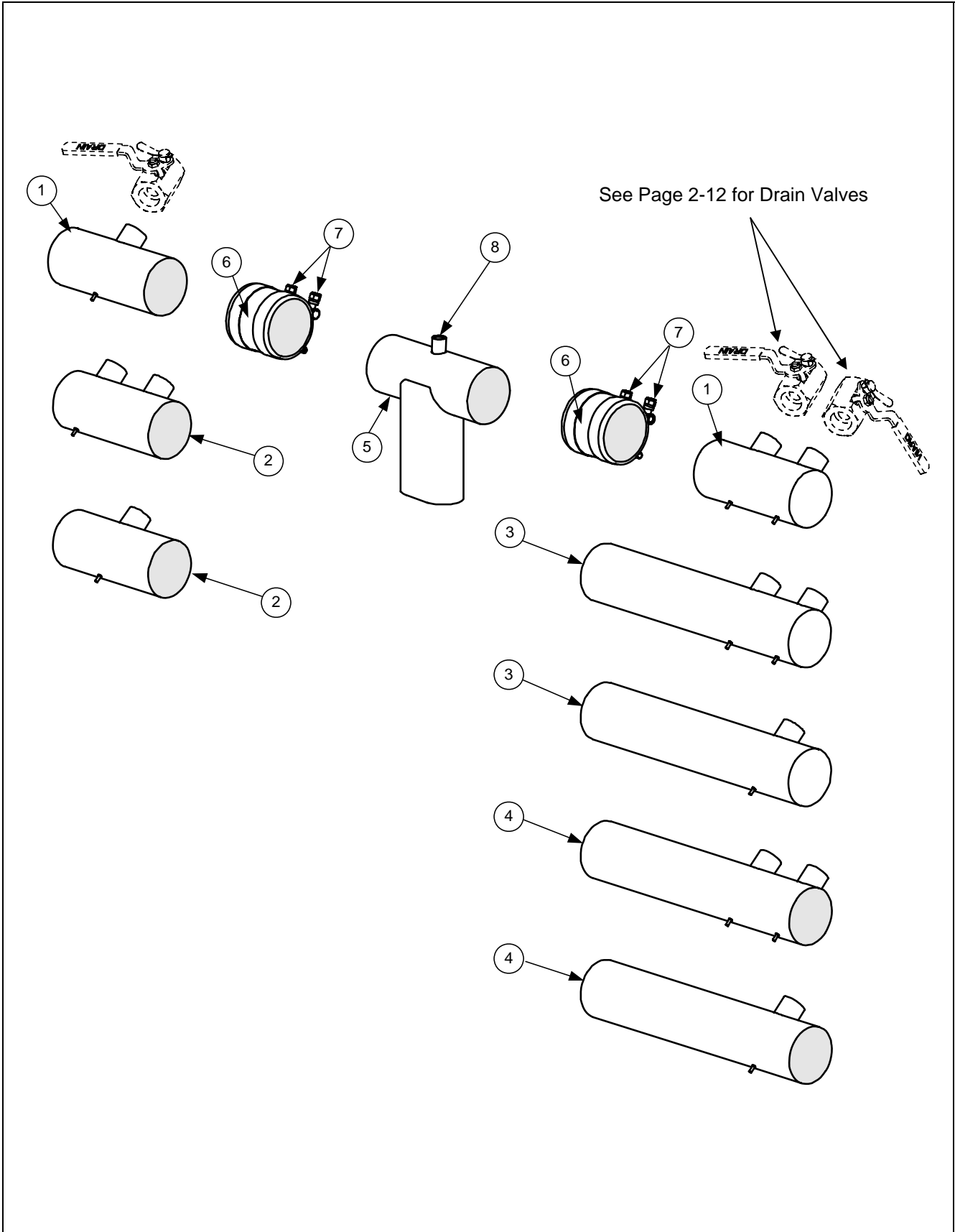

<b>ITEM</b>	<b>EURO-LOOK PART# **</b>	<b>COMPONENT</b>
1		Drain Tube, Left/Right End Short
	823-4625	Full-Vat
	823-4624	Dual-Vat
2		Drain Tube, Left/Right Open Short
	823-4643	Full-Vat
	823-4642	Dual-Vat
3		Drain Tube, Right End Long
	823-4639	Full-Vat
	823-4638	Dual-Vat
4		Drain Tube, Left/Right Open Long
	823-4641	Full-Vat
	823-4640	Dual-Vat
5	823-4892	Drain Outlet
6	816-0625	Sleeve
7	809-0969	Clamp
8	810-2492	Fitting, Quick-Connect Straight (receives Teflon vent tube)
*	KIT6033	Kit, Round Drain Clamp (2 or Item 7 and 1 of Item 6)
*	811-1071	Tube, Teflon Vent

\* Not illustrated.

\*\* See page 2-7 for a standard parts list.

### 2.3.3 Drain Valves and Associated Parts (Units with Built-In Filtration)

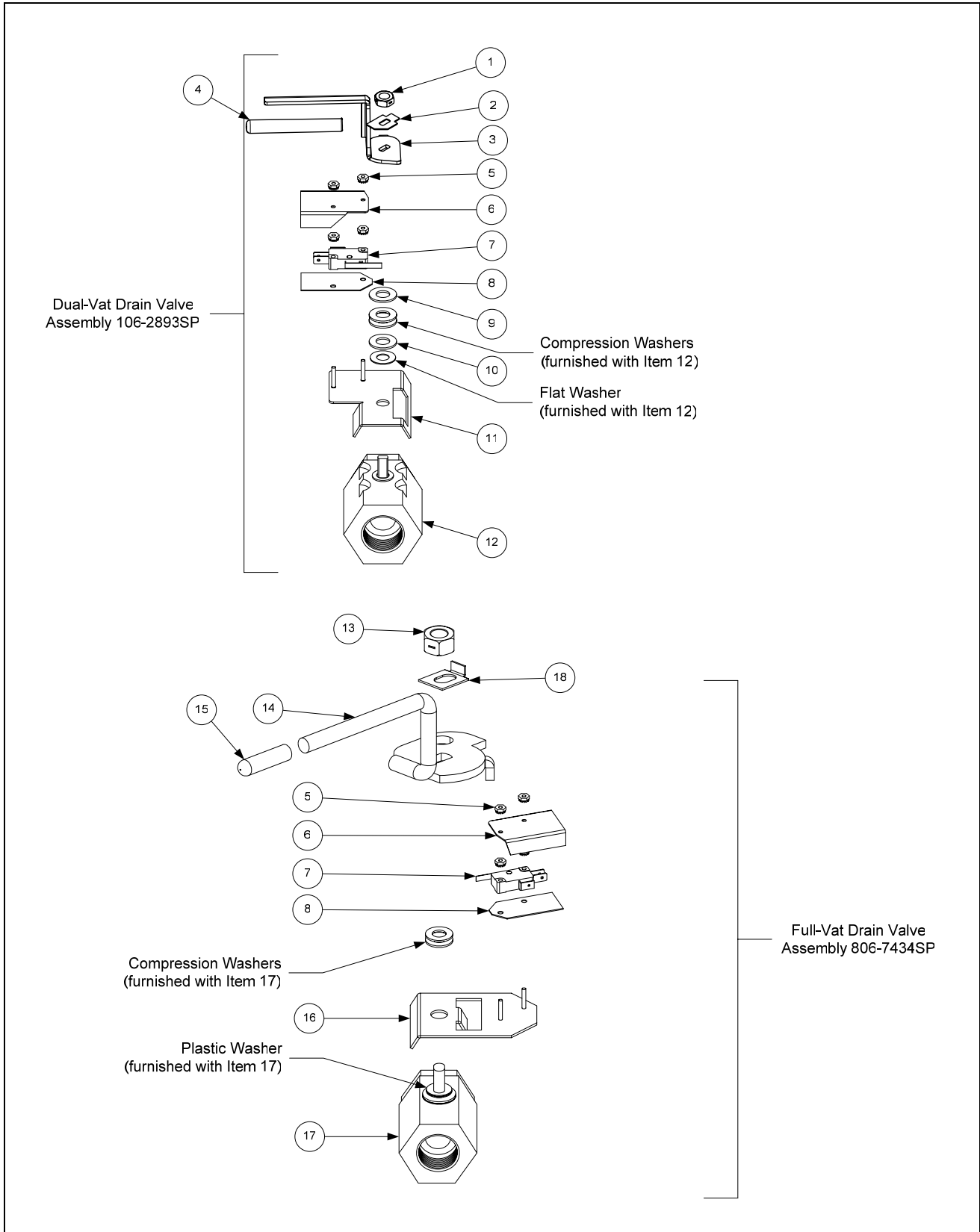

<b>ITEM</b>	<b>STANDARD PART # **</b>	<b>COMPONENT</b>
1	809-0539	Nut, 3/8-16 2-Way Hex Lock
2	900-2934	Retainer, Dual-Vat Drain Valve Nut
3	823-4133	Handle, Dual-Vat Drain Valve
4	810-0677	Grip, Drain Handle
5	809-0237	Nut, 4-40 Keps Hex
6	901-2348	Cover, Dual Vat Drain Safety Switch
7	807-2103	Microswitch, CE Straight Lever
8	816-0220	Insulation, Drain Safety Switch
9	810-1165	Washer, Teflon Drain Valve
10	809-0196	Washer, 3/8-inch Flat
11	106-2671SP	Bracket Assembly, Dual-Vat Drain Safety Switch
12	810-1338	Valve, 1-inch Dual-Vat Drain
13	809-0540	Nut, 1/2-13 2-Way Hex Lock
14	824-1602	Handle, Full-Vat Drain Valve
15	816-0639	Cap, Red Handle
16	806-8137SP	Bracket Assembly, Full-Vat Drain Safety Switch
17	810-1020	Valve, 1.25-inch Full-Vat Drain
*	WIR0572	Wire Bundle, Drain Safety Switch

\* Not illustrated.

\*\* See page 2-13 for an *Euro-Look* parts list.

### 2.3.4 Euro-Look Drain Valves and Associated Parts (Units with Built-In Filtration)

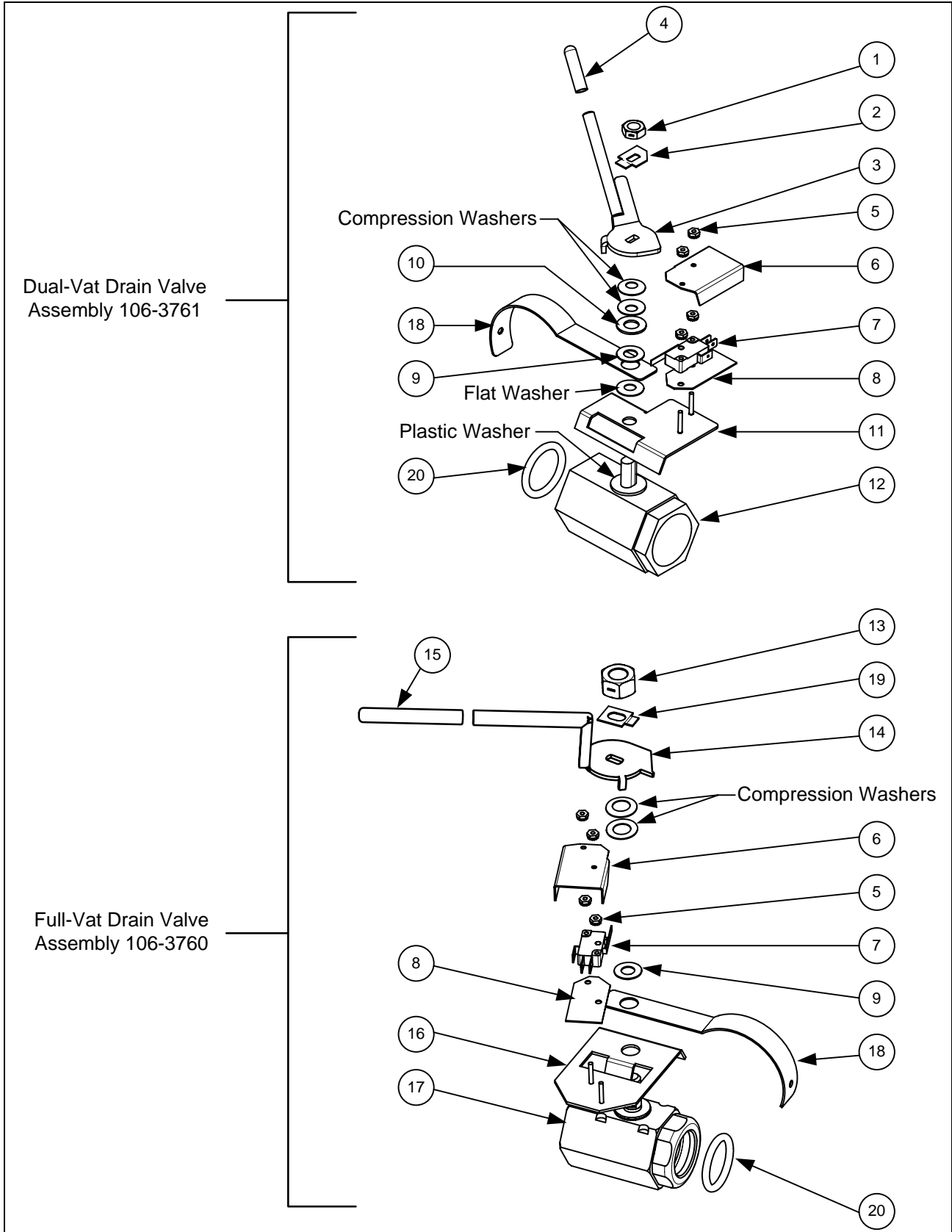



ITEM	EURO-LOOK PART # **	COMPONENT
1	809-0539	Nut, 3/8-16 2-Way Hex Lock
2	900-2934	Retainer, Dual-Vat Drain Valve Nut
3	823-4133	Handle, Dual-Vat Drain Valve
4	810-0677	Grip, Drain Handle
5	809-0237	Nut, 4-40 Keps Hex
6	901-2348	Cover, Dual Vat Drain Safety Switch
7	807-2103	Microswitch, CE Straight Lever
8	816-0220	Insulation, Drain Safety Switch
9	810-1165	Washer, Teflon Drain Valve
10	809-0196	Washer, 3/8-inch Flat
11	106-2671	Bracket Assembly, Dual-Vat Drain Safety Switch
12	810-1114	Valve, 1-inch Dual-Vat Drain
13	809-0540	Nut, 1/2-13 2-Way Hex Lock
14	824-1602	Handle, Full-Vat Drain Valve
15	816-0639	Sleeve, Red Handle
16	806-8137	Bracket Assembly, Full-Vat Drain Safety Switch
17	810-1018	Valve, 1.25-inch Full-Vat Drain
18	200-6496	Support, 3" Drain
19	900-2936	Retainer, Full-Vat Drain Valve Nut
20	816-0135	Round Drain O-Ring
*	WIR0572	Wire Bundle, Drain Safety Switch

\*Not illustrated.

\*\* See page 2-11 for a standard parts list.

### 2.3.5 Drain Valves and Associated Parts (Units without Built-In Filtration)

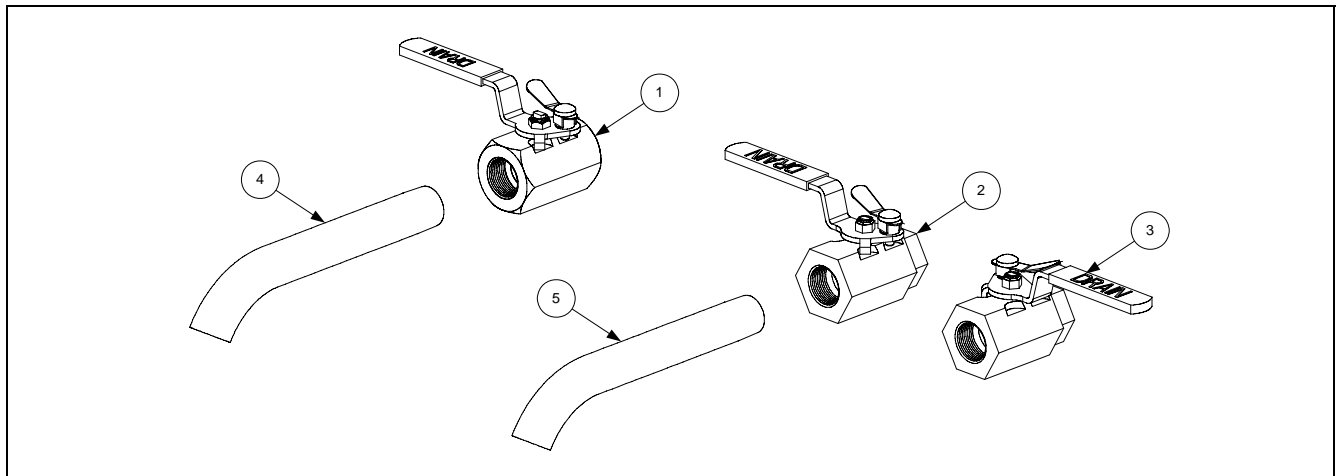

ITEM	STANDARD PART #	EURO-LOOK PART #	COMPONENT
1	810-1569		Valve, 1.25-inch Non-Filter Full-Vat Drain
2	806-7915SP		Valve, 1-inch Non-Filter Dual-Vat Left Drain
3	806-7916SP		Valve, 1-inch Non-Filter Dual-Vat Right Drain
4	812-1226		Drain Extension, 1.25-inch
5	812-1227		Drain Extension, 1-inch

■ Use standard part.

## 2.4 Electronics and Wiring Components

### 2.4.1 Component Boxes

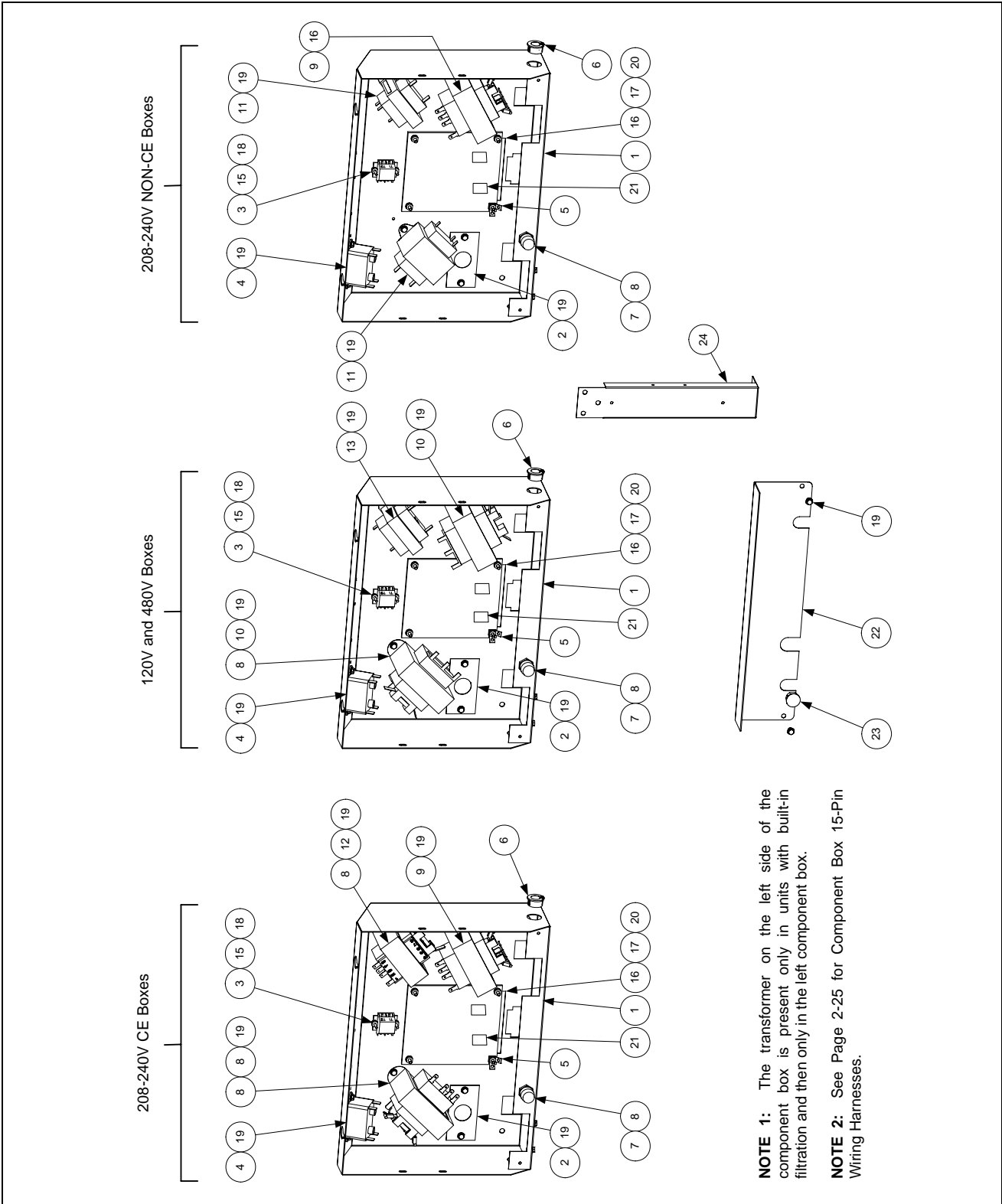

ITEM	STANDARD PART #	EURO-LOOK PART #	COMPONENT
1	106-1531SP		Box Assembly, Component
2	200-3300		Bracket, Component Box Strain Relief
3	806-9495SP		Terminal Block and Wire Assembly
4	807-0012		Relay, 18 Amp 1/3 HP 24V Coil
5	807-0037		Terminal, 1/4-inch Push-on
6	807-0121		Bushing, Heyco Plastic AB-625-500
7	807-1321		Holder, AGC Panel-Mount 1/4-inch Fuse
8	807-1597		Fuse, 3 Amp Slow-Blow
9	807-2180		Transformer, 208-240V 50VA
10	807-2181		Transformer, 100-120V/24V 60VA
11	807-0680		Transformer, 208-240V/24V 20VA
12	807-2191		Transformer, 208-240V/12V 30VA
13	807-0855		Transformer, 100-120V/12V 20VA
14	807-0979		Transformer, 208-240V/12V 43VA
15	826-1366		Nut, 4-40 Keps Hex (Pkg. of 25)
16	809-0250		Nut, 6-32 Keps Hex
17	809-0349		Spacer, 4mm X 6mm Aluminum
18	826-1359		Screw, 4-40 X 3/4-inch Slotted Round Head (Pkg. of 25)
19	809-0359		Screw, #8 X 1/4-inch Hex Washer Head
20			Interface Board
	806-6336SP		Standard (Non-Triac), Full- or Dual-Vat
	806-6347SP		Triac, Full- or Dual-Vat
21	807-3932		Relay, Heat/Latch 12VDC SPDT 12A
22	200-3844		Guard, Finger
23	810-2445		Plug Button
24	200-3243		Brace, Component Box
*	807-3520		Speaker, 4-Watt

\* Not illustrated.

■ Use standard part.

## 2.4.2 Contactor Boxes

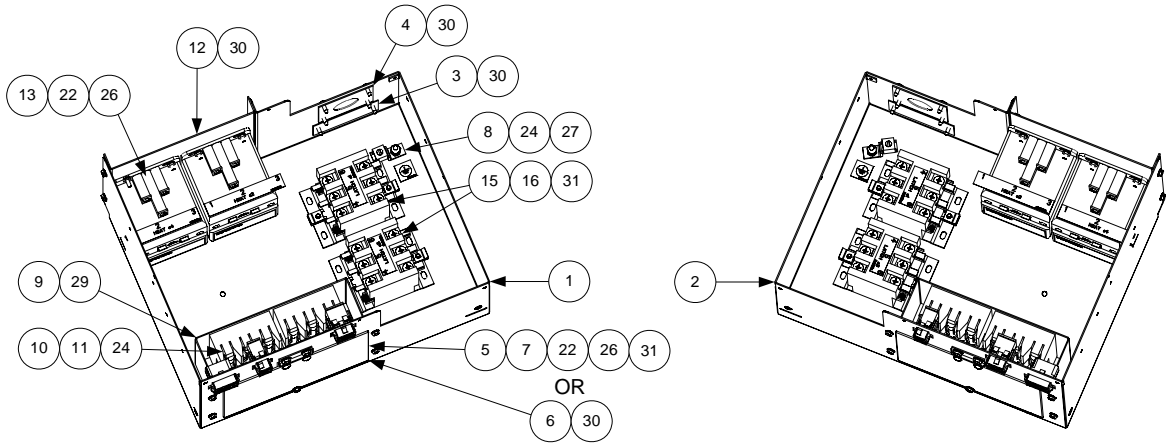

**CONVENTIONAL CONFIGURATION**

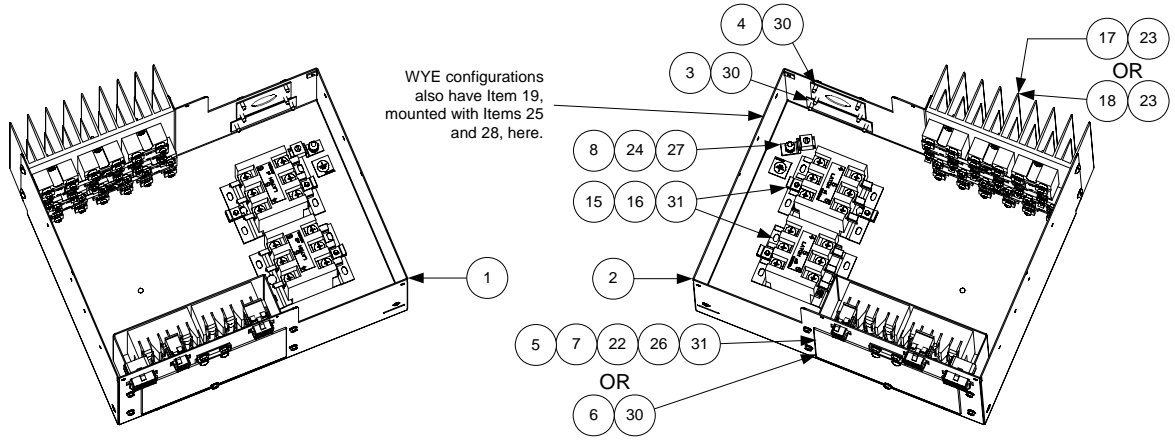

WYE configurations also have Item 19, mounted with Items 25 and 28, here.

**TRIAC CONFIGURATION**

**NOTE:** See Pages 2-21 and 2-22 for Contactor Box Wiring Harnesses

**NOTES:** Left and right contactor box assemblies are mirror images of one another. With the exception of the box itself, all components of a left-hand assembly are the same as those in the corresponding right-hand assembly and vice versa. The configurations illustrated show all possible components, but a particular configuration may not have all the components shown.

ITEM	STANDARD PART #	EURO-LOOK PART #	COMPONENT
1	106-1536SP		Box Assembly, Left Contactor
2	106-1537SP		Box Assembly, Right Contactor
3	200-3111		Cover, Cord Cutout
4	900-2752		Plate, Cordset Adapter
5	200-2334		Door, Contactor Box Hinged
6	200-4712		Door, Contactor Box
7	810-0519		Hinge, Contactor Box Door
8	807-0070		Terminal, Ground Lug
9	200-2336		Bracket, Contactor Box Fuse Block
10	807-0501		Fuse Block, 3-Pole
11	807-2240		Fuse, 60 Amp 300VAC
12	200-2337		Bracket, Mercury Contactor
13	807-1071		Contactor, 24V 30 Amp Mercury
14	807-0884		Contactor, 24V 35-50 Amp Mercury
15	810-1202		Contactor, 24V 40 Amp 3-Pole
16	809-0448		Clip, Tinnerman
17**	806-8674		Heatsink Assembly, DV Solid State Relay (See components below)
18**	806-8673		Heatsink Assembly, FV Solid State Relay (See components below)
19	806-9124		Filter Assembly, Triac ( <i>used in Wye-configured Triac units only</i> )
20	826-1358		Nut, 6-32 Keps Hex (Pkg. of 25)
21	826-1365		Screw, 6-32 X 3/8-inch Slot Head (Pkg. of 25)
22	809-0104		Screw, 8-32 X 1/2-inch Slot Head
23	826-1330		Screw, 10-32 X 3/8-inch Slot Head (Pkg. of 25)
24	809-0123		Screw, #10 X 3/4-inch Slot Head
25	826-1366		Nut, 4-40 Keps Hex (Pkg. of 25)
26	809-0247		Nut, 8-32 Keps Hex
27	826-1376		Nut, 10-32 Keps Hex (Pkg. of 10)
28	826-1359		Screw, 4-40 X 3/4-inch Slot Head (Pkg. of 25)
29	809-0359		Screw, #8 X 1/4-inch Hex Washer Slot Head
30	809-0360		Screw, #8 X 3/8-inch Hex Washer Slot Head
31	826-1374		Screw, #10 X 1/2-inch Hex Head (Pkg. of 25)
*	200-5627		Lid, Left or Right Contactor Box
*			Components of Items 17 and 18
**	807-2751		Relay, Solid State 50 Amp 280V
*	826-1562		Heatsink, Solid State
*	807-0037		Terminal, 1/4-inch Push-on
*	809-0096		Screw, 6-32 X 5/8-inch Slot Head

\* Not illustrated.

■ Use standard part.

\*\* Dual-vat assembly has six relays (826-1562); full-vat assembly has three relays.

## 2.4.3 Heating Element Assemblies and Associated Parts

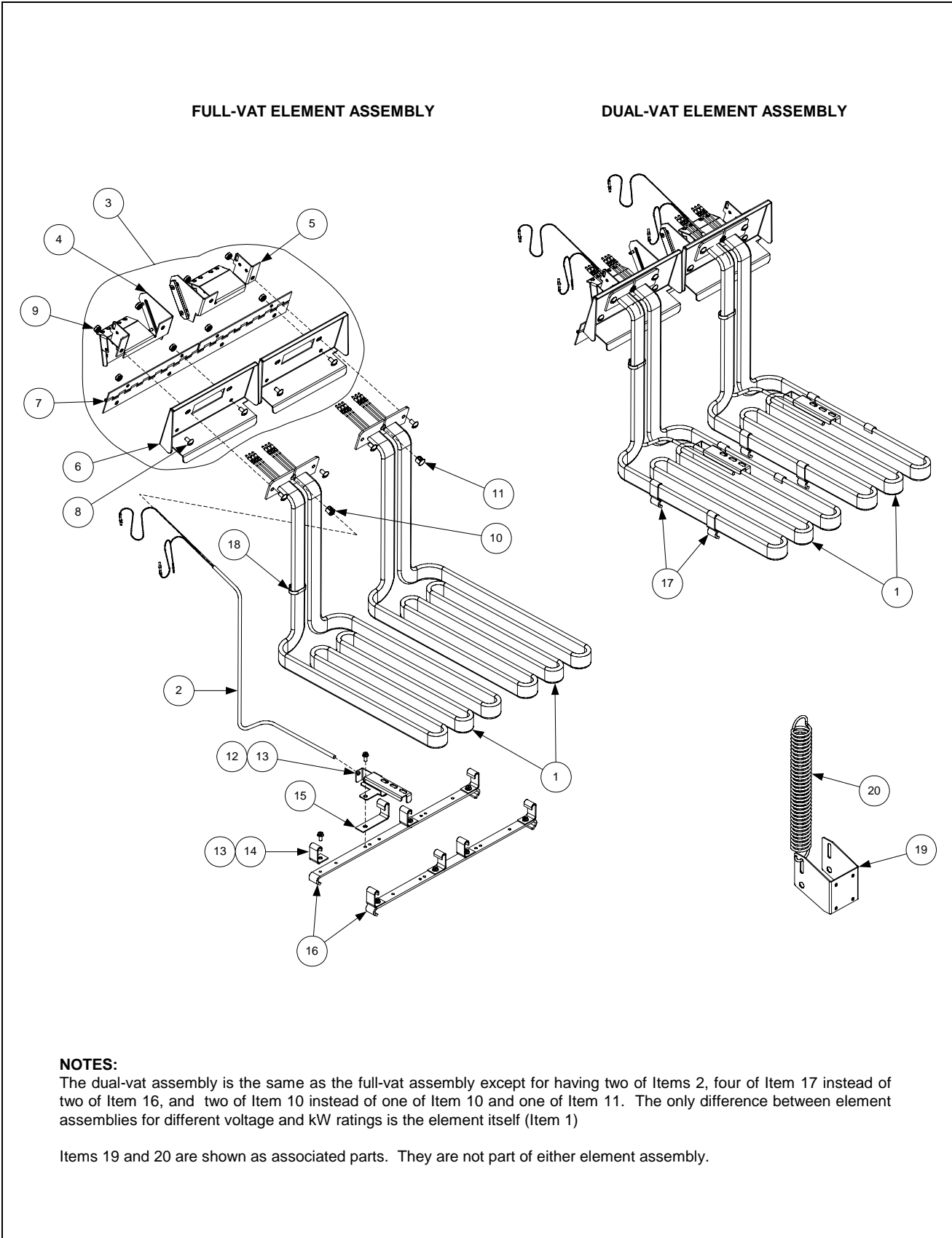

ITEM	STANDARD PART #	EURO-LOOK PART #	COMPONENT
1			Element
	826-2151		200V 7.0 kW
	826-2149		208V 7.0 kW
	826-2155		220V 7.0 kW
	826-2152		230V 7.0 kW
	826-2153		230V/400V 7.0/8.5 kW (used in export 3-phase 4-wire wye units)
	826-2154		240V 7.0 kW
	826-2161		480V 7.0 kW
2	826-1526		Probe, Temperature
3	106-0004SP		Tilt Plate Assembly
4	106-0572SP		Bracket, Left Spring Slot
5	106-0573SP		Bracket, Right Spring Slot
6	910-9641		Tilt Plate
7	810-0035		Hinge
8	826-1330		Screw, 10-32 X 3/8-inch Slotted Truss Head (Pkg. of 25)
9	826-1376		Nut, 10-32 Keps Hex (Pkg. of 10)
10	826-1339		Bushing, .375-inch Split (Pkg. of 10)
11	816-0480		Plug, .375-inch Dome
12	910-5022		Bracket, Temperature Probe
13	809-0518		Screw, 8-32 X 3/8-inch Slotted Hex Head
14	910-2042		Clamp, Element (Short)
15	910-5213		Clamp, Element (Long)
16	910-3681		Support, Full-Vat Element Rear
17	910-5214		Support, Dual-Vat Element Rear
18	809-0567		Tie-Wrap, Metal
19	200-2060		Bracket, Lower Spring Slot
20	810-0297		Spring, Element
*	826-1061		Tilt Switch, Mercury Non-CE (Full-Vat requires one switch and Dual-Vat requires two.)
*	826-2228		Tilt Switch (CE fryers) (Full-Vat requires one switch and Dual-Vat requires two.)

\* Not illustrated.

■ Use standard part.

## 2.4.4 Computers

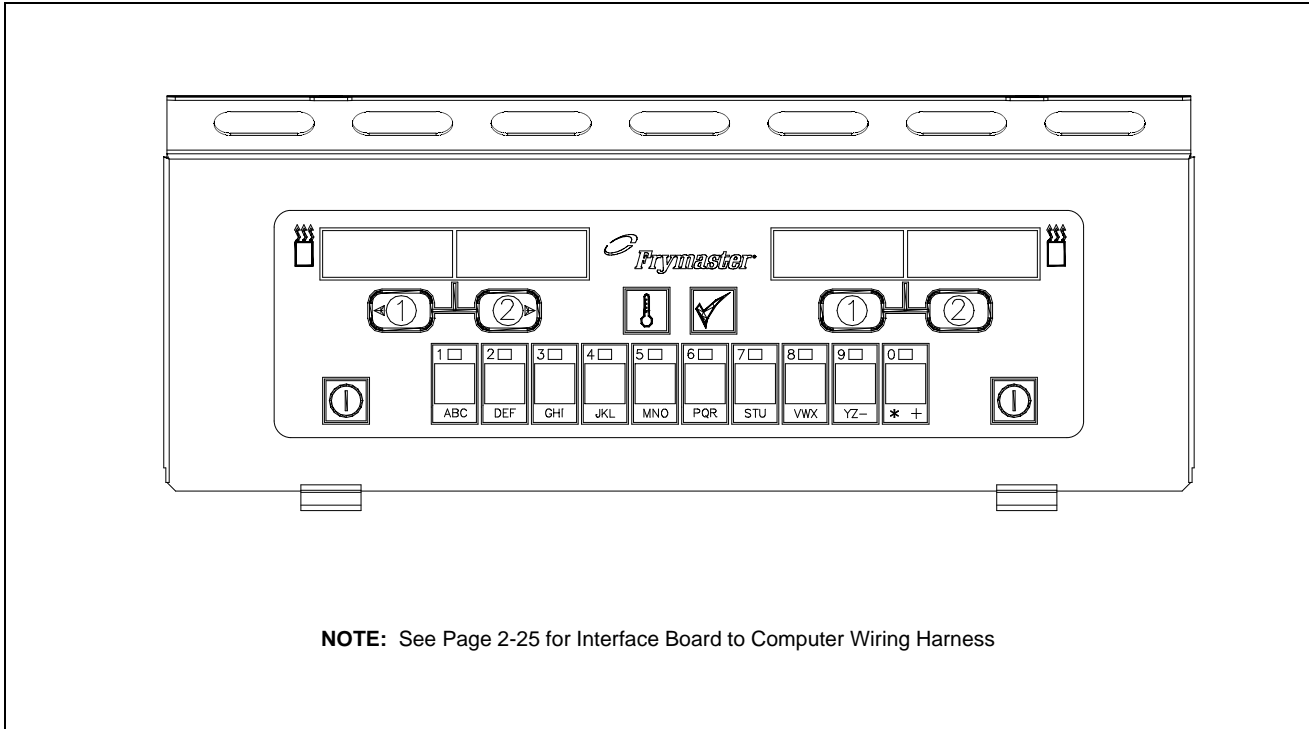

ITEM	STANDARD PART #	COMPONENT
		Replacement Computer (without bezel), Dual- or Full-Vat
	106-0529B	Non-CE
	106-2436B	CE
	823-2986	Replacement Bezel

ITEM	EUROLOOK PART #	COMPONENT
		Replacement Computer (without bezel)
	106-1269	Non-CE
	106-0672	CE
	106-3755	Replacement Frame Assembly



## 2.4.5 Wiring

### 2.4.5.1 Contactor Box Wiring Assemblies – 12-Pin Dual-Vat C-1

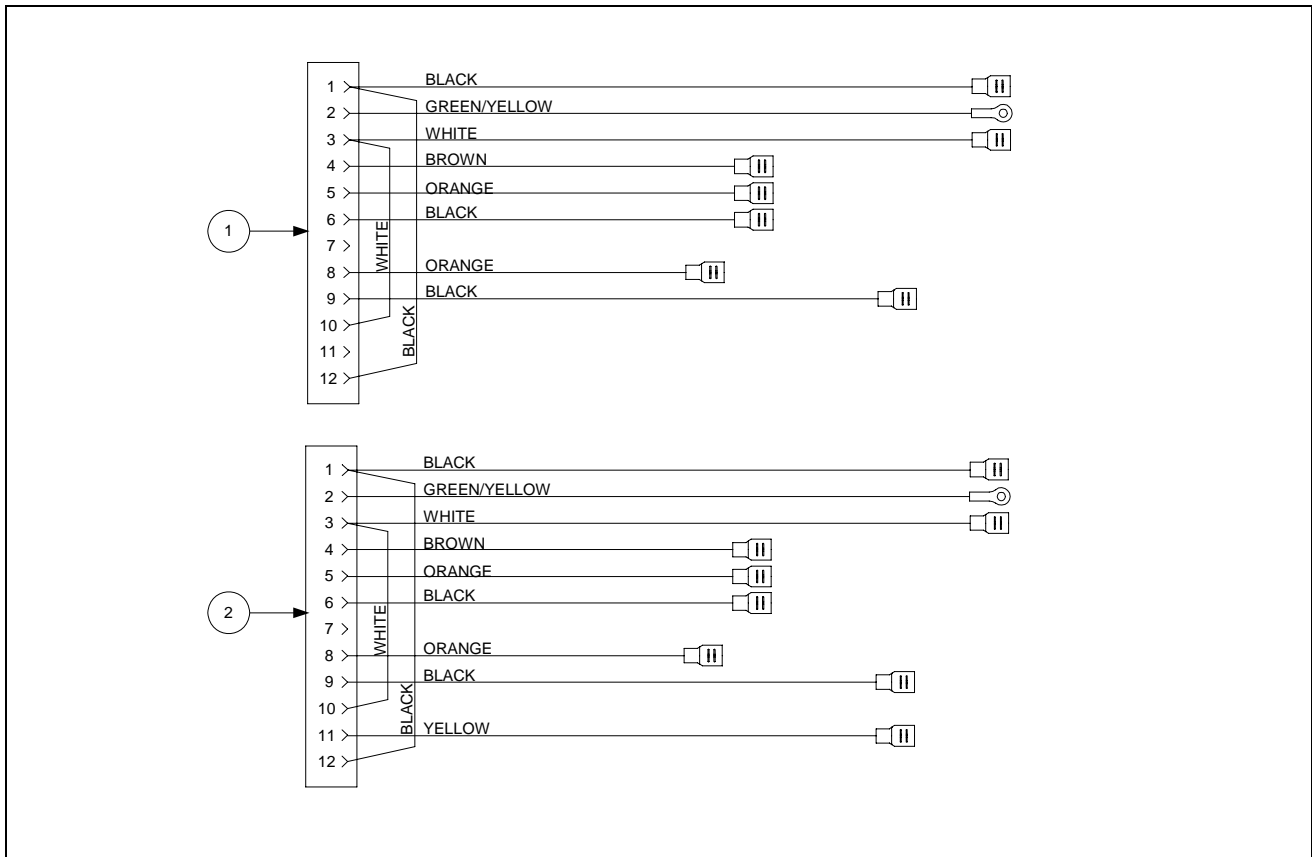

ITEM	STANDARD PART #	EURO-LOOK PART #	COMPONENT
1	106-2428SP		Standard
2	106-2343SP		Triac

■ Use standard part.

### 2.4.5.2 Contactor Box Wiring Assemblies – 12-Pin Full-Vat C-1

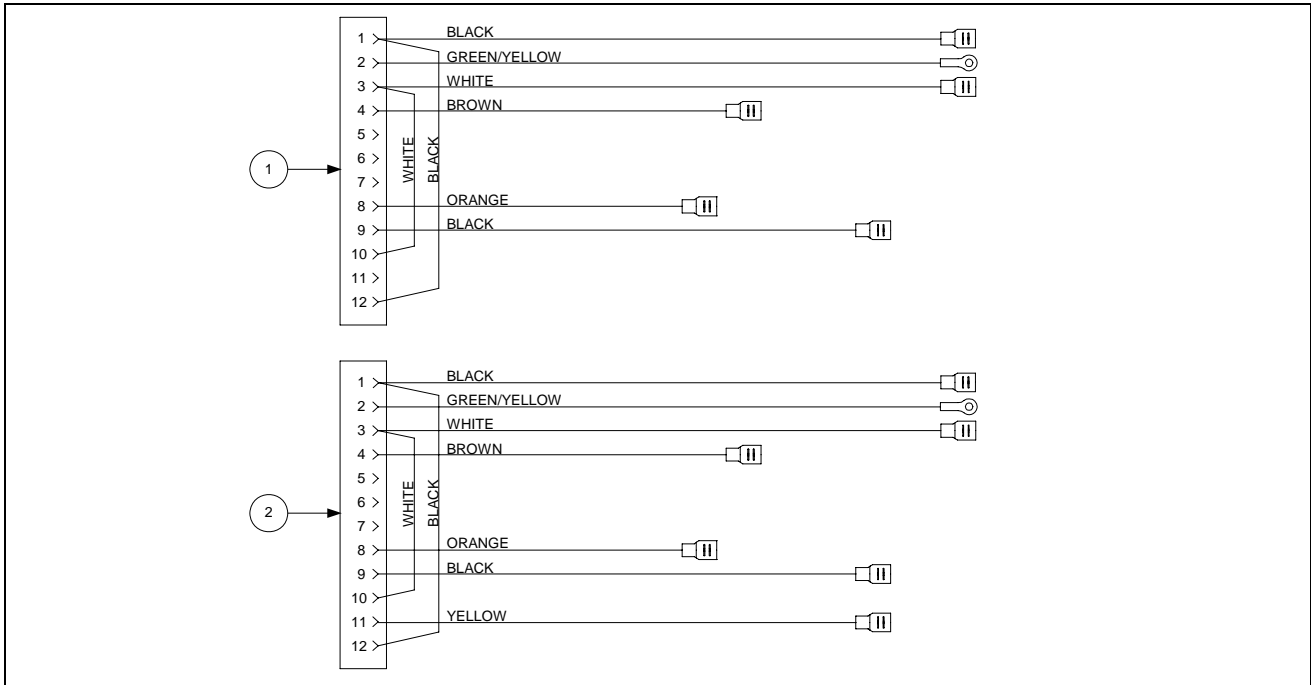

ITEM	STANDARD PART #	EURO-LOOK PART #	COMPONENT
1			Standard
	106-2474SP		Other than 480V
	106-2522SP		480V
2	106-2475SP		Triac

Use standard part.

### 2.4.5.3 Contactor Box Wiring Assembly – 6-Pin (Left Element)

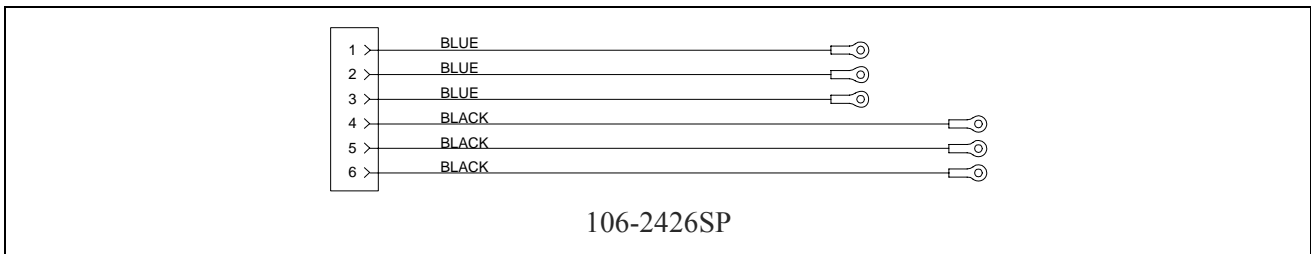

### 2.4.5.4 Contactor Box Wiring Assembly – 9-Pin (Right Element)

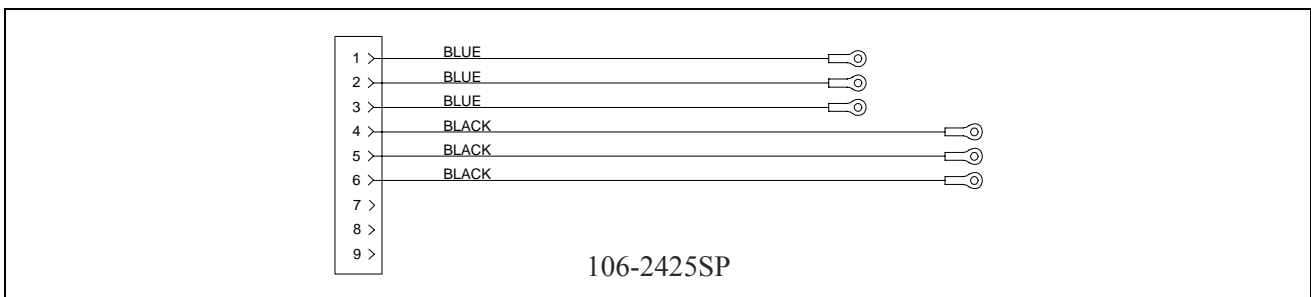

## 2.4.5.5 Main and Multi-Fryer Wiring Harnesses

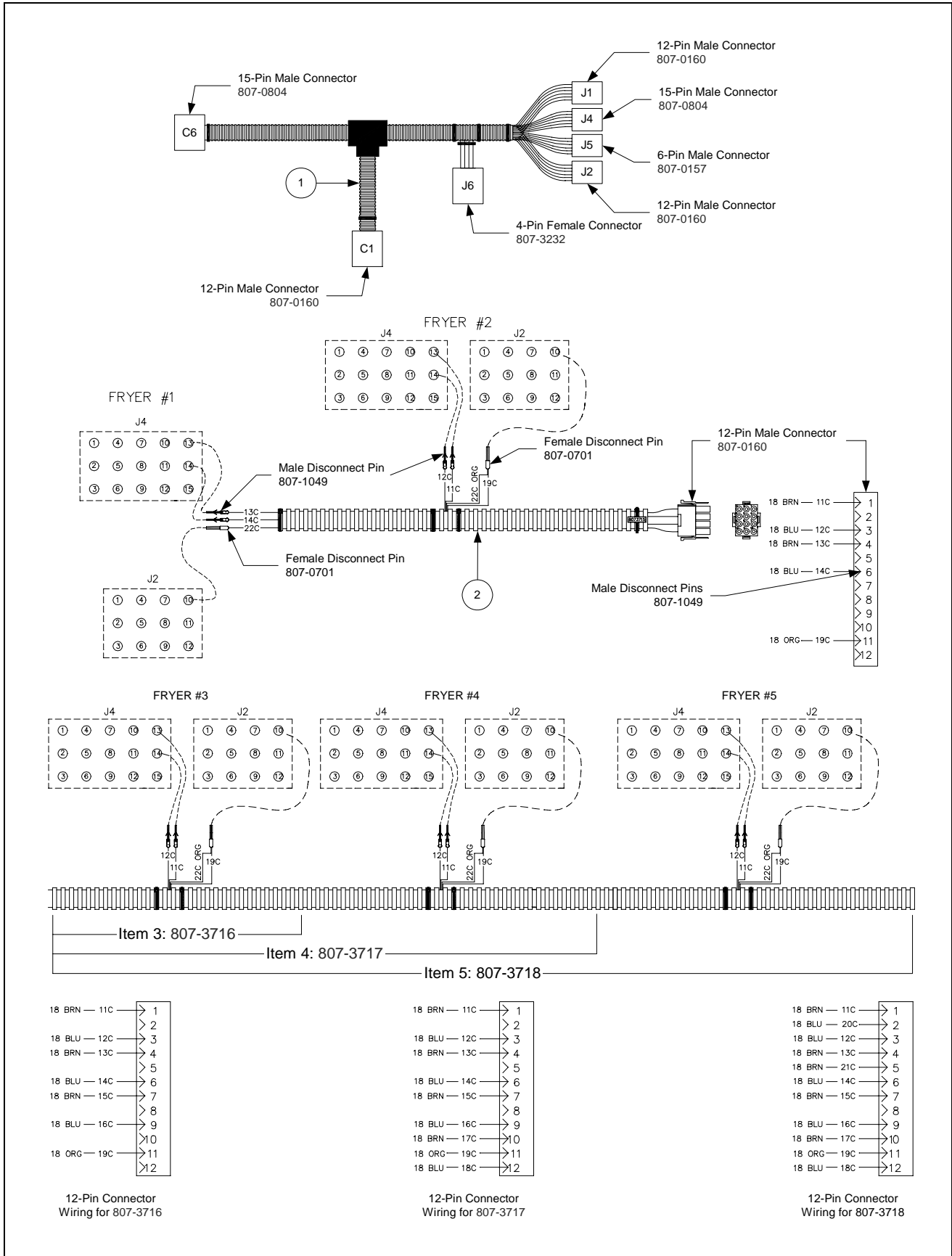

ITEM	STANDARD PART #	EURO-LOOK PART #	COMPONENT
1	807-3769		Main
2	807-3715		Two-Fryer Battery
3	807-3716		Three-Fryer Battery
4	807-3717		Four-Fryer Battery
5	807-3718		Five-Fryer Battery

**NOTE:** Harnesses for 3-, 4-, and 5-Fryer Batteries are similar to 807-3715 but have extra sets of leads as appropriate for the number of fryers in the battery. The connections to Fryer #1 J2 and J4 are the same for all. ■ Use standard part.

### 2.4.5.6 Component Box Wiring Harnesses – 15-Pin

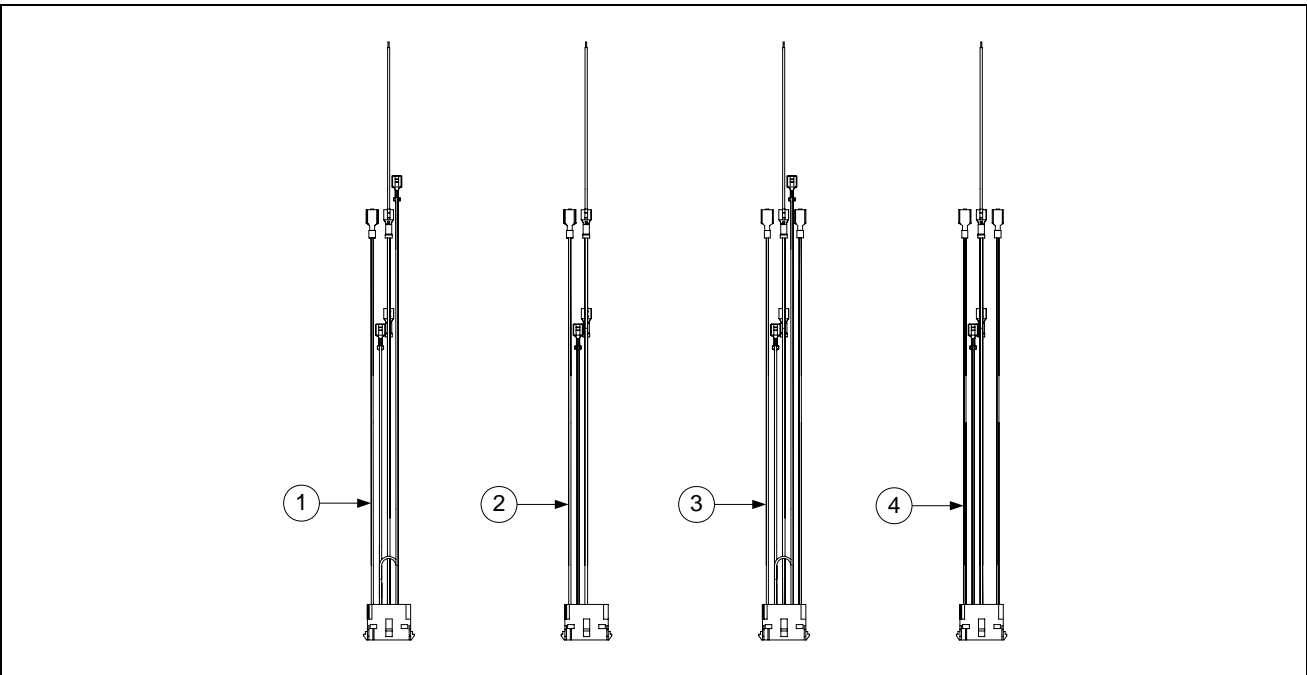

ITEM	STANDARD PART #	EURO-LOOK PART #	COMPONENT
1	106-2506SP		208-480V (With Filter)
2	106-2507SP		208-480V (Without Filter)
3	106-2508SP		120V (With Filter)
4	106-2509SP		120V (Without Filter)

■ Use standard part.

### 2.4.5.7 Interface Board to Controller Wiring Harness – 15-Pin

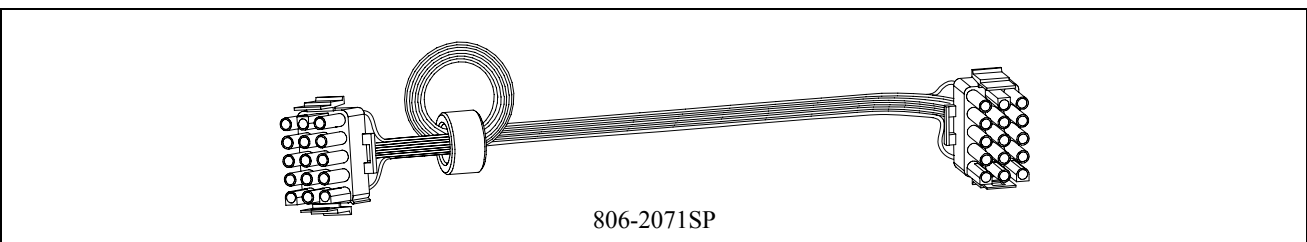

## 2.5 Filtration System Components

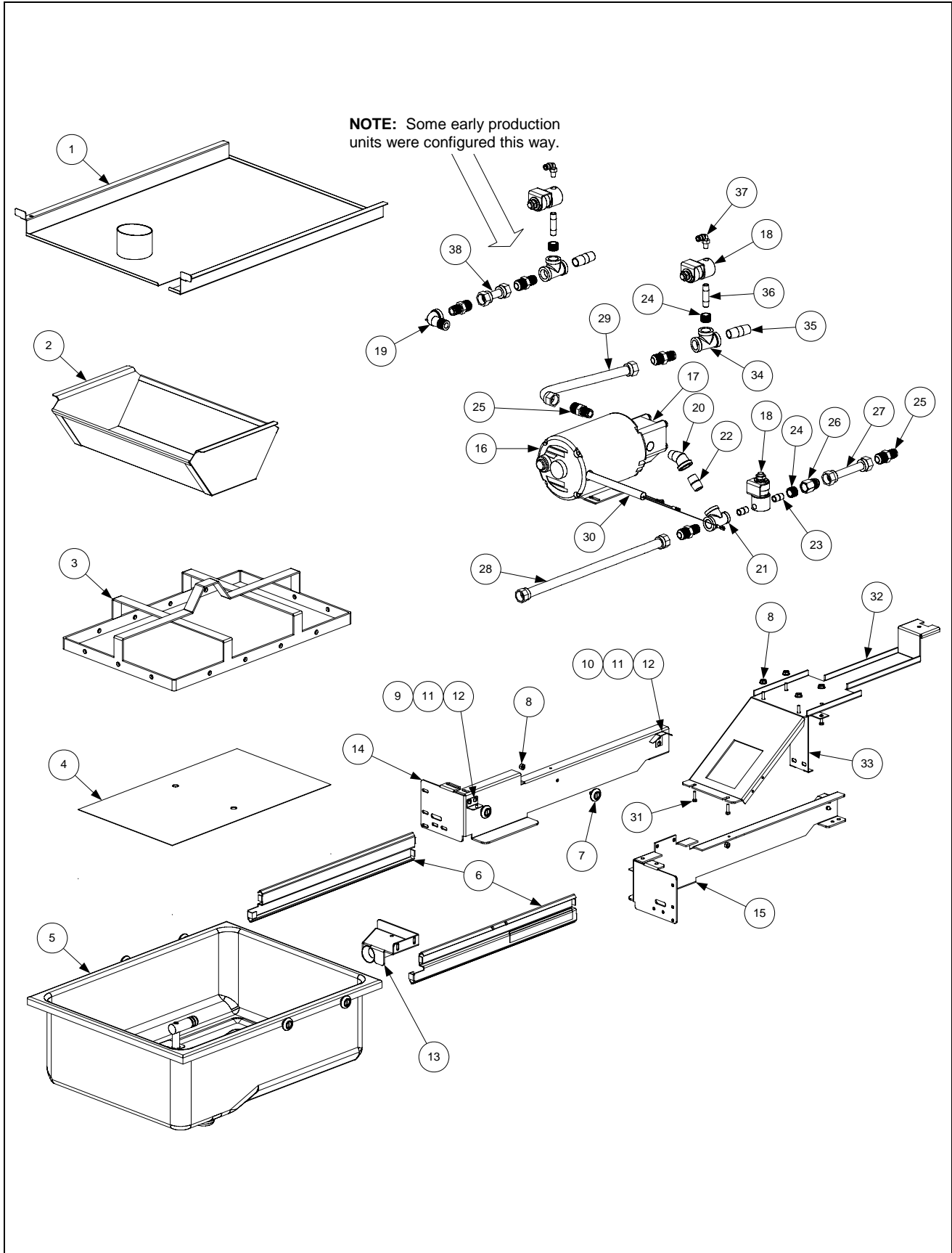

ITEM	STANDARD PART #	EURO-LOOK PART #	COMPONENT
*	826-1979		Filter Pan Roller Kit (four each of Items 7 and 8)
*	826-1980		Service Filter Pan (Item 5, four of Items 7 & 8, two o-rings, two 813-0568)
*	826-1981	826-1981	Service Filter Pan Assembly (Service Filter Pan plus Items 3 and 4)
*	826-1392		O-Ring (Pkg. of 5; used with Item 5)
*	813-0568		Plug, 1/8-inch Socket Head Pipe (used with Item 5; two required)
*	811-1071		Tubing, 1/4-inch OD Teflon Vent (sold by the foot)
*	106-2851SP		Heater Strip Assembly, 100-120V
*	106-2852SP		Heater Strip Assembly, 208-250V
1	823-4637	823-4787	Lid ( <i>for units built before Feb 04, use 823-4391</i> )
2	810-2743		Crumb Tray
3	810-2183		Hold-Down Ring
4	200-2240		SanaGrid Filter Screen
5	106-2617SP		Pan, One-Piece Filter (includes Item 2)
6	810-2012		Rail Set, Filter Pan Roller (includes one left and one right)
7	810-2198		Roller, Filter Pan and Rail
8	826-1368	809-0417	Nut, 1/4-20 Hex Flange (Pkg. of 10)
9	823-4589		Bracket, Lid Support ( <i>for units built before Feb 04, use 823-3875</i> )
10			Guide, Filter Pan Lid
	200-3556		Left
	200-6709		Right
11	809-0104	809-0103	Screw, 8-32 X 1/2-inch Slotted Truss Head
12	809-0247		Nut, 8-32 Hex Keps
13	823-3879		Suction Tube
14	200-4408		Rail, Left Filter
15	200-4409		Rail, Right Filter
16			Motor and Gasket Kit
	826-1785	807-3858	100V 50/60 Hz
	826-1712	807-3859	115V 50/60 Hz
	826-1756	807-3860	208V 50/60 Hz
	826-1757	807-3861	220-240V 50/60 Hz
	826-1755	807-3862	250V 50/60 Hz
17	826-1264		Pump and Gasket Kit
	810-2716		Pump, Viking 4GPM 2-piece
	816-0093		Gasket, Pump/Motor
18	807-2484		Valve, 1/4-inch Solenoid
19	813-0165		Elbow, 1/2-inch 90° Street
20	813-0342		Elbow, 1/2-inch 45° Street
21	813-0530		Tee, 1/2-inch X 1/4-inch X 1/2-inch Reducing
22	813-0022		Nipple, 1/2-inch Close
23	813-0838		Nipple, 1/4-inch Close
24	813-0304		Bushing, 1/2-inch to 1/4-inch Flush
25	810-1668		Adapter, 5/8-inch to 1/2-inch NPT Male
26	810-1669		Adapter, 5/8-inch to 1/2-inch NPT Female
27	810-1680		Flexline, 6.5-inch Oil Return
28	810-1369		Flexline, 17.5-inch Oil Return

Use standard part.

Continued on next page...

29	810-1055		Flexline, 11.5-inch Oil Return
30	807-3828		Cable, FootPrint Pro Pump Motor
31	826-1375	809-0401	Screw, 10-32 X 3/4-inch Hex Trim Head (Pkg. of 5)
32	200-5950	200-8467	Bridge, Filter Motor
33	210-3149		Support, Contactor Box
34	813-0003	813-0003	Tee, 1/2-Inch
35	813-0298	813-0298	Nipple, 1/2-inch 2.0-inch
36	813-0537	813-0537	Nipple, 1/4-inch 2.0-inch
37	810-2493	810-2493	Fitting, 1/4-inch X 90° Quick-Connect
38	810-1160		Flexline, 3.0-inch Oil Return
*		810-1043	Flexline, 0.5-inch Oil Return
*		810-1057	Flexline, 13.0-inch Oil Return

\* Not illustrated.

■ Use standard part.

## 2.6 Frypot Assemblies and Associated Parts

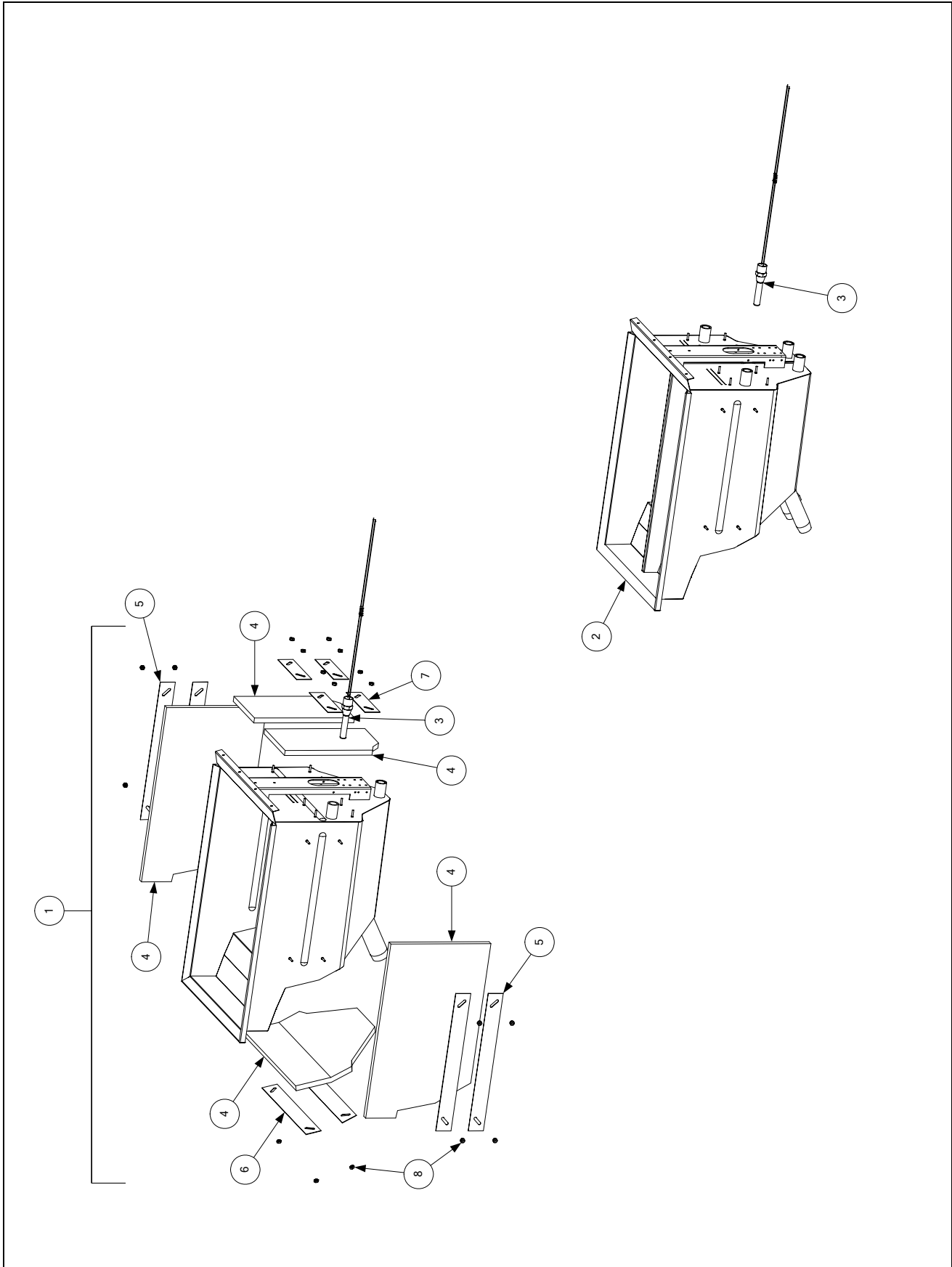



ITEM	STANDARD PART #	COMPONENT
1	823-4775	Frypot, McDonald's, Full-vat
2	823-4778SP	Frypot, McDonald's, Dual-vat
3		Thermostat Assembly, High-Limit
	806-7543	Non-CE Full Vat 425°F (218°C) (Color Coded Black)
	806-8035	Non-CE Dual Vat 435°F (224°C) (Color Coded Red)
	806-8132	CE Full and Dual Vat 415°F (213°C) (Color-Coded Yellow)
4	812-0211	Insulation, Kaowool 17-inch X 10-inch X ½-inch (4 required per pot)
5	900-4100	Retainer, Side Insulation
6	900-4101	Retainer, Front Insulation
7	900-1345	Retainer, Rear Insulation
8	826-1376	Nut, 10-32 Keps Hex (Pkg. of 10)

## 2.7 Oil Return System Components

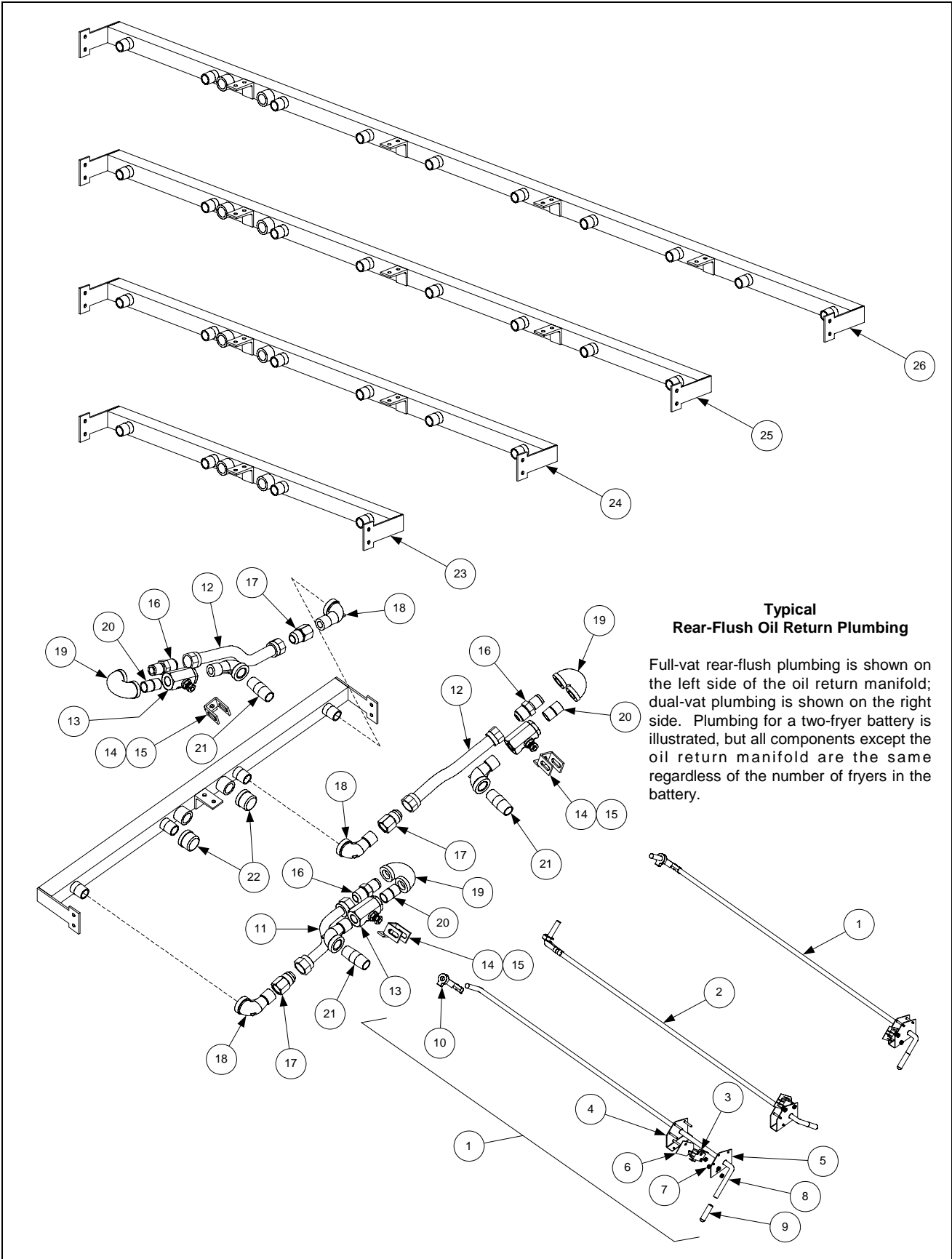

ITEM	STANDARD PART #	EURO-LOOK PART #	COMPONENT
1	106-2465SP		Handle Assembly, Full-Vat and Right Dual-Vat Rear Flush Complete
2	106-2687SP		Handle Assembly, Left Dual-Vat Rear Flush Complete
3	807-2103		Microswitch, Straight Lever
4	106-3349		Bracket Assembly, Microswitch
5	200-5401		Bracket, Handle Retainer
6	816-0220		Insulation, Oil Return Microswitch
7	826-1366		Nut, 4-40 Keps Hex (Pkg. of 25)
8	810-2534		Rod, Full-Vat and Right Dual Vat Rear Flush ( <i>use 810-2533 for Left DV</i> )
9	810-0677		Grip, Oil Return Valve Handle
10	809-0601		Clip, Clevis
11	810-2532		Flexline, 7.0-inch
12	810-1067		Flexline, 8.5-inch
13	810-0278		Valve, ½-inch Ball
14	200-5438		Handle, Rear Flush Valve
15	900-2935		Retainer, Oil Return Valve Nut
16	810-1668		Adapter, ⅝-inch to ½-inch NPT Male
17	810-1669		Adapter, ⅝-inch to ½-inch NPT Female
18	813-0165		Elbow, ½-inch X 90° Street
19	813-0570		Elbow, 180° ½-inch NPT
20	813-0022		Nipple, ½-inch X Close NPT
21	813-0298		Nipple, ½-inch X 2.0-inch NPT
22	813-0469		Cap, ½-inch NPT Pipe
23	810-2255		Manifold, Two-Station Fryer ( <i>use 810-2543 for non-filter units</i> )
24	810-2256		Manifold, Three-Station Fryer ( <i>use 810-2544 for non-filter units</i> )
25	810-2257		Manifold, Four-Station Fryer ( <i>use 810-2545 for non-filter units</i> )
26	810-2312		Manifold, Five-Station Fryer ( <i>use 810-2546 for non-filter units</i> )

■ Use standard part.

## 2.8 Wiring Connectors, Pin Terminals, and Power Cords

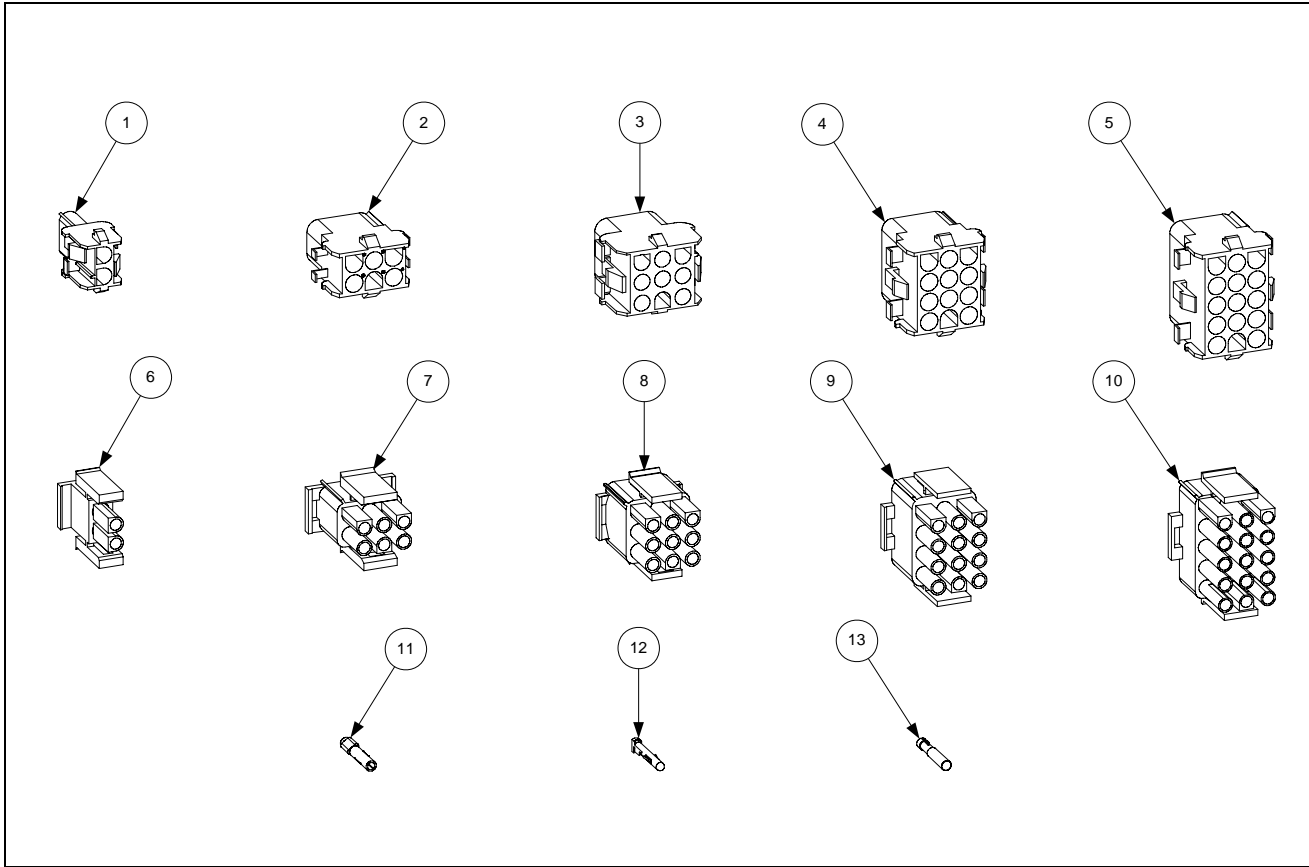

ITEM	STANDARD PART #	EUROLOOK PART #	COMPONENT
			<b>Power Cords</b>
*	807-0154		100/120V–15A 3-wire, w/grounded plug
*	807-1685		100/208/240V–18A 3-wire, w/o plug
*	806-6083		120V 5-wire, w/grounded plug
*	807-3817		208/240V 3-Phase 4-wire w/grounded plug
			<b>Connectors</b>
1	807-1068		2-Pin Female
2	807-0158		6-Pin Female
3	807-0156		9-Pin Female
5	807-0159		12-Pin Female
5	807-0875		15-Pin Female
6	807-1067		2-Pin Male
7	807-0157		6-Pin Male
8	807-0155		9-Pin Male
9	807-0160		12-Pin Male
10	807-0804		15-Pin Male
11	826-1341		Terminal, Female Split Pin (Pkg of 25)
12	826-1342		Terminal, Male Split Pin (Pkg of 25)
13	807-2518		Plug, Mate-N-Lock (Dummy Pin)

\* Not illustrated.

Use standard part.

## 2.9 Control Cord Box

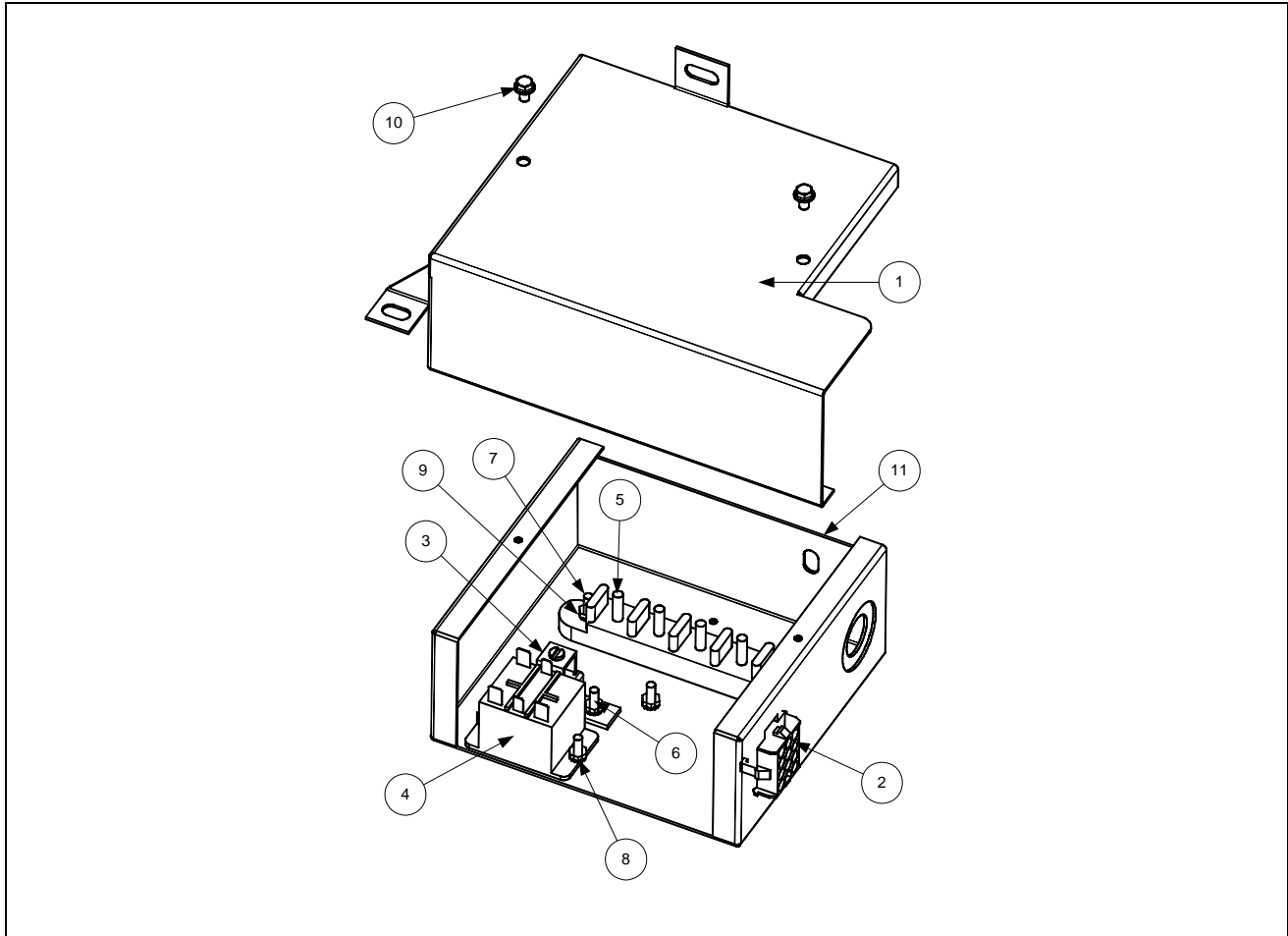

ITEM	STANDARD PART #	EURO-LOOK PART #	COMPONENT
	806-9794		<b>Control Cord Box</b>
1	200-3379		Cover, MAC Control Cord Box
2	806-9795		Harness Assembly, MAC
3	807-0070		Terminal, Ground Lug
4	807-1683		Relay, 12 VDC Hood
5	807-1973		Terminal, Post
6	809-0104		Screw, 8-32 x 1/2" Truss Slotted Head
7	809-0123		Screw, #10 x 3/4" Truss Slotted Head
8	809-0247		Nut, 8-32 Hex Keys
9	809-0256		Nut, 10-32 Hex Keys
10	809-0359		Screw, #8 x 1/4" Washer Slotted Hex Head
11	900-8024		Box, MAC Control Cord
*	WIR0324		Wiring Assembly

\* Not illustrated.

Use standard part.



**Enodis**<sup>®</sup>  
One Company, Countless Solutions

Frymaster, L.L.C., 8700 Line Avenue, PO Box 51000, Shreveport, Louisiana 71135-1000  
Shipping Address: 8700 Line Avenue, Shreveport, Louisiana 71106

TEL 1-318-865-1711

FAX (Parts) 1-318-219-7140

(Tech Support) 1-318-219-7135

PRINTED IN THE UNITED STATES

SERVICE HOTLINE  
1-800-551-8633

819-6011  
MAY 2006