

FPD65 Series with Built-In Filtration



**Frymaster FPD65 Series
Gas Fryers
Installation & Operation Manual**

**PARTS LIST
INCLUDED**



Frymaster, a member of the Commercial Food Equipment Service Association, recommends using CFESA Certified Technicians.

24-Hour Service Hotline 1-800-551-8633

SEPT 2008

*** 8196039 ***

Please read all sections of this manual and retain for future reference.

NOTICE

This appliance is intended for professional use only and is to be operated by qualified personnel only. A Frymaster/Dean Factory Authorized Service Center (FASC) or other qualified professional should perform installation, maintenance, and repairs. Installation, maintenance, or repairs by unqualified personnel may void the manufacturer's warranty. See Chapter 1 of this manual for definitions of qualified personnel.

NOTICE

This equipment must be installed in accordance with the appropriate national and local codes of the country and/or region in which the appliance is installed. See NATIONAL CODE REQUIREMENTS in Chapter 3 of this manual for specifics.

NOTICE

Drawings and photos used in this manual are intended to illustrate operational, cleaning and technical procedures and may not conform to onsite management operational procedures.

NOTICE TO OWNERS OF UNITS EQUIPPED WITH COMPUTERS

U.S.

This device complies with Part 15 of the FCC rules. Operation is subject to the following two conditions: 1) This device may not cause harmful interference, and 2) This device must accept any interference received, including interference that may cause undesired operation. While this device is a verified Class A device, it has been shown to meet Class B limits.

CANADA

This digital apparatus does not exceed the Class A or B limits for radio noise emissions as set out by the ICES-003 standard of the Canadian Department of Communications.

Cet appareil numérique n'émet pas de bruits radioélectriques dépassant les limites de classe A et B prescrites dans la norme NMB-003 édictée par le Ministre des Communications du Canada.

NOTICE

IF, DURING THE WARRANTY PERIOD, THE CUSTOMER USES A PART FOR THIS ENODIS EQUIPMENT OTHER THAN AN UNMODIFIED NEW OR RECYCLED PART PURCHASED DIRECTLY FROM FRYMASTER/DEAN, OR ANY OF ITS AUTHORIZED SERVICE CENTERS, AND/OR THE PART BEING USED IS MODIFIED FROM ITS ORIGINAL CONFIGURATION, THIS WARRANTY WILL BE VOID. FURTHER, FRYMASTER/DEAN AND ITS AFFILIATES WILL NOT BE LIABLE FOR ANY CLAIMS, DAMAGES OR EXPENSES INCURRED BY THE CUSTOMER WHICH ARISE DIRECTLY OR INDIRECTLY, IN WHOLE OR IN PART, DUE TO THE INSTALLATION OF ANY MODIFIED PART AND/OR PART RECEIVED FROM AN UNAUTHORIZED SERVICE CENTER.

NOTICE

The Commonwealth of Massachusetts requires any and all gas products to be installed by a licensed plumber or pipe fitter.

⚠ DANGER

Improper installation, adjustment, maintenance or service, and unauthorized alterations or modifications can cause property damage, injury, or death. Read the installation, operating and service instructions thoroughly before installing or servicing this equipment. Only qualified service personnel may convert this appliance to use a gas other than that for which it was originally configured. See Chapter 1 of this manual for definition of qualified service personnel.

⚠ DANGER

Adequate means must be provided to limit the movement of this appliance without depending upon the gas line connection. Single fryers equipped with legs must be stabilized by installing anchor straps. All fryers equipped with casters must be stabilized by installing restraining chains. If a flexible gas line is used, an additional restraining cable must be connected at all times when the fryer is in use.

⚠ DANGER

The front ledge of the fryer is not a step. Do not stand on the fryer. Serious injury can result from slips or contact with the hot oil.

⚠ DANGER

Do not store or use gasoline or other flammable vapors and liquids in the vicinity of this or any other appliance.

⚠ DANGER

Instructions to be followed in the event the operator smells gas or otherwise detects a gas leak must be posted in a prominent location. This information can be obtained from the local gas company or gas supplier.

⚠ DANGER

The crumb tray in fryers equipped with a filter system must be emptied into a fireproof container at the end of frying operations each day. Some food particles can spontaneously combust if left soaking in certain shortening material. Additional information can be obtained in the filtration manual included with the system.

⚠ WARNING

No structural material on the fryer should be altered or removed to accommodate placement of the fryer under a hood. Questions? Call the Frymaster/Dean Service Hotline at 1-800-551-8633.

⚠ WARNING

Do not bang fry baskets or other utensils on the fryer's joiner strip. The strip is present to seal the joint between the frypot. Banging fry baskets on the strip to dislodge shortening will distort the strip, adversely affecting its fit. It is designed for a tight fit and should only be removed for cleaning.



**FPD65 Series Gas Fryers
Installation & Operation Manual**

TABLE OF CONTENTS

	Page #
1. INTRODUCTION.....	1-1
1.1 After Purchase.....	1-1
1.2 Ordering Parts.....	1-1
1.3 Service Information.....	1-1
1.4 Computer Information.....	1-1
1.5 Safety Information.....	1-2
1.6 Service Personnel.....	1-3
2. IMPORTANT INFORMATION.....	2-1
2.1 Receiving and Unpacking Equipment.....	2-1
2.2 General.....	2-2
2.3 Principles of Operation.....	2-3
2.4 Rating Plate.....	2-3
2.5 Pre-Installation.....	2-3
2.6 Air Supply and Ventilation.....	2-5
2.7 Equipment Installed at High Altitudes.....	2-5
3. INSTALLATION.....	3-1
3.1 Installing the Fryer.....	3-1
3.2 Gas Connections.....	3-4
3.3 Adjustments/Adaptation to Different Gases.....	3-7
3.4 Electrical Connections.....	3-9
4. FRYER OPERATIONS.....	4-1
4.1 Initial Start-up.....	4-1
4.2 Boil-Out Procedure.....	4-3
4.3 Final Preparation.....	4-5



**FPD65 Series Gas Fryers
Installation & Operation Manual**

TABLE OF CONTENTS (CONT.)

	Page #
5. FILTRATION OPERATION	5-1
5.1 General.....	5-1
5.2 Filtration Preparation.....	5-1
5.3 Daily Filtration Operation.....	5-4
5.4 Operating the Filter.....	5-6
6. PREVENTATIVE MAINTENANCE	6-1
6.1 General.....	6-1
7. TROUBLESHOOTING	7-1
7.1 General.....	7-1
7.2 Pilot Burner Malfunction.....	7-2
7.3 Main Burner Malfunctions.....	7-2
7.4 Wiring Diagram, Main.....	7-4
7.5 Wiring Diagram, Filter.....	7-5
8. PARTS LIST	8-1
8.1 Cabinetry and Related Components.....	8-1
8.2 Doors, Topcaps and Related Components.....	8-3
8.3 Frypots, Burners and Related Components.....	8-4
8.4 Component Box Components.....	8-6
8.5 Filter Pan and Related Components.....	8-7
8.6 Oil-Drain Components.....	8-8
8.7 Oil-Return Components.....	8-10
8.8 Suction Tube, Oil-Return Components.....	8-11

FRYMASTER FPD65 SERIES GAS FRYERS

CHAPTER 1: INTRODUCTION

1.1 After Purchase

In order to improve service, have the following chart filled in by the Frymaster/Dean Authorized Service Technician who installed this equipment.

Authorized Service
Technician/FASC
Address

Telephone/Fax
Model Number
Serial Number
Gas Type

1.2 Ordering Parts

Customers may order parts directly from their local factory authorized service center. For this address and phone number, contact your factory authorized service center or call the Frymaster/Dean Service Hotline phone number, 1-800-551-8633.

To speed up your order, provide the model number, serial number, gas type, part needed, item part number (if known), and quantity needed.

1.3 Service Information

Call the Frymaster/Dean Service Hotline, 1-800-551-8633, for the location of your nearest factory authorized service center. To assist you more efficiently, always provide the service technician with the model number, gas type, serial number, and the nature of the problem.

1.4 Computer Information

This equipment has been tested and found to comply with the limits for a Class A digital device, pursuant to Part 15 of the FCC rules. While this device is a verified Class A device, it has been shown to meet the Class B limits. These limits are designed to provide reasonable protection against harmful interference when the equipment is operated in a commercial environment. This equipment generates, uses and can radiate radio frequency energy and, if not installed and used in accordance with the instruction manual, may cause harmful interference to radio communications. Operation of the equipment in a residential area is likely to cause harmful interference in which case the user will be required to correct the interference at his/her own expense.

FRYMASTER FPD65 SERIES GAS FRYERS

CHAPTER 1: INTRODUCTION

1.4 Computer Information (cont.)

The user is cautioned that any changes or modifications not expressly approved by the party responsible for compliance could void the user's authority to operate the equipment.

If necessary, the user should consult the dealer or an experienced radio and television technician for additional suggestions.

The user may find the following booklet prepared by the Federal Communications Commission helpful: "How to Identify and Resolve Radio-TV Interference Problems". This booklet is available from the U.S. Government Printing Office, Washington, DC 20402, Stock No. 004-000-00345-4.

1.5 Safety Information

Before attempting to operate your unit, read the instructions in this manual thoroughly.

Throughout this manual, you will find notations enclosed in double-bordered boxes similar to the ones below.

CAUTION

CAUTION boxes contain information about actions or conditions that *may cause or result in a malfunction of your system.*

WARNING

WARNING boxes contain information about actions or conditions that *may cause or result in damage to your system,* and which may cause your system to malfunction.

DANGER

DANGER boxes contain information about actions or conditions that *may cause or result in injury to personnel,* and which may cause damage to your system and/or cause your system to malfunction.

FRYMASTER FPD65 SERIES GAS FRYERS
CHAPTER 1: INTRODUCTION

1.6 Service Personnel

1.6.1 Definitions

A. Qualified and/or Authorized Operating Personnel

1. Qualified/authorized operating personnel are those who have carefully read the information in this manual and have familiarized themselves with the equipment functions, or have had previous experience with the operation of equipment covered in this manual.

B. Qualified Installation Personnel

1. Qualified installation personnel are individuals, or firms, corporations, or companies, which, either in person or through a representative are engaged in and are responsible for the installation of gas-fired appliances. Qualified personnel must be experienced in such work, be familiar with all gas precautions involved, and have complied with all requirements of applicable national and local codes.

C. Qualified Service Personnel

1. Qualified service personnel are those who are familiar with Frymaster/Dean equipment and have been authorized by Frymaster/Dean to perform service on Frymaster/Dean equipment. All authorized service personnel are required to be equipped with a complete set of service parts manuals and stock a minimum amount of parts for Frymaster/Dean equipment. A list of Frymaster/Dean Factory Authorized Service Centers (FASCs) was included with the fryer when shipped from the factory. *Failure to use qualified service personnel will void the Frymaster/Dean warranty on your equipment.*

FRYMASTER FPD65 SERIES GAS FRYERS

CHAPTER 2: IMPORTANT INFORMATION

2.1 Receiving and Unpacking Equipment

- A. Check that the containers are upright. Use an outward prying motion - *no hammering* - to remove the cartons. Unpack fryers carefully and remove all accessories from the carton and/or frypots. Do not discard or misplace accessories, as they will be needed during final assembly and fryer operation.
- B. After unpacking, immediately check the equipment for visible signs of shipping damage. If damage has occurred, contact the carrier and file the appropriate freight claims. Do not contact the factory. Shipping damage responsibility is between the carrier and the dealer.

If your equipment arrives damaged:

1. File claim for damages immediately, regardless of extent of damage.
2. Visible loss or damage: Be sure this is noted on the freight bill or express receipt and is signed by the person making the delivery.
3. Concealed loss or damage: If damage is unnoticed until equipment is unpacked, notify freight company or carrier immediately, and file a concealed damage claim. This should be done within 15 days of date of delivery. Be sure to retain container and all packing materials for inspection.

NOTE: Frymaster/Dean Does Not Assume Responsibility for Damage or Loss Incurred in Transit.

- C. **Built-in filtration cabinet:** Remove the filter pan from the cabinet before removing system from pallet.
- D. **Five- and Six-battery Frying Systems:** Units are shipped on two pallets. Casters are pre-installed on the frying system and unloading ramps are furnished to facilitate removal of the units off the pallets. Remove pallet supports from underneath fryer and carefully roll the unit down the ramps from the front (cooking side). **See assembly instructions shipped with unit for system assembly.**
- E. Remove all plastic skin from sides, front, and doors of the fryers. Units are shipped with plastic skin to protect the stainless components from surface damage during shipping. Failure to remove the plastic prior to initial fryer operation will make it very difficult to remove later.

FRYMASTER FPD65 SERIES GAS FRYERS

CHAPTER 2: IMPORTANT INFORMATION

2.2 General

Qualified, licensed, and/or authorized installation or service personnel only (as defined in Section 1.6) should perform the following:

- Installation and service on Frymaster/Dean equipment.
- Conversion of this appliance from one gas type to another.

Failure to use qualified, licensed, and/or authorized installation or service personnel to install, convert to another gas type or otherwise service this equipment will void the Frymaster/Dean warranty and may result in damage to the equipment or injury to personnel.

Where conflicts exist between instructions and information in this manual and local code or national codes, or regulations, installation and operation shall comply with the codes or regulations in force in the country in which the equipment is installed.

DANGER

Building codes prohibit a fryer with its open tank of hot oil/shortening from being installed beside an open flame of any type, including those of broilers and ranges.

Upon arrival, inspect the fryer carefully for visible or concealed damage. (See Receiving and Unpacking Equipment in Section 2.1.)

2.2.1 Product Description

Frymaster FPD65 Series gas fryers are energy efficient, tube-style, gas-fired units. All units are shipped completely assembled with accessories packed inside the frypot. Frymaster FPD65 Series gas fryers are adjusted, tested and inspected at the factory before shipment. The input rates of this model are listed in this manual.

WARNING

The on-site supervisor is responsible for ensuring that operators are made aware of the inherent hazards of operating a hot oil frying system, particularly the aspects of system operation, oil filtration, draining and cleaning procedures.

FRYMASTER FPD65 SERIES GAS FRYERS

CHAPTER 2: IMPORTANT INFORMATION

2.3 Principles of Operation

The incoming gas flows through orifices and is mixed with air in the burners to create the correct ratio for proper combustion. The mixture is ignited at the front end of each heat tube by the pilot light. Internal diffusers slow the flame as it goes through the burner tube. This slower and more turbulent flame gives much better heat transfer to the walls of the tubes, thereby heating the oil better.

2.4 Rating Plate

This is attached to the inside front door panel. Information provided includes the model and serial number of the fryer, BTU/hr input of the burners, outlet gas pressure in inches W.C. and whether the unit has natural or propane gas orifices.

 **DANGER**

Fryers MUST be connected ONLY to the gas type identified on the attached rating plate.

2.5 Pre-Installation

 **DANGER**

No structural material on the fryer should be altered or removed to accommodate placement of the fryer under a hood. Questions? Call the Frymaster/Dean Service Hotline at 1-800-551-8633.

 **DANGER**

Do not connect this appliance to the gas supply before reviewing all information in this chapter.

- A. **General:** Only licensed personnel should install any gas-fired equipment.
1. A manual gas shut-off valve must be installed in the gas supply line ahead of the fryers for safety and ease of future service.
 2. Frymaster FPD65 Series gas fryers require 120VAC 60 cycle or 230VAC single-phase 50-hertz (International/CE) electrical service and are equipped with a 16-3 SJT grounded flexible power cord for a direct connection to the power supply. Amperage draw for each unit depends on the accessories supplied with the unit/system.

FRYMASTER FPD65 SERIES GAS FRYERS
CHAPTER 2: IMPORTANT INFORMATION

2.5 Pre-Installation (cont.)

B. Clearances: The fryer area must be kept free and clear of all combustibles. This unit is design-certified for the following installations:

1. Commercial installation only (not for household use).
2. Non-combustible floor installation equipped with factory-supplied 6-inch (15-cm) adjustable legs or 5-inch (13-cm) casters;
3. Combustible construction with a minimum clearance of 6-inches (15-cm) side and 6-inches (15-cm) rear, and equipped with factory-supplied 5-inch (13-cm) casters.

C. Installation Standards

<p>1. <u>U.S. installations must meet:</u></p> <p>American National Standard Institute ANSI Z83.11 American Gas Association 8501 E. Pleasant Valley Road Cleveland, OH 44131</p> <p>National Electrical Code ANSI/NFPA #70 American National Standard Institute 1430 Broadway New York, NY 10018</p> <p>NFPA Standards #96 and #211 National Fire Protection Association 470 Atlantic Avenue Boston, MA 02110</p>	<p>2. <u>Canadian installations must meet:</u></p> <p>CAN 1-B149 Installation Codes Canadian Gas Association 55 Scarsdale Road Don Mills, ONT, M3B 2R3</p> <p>Canadian Electric Code c22.1, part 1 Canadian Standards Association 178 Rexdale Blvd. Rexdale, ONT, M9W 1R3</p>
---	---

FRYMASTER FPD65 SERIES GAS FRYERS
CHAPTER 2: IMPORTANT INFORMATION

2.6 Air Supply and Ventilation

 **DANGER**

This appliance must be installed with sufficient ventilation to prevent the occurrence of unacceptable concentrations of substances harmful to the health of personnel in the room in which it is installed.

Keep the area around the fryer clear to prevent obstruction of combustion and ventilation airflow as well as for service and maintenance.

- A. Do not connect this fryer to an exhaust duct.
- B. Correct installation and adjustment will ensure adequate airflow to the fryer system.
- C. A commercial, heavy-duty fryer must vent its combustion wastes to the outside of the building. A deep-fat fryer must be installed under a powered exhaust hood, or an exhaust fan must be provided in the wall above the unit, as exhaust gas temperatures are approximately 800-1000°F (427-538°C). Check air movement during installation. Strong exhaust fans in the exhaust hood or in the overall air conditioning system can produce slight air drafts in the room.
- D. Do not place the fryer's flue outlet directly into the plenum of the hood, as it will affect the gas combustion of the fryer.
- E. Never use the interior of the fryer cabinet for storage or store items on shelving over or behind the fryer. Exhaust temperatures can exceed 800°F (427°C) and may damage or melt items stored in or near the fryer.
- F. Adequate distance must be maintained from the flue outlet of the fryer(s) to the lower edge of the filter bank. Per NFPA Standards No. 96, a minimum of 18-inches (45-cm) should be maintained between the flue(s) and the lower edge of the exhaust hood filter.
- G. Filters and drip troughs should be part of any industrial hood, but consult local codes before constructing and installing any hood. The duct system, the exhaust hood and the filter bank must be cleaned on a regular basis and kept free of grease.

2.7 Equipment Installed at High Altitudes

- A. The fryer input rating (BTU/hr) is for elevations up to 2,000 feet (610-m). For elevations above 2,000 feet (610-m), the rating should be reduced four percent for each additional 1,000 feet (305-m) above sea level.
- B. The correct orifices are installed at the factory if operating altitude is known at time of the customer's order.

FRYMASTER FPD65 SERIES GAS FRYERS

CHAPTER 3: INSTALLATION

3.1 Installing the Fryer

Decathlon 65 Series fryer systems are shipped in sections. The fryers are uncrated, removed from pallets and assembled together. Important aspects during assembly include aligning and connecting the drain system, oil return system, rinse-line system (where applicable), oil-return switch wiring harness and fryer cabinets. Slight modifications to connecting hardware may be required when assembling the system. The instructions below provide step-by-step instructions to assist the installer in assembly. For this procedure, the fryers are numbered from *right to left* as follows: Fryers #1, #2, #3, #4, #5 and #6 (where applicable).

1. Open the doors of the filtration fryer cabinet. Remove filter pan from the cabinet. Uncrate fryers and remove the pallet supports. Install ramps and slowly roll the fryer(s) off the pallets.

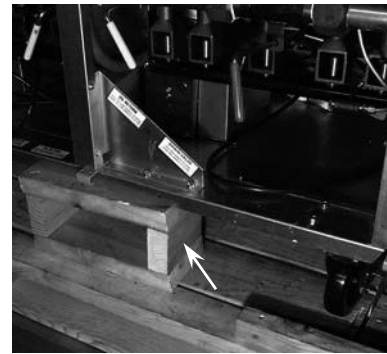

Figure 1. Remove pallet supports (arrow) before removing fryers from pallets.

2. Remove door from fryers to be connected by lifting the door upward and removing the door pin from the bottom hinge. Remove slip-nuts from drain-tees on fryers being connected, lubricate O-rings with vegetable oil and install on drainpipe (Fig. 2). **Use care not to damage the slip-nut O-rings when installing slip-nut on drainpipe.** Insert the drainpipe into the fryer drain-tee (Fig. 3). Screw slip-nut onto the tee but do not tighten at this time. Position fryers being connected within 6 inches of each other, near the permanent installation area. Guide the drainpipe through the opposite fryer cabinet opening as the cabinets are positioned.

Properly align the drainpipe evenly between the two drain-tees using the "blue" marks on the tube ends to prevent leaks and/or blocked drain valves.

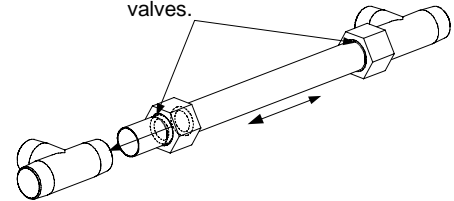

Figure 2. Slip-nut/drainpipe detail.

NOTE: When the slip nuts are tightened, the "blue" marks on each end of the drainpipe should align to the outside edge of each slip nut.



Figure 3. Insert drainpipe section into fryer drain-tee before pushing fryers together (arrow). Do this as required for all cabinets being assembled.

FRYMASTER FPD65 SERIES GAS FRYERS

CHAPTER 3: INSTALLATION

3.1 Installing the Fryer (cont.)

3. Connect red/white or red/yellow wires (Figure 4, left) between fryer sections being assembled (Figure 4, right, arrow). Oil-return will not operate properly if these wires are not connected.

NOTE: On systems shipped in three or more sections, additional wiring between cabinets will exist. Ensure all wires are connected before completing cabinet assembly.

4. Remove the lower back panel-strips on fryers being assembled to gain access to the oil return and rinse-line connections (Figure 5, arrows). Back removal may not be required on some systems.
5. Slowly push the two cabinets together. Ensure the drainpipe and slip-nut are aligned with the drain-tee on the opposite fryer section. Ensure the oil-return and rinse-hose connections (where applicable) on each fryer section are aligned. Ensure oil-return switch wires between cabinet sections are not pinched when the cabinets are brought together. Pull excess wire through the opposite fryer side as the cabinets are brought together. Secure excess wire inside cabinet with a wire tie.
6. With the cabinets together, insert the drainpipe into the opposite fryer drain-tee and position it evenly between the fryers being connected. Connect the oil-return and rinse-lines by accessing the oil return union through the lower fryer-back openings. Connect all fittings, but do not tighten at this time.
7. Align the cabinet connection holes, front and back (Figure 6, arrow). Connection hardware is included in the accessories pack. Insert bolts and install nuts, but do not tighten. If holes do not align, use a 3/16" drill-bit and drill through the misaligned hole.
8. Install the frypot joiner strip between cabinet sections (Figure 7; also see factory-installed strips on two-battery cabinet sections).

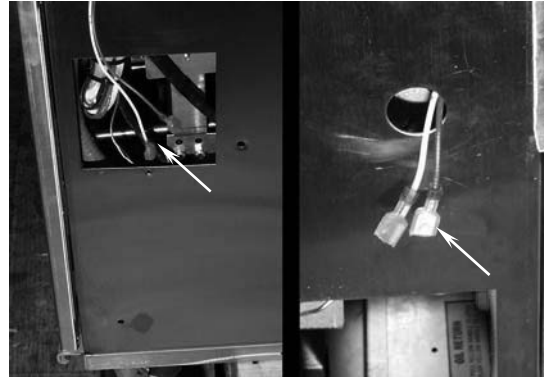

Figure 4. Oil return wires between sections must be connected for oil-return operation.

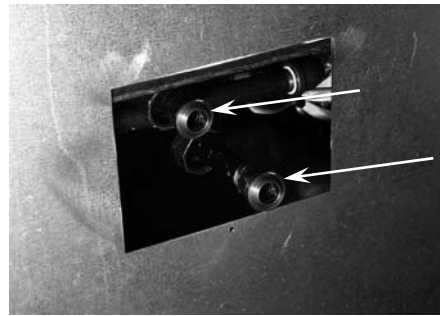

Figure 5. Oil return and rinse-line (where applicable) connections.

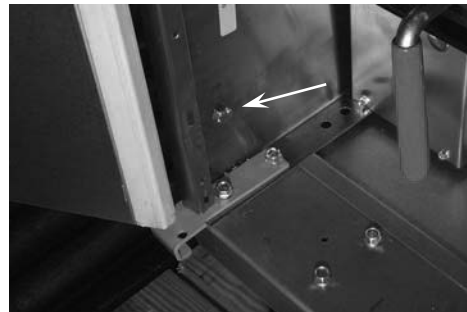

Figure 6. Cabinet connection locations inside cabinet sections (front shown).



Figure 7. Install joiner strip(s) after fryers are connected.

FRYMASTER FPD65 SERIES GAS FRYERS

CHAPTER 3: INSTALLATION

3.1 Installing the Fryer (cont.)

9. Install the front connecting post on the connected cabinets (Figure 8; see factory-installed posts on two-battery fryer sections).

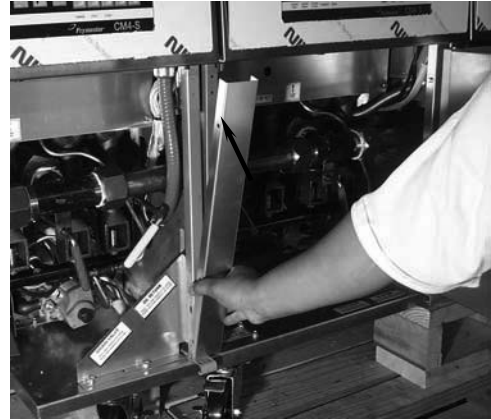

Figure 8. Installing front connecting post on connected fryer sections.

10. Complete installation of topcap battering strips after the front connecting post has been installed (Figure 9).

NOTE: Systems shipped in three or more sections will require the installation of topcaps and other components prior to installing topcap-battering strips. See Topcap Installation Instructions for these systems.

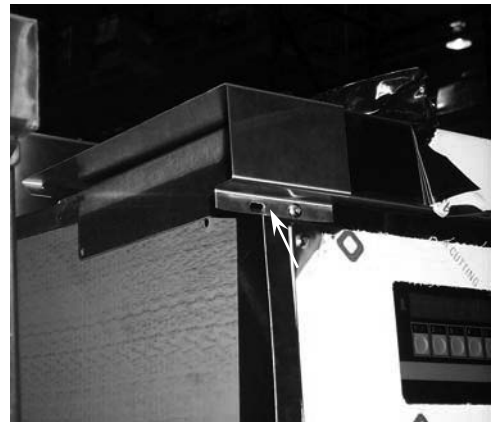

Figure 9. Complete installation of topcap battering strips (arrow) after installing front connecting post(s) on connected fryers.

11. Install the rear connecting plate (Figure 10). Remove four screws from the cabinet backs (Figure 10, arrows), install connecting plate and replace screws. Connection strips vary from system to system.

12. **At the fryer front:** Tighten the drain manifold slip-nuts. Install doors removed at the beginning of assembly. **At the fryer back:** Tighten the oil-return line and rinse-line (where applicable) union(s).

13. Reinstall filter pan after fryer start-up has been performed (boil-out, burner adjustment, etc.) **NEVER ALLOW WATER OR BOILOUT SOLUTION INTO FILTER SYSTEM.**

Check all connections for leaks. Ensure all components operate properly.

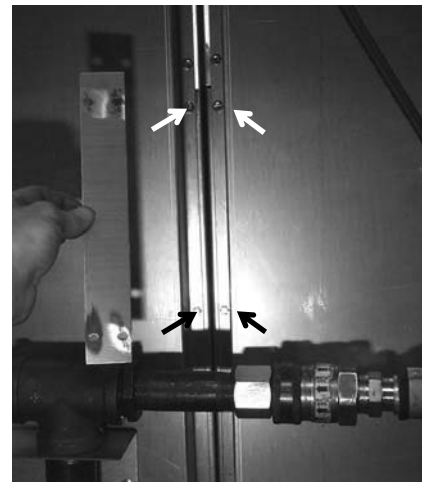

Figure 10. Install rear connecting plate.

**FRYMASTER FPD65 SERIES GAS FRYERS
CHAPTER 3: INSTALLATION**

3.1 Installing the Fryer (cont.)

 DANGER

Fryers must be at room temperature and empty of oil during movement to avoid damage and possible bodily injury.

 DANGER

Hot shortening can cause severe burns. Avoid contact. Under all circumstances, oil must be removed from the fryer before attempting to move it to avoid oil spills, and the falls and severe burns that could occur. This fryer may tip and cause personal injury if not secured in a stationary position.

3.2 Gas Connections

 DANGER

Before connecting new pipe to this appliance the pipe must be blown out thoroughly to remove all foreign material. Foreign material in the burner and gas controls will cause improper and dangerous operation.

NATIONAL CODE REQUIREMENTS

This equipment is to be installed in compliance with the Basic Plumbing Code of the Building Officials and Code Administrators International, Inc. (BOCA) and the Food Service Sanitation Manual of the U.S. Food and Drug Administration.

This equipment is manufactured to use the type of gas specified on the rating plate attached to the door. Connect equipment stamped "NAT" only to natural gas and that stamped "PRO" only to LP (Propane) gas.

Notice

Installation shall be made with a gas connector that complies with national and local codes. Quick disconnect devices, if used, shall likewise comply with national and local codes.

 DANGER

The fryer MUST be connected to the gas supply specified on the rating and serial number plate located on the back of the fryer door.

FRYMASTER FPD65 SERIES GAS FRYERS
CHAPTER 3: INSTALLATION

3.2 Gas Connections (cont.)

⚠ DANGER

If gas odors are detected, the gas supply MUST be shut off at the main shut-off valve. The local gas company or FASC should be contacted immediately to rectify the problem.

- A. The gas supply (service) line must be the same size or greater than the fryer inlet line. This fryer system is equipped with three 1" (28 mm) female inlets (one inlet per two fryers). The gas supply line must be sized to accommodate all the gas-fired equipment that may be connected to that gas supply. Consult your contractor, gas company, supplier, or other knowledgeable authorities.

Recommended Gas Supply Line Sizes			
Gas Types	Number of Fryers		
	1	2 to 3	4 or more (*)
Natural Gas	3/4" (22 mm)	1" (28 mm)	1-1/4" (35 mm)
Propane Gas	1/2" (15 mm)	3/4" (22 mm)	1" (28 mm)

(*) When exceeding 18 feet for a configuration of more than four fryers, it is necessary to provide a 1-1/4" (35 mm) rigid gas connection.

⚠ DANGER

All connections must be sealed with a joint compound suitable for the gas being used and all connections must be tested with a solution of soapy water before lighting any pilots.

Never use matches, candles, or any other ignition source to check for leaks. If gas odors are detected, shut off the gas supply to the appliance at the main shut-off valve and immediately contact the local gas company or an authorized service agency for service.

⚠ DANGER

"Dry-firing" your unit will cause damage to the frypot and can cause a fire. Always ensure that melted shortening, cooking oil or water is in the frypot before firing the unit.

- B. Rigid Connections: Check any installer-supplied intake pipe(s) visually and clean threading chips, or any other foreign matter before installing into a service line. If the intake pipes are not clear of all foreign matter, the orifices will clog when gas pressure is applied. Seal pipe joints with a sealant resistive to LP gas. When using thread compound on gas piping, use very small amounts and only on male threads. Use a pipe thread compound that is not affected by the chemical action of LP gases. **DO NOT** apply thread compound to the first two pipe threads—doing so will cause clogging of the burner orifices and control valve.

FRYMASTER FPD65 SERIES GAS FRYERS
CHAPTER 3: INSTALLATION

3.2 Gas Connections (cont.)

- C. Manual shut-off valve: This gas service supplier-installed valve must be installed in the gas service line ahead of the fryers in the gas stream and in a position where it can be reached quickly in the event of an emergency.
- D. Regulating Gas Pressure: The fryer and shut-off valve must be disconnected from the gas supply during any pressure testing of the system.
1. External gas regulators are not normally required on this fryer. A safety control valve protects the fryer against pressure fluctuations. If the incoming pressure is in excess of ½" PSI (3.45 kPa/35 mbar), **a step-down regulator will be required.**

 **DANGER**

When pressure-testing incoming gas supply lines, disconnect the fryer from the gas line if the test pressure is ½" PSI [3.45 kPa (14 inches W.C.)] or greater to avoid damage to the fryer's gas piping and gas valve(s).

- E. Manifold Pressure: Your local service technician should check the manifold pressure with a manometer.
1. Check the rating plate for specific manifold gas pressures. Natural gas units normally require 4" W.C., and propane units normally require 11" W.C. gas pressure.
 2. Double check the arrow forged into the bottom of the regulator body, which shows gas flow direction. It should point downstream towards the fryers. The air vent cap is also part of the regulator and should not be removed.
 3. If a vent line from the gas pressure regulator is used, it should be installed in accordance with local codes or in the absence of local codes, with the National Fuel Gas Code, ANSI Z223.1-(latest edition).

 **WARNING**

Use a diluted soap solution to find potentially dangerous gas leaks when making new connections.

- F. Regulators can be adjusted in the field, but it is recommended that they not be unless the part is known to be out of adjustment or serious pressure fluctuations are found to exist and can be solved no other way.
- G. Only qualified service personnel should make adjustments to the regulators.
- H. Orifices: The fryer can be configured to operate on any available gas. The correct safety control valve, appropriate gas orifices, and pilot burner are installed at the factory. While the valve can be adjusted in the field, only qualified service personnel should make any adjustments with the proper test equipment.

FRYMASTER FPD65 SERIES GAS FRYERS
CHAPTER 3: INSTALLATION

3.2 Gas Connections (cont.)

I. Flexible Couplings, Connectors and Casters:

1. If the fryer is to be installed with flexible couplings and/or quick-disconnect fittings, the installer must use a heavy-duty AGA design-certified commercial flexible connector of at least 1" NPT (with suitable strain reliefs), in compliance with the Standard for Connectors for Movable Gas Appliances, ANSI Z21.69-(latest edition) and Addenda Z21.69a-(latest edition). Quick disconnect devices must comply with the Standard for Quick-Disconnect Devices for Use with Gas Fuel, ANSI Z21.41-(latest edition).

 **WARNING**

**Do not attach accessories to this fryer unless fryer is secured from tipping.
Personal injury may result.**

2. The fryer must be restrained by means independent of the flexible coupling or connector in order to limit the movement of the fryer. Clips are located on the back panel of the fryer for the attachment of restraints.
 3. If disconnection of the restraint is necessary, this restraint must be reconnected after the fryer has been returned to its originally installed position.
- J. After hook-up, bleed the gas line of air to ensure that the pilot light will ignite quickly.

3.3 Adjustments/Adaptation To Different Gases

- A. Proper operation of Frymaster/Dean gas fryers requires operator to inspect the following adjustments in terms of:
1. Gas inputs and pressures.
 2. Voltage and polarities of electrical power supplies.
- B. Frymaster/Dean gas fryers are manufactured to use the type of gas and pressure specified on the rating plate. When changing to a different gas, **adaptation must be performed by qualified personnel.** Failure to use qualified personnel will void the Frymaster/Dean warranty.

FRYMASTER FPD65 SERIES GAS FRYERS
CHAPTER 3: INSTALLATION

3.3.1 Specifications

3.3.1.1 Adjustments to Different Gas Types

Gas Adjustments		
Gas Type	Natural	LP
Manifold Pressure†	4" W.C.*/10 mbar*	11" W.C.*/27.5 mbar*
Orifice Diameter	Model Specific	Model Specific
Burner Marking	None	None
Pilot Marking	26N (P/N 810-0811)	16LP (P/N 810-2400)
<small>* Gas pressure may vary per fryer model and altitude. Check the rating plate for specific gas pressures.</small>		

NOTE: Outlet gas pressure must be adjusted strictly within the above requirements 5 to 10 minutes after the appliance is operating.

† For controls and adjustments, please refer to the "gas valve" illustration on page 3-9. (Pilot Flame Adjustment: Turn the pilot adjustment screw clockwise/counter-clockwise until the desired flame-volume is achieved.)

3.3.2 Gas Conversion Procedures

 **DANGER**

This appliance was configured at the factory for a specific type of gas. Converting from one gas type to another requires the installation of specific gas-conversion components.

Switching to a different type of gas without installing the proper conversion components may result in fire or explosion. NEVER ATTACH THIS APPLIANCE TO A GAS SUPPLY FOR WHICH IT IS NOT CONFIGURED!

Conversion of this appliance from one type of gas to another should only be performed by qualified, licensed, and authorized installation or service personnel, as defined in Section 1.6 of this manual.

FRYMASTER FPD65 SERIES GAS FRYERS

CHAPTER 3: INSTALLATION

3.3.2 Gas Conversion Procedures (cont.)

Contact factory with the following information when performing conversions:

- Fryer Serial Number
- Fryer Model Number
- Gas Type
- Operating Altitude

Conversions can only be executed by qualified, factory-authorized personnel.

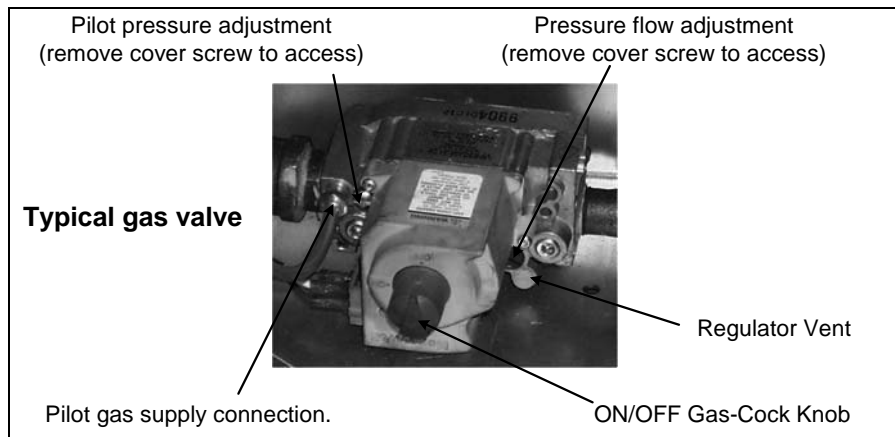

3.4 Electrical Connections

The fryer when installed must be electrically grounded in accordance with local codes, or in the absence of local codes, with the National Electrical Code, ANSI/NFPA 70-(latest edition).

⚠ DANGER

This fryer is equipped with three-prong (grounding) plugs for protection against electrical shock and must be plugged directly into a properly grounded, three-prong receptacle. DO NOT CUT, REMOVE, OR OTHERWISE BYPASS THE GROUNDING PRONGS ON THESE PLUGS!

The rating plate and wiring diagram are located inside the front door. The fryer is equipped with a 120VAC single-phase 60-hertz system (Domestic), or 230VAC single-phase 50-hertz system (International/CE). Do not cut or remove the ground prong from any of the power cord plugs. Do not attempt to use the fryer during a power outage.

⚠ DANGER

This appliance requires electrical power for operation. Place the gas control valve in the OFF position in case of a prolonged power outage. Do not attempt to operate this appliance during a power outage.

FRYMASTER FPD65 SERIES GAS FRYERS

CHAPTER 4: FRYER OPERATIONS

4.1 Initial Start-up

⚠ WARNING

The on-site supervisor is responsible for ensuring that operators are made aware of the inherent hazards of operating a hot oil frying system, particularly the aspects of system operation, oil filtration, draining and cleaning procedures.

Cleaning: New units are wiped clean with solvents at the factory to remove any visible signs of dirt, oil, grease, etc. remaining from the manufacturing process, then coated lightly with oil. Before any food preparation, wash thoroughly with hot, soapy water to remove any film residue and dust or debris then rinse out and wipe dry. Also wash any accessories shipped with the unit. Close the drain valve completely and remove the crumb screen covering the heating tubes. Ensure the screws holding the thermostat and high-limit control sensing bulbs into the frypot are tight.



Typical high-limit/sensor probe locations and mounting hardware.

⚠ WARNING

Do not bang fry baskets or other utensils on the fryer's joiner strip. The strip is present to seal the joint between the frypot. Banging fry baskets on the strip to dislodge shortening will distort the strip, adversely affecting its fit. It is designed for a tight fit and should only be removed for cleaning.

⚠ DANGER

Never operate this appliance with an empty frypot. The frypot must be filled with water or cooking oil/shortening before lighting the burners. Failure to do so will damage the frypot and may cause a fire.

⚠ WARNING

When checking for burner ignition or performance, do not get too close to the burners. Slow ignition can cause possible flashback, increasing the potential for facial and body burns.

FRYMASTER FPD65 SERIES GAS FRYERS

CHAPTER 4: FRYER OPERATIONS

4.1.1 Pilot Lighting Procedures, Electronic Ignition Systems

Initial Pilot Lighting: All Frymaster/Dean fryers are tested, adjusted and calibrated to sea level conditions before leaving the factory. Adjustments to assure proper operation of pilot may be necessary on installation to meet local conditions, low gas pressure, differences in altitude and variations in gas characteristics. These adjustments correct possible problems caused by rough handling or vibration during shipment, and are to be performed only by qualified service personnel. These adjustments are the responsibility of the customer and/or the dealer and are not covered by the Frymaster/Dean warranty.

The inlet pipe at the lower rear of the fryer brings incoming gas to the pilot safety control valve, then to the pilot and main burners. The pilot is located high in the cabinet center, at the base of the frypot.

 **WARNING**

Never use a match or taper to light pilot on this ignition system.

1. Turn gas "ON".
2. Turn electric power "ON" with the appropriate rocker switch or controller/computer.
3. The ignition module will energize the pilot gas supply and the ignitor. The ignitor spark will ignite the pilot gas. The presence of the pilot flame is then proved by a flame sensor, which sends a signal to the main gas supply, opening the valve. The operating thermostat or computer/controller controls the fryer after ignition.

 **WARNING**

In the event of prolonged power failure, the ignition module will shut down and lock out the system. Turn the unit power "OFF" and them back "ON" after power has been re-established.

4. If the pilot flame fails, the ignition module will shut down and lock out the system. To restart, turn the electric power "OFF", wait approximately 5 minutes for the system to recycle itself, then turn the power "ON" again. Repeat Steps 1-3.

**FRYMASTER FPD65 SERIES GAS FRYERS
CHAPTER 4: FRYER OPERATIONS**

4.2 Boil-Out Procedure

 DANGER

Never leave the fryer unattended during the boil-out process. If the boil-out solution boils over, turn the fryer off immediately and let the solution cool for a few minutes before resuming the process. To lessen the chance of boil over, turn the fryer's gas valve knob to the PILOT position occasionally.

 WARNING

Do not drain boil-out solution into a shortening disposal unit, a built-in filtration unit, or a portable filter unit. These units are not intended for this purpose, and will be damaged by the solution.

 DANGER

Remove all drops of water from the frypot before filling with cooking oil or shortening. Failure to do so will cause spattering of hot liquid when the oil or shortening is heated to cooking temperature and may cause injury to nearby personnel.

- A. Pour cleaning solution into the frypot and add water to the bottom OIL LEVEL line scribed in the back of the frypot.
- B. Operating thermostat-equipped fryers: Set dial/temperature controller to 225°F (107°C), just above that of boiling water.
- C. Filtration/Boil-Mode equipped fryers: Turn fryer power switch to "ON". Press the fryer-reset switch (if applicable). Turn the boil-out switch "ON".

 CAUTION

If the pilot and main burner go out, the fryer(s) MUST be left completely shut down at least 5 minutes before lighting.

- D. The main burner will ignite.
- E. When the solution nears boiling point, reset the temperature controller to 200°(93°C).
- F. The burners should shut off just as the water starts to boil.

 CAUTION

Do not leave fryer unattended. The boil-out solution may foam and overflow if fryer is left unattended. Press ON/OFF switch to the "OFF" position (Filtration/Boil-Mode equipped fryers) or reduce temperature (Operating Thermostat equipped fryers) to control this condition.

FRYMASTER FPD65 SERIES GAS FRYERS
CHAPTER 4: FRYER OPERATIONS

4.2 Boil-Out Procedure (cont.)

- G. The burners will heat the boil-out solution to a simmer. Simmer the solution for approximately 45 minutes. Wearing protective gloves, scrub the sides of the frypot and the tubes with the L-shaped Teflon brush, being careful not to disturb the temperature sensing probes and the high-limit thermostat.
- H. Do not allow the water level to decrease below the bottom OIL LEVEL line in frypot during boil-out operation.

 **WARNING**

Water or boil-out solution MUST not be allowed to drain into the filter pan or filter system. Irreversible damage will result if water is allowed into the system.

- I. After boil out is complete, turn the computer off. Drain the solution from the frypot. Place a metal stockpot of sufficient size to safely hold the entire contents of the frypot under the drain port to collect the water/boil-out solution. Do not allow water or boil-out solution to drain into the filter pan. The filter pump is not designed for water operation, and will be irreparably damaged (see warning statement above).
- J. Close the drain, add fresh water (without boil-out solution) and wash all surfaces of the frypot. Drain again.
- K. Refill the frypot with fresh water and vinegar to neutralize any residual boil-out solution. Wash all surfaces of the frypot. Drain completely and wipe down all surfaces of the frypot to completely remove all water.

Computer-equipped fryers: See computer manual for boil-out programming and follow the above procedures for boil-out.

 **DANGER**

Do not go near the area directly over the flue outlet while the fryer is operating.

Always wear oil-proof, insulated gloves when working with the fryer filled with hot oil.

Always drain hot oil into a metal stockpot of sufficient size to safely hold the entire contents of the frypot.

FRYMASTER FPD65 SERIES GAS FRYERS
CHAPTER 4: FRYER OPERATIONS

4.3 Final Preparation

⚠ WARNING

NEVER set a complete block of solid shortening on top of heating tubes. To do so will damage the heating tubes and frypot, and void the warranty.

4.3.1 Filling Fryer with Cooking Oil/Shortening

- A. When using a liquid shortening (cooking oil), fill the fryer to the bottom OIL LEVEL line scribed into the back of the frypot.
- B. When using a solid shortening, cut it into small pieces and pack it below the heat tubes, between the tubes and on top of the tubes, leaving no air spaces around the tubes. Do not disturb or bend the probe sensing bulbs.
- C. Press the computer on/off switch to "ON". The burners will initially operate in the MELT CYCLE mode until the shortening reaches 180°F. It will then automatically switch to normal operation.
- D. When the frypot is filled and the shortening is melted, carefully replace the crumb screen over the heat tubes. Wear oil-proof insulated gloves to avoid the potential for burn injury when placing crumb screen in frypot.

For additional computer instructions, see computer manual that came with frying system.

FRYMASTER FPD65 SERIES GAS FRYERS

CHAPTER 5: FILTRATION OPERATION

WARNING

Drawings and photos used in this manual are intended to illustrate operational, cleaning and technical procedures and may not conform to on-site management operational procedures.

5.1 General

Frymaster FPD65 Series gas fryer filter systems come equipped with a filter-leaf assembly, which eliminates the need for filter paper. Filter powder is used to enhance the filtration process.

5.2 Filtration Preparation

On initial installation and before each use, remove all loose parts from the filter, wash the filter pan and all accessories in hot, soapy water and dry thoroughly.

5.2.1 Assembling the Filter

Frymaster FPD65 Series filter systems incorporate a filter-leaf assembly, in which a fine mesh screen is used to filter impurities and debris from the oil. The oil is pumped through the screen and then returned to the frypot.

Assemble the filter pan as follows (see illustration below):

1. Filter pan assembly.
2. Filter-leaf assembly.
3. Crumb screen.
4. Front filter pan cover.
5. Rear filter pan cover.

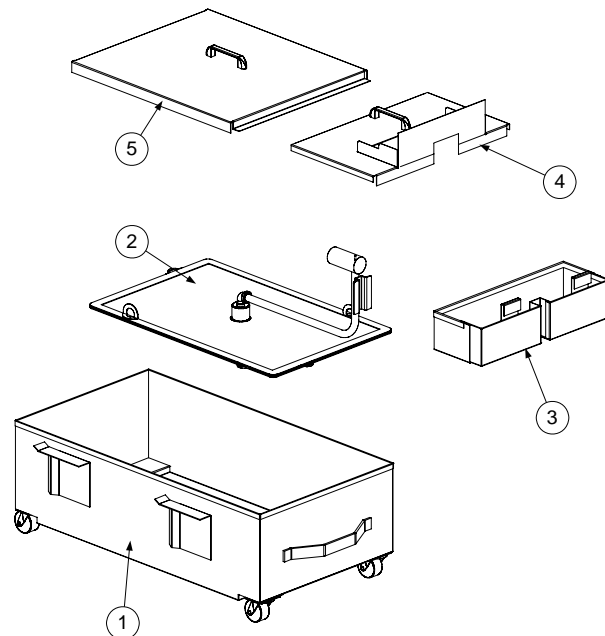

FRYMASTER FPD65 SERIES GAS FRYERS

CHAPTER 5: FILTRATION OPERATION

5.2.1 Assembling the Filter (cont.)

Assemble the filter as follows:

1. Remove the filter pan covers.



Filter pan with covers removed.

2. Place the filter leaf assembly in the bottom of the filter pan, ensuring the filter disconnect is properly placed in the filter pan slot. Support the screen assembly by holding the supply pipe during installation.



The bracket fits into a slot in the pan.

3. Ensure the filter screen lies flat in the bottom of the pan and the supply connection bracket is properly positioned in the pan slot before proceeding.



Filter leaf properly positioned in filter pan.

FRYMASTER FPD65 SERIES GAS FRYERS

CHAPTER 5: FILTRATION OPERATION

5.2.1 Assembling the Filter (cont.)

4. Place the crumb tray in filter pan.

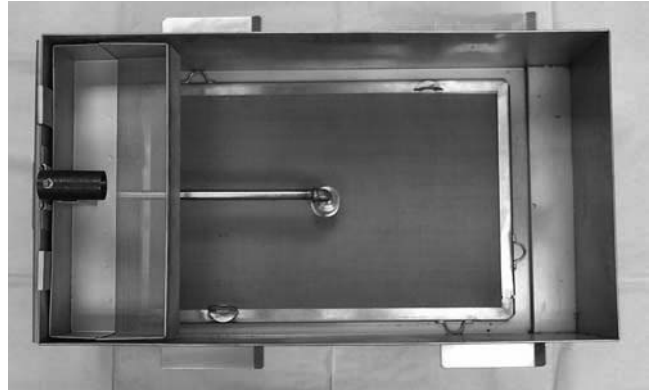

Crumb screen placement in filter pan.

5. Replace the pan covers and install the filter pan into the cabinet. Ensure the connections are fully engaged. Ensure the filter pan opening is directly under the drain tubes to avoid splashing hot oil. The fryer is ready for filtering.



The filter pan slides under the fryer (above), connecting with a slip fitting (right). The slip fitting is located between the drain tubes (above, arrow).



FRYMASTER FPD65 SERIES GAS FRYERS
CHAPTER 5: FILTRATION OPERATION

5.2.2 Disassembling/Assembling and Cleaning an Optional Filter Leaf

Follow these steps to clean a leaf-style filter:

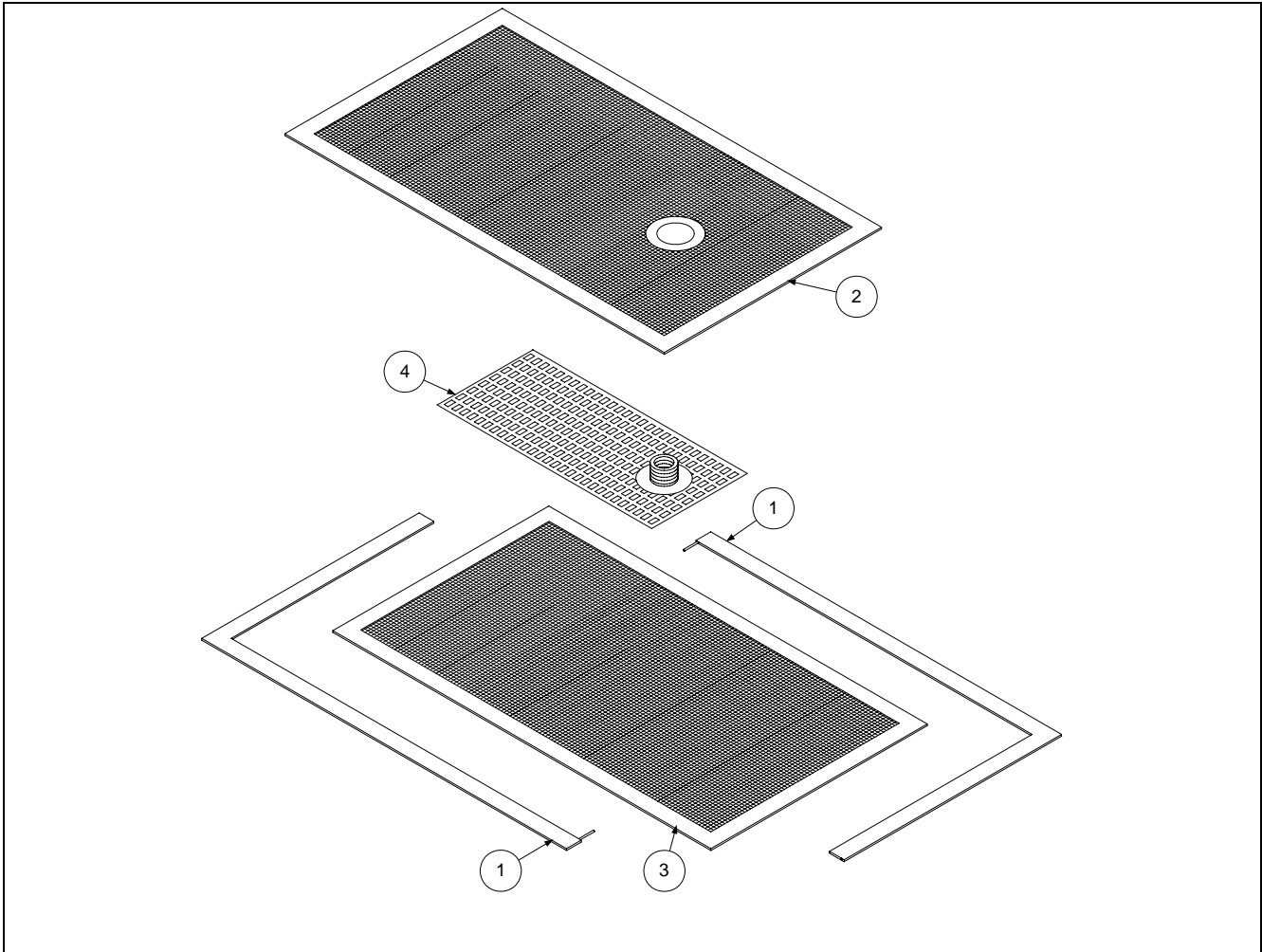

Filter Leaf Disassembly/Assembly

Grasp the seal frame near each corner at the locking tab (1) and pull frame apart. The seal frame will separate into two pieces. Separate the top and bottom screens (2 & 3) and remove the grid (4). Assemble in reverse order.

FRYMASTER FPD65 SERIES GAS FRYERS

CHAPTER 5: FILTRATION OPERATION

Cleaning the Filter Leaf Assembly

Clean the two seal frame pieces, screens and grid using a good quality degreaser and hot water from a spray nozzle. The groove in the seal frame pieces can be cleaned with the edge of a Scotch-Brite or similar cleaning pad.

At each scheduled boil out, disassemble the filter leaf as described in Section 5.7.1 and place in the frypot filled with boil-out solution. Follow the boil-out procedure in Section 4.4.1, including placing the filter leaf in the vinegar solution to neutralize boil-out residue, and clean water to rinse away vinegar residue.

Allow all filter leaf components to air dry or thoroughly dry with paper towels.

5.3 Daily Filtration Operation

 **WARNING**

Use caution and wear proper protective clothing. The oil to be filtered is at or near 350°F (177°C). Ensure all hoses are connected properly and drain handles are in their proper position prior to operating any switches or valves. Failure to do this can result in severe burns.

 **WARNING**

Drawings and photos used in this manual are intended to illustrate operational, cleaning and technical procedures and may not conform to on-site management operational procedures.

5.3.1 General Overview

The filter pump is turned on only after the oil is brought to operating temperature and drained into the prepared filter pan. The filter motor is then engaged and oil is drawn through the filter leaf assembly and pumped back into the frypot. The frypot drain valve remains open during the filtering process. The oil is cycled through the filter leaf assembly for approximately 10 minutes (see computer section for specific instructions). At the end of 10 minutes, the drain valve is closed, allowing the oil to pump back into the frypot. The pump should run for 15-30 seconds after bubbles appear in the frypot to ensure all oil or shortening is pumped from the drain pan and the oil-return lines. The frypot oil level should return to the top OIL LEVEL line. If not, add fresh oil or shortening to obtain the proper level. Remember, the oil is at operating temperature during all filtration procedures.

The filter pump can be activated with a manual On/Off switch located under the fryer control panel if the oil-return, drain-flush or wand/dispose valves fail to activate the pump when opened. Contact an authorized service technician immediately for repair.

Refer to specific store procedures for correct filter operation. Additional information can be found in the computer section of this manual.

FRYMASTER FPD65 SERIES GAS FRYERS

CHAPTER 5: FILTRATION OPERATION

5.3.2 Filtering Tools

Assemble tools to be used for filtering. These are supplied with the filter starter kit included with the fryer/filter system:

- Frypot/Filter Brush– used to clean frypot and filter pan sides and bottom, heating tubes, and to dislodge sediment during filtration or shortening change.
- Clean-Out Rod– used to dislodge heavy debris in the drain tube (when needed).

The following tools are not required, but are recommended:

- Measuring Cup– used to measure filter powder.
- Fine Mesh Skimmer– used to remove large debris.

Note: Prior to proceeding, put on safety goggles, neoprene gloves and heavy vinyl apron.

NOTICE

Follow specific store procedures when filtering the fryer. In the event store procedures are not available, the following instructions can be followed until specific store procedures are obtained.

WARNING

Filter **ONLY** one frypot at a time. The filter pan is designed to hold the contents of one frypot **ONLY**.

FRYMASTER FPD65 SERIES GAS FRYERS
CHAPTER 5: FILTRATION OPERATION

5.4 Operating the Filter

5.4.1 Filter Operation

⚠ CAUTION
NEVER operate the filter unit unless cooking oil is at operating temperature [$\sim 350^{\circ}\text{F}$ ($\sim 177^{\circ}\text{C}$)].

1. Remove fry baskets from frypot. Prior to filtering, skim any large debris from the oil with the fine mesh skimmer. Use extreme caution, as oil is at or near operating temperature [$\sim 350^{\circ}\text{F}$ ($\sim 177^{\circ}\text{C}$)]. Use a metal scraper to gently remove debris from frypot walls above shortening level.



Prior to filtering, skim any large debris from oil in frypot.

2. Pour 12 ounces by volume of filter powder into the vat. Carefully stir the powder into the oil with the fine mesh skimmer.

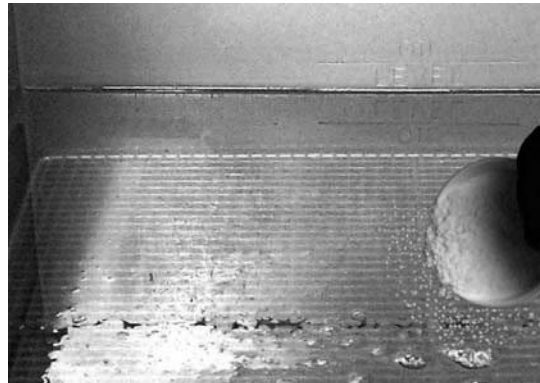

Adding filter powder to vat prior to filtering.

3. Ensure the oil is at operating temperature ($\sim 350^{\circ}\text{F}/177^{\circ}\text{C}$). Open the fryer drain valve. Allow the oil to drain into the filter pan. The computer will display *OPEN DRAIN*.

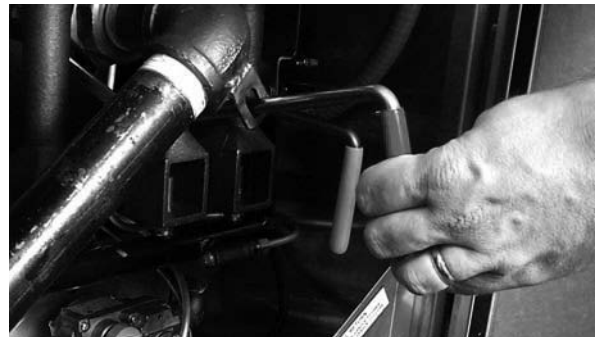

Pull red handle to open drain valve and allow hot shortening to drain into filter pan.

FRYMASTER FPD65 SERIES GAS FRYERS

CHAPTER 5: FILTRATION OPERATION

5.4.1 Filter Operation (cont.)

- When all the oil has drained from the frypot, connect the hose-wand assembly to the disconnect valve in the fryer cabinet. **DO NOT ACTIVATE FILTER PUMP UNTIL THE HOSE HAS BEEN PROPERLY CONNECTED.** Ensure the hose-disconnect is properly connected before proceeding. Remove the frypot wire rack prior to rinsing frypot.



Hose/wand disconnect properly connected to disconnect valve in fryer cabinet (orientation of disconnect may vary according to system).

- Place the hose wand into the frypot being filtered and activate the rinse valve by turning the blue handle to "WAND" (where applicable), or by pressing the manual bypass switch (systems without oil disposal system). The filter pump will activate and oil will start flowing through the rinse hose.



After the hose wand end is properly positioned in the frypot, activate the filter pump by turning the blue handle to "WAND" (where applicable).

- Hold the wand inside the frypot at a 45-degree angle while the rinse valve is opened.
- Use the wand to rinse debris from the frypot for approximately 3 minutes. At the end of 3 minutes, the computer display will alternate from *OPEN DRAIN* to the timed countdown cycle (10 minutes). Turn the blue handle or the manual bypass switch to "OFF", and then close the drain valve (red handle). Disconnect and drain the hose of all shortening or oil. Hang hose upright to ensure no shortening remains in hose.



Use the wand to rinse debris from the frypot into the filter pan. Maintain a firm grip on the wand handle at all times.

FRYMASTER FPD65 SERIES GAS FRYERS

CHAPTER 5: FILTRATION OPERATION

5.4.1 Filter Operation (cont.)

8. Begin the filtering process by pulling the yellow handle to open the oil-return valve (this activates the filter pump automatically).



Begin the filtering process by pulling yellow handle to open oil return valve. Leave the drain valve (red handle) open during the filtering process.

9. Oil will begin to pump from the filter pan into the frypot. Allow the oil to circulate through the frypot for the remainder of the timed countdown (approximately 10 minutes). This process is known as "polishing".



Polishing the oil removes suspended particles, which increases the life of the oil.

10. The computer will display *FILL* at the end of the timed countdown. Replace the frypot grid rack. Close the red drain valve handle to begin refilling the frypot.



When the computer displays *FILL*, close the drain valve to begin refilling the frypot.

FRYMASTER FPD65 SERIES GAS FRYERS

CHAPTER 5: FILTRATION OPERATION

5.4.1 Filter Operation (cont.)

11. After all shortening is pumped back into the frypot, bubbles will form, indicating air in the oil return lines. Allow the shortening to bubble for 15-30 seconds to ensure all shortening is cleared from the return lines. An audible alarm will sound, indicating that the frypot is full. Push the yellow handle to close the oil return valve and deactivate the filter pump.



Allow the oil to bubble for 15-30 seconds to ensure evacuation of all oil in the return lines.

12. If the shortening level is low, add fresh shortening until the level is at the top OIL LEVEL line (the shortening is at operating temperature).

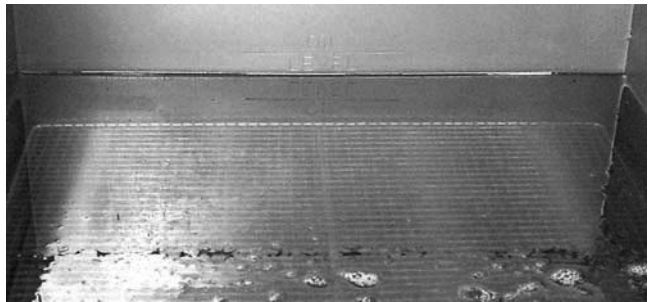

Add fresh shortening until the level is at the top OIL LEVEL line. DO NOT OVERFILL THE FRYPOT.

13. Do not allow crumbs to accumulate in the crumb tray. The crumb tray MUST be emptied into a fireproof container at the end of frying operations EACH day.

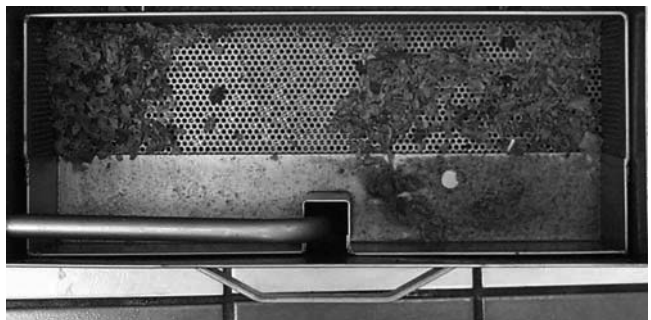

Empty the filter pan crumb tray into a fire-proof container at the end of frying operations each day. DO NOT ALLOW CRUMBS TO ACCUMULATE IN TRAY.

FRYMASTER FPD65 SERIES GAS FRYERS

CHAPTER 5: FILTRATION OPERATION

5.4.1 Filter Operation (cont.)

14. **OPTIONAL EQUIPMENT:** Drain-flushes are included on 5-battery and larger Frymaster FPD65 Series fryers. After filtering frypot farthest from the filter system for 10 minutes, close the oil return valve to stop the filtering process. Do not refill the frypot. Close the drain valve (red handle) on the frypot being filtered. Ensure all other valves (red and yellow handles) are closed. Pull the blue handle to open the flush valve (6-battery systems have two). After the drain line is clear of sediment (approximately 2 minutes), push the blue handle to close flush valve. Open the oil-return valve (yellow handle) to refill the frypot.

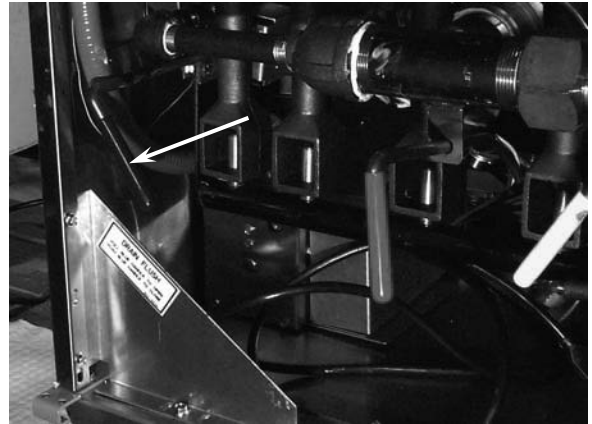

Left drain-flush handle location (arrow) for frypot #6.

15. **OPTIONAL EQUIPMENT:** Shortening Disposal: Follow store procedures when disposing of spent shortening. Ensure the Shortening Disposal System is properly connected and working properly before proceeding. Turn the blue handle on the wand/dispose valve to "DISPOSE" to start the disposal process. Turn the blue handle to "OFF" when the disposal process for that frypot is complete.

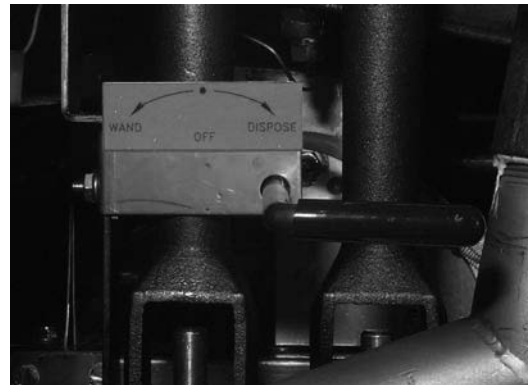

Blue handle in "DISPOSE" position. Turn handle to "OFF" after spent shortening is disposed of.

DANGER

The crumb tray in fryers equipped with a filter system must be emptied into a fireproof container at the end of frying operations each day. Some food particles can spontaneously combust if left soaking in certain shortening material.

WARNING

Do not bang fry baskets or other utensils on the fryer's joiner strip. The strip is present to seal the joint between the frypots. Banging fry baskets on the strip to dislodge shortening will distort the strip, adversely affecting its fit. It is designed for a tight fit and should only be removed for cleaning.

FRYMASTER FPD65 SERIES GAS FRYERS

CHAPTER 6: PREVENTATIVE MAINTENANCE

6.1 General

 **DANGER**

Never attempt to clean the fryer during the cooking process or when the frypot is filled with hot oil/shortening. If water comes in contact with oil/shortening heated to cooking temperature, it will cause spattering of the oil/shortening, which can result in severe burns to nearby personnel.

Any equipment works better and lasts longer when maintained properly and kept clean. Cooking equipment is no exception. Frymaster FPD65 Series gas fryers should be kept clean during the working day, and thoroughly cleaned at the end of each day. Below are recommendations for daily, weekly and periodic preventative maintenance.

6.1.1 Daily

 **WARNING**

Use a commercial grade cleaner formulated to effectively clean and sanitize food-contact surfaces. Read the directions and precautionary statements for use. Particular attention must be paid to the concentration of cleaner and the length of time the cleaner remains on the food-contact surfaces.

- A. Remove and wash all removable parts.
- B. Clean all exterior surfaces of the cabinet. Do not use cleaners, steel wool, or any other abrasive material on stainless steel.
- C. Filter the cooking oil and replace if necessary. The oil should be filtered more frequently when under heavy use.
- D. Clean filter pan, as well as, crumb tray as discussed on page 5-9.

6.1.2 Weekly

- A. Completely drain the oil from the fryer into a metal stockpot of sufficient size to safely hold the entire contents of the frypot for disposal. Do not use a glass or plastic container.
- B. Clean the frypot by following boil-out procedures in Chapter 4.2.

 **WARNING**

Never allow water to boil down and expose the heating tubes. Frypot damage will result.

FRYMASTER FPD65 SERIES GAS FRYERS

CHAPTER 6: PREVENTATIVE MAINTENANCE

6.1.3 Periodic/ Annual

The fryer should be inspected and adjusted periodically by qualified service personnel as part of a regular kitchen maintenance program.

Frymaster/Dean recommends that the fryer be inspected at least annually by a Factory Authorized Service Technician as follows:

- Inspect fryer cabinet inside and out, front and rear, for excessive oil build-up and/or oil migration. Verify that burners and associated components (i.e. gas valves, pilot assemblies, ignitors, etc.) are in good condition and functioning properly. Inspect all gas connections for leaks and ensure all connections are properly tightened.
- Verify that temperature and high-limit probes are properly connected, tightened and functioning properly.
- Verify all component box components (i.e. computer/controller, relays, transformers, interface boards, etc.) are in good condition and free from oil migration build-up and other debris. Inspect component box wiring and ensure all connections are tight and all wiring is in good condition. Ensure all safety features (i.e. drain safety switches, reset switches, etc.) are present and functioning properly.
- Verify that frypot is in good condition and free of leaks. Verify that frypot tube diffusers are present and in good condition (i.e. no visible deterioration or damage).
- Verify that all wiring and connections are tight and in good condition.

Built-in Filtration:

- Inspect all oil-return and drain lines for leaks and verify that all connections are tight.
- Inspect the filter pan for leaks and cleanliness. If there is a large accumulation of crumbs in the crumb basket, advise the owner/operator that the crumb basket should be emptied into a fireproof container and cleaned daily.
- Verify that all O-rings and seals (including those on quick-disconnect fittings) are present and in good condition. Replace O-rings and seals if worn or damaged.

FRYMASTER FPD65 SERIES GAS FRYERS
CHAPTER 6: PREVENTATIVE MAINTENANCE

6.1.3 Periodic/ Annual (cont.)

- Check filtration system integrity as follows:
 - With the filter pan empty, place each oil return handle, one at a time, in the "ON" position. Verify that the pump activates and that bubbles appear in the cooking oil/shortening of the associated frypot.
 - Close all oil return valves (i.e., place all oil return handles in the "OFF" position). Verify proper functioning of each oil return valve by activating the filter pump using the lever on one of the oil return handle microswitches. No air bubbles should be visible in any frypot.
 - Verify that the filter pan is properly prepared for filtering, then drain a frypot of oil heated to 350°F (177°C) into the filter pan and close the frypot drain valve. Place the oil return handle in the "ON" position. Allow all cooking oil/shortening to return to the frypot (indicated by bubbles in the cooking oil/shortening). Return the oil return handle to the "OFF" position. The frypot should refill in no more than 2 minutes and 30 seconds.

To ensure good fryer health and a safe environment, the fryer should be checked and adjusted periodically by qualified service personnel as part of a regular kitchen maintenance program.

6.1.4 Stainless Steel Care

 **DANGER**
DO NOT let water splash into the tank of hot oil. It will splatter and can cause severe burns.

All stainless steel fryer cabinet parts should be wiped regularly with hot, soapy water during the day, and with a liquid cleanser designed for stainless steel at the end of each day.

- A. Do not use steel wool, abrasive cloths, cleansers or powders.
- B. Do not use a metal knife, spatula or any other metal tool to scrape stainless steel! Scratches are almost impossible to remove.
- C. If it is necessary to scrape the stainless steel to remove any encrusted materials, soak the area first to soften the deposit, then use a wood or nylon scraper only.

FRYMASTER FPD65 SERIES GAS FRYERS

CHAPTER 7: TROUBLESHOOTING

7.1 General

⚠ DANGER

Hot cooking oil/shortening will cause severe burns. Never attempt to move this appliance when filled with hot cooking oil/shortening or to transfer hot cooking oil/shortening from one container to another.

⚠ DANGER

This equipment should be unplugged when servicing, except when electrical circuit tests are required. Use extreme care when performing such tests.

This appliance may have more than one electrical power supply connection point. Disconnect all power cords before servicing.

Inspection, testing and repair of electrical components should be performed by an authorized service agent only.

The problems and possible solutions covered are those most commonly encountered. To troubleshoot, perform the test set-up at the beginning of each condition. Follow each step in sequence.

7.2 Pilot Burner Malfunction

- A. Pilot will not ignite; no evidence of gas at pilot burner.
 - 1. Check that gas valve is open and gas is present at the gas valve.
 - 2. Check pilot burner orifice for dirt or lint.
 - 3. Authorized Service Agent Only: Remove pilot burner gas-supply line and check for contamination; blow out if necessary, then reinstall.

- B. Pilot burner ignites but will not remain lit when gas valve manual knob is released.
 - 1. Check that thermopile lead is properly connected at the terminal block on the gas valve.
 - 2. Authorized Service Agent Only: Pilot flame may be too high or too low. Adjust pilot flame adjustment screw so that pilot flame extends about 3/4-inch (19-mm) above the top of the pilot burner.

FRYMASTER FPD65 SERIES GAS FRYERS
CHAPTER 7: TROUBLESHOOTING

7.2 Pilot Burner Malfunction (cont.)

3. Check all connections for cleanliness and security.
- C. Pilot flame of proper size, but is unstable. Flame wavers and does not envelop the thermopile completely at all times.
1. Check for drafts that might be caused by air conditioning equipment or make-up air apparatus. Turn air-moving equipment off and recheck the pilot.

7.3 Main Burner Malfunctions

- A. Main burner will not come "ON"; gas not detected at main burner.
1. Check that the gas valve is open.
 2. Check that the pilot is ignited and is operating properly.
 3. Authorized Service Agent Only: Check the high-limit switch for continuity.
 4. Authorized Service Agent Only: Check the combination gas valve and replace if defective.
- B. Main burner flames are small and appear lazy; shortening does not come up to temperature quickly.
1. Authorized Service Agent Only: Check gas pressure at the pressure tap of the gas valve. Use dial type or standard water-type U-gauge manometer. With burner in operation, the pressure should be 4" W.C. (10 mbar) for natural gas, and 11" W.C. (27.5 mbar) for propane. If not, remove the pressure regulator adjustment cover. Use screwdriver to turn the adjusting screw for proper pressure. Replace cover, re-check pressure and re-install pressure tap plug.
- C. Signs of excessive temperature; shortening scorches and quickly becomes discolored.
1. Check operating thermostat. May be out of adjustment or calibration. Recalibrate if necessary.
 2. Check gas pressure as outlined above.
 3. Shortening used is of inferior quality and/or shortening has been used too long. Replace shortening.
 4. Ensure frypot is clean when refilling with new shortening.

FRYMASTER FPD65 SERIES GAS FRYERS
CHAPTER 7: TROUBLESHOOTING

7.3 Main Burner Malfunctions (cont.)

- D. Fryer will not reach the temperature setting and/or runs erratically.
 - 1. Incorrect location of sensor probe or defective temperature sensor.
 - 2. Loose wiring/wire connection
- E. Fryer shortening temperature cannot be controlled; fryer runs at high-limit temperature.
 - 1. Defective temperature probe; Call Authorized Service Agent.

FRYMASTER FPD65 SERIES GAS FRYERS

CHAPTER 7: TROUBLESHOOTING

7.4 Wiring Diagram, Main

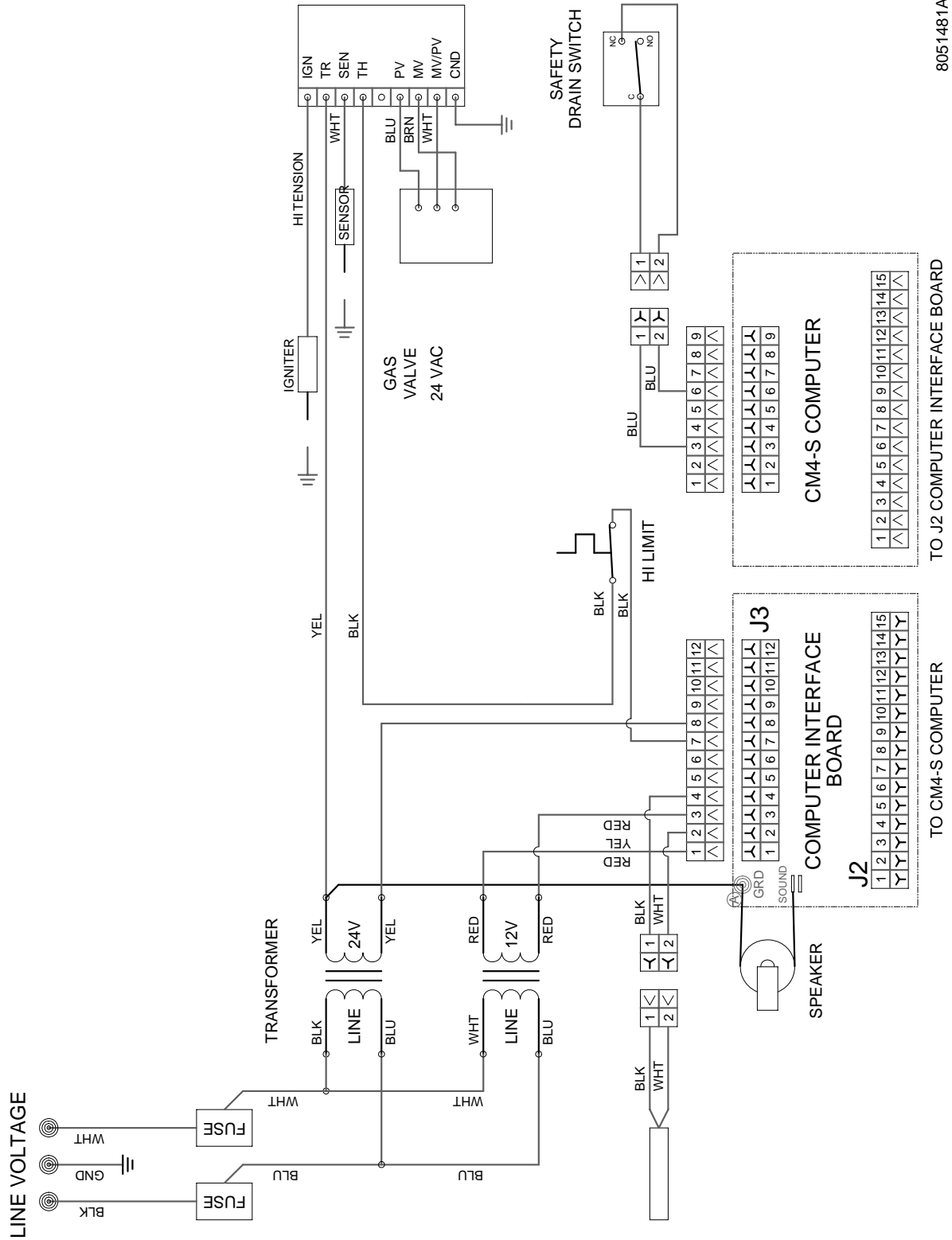

8051481A

FRYMASTER FPD65 SERIES GAS FRYERS CHAPTER 7: TROUBLESHOOTING

7.5 Wiring Diagram, Filter

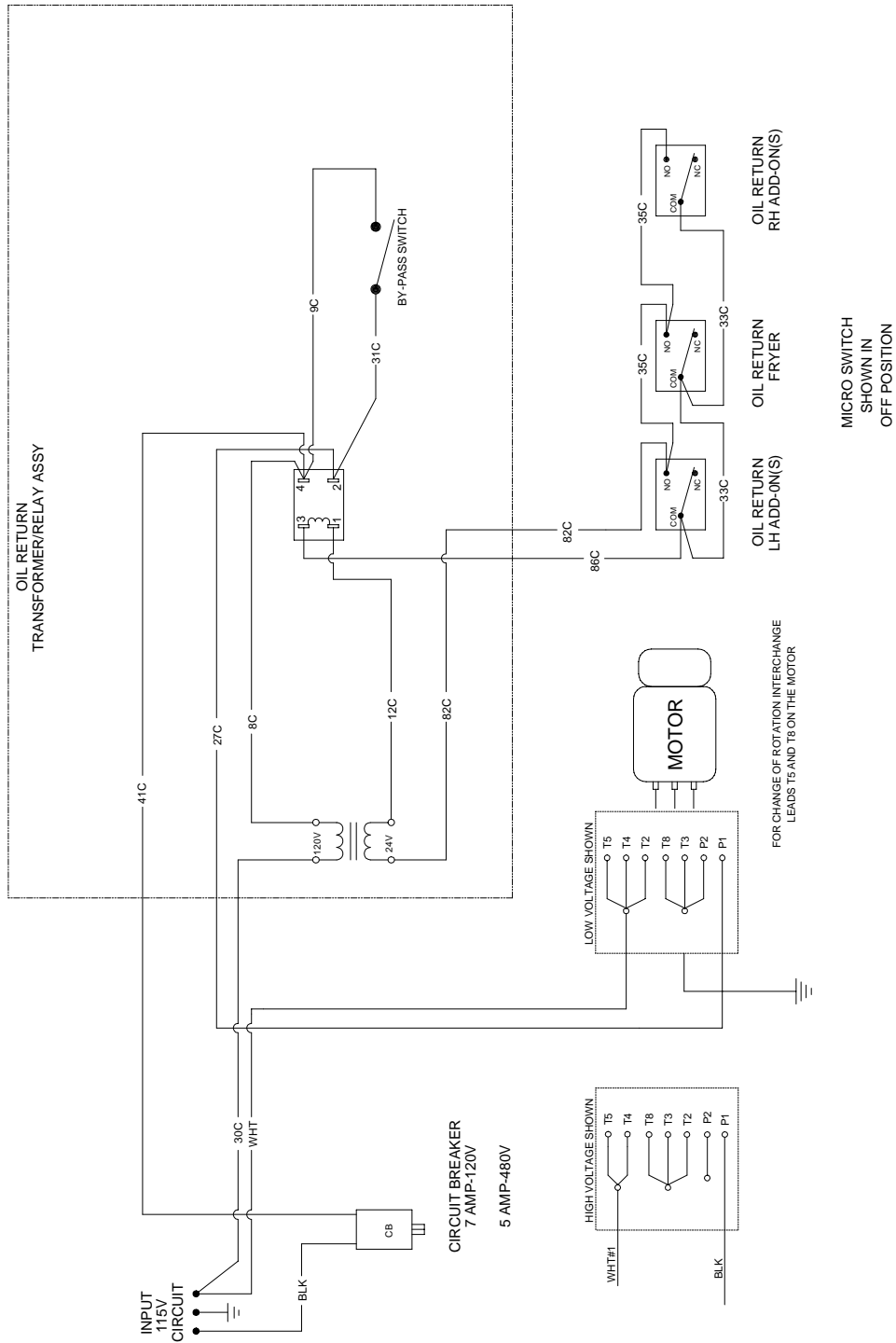

8051428A

FRYMASTER FPD65 SERIES GAS FRYERS

CHAPTER 8: PARTS LIST

8.1 Cabinetry and Related Components

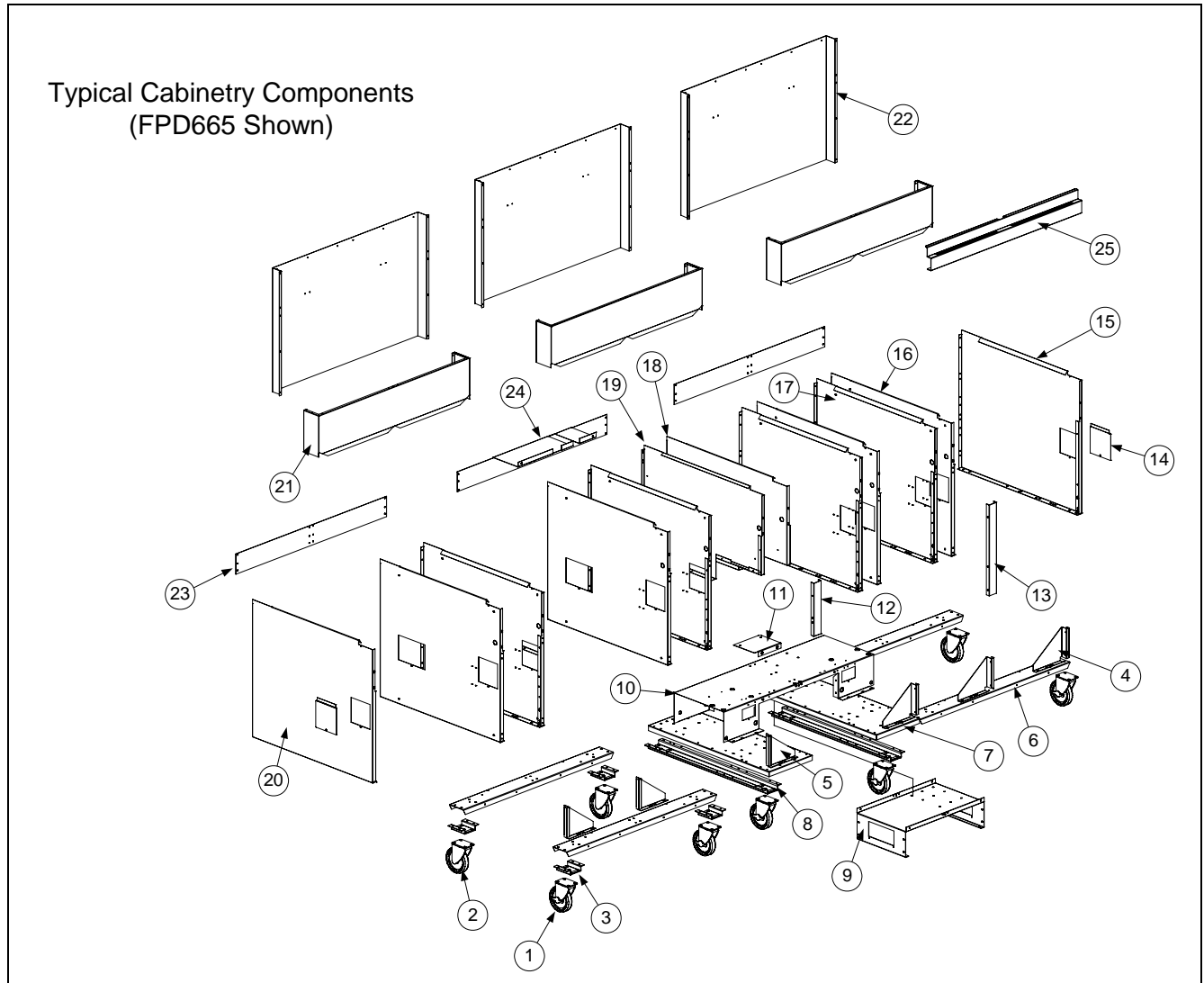

**FRYMASTER FPD65 SERIES GAS FRYERS
CHAPTER 8: PARTS LIST**

8.1 Cabinetry and Related Components (cont.)

ITEM	PART #	COMPONENT
1	810-0357	Caster, 5" Swivel – With Brake
2	810-0356	Caster, 5" Swivel – Without Brake
3	823-3248	Support, Caster- Channel Base
4	202-1182	Gusset, Side Panel- Left
5	201-1182	Gusset, Side Panel- Right
6	200-1463	Channel, Base- Front & Rear- 2-Battery (FPD565 & FPD665)
*	200-2493	Channel, Base- Front & Rear- 1-Battery (FPD565 Only)
7	200-1198	Channel, Base- UFF Filter
8	823-3352	Support, Caster- UFF Base
9	200-1493	Frame, Base Lower Plate- UFF
10	200-1611	Base, Upper- UFF
11	200-4241	Plate, Motor Support- Offset
12	200-2308	Post, Door- UFF Cabinet
13	200-1393	Channel, Lower Joiner
14	200-1471	Duct, Door Access
15	202-1299	Panel, Side- Painted- Right
16	201-4775	Panel, Inner- Left
17	202-4775	Panel, Inner- Right
18	201-4237	Panel, Inner UFF- Left
19	202-4237	Panel, Inner UFF- Right
20	201-1299	Panel, Side- Painted- Left
21	823-3826	Fluecap
22	200-3696	Back, Upper Structural (FPD665)
*	200-3694	Back, Upper Structural (FPD565)
*	200-1376	Bracket, Restraining
23	200-1425	Back, Lower Structural- Right & Left Cabinet
24	200-4238	Back, Lower Structural- Middle UFF Cabinet
25	210-3700	Hanger, Basket- 2-Battery
* Not Illustrated		

**FRYMASTER FPD65 SERIES GAS FRYERS
CHAPTER 8: PARTS LIST**

8.2 Doors, Topcaps and Related Components

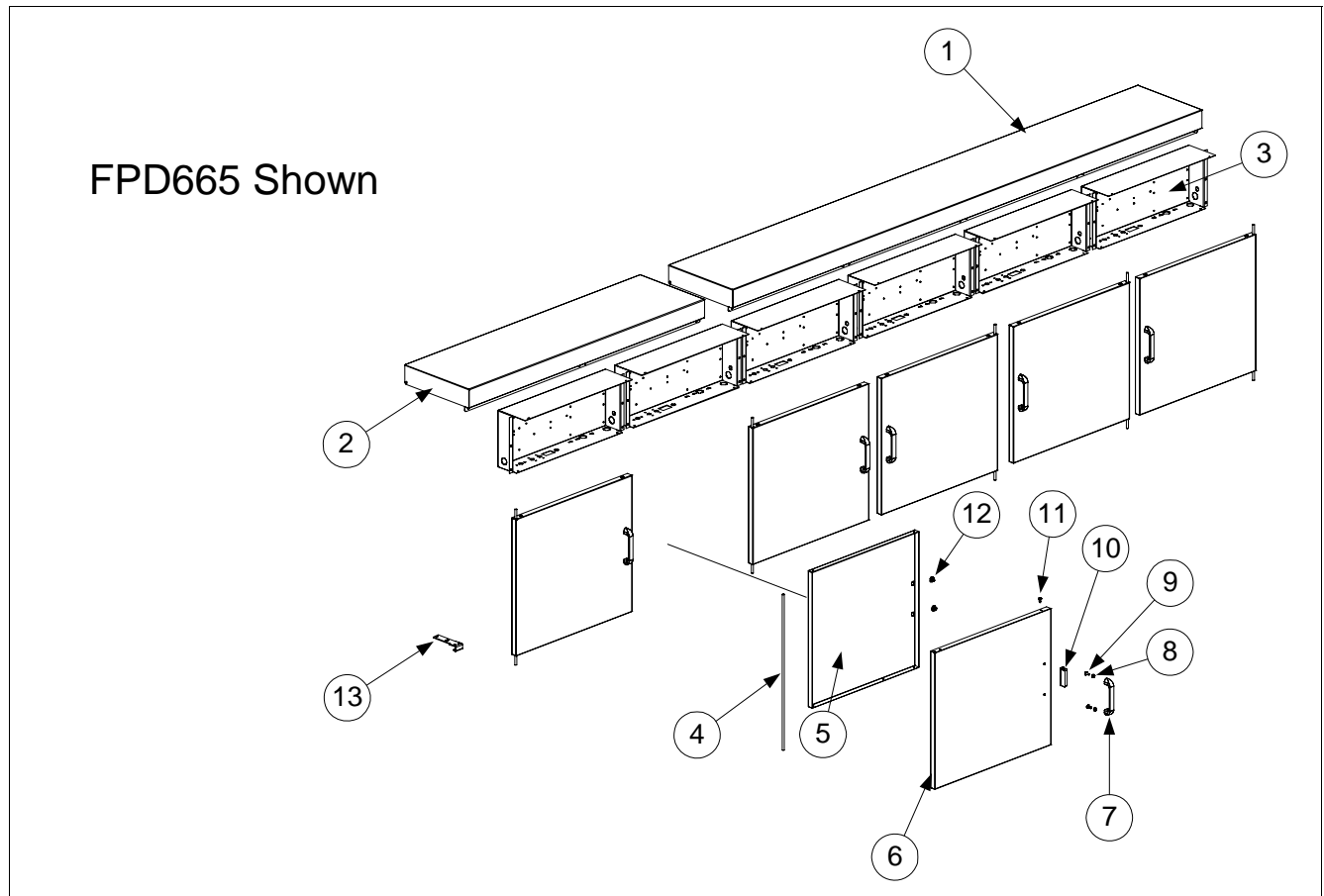

ITEM	PART #	COMPONENT
1	824-1183	Topcap, 4-Battery
*	824-1184	Topcap, 3-Battery
2	824-1185	Topcap, 2-Battery
3	824-0951	Wireway, Control Panel (Component Box: See Section 8.4 For Electronic Components)
4	200-1301	Pin, Door
5	200-1185	Panel, Door- Inner
6	210-1424	Panel, Door- Outer
7	810-2105	Handle, Door- Chrome
8	809-0918	Screw, #10-24 x 1/2" (Use With 810-2105)
9	809-0191	Washer, 1/4" Lock (Use With 810-2105)
10	810-0066	Magnet, Door Catch- All Doors Except Filter
*	810-1105	Magnet, Door Catch- Filter Cabinet Doors
*	200-3663	Plate, Door Magnet (Use Where Magnet Contacts Stainless Steel)
11	809-0266	Screw, #10 x 1/2"
12	810-0179	Plug, Access (Handle Screws)
13	200-1675	Hinge, Lower Bracket- Door
*	809-0413	Spacer, Nylon- Lower Hinge/Door Pin

* Not Illustrated

FRYMASTER FPD65 SERIES GAS FRYERS
CHAPTER 8: PARTS LIST

8.3 Frypots, Burners and Related Components

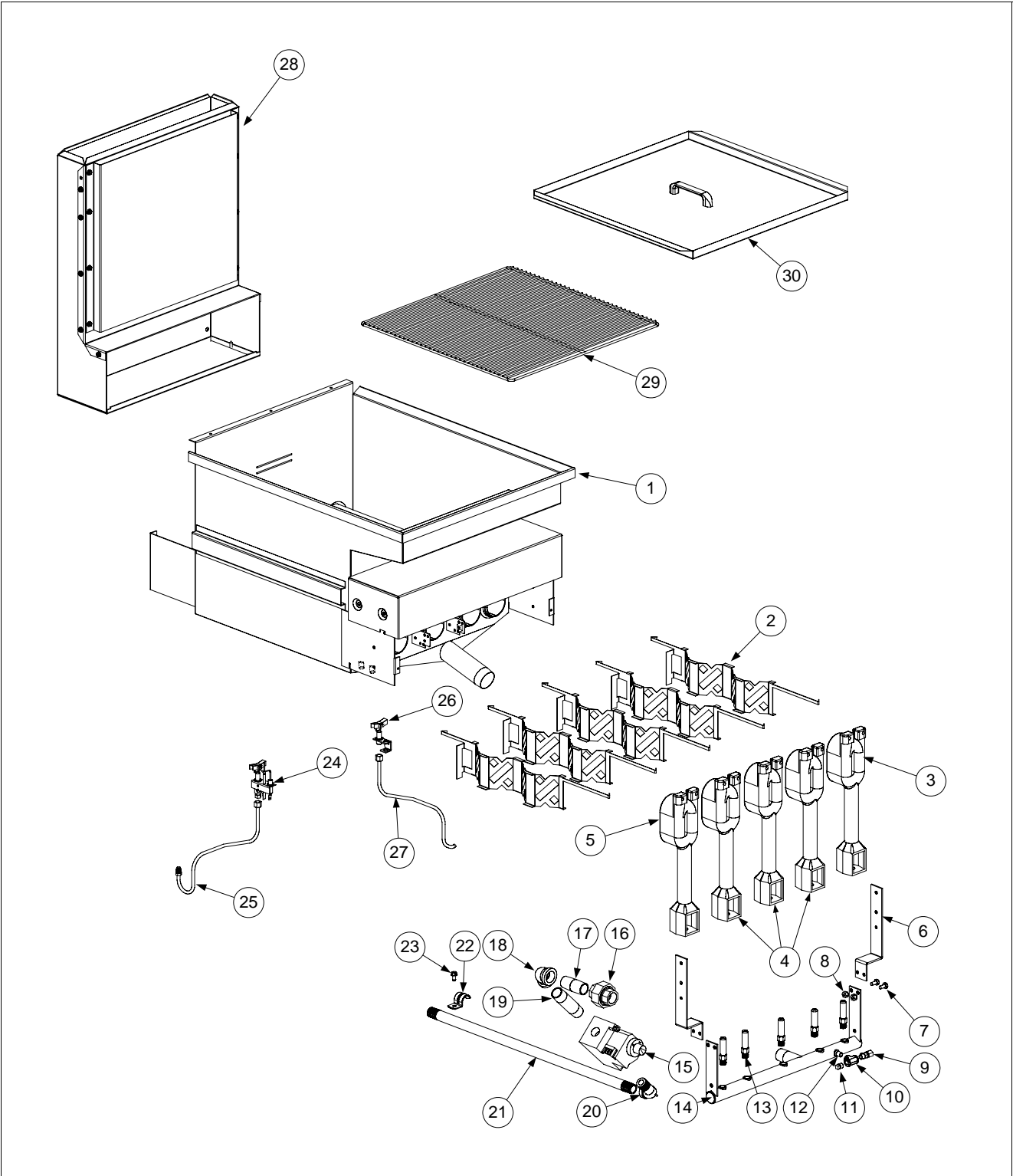

**FRYMASTER FPD65 SERIES GAS FRYERS
CHAPTER 8: PARTS LIST**

8.3 Frypots, Burners and Related Components (cont.)

ITEM	PART #	COMPONENT
1	823-3948	Frypot- S/S- 65 Series
2	210-5170	Diffuser, Burner Tube
3	810-2150	Burner, Right
4	810-2149	Burner, Center
5	810-2151	Burner, Left
*	200-2738	Bracket, Burner Mounting
*	200-2746	Shield, Burner Heat
6	200-1615	Bracket, Manifold Mounting
7	809-0822	Bolt, ¼-20 x ½" Hex Head
8	809-0823	Nut, Nylock- ¼-20
9	810-2138	Valve, Trailing Pilot
10	813-0642	Tee, 1/8" NPT
11	813-0705	Plug, Brass- 1/8" Square Head
12	813-0643	Nipple, 1/8" NPT x Close BM
13	810-2050	Orifice, Natural- #44 (2.18 mm)
*	810-2324	Orifice, LP- #53 (1.40 mm)
14	823-3617	Manifold, Gas
15	807-3628	Valve, Gas- LP-24V, Honeywell
*	807-3552	Valve, Gas- Natural-24V, Honeywell
16	813-0174	Union- ¾" NPT BM
17	813-0635	Nipple, ¾ NPT x 2-½" BM
18	813-0066	Elbow- ¾" NPT 90° BM
19	813-0743	Nipple, ¾ NPT x 3-½" BM
20	813-0165	Elbow, Street- ½" NPT 90° BM
21	813-0670	Nipple, ½ NPT x 19" BM (<u>Measure To Confirm Length</u>)
*	813-0585	Nipple, ½ NPT x 20-½" BM (<u>Measure To Confirm Length</u>)
*	813-0737	Nipple, ½ NPT x 21" BM (<u>Measure To Confirm Length</u>)
22	810-2043	Clamp, Pipe- ½"
23	809-0805	Bolt, Pipe Clamp- ¼-20 x ½" Hex
*	200-1450	Bracket, Gas-Supply Clamp Support (UFF-Equipped Systems)
24	807-1553	Burner, Pilot- LP- Electronic Ignition
*	807-1311	Burner, Pilot- Natural- Electronic Ignition
*	807-1310	Sensor, Flame
25	810-0703	Gas Line, Main Pilot Supply- ¼ x 17-½"
*	810-0705	Gas Line, Main Pilot Supply- ¼ x 23"
26	810-2155	Burner, Trailing Pilot- LP
*	810-2032	Burner, Trailing Pilot- Natural
27	812-1544	Gas Line, Trailing Pilot Supply- ¼ x 12" (Not For Main Pilot)
28	106-2634SP	Flue Assembly, Complete
*	200-4086	Shield, Flue Heat
*	200-4087	Front, Flue Box
*	200-4088	Rear, Flue Box
*	200-3649	Deflector, Flue
29	810-2524	Grid, Frypot- 65 Series
30	106-2897SP	Cover, Frypot- 65 Series

* Not Illustrated

FRYMASTER FPD65 SERIES GAS FRYERS
CHAPTER 8: PARTS LIST

8.4 Component Box Components

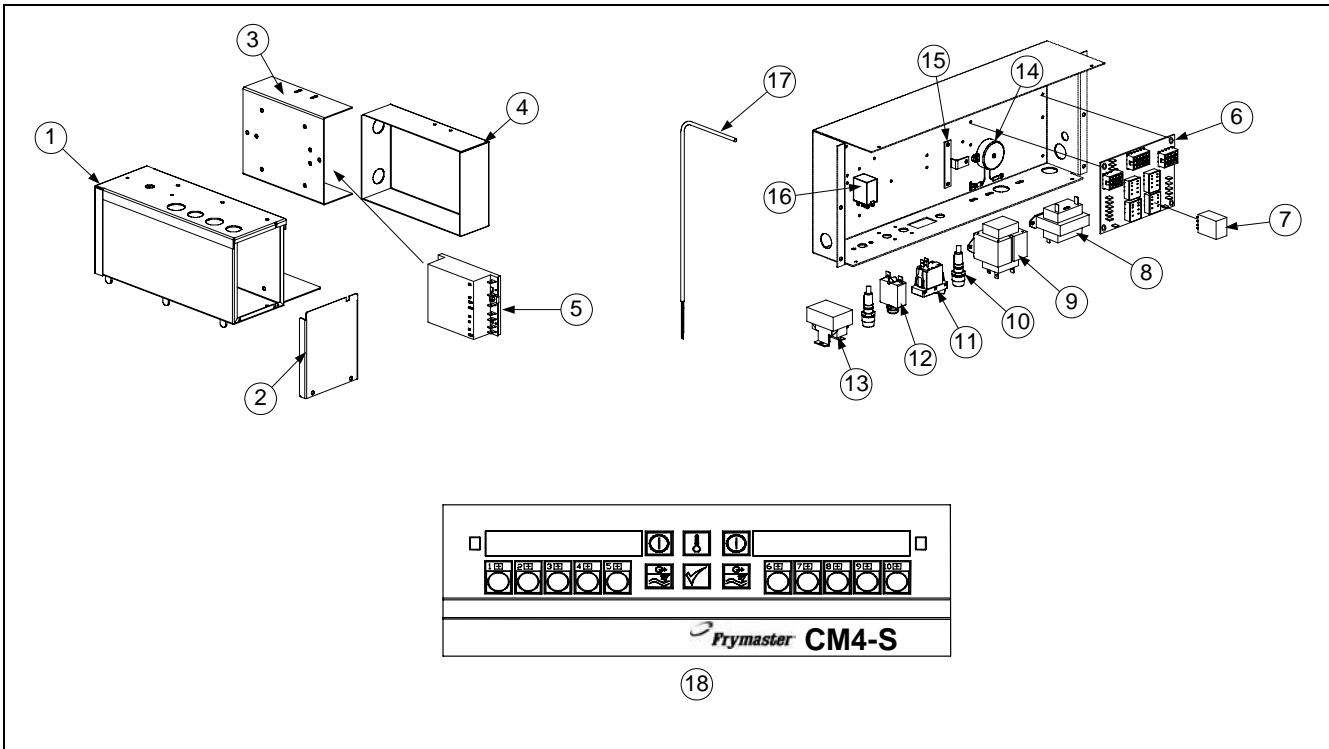

ITEM	PART #	COMPONENT
1	823-3242	Control Box (Inside Non-Filter Fryer Cabinets)
2	210-1364	Plate, Face (For Item #1)
3	200-1322	Bracket, Spark Module
4	200-1326	Cover, Spark Module
5	807-3563	Module, Ignition (Spark)
*	807-1315	Cable, Ignition Module
6	826-2434	Interface Board, Electronic Ignition
	826-2425	Interface Board, Standing Pilot
7	807-0833	Relay, 12VDC 5A 1PDT (Latching)
8	807-0855	Transformer, 120VAC 50/60 Hz -12V 20VA
9	807-0800	Transformer, 120VAC 50/60 Hz -24V 50VA
10	807-1321	Fuse Holder, Buss
*	807-3750	Fuse, 5A
11	807-3580	Switch, Rocker- Manual Filter Power
12	807-3577	Breaker, Circuit- 7-Amp (115VAC Circuits)
*	807-3538	Breaker, Circuit- 5-Amp (230VAC Circuits)
13	807-3680	High-Limit Thermostat- Manual Reset 450° F (Non-CE Only)
14	806-7179	Device, Sound
15	200-2052	Bracket, Sound Device
16	807-3611	Relay, Filter- 24VAC Coil 24A
17	106-1541SP	Probe, Temperature- Computer
18	806-8305	Computer, CM4-S- With Bezel Generic (Segmented Programming)
	106-3028	Computer, CM4-S- With Bezel Church's Only (Segmented. Prog.)
*	823-3433	Bezel, Computer

* Not Illustrated

**FRYMASTER FPD65 SERIES GAS FRYERS
CHAPTER 8: PARTS LIST**

8.5 Filter Pan and Related Components

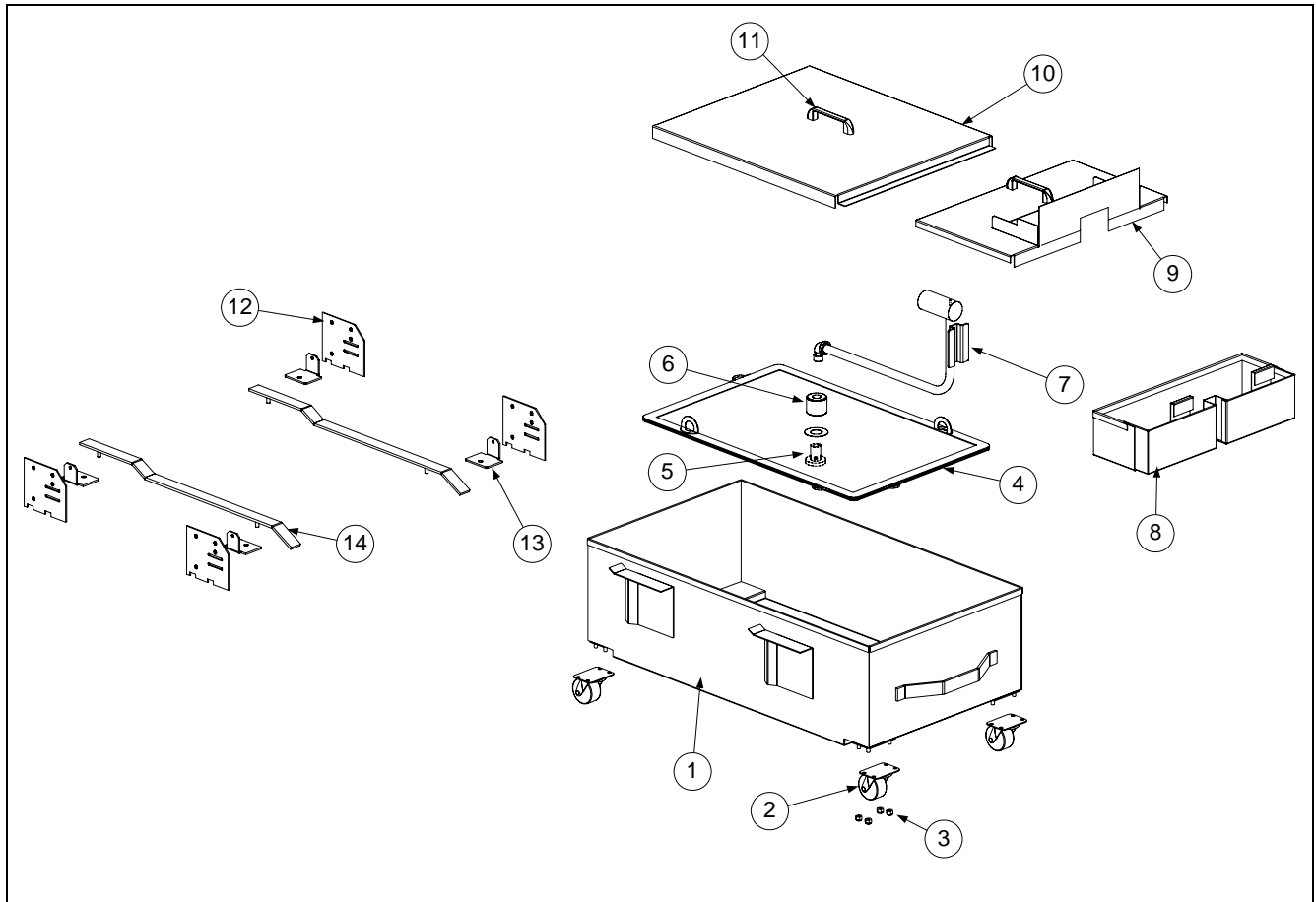

ITEM	PART #	COMPONENT
1	823-4109	Pan, Filter
2	810-2141	Caster, Filter Pan- 2"
3	809-0823	Nut, Nylock- ¼-20
4	810-2350	Leaf, Filter- 14-½ x 22-½"
5	810-2583	Fitting, Bottom- Filter Leaf
6	810-2582	Fitting, Top- Filter Leaf
*	803-0002	Powder, Filter- Box (Filter Magic- 100 1-Cup Applications)
7	823-4112	Tube, Suction
*	813-0679	Plug, Suction- 1/8" S/S Square Head
8	823-3872	Screen, Crumb
9	823-3178	Cover, Filter Pan- Front
10	210-1592	Cover, Filter Pan- Rear
11	810-2105	Handle, Pan Cover- Chrome
*	809-0918	Screw, #10-24 x ½" (Use With 810-2105)
*	809-0191	Washer, ¼" Lock (Use With 810-2105)
12	200-2713	Bracket, Slide Rail
13	210-1180	Insert, Slide Rail Bracket
14	823-3347	Rail, Slide

* Not Illustrated

FRYMASTER FPD65 SERIES GAS FRYERS
CHAPTER 8: PARTS LIST

8.6 Oil-Drain Components

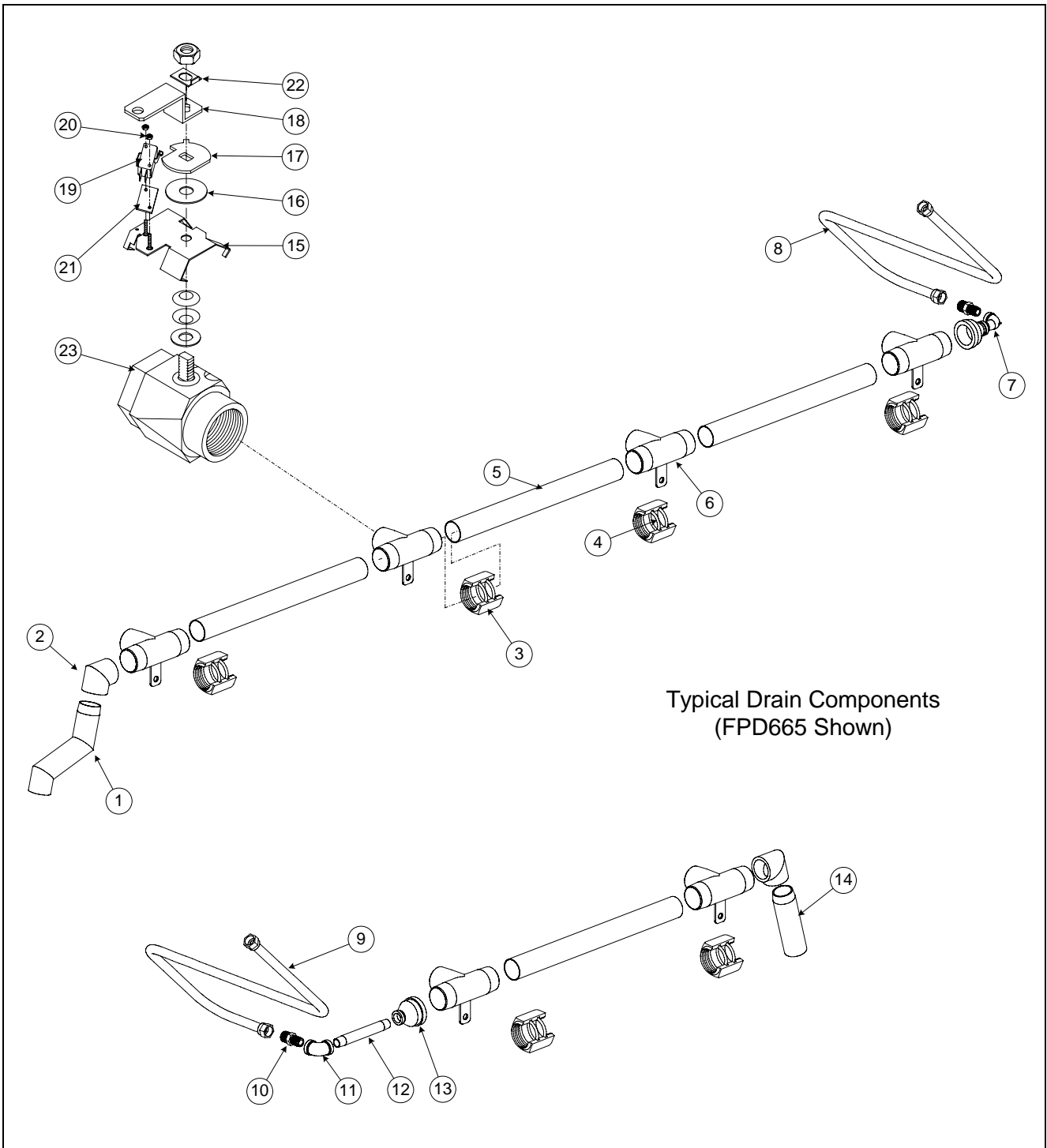

**FRYMASTER FPD65 SERIES GAS FRYERS
CHAPTER 8: PARTS LIST**

8.6 Oil-Drain Components (cont.)

ITEM	PART #	COMPONENT
1	823-4189	Pipe, Drain- Right- D665 (With Oil Disposal System)
*	823-3441	Pipe, Drain- Right- D565 (No Oil-Disposal System)
2	813-0829	Elbow, Drain Pipe- 75°
3	809-0884	Nut, Slip Joint- 1-½"
4	816-0544	O-ring (Slip-Joint Nut)
5	200-1840	Drain Manifold Tube
6	813-0749	Tee, 1-½" NPT With Handle
7	813-0165	Elbow, Street- ½ x ½" 90°
8	810-1069	Flex Line, 5/8" x 29-½" (Measure To Confirm Length)
9	810-1057	Flex Line, 5/8 x 13" (Measure To Confirm Length)
10	810-1668	Adapter, 5/8" O.D. x ½"- Male (Use With 810-1057 and 810-1069)
11	813-0062	Elbow, ½" NPT BM 90°
12	813-0096	Nipple, ½ x 6" NPT BM
13	813-0686	Bell Reducer, 1-½ x ½" NPT
14	813-0784	Drain Pipe, Left Side
Drain Valve Components		
15	106-1401	Bracket, Microswitch (Optional On Some Units)
16	200-1617	Washer, Drain Valve (Use Without Microswitch)
17	210-2029	Bracket, Activator- Microswitch
18	200-1940	Handle (Actuator), Drain Valve
*	823-3440	Handle, Push/Pull- Drain (With Cap)
*	809-0885	Washer, 3/8 x 1 x .083"
*	809-0843	Cotter Pin
*	816-0547	Cap, Vinyl-Red
19	807-2104	Microswitch (Optional On Some Units)
20	809-0842	Nut, Nylock- #4-40 (Microswitch To Bracket)
21	816-0220	Insulation, Microswitch
22	200-1257	Retainer, Nut
23	810-2127	Drain Valve, 1-½" Full Port (With Washers & Nut)

* Not Illustrated

**FRYMASTER FPD65 SERIES GAS FRYERS
CHAPTER 8: PARTS LIST**

8.7 Oil-Return Components

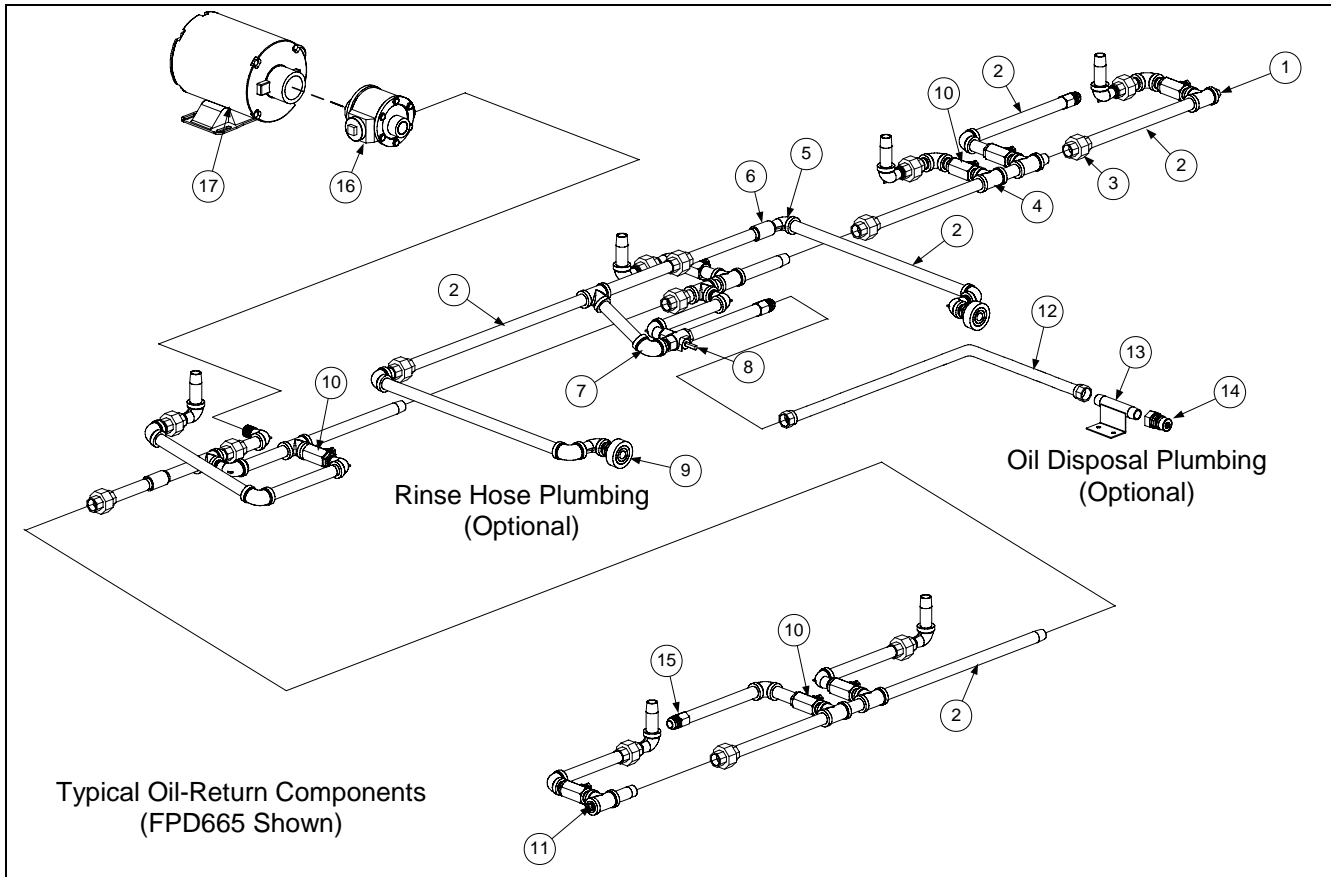

ITEM	PART #	COMPONENT
1	813-0156	Plug, Pipe- Hex Head Extruded
2		Nipple, Pipe (Measure To Confirm Length Prior To Replacing; Choose From Nipple Lengths Below)
	813-0022	Nipple, ½" x Close NPT BM
	813-0087	Nipple, ½ x 1-½" NPT BM
	813-0298	Nipple, ½ x 2" NPT BM
	813-0265	Nipple, ½ x 2-½" NPT BM
	813-0460	Nipple, ½ x 3" NPT BM
	813-0247	Nipple, ½ x 3-½" NPT BM
	813-0251	Nipple, ½ x 4-½" NPT BM
	813-0646	Nipple, ½ x 5" NPT BM
	813-0742	Nipple, ½ x 5-½" NPT BM
	813-0674	Nipple, ½ x 7-¼" NPT BM
	813-0672	Nipple, ½ x 8" NPT BM
	813-0673	Nipple, ½ x 8-½" NPT BM
	813-0698	Nipple, ½ x 10-½" NPT BM
	813-0515	Nipple, ½ x 12" NPT BM
	813-0418	Nipple, ½ x 17" NPT BM
	813-0670	Nipple, ½ x 19" NPT BM

* Not Illustrated

**FRYMASTER FPD65 SERIES GAS FRYERS
CHAPTER 8: PARTS LIST**

8.7 Oil-Return Components (cont.)

ITEM	PART #	COMPONENT
3	813-0173	Union, ½" NPT BM
4	813-0003	Tee, ½" NPT BM
5	813-0165	Elbow, Street ½" NPT BM 90°
6	813-0051	Coupling, ½" NPT BM
7	813-0062	Elbow, ½" NPT BM 90°
8	810-1003	Valve, Ball- Three-Way ½" 180°
*	823-4234	Handle, Wand/Disposal
*	210-4239	Bracket, Wand/Disposal Handle
*	816-0549	Cap, Handle- Blue (Cut Length To Fit)
9	106-1837SP	Disconnect Assembly, With Collar
10	810-0278	Valve, Ball- Oil-Return ½"
*	823-3187	Handle, Oil-Return Valve
*	816-0548	Cap, Oil-Return Handle- Yellow
*	823-4174	Handle Assembly (Actuator)- Oil-Return Valve
*	809-0885	Washer, Actuator- Ball Valve- 3/8 x 1 x 0.083"
11	813-0463	Plug, Counter-Sink Hex ½"
Oil Disposal Components		
12	810-1056	Flexline, Oil Disposal- 5/8 x 52-½"
13	823-3996	Nipple Assembly, Oil Disposal
14	810-0487	Disconnect, Male- Oil Disposal
15	810-1669	Adapter, Female- 5/8 x ½"
*	810-0278	Handle, Oil-Return Flush Valve
*	816-0549	Cap, Flush Valve Handle- Blue
16	810-2098	Pump, Filter- 8GPM
17	810-2100	Motor, Filter Pump- 120/230VAC 1/3 HP

* Not Illustrated

8.8 Suction Tube, Oil-Return Components

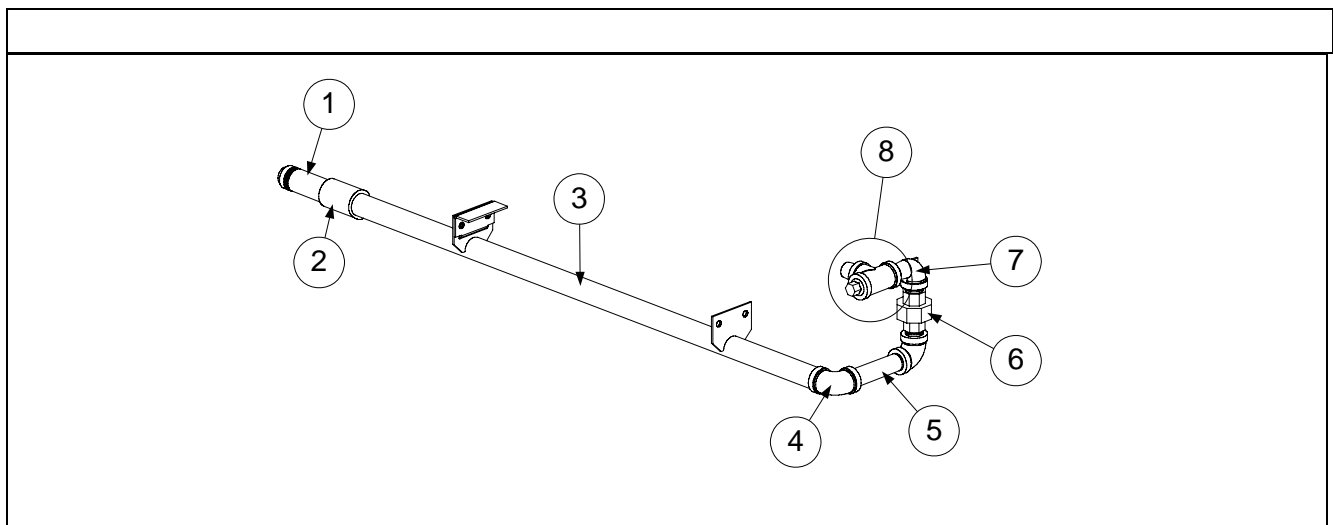

**FRYMASTER FPD65 SERIES GAS FRYERS
CHAPTER 8: PARTS LIST**

8.8 Suction Tube, Oil-Return Components (cont.)

ITEM	PART #	COMPONENT
1	810-0697	Disconnect, Male- Suction Tube
*	826-1392	O-ring, Suction Tube Connection (Qty: 5)
2	813-0608	Coupling, Full- ½" NPT BM
3	823-3188	Suction Manifold Assembly
4	813-0062	Elbow, ½" x 90° NPT BM
5	813-0093	Nipple, ½ NPT x 4" NPT BM
6	813-0173	Union, ½" NPT BM
7	813-0165	Elbow, Street- ½" x 90° NPT BM
8		Oil Suction Start Fitting
	813-0022	Nipple- ½" NPT x Close BM
	813-0156	Plug, ½" NPT BM Hex Head
	813-0003	Tee, ½" NPT BM
* Not Illustrated		

THIS PAGE INTENTIONALLY LEFT BLANK



Enodis[®]
One Company, Countless Solutions

Frymaster, 8700 Line Avenue, Shreveport, Louisiana 71106

TEL 1-318-865-1711

FAX (Parts) 1-318-688-2200

FAX (Tech Support) 1-318-219-7135

PRINTED IN THE UNITED STATES

SERVICE HOTLINE
1-800-551-8633

819-6039
SEPT 2008