



PRO SERIES
ELECTRIC FRYERS
Service & Parts Manual



Frymaster, a member of the Commercial Food Equipment Service Association, recommends using CFESA Certified Technicians.

24-Hour Service Hotline 1-800-551-8633

MAR 2008
* 8195990 *

NOTICE

IF, DURING THE WARRANTY PERIOD, THE CUSTOMER USES A PART FOR THIS ENODIS EQUIPMENT OTHER THAN AN **UNMODIFIED** NEW OR RECYCLED PART PURCHASED DIRECTLY FROM FRYMASTER/DEAN, OR ANY OF ITS AUTHORIZED SERVICE CENTERS, AND/OR THE PART BEING USED IS MODIFIED FROM ITS ORIGINAL CONFIGURATION, THIS WARRANTY WILL BE VOID. FURTHER, FRYMASTER AND DEAN AND ITS AFFILIATES WILL NOT BE LIABLE FOR ANY CLAIMS, DAMAGES OR EXPENSES INCURRED BY THE CUSTOMER WHICH ARISE DIRECTLY OR INDIRECTLY, IN WHOLE OR IN PART, DUE TO THE INSTALLATION OF ANY MODIFIED PART AND/OR PART RECEIVED FROM AN UNAUTHORIZED SERVICE CENTER.

⚠ DANGER

Copper wire suitable for at least 167°F (75°C) must be used for power connections.

⚠ DANGER

The electrical power supply for this appliance must be the same as indicated on the rating and serial number plate located on the inside of the fryer door.

⚠ DANGER

This appliance must be connected to the voltage and phase as specified on the rating and serial number plate located on the inside of the fryer door.

⚠ DANGER

All wiring connections for this appliance must be made in accordance with the wiring diagrams furnished with the equipment. Wiring diagrams are located on the inside of the fryer door.

⚠ DANGER

Do not store or use gasoline or other flammable vapors and liquids in the vicinity of this or any other appliance.

⚠ WARNING

Do not attach accessories to this fryer unless fryer is secured from tipping. Personal injury may result.

⚠ WARNING

Frymaster fryers equipped with legs are for permanent installations. Fryers fitted with legs must be lifted during movement to avoid damage and possible bodily injury. For a moveable or portable installation, Frymaster optional equipment casters must be used. Questions? Call 1-800-551-8633

⚠ WARNING

Do not use water jets to clean this equipment.

⚠ DANGER

All wiring connections for this appliance must be made in accordance with the wiring diagrams furnished with the equipment. Wiring diagrams are located on the inside of the fryer door.

⚠ WARNING

This equipment is intended for indoor use only. Do not install or operate this equipment in outdoor areas.

ELECTRICAL POWER SPECIFICATIONS

kW	VOLTAGE	PHASE	WIRE SERVICE	MINIMUM SIZE		AMPS PER LEG		
				AWG	mm ²	L1	L2	L3
14	208	3	3	6	16	39	39	39
14	240	3	3	6	16	34	34	34
14	480	3	3	8	10	17	17	17
14	220/380	3	4	6	16	21	21	21
14	240/415	3	4	6	16	20	20	21
14	230/400	3	4	6	16	21	21	21
ALL EPRI 14kW (SOLID STATE)	208	3	3	6	16	39	39	39
	240	3	3	6	16	34	34	34
	220/380	3	4	6	16	21	21	21
	240/415	3	4	6	16	20	20	20
17	208	3	3	6	16	48	48	48
17	240	3	3	6	16	41	41	41
17	480	3	3	6	16	21	21	21
17	220/380	3	4	6	16	26	26	26
17	240/415	3	4	6	16	24	24	24
17	230/400	3	4	6	16	25	25	25
ALL EPRI 17kW (SOLID STATE)	208	3	3	6	16	48	48	48
	240	3	3	6	16	41	41	41
	220/380	3	4	6	16	26	26	26
	240/415	3	4	6	16	24	24	24
22	208	3	3	4	25	61	61	61
22	240	3	3	4	25	53	53	53
22	480	3	3	6	16	27	27	27
22	220/380	3	4	6	16	34	34	34
22	240/415	3	4	6	16	31	31	31
22	230/400	3	4	6	16	32	32	32

TABLE OF CONTENTS

	Page
CAUTIONARY STATEMENTS	i
ELECTRICAL POWER SPECIFICATIONS	ii
CHAPTER 1 – SERVICE PROCEDURES	1-1
1.1 General.....	1-1
1.2 Replacing a Controller.....	1-1
1.3 Replacing Component Box Components.....	1-2
1.4 Replacing a Temperature Probe or High-Limit Thermostat.....	1-3
1.5 Replacing a Heating Element.....	1-5
1.6 Replacing Contactor Box Components.....	1-6
1.7 Replacing a Frypot.....	1-7
1.8 Built-in Filtration System Service Procedures.....	1-8
1.9 Basket Lift Service Procedures.....	1-12
1.10 Interface Board Diagnostic Charts.....	1-15
1.11 Wiring Diagrams.....	1-16
CHAPTER 2 – PARTS LIST	2-1
2.1 Accessories.....	2-1
2.2 Basket Lift Assembly and Associated Parts.....	2-2
2.3 Cabinetry.....	2-4
2.4 Drain System Components.....	2-8
2.5 Electronics and Wiring Components.....	2-16
2.6 Filtration System Components.....	2-28
2.7 Frypot Assemblies and Associated Parts.....	2-31
2.8 Oil Return System Components.....	2-33

PRO SERIES ELECTRIC FRYERS

CHAPTER 1: SERVICE PROCEDURES

1.1 General

Before performing any maintenance on your Frymaster fryer, disconnect the fryer from the electrical power supply.

When electrical wires are disconnected, it is recommended that they be marked in such a way as to facilitate re-assembly.

1.2 Replacing a Controller

1. Before removing controllers from **Euro-look models** (round top-cap and drains), slide the metal bezel up to release the bottom tabs; then, remove it.
2. Remove the two screws from the upper corners of the control panel. The control panel is hinged at the bottom and swings open from the top.

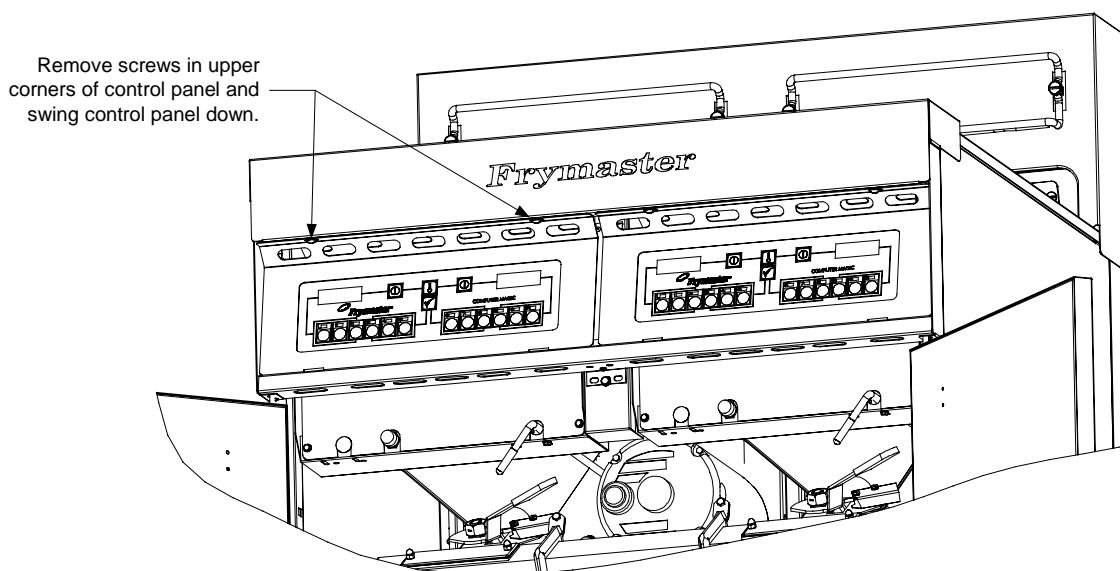

3. Unplug the wiring harness from the connector on the back of the controller and disconnect the grounding wire from terminal adjacent to the connector. Remove the control panel assembly by lifting it from the hinged slots in the control panel frame.

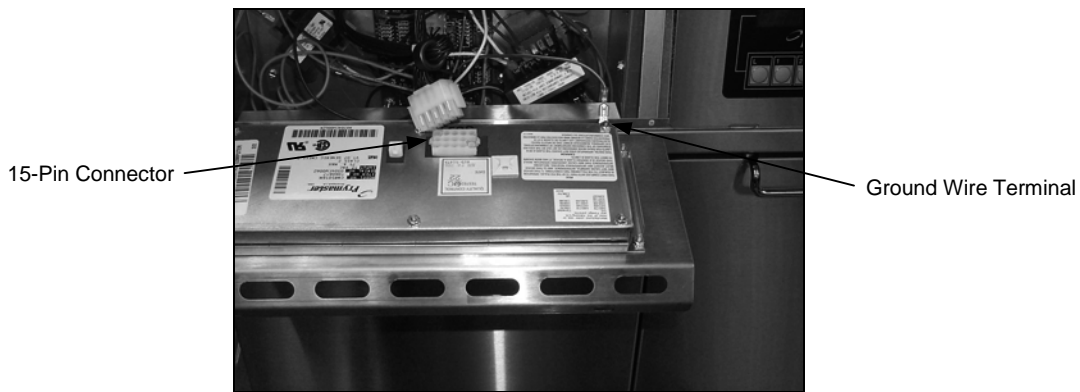

4. Remove the controller from the control panel assembly and install the replacement controller. Reinstall the control panel assembly by reversing steps 1 and 2.

1.3 Replacing Component Box Components

1. Remove the two screws from the upper corners of the control panel and allow the control panel to swing down (see steps 1 and 2 of section 1.2 on preceding page).
2. Unplug the wiring harness from the 15-pin connector on the interface board and disconnect the grounding wire from terminal adjacent to the 15-pin connector on the back of the controller. Remove the control panel assembly by lifting it from the hinge slots in the control panel frame.
3. Disconnect the wiring from the component to be replaced, being sure to make a note of where each wire was connected.

NOTE: If replacing the interface board, connectors J1 and J2 must also be disconnected from the 12-pin connectors on the rear of the component box, directly behind the interface board.

4. Dismount the component to be replaced and install the new component, being sure that any required spacers, insulation, washers, etc. are in place.

NOTE: If more room to work is required, the control panel frame and top cap assembly may be removed by removing the hex head screws that secure it to the fryer cabinet (see illustration below). If this option is chosen, all control panel assemblies must be removed per steps 1 and 2 above. The cover plate on the lower front of the component box may also be removed if desired. *Removing the component box itself from the fryer is not recommended due to the difficulty involved in disconnecting and reconnecting the oil-return valve rods, which pass through openings in the component box.*

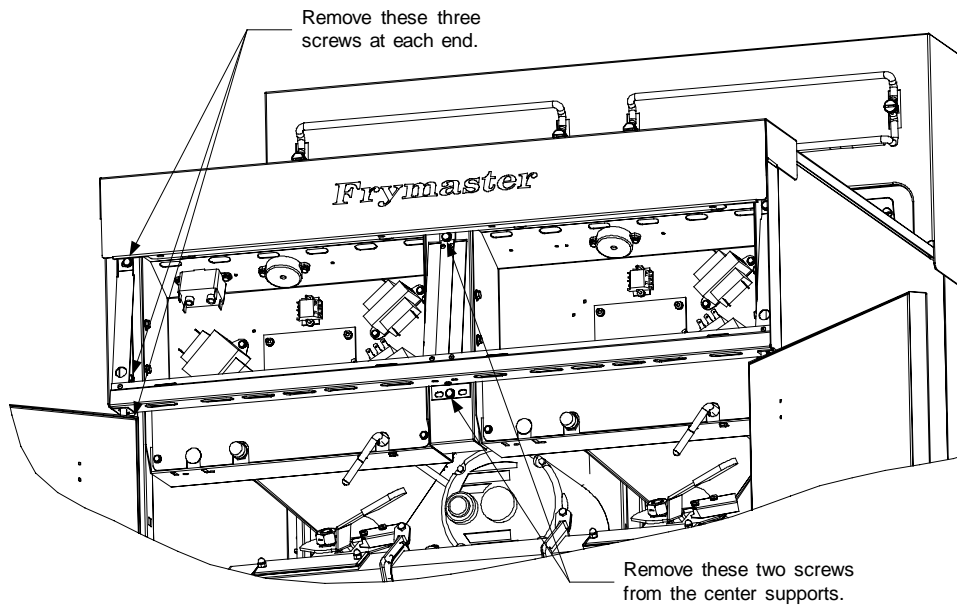

Removing the Control Panel Frame and Top Cap Assembly

5. Reconnect the wiring disconnected in step 3, referring to your notes and the wiring diagrams on the fryer door to ensure that the connections are properly made. Also, verify that no other wiring was disconnected accidentally during the replacement process.
6. Reverse steps 1 and 2 to complete the replacement and return the fryer to service.

1.4 Replacing a Temperature Probe or High-Limit Thermostat

1. Remove the filter pan and lid from the unit. Drain the frypots into a Shortening Disposal Unit (SDU) or other appropriate metal container.

⚠ DANGER
DO NOT drain more than one full frypot or two split frypots into the SDU at one time.

2. Disconnect the fryer from the electrical power supply and reposition it to gain access to the rear of the fryer.
3. Remove the tilt housing and back panels from the fryer. The tilt housing must be removed first in order to remove the upper back panel. To remove the tilt housing, raise the elements and allow them to rest on the basket support racks as shown in the photo below.



Next, remove the hex head screws from the rear edge of the housing. The housing can then be lifted straight up and off the fryer. Lift up on the upper back panel to disengage the tabs on its upper corners from the cutouts in the fryer frame.

4. Disconnect the wire harness at connector C6 and, using a pin pusher, disconnect the probe leads or high-limit leads from the connector.
5. ***If replacing a temperature probe***, remove the screw securing the probe bracket to the element and slide the bracket off the element and probe. Pull the probe out of the tilt housing assembly, install the replacement probe, and reattach the element bracket. Secure the upper portion of the probe with a replacement metal wire tie.

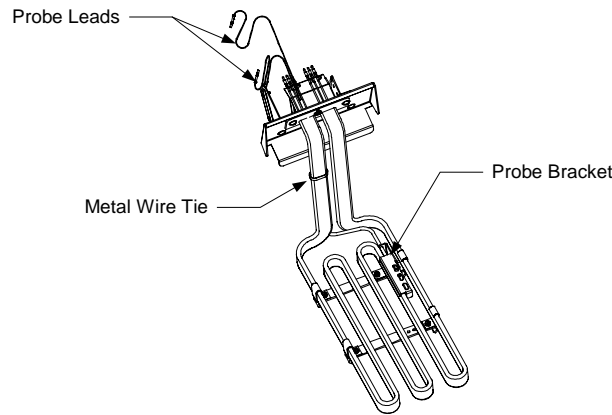

If replacing a high-limit thermostat, unscrew the thermostat to be replaced. Apply Loctite™ PST 567 or equivalent sealant to the threads of the replacement and screw it securely into the frypot.

6. ***If a temperature probe was replaced***, insert the probe leads into the connector (see left illustration below). For full-vat units or the left half (as viewed from the rear of the fryer) of a dual-vat unit, the red lead goes into position 6 and the white into position 7. For the right half of a dual-vat unit (as viewed from the rear of the fryer), the red lead goes into position 12 and the white into position 13.

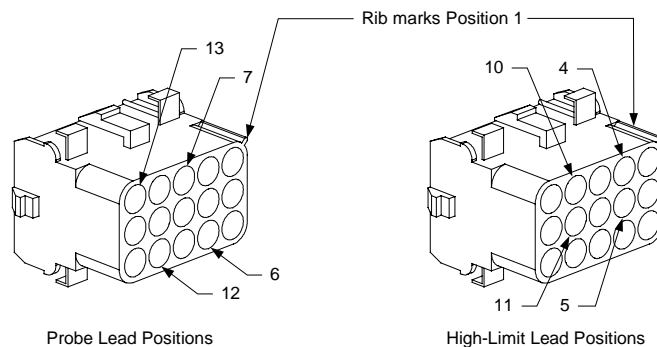

If a high-limit thermostat was replaced, insert the leads into the connector (see right illustration above). For full-vat units or the left half of a dual-vat unit (as viewed from the rear of the fryer), the leads go into positions 4 and 5 of the connector. For the right half of a dual-vat unit (as viewed from the rear of the fryer), the leads go into positions 10 and 11. In either case, polarity does not matter.

7. Reinstall the back panels and tilt housing to complete the installation, then reverse steps 1 and 2 to return the fryer to service.

1.5 Replacing a Heating Element

1. Perform steps 1-3 of section 1.4, *Replacing a Temperature Probe*.
2. On dual-vat fryers, and on full-vat fryers where the temperature probe is attached to the element being replaced, disconnect the wire harness containing the probe wiring (connector C6). Using a pin pusher, disconnect the probe wires from the connector.
3. On the front of the contactor box, disconnect the 6-pin connector for the left element (as viewed from the front of the fryer) or the 9-pin connector for the right element and pull the harness out through the rear of the fryer. Press in on the tabs on each side of the connector while pulling outward on the free end to extend the connector and release the element leads (see photo below). Pull the leads out of the connector and out of the plastic wire loom.

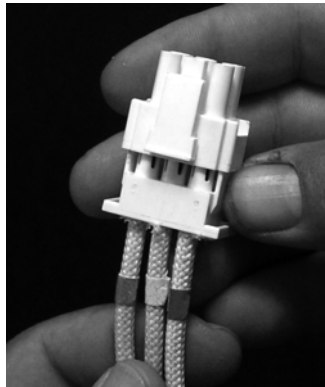

4. Raise the element to the full up position and disconnect the element springs.
5. Remove the nuts and machine screws that secure the element to the tilt plate assembly and pull the element out of the frypot. **NOTE:** Full-vat elements consist of two dual-vat elements clamped together. For full-vat units, remove the element clamps before removing the nuts and machine screws that secure the element to the tilt plate assembly.
6. If applicable, recover the probe bracket and probe from the element being replaced and install them on the replacement element, then install the replacement element in the frypot, securing it with the nuts and screws removed in Step 5.
7. Route the element leads through the wire loom to prevent chafing and press the pins into the connector in accordance with the diagram below, then close the connector to lock the leads in place. **NOTE:** It is critical that the wires be routed through the loom to prevent chafing.

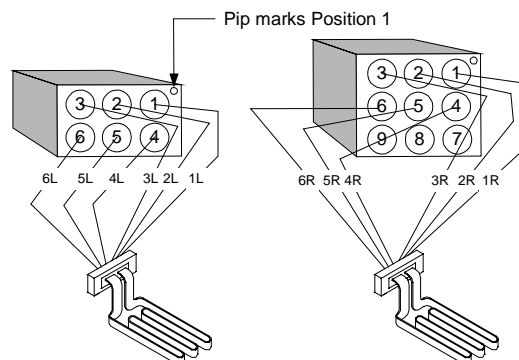

8. Insert the element connector into the receptacle on the front of the contactor box, ensuring that the latches lock.
9. If disconnected in step 2, insert the temperature probe leads into the wiring harness connector (see illustration below). For full-vat units or the right half of a dual-vat unit, the red lead goes into position 6 and the white into position 7. For the left half of a dual-vat unit, the red lead goes into position 12 and the white into position 13. **NOTE:** *Right* and *left* refer to the fryer as viewed from the rear.

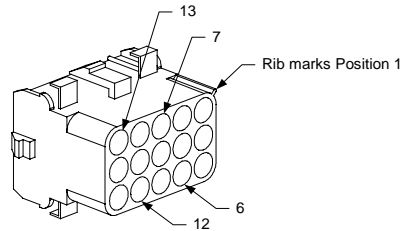

10. If disconnected in step 2, reconnect connector C6 of the wiring harness.
11. Reconnect the element springs and lower the element back down onto the basket rack.
12. Reinstall the tilt housing and back panels, reposition the fryer under the exhaust hood, and reconnect it to the electrical power supply.

1.6 Replacing Contactor Box Components

1. If replacing a contactor box above the built-in filter system, remove the filter pan and lid from the unit. Drain the frypots into a Shortening Disposal Unit (SDU) or other appropriate metal container. If replacing a contactor box in a non-filter unit, drain the frypot above the box into a Shortening Disposal Unit (SDU) or other appropriate metal container.

⚠ DANGER

DO NOT drain more than one full frypot or two split frypots into the SDU at one time.

2. Disconnect the fryer from the electrical power supply.
3. Unplug the wiring harnesses from the contactor box to be serviced.
4. Remove the two screws that secure the box in place. **NOTE:** If you remove the screws from both boxes at the same time, the boxes will jam against each other and neither can be removed.

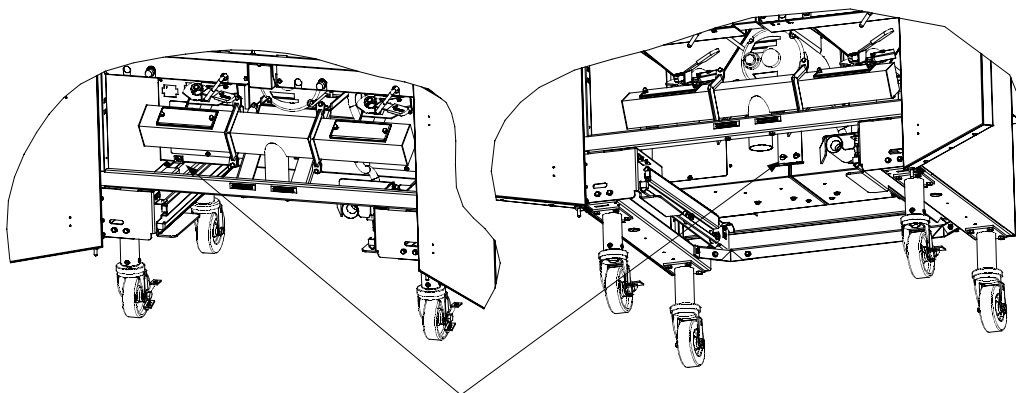

Remove these screws to dismount the left contactor box. The right contactor box is secured in a similar manner.

5. Carefully lower the box to the floor and pull it out the front of the fryer. Remove the top cover to access contactors and other components.
6. After performing necessary service, reverse steps 1-5 to return the fryer to operation.

1.7 Replacing a Frypot

1. Drain the frypot into the filter pan or, if replacing a frypot over the filter system, into a Shortening Disposal Unit (SDU) or other appropriate metal container. If replacing a frypot over the filter system, remove the filter pan and lid from the unit.



DO NOT drain more than one full frypot or two split frypots into the SDU at one time.

2. Disconnect the fryer from the electrical power supply and reposition it to gain access to both the front and rear.
3. On **Euro-look models**, slide the metal bezel up to release the bottom tabs; then, remove it.
4. On **all** models, remove the two screws from the upper corners of the control panels and allow them to swing down (see illustration and photo on page 1-1).
5. Unplug the wiring harnesses and ground wires from the backs of the controllers. Remove the controllers by lifting them from the hinge slots in the control panel frame.
6. Remove the tilt housing and back panels from the fryer. The tilt housing must be removed first in order to remove the upper back panel. To remove the tilt housing, raise the elements and allow them to rest on the basket support racks (see photo on page 1-3).

Next, remove the hex head screws from the rear edge of the housing. The housing can then be lifted straight up and off the fryer. Lift up on the upper back panel to disengage the tabs on its upper corners from the cutouts in the fryer frame.

7. Dismount the top cap by removing the hex head screws at each end that secure it to the control panel frame.
8. Remove the hex head screw that secures the front of the frypot to the cabinet cross brace.
9. Remove the top-connecting strip that covers the joint with the adjacent frypot.
10. On **standard models**, unscrew the Teflon vent/vacuum-breaker tube fitting, open the drain tube cleanout covers, unscrew the retainer nuts from the drain valve nipples, and remove the tube assembly from the fryer.

On **Euro-look models**, unscrew the Teflon vent/vacuum-breaker tube fitting, unscrew the nut located on the front of each section of drain tube, and remove the tube assembly from the fryer.

11. Remove the covers from the drain safety switch(es) and disconnect the switch wiring at the switch(es).

12. At the rear of the fryer, unplug the C6 connector and, using a pin pusher, disconnect the high-limit thermostat leads.
13. Disconnect the oil return flexline(s) at the frypot end(s).
14. Raise the elements to the “up” position and disconnect the element springs.
15. Remove the machine screws and nuts that secure the tilt plate and element assembly to the frypot. Carefully lift the tilt plate and element assembly from the frypot and secure it to the cross brace on the rear of the fryer with wire ties or tape.
16. Carefully lift the frypot from the fryer and place it upside down on a stable work surface.
17. Recover the drain valve(s), oil return flexline connection fitting(s), and high-limit thermostat(s) from the frypot. Apply Loctite™ PST 567 or equivalent sealant to the threads of the recovered parts and install them in the replacement frypot.
18. Carefully lower the replacement frypot into the fryer. Reinstall the hex head screw removed in step 7 to attach the frypot to the fryer.
19. Position the tilt housing and element assembly in the frypot and reinstall the machine screws and nuts removed in step 14.
20. Reconnect the oil return flexlines to the frypot, and replace aluminum tape, if necessary, to secure heater strips to the flexlines.
21. Insert the high-limit thermostat leads disconnected in step 11 (see illustration on page 1-4 for pin positions).
22. Reconnect the drain safety switch wiring to the switch(es) in accordance with the diagram below then reinstall the switch covers.

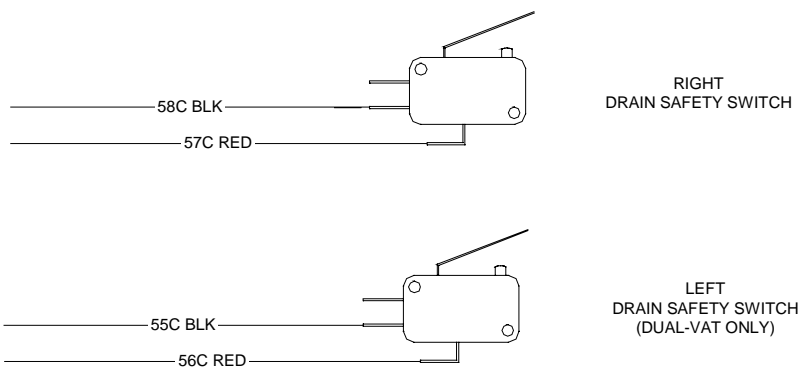

23. Reinstall the drain tube assembly.
24. Reinstall the tilt housing and back panels, top cap, and top connecting strip.
25. Reinstall controllers in the control panel frame and reconnect the wiring harnesses and ground wires.
26. Reposition the fryer under the exhaust hood and reconnect it to the electrical power supply.

1.8 Built-in Filtration System Service Procedures

1.8.1 Filtration System Problem Resolution

One of the most common causes of filtration problems is placing the filter paper on the bottom of the filter pan rather than over the filter screen.

⚠ CAUTION
Ensure that filter screen is in place prior to filter paper placement and filter pump operation. Improper screen placement is the primary cause of filtration system malfunction.

When the complaint is “the pump is running, but no oil is being filtered,” check the installation of the filter paper and ensure that the correct size is being used.

If the pump motor overheats, the thermal overload will trip and the motor will not start until it is reset. If the pump motor does not start, press the red reset switch (button) located on the rear of the motor at the front of the fryer.

If the pump starts after resetting the thermal overload switch, then something is causing the motor to overheat. A major cause of overheating is when several frypots are filtered sequentially, thus overheating the pump and motor. Allow the pump motor to cool at least 30 minutes before resuming operation. Pump overheating can be caused by:

- Solidified shortening in the pan or filter lines, or
- Attempting to filter unheated oil (cold oil is more viscous, overloading the pump motor and causing it to overheat).

If the motor runs but the pump does not, there is a blockage in the pump. Incorrectly sized or installed paper/pads will allow food particles and sediment to pass through the filter pan and into the pump. When sediment enters the pump, the gears bind, causing the motor to overload, again tripping the thermal overload. Shortening that has solidified in the pump will also cause it to seize, with the same result.

A pump seized by debris or hard shortening can usually be freed by manually moving the gears with a screwdriver or other instrument.

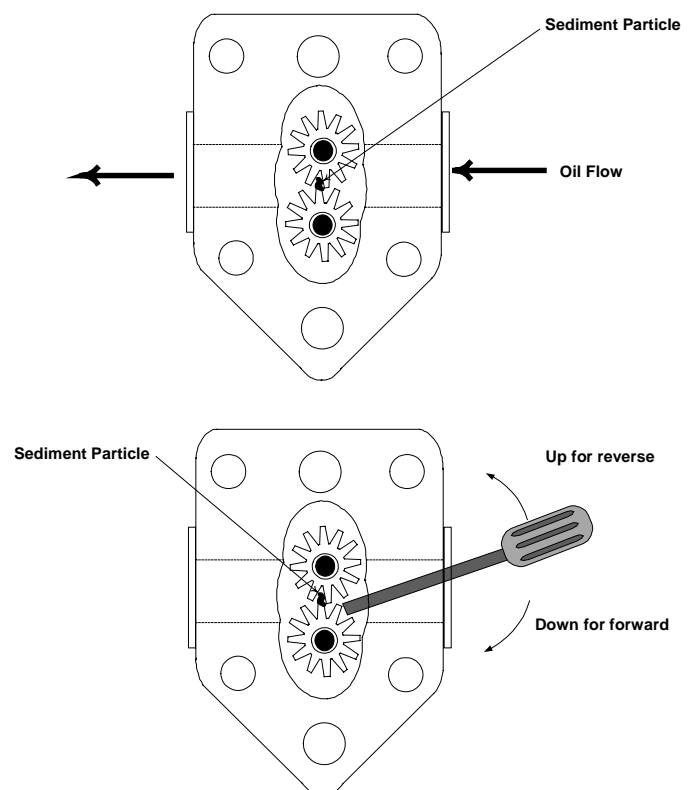

Disconnect power to the filter system, remove the input plumbing from the pump, and use a screwdriver to manually turn the gears.

- Turning the pump gears in reverse will release a hard particle.
- Turning the pump gears forward will push softer objects and solid shortening through the pump and allow free movement of the gears.

Incorrectly sized or installed paper/pads will also allow food particles and sediment to pass through and clog the suction tube on the bottom of the filter pan. Particles large enough to block the suction tube may indicate that the crumb tray is not being used. Pan blockage can also occur if shortening is left in the pan and allowed to solidify. Blockage removal can be accomplished by forcing the item out with an auger or drain snake. Compressed air or other pressurized gases should not be used to force out the blockage.

1.8.2 Replacing the Filter Motor, Filter Pump, and Related Components

1. Remove the filter pan and lid from the unit. Drain the frypots into a Shortening Disposal Unit (SDU) or other appropriate metal container.

⚠ DANGER
DO NOT drain more than one full frypot or two split frypots into the SDU at one time.

2. Disconnect the fryer from the electrical power supply and reposition it to gain access to both the front and rear.
3. Remove the two lower back panels, unplug the wiring harnesses from the contactor boxes, and remove the two screws that secure one of the boxes in place (it doesn't matter which one; see illustration on page 1-6). **NOTE:** If you remove the screws from both boxes at the same time, the boxes will jam against each other and neither can be removed.
4. Carefully lower the box to the floor and pull it out the front of the fryer. Remove the remaining box following the same procedure.
5. Disconnect the two flexlines running to the oil-return manifold at the rear of the fryer. Remove the nut and bolt that secures the bridge to the oil-return manifold.

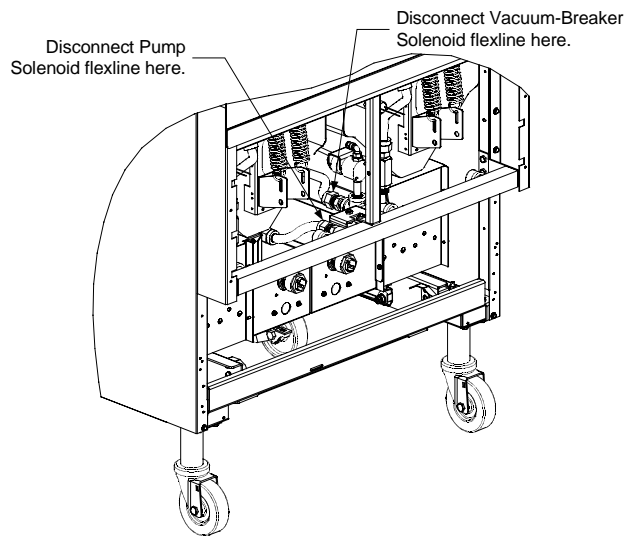

6. Disconnect the pump suction flexline at the end of the filter pan connection.

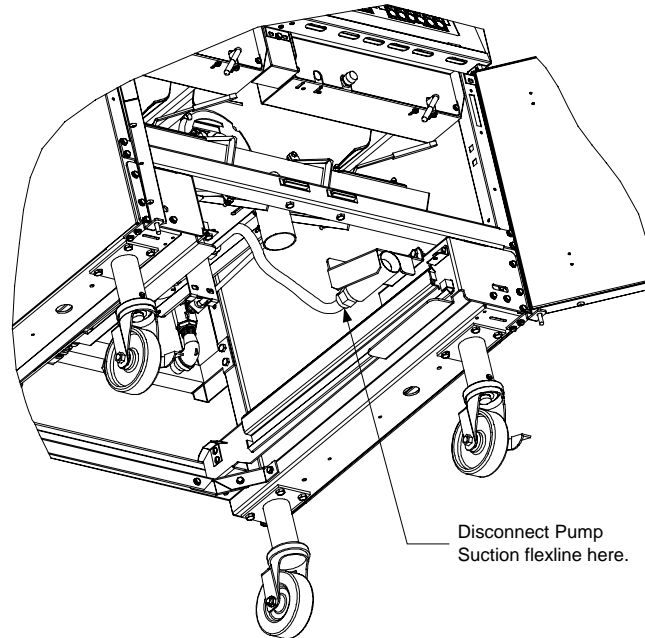

7. Remove the cover plate from the front of the motor and disconnect the motor wires.
8. Unplug the 15-pin connector from the rear of the left component box and, using a pin pusher, disconnect the solenoid valve wires (pins 4, 6, 10 and 12). **NOTE:** If the vacuum-breaker solenoid valve is connected to the manifold rather than the pump, its wires (pins 4 and 6) do not need to be disconnected.
9. Remove the two nuts and bolts that secure the front of the bridge to the cross brace and carefully slide the bridge rearward off the cross brace until its front end can be lowered to the floor. Be careful not to let the rear of the bridge slip off the manifold at this point. **NOTE:** In some early production units, the bridge will not slide far enough to the rear to clear the front brace. In such cases, the front brace must be removed. It is held in place by two hex head screws on each end and a nut and bolt inside the brace near each end.
10. Get a good grip on the bridge, carefully pull it forward off the oil-return manifold, and lower the entire assembly to the floor. Once on the floor, pull the assembly out the front of the fryer.
11. When required service has been completed, reverse steps 6-12 to reinstall the bridge. **NOTE:** The black motor wires go on the top terminal, the white on the bottom. The pump solenoid valve wires go in positions 10 and 12 of the 15-pin connector; the vacuum-breaker solenoid valve wires go in positions 4 and 6. In both cases, polarity does not matter.
12. Once the bridge is back in place, reverse steps 4 and 5 to reinstall the contactor boxes.
13. Reconnect the unit to the electrical power supply, and verify that the pump is functioning correctly (i.e., when a filter handle is placed in the ON position, the motor should start and there should be strong suction at the intake fitting and outflow at the power shower or rear flush port).
14. When proper operation has been verified, reinstall the back panels and the filter pan and lid, and return the fryer to service.

1.8.3 Replacing the Filter Transformer or Filter Relay

Remove the left controller from the fryer to expose the interior of the left component box. The filter transformer and relay are located as shown in the illustration below. **NOTE:** The right component box is identical to the left except that the filter transformer and relay are not present.

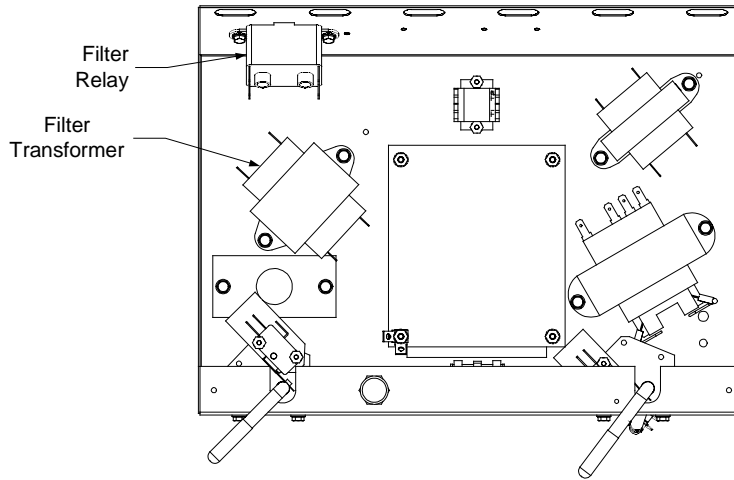

Dual-vat configuration illustrated. In full-vat units, left filter handle is not present.

1.9 Basket Lift Service Procedures

Pro Series electric fryers may be equipped with automatic basket lifts. Basket lifts always come in pairs, although each operates independently.

A **modular basket lift** (illustrated below) is a self-contained sub-assembly consisting of a pair of toothed rods which support removable basket lift arms, a pair of reversible-drive gear motors, and four microswitches. The gear motors engage the teeth of the rods, moving them up or down depending upon the motors' direction of rotation. The microswitches at the upper and lower limits of movement stop the motors when the basket is in the full up or full down position.

Timing circuitry in the controller initiates and stops basket lift operation depending upon the variables programmed by the operator. When the product button is pressed, the timing circuitry activates a coil in the basket lift relay to supply power to the lower microswitch. The microswitches stop the motor at the lift's upper and lower travel limits and reverse the direction of current flow thus reversing the motor direction.

When the product button is pushed on the computer/controller, current flows through a coil in the basket lift relay, causing the lower circuit to be activated. The basket lift lowers, closing the normally open upper-micro-switch. When the downward-moving rod opens the lower normally closed microswitch, power to the motor ceases to flow. When the computer/controller times out, the current to the relay coil is cut, allowing the upper circuit to be activated. The basket lift then raises and re-closes the lower microswitch. When the basket lift rod clears the upper microswitch, the microswitch reopens, power to the circuit is cut, and the motor stops. Pushing the product button restarts the cycle.

Problems with the basket lift can be grouped into three categories:

- Binding/jamming problems
- Motor and gear problems
- Electronic problems

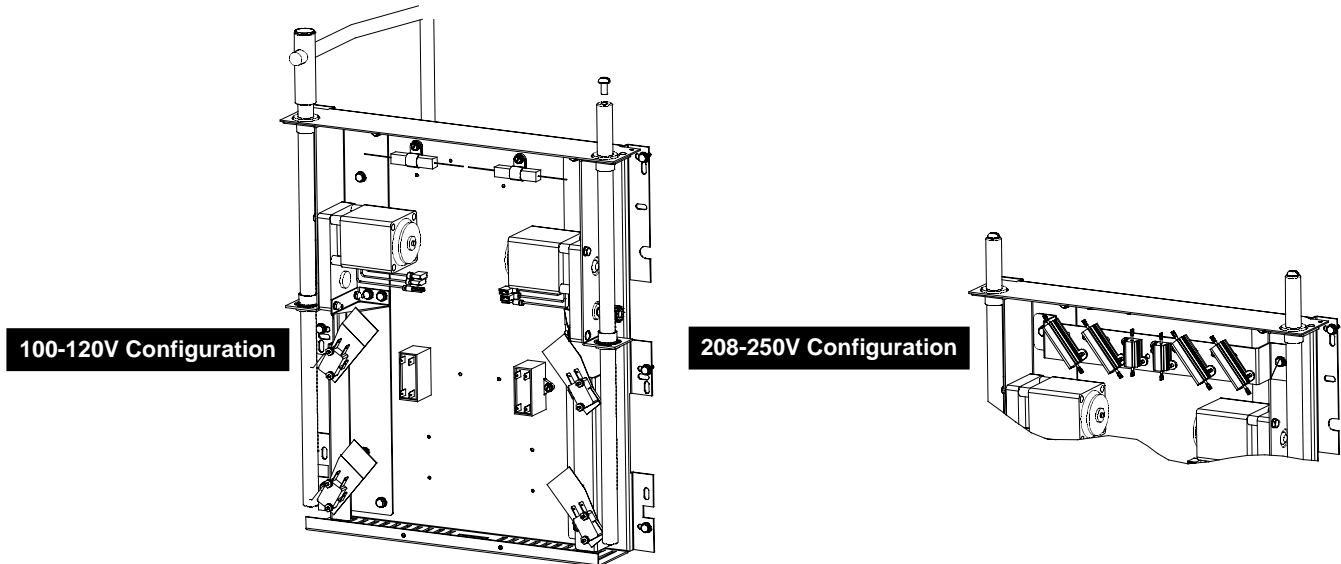

BINDING/JAMMING PROBLEMS

Noisy, jerky or erratic movement of the lifts is usually due to lack of lubrication of the rods and their bushings. Apply a light coat of Lubriplate[®] or similar lightweight white grease to the rod and bushings to correct the problem.

With the modular basket lift, another possible cause of binding is improper positioning of the motor, which prevents the gear from correctly engaging the teeth in the rod. To correct the problem, loosen the screws that hold the motor in place and move it forward or backward until the rod has just enough slack to be rotated slightly.

MOTOR AND GEAR PROBLEMS

With the modular basket lift, the most likely problem to be encountered in this category is erratic motion of the lift due to a worn drive gear. Failure to keep the lift rod and bushings properly lubricated will cause unnecessary wear of the gear. The problem is corrected by replacing the worn gear.

If the lift cycles correctly but fails to remain in the up position (i.e., goes up, but then slowly settles back down into the frypot), the problem is a failed motor brake. A failed motor brake cannot be repaired and requires replacement of the motor itself.

If power is reaching the motor but the motor fails to run, the motor is burned out and must be replaced.

ELECTRONIC PROBLEMS

Within this category are problems associated with the relays, microswitches, capacitors, resistors, interface board, wiring, and controls. The most common problem in this category is a lift that continuously travels up and down. This is usually caused by a microswitch that is out of adjustment. Troubleshooting the electronics of a modular basket lift is simply a process of verifying current flow through the individual components up to and including the motor. Using a multimeter set to the 250 VAC range, check the connections on both sides of the component for the presence of the applied line voltage. The schematic below and the wiring diagram on page 1-15 identify the components and wiring connection points.

1.10 Interface Board Diagnostic Chart

The following diagram and charts provide ten quick system checks that can be performed using only a multimeter.

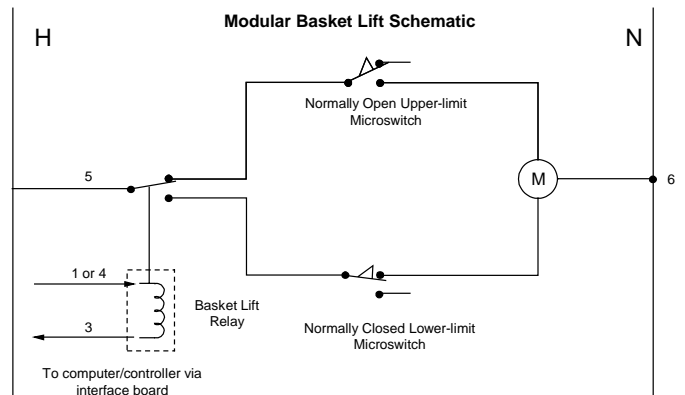
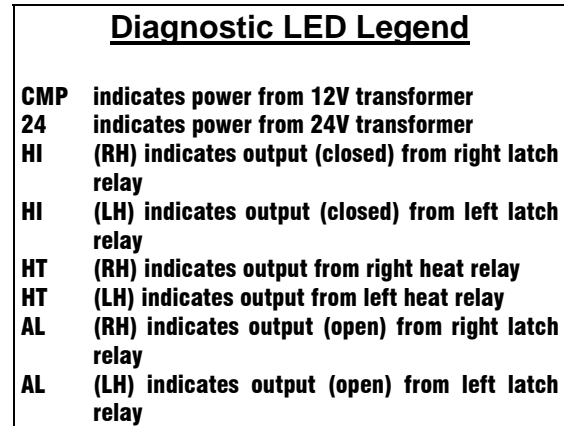
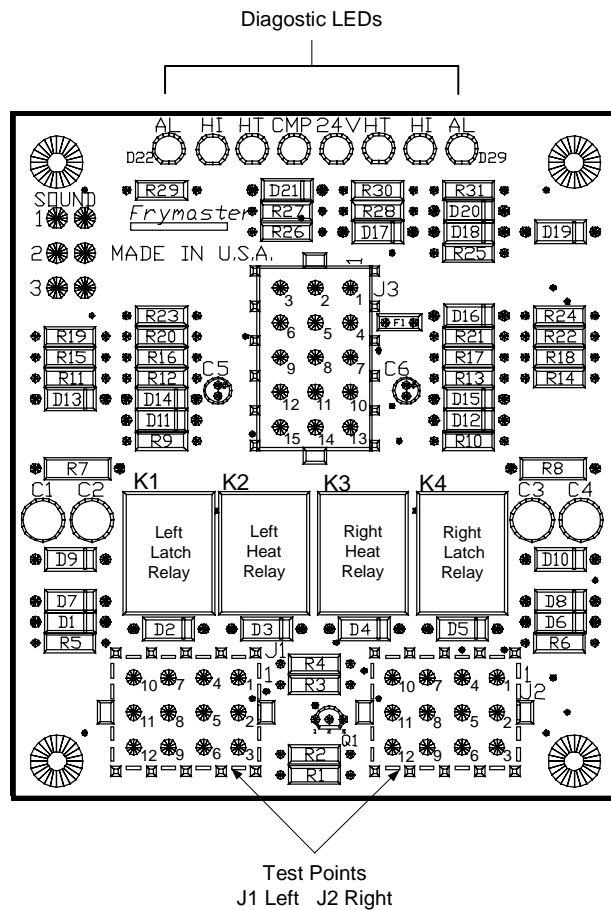

Meter Setting	Test	Pin	Pin	Results
12 VAC Power	50 VAC Scale	1 of J2	3 of J2	12-16 VAC
24 VAC Power	50 VAC Scale	2 of J2	Chassis	24-30 VAC
*Probe Resistance (RH)	R X 1000 OHMS	11 of J2	12 of J2	See Chart
*Probe Resistance (LH)	R X 1000 OHMS	3 of J1	2 of J1	See Chart
Hi-Limit Continuity (RH)	R X 1 OHMS	7 of J2	4 of J2	0 - OHMS
Hi-Limit Continuity (LH)	R X 1 OHMS	4 of J1	7 of J1	0 - OHMS
Latch Contactor Coil (RH)	R X 1 OHMS	8 of J2	Chassis	3-10 OHMS
Latch Contactor Coil (LH)	R X 1 OHMS	5 of J1	Chassis	3-10 OHMS
Heat Contactor Coil (RH)	R X 1 OHMS	9 of J2	Chassis	18-25 OHMS
Heat Contactor Coil (LH)	R X 1 OHMS	6 of J1	Chassis	18-25 OHMS

* Disconnect 15-Pin harness from the computer/controller before testing the probe circuit.

1.11 Wiring Diagrams

BASKET LIFT

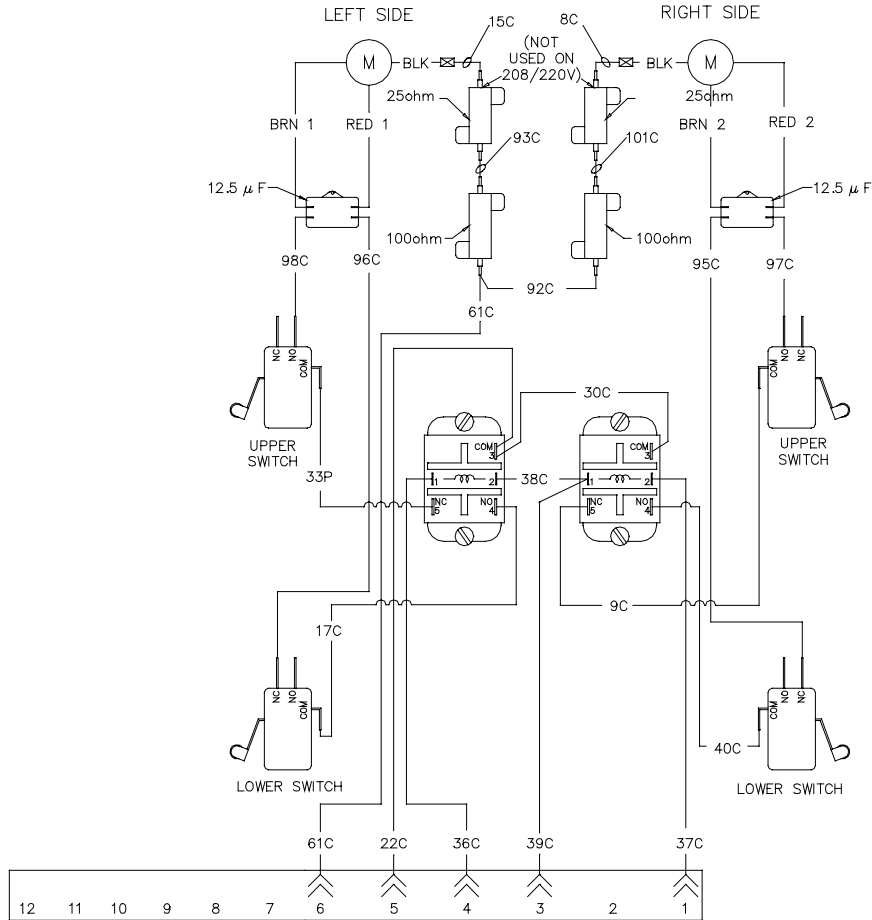

REFERENCES TO LEFT & RIGHT ARE
FROM THE REAR OF THE FRYER

8050888C

COMPONENT WIRING

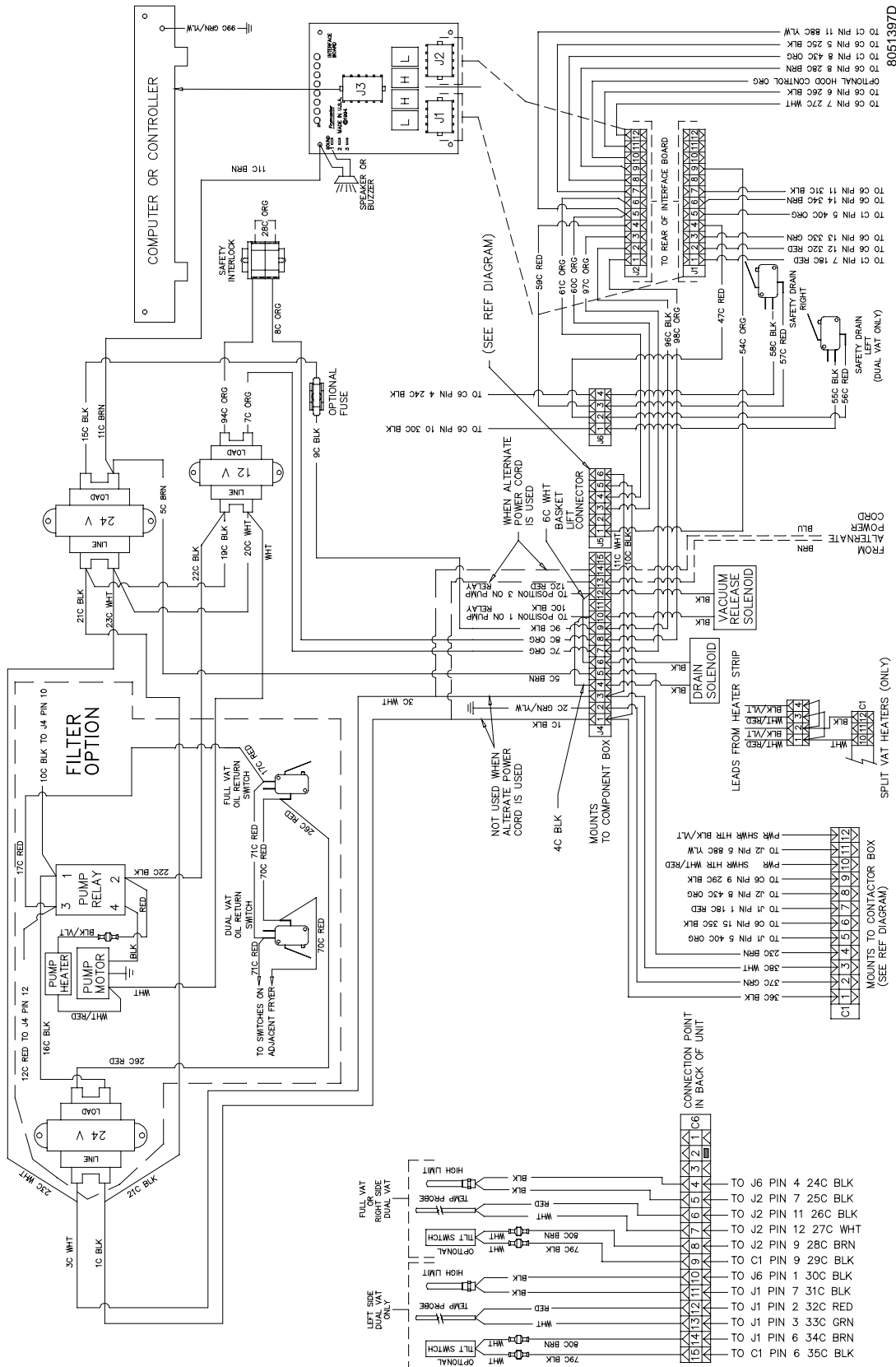

8051397D

CONTACTOR BOX – DELTA CONFIGURATION

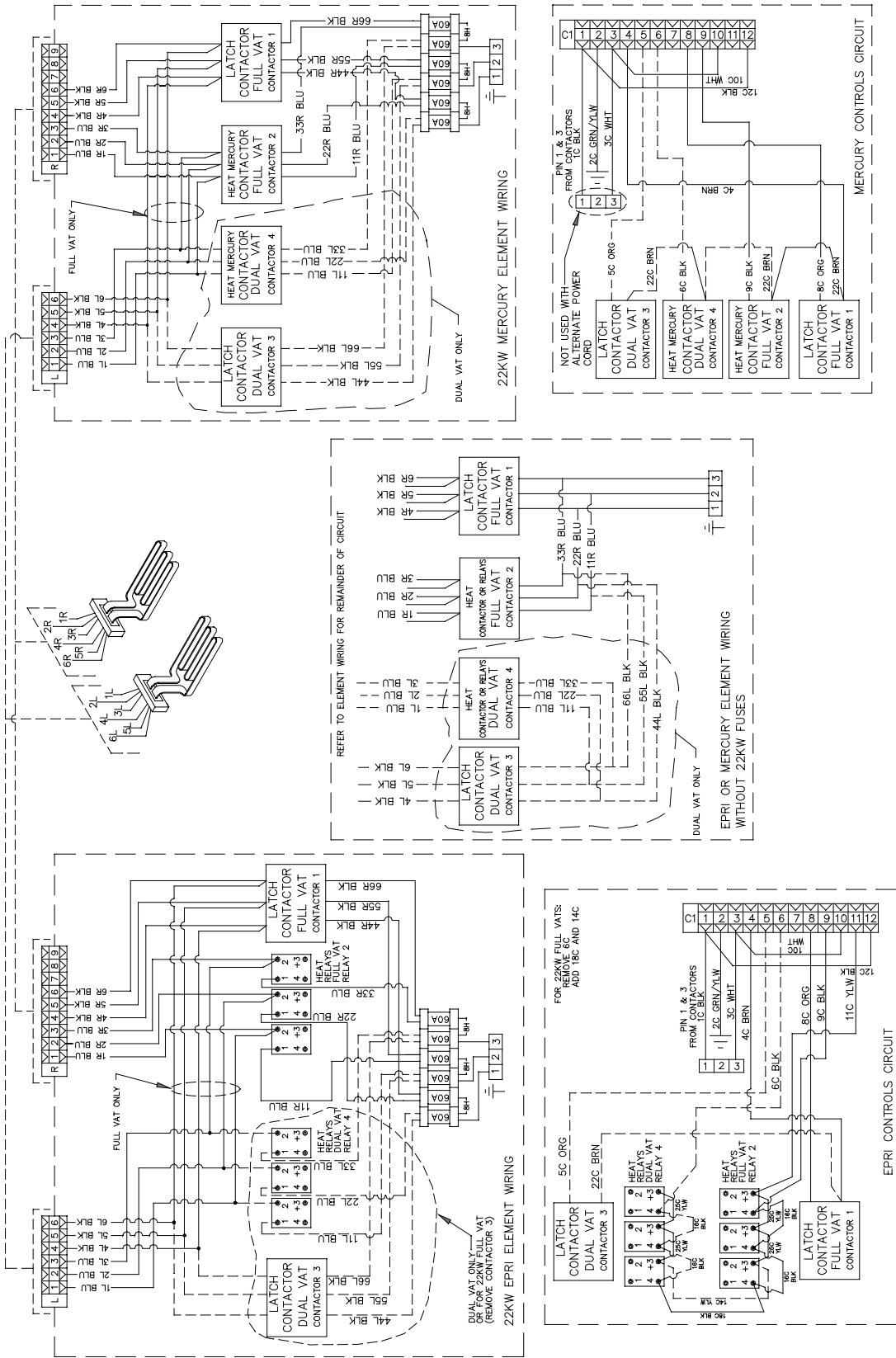

8051395B

CONTACTOR BOX – WYE CONFIGURATION

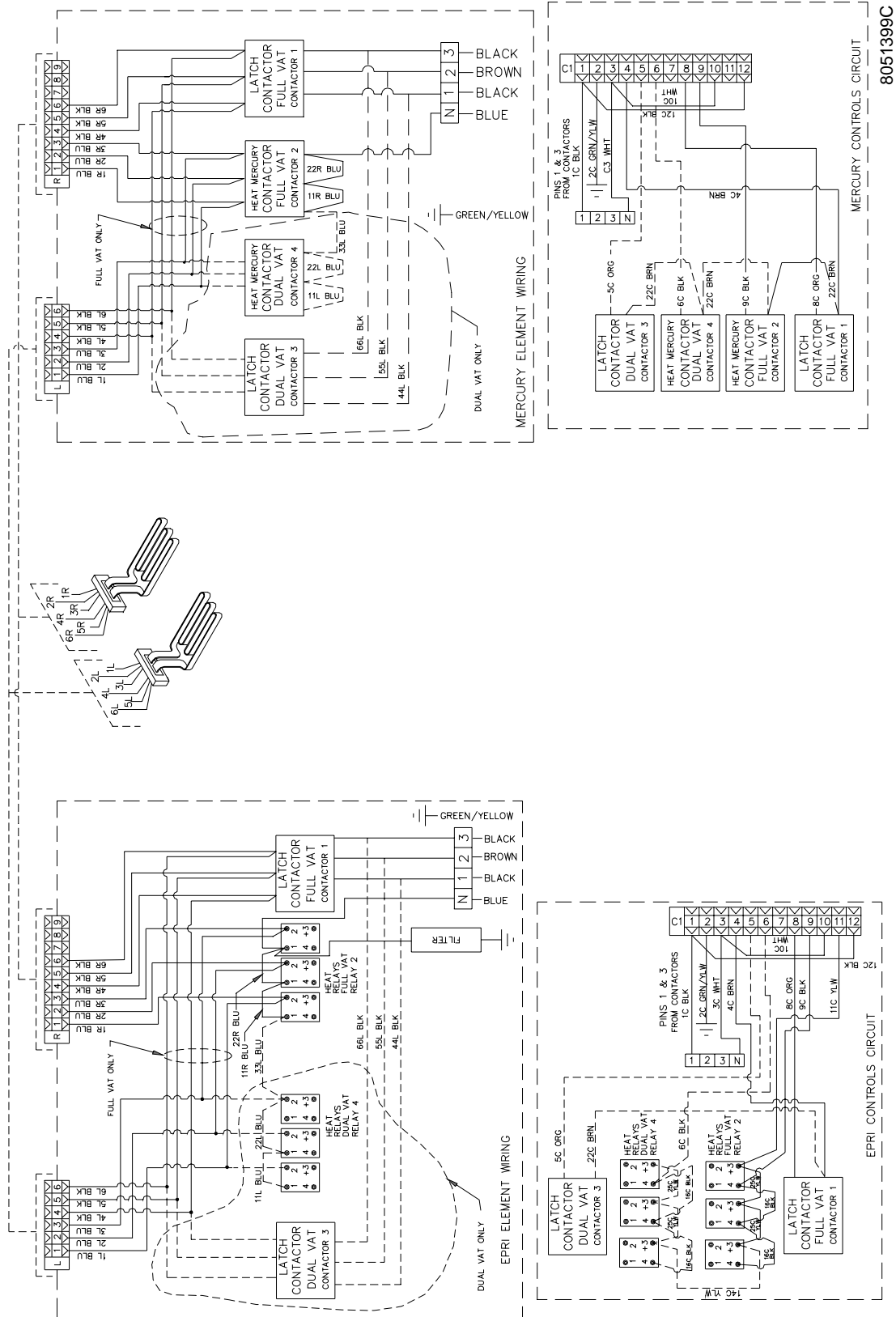

8051399C

PRO SERIES ELECTRIC FRYERS

CHAPTER 2: PARTS LIST

2.1 Accessories

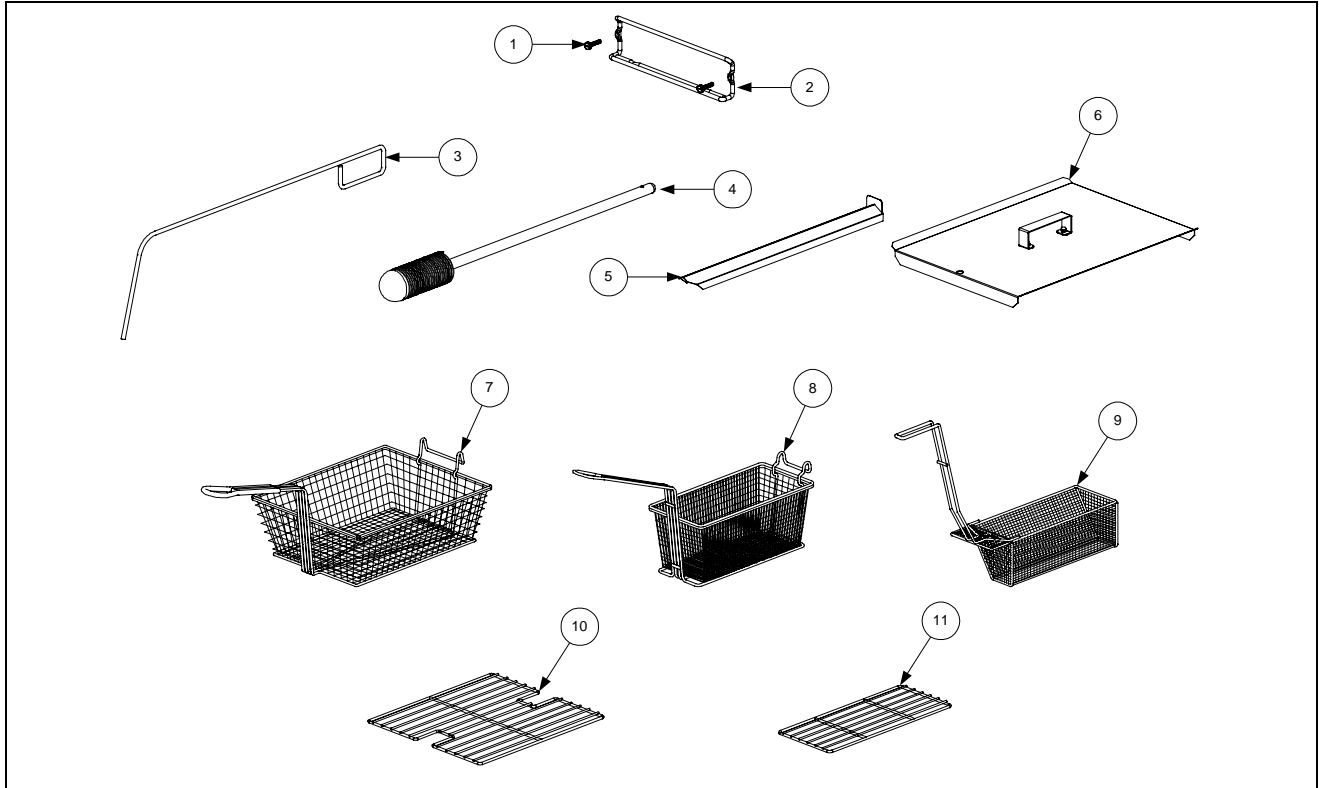

ITEM	STANDARD PART #	EURO-LOOK PART #	COMPONENT
1	809-0171		Thumbscrew, 1/4 -20 X 1 ³ / ₈ -inch
2	810-1403		Hanger, Wireform Basket
*	809-0921		Spacer, Basket Hanger
3	803-0197		Cleanout Rod, 27-inch
4	803-0209		Brush, Frypot
5	823-1885		Connecting Strip, Frypot
6	806-3068		Cover, Full-Vat Frypot
*	806-3071		Cover, Dual-Vat Frypot
7	803-0099		Basket, Full-Vat
8	803-0271		Basket, Dual-Vat (Twin)
9	803-0122		Sediment Tray, Left Dual-Vat
*	803-0123		Sediment Tray, Right Dual-Vat
*	803-0113		Sediment Tray, Full-Vat
10	803-0132		Rack, Full-Vat Basket Support
11	803-0106		Rack, Dual-Vat Basket Support
*	803-0002		Powder, Filter (80 1-Cup Applications)
*	803-0046		Cup, Plastic Measuring
*	803-0170		Pack, 100-Sheet Filter Paper

* Not illustrated.

■ Use standard part.

2.2 Basket Lift Assembly and Associated Parts

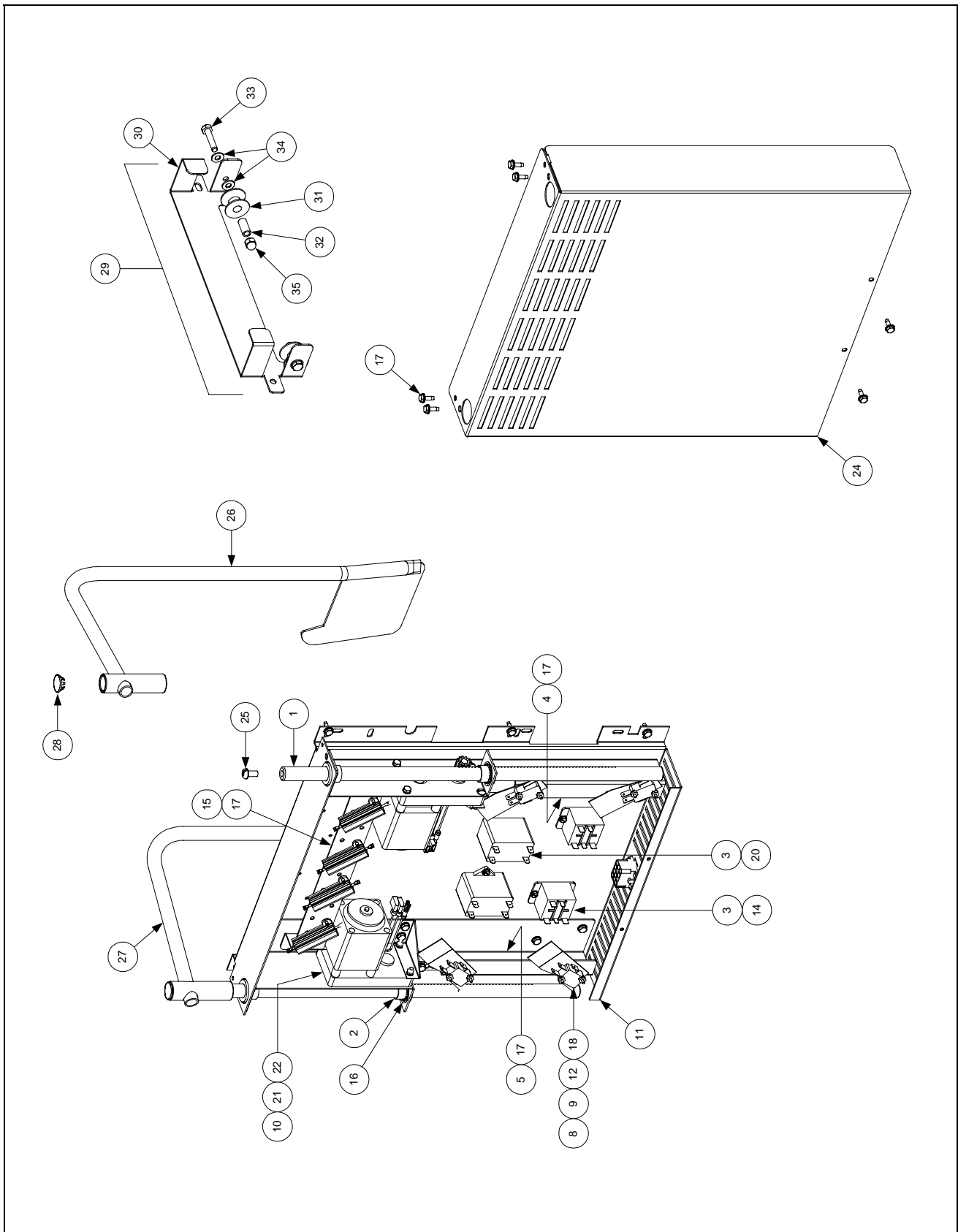

ITEM	STANDARD PART #	EURO-LOOK PART #	COMPONENT
	106-1805SP		Basket Lift Assembly, 200-220VAC w/Relay (<i>Items 1-23</i>)
1	810-1012		Rod, Basket Lift
2	813-0035		Bushing, Bronze
3	807-2513		Capacitor, 12.5 µFarad 330VAC
4	901-8499		Chassis, Left Basket Lift
5	902-8499		Chassis, Right Basket Lift
6	807-0159		Connector, 12-Pin Female
7	900-5529		Gusset, Basket Lift Motor
8	812-0442		Insulation, Microswitch
9	807-2572		Microswitch
10	806-5964SP		Motor Assembly, 208-240VAC Modular Basket Lift
11	200-2942		Mount, Modular Basket Lift
12	826-1366		Nut, 4-40 Hex Keps (Pkg. of 25)
13	809-0247		Nut, 8-32 Hex Keps
14	807-1683		Relay, 12VDC
15	106-2770SP		Resistor Assembly, 208-220VAC Modular Basket Lift
16	809-0082		Ring, Bushing Retainer
17	826-1374		Screw, #10 X ½-inch Hex Washer Head (Pkg. of 25)
18	826-1359		Screw, 4-40 X ¾-inch Slotted Round Head (Pkg. of 25)
19	826-1361		Screw, 8-32 X 1-inch Slotted Truss Head (Pkg. of 25)
20	826-1371		Screw, #8 X ½-inch Drill Point Hex Head (Pkg. of 25)
21	809-0503		Screw, 8-32 X ½-inch Hex Head
22	809-0186		Washer, #8 Lock
23	WIR-0166SP		Wire Bundle, 200-250VAC Basket Lift w/Relay
24	910-4776		Cover, Modular Basket Lift Rear S/S (<i>Use 900-4776 for Mild Steel</i>)
25	809-0127		Screw, ¼-20 X ½-inch Slotted Round Head
26	823-2704		Arm, Left Basket Lift
27	823-2705		Arm, Right Basket Lift
28	810-0179		Button, Plug
29	806-9110SP		Roller Assembly, Basket Lift
30	910-8112		Bracket, Basket Lift Roller
31	810-0194		Roller, Basket Lift
32	810-0374		Spacer, Basket Lift Roller
33	809-0508		Bolt, ¼-20 X 1¼ -Inch
34	809-0190		Washer, ¼-inch Flat
35	809-0047		Nut, ¼-20 Cap
*	807-3700		Wiring Harness, Pro Series Electric Basket Lift (<i>Plugs into Item 6</i>)

* Not illustrated.

■ Use standard part.

2.3 Cabinetry

2.3.1 Back Panels, Control Panel Frames, Doors, Sides, Tilt Housings, and Top Caps

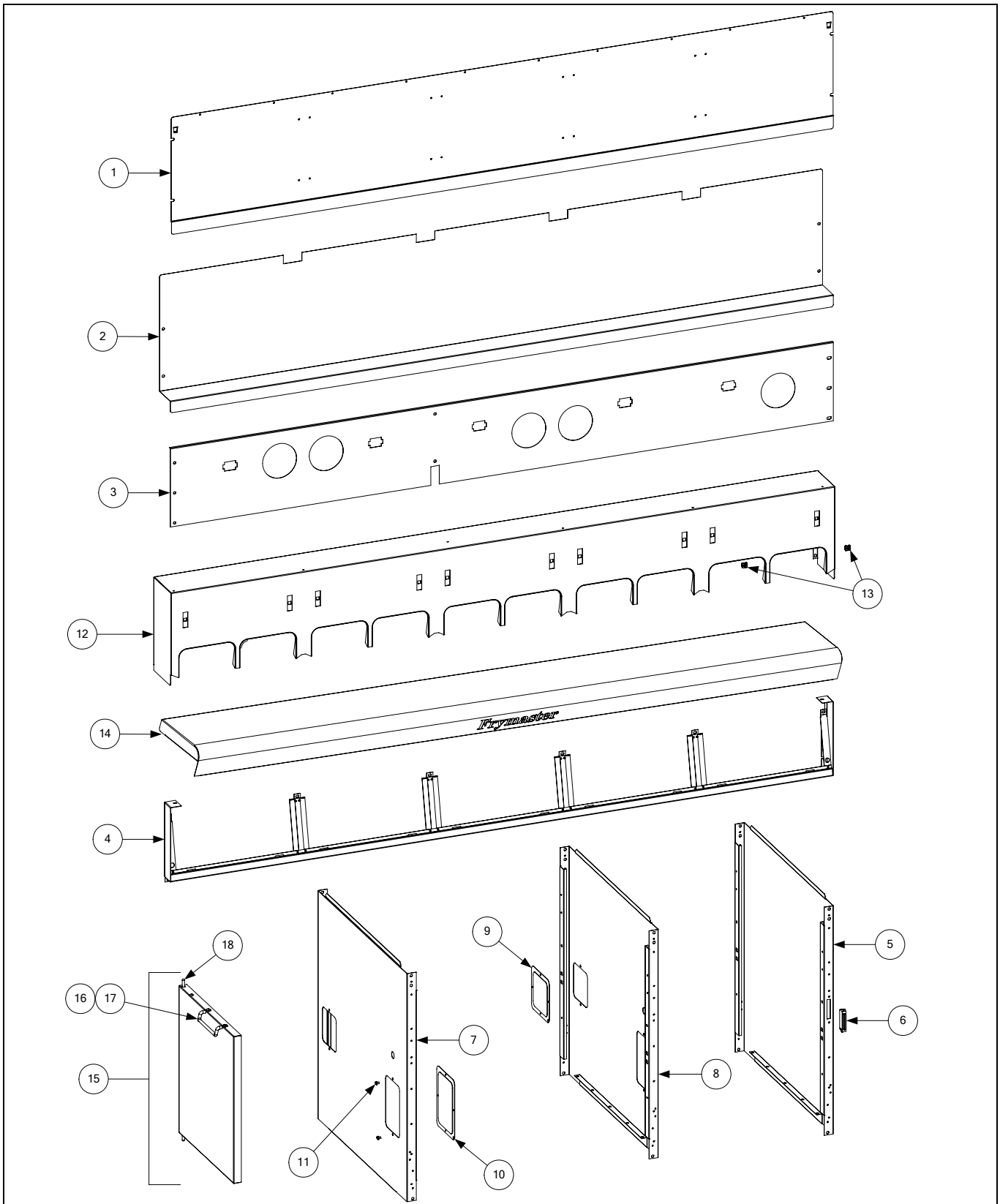

ITEM	STANDARD PART #	EURO-LOOK PART #	COMPONENT
1			Back Panel, Upper (Panel for five station fryer shown)
	210-2299	200-6630	Two Station Fryer
	210-2380	200-6785	Three Station Fryer
	210-3490	200-6786	Four Station Fryer
	210-3670	200-6787	Five Station Fryer
2			Back Panel, Center (Panel for five station fryer shown)
	210-2298	200-2298	Two Station Fryer
	210-2379	200-2379	Three Station Fryer
	210-3489	200-3489	Four Station Fryer
	210-3669	200-3669	Five Station Fryer
3			Back Panel, Lower (Panel for five station fryer shown)
	210-4430	200-4426	Two Station Fryer
	210-4431	200-4427	Three Station Fryer
	210-4432	200-4428	Four Station Fryer
	210-4433	200-4429	Five Station Fryer
4			Frame, Control Panel (Frame for five station fryer shown)
	806-7172SP	106-4378	Two Station Fryer (<i>use 106-5221SP for fryers mfd. After 6.22.05</i>)
	806-7173SP	106-4391	Three Station Fryer (<i>use 106-5018SP for fryers mfd. After 6.22.05</i>)
	806-7174SP	106-4392	Four Station Fryer (<i>use 106-5019 for fryers mfd. After 6.22.05</i>)
	106-2171SP	106-4393	Five Station Fryer (<i>use 106-5020 for fryers mfd. After 6.22.05</i>)
5	210-4435		Side, Standard Cabinet Left or Right
6	810-2346	810-1105	Magnet, Door
7	211-4616	201-8481	Side, Filter Ready Cabinet Left
8	212-4616	202-8481	Side, Filter Ready Cabinet Right
9	910-0889		Cover, 5-inch X 5-inch Access
10	910-0890		Cover, 5-inch X 7-inch Access
11	809-0359		Screw, #8 X ¼-inch Hex Washer Head
12			Tilt Housing (Housing for five station fryer shown)
	824-1061	824-1303	Two Station
	824-1062	824-1335	Three Station
	824-1063	824-1336	Four Station
	824-1065	824-1337	Five Station
13	826-1351	809-0015	Nut Retainer, ¼-20 (Pkg. of 10 – receives basket hanger thumbscrew)
14			Top Cap (Top cap for five station fryer shown)
	106-3033SP	106-4414	Two Station (<i>use 106-5196 for fryers mfd. After 6.22.05</i>)
	106-3035SP	106-4437	Three Station (<i>use 106-5197 for fryers mfd. After 6.22.05</i>)
	106-3036SP	106-4439	Four Station (<i>use 106-5198 for fryers mfd. After 6.22.05</i>)
	824-0890	106-4441	Five Station (<i>use 106-5199 for fryers mfd. After 6.22.05</i>)
15	806-6545SP	106-4397	Door, Left or Right (Left shown – move handle to opposite side for Right)
16	809-0266		Screw, #10 X ½-inch Phillips Truss Head
17	810-1422	210-6816	Handle, Wireform Door
18	106-0554		Pin Assembly, Door
*	810-0275		Spring, Door Pin

* Not illustrated.

Use standard part.

2.3.2 Cabinet Bases, Braces, and Associated Parts

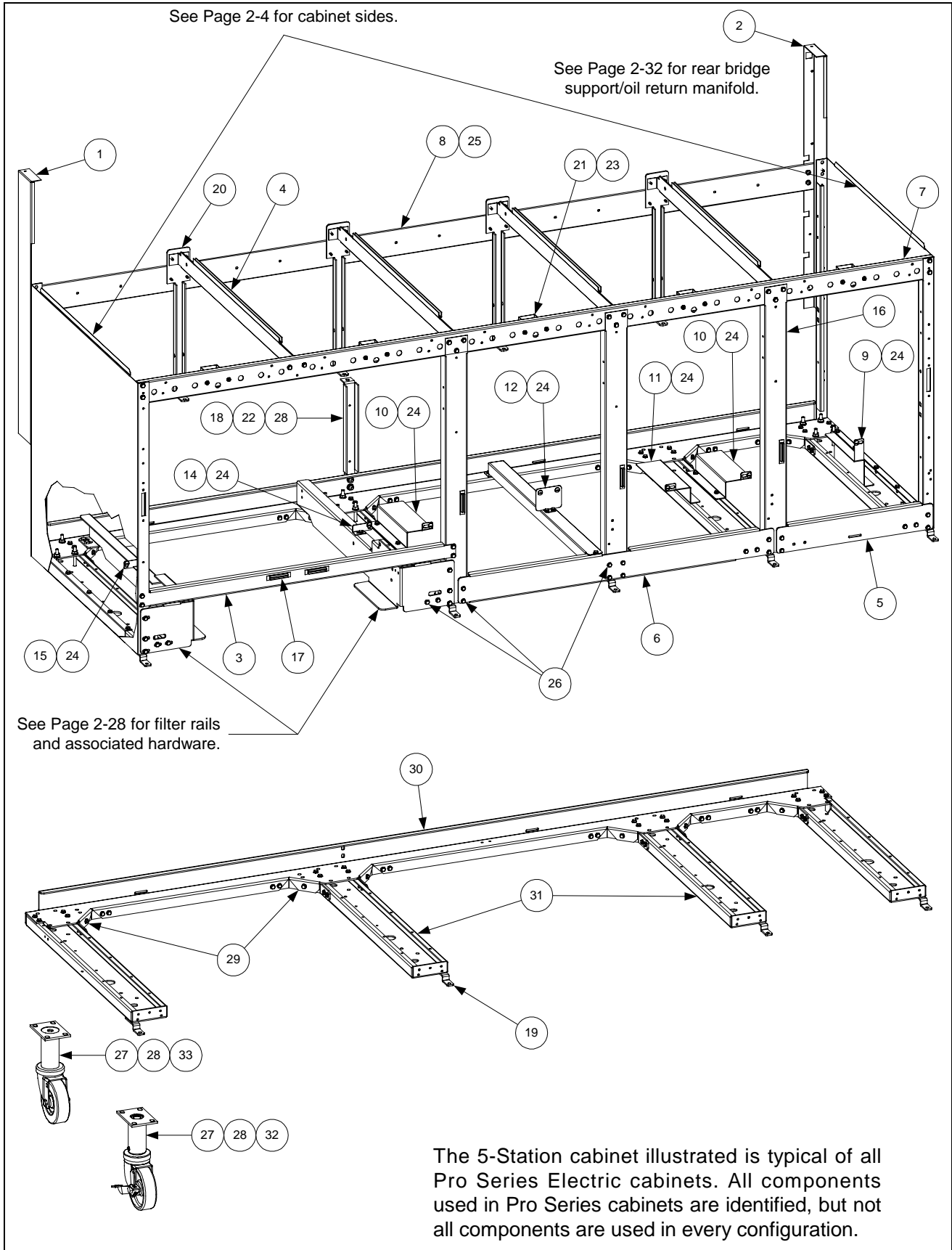

ITEM	STANDARD PART #	EURO-LOOK PART #	COMPONENT
1	106-1265SP		Upright Assembly, Left
2	106-1266SP		Upright Assembly, Right
3	200-1651		Support, Cross Cabinet
4	200-1659		Divider, Cabinet
5	200-2293		Brace, Single Station Lower
6	200-3774		Brace, Double Station Lower
7			Brace, Front Horizontal
	200-2331		Two-Station Fryer
	200-2296		Three-Station Fryer
	200-2733		Four-Station Fryer
	200-3590		Five-Station Fryer
8			Brace, Rear Horizontal
	200-2284		Two-Station Fryer
	200-2295		Three-Station Fryer
	200-2725		Four-Station Fryer
	200-3592		Five-Station Fryer
9	200-4422		Support, Contactor Box Right Station 3 or Station 5
10	201-4425		Support, Contactor Box Left Station 4 or Station 5
11	202-4425		Support, Contactor Box Right Station 3
12	200-4423		Support, Contactor Box Stations 3 and 4
13	200-4447		Support, Contactor Box Front to Rear
14	201-5369		Support, Contactor Box Station 2
15	202-5369		Support, Contactor Box Station 1
16	200-4424		Post, Door
17	810-2346		Magnet, Door
18	200-4786		Support, Oil Return Manifold
19	210-5595		Hinge, Door
20	210-1490		Bracket, Rear Support
21	900-1224		Bracket, Frypot
22	809-0131		Bolt, 1/4-20 X 3/4-inch Hex Head (<i>also used w/Item 27 to mount filter rails</i>)
23	826-1371		Screw, #8 X 1/2-inch Drill Point Hex Head (Pkg. of 25)
24	826-1330		Screw, 10-32 X 3/8-inch Slotted (Pkg. of 25, used to attach contactor box)
25	809-0256		Nut, 10-32 Keps Hex
26	809-0412		Screw, #10 X 1/2-inch Hex Washer Head (<i>primary cabinet screw</i>)
27	809-0417		Nut, 1/4-20 Hex Flange
28	809-0429		Bolt, 1/4-20 X 2-inch Hex Head
29	200-5417		Brace, Rear Channel Corner
30			Channel, Base Rear
	200-5463		Two-Station Fryer
	200-5538		Three-Station Fryer
	200-5537		Four-Station Fryer
	200-5536		Five-Station Fryer
31	824-1131		Channel, Base Side
32	810-0326		Caster with Brake
33	810-1494		Caster without Brake
*	810-1234		Leg, Stainless Steel 8.5-inch Adjustable (<i>mounts with Items 27 and 28</i>)
*	823-4386		Leg, Navy Shipboard (<i>mounts with Items 27 and 28</i>)

* Not Illustrated.

■ Use standard part.

2.4 Drain System Components

2.4.1 Drain Tube Sections and Associated Parts

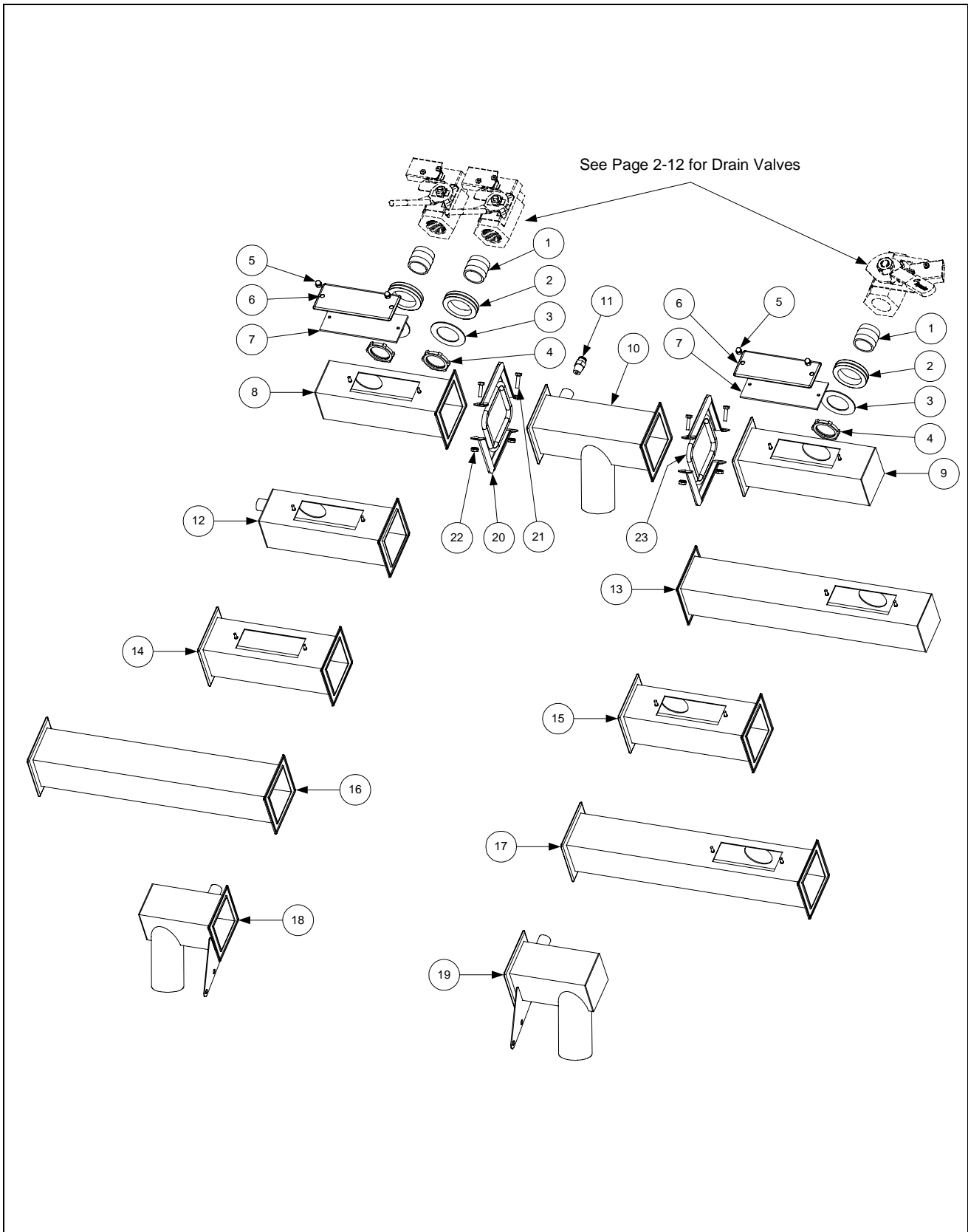

ITEM	STANDARD PART # **	COMPONENT
1	813-0284	Nipple, ¾ X 1-inch NPT
2	816-0092	Grommet, 1-inch Drain
3	826-1345	Washer, 1-inch Drain (Pkg. of 25)
4	809-0347	Nut, 1-inch NPT Retainer
5	809-0893	Nut, 8-32 High Crown Acorn
6	826-1348	Cover, Drain Cleanout (Pkg. of 5)
7	816-0021	Gasket, Drain Cleanout
8		Drain Tube, Left End Short
	823-3380	Full-Vat
	823-3379	Dual-Vat
9		Drain Tube, Right End Short
	823-1551	Full-Vat
	823-1549	Dual-Vat
10		Drain Outlet
	823-3229	With Vacuum Breaker Vent
	823-2336	Without Vacuum Breaker Vent
11	810-2492	Fitting, Quick-Connect Straight (receives Teflon vent tube)
12		Drain Tube, Left End Short Vented
	823-2637	Full-Vat
	823-2636	Dual-Vat
13		Drain Tube, Right End Long
	823-1508	Full-Vat
	823-1543	Dual-Vat
14	823-3675	Drain Tube, Spreader Cabinet Short
15		Drain Tube, Open End Short
	823-0718	Full-Vat
	823-0725	Dual-Vat
16	823-0731	Drain Tube, Spreader Cabinet Long
17		Drain Tube, Open End Long
	823-0717	Full-Vat
	823-0724	Dual-Vat
18	823-3674	Drain Outlet, Filter Magic Left
19	823-3673	Drain Outlet, Filter Magic Right
20	810-0396	Clamp
21	809-0401	Screw, 10-32 X ¾-inch Hex Head
22	809-0256	Nut, 10-32 Keps Hex
23	816-0032	Gasket
*	826-0877	Kit, Square Drain Clamp (2 each of Items 20-22 and 1 of Item 23)
*	811-1071	Tube, Teflon Vent

* Not illustrated.

** See page 2-11 for an *Euro-Look* parts list.

2.4.2 Euro-Look Drain Tube Section and Associated Parts

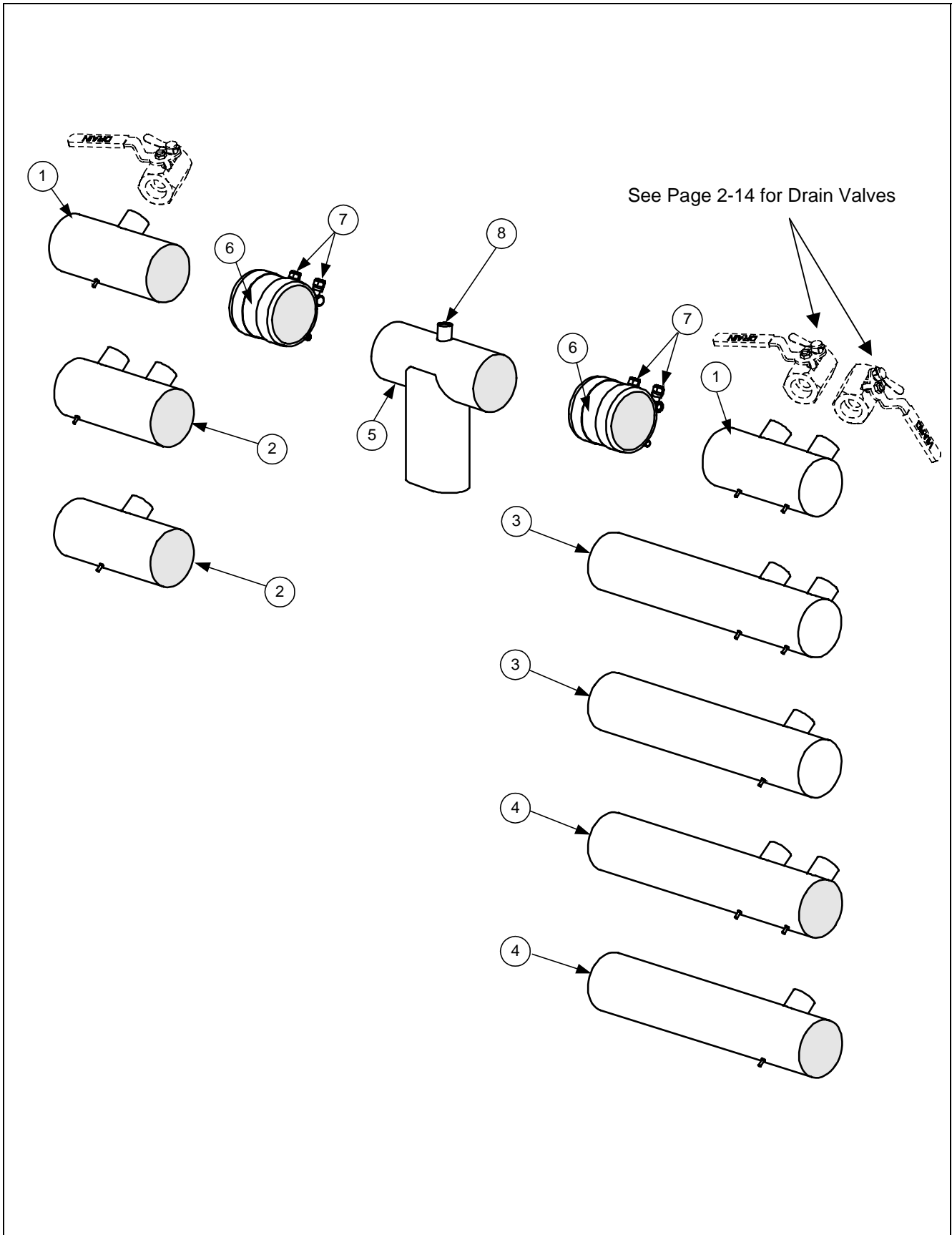

ITEM	EURO-LOOK PART# **	COMPONENT
1		Drain Tube, Left/Right End Short
	823-4625	Full-Vat
	823-4624	Dual-Vat
2		Drain Tube, Left/Right Open Short
	823-4643	Full-Vat
	823-4642	Dual-Vat
3		Drain Tube, Right End Long
	823-4639	Full-Vat
	823-4638	Dual-Vat
4		Drain Tube, Left/Right Open Long
	823-4641	Full-Vat
	823-4640	Dual-Vat
5	823-4892	Drain Outlet
6	816-0625	Sleeve
7	809-0969	Clamp
8	810-2492	Fitting, Quick-Connect Straight (receives Teflon vent tube)
*	KIT6033	Kit, Round Drain Clamp (2 or Item 7 and 1 of Item 6)
*	811-1071	Tube, Teflon Vent

* Not illustrated.

** See page 2-9 for a standard parts list.

2.4.3 Drain Valves and Associated Parts (Units with Built-In Filtration)

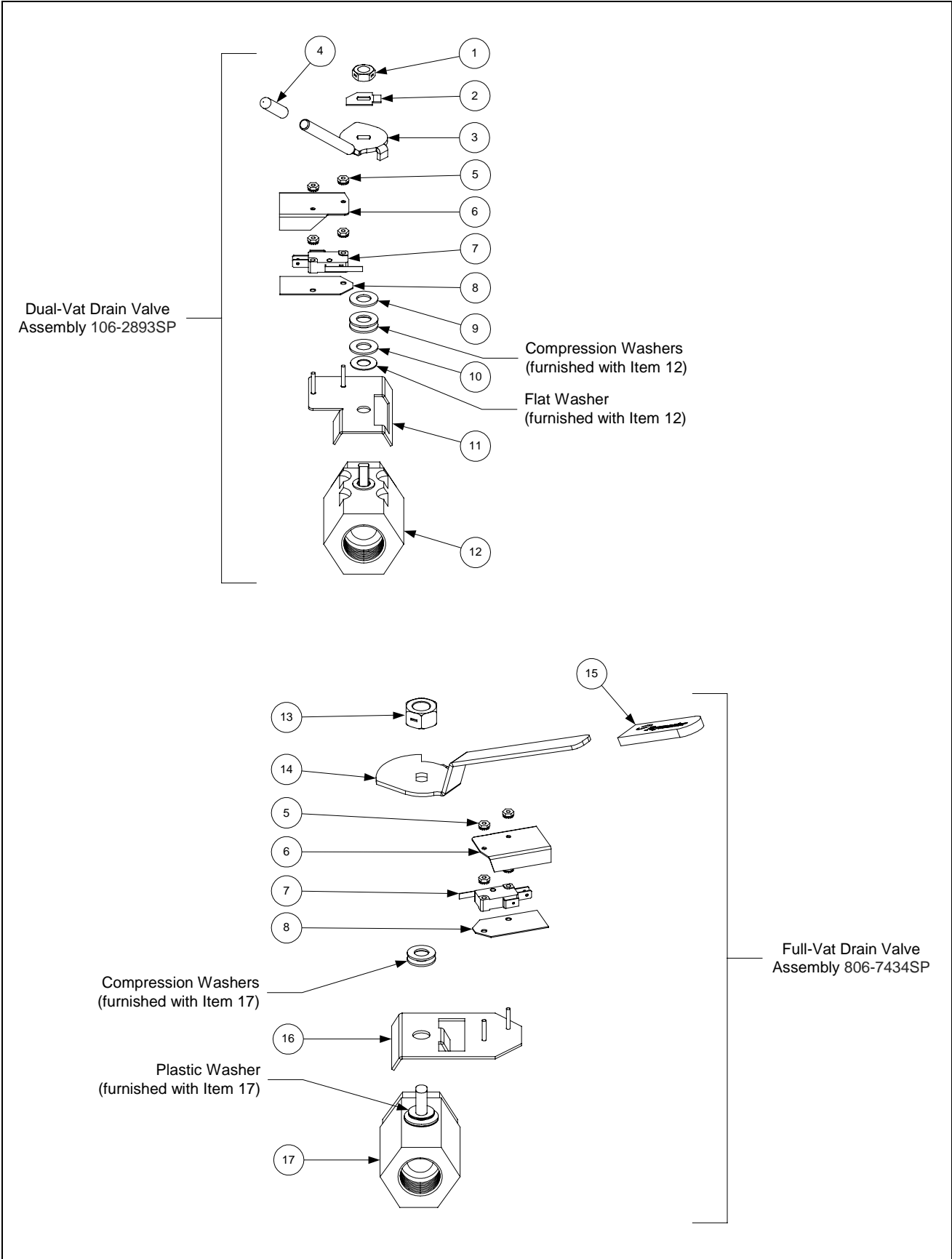

ITEM	STANDARD PART # **	COMPONENT
1	809-0539	Nut, 3/8-16 2-Way Hex Lock
2	900-2934	Retainer, Dual-Vat Drain Valve Nut
3	823-4133	Handle, Dual-Vat Drain Valve
4	810-0677	Grip, Drain Handle
5	809-0237	Nut, 4-40 Keps Hex
6	901-2348	Cover, Dual Vat Drain Safety Switch
7	807-2103	Microswitch, CE Straight Lever
8	816-0220	Insulation, Drain Safety Switch
9	810-1165	Washer, Teflon Drain Valve
10	809-0196	Washer, 3/8-inch Flat
11	106-2671SP	Bracket Assembly, Dual-Vat Drain Safety Switch
12	810-1338	Valve, 1-inch Dual-Vat Drain
13	809-0540	Nut, 1/2-13 2-Way Hex Lock
14	900-2609	Handle, Full-Vat Drain Valve
15	814-0047	Sleeve, Red Handle
16	806-8137SP	Bracket Assembly, Full-Vat Drain Safety Switch
17	810-1020	Valve, 1.25-inch Full-Vat Drain
*	WIR0572	Wire Bundle, Drain Safety Switch

* Not illustrated.

** See page 2-15 for a *Euro-Look* parts list.

2.4.4 Euro-Look Drain Valves and Associated Parts (Units with Built-In Filtration)

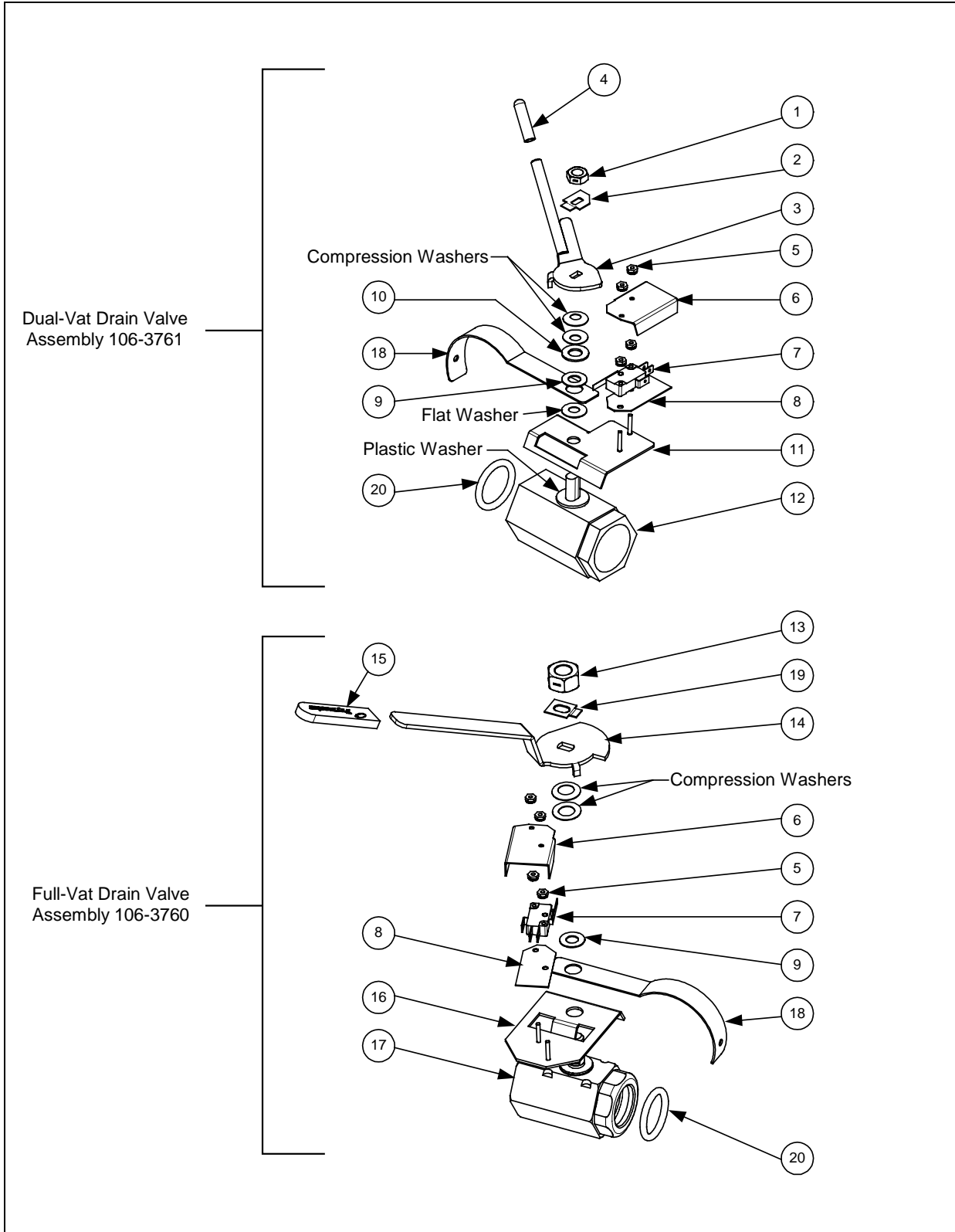

ITEM	EURO-LOOK PART #**	COMPONENT
1	809-0539	Nut, 3/8-16 2-Way Hex Lock
2	900-2934	Retainer, Dual-Vat Drain Valve Nut
3	823-4133	Handle, Dual-Vat Drain Valve
4	810-0677	Grip, Drain Handle
5	809-0237	Nut, 4-40 Keps Hex
6	901-2348	Cover, Dual Vat Drain Safety Switch
7	807-2103	Microswitch, CE Straight Lever
8	816-0220	Insulation, Drain Safety Switch
9	810-1165	Washer, Teflon Drain Valve
10	809-0196	Washer, 3/8-inch Flat
11	106-2671	Bracket Assembly, Dual-Vat Drain Safety Switch
12	810-1114	Valve, 1-inch Dual-Vat Drain
13	809-0540	Nut, 1/2-13 2-Way Hex Lock
14	900-2609	Handle, Full-Vat Drain Valve
15	814-0047	Sleeve, Red Handle
16	806-8137	Bracket Assembly, Full-Vat Drain Safety Switch
17	810-1018	Valve, 1.25-inch Full-Vat Drain
18	200-6496	Support, 3" Drain
19	900-2936	Retainer, Full-Vat Drain Valve Nut
20	816-0135	Round Drain O-Ring
*	WIR0572	Wire Bundle, Drain Safety Switch

* Not illustrated.

** See page 2-13 for a standard parts list.

2.4.5 Drain Valves and Associated Parts (Units without Built-In Filtration)

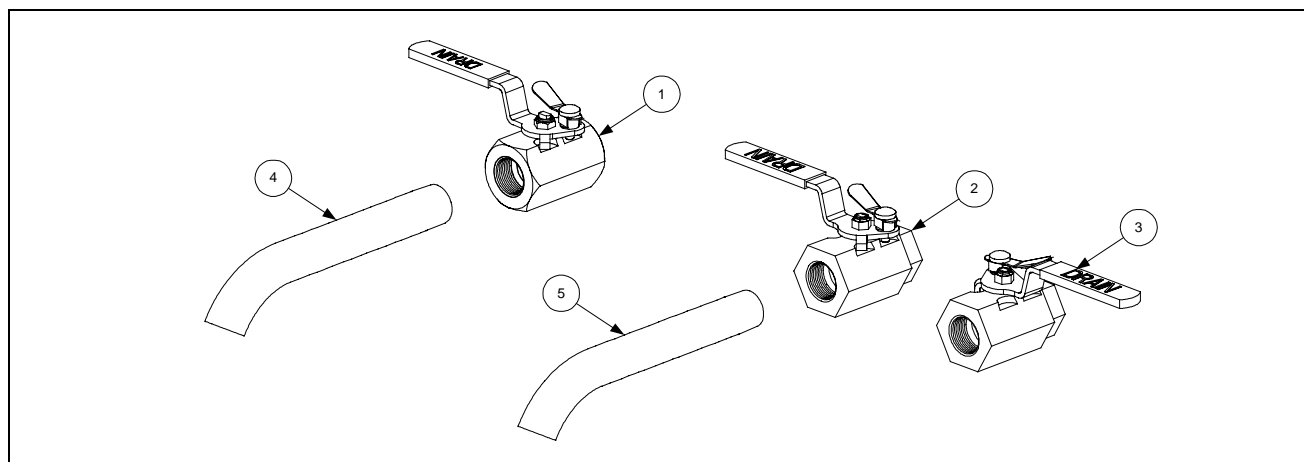

ITEM	STANDARD PART #	EURO-LOOK PART #	COMPONENT
1	810-1569		Valve, 1.25-inch Non-Filter Full-Vat Drain
2	806-7915SP		Valve, 1-inch Non-Filter Dual-Vat Left Drain
3	806-7916SP		Valve, 1-inch Non-Filter Dual-Vat Right Drain
4	812-1226		Drain Extension, 1.25-inch
5	812-1227		Drain Extension, 1-inch

Use standard part.

2.5 Electronics and Wiring Components

2.5.1 Component Boxes

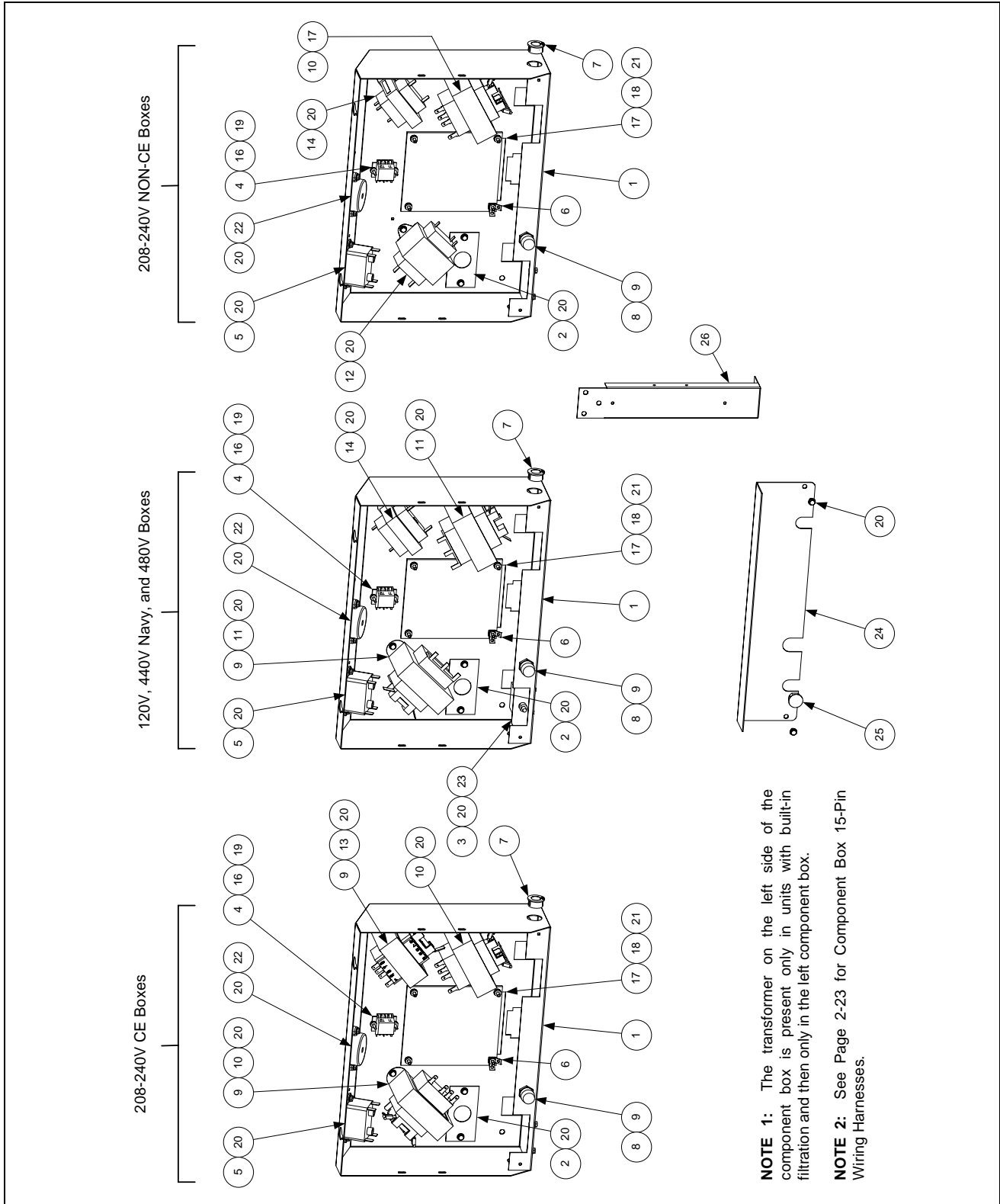

ITEM	STANDARD PART #	EURO-LOOK PART #	COMPONENT
1	106-1531SP		Box Assembly, Component
2	200-3300		Bracket, Component Box Strain Relief
3	200-3746		Bracket, Navy Circuit Breaker (US Navy units only)
4	806-9495SP		Terminal Block and Wire Assembly
5	807-0012		Relay, 18 Amp 1/3 HP 24V Coil
6	807-0037		Terminal, 1/4-inch Push-on
7	807-0121		Bushing, Heyco Plastic AB-625-500
8	807-1321		Holder, AGC Panel-Mount 1/4-inch Fuse
9	807-1597		Fuse, 3 Amp Slow-Blow
10	807-2180		Transformer, 208-240V 50VA
11	807-2181		Transformer, 100-120V/24V 60VA
12	807-0680		Transformer, 208-240V/24V 20VA
13	807-2191		Transformer, 208-240V/12V 30VA
14	807-0855		Transformer, 100-120V/12V 20VA
15	807-0979		Transformer, 208-240V/12V 43VA
16	826-1366		Nut, 4-40 Keps Hex (Pkg. of 25)
17	809-0250		Nut, 6-32 Keps Hex
18	809-0349		Spacer, 4mm X 6mm Aluminum
19	826-1359		Screw, 4-40 X 3/4-inch Slotted Round Head (Pkg. of 25)
20	809-0359		Screw, #8 X 1/4-inch Hex Washer Head
21			Interface Board
	806-6336SP		Standard (Non-Triac), Full- or Dual-Vat
	806-6347SP		Triac, Full- or Dual-Vat
	106-3721		Fast Computer, Full- or Dual-Vat
*	807-3932		Relay, Heat and Latch 12 VDC SPDT 12A
22	806-7179SP		Sound Device
23	807-0069		Circuit Breaker, 10 Amp
24	200-3844		Guard, Finger
25	810-2445		Plug Button
26	200-3243		Brace, Component Box

* Not illustrated.

■ Use standard part.

2.5.2 Contactor Boxes

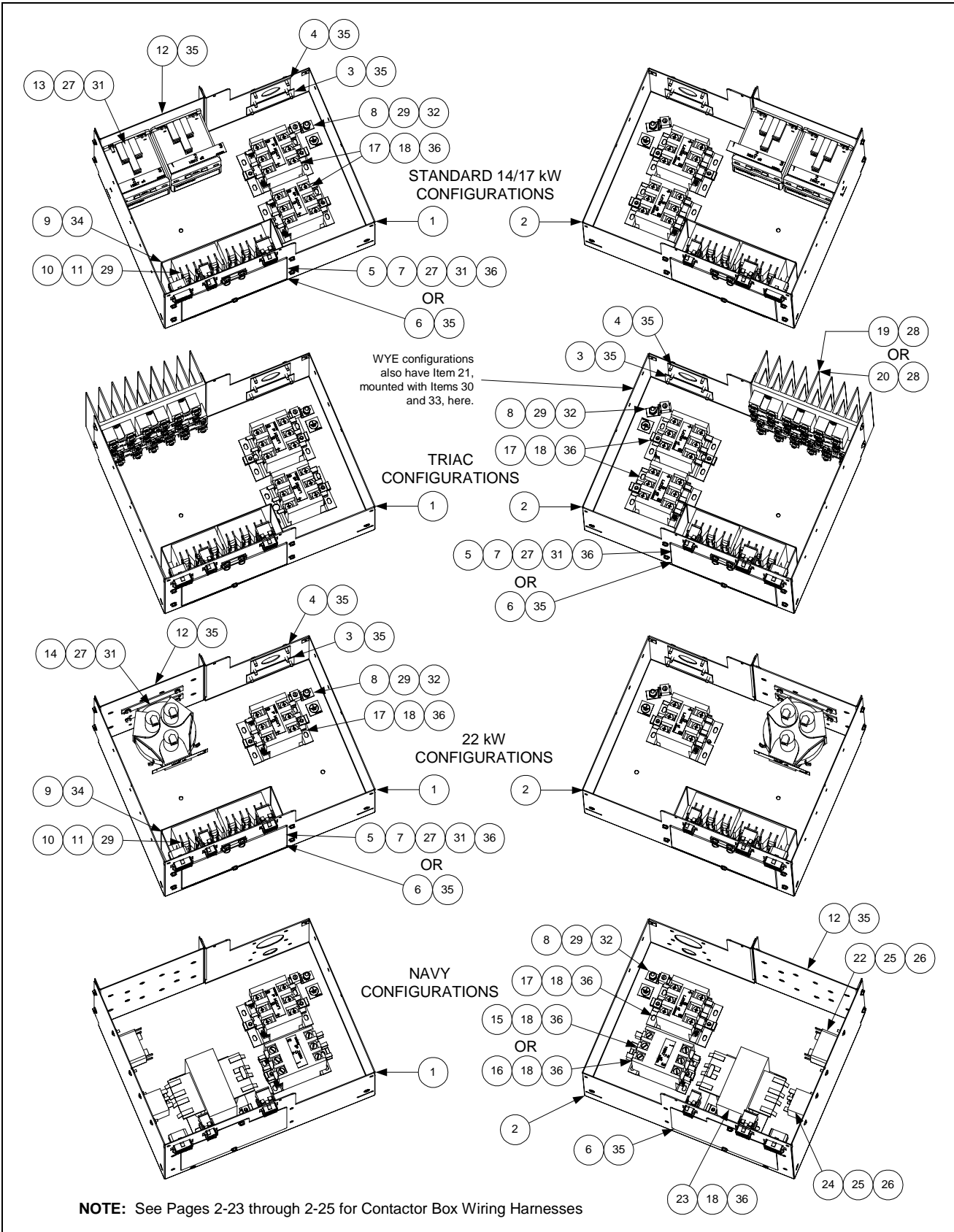

NOTES: Left and right contactor box assemblies are mirror images of one another. With the exception of the box itself, all components of a left-hand assembly are the same as those in the corresponding right-hand assembly and vice versa. The configurations illustrated show all possible components, but a particular configuration may not have all the components shown.

ITEM	STANDARD PART #	EURO-LOOK PART #	COMPONENT
1	106-1536SP		Box Assembly, Left Contactor
2	106-1537SP		Box Assembly, Right Contactor
3	200-3111		Cover, Cord Cutout
4	900-2752		Plate, Cordset Adapter
5	200-2334		Door, Contactor Box Hinged
6	200-4712		Door, Contactor Box w/o Hinge
7	810-0519		Hinge, Contactor Box Door
8	807-0070		Terminal, Ground Lug
9	200-2336		Bracket, Contactor Box Fuse Block
10	807-0501		Fuse Block, 3-Pole
11	807-2240		Fuse, 60 Amp 300VAC
12	200-2337		Bracket, Mercury Contactor
13	807-1071		Contactor, 24V 30 Amp Mercury
14	807-0884		Contactor, 24V 35-50 Amp Mercury
15	807-2284		Contactor, 24V 50 Amp Mechanical (<i>only in 14 & 17kW Navy units</i>)
16	807-2283		Contactor, 24V 63 Amp Mechanical (<i>only in 22kW Navy units</i>)
17	810-1202		Contactor, 24V 40 Amp 3-Pole
18	809-0448		Clip, Tinnerman
19**	806-8674		Heatsink Assembly, DV Solid State Relay (See components below)
20**	806-8673		Heatsink Assembly, FV Solid State Relay (See components below)
21	806-9124		Filter Assembly, Triac (<i>used in Wye-configured Triac units only</i>)
22	807-0012		Relay, 18 Amp □ HP 24V Coil
23	807-0064		Transformer, 480V/120V 150VA
24	807-1683		Relay, 12VDC
25	826-1358		Nut, 6-32 Keps Hex (Pkg. of 25)
26	826-1365		Screw, 6-32 X 3/8-inch Slot Head (Pkg. of 25)
27	809-0104		Screw, 8-32 X 1/2-inch Slot Head
28	826-1330		Screw, 10-32 X 3/8-inch Slot Head (Pkg. of 25)
29	809-0123		Screw, #10 X 3/4-inch Slot Head
30	826-1366		Nut, 4-40 Keps Hex (Pkg. of 25)
31	809-0247		Nut, 8-32 Keps Hex
32	826-1376		Nut, 10-32 Keps Hex (Pkg. of 10)
33	826-1359		Screw, 4-40 X 3/4-inch Slot Head (Pkg. of 25)
34	809-0359		Screw, #8 X 1/4-inch Hex Washer Slot Head
35	809-0360		Screw, #8 X 3/8-inch Hex Washer Slot Head
36	826-1374		Screw, #10 X 1/2-inch Hex Head (Pkg. of 25)
*	200-5627		Lid, Left or Right Contactor Box
*			Components of Items 19 and 20
**	826-1562		Relay, Solid State 50 Amp 280V
*	807-2749		Heatsink, Solid State
*	807-0037		Terminal, 1/4-inch Push-on
*	809-0096		Screw, 6-32 X 5/8-inch Slot Head

* Not illustrated.

■ Use standard part.

** Dual-vat Assembly has six relays (826-1562); full-vat Assembly has three relays.

2.5.3 Heating Element Assemblies and Associated Parts

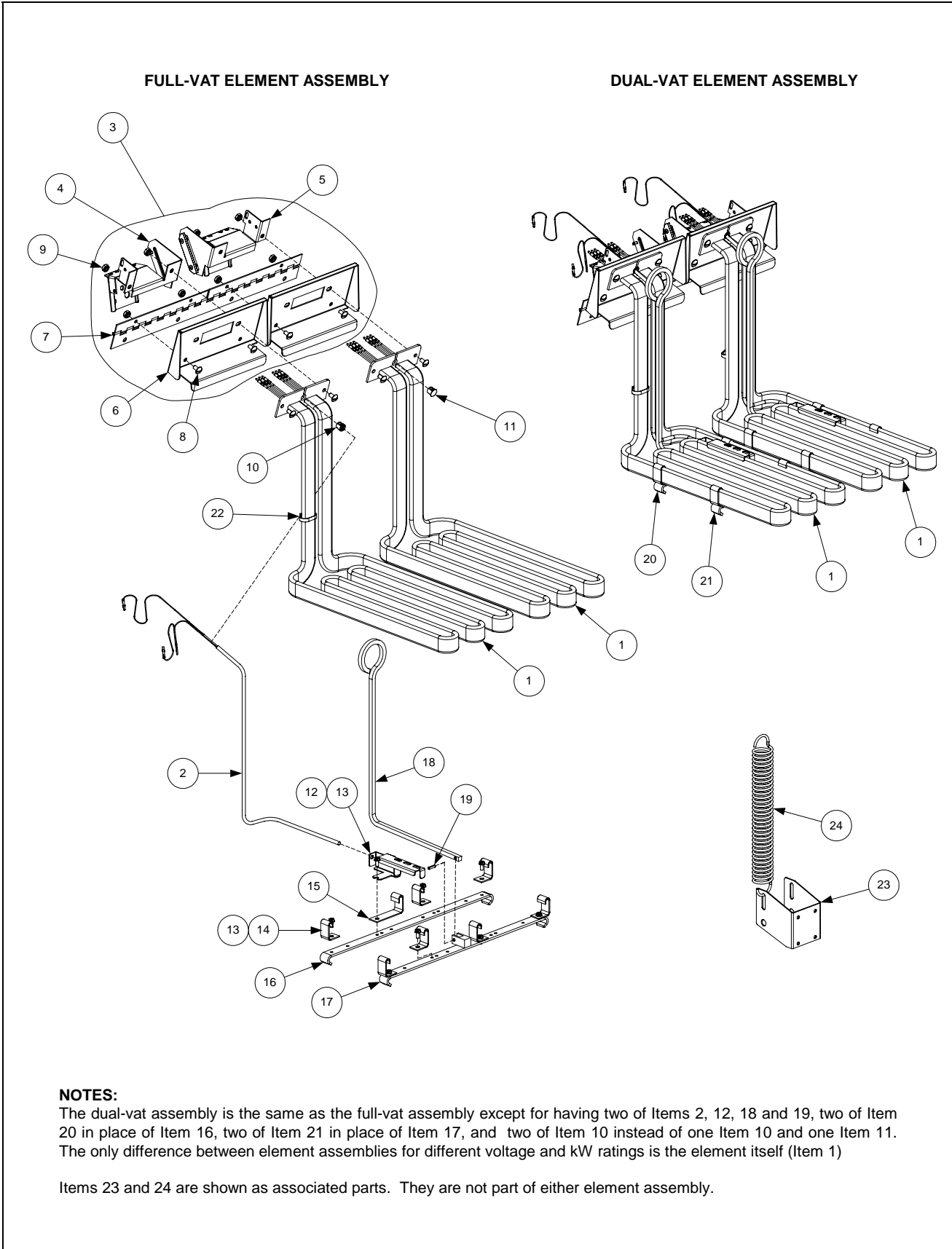

ITEM	STANDARD PART #	EURO-LOOK PART #	COMPONENT
1			Element
	826-2151		200V 7.0 kW (also used for 220V 8.5 kW)
	826-2156		200V 8.5 kW
	826-2167		200V 11.0 kW
	826-2149		208V 7.0 kW
	826-2150		208V 8.5 kW
	826-2172		208V 11.0 kW
	826-2155		220V 7.0 kW (also used for 240V 8.5 kW)
	826-2151		220V 8.5 kW (also used for 200V 7.0 kW)
	826-2164		220V 11.0 kW
	826-2152		230V 7.0 kW
	826-2153		230V 8.5 kW
	826-2165		230V 11.0 kW
	826-2154		240V 7.0 kW
	826-2155		240V 8.5 kW (also used for 220V 7.0 kW)
	826-2166		240V 11.0 kW
	826-2157		380V 7.0 kW
	826-2158		380V 8.5 kW
	826-2168		380V 11.0 kW
	826-2159		440V 7.0 kW
	826-2160		440V 8.5 kW
	826-2169		440V 11.0 kW
	826-2161		480V 7.0 kW
	826-2162		480V 8.5 kW
	826-2170		480V 11.0 kW
2	826-1526		Probe, Temperature
3	106-0004SP		Tilt Plate Assembly
4	106-0572SP		Bracket, Left Spring Slot
5	106-0573SP		Bracket, Right Spring Slot
6	910-9641		Tilt Plate
7	810-0035		Hinge
8	826-1330		Screw, 10-32 X 3/8-inch Slotted Truss Head (Pkg. of 25)
9	826-1376		Nut, 10-32 Keps Hex (Pkg. of 10)
10	826-1339		Bushing, .375-inch Split (Pkg. of 10)
11	816-0480		Plug, .375-inch Dome
12	910-5022		Bracket, Temperature Probe
13	809-0518		Screw, 8-32 X 3/8-inch Slotted Hex Head
14	910-2042		Clamp, Element (Short)
15	910-5213		Clamp, Element (Long)
16	910-3681		Support, Full-Vat Element Rear
17	823-2377		Support, Full-Vat Element Front
18	810-1233		Handle, Element Lift
19	810-1212		Pin, .125 X .5-inch Split
20	910-5214		Support, Dual-Vat Element Rear
21	823-2378		Support, Dual-Vat Element Front
22	809-0567		Tie-Wrap, Metal
23	200-2060		Bracket, Lower Spring Slot
24	810-0297		Spring, Element
*	826-1061		Tilt Switch, Mercury Non-CE (Full-Vat requires one switch and Dual-Vat requires two.)
*	826-2228		Magnetic Tilt Switch CE (Full-Vat requires one switch and Dual-Vat requires two.)

* Not illustrated.

Use standard part.

2.5.4 Controllers

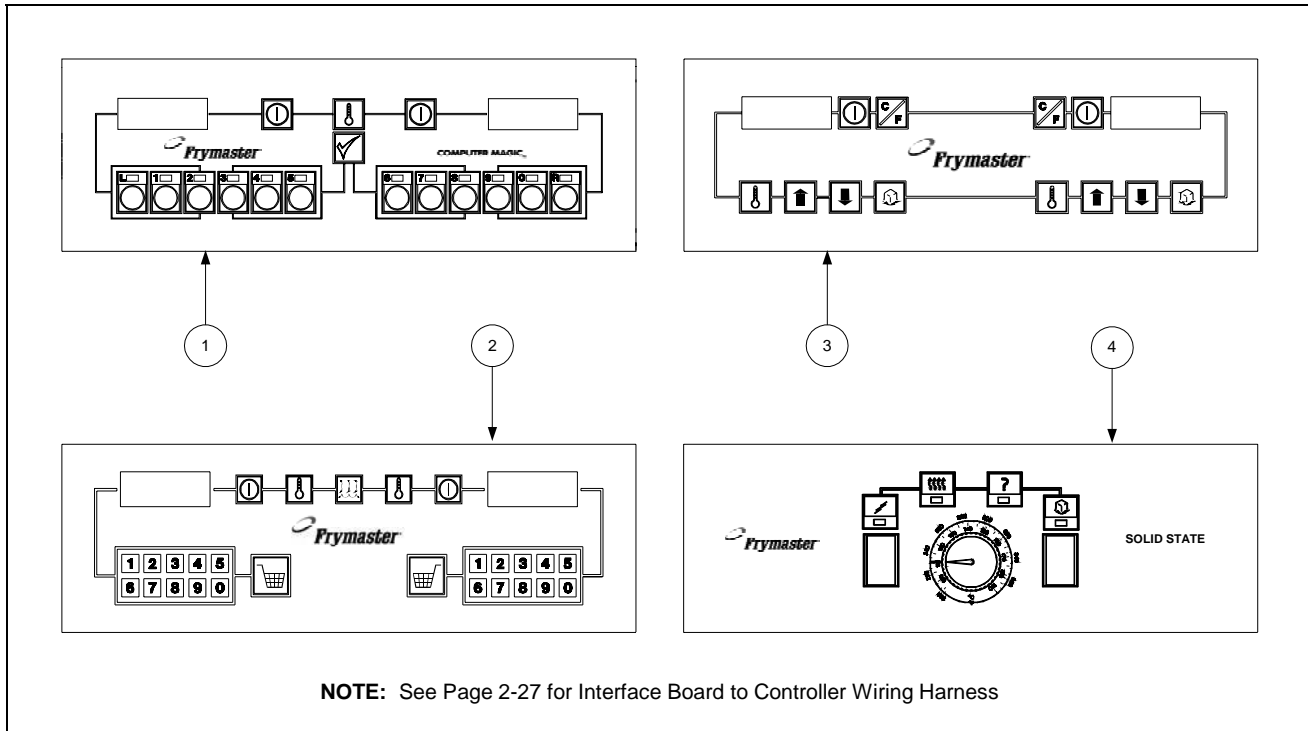

ITEM	STANDARD PART #	EURO-LOOK PART #	COMPONENT
1			Computer Magic III
	106-1193	106-4335	Full-Vat (CE)
	106-1194	106-4336	Dual-Vat (CE)
	806-7158SP	106-4373	Full-Vat (Non-CE)
	806-7159SP	106-4374	Dual-Vat (Non-CE)
	806-7162SP	106-4337	Full-Vat (Triac/Solid State)
	806-7163SP	106-4338	Dual-Vat (Triac/Solid State)
2			Digital Controller
	106-1507	106-4343	Full-Vat (CE)
	106-1508	106-4344	Dual-Vat (CE)
	106-1503	106-4339	Full-Vat (Non-CE)
	106-1504	106-4340	Dual-Vat (Non-CE)
3			Basket Lift Timer
	106-2090SP	106-4365	Full-Vat (CE)
	106-2091SP	106-4366	Dual-Vat (CE)
	106-2088SP	106-4363	Full-Vat (Non-CE)
	106-2089SP	106-4364	Dual-Vat (Non-CE)
4			Solid-State (Analog) Controller
	806-7422	106-4333	Full-Vat
	806-7423	106-4334	Dual-Vat

2.5.5 Wiring

2.5.5.1 Contactor Box Wiring Assemblies – 12-Pin Dual-Vat C-1

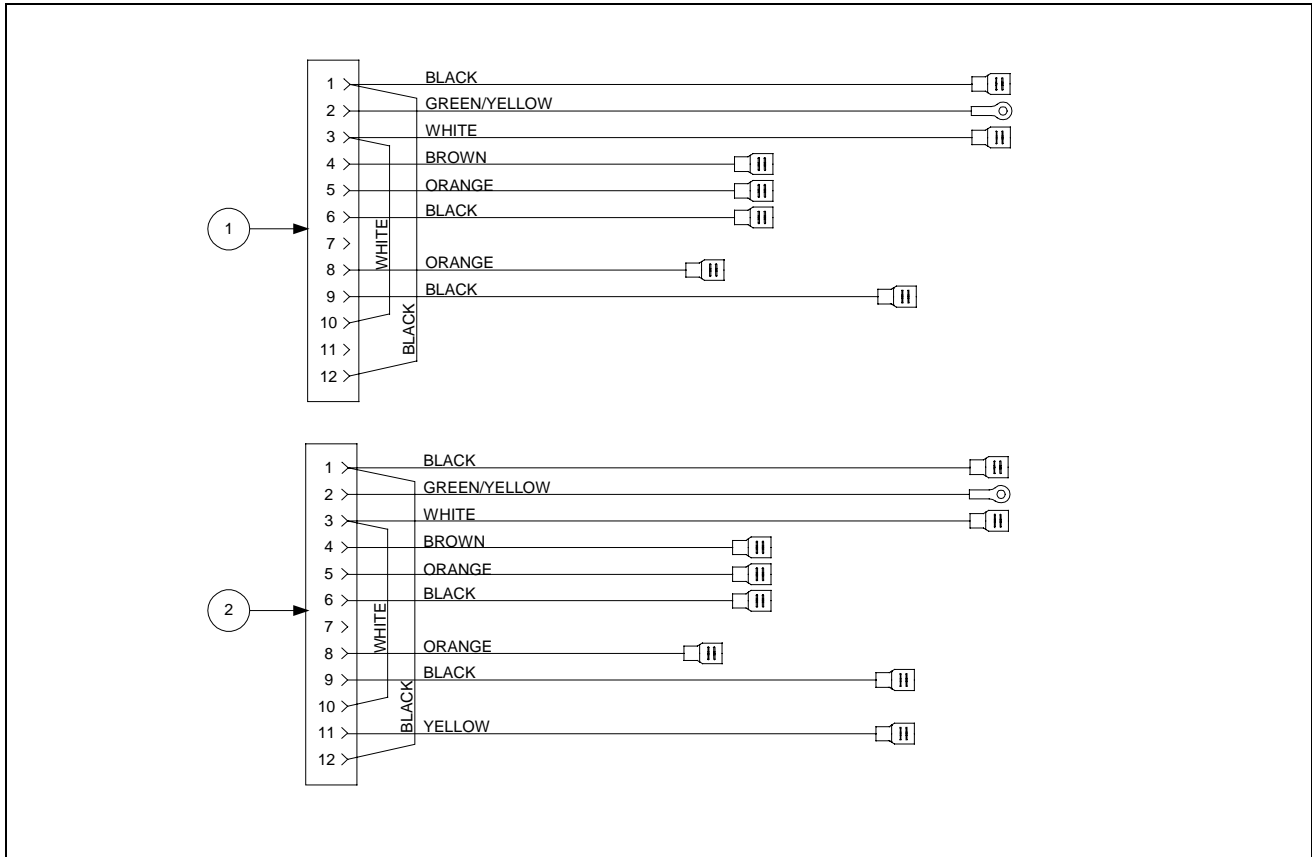

ITEM	STANDARD PART #	EURO-LOOK PART #	COMPONENT
1	106-2428SP		Standard
2	106-2343SP		Triac

■ Use standard part.

2.5.5.2 Contactor Box Wiring Assemblies – 12-Pin Full-Vat C-1

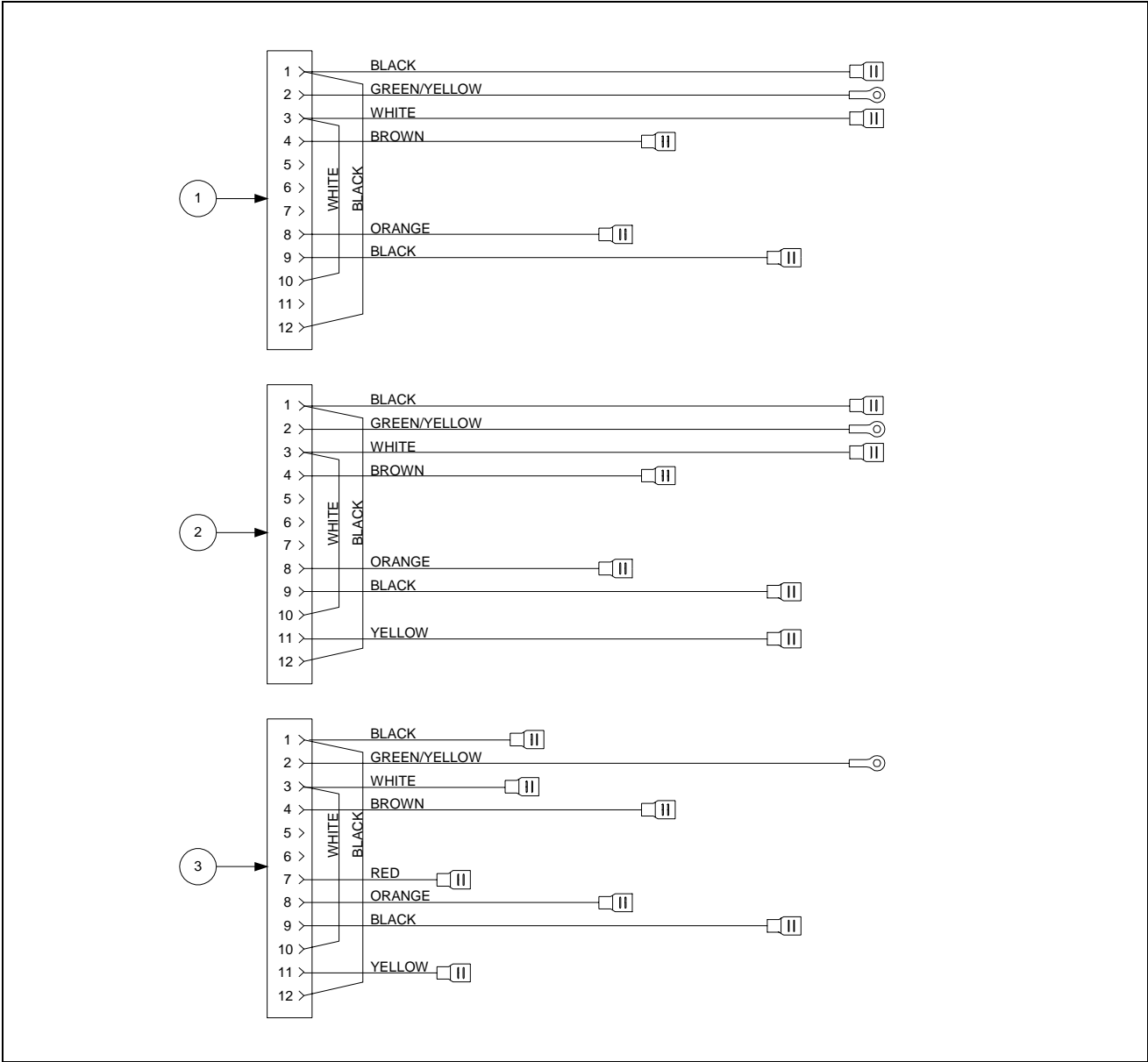

ITEM	STANDARD PART #	EURO-LOOK PART #	COMPONENT
1	106-2474SP		Standard
	106-2522SP		Other than 480V
2	106-2475SP		Triac
3	106-2477SP		Navy

■ Use standard part.

2.5.5.3 Contactor Box Wiring Assemblies – 6-Pin (Left Element)

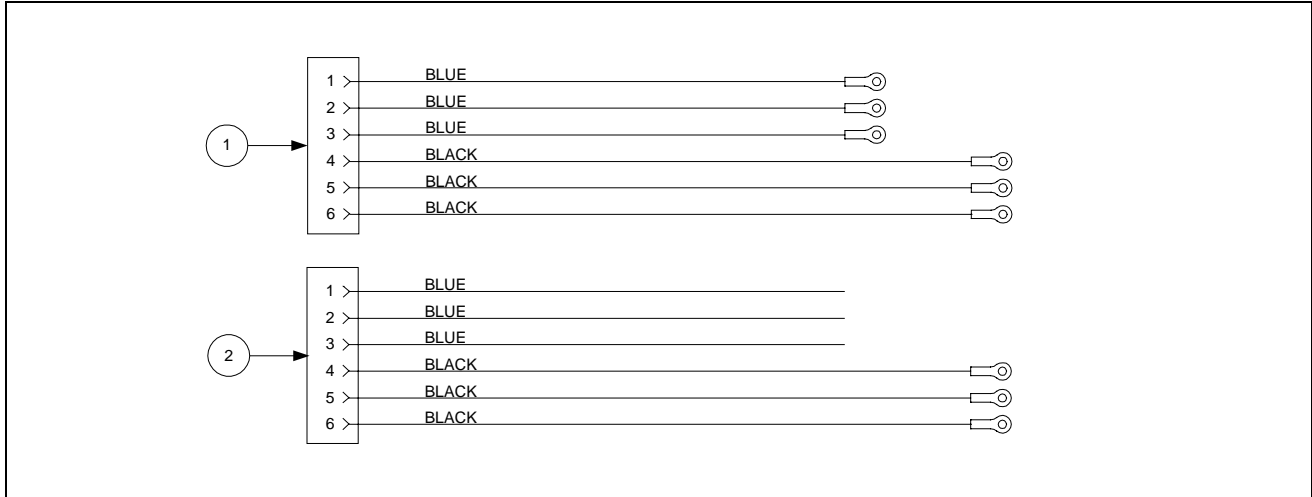

ITEM	STANDARD PART #	EURO-LOOK PART #	COMPONENT
1	106-2426SP		14/17 kW
2	106-2473SP		22 kW and Navy

Use standard part.

2.5.5.4 Contactor Box Wiring Assemblies – 9-Pin (Right Element)

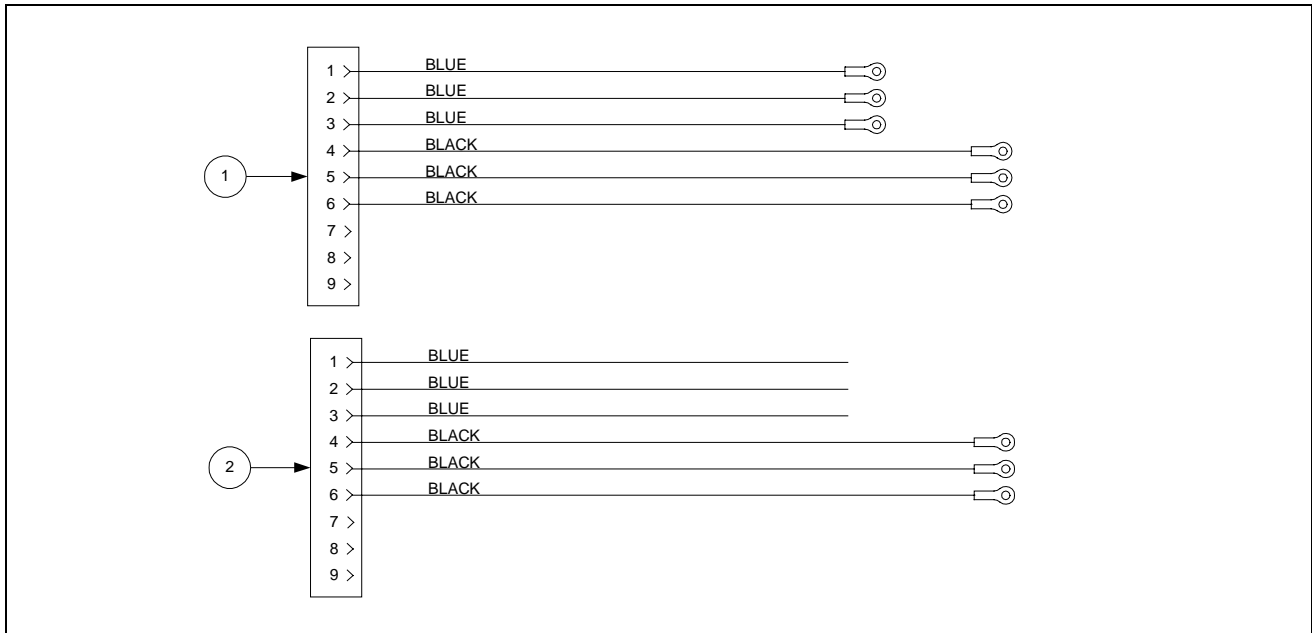

ITEM	STANDARD PART #	EURO-LOOK PART #	COMPONENT
1	106-2425SP		14/17 kW
2	106-2472SP		22 kW and Navy

Use standard part.

2.5.5.5 Main and Multi-Fryer Wiring Harnesses

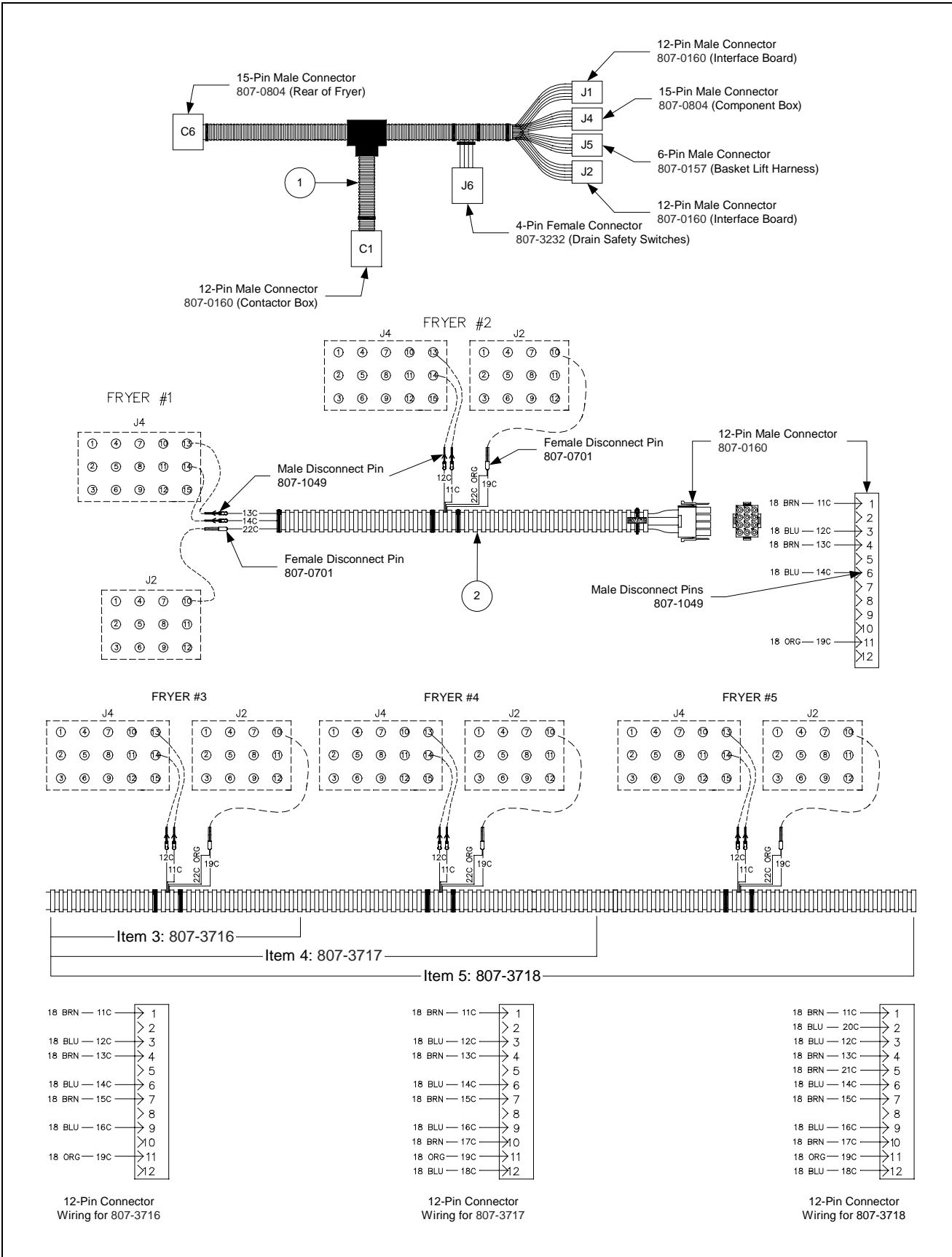

ITEM	STANDARD PART #	EURO-LOOK PART #	COMPONENT
1	807-3769		Main
2	807-3715		Two-Fryer Battery
3	807-3716		Three-Fryer Battery
4	807-3717		Four-Fryer Battery
5	807-3718		Five-Fryer Battery

NOTE: Harnesses for 3-, 4-, and 5-Fryer batteries are similar to 807-3715 but have extra sets of leads as appropriate for the number of fryers in the battery. The connections to Fryer #1 J2 and J4 are the same for all. Use standard part.

2.5.5.6 Component Box Wiring Harnesses – 15-Pin

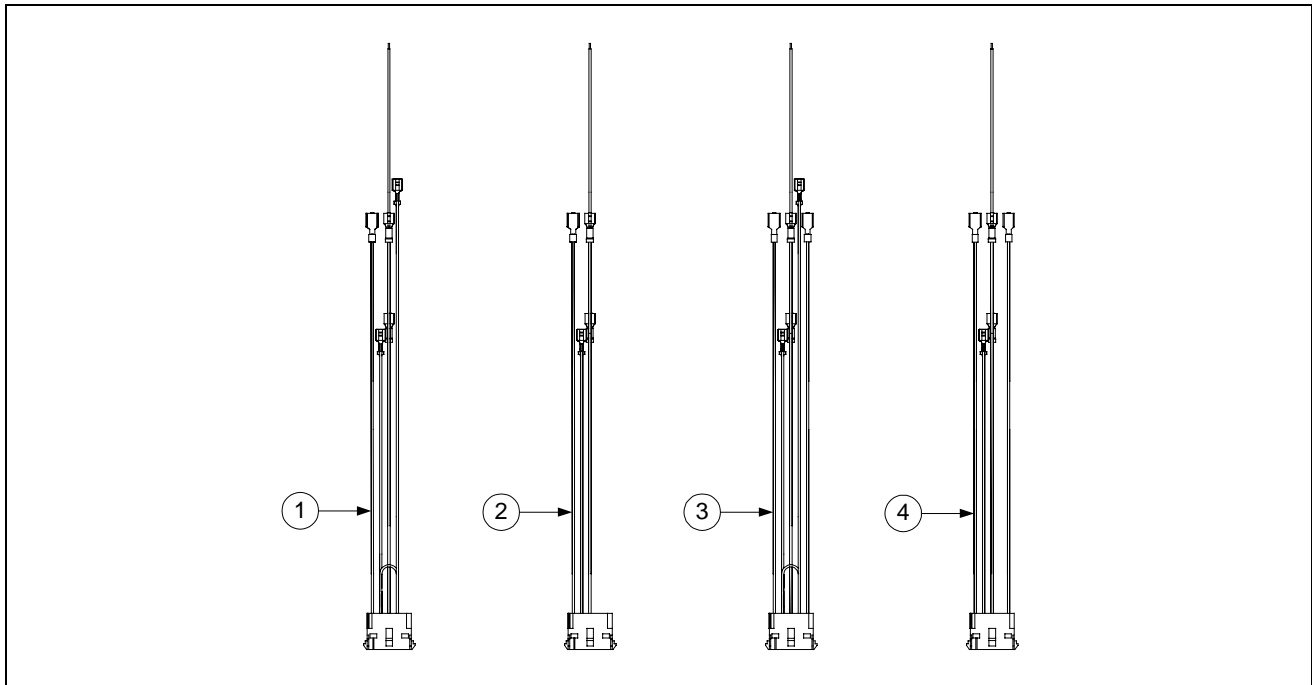

ITEM	STANDARD PART #	EURO-LOOK PART #	COMPONENT
1	106-2506SP		208-480V (With Filter)
2	106-2507SP		208-480V (Without Filter)
3	106-2508SP		120V (With Filter)
4	106-2509SP		120V (Without Filter)

Use standard part.

2.5.5.7 Interface Board to Controller Wiring Harness – 15-Pin

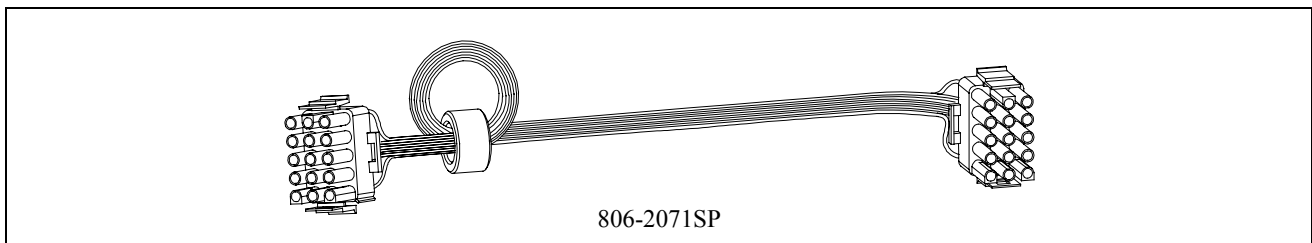

2.6 Filtration System Components

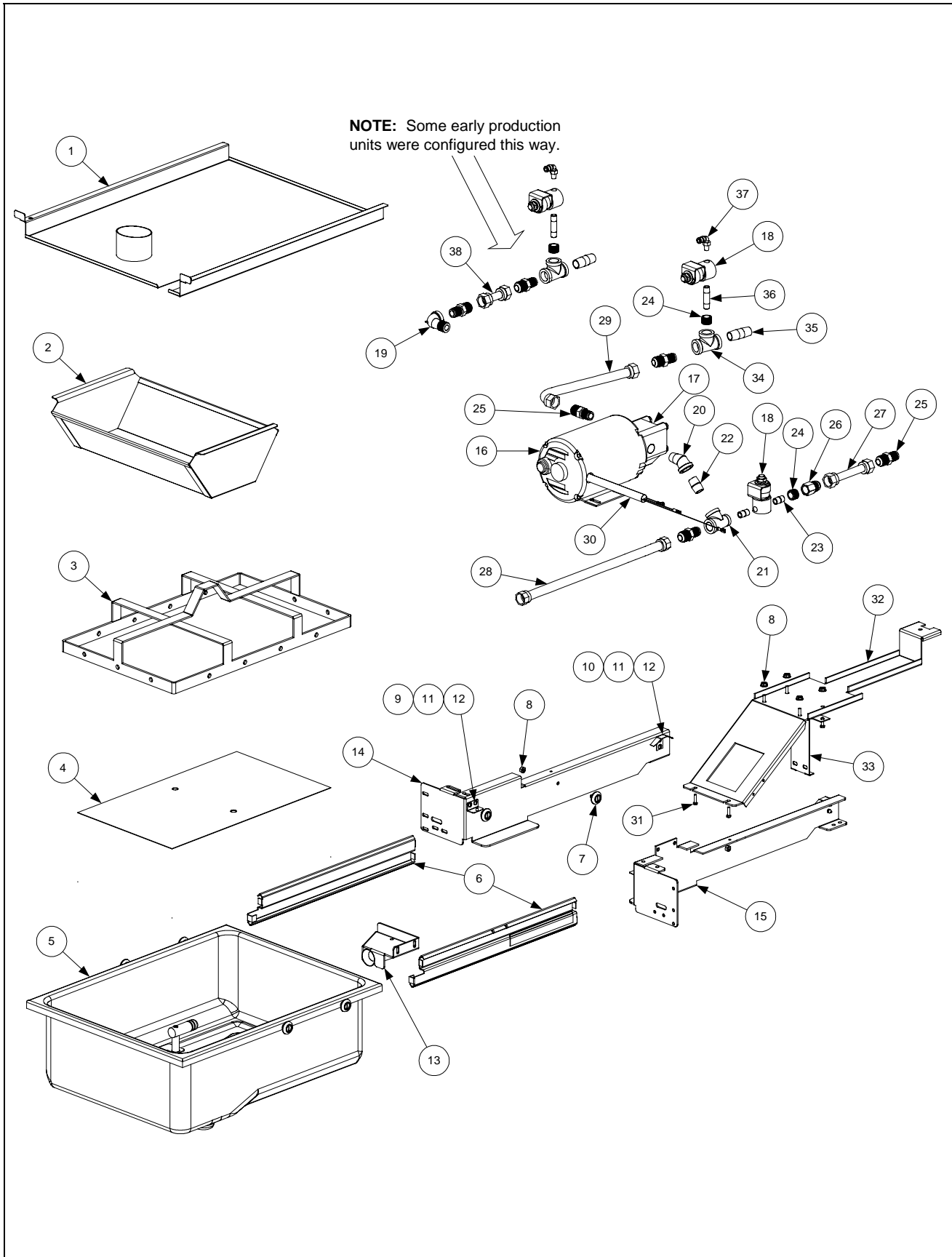

ITEM	STANDARD PART #	EURO-LOOK PART #	COMPONENT
*	826-1979		Filter Pan Roller Kit (four each of Items 7 and 8)
*	826-1980		Service Filter Pan (Item 5 minus Item 2)
*	826-1981		Service Filter Pan Assembly (Service Filter Pan above plus Items 3 and 4)
*	826-1392	816-0012	O-Ring (Pkg. of 5; used with Item 5)
*	813-0568		Plug, 1/8-inch Socket Head Pipe (component of Item 5; two required)
*	811-1071		Tubing, 1/4-inch OD Teflon Vent (sold by the foot)
*	106-2851SP		Heater Strip Assembly, 100-120V
*	106-2852SP		Heater Strip Assembly, 208-250V
1	823-4637	823-4787	Lid (<i>for units built before Feb 2004, use 823-4391</i>)
2	810-2874		Crumb Tray (component of Item 5)
3	810-2091		Hold-Down Ring (<i>two are needed for pad hold-down option</i>)
4	200-2124		SanaGrid Filter Screen
5	106-2617SP		Pan, One-Piece Filter (includes Item 2)
6	810-2012		Rail Set, Filter Pan Roller (includes one left and one right)
7	810-2198		Roller, Filter Pan and Rail
8	826-1372		Nut, 1/4-20 Hex (Pkg. of 10)
9	823-4589	823-4675	Bracket, Lid Support (<i>for units built before Feb 04, use 823-3875</i>)
10			Guide, Filter Pan Lid
	200-3556		Left
	200-6709		Right
11	809-0104	809-0503	Screw, 8-32 X 1/2-inch Slotted Truss Head
12	809-0247		Nut, 8-32 Hex Keps
13	823-3879		Suction Tube
14	200-4408		Rail, Left Filter
15	200-4409		Rail, Right Filter
16			Motor and Gasket Kit
	826-1785	807-3858	100V 50/60 Hz
	826-1712	807-3859	115V 50/60 Hz
	826-1756	807-3860	208V 50/60 Hz
	826-1757	807-3861	220-240V 50/60 Hz
	826-1755	807-3862	250V 50/60 Hz
17	826-1264		Pump and Gasket Kit
	810-2716		Pump, Viking 4GPM 2-piece
	816-0093		Gasket, Pump/Motor
18	807-2484		Valve, 1/4-inch Solenoid
19	813-0165		Elbow, 1/2-inch 90° Street
20	813-0342		Elbow, 1/2-inch 45° Street
21	813-0530		Tee, 1/2-inch X 1/4-inch X 1/2-inch Reducing
22	813-0022		Nipple, 1/2-inch Close
23	813-0838		Nipple, 1/4-inch Close
24	813-0304		Bushing, 1/2-inch to 1/4-inch Flush
25	810-1668		Adapter, 5/8-inch to 1/2-inch NPT Male
26	810-1669		Adapter, 5/8-inch to 1/2-inch NPT Female
27	810-1680		Flexline, 6.5-inch Oil Return
28	810-1369		Flexline, 17.5-inch Oil Return

* Not illustrated.

Use standard part.

Continued on next page...

29	810-1055		Flexline, 11.5-inch Oil Return
30	807-3828		Cable, FootPrint Pro Pump Motor
31	826-1375	809-0401	Screw, 10-32 X 3/4-inch Hex Trim Head (Pkg. of 5)
32	200-7112		Bridge, Filter Motor
33	210-3149		Support, Contactor Box
34	813-0003		Tee, 1/2-Inch
35	813-0298		Nipple, 1/2-inch 2.0-inch
36	813-0537		Nipple, 1/4-inch 2.0-inch
37	810-2493		Fitting, 1/4-inch X 90° Quick-Connect
38	810-1160		Flexline, 3.0-inch Oil Return
*		810-1043	Flexline, 9.5-inch Oil Return
*		810-1057	Flexline, 13.0-inch Oil Return

* Not illustrated.

■ Use standard part.

2.7 Frypot Assemblies and Associated Parts

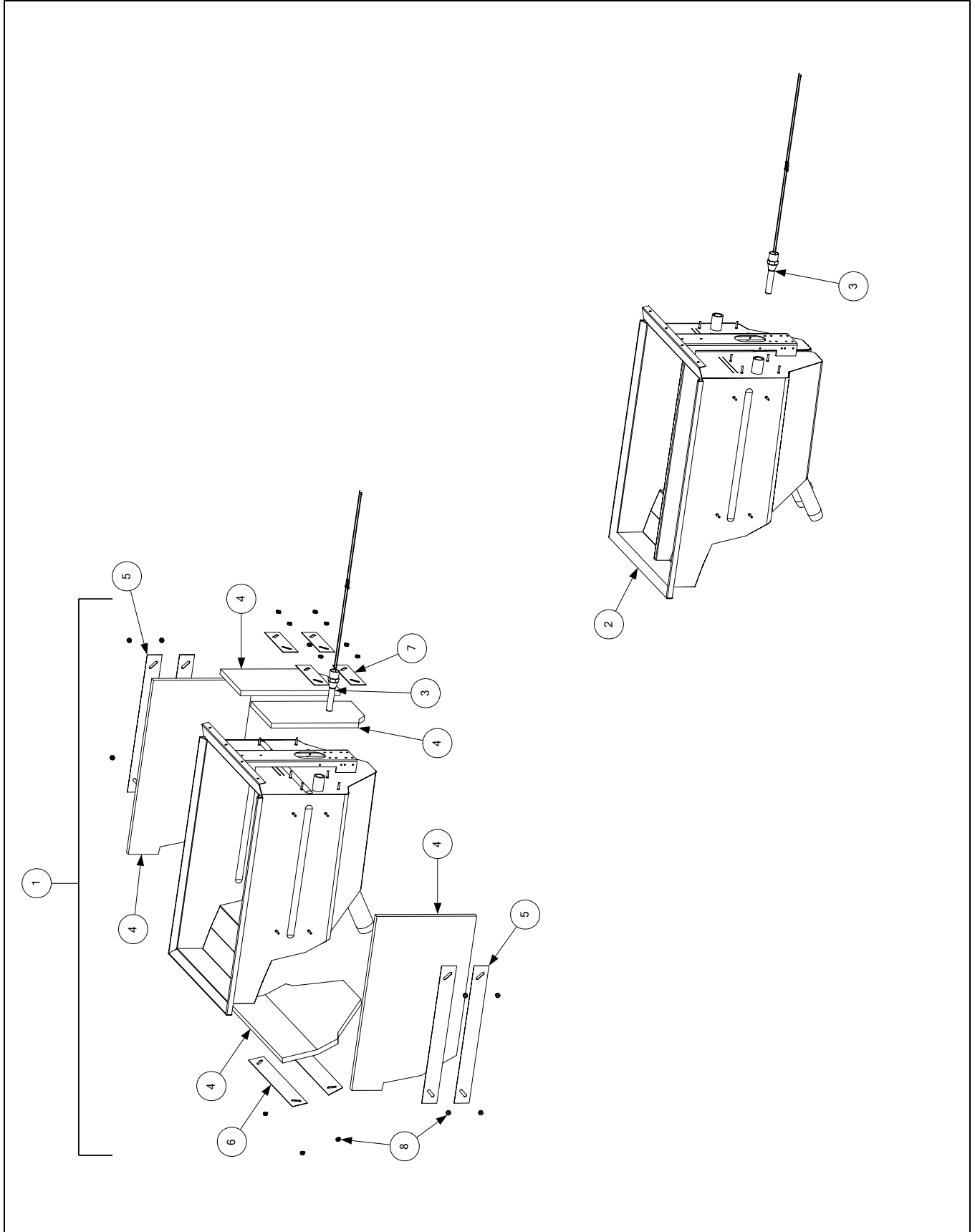

ITEM	PART#	COMPONENT
1	823-4776SP	Frypot, Full-vat
2	823-4779	Frypot, Dual-vat
*	823-4747SP	Frypot, Full-vat, Filter Magic
*	823-4777	Frypot, Dual-vat, Filter Magic
*	823-2452SP	Frypot, Full-vat, EPRI/Triac (with insulation, 806-8167SP)
*	823-2461	Frypot, Dual-vat, EPRI/Triac (with insulation, 106-4582SP)
*	823-5001	Frypot, Full-vat, EPRI/Triac with Filter Magic (with insulation, 106-4575SP)
*	823-5002	Frypot, Dual-vat, EPRI/Triac with Filter Magic (with insulation, 106-4576SP)
3		Thermostat Assembly, High-Limit
	806-7543	Non-CE Full Vat 425°F (218°C) (Color-Coded Black)
	806-8035	Non-CE Dual Vat 435°F (224°C) (Color-Coded Red)
	806-8132	CE 415°F (213°C) used in 14 & 17kW fryers (Color-Coded Yellow)
	806-8536	CE 405°F (207°C) used in 22 kW fryers (Color-Coded White)
4	812-0211	Insulation, Kaowool 17-inch X 10-inch X ½-inch (4 required per pot)
5	900-4100	Retainer, Side Insulation
6	900-4101	Retainer, Front Insulation
7	900-1345	Retainer, Rear Insulation
8	826-1376	Nut, 10-32 Keps Hex (Pkg. of 10)

* Not illustrated.

2.8 Oil Return System Components

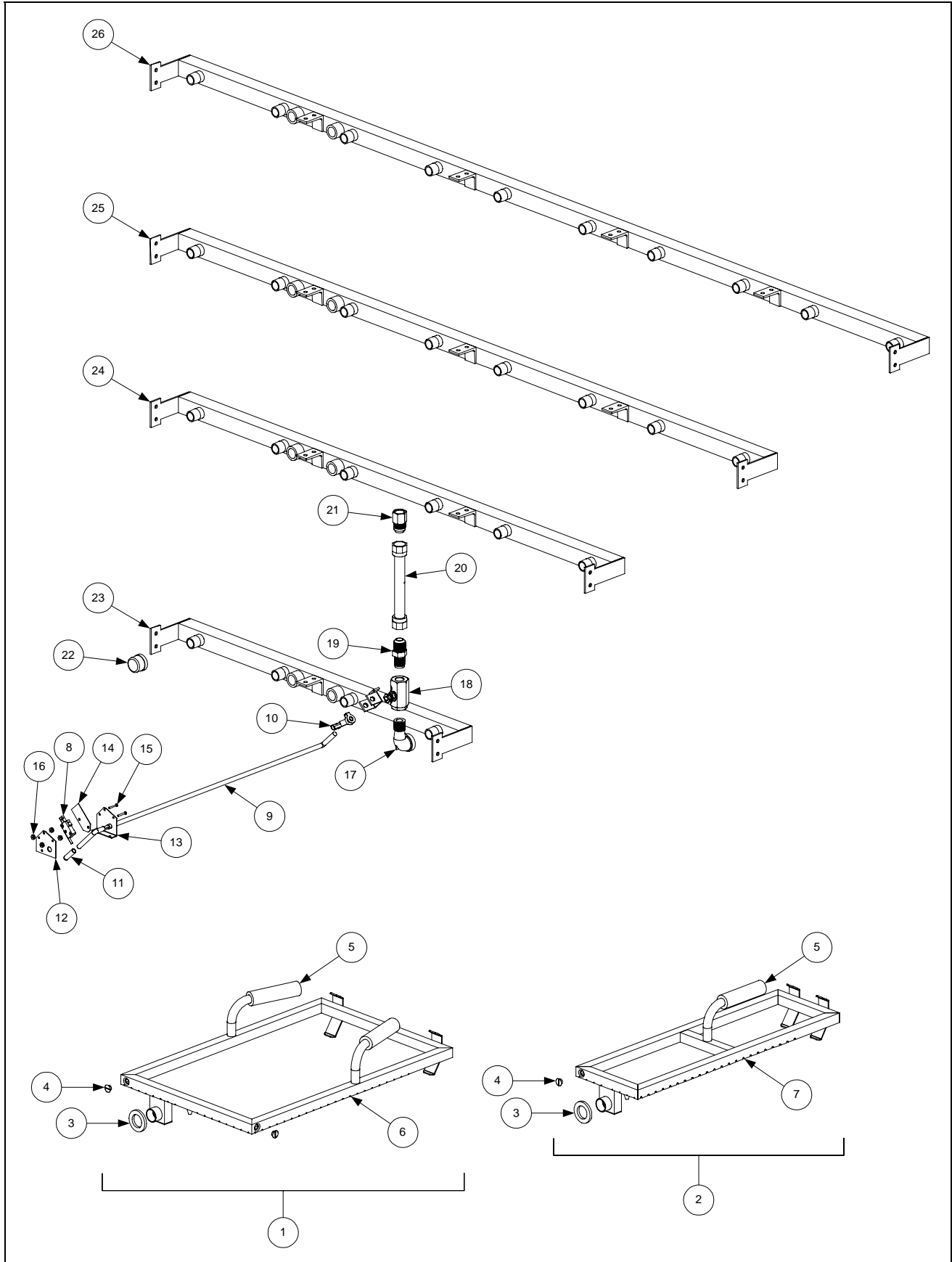

ITEM	STANDARD PART #	EURO-LOOK PART #	COMPONENT
1	806-4505SP		Power Shower Assembly, Full-Vat
2	806-4527SP		Power Shower Assembly, Dual-Vat
3	826-0992		Seal, Power Shower (Pkg. of 3)
4	809-0415		Screw, Power Shower Cleanout
5	814-0001		Grip, Power Shower Handle
6	823-1486		Power Shower, Full-Vat
7	823-1510		Power Shower, Dual-Vat
8	807-2103		Microswitch, Oil Return
9	810-2330		Handle, Oil Return Valve
10	809-0601		Clip, Clevis
11	810-0677		Grip, Oil Return Valve Handle
12	200-5401		Bracket, Handle Retainer
13	200-2520SP		Bracket, Oil Return Microswitch
14	816-0220		Insulation, Oil Return Microswitch
15	826-1359		Screw, 4-40 X 3/4-inch Slotted Pan Head (Pkg. of 25)
16	826-1366		Nut, 4-40 Keps Hex (Pkg. of 25)
17	813-0165		Elbow, 1/2-inch X 90° Street
18	810-0278		Valve, 1/2-inch Ball
19	810-1668		Adapter, 5/8-inch to 1/2-inch NPT Male
20	810-1680		Flexline, 6.5-inch
21	810-1669		Adapter, 5/8-inch to 1/2-inch NPT Female
22	813-0469		Cap, 1/2-inch NPT Pipe
23	810-2255		Manifold, Two-Station Fryer (<i>use 810-2543 for non-filter units</i>)
24	810-2256		Manifold, Three-Station Fryer (<i>use 810-2544 for non-filter units</i>)
25	810-2257		Manifold, Four-Station Fryer (<i>use 810-2545 for non-filter units</i>)
26	810-2312		Manifold, Five-Station Fryer (<i>use 810-2546 for non-filter units</i>)

* Not illustrated.

■ Use standard part.



Frymaster[®]

Enodis[®]

One Company, Countless Solutions

Frymaster, L.L.C., 8700 Line Avenue, PO Box 51000, Shreveport, Louisiana 71135-1000
Shipping Address: 8700 Line Avenue, Shreveport, Louisiana 71106

TEL 1-318-865-1711

FAX (Parts) 1-318-219-7140

(Tech Support) 1-318-219-7135

PRINTED IN THE UNITED STATES

SERVICE HOTLINE
1-800-551-8633

819-5990
MAR 2008