

FilterQuick™ FQE30

Electric Fryer

Service Manual

This manual is updated as new information and models are released. Visit our website for the latest manual.



FOR YOUR SAFETY

Do Not Store or use gasoline or other flammable vapors and liquids in the vicinity of this or any other appliance.



Part Number: FRY_SM_8197110 09/2015

Original Instructions

NOTICE

IF, DURING THE WARRANTY PERIOD, THE CUSTOMER USES A PART FOR THIS MANITOWOC FOOD SERVICE EQUIPMENT OTHER THAN AN UNMODIFIED NEW OR RECYCLED PART PURCHASED DIRECTLY FROM FRYMASTER, OR ANY OF ITS FACTORY AUTHORIZED SERVICERS, AND/OR THE PART BEING USED IS MODIFIED FROM ITS ORIGINAL CONFIGURATION, THIS WARRANTY WILL BE VOID. FURTHER, FRYMASTER DEAN AND ITS AFFILIATES WILL NOT BE LIABLE FOR ANY CLAIMS, DAMAGES OR EXPENSES INCURRED BY THE CUSTOMER WHICH ARISE DIRECTLY OR INDIRECTLY, IN WHOLE OR IN PART, DUE TO THE INSTALLATION OF ANY MODIFIED PART AND/OR PART RECEIVED FROM AN UNAUTHORIZED SERVICER.

NOTICE

This appliance is intended for professional use only and is to be operated by qualified personnel only. A Frymaster Authorized Servicer (FAS) or other qualified professional should perform installation, maintenance, and repairs. Installation, maintenance, or repairs by unqualified personnel may void the manufacturer's warranty.

NOTICE

This equipment must be installed in accordance with the appropriate national and local codes of the country and/or region in which the appliance is installed.

⚠ DANGER

All wiring connections for this appliance must be made in accordance with the wiring diagrams furnished with the equipment. Wiring diagrams are located on the inside of the fryer door.

⚠ DANGER

Copper wire suitable for at least 167°F (75°C) must be used for power connections.

⚠ DANGER

The electrical power supply for this appliance must be the same as indicated on the rating and serial number plate located on the inside of the fryer door.

⚠ DANGER

This appliance must be connected to the voltage and phase as specified on the rating and serial number plate located on the inside of the fryer door.

NOTICE TO U.S. CUSTOMERS

This equipment is to be installed in compliance with the basic plumbing code of the Building Officials and Code Administrators International, Inc. (BOCA) and the Food Service Sanitation Manual of the U.S. Food and Drug Administration.

⚠ DANGER

Improper installation, adjustment, maintenance or service, and unauthorized alterations or modifications can cause property damage, injury, or death. Read the installation, operating, and service instructions thoroughly before installing or servicing this equipment.

⚠ DANGER

The front ledge of this appliance is not a step! Do not stand on the appliance. Serious injury can result from slips or contact with the hot oil.

NOTICE TO OWNERS OF UNITS EQUIPPED WITH CONTROLLERS

U.S.

This device complies with Part 15 of the FCC rules. Operation is subject to the following two conditions: 1) This device may not cause harmful interference, and 2) This device must accept any interference received, including interference that may cause undesired operation. While this device is a verified Class A device, it has been shown to meet the Class B limits.

CANADA

This digital apparatus does not exceed the Class A or B limits for radio noise emissions as set out by the ICES-003 standard of the Canadian Department of Communications.

Cet appareil numérique n'émet pas de bruits radioélectriques dépassant les limites de classe A et B prescrites dans la norme NMB-003 édictée par le Ministre des Communications du Canada.

 DANGER

Do not store or use gasoline or other flammable liquids or vapors in the vicinity of this or any other appliance.

 DANGER

The crumb tray in fryers equipped with a filter system must be emptied into a fireproof container at the end of frying operations each day. Some food particles can spontaneously combust if left soaking in certain shortening material.

 WARNING

Do not bang fry baskets or other utensils on the fryer's joiner strip. The strip is present to seal the joint between the fry vessels. Banging fry baskets on the strip to dislodge shortening will distort the strip, adversely affecting its fit. It is designed for a tight fit and should only be removed for cleaning.

 WARNING

Do not attach accessories to this fryer unless fryer is secured from tipping. Personal injury may result.

 WARNING

This equipment is intended for indoor use only. Do not install or operate this equipment in outdoor areas.

 DANGER

Adequate means must be provided to limit the movement of this appliance without depending on or transmitting stress to the electrical conduit. A restraint kit is provided with the fryer. If the restraint kit is missing contact your local KES.

 DANGER

Prior to movement, testing, maintenance and any repair on your Frymaster fryer, disconnect all electrical power from the fryer.

Table of Contents

Section 1: Service Procedures

CAUTIONARY STATEMENTS	i
ELECTRICAL POWER SPECIFICATIONS	v
1.1 General	1-1
1.1.1 Reading Model Numbers	1-1
1.2 Replacing a Controller or Controller Wiring Harnesses.....	1-1
1.3 Replacing Component Box Components	1-2
1.4 Replacing a High-Limit Thermostat	1-3
1.5 Replacing a Temperature Probe	1-4
1.6 Replacing a Heating Element.....	1-5
1.7 Replacing Contactor Box Components	1-7
1.8 Replacing a Frypot.....	1-9
1.9 Built-In Filtration System Service Procedures.....	1-10
1.9.1 Filtration System Problem Resolution	1-10
1.9.2 Replacing the Filter Motor, Filter Pump and Related Components	1-11
1.9.3 Replacing the Filter Transformer or Filter Relay	1-12
1.10 Basket Lift Service Procedures	1-14
1.11 ATO (Automatic Top-Off) Service Procedures	1-14
1.11.1 ATO (Automatic Top-Off) Troubleshooting)	1-15
1.11.2 ATO (Automatic Top-Off) Board Pin Positions and Harnesses	1-17
1.11.3 Replacing the ATO board, ATO Pump Relay or Transformer	1-18
1.11.4 Replacing the ATO Pump or Solenoid.....	1-18
1.12 MIB (Manual Interface Board) Service Procedures	1-18
1.12.1 Manually Draining, Refilling or Filtering using the MIB board.....	1-19
1.12.2 MIB (Manual Interface Board) Troubleshooting.....	1-20
1.12.3 MIB (Manual Interface Board) Pin Positions and Harnesses	1-22
1.12.4 MIB (Manual Interface Board) Display Characters	1-23
1.12.5 Replacing the MIB Board	1-23
1.12.6 Control Power Reset Switch	1-23
1.13 Bulk Service Issues	1-24
1.13.1 Bulk MIB Tests.....	1-24
1.13.2 Bulk Wiring	1-25
1.13.3 Bulk Oil System Plumbing Schematic	1-26
1.13.4 Bulk Oil Test Quick Reference	1-26
1.14 AIF (Automatic Intermittent Filtration) Service Procedures	1-28
1.14.1 AIF (Automatic Intermittent Filtration) Troubleshooting.....	1-29
1.14.2 AIF (Automatic Intermittent Filtration) Actuator Board Pin Positions	1-30
1.14.3 Replacing an AIF (Automatic Intermittent Filtration) Board	1-31
1.14.4 Replacing a Rotary Actuator.....	1-31
1.15 FilterQuick™ Controller Service Procedures	1-32
1.15.1 FilterQuick™ Controller Troubleshooting	1-32
1.15.2 FilterQuick™ Controller Useful Codes	1-34
1.15.3 Service Required Errors	1-35
1.15.4 Error Log Codes.....	1-36
1.15.5 FilterQuick™ Filter Error Flowchart.....	1-37
1.15.6 Menu Trees.....	1-38
1.15.6.1 FilterQuick™ Controller Setup Menu Tree.....	1-38
1.15.6.2 FilterQuick™ Filter and Info Mode Menu Tree	1-39
1.15.7 FilterQuick™ Controller Pin Positions and Harnesses	1-40
1.15.8 OQS (Oil Quality Sensor) Troubleshooting	1-41
1.16 Loading and Updating Software	1-42
1.17 FilterQuick™ FQE Data Network Flowchart.....	1-43
1.18 Interface Board Diagnostic Chart	1-44
1.19 Probe Resistance Chart	1-45

Wiring Diagrams

See 8197225 FilterQuick Elec Wiring Diagrams Manual

ELECTRICAL POWER SPECIFICATIONS

Three (3) Phase Requirements						
MODEL	kW	VOLTAGE	WIRE SERVICE	MINIMUM WIRE SIZE		AMPS (per leg)
				AWG	(mm)	
FQEL14	14	208	3	6	(4.11)	39
FQEL14	14	240	3	6	(4.11)	34
FQEL14	14	480	3	8	(2.59)	17
FQEL14	14	220/380	4	6	(4.11)	22
FQEL14	14	230/400	4	6	(4.11)	21
FQEL14	14	240/415	4	6	(4.11)	20

Single (1) Phase Requirements						
MODEL	kW	VOLTAGE	WIRE SERVICE	MINIMUM WIRE SIZE		AMPS (per leg)
				AWG	(mm)	
FQEL14	14	208	2	3	(5.83)	67
FQEL14	14	220	2	3	(5.83)	63
FQEL14	14	240	2	4	(5.19)	58

FILTERQUICK™ FQE30 SERIES ELECTRIC FRYERS

CHAPTER 1: SERVICE PROCEDURES

1.1 General

Before performing any maintenance on your Frymaster fryer, disconnect the fryer from the electrical power supply.

⚠ WARNING

To ensure the safe and efficient operation of the fryer, the electrical plug(s) must be fully engaged and locked in their pin and sleeve socket.

When electrical wires are disconnected, it is recommended that they be marked in such a way as to facilitate re-assembly.

1.1.1 Reading Model Numbers

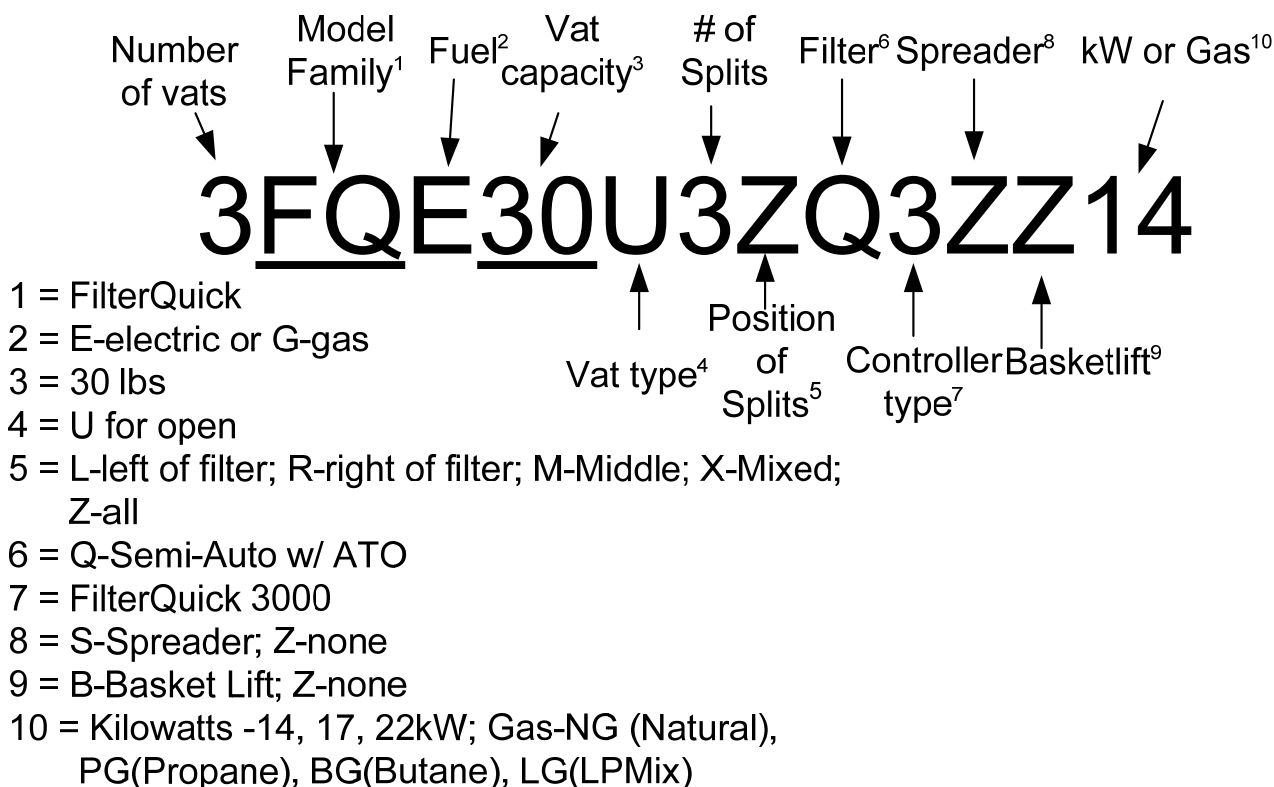

1.2 Replacing the Controller or the Controller Wiring Harnesses

1. Disconnect the fryer from the electrical power supply.
2. Unscrew the filter push pull handle knobs.
3. Open the control panel by removing the screws on the bottom of the bezel. Carefully lower the bezel.
4. Remove the two screws from the upper corners of the controller. The controller is hinged at the bottom and will swing open from the top.

- Unplug the wiring harnesses from the connectors on the back of the controller marking their position for reassembly and disconnect the grounding wires from the terminals. Remove the controller by lifting it from the hinged slots in the control panel frame.

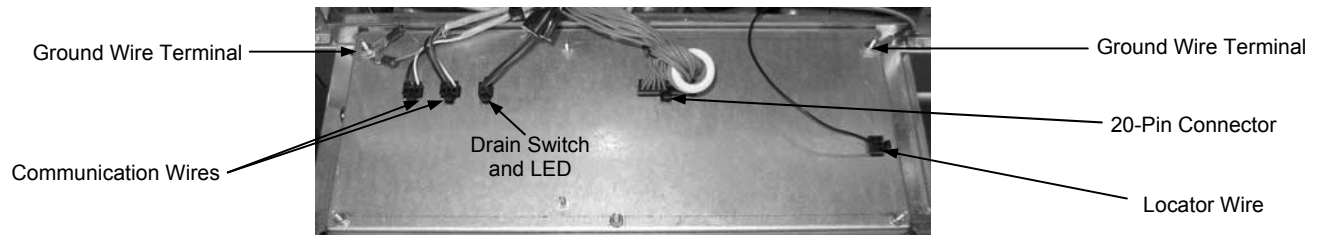

- Install the replacement controller. Reinstall the control panel assembly by reversing steps 1 thru 5.
- Setup the controller following the instructions on page 1-3 in the FilterQuick™ Controller Operation manual. Setup **MUST** be performed prior to readdress.
- Once setup is complete on all replaced controllers, CYCLE POWER TO ENTIRE FRYER SYSTEM. See section 1.12.6 to reset control power.
- Check software version and if necessary update the software. If a software update was necessary, follow the instructions to update the software in section 1.16.

1.3 Replacing Component Box Components

- Disconnect the fryer from the electrical supply.
- Drain cooking oil below the level of the probe or thermostat.
- Unscrew the filter push pull handle knobs.
- Open the control panel by removing the screws on the bottom of the bezel. Carefully lower the bezel.
- Remove the top two screws in the upper corners of the controller.
- Swing the controller out from the top and allow it to rest on its hinge tabs.
- Disconnect the controller wiring harness and ground wire from the back of the controller and remove the controller by lifting it from the hinge slots in the control panel frame.
- Disconnect the wiring from the component to be replaced, being sure to make a note of where each wire was connected.
- Dismount the component to be replaced and install the new component, ensuring that any required spacers, insulation, washers, etc. are in place.

NOTE: If more room to work is required, the control panel frame assembly may be removed by removing the hex-head screws which secure it to the fryer cabinet (see illustration below). If this option is chosen, all controller assemblies must be removed per steps 1 thru 7 above. The cover plate, on the lower front of the component box, may also be removed to allow additional access if desired.

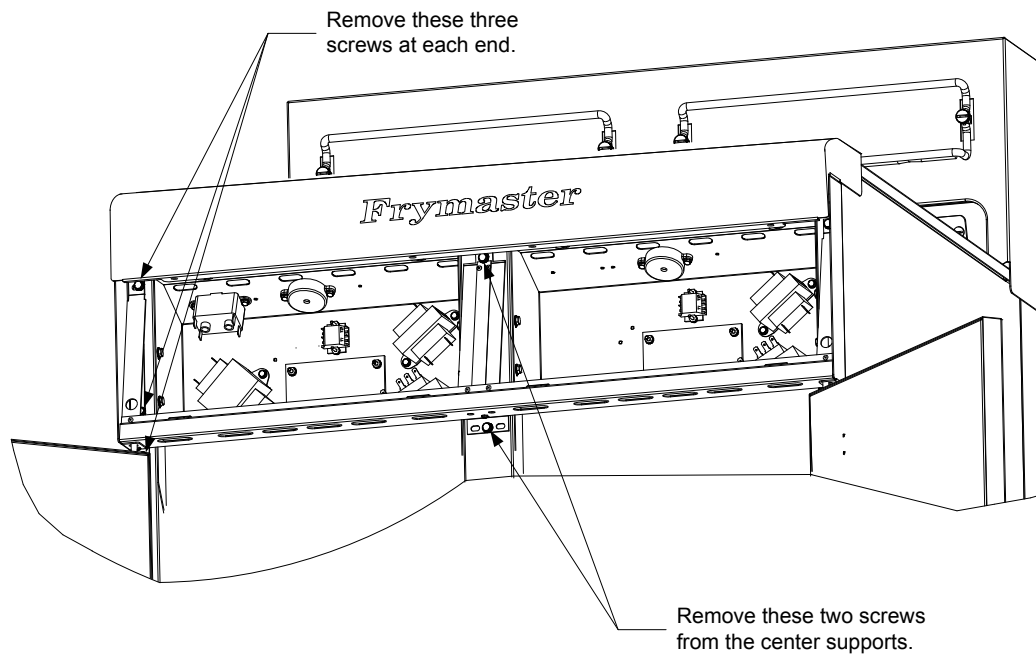

Removing the Control Panel Frame and Top Cap Assembly

10. Reconnect the wiring disconnected in step 7, referring to your notes and the wiring diagrams on the fryer door to ensure that the connections are properly made. Also, verify that no other wiring was disconnected accidentally during the replacement process.
11. Reverse steps 1 through 8 to complete the replacement and return the fryer to service.

1.4 Replacing a High-Limit Thermostat

1. Remove the filter pan and lid from the unit. Drain the frypots into a Shortening Disposal Unit (SDU) or other appropriate **METAL** container using the controller “drain to pan option” or using the MIB board in manual mode.

⚠ DANGER

DO NOT drain more than one full frypot or two split frypots into the SDU at one time.

2. Disconnect the fryer from the electrical power supply and reposition it to gain access to the rear of the fryer.
3. Remove the four screws from both the left and right sides of the lower back panel.
4. Locate the high-limit that is being replaced and follow the two-black wires to the 12-pin connector C-6. Note where the leads are connected prior to removing them from the connector. Unplug the 12-pin connector C-6 and using a pin-pusher push the pins of the high-limit out of the connector.
5. Carefully unscrew the high-limit thermostat to be replaced.
6. Apply Loctite™ PST 567 or equivalent sealant to the threads of the replacement and screw it securely into the frypot.
7. Insert the leads into the 12-pin connector C-6 (see illustration below). For full-vat units or the left half of a dual-vat unit (as viewed from the rear of the fryer) the leads go into positions 1 and 2 of the connector. For the right half of a dual-vat unit (as viewed from the rear of the fryer), the leads go into positions 7 and 8. In either case, polarity does not matter.

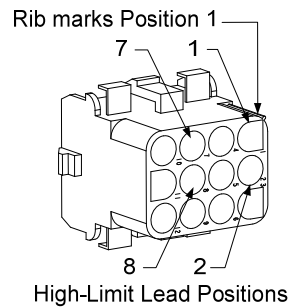

8. Reconnect the 12-pin connecting plug C-6. Use wire ties to secure any loose wires.
9. Reinstall the back panels, contactor plug guards, reposition the fryer under the exhaust hood, and reconnect it to the electrical power supply to return the fryer to service.

1.5 Replacing a Temperature Probe

1. Lift the element out of the oil.
2. Disconnect the fryer from the electrical power supply and reposition it to gain access to the rear of the fryer.
3. Remove the four screws from both sides of the lower back panel. Then remove the two screws on both the left and right sides of the back of the tilt housing. Lift the tilt housing straight up to remove from the fryer.
4. Locate the red (or yellow) and white wires of the temperature probe to be replaced. Note where the leads are connected prior to removing them from the connector. Unplug the 12-pin connector C-6 and using a pin-pusher push the pins of the temperature probe out of the connector.
5. Remove the securing probe bracket and metal tie wraps that secure the probe to the element (see illustration below). Remove the ground clip on the probe shield.

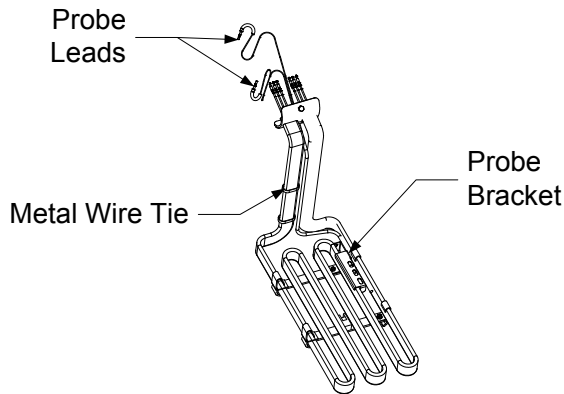

6. Gently pull on the temperature probe and grommet, pulling the wires up the rear of the fryer and through the element tube assembly.
7. Insert the replacement temperature probe (wires first) into the tube assembly ensuring that the grommet is in place. Secure the probe to the elements using the bracket which was removed in Step 5 and the metal tie wraps which were included in the replacement kit.
8. Route the probe wires out of the tube assembly following the element wires down the back of the fryer through the Heyco bushings to the 12-pin connector C-6. Secure the wires to the sheathing with wire ties. Attach the ground clip.
9. Insert the temperature probe leads into the 12-pin connector C-6 (see illustration below). For full-vat units or the right half of a dual-vat unit (as viewed from the rear of the fryer) the red (or yellow) lead goes into position 3 and the white lead into position 4 of the connector. For the left half of a dual-vat unit (as viewed from the rear of the fryer), the red (or yellow) lead goes into

position 9 and the white lead into position 10. **NOTE:** *Right* and *left* refer to the fryer as viewed from the rear.

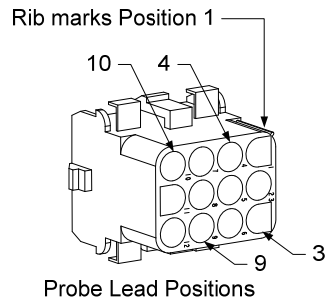

10. Secure any loose wires with wire ties, making sure there is no interference with the movement of the springs. Rotate the elements up and down, making sure that movement is not restricted and that the wires are not pinched.
11. Reinstall the tilt housing, back panels and contactor plug guards. Reposition the fryer under the exhaust hood and reconnect it to the electrical power supply to return the fryer to service.

1.6 Replacing a Heating Element

1. Perform steps 1-5 of section 1.5, *Replacing a Temperature Probe*.
2. Disconnect the wire harness containing the probe wiring, where the temperature probe is attached to the element being replaced. Using a pin pusher, disconnect the probe wires from the 12-pin connector.
3. In the rear of the fryer disconnect the 6-pin connector for the left element (as viewed from the front of the fryer) or the 9-pin connector for the right element from the contactor box. Press in on the tabs on each side of the connector while pulling outward on the free end to extend the connector and release the element leads (see photo below). Pull the leads out of the connector and out of the wire sleeving.

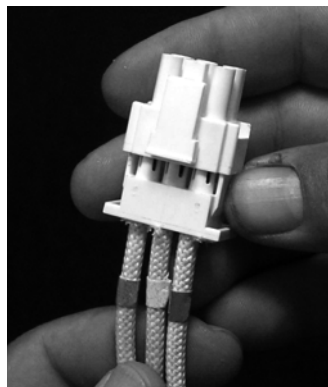

4. Raise the element to the full up position and support the elements.
5. Remove the hex head screws and nuts that secure the element to the tube assembly and pull the element out of the frypot. **NOTE:** The nuts inside the tube can be held and removed using the RE element tube nut spanner, PN# 2304028. Full-vat elements consist of two dual-vat elements clamped together. For full-vat units, remove the element clamps before removing the nuts and screws that secure the element to the tube assembly.
6. If applicable, recover the probe bracket and probe from the element being replaced and install them on the replacement element. Install the replacement element in the frypot, securing it with the

nuts and screws removed in Step 5 to the tube assembly. Ensure the gasket is between the tube and element assembly.

7. Route the element leads through the element tube assembly and into the wire sleeving to prevent chafing. Ensure that the wire sleeving is routed back through the Heyco bushing, keeping it clear from the lift springs (see photos below and on the next page). Also ensure that the wire sleeving extends into the tube assembly to protect the edge of the tube assembly from chafing the wires. Press the pins into the connector in accordance with the diagram below, and then close the connector to lock the leads in place. **NOTE:** It is critical that the wires be routed through the sleeving to prevent chafing.

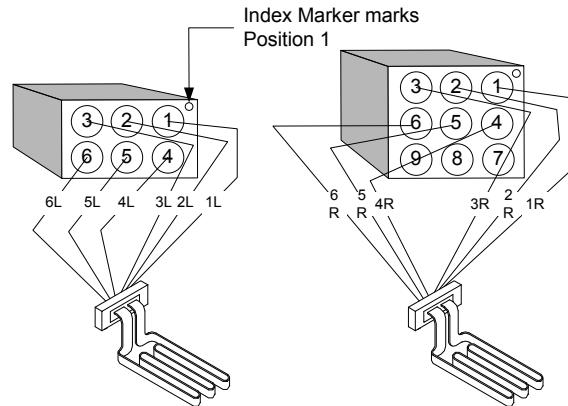

Full vat element wire routing

Pull the element wires through the bushings on either side of the frypot and down the back. Element wires should be routed to the right of the ATO temperature probe on the back wall of the frypot.

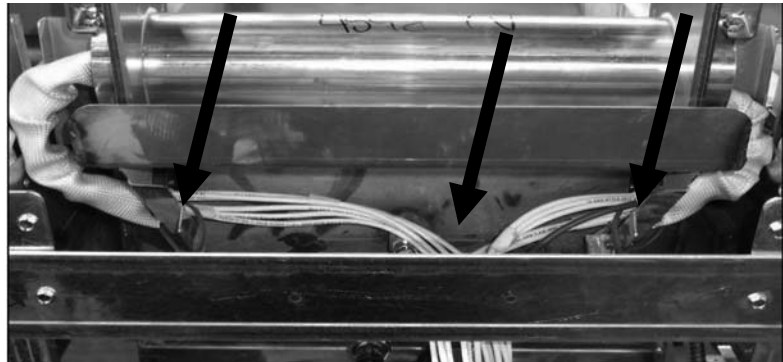

Dual vat element wire routing

Pull the element wires through the bushings on either side of the frypot and down the back. Element wires should be routed to the center of the frypot between the ATO temperature probes.

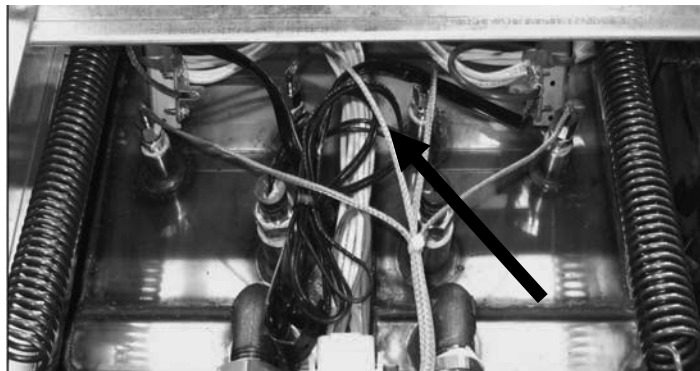

Element grounding and wire routing

To ground the element wires, use the hole in the frypot frame located under the bushing that the element wires pass through. Using a screw through the ground wires ring terminal, connect it to the frypot using the probe ground clip. Use a tie wrap to tie up half of the element wires after the wires are pulled through the bushing. Do not pull tie wrap tight, leave it slack at about one inch

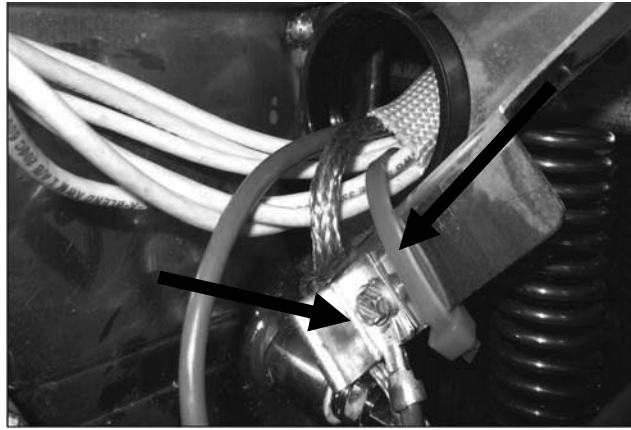

8. Reconnect the element connector ensuring that the latches lock.
9. Insert the temperature probe leads into the 12-pin wiring harness connector (see illustration below). For full-vat units or the right half of a dual-vat unit, the red lead goes into position 3 and the white into position 4. For the left half of a dual-vat unit, the red lead goes into position 9 and the white into position 10. **NOTE: Right and left** refer to the fryer as viewed from the rear.

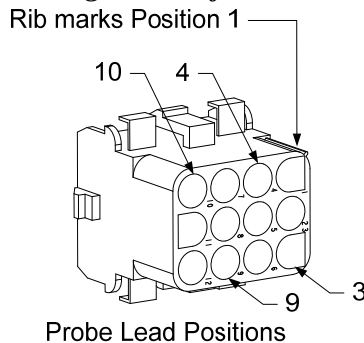

10. Reconnect the 12-pin connector of the wiring harness disconnected in Step 2.
11. Lower the element to the full down position.
12. Reinstall the tilt housing, back panels and contactor plug guard. Reposition the fryer under the exhaust hood, and reconnect it to the electrical power supply.

1.7 Replacing Contactor Box Components

1. If replacing a contactor box component in boxes above the filter pan, first remove the filter pan and lid from the unit. If replacing components in fryers that have ATO boxes, the ATO box may require removal.
2. Disconnect the fryer from the electrical power supply.
3. Remove the two screws securing the cover of the contactor box. The contactor boxes above the filter pan are accessed by sliding under the fryer. They are located to the left and right above the guide rails (see photo below). The contactor boxes for frypots not over the filter pan are accessed by opening the fryer door directly under the affected frypot.

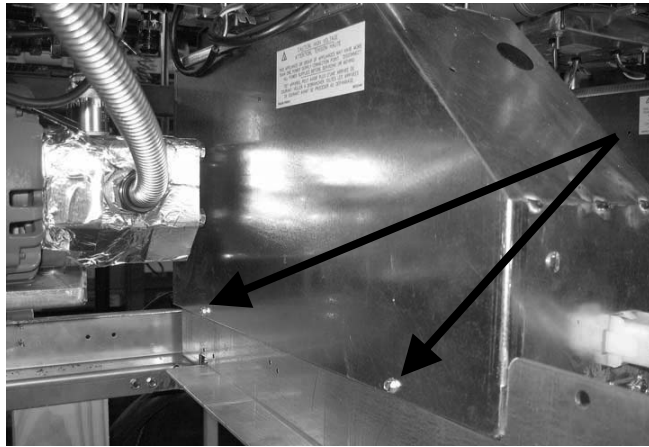

Remove two screws to access contactor box components above the filter pan.

4. The contactors and relays are held on by threaded pin studs so that only removal of the nut is required to replace the component.
5. After performing necessary service, reverse steps 1-4 to return the fryer to operation.

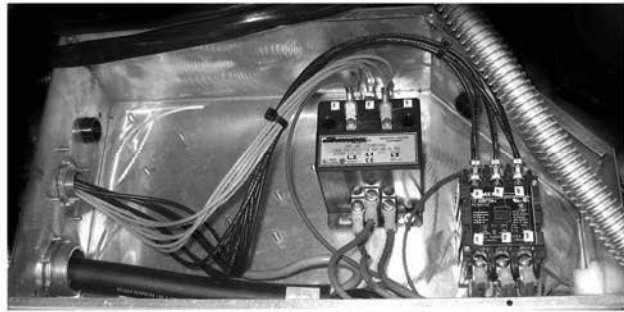
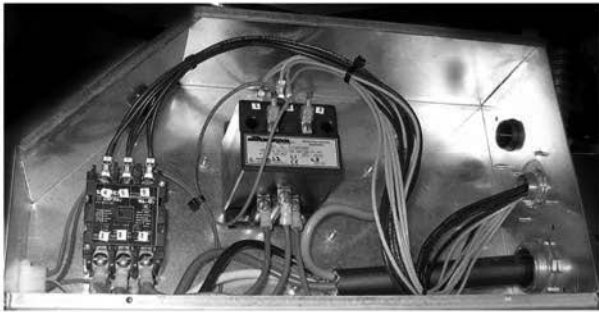

Left and right views of mechanical contactor box components.

Sometimes it is necessary to remove the entire contactor box to repair. Below are the instructions for removing the far left contactor box.

1. Remove fryers from hood and remove all power to fryers.
2. Remove lower back panel.
3. Remove filter pan, lid and downspout splash shield.
4. Remove clevis clip from dispose handle at rear of fryer and let handle drop out of waste valve bracket.
5. Remove two screws holding waste valve handle at front of fryer and remove bracket and handle from fryer.
6. Remove AIF board and tuck wires out of the way of the contactor box for box removal.
7. Remove shipping brace that supports filter pump shelf brace to top of contactor box.
8. Remove contactor box cover.
9. Unplug all wiring from front and rear of contactor box.
10. Remove two screws that hold element wire shield to rear of contactor box and remove wire shield.
11. Remove two screws that support contactor box at rear of box.
12. Remove two screws that support contactor box at front of box.
13. Lift contactor box up to clear left frame rail and slide to the right far enough that the left rear corner of the pump and motor shelf protrude inside of the contactor box slightly.
14. Tip front of contactor box down and to the right slightly and then pull out from opening where filter pan lid would rest.
15. Reverse above steps for reinstallation.

1.8 Replacing a Frypot

1. Drain the frypot into the filter pan or, if replacing a frypot over the filter system, into a Shortening Disposal Unit (SDU) or other appropriate **METAL** container. If replacing a frypot over the filter system, remove the filter pan and lid from the unit.

 **DANGER**

DO NOT drain more than one full frypot or two split frypots into the SDU at one time.

2. Disconnect the fryer from the electrical power supply and reposition it to gain access to both the front and rear.
3. Disconnect the fryer from the electrical supply.
4. Drain cooking oil below the level of the probe or thermostat.
5. Unscrew the filter push pull handle knobs.
6. Open the control panel by removing the screws on the bottom of the bezel. Carefully lower the bezel.
7. Remove the top two screws in the upper corners of the controller.
8. Swing the controller out from the top and allow it to rest on its hinge tabs.
9. Disconnect the controller wiring harness and ground wire from the back of the controller and remove the controller by lifting it from the hinge slots in the control panel frame (see illustration and photo on page 1-1).
10. Remove the controllers by lifting them from the hinge slots in the control panel frame.
11. Remove the tilt housing and back panels from the fryer. The tilt housing must be removed first in order to remove the upper back panel.
12. To remove the tilt housing, remove the hex-head screws from the rear edge of the housing. The housing can be lifted straight up and off the fryer.
13. Remove the control panel by removing the screw in the center and the nuts on both sides.
14. Loosen the component boxes by removing the screws, which secure them in the cabinet.
15. Dismount the top cap by removing the nuts at each end that secure it to the cabinetry.
16. Remove the hex head screw that secures the front of the frypot to the cabinet cross brace.
17. Remove the top-connecting strip that covers the joint with the adjacent frypot.
18. Unscrew the nut located on the front of each section of drain tube, and remove the tube assembly from the fryer.
19. Remove the actuators from the drain and return valves and disconnect the wiring.
20. Disconnect any auto filtration probes and auto top off sensors and wiring.
21. At the rear of the fryer, unplug the 12-pin connector C-6 and, using a pin pusher, disconnect the high-limit thermostat leads. Disconnect any other probe wiring.
22. Disconnect the oil return flexline(s).
23. Raise the elements to the “up” position and disconnect the element springs.
24. Remove the machine screws and nuts that secure the element tube assembly to the frypot. Carefully lift the element assembly from the frypot and secure it to the cross brace on the rear of the fryer with wire ties or tape.
25. Carefully lift the frypot from the fryer and place it upside down on a stable work surface.
26. Recover the drain valve(s), oil return flexline connection fitting(s), actuators, AIF boards and high-limit thermostat(s) from the frypot. Clean the threads and apply Loctite™ PST 567 or equivalent sealant to the threads of the recovered parts and install them in the replacement frypot.
27. Carefully lower the replacement frypot into the fryer. Reinstall the hex head screw removed in step 11 to attach the frypot to the fryer.
28. Position the element tube assembly in the frypot and reinstall the machine screws and nuts removed in step 24.

29. Reconnect the oil return flexlines to the frypot, and replace aluminum tape, if necessary, to secure heater strips to the flexlines.
30. Insert the high-limit thermostat leads disconnected in step 21 (see illustration on page 1-3 for pin positions).
31. Reconnect the actuators, ensuring the correct position of the drain and return valves.
32. Reconnect the auto filtration and auto top off probes.
33. Reinstall the drain tube assembly.
34. Reinstall the top connecting strips, top cap, tilt housing and back panels.
35. Reinstall controllers in the control panel frame and reconnect the wiring harnesses and ground wires.
36. Reposition the fryer under the exhaust hood and reconnect it to the electrical power supply.

1.9 Built-in Filtration System Service Procedures

1.9.1 Filtration System Problem Resolution

One of the most common causes of filtration problems is placing the filter pad/paper on the bottom of the filter pan rather than over the filter screen.

⚠ CAUTION

Ensure that filter screen is in place prior to filter pad/paper placement and filter pump operation. Improper screen placement is the primary cause of filtration system malfunction.

Whenever the complaint is “the pump is running, but no oil is being filtered,” check the installation of the filter pad/paper, and ensure that the correct size is being used. While you are checking the filter pad/paper, verify that the O-rings on the pick-up tube of the filter pan are in good condition. A missing or worn O-ring allows the pump to take in air and decrease its efficiency.

If the pump motor overheats, the thermal overload will trip and the motor will not start until it is reset. If the pump motor does not start, press the red reset switch (button) located on the rear of the motor.

If the pump starts after resetting the thermal overload switch, then something is causing the motor to overheat. A major cause of overheating is when several frypots are filtered sequentially, overheating the pump and motor. Allow the pump motor to cool at least 30 minutes before resuming operation. Pump overheating can be caused by:

- Solidified shortening in the pan or filter lines, or
- Attempting to filter unheated oil or shortening (cold oil is more viscous, overloading the pump motor and causing it to overheat).

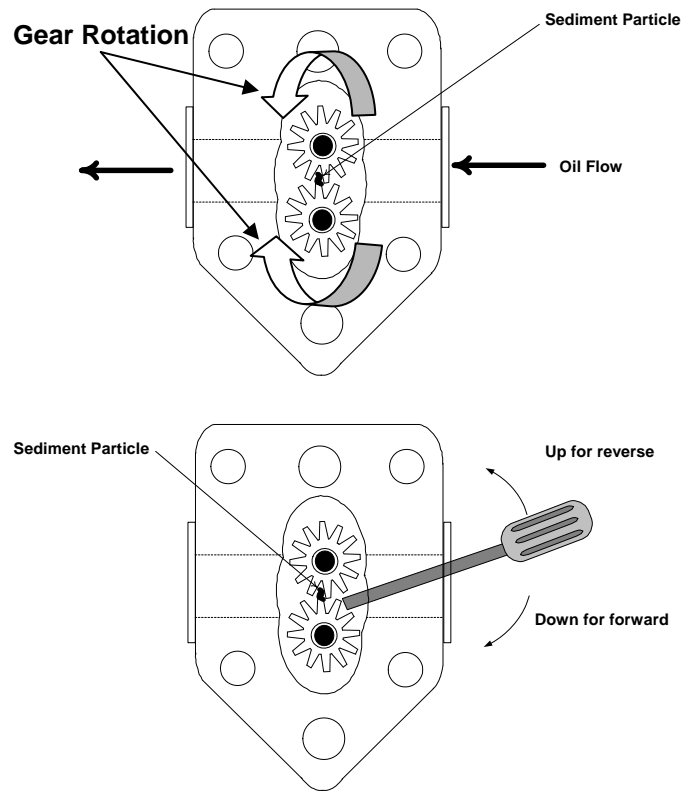

If the motor runs but the pump does not return oil, there is a blockage in the pump. Incorrectly sized or installed paper/pads will allow food particles and sediment to pass through the filter pan and into the pump. When sediment enters the pump, the gears bind, causing the motor to overload, again tripping the thermal overload. Shortening that has solidified in the pump will also cause it to seize, with the same result.

A pump seized by debris or hard shortening can usually be freed by manually moving the gears with a screwdriver or other instrument.

Disconnect power to the filter system, remove the input plumbing from the pump, and use a screwdriver to manually turn the gears.

- Turning the pump gears in reverse will release a hard particle.
- Turning the pump gears forward will push softer objects and solid shortening through the pump and allow free movement of the gears.

Incorrectly sized or installed paper/pads will also allow food particles and sediment to pass through and clog the suction tube on the bottom of the filter pan. Particles large enough to block the suction tube may indicate that the crumb tray is not being used. Pan blockage can also occur if shortening is left in the pan and allowed to solidify. Blockage removal can be accomplished by forcing the item out with an auger or drain snake. Compressed air or other pressurized gases should **NEVER** be used to force out the blockage.

1.9.2 Replacing the Filter Motor, Filter Pump, and Related Components

1. Remove the filter pan and lid from the unit. Drain the frypots into a Shortening Disposal Unit (SDU) or other appropriate metal container.

<p>⚠ DANGER <u>DO NOT</u> drain more than one full frypot or two split frypots into the SDU at one time.</p>
--

2. Disconnect the fryer from the electrical power supply and reposition it to gain access to both the front and rear.
3. Disconnect the flexline running to the oil-return manifold at the rear of the fryer as well as the pump suction flexline at the end of the filter pan connection (see photo to the right).
4. Loosen the nut and bolt which secure the bridge to the oil-return manifold.
5. Remove the cover plate from the front of the motor and disconnect the motor wires.
6. Remove the two nuts and bolts which secure the front of the bridge to the cross brace and carefully slide the bridge rearward off the cross brace until its front end can be lowered to the floor. Undo the single nut holding it in place in back. Be careful not to let the rear of the bridge slip off the manifold at this point.
7. Get a good grip on the bridge, carefully pull it forward off the oil-return manifold, and lower the entire assembly to the floor. Once on the floor, pull the assembly out the front of the fryer.
8. When required service has been completed, reverse steps 4-7 to reinstall the bridge.

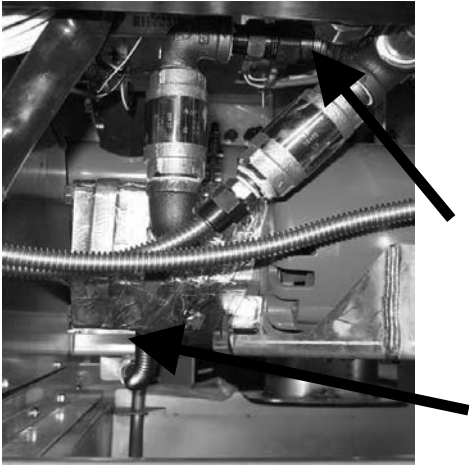

Disconnect flexlines indicated by the arrows.

9. Reconnect the unit to the electrical power supply, and verify that the pump is functioning correctly using the MIB board in manual mode (i.e., using the fill function when engaged, the motor should start and there should be strong suction at the intake fitting and outflow at the rear flush port.)
10. When proper operation has been verified, reinstall the back panels and the filter pan and lid.
11. Reconnect it to the electrical power supply and reposition the fryer under the exhaust hood to return the fryer to service.

1.9.3 Replacing the Transformer or Filter Relay

Disconnect the fryer from the electrical power supply. Remove the left controller from the fryer to expose the interior of the left component box. The transformer and relay on the left are located as shown in the illustration below. **NOTE:** The right component box is identical to the left except that the transformer and relay on the left side are not present. Once replaced, reconnect the power.

When replacing a filter relay in the left component box, ensure the 24VDC relay (8074482) is used. Similar Frymaster fryers use a 24VAC relay, which can lead to confusion. The 24VDC is used in the FilterQuick™ fryer.

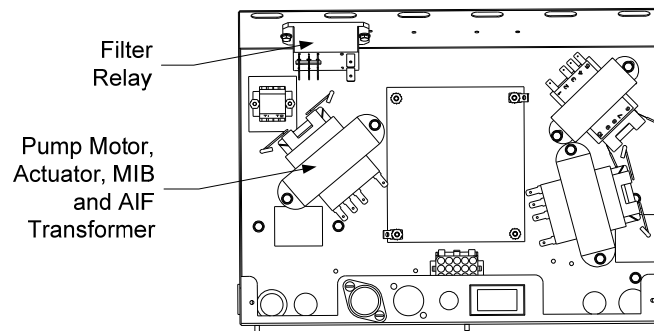

1.10 Basket Lift Service Procedures

FQE30™ Series electric fryers may be equipped with automatic basket lifts. Basket lifts always come in pairs, although each operates independently.

A **modular basket lift** (illustrated on the following page) is a self-contained sub-assembly consisting of a pair of toothed rods, which support removable basket lift arms, a pair of reversible-drive gear motors, and four microswitches. The gear motors engage the teeth of the rods, moving them up or down depending upon the motors' direction of rotation. The microswitches at the upper and lower limits of movement stop the motors when the basket is in the full up or full down position.

Timing circuitry in the controller initiates and stops basket lift operation depending upon the variables programmed by the operator. When the product button is pressed, the timing circuitry activates a coil in the basket lift relay to supply power to the lower microswitch. The microswitches stop the motor at the lift's upper and lower travel limits and reverse the direction of current flow thus reversing the motor direction.

When the product button is pushed on the controller, current flows through a coil in the basket lift relay, causing the lower circuit to be activated. The basket lift lowers, closing the normally open upper-micro-switch. When the downward-moving rod opens the lower normally closed microswitch, the power to the motor ceases to flow. When the controller times out, the current to the relay coil is cut, allowing the upper circuit to be activated. The basket lift rises and re-closes the lower microswitch. When the basket lift rod clears the upper microswitch, the microswitch reopens, power to the circuit is cut, and the motor stops. Pushing the product button restarts the cycle.

Problems with the basket lift can be grouped into three categories:

- Binding/jamming problems
- Motor and gear problems
- Electronic problems

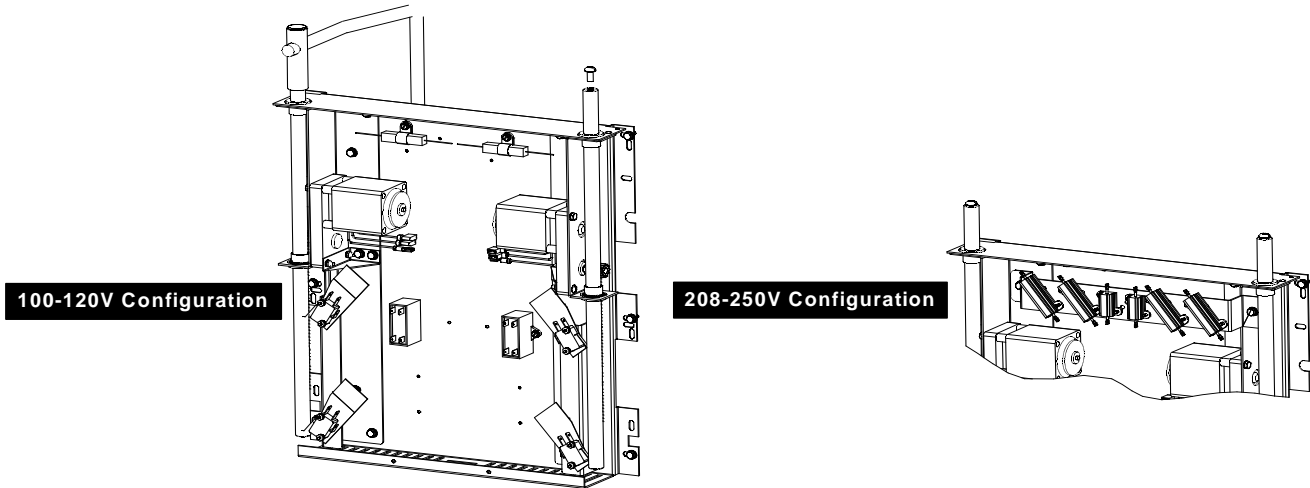

Binding and Jamming Issues

Noisy, jerky or erratic movement of the lifts is usually due to lack of lubrication of the rods and their bushings. Apply a light coat of Lubriplate[®] or similar lightweight white grease to the rod and bushings to correct the problem.

With the modular basket lift, another possible cause of binding is improper positioning of the motor, which prevents the gear from correctly engaging the teeth in the rod. To correct the problem, loosen the screws that hold the motor in place and move it forward or backward until the rod has just enough slack to be rotated slightly.

Motor and Gear Issues

With the modular basket lift, the most likely problem to be encountered in this category is erratic motion of the lift due to a worn drive gear. Failure to keep the lift rod and bushings properly lubricated will cause unnecessary wear of the gear. The problem is corrected by replacing the worn gear.

If the lift cycles correctly but fails to remain in the up position (i.e., goes up, but then slowly settles back down into the frypot), the problem is a failed motor brake. A failed motor brake cannot be repaired and requires replacement of the motor itself.

If power is reaching the motor but the motor fails to run, the motor is burned out and must be replaced.

Electronic Issues

Within this category are problems associated with the relays, microswitches, capacitors, resistors, interface board, wiring, and controls. The most common problem in this category is a lift that continuously travels up and down. This is usually caused by a microswitch that is out of adjustment. Troubleshooting the electronics of a modular basket lift is simply a process of verifying current flow through the individual components up to and including the motor. Using a multimeter set to the 250 VAC range, check the connections on both sides of the component for the presence of the applied line voltage. The schematic below and the wiring diagram on page 2-8 and 2-9 can identify the components and wiring connection points.

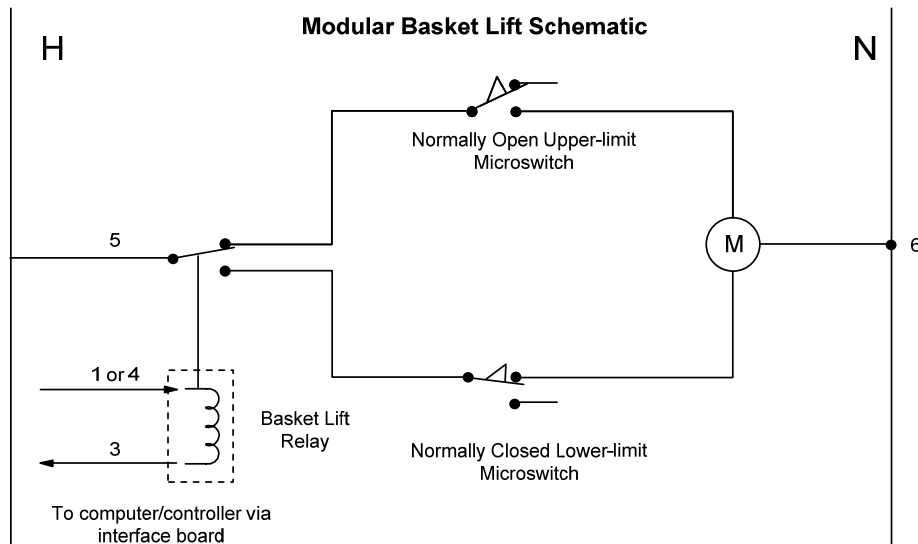

1.11 ATO (Automatic Top-off) Service Procedures

The automatic top-off system is activated when the oil level falls below a sensor in the rear of the frypot. The signal is sent to the ATO board to engage the return actuator to the frypot and turn on the ATO pump. The pump draws oil from the JIB (Jug In Box) through the rear return manifold into the rear of the frypot. Once the oil level has satisfied the sensor, the pump turns off and the actuator closes.

The ATO board is located inside the box, behind the JIB (see Figure 1). The power for the ATO board is supplied from the right hand component box. The power passes through the transformer inside the ATO box to the board.

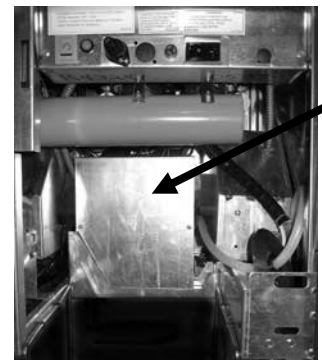

Figure 1

1.11.1 ATO (Automatic Top-off) Troubleshooting

Problem	Probable Causes	Corrective Action
Frypot tops off cold.	Incorrect setpoint	Ensure setpoint is correct.
No power to ATO board	<ul style="list-style-type: none"> A. J5 connection unplugged B. Fuse blown C. Transformer malfunction 	<ul style="list-style-type: none"> A. Check to ensure J5 on front of ATO board is fully locked into connector. B. Ensure fuse below right control box is not blown and fuse on the right side of ATO box is not blown. C. Check that proper voltage is present at transformer. See table in section 1.11.2.
One vat tops off but other vats fail to top off.	<ul style="list-style-type: none"> A. Loose wire connection. B. Actuator issue 	<ul style="list-style-type: none"> A. Ensure all wiring harnesses are securely connected to ATO board and solenoids. B. Check return actuator to ensure actuator is functional.
Incorrect vat tops off.	<ul style="list-style-type: none"> A. Wired incorrectly. B. Flexlines connected to wrong vat. 	<ul style="list-style-type: none"> A. Check wiring. B. Switch flexlines to correct vat.
One vat doesn't top off.	<ul style="list-style-type: none"> A. Filter error exists. B. Actuator, pump, loose connection, RTD or ATO issue. 	<ul style="list-style-type: none"> A. Clear filter error properly. When CHANGE FILTER PAPER YES/NO is displayed, do NOT press any button until the pan has been removed for at least thirty seconds. After thirty seconds the controller returns to OFF or last display. B. Check actuator, ATO pump, ATO board, wire connections and RTD.
Frypots won't top off.	<ul style="list-style-type: none"> A. Empty JIB. B. Crumb build up around sensor. C. Probe temperature lower than setpoint. D. Oil is too cold. E. Bad Connection F. ATO board power loss G. Failed transformer/harness H. ATO pump failed I. Failed ATO board. J. ATO lines/pump plugged 	<ul style="list-style-type: none"> A. Ensure JIB has oil. B. Clean crumbs from opening surrounding sensor. C. Check to see that fryer is heating. Fryer temperature must be at setpoint. Check probe resistance. If probe is bad, replace the probe. D. Ensure that the oil in the JIB is above 70°F (21°C). E. With the controller OFF, press the temperature button and ensure the ATO software version appears. If not, the connection between the AIF and the ATO board may be bad. Ensure the 6-pin CAN connectors are tight between AIF (J4 and J5) and ATO (J10) boards. F. Power to the ATO board has been cut off. Restore power to the board and clear any service required errors. G. Ensure transformer in ATO box is functioning properly. Check power from transformer to ATO board. Ensure all harnesses are plugged securely into place. H. Ensure pump is operational. Check voltage to pump. Replace the pump if defective. I. Check for proper voltages using the pin position chart found on page 1-17. If ATO found defective, replace ATO board and clear any errors. J. Clear the lines/pump.

Problem	Probable Causes	Corrective Action
<p style="text-align: center;">Controller displays SERVICE REQUIRED – ATO BOARD</p>	<p>A. Loose or bad fuse B. Bad Connection C. ATO Board power loss</p>	<p>A. Ensure fuse on right side of ATO box is secure and good. If the controller above the ATO box is missing power check the fuse below the component box.</p> <p>B. With the controller OFF, press the temperature button and ensure the ATO software version appears. If not, the connection between the AIF and the ATO board may be bad. Ensure the 6-pin CAN connectors are tight between AIF (J4 and J5) and ATO (J9 or J10) boards.</p> <p>C. Power to the ATO board has been cut off. Ensure there is correct voltage to the ATO transformer. Restore power to the board and clear any service required errors.</p>

1.11.2 ATO (Automatic Top-Off) Board Pin Positions and Harnesses

Connector	From/To	Harness #	Pin #	Function	Voltage	Wire Color
J8	RTI Add Solenoid	8074671	1	24VAC Ret	24VAC	Black
			2			
			3			
	ATO Pump Relay		4	24VAC Ret	24VAC	Black
			5			
			6			
			7			
	JIB Reset Switch		8	JIB Low Reset	16VDC	Black
	Bulk Fresh Oil Solenoid		9	24VAC	24VAC	Red
			10			
			11			
	ATO Pump Relay		12	24VAC	24VAC	Red
			13			
			14			
			15			
	JIB Reset Switch		16	Ground	16VDC	Red
J4 (Rear) / J5 (Front)	Transformer	8074553	1	24VAC Ret	24VAC	Orange
			2	24VAC		Blue
			3			
			4			
		5	12VAC Ret	12VAC	Red	
		6	12VAC		Brown	
	ATO 4 & 5 Battery Jumper	8074657	7	Jumper	Ohm	Black
			8	Jumper		Black
J1 - Vat #1 J2 - Vat #2 J3 - Vat #3	ATO RTD	8262569- Probe Kit, 8074845 – 28” Ext., 8074655 – 20” Ext.,	1	DV - Probe Ground	Ohm	White
			2	DV - Probe		Red
			3	FV - Probe Ground		White
			4	FV - Probe		Red
J6			1			
			2			
J10	Network Resistor (pins 2 & 3) or to next ATO Board (4 & 5 vat units)	8074552 (Network resistor), 8074546 to next ATO board	1	Ground		Black
			2	CAN Lo		Red
			3	CAN Hi		White
			4	5VDC+	5VDC	Black
			5	24VDC	24VDC	Red
			6	Ground		White
J9	AIF J5	8074547	1	Ground		Black
			2	CAN Lo		Red
			3	CAN Hi		White
			4	5VDC+	5VDC	Black
			5	24VDC	24VDC	Red
			6	Ground		White

1.11.3 Replacing the ATO board, ATO pump relay or Transformers

Disconnect the fryer from the electrical power supply. Locate the ATO box (see Figure 1 on page 12), behind the JIB (Jug In Box). Remove the cover to expose the transformers and relay (see Figure 2). Mark and unplug any wires or harnesses. Replace the defective component and reattach all wires or harnesses. Replace the cover. Once replaced, **CYCLE POWER TO ENTIRE FRYER SYSTEM.** See section 1.12.6 on page 1-23 to reset control power. Check software version and if necessary update the software. If a software update was necessary, follow the instructions to update the software in section 1.16.

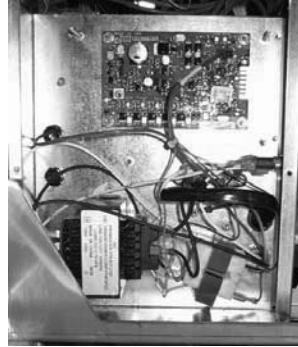

Figure 2

Press the temperature button on one of the FilterQuick™ controllers, with the controller in the OFF position, to verify software version of the ATO. If the version is not visible, the ATO may not be connected properly.

1.11.4 Replacing the ATO Pump or Solenoid

Disconnect the fryer from the electrical power supply. Locate the ATO pump (see Figure 4), behind the ATO box. Mark and unplug any wires or harnesses. Press up from the bottom on the quick disconnects to release the plumbing (see Figure 5). The plumbing can be pulled from the pump. Loosen the four nuts attaching the pump to the pump tray. Replace the defective component and reverse above steps. Once replaced, reconnect the power.



Figure 4



Figure 5

1.12 MIB (Manual Interface Board) Service Procedures

The MIB (Manual Interface Board) oversees and controls filtration. It receives and sends data over the CAN (Controller Area Network) to and from various sensors and controllers. It activates the filtration cycle, controlling when actuators should open and close.

The MIB controller is located inside the left cabinet (see Figure 6). In normal operation a cover hides the MIB controls and only the LED display is visible. The cover is held in place with three torx screws. In normal operation, an “A” is displayed for automatic mode. The MIB control board is useful for diagnostic purposes. It allows manual operation of both the actuators and filter pump without using the controller.

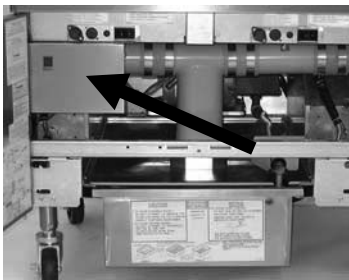

Figure 6: MIB controller cover.



Figure 7

Buttons and LED's

Manual – This button is used to toggle between auto and manual filtration mode. A corresponding LED is lit when in Manual mode. When pressed, a message will be sent to all vats, indicating the mode has changed.

The following buttons are inoperable in auto mode:

Select - This button is used to scroll through available vats, choosing one to be manually filtered.

Drain – This button is used to open and close the drain on the vat indicated on the display. It's embedded LED indicates the following activity:

Blink: Actuator is moving or awaiting a response from the AIF board.

Constant Illumination: Drain open.

No Illumination: Drain closed.

Return – This button is used to open and close the return valve on the vat indicated on the display. When pressed and held, it also turns on and off the pump. It's embedded LED indicates the following activity:

Blink: Actuator is moving or awaiting a response from the AIF board.

Constant Illumination: Return valve open.

No Illumination: Return valve closed.

1.12.1 Manually Draining, Refilling or Filtering using the MIB board

Press the manual/auto switch to set to manual. The LED on the manual key will illuminate and a vat number is displayed (see Figure 8).

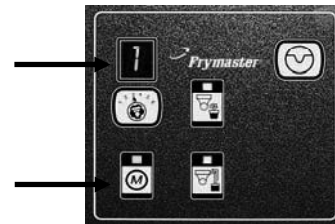

Figure 8

Press the vat selector switch to change vats (see Figure 9).

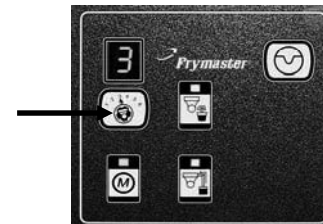

Figure 9

Pressing the drain or the return switch illuminates and activates the drain or return valve for the vat indicated. Pressing and holding the return switch while the return is open activates the filter motor and pump (see Figure 10).

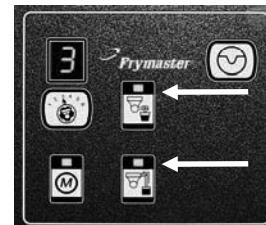

Figure 10

Pressing the manual/auto switch will return to automatic mode.

1.12.2 MIB (Manual Interface Board) Troubleshooting

Problem	Probable Causes	Corrective Action
<p>Auto filtration won't start.</p>	<ul style="list-style-type: none"> A. Filter pan out of position. B. Oil level too low. C. Ensure MIB board is not in manual mode. D. Ensure MIB cover is not damaged and pressing against buttons. E. Filter relay has failed. F. Filter motor thermal switch is tripped. 	<ul style="list-style-type: none"> A. Ensure filter pan is fully inserted into fryer. If the MIB board displays a “P” the pan is not fully engaged into the pan switch. B. Ensure the oil level is above the top oil level sensor. C. Ensure MIB board is in “A” automatic mode. D. Remove and replace cover and see if filtration will start. E. Replace filter relay with part number 8074482 24VDC relay. F. Press filter motor thermal switch.
<p>MIB display shows something other than an “A” or vat number.</p>	<p>An error has occurred and displayed character indicates error.</p>	<p>See MIB display diagnostics on page 1-23 for explanation.</p>
<p>No power present at the MIB board</p>	<p>Transformer has failed in left component box.</p>	<p>Check output on the left transformer in left component box; should read 24VAC. If not replace transformer.</p>
<p>MIB will not clear error.</p>	<p>Error remains in non-volatile memory.</p>	<p>Press and hold reset button in top right corner of MIB board for five seconds. The drain, return and manual/auto LEDs will illuminate and the MIB will reset and clear any remaining errors from memory. Allow 60 seconds to reset. If an error still exists, then another issue exists.</p>
<p>MIB indicates incorrect number of vats.</p>	<ul style="list-style-type: none"> A. Network is not terminated correctly. B. Wiring harnesses are loose or damaged. C. An AIF board issue. D. Locator pin issue. 	<ul style="list-style-type: none"> A. Ensure the CAN bus system is terminated at BOTH ENDS (on the controller connector J6 and on the ATO board connector J9) with a resistor equipped 6-pin connector. B. Unplug and reseat all wiring harnesses in CAN system. Resistance between pins 2 and 3 on the CAN network connectors should be 120 ohms. C. With the controller OFF, press the temperature button and check software version numbers on all FilterQuick™ controllers and ensure all display an AIF version. If an AIF version is missing, the AIF board may be missing power or bad. Check pins 5 and on J4 and J5 of the affected AIF board for proper voltage. D. The locator pin in J2 of the AIF board is either loose or in the incorrect position. See the charts on page 2-6 of this manual for proper pin position.

Problem	Probable Causes	Corrective Action
<p>MIB board alternating “E” and “vat number and side”.</p>	<p>Network error on the CAN bus communication.</p>	<p>A. Ensure the CAN bus system is terminated at BOTH ENDS (on the FilterQuick™ controller connector J6 and on the ATO board connector J10) with a resistor equipped 6-pin connector.</p> <p>B. With the controller OFF, press the temperature button and ensure the AIF version appears. If not, the 24V to the AIF boards may be missing. Ensure all 6-pin CAN connectors are tight between the FilterQuick™ controller (J6 and J7), MIB (J1 and J2), AIF (J4 and J5) and ATO (J10) boards.</p> <p>C. With the controller OFF, press the temperature button and ensure the ATO version appears. If not, check the CAN wire harness between the AIF board J4 or J5 and the ATO board J9 or J10. The ATO fuse on the right side of the ATO box may be loose or blown; the 110V to the ATO transformer may be missing or the transformer bad. The J4/J5 connector may be loose. Is the right controller functioning? If not the fuse below the contactor box may be loose or blown.</p> <p>D. Check to see if MIB has 24V on pins 5 and 6 of J2. Check to see if 24V is present on pins 5 and 6 of wire harness plugging into J4 or J5 of the first AIF board. If 24V missing, check the pins. Replace the harness if necessary.</p> <p>E. Check continuity between each color wire on the CAN connectors into J7 on the far right controller and J10 on back of the ATO board (black to black, white to white, and red to red), and ensure there is no continuity between different color wires (black to red, red to white, and white to black).</p> <p>F. Ensure black controller locator wires are connected from ground to correct pin position (see drawing 8051979 page 2-6).</p> <p>G. Ensure all boards have the corner ground wire attached and tightened.</p> <p>H. The locator pin in J2 of the AIF board is either loose or in the incorrect position. See the charts on page 2-6 of this manual for proper pin position.</p> <p>I. Bad MIB and/or AIF board.</p> <p>J. Broken resistor lead. Unwrap the resistor leads and check ends.</p>

1.12.3 MIB (Manual Interface Board) Pin Positions and Harnesses

Connector	From/To	Harness #	Pin #	Function	Voltage	Wire Color
J1	Controller J7	8074546	1	Ground		Black
			2	CAN Lo		Red
			3	CAN Hi		White
			4			
			5			
			6			
J2	AIF J5	8074850	1	Ground		Black
			2	CAN Lo		Red
			3	CAN Hi		White
			4	5VDC+	5VDC	Black
			5	24VDC	24VDC	Red
			6	Ground		White
J5	Transformer	8075800 Bulk 8075780 Non-Bulk	1	24VAC	24VAC	Black
	Filter Relay		2	24VAC Ret		White
				3	Pump Motor	24VDC
	4			Pump Motor	Green	
	Bulk Open Switch		5			
			6			
	Bulk Closed Switch		7	Open Switch +		Black
			8	Closed Switch +		Red
	Pan Switch		9			
			10			
			11	Pan Sw +	24VDC	Black
			12	Pan Sw -		Red
	Bulk Open Switch		13			
			14			
	Bulk Closed Switch		15	Ground -		White
			16	Ground -		Green
J6	To Bulk connection in rear of fryer	8075789	1	From bulk oil transformer	24VAC	Black
			2	Common Return		White
			3	To bulk oil fresh oil pump relay	24VAC	Green
			4			
			5			
			6			
			7			
			8	From bulk oil "Waste Tank Full Sensor" Test Pins 2 to 8	24VAC – Full 0VAC – Not Full	Red

1.12.4 MIB (Manual Interface Board) Display Characters

A – Auto Mode – Auto Filtration enabled.

E – Drain or return valve is not in desired state. The display will alternate between **E** and the corresponding vat number. Ensure the actuator is plugged in and an error does not exist.



– Three horizontal lines indicate the AIF temperature sensor did not detect that the vat was full during auto filtration.

n – Network Error - An “n” displays for 10 seconds if no communication is received from the cooking controller within ten seconds after a power on or MIB reset.

P – Pan Switch – Filter pan is improperly seated. Filtration is suspended.

r – Reset Switch - Reset the vat closes all of the valves on the vat. If displayed for some time, there is probably a problem with the board.

1 – 5 – Numbers which correspond to the vats with either an “L” indicating the left side of a split vat or “r” indicating the right side of a split vat or a full vat. These numbers are displayed in manual mode.

1.12.5 Replacing the MIB Board

Disconnect the fryer from the electrical power supply. Remove the torx screws from the MIB cover, exposing the MIB board (see Figure 11). Removing the screw at top center lets the MIB board hinge down. Carefully remove the plugs on the rear of the board (see Figure 12). Replace with a new MIB board and reverse steps to reassemble. Once replaced, **CYCLE POWER TO ENTIRE FRYER SYSTEM**. See next section to reset control power. Check software version # and if necessary update the software. If a software update was necessary, follow the instructions to update the software on in section 1.16 ensuring the MIB reset button is pressed and held for five seconds at the end of the update to update the MIB.



Figure 11

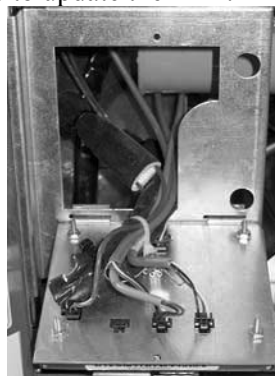

Figure 12

1.12.6 Control Power Reset Switch

The control power reset switch is a momentary rocker switch located behind the control box (see Figures 13 and 14) above the JIB that resets all power to all the controllers and boards in the fryer. It is necessary to reset all power after replacing any controller or board. Press and hold the switch for at least ten seconds when resetting the control power to ensure power has sufficiently drained from boards.



Figure 13

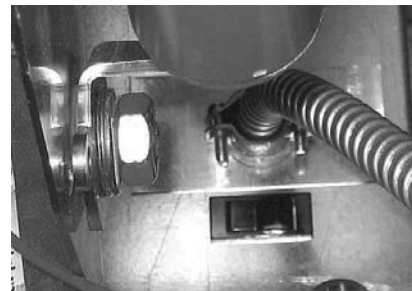

Figure 14 (Rear view of Control Box)

1.13 Bulk Service Issues

1.13.1 Bulk MIB Tests

The FilterQuick™™ fryer will **ONLY** operate with bulk systems that have the three-pole float switch. If the float switch is the older two-pole switch, call the bulk oil provider. These float switches are polarity specific which may short to ground and damage an MIB board.

Normal measurements (MIB J6 8-pin connector with everything connected)

AC voltage measurements:

Pin 1 to Pin 2 - 24 VAC.

Pin 2 to Pin 8 - 24 VAC when waste tank is full, 0 VAC when it is not full.

Pin 2 to Pin 3 - 24 VAC when RTI fill pump is on, 0 VAC when it is off.

Using the bulk test box, PN# 108-0716 allows a quick and easy way to check the 24VAC, the waste full switch and when the bulk fresh oil pump is operating.

Troubleshooting

All return and drain valves should be closed and pump should be off while the MIB is resetting. If any of the valves or the pump is on during reset, the MIB board is bad or wires are shorted.

Bulk fresh oil pump is not operating or JIB is not filling:

See page 1-25 to ensure that no other function is taking priority over adding oil to jug.

1. Reset the power; wait 60 seconds and see if the valve opens.

With the JIB button pressed:

2. Voltage at MIB board from Pin 1 to Pin 2 should be 24 VAC; if not, check connections from bulk fresh oil pump 24VAC transformer and check transformer.
3. Voltage at MIB board from Pin 1 to Pin 3 should be 24 VAC when filling JIB or vat; if not, the MIB board is bad or wires to pump relay are shorted or both.
4. Voltage at Add pump relay should be 24 VAC; if not, check wiring from MIB board. The relay is located at the fresh oil tank pump system.
5. Check voltage at ATO board on J8. Pin 9 to Pin 1 should be 24 VAC with the orange button pressed.

Waste full signal:

Pin 2 to Pin 8 should be 24 VAC when full, 0 VAC when not full; if no voltage level change, the connection from bulk oil waste switch or MIB board is bad.

1.13.2 Bulk Wiring

BULK OIL WIRING

TESTING BETWEEN PINS 1 & 4
 9-PIN FEMALE PLUG SHOULD READ:
 24VAC WHEN BULK TANK IS FULL
 0 VAC WHEN BULK TANK IS EMPTY

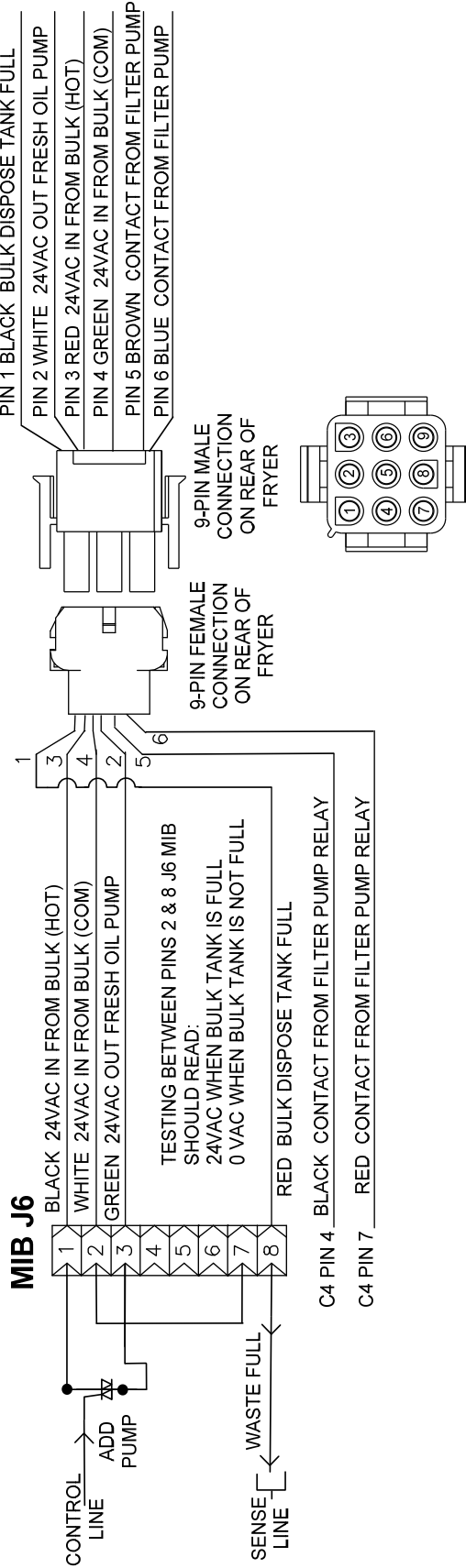

1.13.3 Frymaster FilterQuick™ Fryer and Bulk Oil System Plumbing Schematic

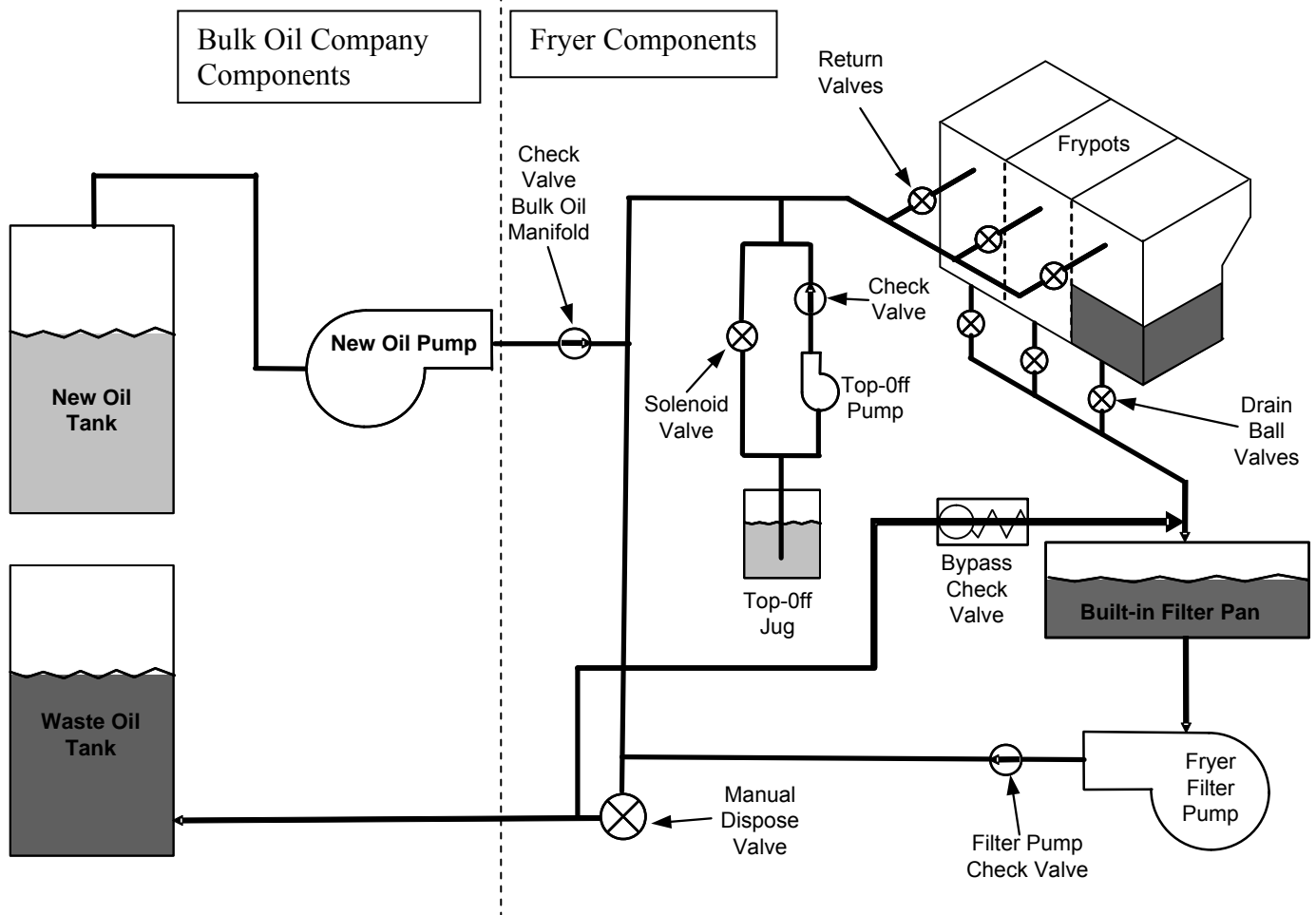

1.13.4 Bulk Oil Test Quick Reference

DISPOSE TO WASTE, REFILL VAT FROM BULK:

1. Hold down "Filter" button until controller beeps twice.
2. Scroll to "Dispose" using "Right Arrow" button then press "✓" button.
3. "Dispose? Yes/No" is displayed.*
4. Press "Yes" to dispose of oil in pot.
5. "Start Dispose" is displayed with blinking LED.
6. Pull the drain handle
7. "Draining" followed by "Flushing" is displayed.
8. "Vat Empty? Confirm" is displayed.
9. Press "Confirm".
10. "Close Drain" is displayed with blinking LED.
11. Push the drain handle in towards the fryer.
12. "Open Dispose Valve" is displayed.
13. Open dispose valve by pulling completely forward to start disposal.
14. "Disposing" is displayed for four minutes.
15. "Remove Filter Pan" is displayed.
16. Slide the filter pan slightly out of the fryer.
17. "Is Pan Empty? Yes No" is displayed.
18. Press "Yes" if filter pan is empty. Select "No" if pan still has oil in it.

19. "Insert Filter Pan" is displayed.
 20. Insert the filter pan.
 21. "Close Dispose Valve" is displayed.
 22. Close dispose valve ensuring the handle is pushed completely towards the fryer.
 23. "Fill Vat From Bulk? Yes/No" is displayed.
 24. Press "Yes".
 25. "Press and Hold Yes Arrow to Fill" alternating with "Yes" is displayed.
 26. Hold down "Yes" to fill pot to desired level.
 27. "Filling" is displayed while button is depressed.
 28. "Continue Filling Yes/No" is displayed
 29. Press "Yes" to continue filling or "No" to Exit program.
- *NOTE:** If the waste tank is full, the controller displays "Waste Tank Full." Call bulk oil provider.

DISPOSE TO WASTE:

1. Hold down "Filter" button until controller beeps twice.
 2. Scroll to "Dispose" using "Right Arrow" button then press "✓" button.
 3. "Dispose? Yes/No" is displayed.*
 4. Press "Yes" to dispose of oil in pot.
 5. "Start Dispose" is displayed with blinking LED.
 6. Pull the drain handle
 7. "Draining" followed by "Flushing" is displayed.
 8. "Vat Empty? Confirm" is displayed.
 9. Press "Confirm".
 10. "Close Drain" is displayed with blinking LED.
 11. Push the drain handle in towards the fryer.
 12. "Open Dispose Valve" is displayed.
 13. Open dispose valve by pulling completely forward to start disposal.
 14. "Disposing" is displayed for four minutes.
 15. "Remove Filter Pan" is displayed.
 16. Slide the filter pan slightly out of the fryer.
 17. "Is Pan Empty? Yes No" is displayed.
 18. Press "Yes" if filter pan is empty. Select "No" if pan still has oil in it.
 19. "Insert Filter Pan" is displayed.
 20. Insert the filter pan.
 21. "Close Dispose Valve" is displayed.
 22. Close dispose valve ensuring the handle is pushed completely towards the fryer.
 23. "Fill Vat From Bulk? Yes/No" is displayed.
 24. Press "No" if you wish to leave pot empty and exit.
- *NOTE:** If the waste tank is full, the controller displays "Waste Tank Full." Call bulk oil provider.

FILL VAT FROM BULK:

1. Hold down "Filter" button until controller beeps twice.
2. Scroll down to "Fill Vat from Bulk" using "Right Arrow" button then press "✓" button.
3. "Fill Vat from Bulk? Yes/No" is displayed.
4. Press "Yes".
5. "Press and Hold Yes to Fill / Yes" is displayed.
6. Press and hold down "YES" to fill pot to desired level.
7. "Filling" is displayed during fill.

8. Release button to stop filling.
9. “Continue Filling? Yes/No” is displayed.
10. Press “NO” to exit.

FILL JUG FROM BULK:*

1. When “Top Off Oil Empty” is displayed, the top-off jug is empty.
2. To refill jug press and hold the orange reset button above the jug until the jug is full.
3. Release the button to stop filling.

***NOTE: The jug may not fill if any of the following are in progress:**

If FILTER NOW? YES/NO, CONFIRM YES/NO, or SKIM VAT is displayed, the fill jug button is disabled until either a filter is complete or until no is chosen.

The system also checks these conditions. The following must be met before jug fill is allowed.

- Solenoid closed
- Orange fill button pressed longer than 3 sec.
- Waste valve closed
- Filter Now? Yes/No, Confirm Yes/No, or Skim Vat cannot be displayed
- System power cycle (all boards – controllers, MIB, AIF and ATO) after changing setup from JIB to Bulk (use momentary reset). Ensure reset is pressed and held for at least ten seconds.
- No filtration or other filter menu selection can be in process.

Other factors that may not allow fill jug from bulk –

- Defective solenoid
- Defective switch
- Bulk fresh oil pump issue
- Bulk fresh oil relay issue

If using multiple fryer systems that are both attached to the bulk fresh oil system, they may not be able to fill both units at the same time if they have a bulk fresh oil unit with a single head. Some bulk fresh oil units have dual heads which can fill more than one fryer simultaneously.

1.14 AIF (Automatic Intermittent) Filtration Service Procedures

The AIF (Automatic Intermittent Filtration) board controls the actuators that open and close the drain and return valve. The AIF boards are located inside a protective housing under each frypot (see Figure 13).

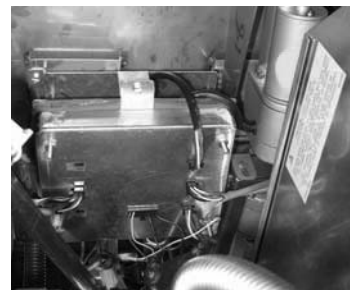

Figure 13

1.14.1 AIF Troubleshooting

Problem	Probable Causes	Corrective Action
<p>Actuator doesn't function.</p>	<p>A. No power to the AIF board. B. Actuator is unplugged. C. AIF board failure. D. Actuator readings are out of tolerance. E. Actuator is bad</p>	<p>A. Check pins 5 and 6 of J2 at the MIB board. Should read 24VDC. Check voltage on pins 5 and 6 at the other end of harness and ensure 24VDC is present. Continue to check pins 5 and 6 for 24VDC on plugs J4 and J5 on the AIF boards. B. Ensure the actuator is plugged into the proper connection (J1 for FV return, J3 for DV return and J6 for FV drain and J7 for DV drain). C. Check power on the connector of the problem actuator while trying to manually open or close an actuator. Pins 1 (Black) and 4 (White) should read +24VDC when the actuator is opening. Pins 2 (Red) and 4 (White) should measure -24VDC when the actuator is closing). If either voltage is missing, the AIF board is likely bad. Test the actuator by plugging into another connector. If the actuator operates, replace the board. D. Check resistance of the potentiometer between pin 3 (blue wire) and pin 4 (gray/white wire). Closed should read 0-560Ω. Open should read 3.8K Ω – 6.6K Ω. E. If proper voltages are present at the connector and actuator doesn't operate, reset power to the fryer. If it still doesn't operate replace the actuator.</p>
<p>Actuator functions on wrong vat.</p>	<p>A. Actuator plugged into wrong connector. B. Locator pin is in wrong position.</p>	<p>A. Ensure the actuator is plugged into correct connection (J1 for FV return, J3 for DV return and J6 for FV drain and J7 for DV drain). B. Ensure the locator pin is in proper position in plug J2. See table B on page 2-6.</p>

1.14.2 AIF (Auto Intermittent Filtration) Actuator Board Pin Positions and Harnesses

Connector	From/To	Harness PN	Pin #	Function	Voltage	Wire Color	
J1	FV Return Actuator	N/A	1	Ret + (Open)	24VDC	Black	
			2	Ret – (Closed)	24VDC	Red	
			3	Ret Position		Blue	
			4	Ground		White	
J2	FV AIF RTD		1	Ground		White	
	DV AIF RTD		2	FV - Temp		Red	
			3	Ground		White	
			4	DV - Temp		Red	
			5				
			6				
			7				
			8				
			9				
			10				
			Locator Pin	11	Locator Vat #5		Black
				12	Locator Vat #4		
				13	Locator Vat #3		
				14	Locator Vat #2		
				15	Locator Vat #1		
			Locator	16	Locator Signal		Black
J3	DV Return Actuator	N/A	1	Ret + (Open)	24VDC	Black	
			2	Ret – (Closed)	24VDC	Red	
			3	Ret Position		Blue	
			4	Ground		White	
J4	MIB J2 or AIF J5	8074547 AIF Board Communication and Power	1	Ground		Black	
			2	CAN Lo		Red	
			3	CAN Hi		White	
			4	5VDC+	5VDC	Black	
			5	24VDC	24VDC	Red	
			6	Ground		White	
J5	AIF J4 or ATO J10	8074547 AIF Board Communication and Power	1	Ground		Black	
			2	CAN Lo		Red	
			3	CAN Hi		White	
			4	5VDC+	5VDC	Black	
			5	24VDC	24VDC	Red	
			6	Ground		White	
J6	FV Drain Actuator	N/A	1	Drain + (Open)	24VDC	Black	
			2	Drain – (Closed)	24VDC	Red	
			3	Drain Position		Blue	
			4	Ground		White	
J7	DV Drain Actuator	N/A	1	Drain + (Open)	24VDC	Black	
			2	Drain – (Closed)	24VDC	Red	
			3	Drain Position		Blue	
			4	Ground		White	

1.14.3 Replacing an AIF (Automatic Intermittent Filtration) board

Disconnect the fryer from the electrical power supply. Locate the AIF board to be replaced under a frypot. Mark and unplug the harnesses. The AIF board assembly is held in place with one screw in the front of the assembly (see Figure 14). Remove the screw and the front of the assembly drops down (see Figure 15) and the back tab slides out of the bracket attached to the frypot (see Figure 16). Reverse steps to reassemble, ensuring that the new AIF assembly slides into the slot in the rear of the bracket. Once complete, **CYCLE POWER TO ENTIRE FRYER SYSTEM**. See section 1.12.6 on page 1-23 to reset control power. Check software version # and if necessary update the software. If a software update was necessary, follow the instructions to update the software in section 1.16.

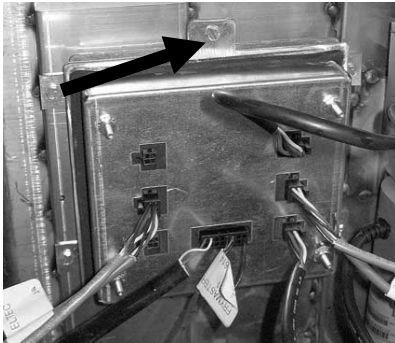

Figure 14

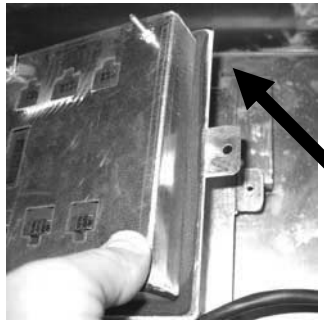

Figure 15

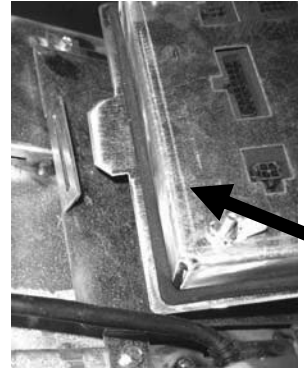

Figure 16

1.14.4 Replacing a Rotary Actuator

Disconnect the fryer from the electrical power supply. Locate the actuator to be replaced and mark and unplug the actuator. The actuators are held in place by two hex key screws. Loosen the 3/32" hex key screws. It may be necessary to remove a gas line to the burner when removing a drain actuator. Remove the actuator from the valve stem. Align the actuator with the valve stem and attach the new actuator. Tighten the two hex key screws. Reconnect power and test the actuator.

NOTE: Rotary actuators have two different part numbers, which are mirror images of each other that correspond to their mounting position.

1.15 FilterQuick™ Controller Service Procedures

1.15.1 FilterQuick™ Controller Troubleshooting

Problem	Probable Causes	Corrective Action
<p>No Display on Controller.</p>	<p>A. Controller not turned on. B. No power to the fryer. C. Power switch turned off. D. Loose fuse holder. E. Controller has failed. F. Damaged controller wiring harness. G. Power supply component or interface board has failed.</p>	<p>A. Press the ON/OFF switch to turn the controller on. B. This fryer may have two cords: a controller power cord and a main power cord. If the controller cord is not plugged in, the controller will not activate. Verify controller power cord is plugged in and that circuit breaker is not tripped. C. Some fryers have a rocker power switch inside the cabinet below the controller. Ensure the switch is turned on. D. Ensure fuse holder is screwed in properly. E. Swap the controller with a controller known to be good. If controller functions, replace the controller. F. Swap with a harness known to be good. If controller functions, replace the harness. G. If any component in the power supply system (including the transformer and interface board) fail, power will not be supplied to the controller and it will not function.</p>
<p>Controller locks up.</p>	<p>Controller error.</p>	<p>Remove and restore power to the controller.</p>
<p>Controller display shows <i>FILTER BUSY</i> or <i>WAIT FOR FILTER</i>.</p>	<p>A. Another filtration cycle is still in process. B. Controller error.</p>	<p>A. Wait until the previous filtration cycle ends to start another filtration cycle or until the MIB board has reset. This may take up to one minute. B. If filter busy is still displayed with no activity, ensure the filter pan is empty and remove and restore ALL power to the fryer.</p>
<p>Controller display shows <i>RECOVERY FAULT</i>.</p>	<p>Recovery time exceeded maximum time limit for two or more cycles.</p>	<p>Silence the alarm by pressing the ✓ button. Check that fryer is heating properly. Maximum recovery for electric is 1:40. If this error continues to appear call your FAS.</p>
<p>Controller displays <i>CALL TECH</i></p>	<p>Typically shown during software update. Also may be that parameter data has been corrupted or lost.</p>	<p>Press the FILTER button to bypass and continue.</p>
<p>Controller displays <i>SERVICE REQUIRED</i> followed by the error .</p>	<p>An error has occurred.</p>	<p>Press YES to silence alarm. The error is displayed three times. See list of issues in section 1.14.5. Fix issue. The controller displays SYSTEM ERROR FIXED? YES/NO. Press YES and follow prompts. Pressing NO will allow the fryer to cook in most cases, but error will be redisplayed every 15 minutes.</p>
<p>Controller displays <i>ERROR RM SDCRD</i></p>	<p>Defective SD Card</p>	<p>Replace card with another card.</p>
<p>Controller display is in wrong temperature scale (Fahrenheit or Celsius).</p>	<p>Incorrect display option programmed.</p>	<p>See section 1.15.2 on page 1-34 to change temperature scale.</p>

Problem	Probable Causes	Corrective Action
Controller displays CHANGE FILTER PAPER.	Filter error has occurred, filter paper clogged, 24 hour filter pad change prompt has occurred or change filter paper was ignored on a prior prompt.	Change the filter paper and ensure the filter pan has been removed from the fryer for a minimum of 30 seconds. Do NOT ignore CHANGE FILTER PAPER prompts.
Controller displays INSERT PAN.	A. Filter pan is not fully inserted into fryer. B. Missing filter pan magnet. C. Defective filter pan switch.	A. Pull filter pan out and fully reinsert into fryer. B. Ensure the filter pan magnet is in place and if missing replace. C. If the filter pan magnet is fully against the switch and controller continues to display INSERT PAN , switch is possibly defective.
Controller displays HOT-HI-1.	Frypot temperature is more than 410°F (210°C) or, in CE countries, 395°F (202°C).	This indicates that the vat temperature has exceeded certain parameters and has discontinued heating. It is also displayed during a high limit test.
Controller displays HI-LIMIT.	Controller in high-limit test mode.	This is displayed only during a test of the high-limit circuit and indicates that the high-limit has opened properly.
Controller displays vat temperature alternating with MLT-CYCL.	Frypot temperature is below 180°F (82°C).	This display is normal when the fryer is first turned on while in the melt cycle mode. To bypass the melt cycle press the “COOL” button. The controller displays EXIT MELT? alternating with YES NO . Press the YES button to exit melt. If the display continues, the fryer is not heating.
Controller displays TEMP PROBE FAILURE.	A. Problem with the temperature measuring circuitry including the probe. B. Damaged controller wiring harness or connector.	A. This indicates a problem within the temperature measuring circuitry. Check resistance of probe, if faulty replace probe. B. Swap the controller wiring harness with one known to be good. If problem is corrected, replace the harness.
FILTER and CLEAN AND FILER won't start.	Temperature too low.	Ensure fryer is at setpoint before starting these functions.
Controller displays HEATING FAILURE.	Failed controller, failed interface board, open high-limit thermostat.	Turn off the vat with the issue. The error is displayed if the fryer loses its ability to heat oil. It is also displayed when the oil temperature is above 450°F (232°C) and the high-limit thermostat has opened, halting the heating of the oil.
Controller will not go into program mode or some buttons do not actuate.	Failed controller.	Replace controller
Controller displays HI 2 BAD.	Controller in high-limit test mode.	This is displayed during a test of the high-limit circuit to indicate if the high-limit has failed.
Controller displays HELP HI-2 or HIGH LIMIT FAILURE.	Failed high-limit.	This is displayed to indicate the high-limit has failed.

Problem	Probable Causes	Corrective Action
Controller display shows software for only controller or MIB but not all boards.	Loose or damaged harness	Check that all harnesses between controllers, MIB, AIF and ATO are secure. Ensure 24VDC is present on pins 5 & 6 of J2 on MIB board and on J4 or J5 of AIF board. Check for loose or broken pins/wires. If the problem persists, swap out controller from one bank to another and cycle power on the fryer.
Controller display shows <i>LOW TEMP</i>, heating indicator cycles on and off normally but fryer does not heat.	A. Three phase power cord unplugged or circuit breaker is tripped. B. Blown fuse C. Failed controller. D. Damaged controller wiring harness. E. Open connection in high-limit circuit.	A. Ensure all cords are fully seated in the receptacles, locked into place and that circuit breakers are not tripped. B. Check the three amp fuse on front of control box. C. Replace controller. D. Replace controller wiring harness. E. Check high limit circuit starting at the control box connector working to the high-limit.
Controller display shows <i>IS VAT FULL? YES NO</i>.	A filter error has occurred due to dirty or clogged filter pad or paper, clogged filter pump, filter pump thermal overload, improperly installed filter pan components, worn or missing O-rings, cold oil or an actuator problem.	Follow the steps in the flowchart in section 1.15.5.
Fryer filters after each cook cycle.	Filter after setting incorrect or software update issue.	Overwrite the filter after setting by re-entering the filter prompt value in Product Setup. Press and hold the ✓ button until <i>MAIN MENU</i> changing to <i>PRODUCT SETUP</i> is displayed. Press the ✓ button. <i>ENTER CODE</i> is displayed. Enter 1650 . Scroll down to Filter Prompt and set value. Ensure that the right arrow is pressed after entering the value to save the setting.

1.15.2 FilterQuick™ Controller Useful Codes

To enter any of the following codes: Press and hold the ✓ button until *MAIN MENU* changing to *PRODUCT SETUP* is displayed. Press ► to scroll to *TECH MODE* and press the ✓ button. *ENTER CODE* is displayed. Enter a code number below to perform a function.

- **Clear E-Log, Clear Passwords, Change Lane Count, Change Hold Mode and Perform High Limit Test, – Enter 3000.**
- **Reset Factory Menu - Enter 3322.** The controller display flashes and quickly counts from 1-40 and switches to *OFF*. (**NOTE:** This will delete any hand-entered menu items).
- **Change from F° to C° - Enter 1658.** The controller displays *OFF*. Turn the controller on and check temperature to see the temperature scale. If the desired scale is not displayed, repeat.
- **Reset RECOVERY FAULT CALL SERVICE – Enter 0042.**

The following codes require the removal and reinsertion of the J3 locator plug on the rear of the controller before entering the code.

- **Reset CALL TECH Message** - Disconnect board locator plug (J3). Reinsert plug. Enter **1000**. Controller display switches to **OFF**. Remove and then restore power to the controller using the 20-pin plug. If this error is displayed, replace the controller.
- **Reset BADCRC Message** - Disconnect board locator plug (J3). Reinsert plug. Enter **9988**. Controller display switches to **OFF**. Remove and then restore power to the controller using the 20-pin plug. Replace the controller.

PASSWORDS

- **Product Setup Mode:** Press and hold the ✓ button until **MAIN MENU** changing to **PRODUCT SETUP** is displayed. Press the ✓ button. **ENTER CODE** is displayed. Enter **1650**.
- **Vat Setup Mode:** Press and hold the ✓ button. **MAIN MENU** changing to **PRODUCT SETUP** is displayed. Press ► to scroll to **VAT SETUP** and press ✓. **ENTER CODE** is displayed. Enter **1656**.
- **Tech Mode:** Press and hold the ✓ button until **MAIN MENU** changing to **PRODUCT SETUP** is displayed. Press ► to scroll to **TECH MODE** and press ✓. **TECH MODE** is displayed. Press the ✓ button. **ENTER CODE** is displayed. Enter **3000** or a code from above.

1.15.3 Service Required Errors

A **SERVICE REQUIRED** error alternating with **YES** displays on the controller. After **YES** is pressed the alarm is silenced. The controller displays an error message from the list below three times with the location of the error. Then the controller displays **SYSTEM ERROR FIXED? YES/NO**. Press **YES** if fixed. If **NO** is chosen the system returns to cook mode for 15 minutes then redisplay error until issue is fixed.

1.15.4 Error Log Codes

Refer to page 1-38, Vat Setup for access to the E-log. The ten most recent errors are listed from A-J, with A being the most recent error.

CODE	ERROR MESSAGE	EXPLANATION
E03	ERROR TEMP PROBE FAILURE	Temp probe reading out of range
E04	HI 2 BAD	High limit reading is out of range.
E05	HOT HI 1	High limit temperature is past more than 410°F (210°C), or in CE countries, 395°F (202°C)
E06	HEATING FAILURE	A component has failed in the high limit circuit such as controller, interface board, contactor or open-high limit.
E07	ERROR MIB SOFTWARE	Internal MIB software error
E08	ERROR ATO BOARD	MIB detects ATO board connection lost; ATO board failure
E09	ERROR PUMP NOT FILLING	Oil not returning to vat quickly. Possible problems: dirty pad, bad or missing O-rings, tripped or defective filter pump, actuators or linkage.
E10	ERROR DRAIN VALVE NOT OPEN	Drain valve failed to open; the valve's position is unknown.
E11	ERROR DRAIN VALVE NOT CLOSED	Drain valve failed to close; the valve's position is unknown.
E12	ERROR RETURN VALVE NOT OPEN	Return valve failed to open; the valve's position is unknown.
E13	ERROR RETURN VALVE NOT CLOSED	Return valve failed to close; the valve's position is unknown.
E14	ERROR AIF BOARD	MIB detects AIF missing; AIF board failure
E15	ERROR MIB BOARD	Cooking controller detects MIB connections lost; Check software version on each controller. If versions are missing, check CAN connections between each controller; MIB board failure
E16	ERROR AIF PROBE	AIF RTD reading out of range
E17	ERROR ATO PROBE	ATO RTD reading out of range
E19	CAN TX FULL	Connection between controllers lost
E20	INVALID CODE LOCATION	SD card removed during update
E21	FILTER PAPER PROCEDURE ERROR (Change Filter Paper)	25 hour timer has expired or dirty filter logic has activated
E22	OIL IN PAN ERROR	The MIB has reset the oil in pan flag.
E23	CLOGGED DRAIN (Gas)	Vat did not empty during filtration
E24	OIL SENSOR FAILED (Gas)	Oil is back sensor failed.
E25	RECOVERY FAULT	Recovery time exceeded maximum time limit.
E27	LOW TEMP ALARM	Oil is approximately 35°F (19.4°C) below setpoint.
E28	HIGH TEMP ALARM	Oil temperature has risen 40°F (22.2°C) higher than setpoint. If temperature continues to rise, the high limit will shut the burner off when temperature reaches 425°F (218°C) Non-CE or 395°F (202°C) CE.
E70	OQS TEMP HIGH	Oil temperature is too high for a valid OQS reading. Filter at a temperature between 300°F (149°C) and 375°F (191°C).
E71	OQS TEMP LOW	Oil temperature is too low for a valid OQS reading. Filter at a temperature between 300°F (149°C) and 375°F (191°C).
E72	TPM RANGE LOW	The TPM is too low for a valid OQS reading. The incorrect oil type may be selected in the setup menu. The sensor may not be calibrated for the oil type. See oil type chart.
E73	TPM RANGE HIGH	The TPM reading is too high for a valid OQS reading. Dispose the oil.
E74	OQS ERROR	The OQS has an internal error. Power cycle the entire fryer battery. Check to see if OQS software version appears.
E75	OQS AIR ERROR	The OQS is detecting air in the oil. Check the O-rings and check/tighten prescreen filter to ensure no air is entering the OQS sensor.
E76	OQS ERROR	The OQS sensor has a communication error. Check connections to the OQS sensor. Power cycle the entire fryer battery.

1.15.5 FilterQuick™ Filter Error Flowchart

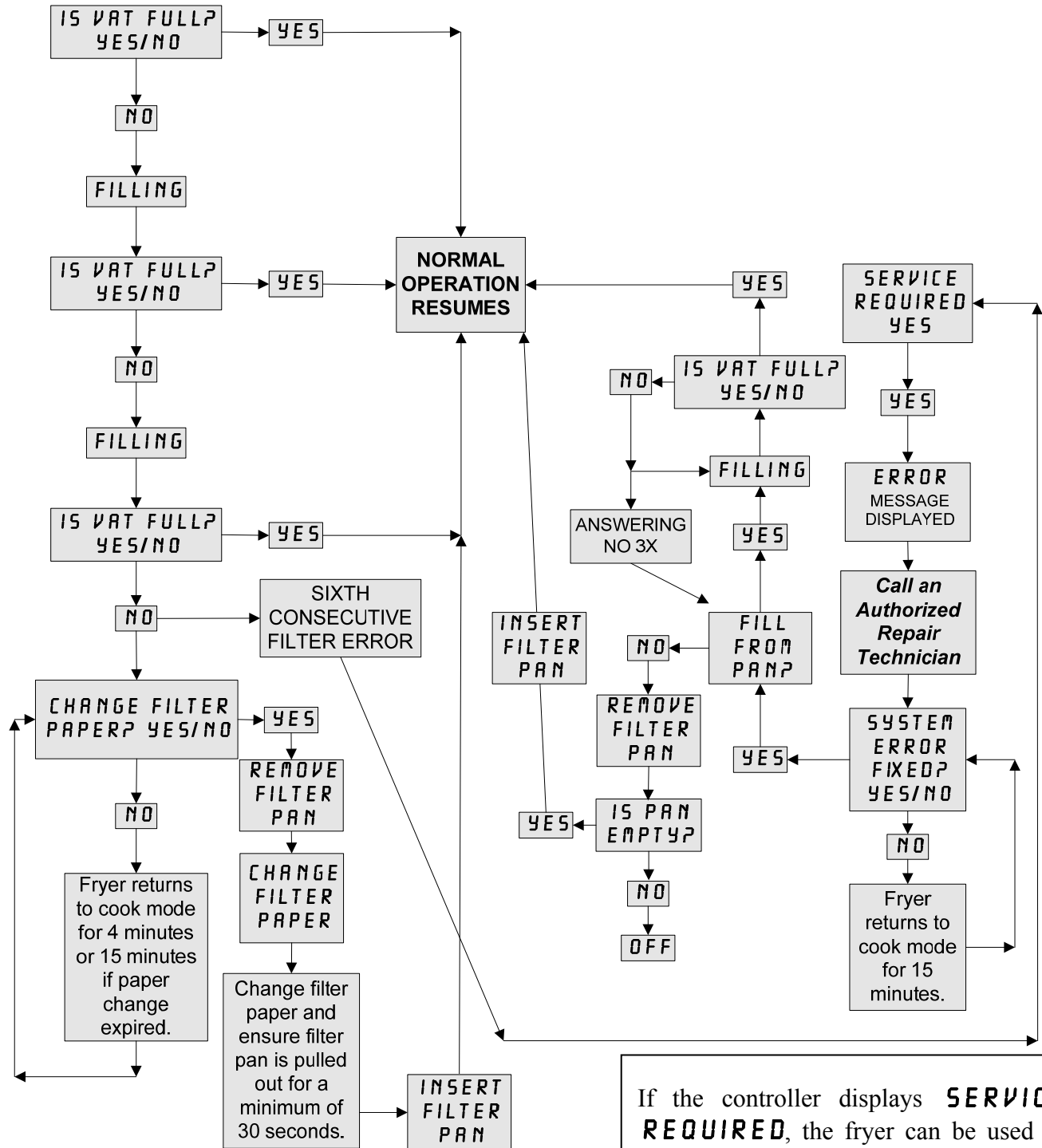

This chart follows the process of clearing a filtration issue. The prompt is displayed when any of the following occur:

1. a clogged filter pad,
2. a tripped or defective filter pump,
3. a leaky O-ring on the pick-up tube,
4. a failed drain valve/actuator, or
5. a failed return valve/actuator.

If the controller displays **SERVICE REQUIRED**, the fryer can be used in most cases by answering **NO** when the prompt for **SYSTEM ERROR FIXED? YES NO** is displayed. The message repeats every 15 minutes until the issue is repaired and error cleared by answering **YES** when **SYSTEM ERROR FIXED? YES NO** is displayed.

1.15.6 Menu Trees

1.15.6.1 FilterQuick™ Controller Setup Menu Tree

Main Menu and Tech Modes
 [With computer OFF, press and hold ✓(check) button 10 seconds, displays Main Menu - Product Setup]

Product Setup	1.6
[Enter 1650]	
Select Product	
Long Name	
Short Name	
Cooking Mode	
1 Time	
1 Tempr	
1 Sensitivity	
1 Alarm Time (Shake)	
1 Alarm Name (Shake)	
1 Alarm Mode (Shake)	
1 Alarm Tone (Shake)	
2 Alarm Time (Shake) Time entered here, produces a 3 rd alarm time.	
Filter Prompt	
Instant On	
Hold Time	
Load Standard (Load Default Product Menu)	
Vat Setup	1.4
[Enter 1656]	
System	1.4
Language	
2 nd Language	
Locale (CE or Non-CE)	
Energy (Gas or Elec)	
Type (Vat)	
System Volume (Sound Level)	
Tempr Format (F or C)	
Exit Melt Tempr	
Cool Mode Tempr	
Cool Mode Default	
Fresh Oil	
Waste	
Recovery Alarm	
Basket Lift	
Hold Time	
Time/Date.....	1.4
DST(Daylight Savings Time) Setup	1.4
Filter	1.4
Cooks til Filter	
Filter Lockout	
EOD Filter Timer	
EOD Filter Time	
Flushing Timer	
Clean (Hot or Cold)	
Clean Timer (Hot or Cold)	
Polish Lockout	
1 Polish Timer	
1 Polish Prompt Time	
1 Polish Delay Timer	
1 Polish Duration	
Enable Filters Percent	
1 Polish Start Tempr	
Clean and Filter Timer	
Clean and Filter Prompt Time	
Clean and Filter Delay Timer	
Clean and Filter Start Tempr	
OQS	3.1
OQS Type	
Display Type – Text / Number	
Discard Now	
Discard Soon	
Dispose Delay Timer	
E-Log List of last 10 error codes	1.4
Change Password	1.4
Tech Mode	
[Enter 3000]	
Clear E-Log	
Clear Passwords	
Lane Count	
Hold Mode	
Hi-Limit Test	
Polishing	1.10
Scan Mode.....	1.11

NOTE: Three alarm times are programmable. The steps for programming the 2nd alarm are just like the first. A third alarm prompt follows completion of the 2nd.

NOTE: If the lane count doesn't change, set the basket lift to disabled in Vat Setup.

1.15.6.2 FilterQuick™ Filter and Info Mode Menu Tree

Filter Menu 1.9

- [With computer OFF, press and hold FILTER button]**
- Dispose
 - (Dispose to SDU / Fill from JIB)
 - (Dispose to Bulk or Front / Fill from JIB)
 - (Dispose to Bulk / Fill from Bulk)
- Drain to Pan
- Clean (Hot [Boil Out] or Cold [Cold Soak])
 - (Dispose to SDU / Fill from JIB)
 - (Dispose to Bulk or Front / Fill from JIB)
 - (Dispose to Bulk / Fill from Bulk)
- Pan to Waste (Bulk only)
- Fill Vat from Pan
- Fill Vat from Bulk (Bulk only)

Filter Menu 1.9

- [With computer ON, press and hold FILTER button]**
- Filter
- Clean and Filter
- OQS (Oil Quality Sensor) (Available only if installed and enabled.)
- Dispose
 - (Dispose to SDU / Fill from JIB)
 - (Dispose to Bulk or Front / Fill from JIB)
 - (Dispose to Bulk / Fill from Bulk)
- Drain to Pan
- Pan to Waste (Bulk only)

Info Mode 1.5

- [Press and hold ✓(check) button]**
- Last Dispose Stats
- Daily Stats
- Selected Period Stats
- Last Load Stats
- TPM

1.15.7 FilterQuick™ Controller Board Pin Positions and Harnesses

Connector	From/To	Harness PN	Pin #	Function	Voltage	Wire Color	
J1	SD Card						
J2	Interface Board to Controller	8075165 SMT Controller to Interface Board Harness	1	12VAC In	12VAC	Black	
			2	Ground			
			3	12VAC In	12VAC		
			4	FV Heat Demand			
			5	V Relay	12VDC		
			6	DV Heat Demand			
			7	R/H B/L	12VDC		
			8	Analog Ground			
			9	L/H B/L	12VDC		
			10	ALARM			
			11	Sound Device	5VDC		
			12	ALARM			
			13	FV Probe			
			14	Common Probes			
			15	DV Probe			
			16				
			17				
18							
19							
20							
J3	Interface Board Ground to Controller	Controller Locator Harness	1	Vat #1		Black	
			2	Vat #2			
			3	Vat #3			
			4	Vat #4			
			5	Vat #5			
			6	Ground			
J4	Drain Switch and LED	1085672	1	Ground		Black	
			2	Push Pull Switch In		Red	
			3	Ground		Black	
			4	Drain Indicator LED		Red	
J6	Next Controller J7 or Network Resistor	8074546 Controller Communication Harness	1	Ground		Black	
			2	CAN Lo		Red	
			3	CAN Hi		White	
			4	5VDC+	5VDC	Green	
			5	24VDC	24VDC	Yellow	
			6	Ground		Brown	
J7	MIB J1 or previous Controller J6	8074546 Controller Communication Harness	1	Ground		Black	
			2	CAN Lo		Red	
			3	CAN Hi		White	
			4	5VDC+	5VDC	Green	
			5	24VDC	24VDC	Yellow	
			6	Ground		Brown	

1.15.8 OQS (Oil Quality Sensor) Troubleshooting

Problem	Probable Causes	Corrective Action
<p>No TPM results displayed.</p>	<p>A. Temperature too low or too high. B. Loose pre-screen filter. C. Missing, cracked or worn O-rings. D. Dirty filter paper. E. TPM too high. F. Error code.</p>	<p>Check the following items A-E and perform another OQS filter.</p> <p>A. Ensure the vat is at setpoint temperature. B. Inspect the pre-screen filter and ensure it is screwed in tightly. C. Inspect the O-rings on the filter pan and ensure they are both present and that they are not missing, cracked or worn. If so replace them. D. Ensure the filter paper is not clogged and clean filter paper is used. Did the vat refill the first time for the previous filter? If not change the filter paper. E. Dispose of the oil. F. Check error log for any OQS errors E70-76. See explanation and solution in section 1.15.4.</p>
<p>Controller does not display OQS software version.</p>	<p>A. Loose or damaged harness. B. Defective OQS sensor.</p>	<p>A. Check harnesses between controllers and OQS sensor are secure. Ensure 5VDC is present on pins 4 & 6 of J6 and J7 of the controller. Check for loose or broken pins/wires. If the problem persists, cycle power on the fryer. B. Defective OQS sensor.</p>

1.16 Loading and Updating Software Procedures

Updating the software takes approximately 30 minutes. The software only needs to be loaded in **ONE** controller and it will update **all** the controllers and boards in the system. To update the software, follow these steps carefully:

1. Switch all controllers to **OFF**. Press the temperature button to check current Controller/MIB/AIF/ATO software versions.
2. Remove the bezel and remove the two screws on the left side cover plate of the controller board.
3. With the controller folded down, insert the SD card, with the contacts facing down and the notch on the bottom right (see Figure 17 and 18), into the slot on the left side of the controller.
4. Once inserted, **UPGRADE IN PROGRESS** appears on the left display and **WAIT** on the right.
5. The display then changes to **CC UPDATING** on the left and the percentage completed appears on the right. The display counts up to 100 on the right, changing to a flashing **BOOT**. **DO NOT REMOVE THE CARD UNTIL THE DISPLAY PROMPTS TO DO SO IN STEP 8.**
6. Then **UPGRADE IN PROGRESS** is displayed on the left display and **WAIT** on the right again followed by **COOK HEX, MIB HEX, AIF HEX** ending with **ATO HEX** displayed on the left and the percentage complete on the right.
7. The display then changes to **REMOVE SD CARD** on the left and **100** on the right.
8. Remove the SD card using the fingernail slot on the top of the SD card.
9. Once the SD card is removed the display changes to **CYCLE POWER**.
10. Cycle the control power using the hidden reset switch behind the right control box. **ENSURE THE SWITCH IS HELD FOR 10 SECONDS. WAIT ANOTHER 20 SECONDS UNTIL THE MIB BOARD HAS FULLY RESET BEFORE CONTINUING.**
11. When the update is complete the controller displays **OFF**. The MIB display will remain blank while software is loading, changing to show the vat numbers. Once the LED's stop blinking, the MIB board will display **R**.
12. Cycle the control power using the hidden reset switch behind the right control box again. **ENSURE THE SWITCH IS HELD FOR 10 SECONDS. WAIT ANOTHER 20 SECONDS UNTIL THE MIB BOARD HAS FULLY RESET BEFORE CONTINUING.**
13. **With the controller displaying OFF, VERIFY software update by pressing the temperature button to check updated Controller/MIB/AIF/ATO version on each controller. IF ANY BOARDS DID NOT UPDATE, REPEAT THE PROCESS STARTING WITH STEP 3.**
14. Press the temperature button again.
15. Press the EXIT button to escape.
16. Once the software has been updated and the versions are correct, replace the cover and screws covering the SD card slot.
17. Reinstall the screws attaching the controllers and bezel by reversing steps 2 through 5.

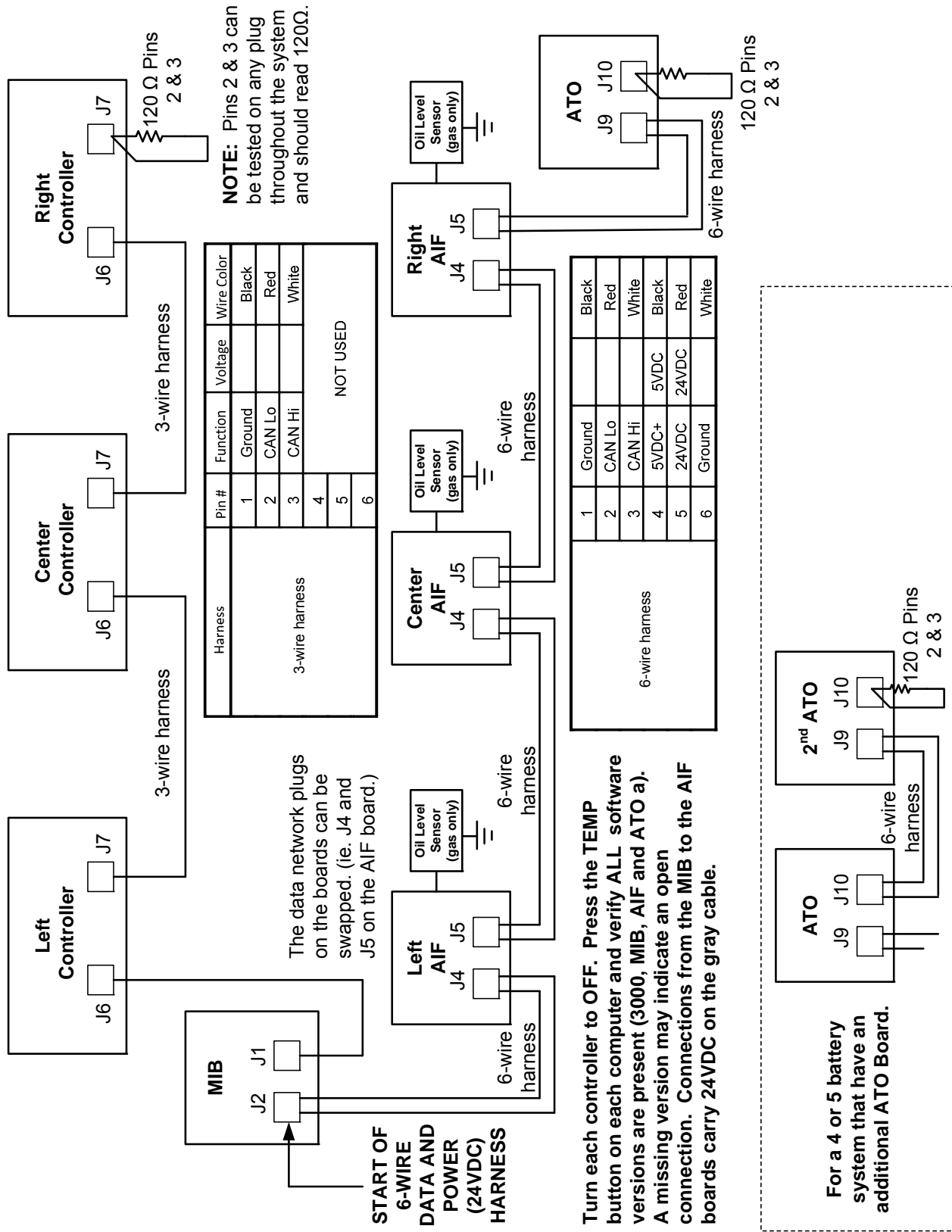

Figure 17



Figure 18

1.17 FILTERQUICK™ FQE30 Series Data Network Flowchart



1.18 Interface Board Diagnostic Chart

The following diagram and charts provide ten quick system checks that can be performed using only a multimeter.

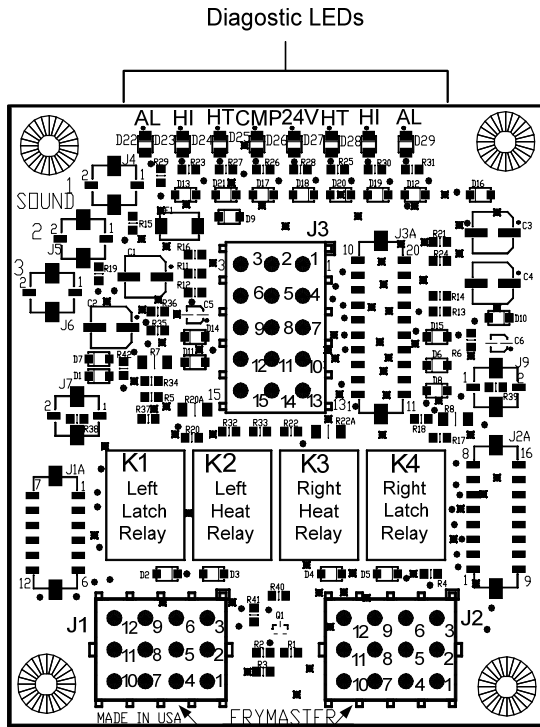

Diagnostic LED Legend	
CMP	indicates power from 12V transformer
24	indicates power from 24V transformer
HI (RH)	indicates output (closed) from right latch relay
HI (LH)	indicates output (closed) from left latch relay
HT (RH)	indicates output from right heat relay
HT (LH)	indicates output from left heat relay
AL (RH)	indicates output (open) from right latch relay
AL (LH)	indicates output (open) from left latch relay

PN 826-2260 (106-6664)

Test Points
J1 Left J2 Right

NOTE – Pin 1 is located in the bottom right corner of Both J1 and J2. These test points are ONLY for FILTERQUICK™ Series boards with J1 and J2 plugs on the front of the board.

Meter Setting	Test	Pin	Pin	Results
12 VAC Power	50 VAC Scale	3 of J2	1 of J2	12-16 VAC
24 VAC Power	50 VAC Scale	2 of J2	Chassis	24-30 VAC
*Probe Resistance (RH)	R X 1000 OHMS	11 of J2	10 of J2	See Chart
*Probe Resistance (LH)	R X 1000 OHMS	1 of J1	2 of J1	See Chart
High-Limit Continuity (RH)	R X 1 OHMS	9 of J2	6 of J2	0 - OHMS
High-Limit Continuity (LH)	R X 1 OHMS	6 of J1	9 of J1	0 - OHMS
Latch Contactor Coil (RH)	R X 1 OHMS	8 of J2	Chassis	3-10 OHMS
Latch Contactor Coil (LH)	R X 1 OHMS	5 of J1	Chassis	3-10 OHMS
Heat Contactor Coil (RH)	R X 1 OHMS	7 of J2	Chassis	11-15 OHMS
Heat Contactor Coil (LH)	R X 1 OHMS	4 of J1	Chassis	11-15 OHMS

*** Disconnect 15-Pin harness from the controller before testing the probe circuit.**

1.19 Probe Resistance Chart

<h3 style="text-align: center;">Probe Resistance Chart</h3> <p style="text-align: center;"><i>For use with fryers manufactured with Minco Thermistor probes only.</i></p>																	
F	OHMS	C	F	OHMS	C	F	OHMS	C	F	OHMS	C	F	OHMS	C			
60	1059	16	130	1204	54	200	1350	93	270	1493	132	340	1634	171			
65	1070	18	135	1216	57	205	1361	96	275	1503	135	345	1644	174			
70	1080	21	140	1226	60	210	1371	99	280	1514	138	350	1654	177			
75	1091	24	145	1237	63	215	1381	102	285	1524	141	355	1664	179			
80	1101	27	150	1247	66	220	1391	104	290	1534	143	360	1674	182			
85	1112	29	155	1258	68	225	1402	107	295	1544	146	365	1684	185			
90	1122	32	160	1268	71	230	1412	110	300	1554	149	370	1694	188			
95	1133	35	165	1278	74	235	1422	113	305	1564	152	375	1704	191			
100	1143	38	170	1289	77	240	1432	116	310	1574	154	380	1714	193			
105	1154	41	175	1299	79	245	1442	118	315	1584	157	385	1724	196			
110	1164	43	180	1309	82	250	1453	121	320	1594	160	390	1734	199			
115	1174	46	185	1320	85	255	1463	124	325	1604	163	395	1744	202			
120	1185	49	190	1330	88	260	1473	127	330	1614	166	400	1754	204			
125	1195	52	195	1340	91	265	1483	129	335	1624	168	405	1764	207			

THIS PAGE INTENTIONALLY LEFT BLANK



FRYMASTER
8700 LINE AVENUE, SHREVEPORT, LA 71106-6800

318-865-1711
844-724-CARE (2273)
WWW.FRYMASTER.COM
EMAIL: SERVICE@FRYMASTER.COM



Every new piece of Manitowoc Foodservice equipment comes with KitchenCare™ and you choose the level of service that meets your operational needs from one restaurant to multiple locations.

StarCare – Warranty & lifetime service, certified OEM parts, global parts inventory, performance audited

ExtraCare – CareCode, 24/7 Support, online/mobile product information

LifeCare – Install & equipment orientation, planned maintenance, KitchenConnect™, MenuConnect

Talk with KitchenCare™ - 1-844-724-CARE - www.mtwkitchencare.com



To learn how Manitowoc Foodservice and its leading brands can equip you, visit our global web site at www.manitowocfoodservice.com, then discover the regional or local resources available to you.

