



# E4 High Production RE (HPRRE) RE80 Electric Service & Parts Manual

- HPRE80, FPRE80, XFPRE80, XRE, FPRE80 and RE80 Models
- YUM YSCFRE18, XYCFRE18 and XYSCFRE18 Models



Frymaster, a member of the Commercial Food Equipment Service Association, recommends using CFESA Certified Technicians.

**24-Hour Service Hotline 1-800-551-8633**

[www.frymaster.com](http://www.frymaster.com)

E-mail: [fryservice@welbilt.com](mailto:fryservice@welbilt.com)



06/2019

8 1 9 6 6 6 6

**NOTICE**

IF, DURING THE WARRANTY PERIOD, THE CUSTOMER USES A PART FOR THIS FRYMASTER FOOD SERVICE EQUIPMENT OTHER THAN AN **UNMODIFIED** NEW OR RECYCLED PART PURCHASED DIRECTLY FROM FRYMASTER DEAN, OR ANY OF ITS AUTHORIZED SERVICE CENTERS, AND/OR THE PART BEING USED IS MODIFIED FROM ITS ORIGINAL CONFIGURATION, THIS WARRANTY WILL BE VOID. FURTHER, FRYMASTER DEAN AND ITS AFFILIATES WILL NOT BE LIABLE FOR ANY CLAIMS, DAMAGES OR EXPENSES INCURRED BY THE CUSTOMER WHICH ARISE DIRECTLY OR INDIRECTLY, IN WHOLE OR IN PART, DUE TO THE INSTALLATION OF ANY MODIFIED PART AND/OR PART RECEIVED FROM AN UNAUTHORIZED SERVICE CENTER.

**⚠ DANGER**

Copper wire suitable for at least 167°F (75°C) must be used for power connections.

**⚠ DANGER**

The electrical power supply for this appliance must be the same as indicated on the rating and serial number plate located on the inside of the fryer door.

**⚠ DANGER**

This appliance must be connected to the voltage and phase as specified on the rating and serial number plate located on the inside of the fryer door.

**⚠ DANGER**

All wiring connections for this appliance must be made in accordance with the wiring diagrams furnished with the equipment. Wiring diagrams are located on the inside of the fryer door.

**⚠ DANGER**

Do not store or use gasoline or other flammable vapors and liquids in the vicinity of this or any other appliance.

**⚠ WARNING**

Do not attach accessories to this fryer unless fryer is secured from tipping. Personal injury may result.

**⚠ WARNING**

Frymaster fryers equipped with legs are for permanent installations. Fryers fitted with legs must be lifted during movement to avoid damage and possible bodily injury. For a moveable or portable installation, Frymaster optional equipment casters must be used. Questions? Call 1-800-551-8633 or email at [fryservice@welbilt.com](mailto:fryservice@welbilt.com).

**⚠ WARNING**

Do not use water jets to clean this equipment.

**⚠ WARNING**

This equipment is intended for indoor use only. Do not install or operate this equipment in outdoor areas.

**⚠ DANGER**

Adequate means must be provided to limit the movement of this appliance without depending on or transmitting stress to the electrical conduit. A restraint kit is provided with the fryer. If the restraint kit is missing contact your local Frymaster Factory Authorized Servicer (FAS) for part number 826-0900.

**⚠ DANGER**

Prior to movement, testing, maintenance and any repair on your Frymaster fryer, disconnect all electrical power from the fryer.

**ELECTRICAL POWER SPECIFICATIONS**

Three (3) Phase Requirements								
kW	VOLTAGE	PHASE	WIRE SERVICE	MINIMUM SIZE		AMPS PER LEG		
				AWG	mm <sup>2</sup>	L1	L2	L3
17	208	3	3	4	16	48	48	48
17	240	3	3	6	16	41	41	41
17	480	3	3	8	16	21	21	21
17	220/380	3	4	8	16	26	26	26
17	240/415	3	4	8	16	24	24	24
17	230/400	3	4	8	16	25	25	25
21	208	3	3	4	25	58	58	58
21	240	3	3	4	25	51	51	51
21	480	3	3	8	16	25	25	25
21	220/380	3	4	6	16	32	32	32
21	240/415	3	4	8	16	29	29	29
21	230/400	3	4	8	16	30	30	30

# E4 SERIES HIGH PRODUCTION RE ELECTRIC FRYERS TABLE OF CONTENTS

---

<b>CAUTIONARY STATEMENTS</b> .....	i
<b>ELECTRICAL POWER SPECIFICATIONS</b> .....	ii
<b>CHAPTER 1: Service Procedures</b>	
1.1 General .....	1-1
1.2 Replacing a Controller.....	1-1
1.3 Replacing Component Box Components .....	1-1
1.4 Replacing a High-Limit Thermostat.....	1-3
1.5 Replacing a Temperature Probe .....	1-3
1.6 Replacing a Heating Element .....	1-5
1.7 Replacing Contactor Box Components .....	1-6
1.8 Replacing a Frypot .....	1-7
1.9 Built-In Filtration System Service Procedures.....	1-9
1.9.1 Filtration System Problem Resolution .....	1-9
1.9.2 Replacing the Filter Motor, Filter Pump and Related Components .....	1-10
1.9.3 Replacing the Filter Transformer or Filter Relay .....	1-12
1.10 Basket Lift Service Procedures .....	1-12
1.11 Interface Board Diagnostic Chart.....	1-15
1.12 Probe Resistance Chart.....	1-16
1.13 Wiring Diagrams .....	1-17
1.13.1 Basket Lift (480V/120V Control Supply).....	1-17
1.13.2 PBI Basket Lift.....	1-18
1.13.3 Standard Component Wiring.....	1-18
1.13.4 KFC1 and CM4s Component Wiring.....	1-19
1.13.5 Component Wiring – Single Phase .....	1-20
1.13.6 Component Wiring – 480V Non-Filter .....	1-21
1.13.7 Component Wiring – Fast Ready .....	1-22
1.13.8 Component Wiring – KFC India K3000 .....	1-23
1.13.9 Component Wiring – KFC India Fast .....	1-24
1.13.10 Contactor Box – Domestic 17 kW .....	1-25
1.13.11 Contactor Box – Domestic 21 kW .....	1-25
1.13.12 Contactor Box – Export 17kW and 21kW .....	1-26
1.13.13 Contactor Box – Chinese Export 17kW and 21kW .....	1-27
1.13.14 Contactor Box – Export KFC India 17kW .....	1-27
<b>CHAPTER 2: Parts List</b>	
2.1 Accessories .....	2-1
2.2 Cabinetry .....	2-2
2.2.1 Backs, Control Panel Frames, Doors, Sides, Tilt Housings and Top Caps.....	2-2
2.2.2 Cabinet Bases, Braces and Associated Parts .....	2-5
2.2.3 Basket Lift Assembly and Associated Parts.....	2-7
2.3 Filtration System Components .....	2-9
2.3.1 Filter Pan .....	2-9
2.3.1 Filter Pump.....	2-11
2.4 Drain System Components.....	2-12
2.4.1 Drain Valves and Associated Parts .....	2-12
2.4.2 Drain System Plumbing.....	2-14

**E4 SERIES HIGH PRODUCTION RE ELECTRIC FRYERS**  
**TABLE OF CONTENTS (cont.)**

---

2.5	Oil Return System Components .....	2-15
2.5.1	Oil Disposal Wand .....	2-15
2.5.2	KFC Over-the-Top Return .....	2-18
2.5.3	Drain Flush .....	2-19
2.6	Heating Elements .....	2-20
2.6.1	Element Assemblies and Hardware .....	2-20
2.6.2	Element Tube Assembly .....	2-22
2.7	Frypots and Associated Parts .....	2-23
2.8	Controllers .....	2-24
2.9	Electronics and Electrical Components .....	2-25
2.9.1	Component Boxes .....	2-25
2.9.2	Contactors Boxes .....	2-27
2.9.3	Fuse Boxes .....	2-29
2.9.4	Terminal Blocks .....	2-30
2.9.5	Cord Sets .....	2-31
2.10	Wiring .....	2-31
2.10.1	Contactors Box Wiring Assemblies 6-Pin (Left) & 9-Pin (Right) Elements .....	2-31
2.10.2	Component Box, Filter Pump and Basket Lift Wiring Harnesses .....	2-32
2.11	Wiring Connectors and Pin Connectors .....	2-33
2.12	Fasteners .....	2-34

# E4 SERIES HIGH PRODUCTION RE ELECTRIC FRYERS

## CHAPTER 1: SERVICE PROCEDURES

---

### 1.1 General

Before performing any maintenance on your Frymaster fryer, disconnect the fryer from the electrical power supply.

When electrical wires are disconnected, it is recommended that they be marked in such a way as to facilitate re-assembly.

### 1.2 Replacing a Controller

1. Disconnect the fryer from the electrical power supply.
2. The controller bezel is held in place by tabs at the top and bottom. Slide the metal bezel up to disengage the lower tabs. Then slide the bezel down to disengage the upper tabs.
3. Remove the two screws from the upper corners of the control panel. The control panel is hinged at the bottom and swings open from the top.
4. Unplug the wiring harness from the connector on the back of the controller and disconnect the grounding wire from terminal adjacent to the connector. Remove the control panel assembly by lifting it from the hinged slots in the control panel frame.
5. Remove the controller from the control panel assembly and install the replacement controller. Reinstall the control panel assembly by reversing steps 1 and 2.

### 1.3 Replacing Component Box Components

1. Disconnect the fryer from the electrical power supply.
2. The controller bezel is held in place by tabs at the top and bottom. Slide the metal bezel up to disengage the lower tabs. Then slide the bezel down to disengage the upper tabs.
3. Remove the two screws from the upper corners of the control panel and allow the control panel to swing down.
4. Unplug the wiring harness from the 15-pin connector on the interface board and disconnect the grounding wire from terminal adjacent to the 15-pin connector on the back of the controller. Remove the control panel assembly by lifting it from the hinge slots in the control panel frame.
5. Disconnect the wiring from the component to be replaced, being sure to make a note of where each wire was connected.
6. Dismount the component to be replaced and install the new component, being sure that any required spacers, insulation, washers, etc. are in place.

**NOTE:** If more room to work is required, the control panel frame assembly may be removed by removing the hex head screws that secure it to the fryer cabinet (see illustration below). If this option is chosen, all control panel assemblies must be removed per steps 1 and 2 above. The cover plate on the lower front of the component box may also be removed if desired. *Removing the component box itself from the fryer is not recommended due to the difficulty involved in disconnecting and reconnecting the oil-return valve rods, which pass through openings in the component box.*

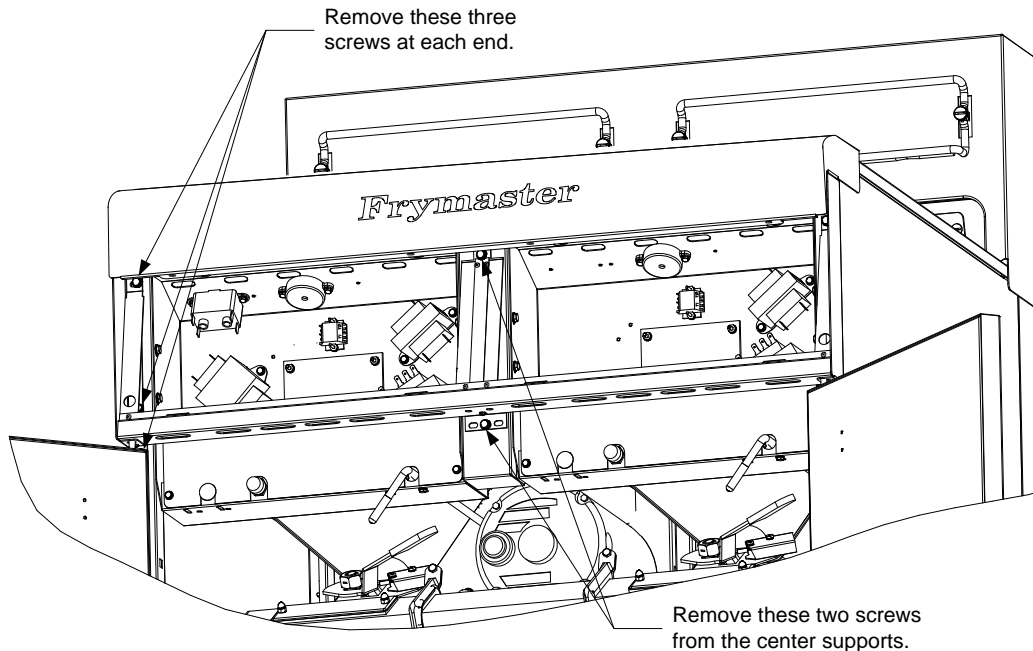

**Removing the Control Panel Frame and Top Cap Assembly**

7. Reconnect the wiring disconnected in Step 3, referring to your notes and the wiring diagrams on the fryer door to ensure that the connections are properly made. Also, verify that no other wiring was disconnected accidentally during the replacement process.
8. Reverse steps 1 through 4 to complete the replacement and return the fryer to service.

#### **1.4 Replacing a High-Limit Thermostat**

1. Remove the filter pan and lid from the unit. Drain the frypots into a Shortening Disposal Unit (SDU) or other appropriate metal container.



**DO NOT drain more than one full frypot or two split frypots into the SDU at one time.**

2. Disconnect the fryer from the electrical power supply and reposition it to gain access to the rear of the fryer.
3. Remove the four screws from both the left and right sides of the lower back panel.

4. Locate the high-limit that is being replaced and follow the two-black wires to the 12-pin connector C-6. Note where the leads are connected prior to removing them from the connector. Unplug the 12-pin connector C-6 and using a pin-pusher push the pins of the high-limit out of the connector.
5. Using a wrench, carefully unscrew the high-limit thermostat to be replaced.
6. Apply Loctite™ PST 567 or equivalent sealant to the threads of the replacement and screw it securely into the frypot.
7. Insert the leads into the 12-pin connector C-6 (see illustration below). For full-vat units or the left half of a dual-vat unit (as viewed from the rear of the fryer) the leads go into positions 1 and 2 of the connector. For the right half of a dual-vat unit (as viewed from the rear of the fryer), the leads go into positions 7 and 8. In either case, polarity does not matter.

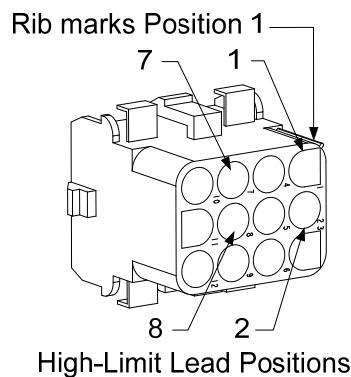

8. Reconnect the 12-pin connecting plug C-6. Use wire ties to secure any loose wires.
9. Reinstall the back panels reposition the fryer under the exhaust hood, and reconnect it to the electrical power supply to return the fryer to service.

## 1.5 Replacing a Temperature Probe

1. Remove the filter pan and lid from the unit. Drain the frypots into a Shortening Disposal Unit (SDU) or other appropriate metal container.

**⚠ DANGER**  
**DO NOT drain more than one full frypot or two split frypots into the SDU at one time.**

2. Disconnect the fryer from the electrical power supply and reposition it to gain access to the rear of the fryer.
3. Remove the four screws from both sides of the lower back panel. Then remove the two screws on both the left and right sides of the back of the tilt housing. Lift the tilt housing straight up to remove from the fryer.
4. Locate the red and white wires of the temperature probe to be replaced. Note where the leads are connected prior to removing them from the connector. Unplug the 12-pin connector C-6 and using a pin-pusher push the pins of the temperature probe out of the connector.



5. Raise the element and remove the securing probe bracket and metal tie wraps that secure the probe to the element (see illustration below).

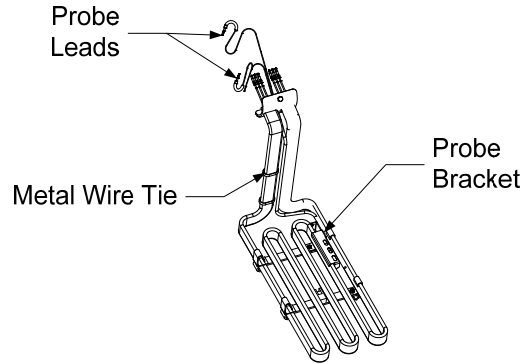

6. Gently pull on the temperature probe and grommet, pulling the wires up the rear of the fryer and through the element tube assembly.
7. Insert the replacement temperature probe (wires first) into the tube assembly ensuring that the grommet is in place. Secure the probe to the elements using the bracket which was removed in Step 5 and the metal tie wraps which were included in the replacement kit.
8. Route the probe wires out of the tube assembly following the element wires down the back of the fryer through the Heyco bushings to the 12-pin connector C-6. Secure the wires to the sheathing with wire ties.
9. Insert the temperature probe leads into the 12-pin connector C-6 (see illustration below). For full-vat units or the right half of a dual-vat unit (as viewed from the rear of the fryer) the red lead goes into position 3 and the white lead into position 4 of the connector. For the left half of a dual-vat unit (as viewed from the rear of the fryer), the red lead goes into position 9 and the white lead into position 10. **NOTE: Right and left** refer to the fryer as viewed from the rear.

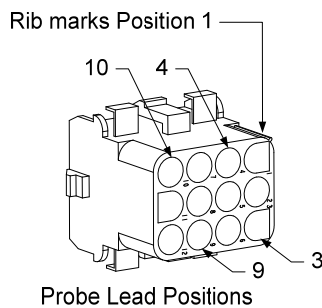

10. Secure any loose wires with wire ties making sure that the lead wires will not interfere with the movement of the springs. Rotate the elements up and down making sure that movement is not restricted and that the wires are not pinched.
11. Reinstall the tilt housing and back panels, reposition the fryer under the exhaust hood, and reconnect it to the electrical power supply to return the fryer to service.

## 1.6 Replacing a Heating Element

1. Perform steps 1-3 of section 1.5, *Replacing a Temperature Probe*.

2. On dual-vat fryers, and on full-vat fryers where the temperature probe is attached to the element being replaced, disconnect the wire harness containing the probe wiring. Using a pin pusher, disconnect the probe wires from the 12-pin connector C-6.
3. Remove screws holding element wiring cover in place and remove cover.
4. In the rear of the fryer directly behind the frypot disconnect the 6-pin connector for the left element (as viewed from the front of the fryer) or the 9-pin connector for the right element. Press in on the tabs on each side of the connector while pulling outward on the free end to extend the connector and release the element leads (see photo below). Pull the leads out of the connector and out of the wire sleeving.

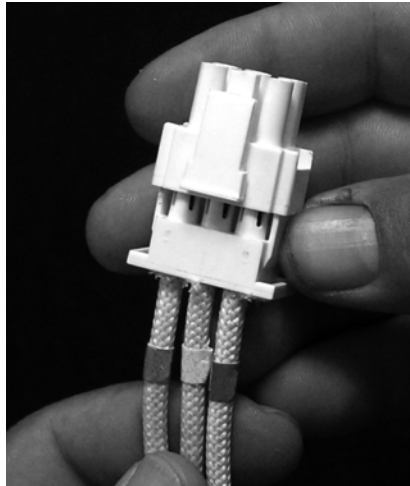

5. Raise the element to the full up position and support the elements.
6. Remove the hex head screws and nuts that secure the element to the tube assembly and pull the element out of the frypot. **NOTE:** Full-vat elements consist of two dual-vat elements clamped together. For full-vat units, remove the element clamps before removing the nuts and screws that secure the element to the tube assembly.
7. If applicable, recover the probe bracket and probe from the element being replaced and install them on the replacement element. Install the replacement element in the frypot, securing it with the nuts and screws removed in Step 5 to the tube assembly. Ensure the gasket is between the tube and element assembly.
8. Route the element leads through the element tube assembly and into the wire sleeving to prevent chafing. Ensure that the wire sleeving is routed back through the Heyco bushing keeping it clear from the lift springs. Also ensure that the wire sleeving extends into the tube assembly to prevent the edge of the tube assembly from chafing the wires. Press the pins into the connector in accordance with the diagram on the following page, and then close the connector to lock the leads in place. **NOTE:** It is critical that the wires be routed through the sleeving to prevent chafing.

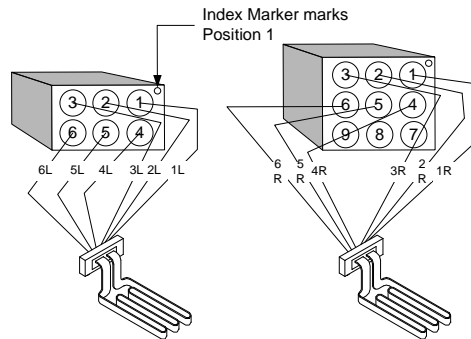

9. Reconnect the element connector ensuring that the latches lock.
10. Insert the temperature probe leads into the 12-pin wiring harness connector C-6 (see illustration below). For full-vat units or the right half of a dual-vat unit, the red lead goes into position 3 and the white into position 4. For the left half of a dual-vat unit, the red lead goes into position 9 and the white into position 10. **NOTE: Right and left** refer to the fryer as viewed from the rear.

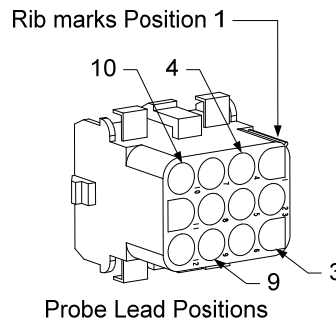

10. Reconnect the 12-pin connector C-6 of the wiring harness disconnected in Step 2.
11. Lower the element down onto the basket rack.
12. Reinstall the tilt housing, upper cover and back panels, reposition the fryer under the exhaust hood, and reconnect it to the electrical power supply.

## 1.7 Replacing Contactor Box Components

1. If replacing a contactor box component above the built-in filter system, remove the filter pan and lid from the unit. Drain the frypots into a Shortening Disposal Unit (SDU) or other appropriate metal container. If replacing a contactor box component in a non-filter unit or a frypot that's not over the filter pan, drain the frypot above the box into a Shortening Disposal Unit (SDU) or other appropriate metal container.



**DANGER**

**DO NOT drain more than one full frypot or two split frypots into the SDU at one time.**

2. Disconnect the fryer from the electrical power supply.
3. Remove the two screws securing the cover of the contactor box. The contactor boxes above the filter pan are accessed by sliding under the fryer. They are located to the left and right above the

guide rails (see photo below). The contactor boxes of non-filter units or frypots not over the filter pan are accessed by opening the fryer door directly under the affected frypot.

4. The contactors and relays are held on by threaded pin studs so that only removal of the nut is required to replace the component.
5. After performing necessary service, reverse steps 1-4 to return the fryer to operation.

## 1.8 Replacing a Frypot

1. Drain the frypot into the filter pan or, if replacing a frypot over the filter system, into a Shortening Disposal Unit (SDU) or other appropriate metal container. If replacing a frypot over the filter system, remove the filter pan and lid from the unit.

### DANGER

**DO NOT drain more than one full frypot or two split frypots into the SDU at one time.**

2. Disconnect the fryer from the electrical power supply and reposition it to gain access to both the front and rear.
3. Slide the metal bezel up to release the bottom tabs, then slide the bezel down to disengage the upper tabs.
4. Remove the two screws from the upper corners of the control panels and allow them to swing down (see illustration and photo on page 1-1).
5. Unplug the wiring harnesses and ground wires from the backs of the controllers. Remove the controllers by lifting them from the hinge slots in the control panel frame.
6. Remove the tilt housing and back panels from the fryer. The tilt housing must be removed first in order to remove the upper back panel.
7. To remove the tilt housing remove the hex head screws from the rear edge of the housing. The housing can be lifted straight up and off the fryer.
8. Remove the control panel by removing the screw in the center and the nuts on both sides.
9. Loosen the component boxes by removing the screws, which secure them in the cabinet.
10. Dismount the top cap by removing the nuts at each end that secure it to the cabinetry.
11. Remove the hex head screw that secures the front of the frypot to the cabinet cross brace.
12. Remove the top-connecting strip that covers the joint with the adjacent frypot.
13. Unscrew the Teflon vent/vacuum-breaker tube fitting, unscrew the nut located on the front of each section of drain tube, and remove the tube assembly from the fryer.

14. Remove the covers from the drain safety switch(es) and disconnect the switch wiring at the switch(es).
15. At the rear of the fryer, unplug the 12-pin connector C-6 and, using a pin pusher, disconnect the high-limit thermostat leads.
16. Disconnect the oil return flexline(s) at the frypot end(s).
17. Raise the elements to the “up” position and disconnect the element springs.
18. Remove the machine screws and nuts that secure the element tube assembly to the frypot. Carefully lift the element assembly from the frypot and secure it to the cross brace on the rear of the fryer with wire ties or tape.
19. Carefully lift the frypot from the fryer and place it upside down on a stable work surface.
20. Recover the drain valve(s), oil return flexline connection fitting(s), and high-limit thermostat(s) from the frypot. Clean threads and apply Loctite™ PST 567 or equivalent sealant to the threads of the recovered parts and install them in the replacement frypot.
21. Carefully lower the replacement frypot into the fryer. Reinstall the hex head screw removed in step 7 to attach the frypot to the fryer.
22. Position the element tube assembly in the frypot and reinstall the machine screws and nuts removed in step 14.
23. Reconnect the oil return flexlines to the frypot, and replace aluminum tape, if necessary, to secure heater strips to the flexlines.
24. Insert the high-limit thermostat leads disconnected in step 13 (see illustration on page 1-3 for pin positions).
25. Reconnect the drain safety switch wiring to the switch(es) in accordance with the diagram below then reinstall the switch covers.

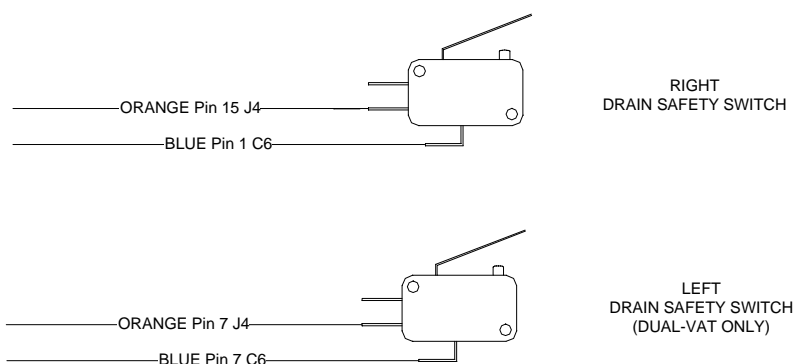

26. Reinstall the drain tube assembly.
27. Reinstall the top connecting strips, top cap, control panel, component box, tilt housing and back panels.
28. Reinstall controllers in the control panel frame and reconnect the wiring harnesses and ground wires.
29. Reposition the fryer under the exhaust hood and reconnect it to the electrical power supply.

## 1.9 Built-in Filtration System Service Procedures

### 1.9.1 Filtration System Problem Resolution

One of the most common causes of filtration problems is placing the filter paper on the bottom of the filter pan rather than over the filter screen.

**⚠ CAUTION**  
**Ensure that filter screen is in place prior to filter paper placement and filter pump operation. Improper screen placement is the primary cause of filtration system malfunction.**

Whenever the complaint is “the pump is running, but no oil is being filtered,” check the installation of the filter paper, and ensure that the correct size is being used. While you are checking the filter paper, verify that the O-rings on the pick-up tube of the filter pan are in good condition. Missing or worn O-rings allow the pump to take in air and decrease its efficiency.

If the pump motor overheats, the thermal overload will trip and the motor will not start until it is reset. If the pump motor does not start, press the red reset switch (button) located on the rear of the motor at the front of the fryer.

If the pump starts after resetting the thermal overload switch, then something is causing the motor to overheat. A major cause of overheating is when several frypots are filtered sequentially, overheating the pump and motor. Allow the pump motor to cool at least 30 minutes before resuming operation. Pump overheating can be caused by:

- Solidified shortening in the pan or filter lines, or
- Attempting to filter unheated oil (cold oil is more viscous, overloading the pump motor and causing it to overheat).

If the motor runs but the pump does not return oil, there is a blockage in the pump. Incorrectly sized or installed paper/pads will allow food particles and sediment to pass through the filter pan and into the pump. When sediment enters the pump, the gears bind, causing the motor to overload, again tripping the thermal overload. Shortening that has solidified in the pump will also cause it to seize, with the same result.

A pump seized by debris or hard shortening can usually be freed by manually moving the gears with a screwdriver or other instrument.

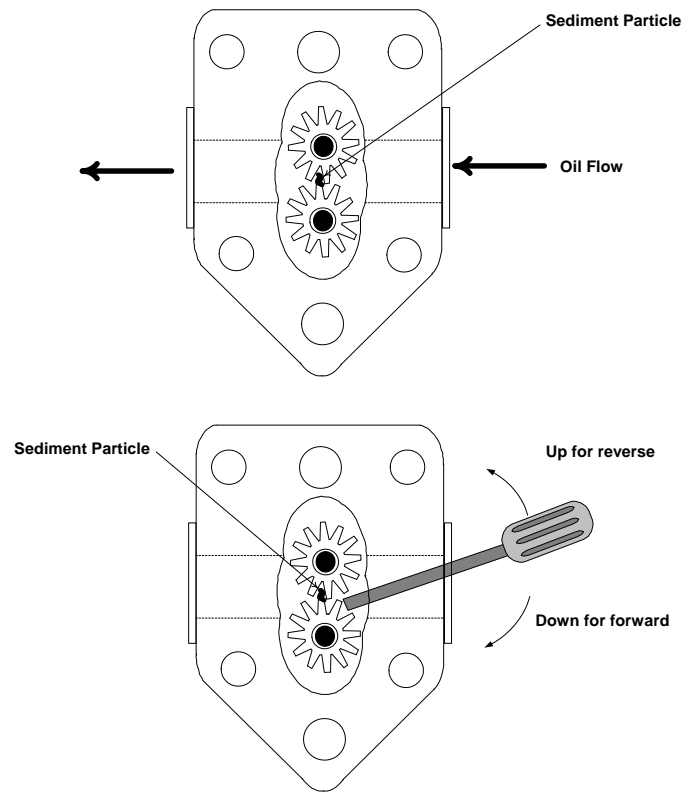

Disconnect power to the filter system, remove the input plumbing from the pump, and use a screwdriver to manually turn the gears.

- Turning the pump gears in reverse will release a hard particle.
- Turning the pump gears forward will push softer objects and solid shortening through the pump and allow free movement of the gears.

Incorrectly sized or installed paper/pads will also allow food particles and sediment to pass through and clog the suction tube on the bottom of the filter pan. Particles large enough to block the suction tube may indicate that the crumb tray is not being used. Pan blockage can also occur if shortening is left in the pan and allowed to solidify. Blockage removal can be accomplished by forcing the item out with an auger or drain snake. Compressed air or other pressurized gases should not be used to force out the blockage.

### 1.9.2 Replacing the Filter Motor, Filter Pump, and Related Components

1. Drain the frypots into a Shortening Disposal Unit (SDU) or other appropriate metal container.

**⚠ DANGER**

**DO NOT drain more than one full frypot or two split frypots into the SDU at one time.**

2. Disconnect the fryer from the electrical power supply and reposition it to gain access to both the front and rear.
3. Disconnect the two flexlines running to the oil-return manifold at the rear of the fryer as well as the pump suction flexline at the end of the filter pan connection (see photo below).

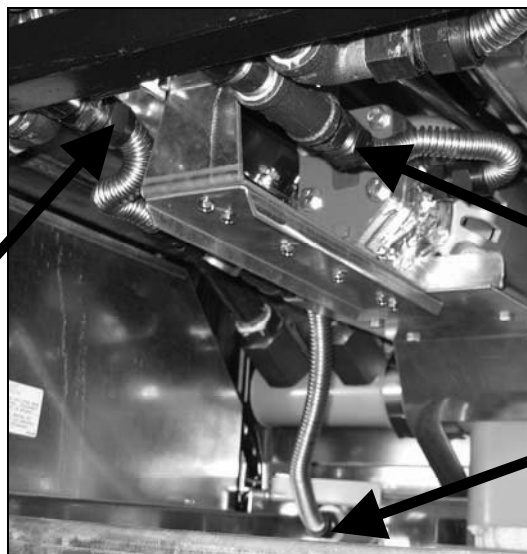

Disconnect flexlines indicated by the arrows.

4. Remove the cover plate from the front of the motor and disconnect the motor wires.
5. Unplug the pump motor assembly 6-pin connector C-2 and, using a pin pusher, disconnect the vent vacuum-breaker solenoid (pins 2 and 5) that is attached to the oil return manifold.

6. When complete, reverse steps to reinstall the bridge. **NOTE:** The black motor wires go on the top terminal, the white on the bottom. The pump solenoid valve wires go in positions 1 and 4 of the 6-pin connector C-2; the vent vacuum-breaker solenoid valve wires go in positions 2 and 5; the red/black heater tape wires go into position 3 and the violet/white wires go into position 6 (see illustration on the following page).
7. Disconnect any heater tape wiring from connectors and remove heater tape. Motor and pump can be separated and removed individually or as one unit.

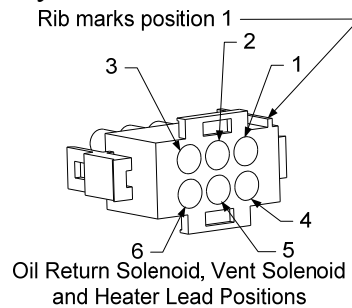

8. Reconnect the unit to the electrical power supply, and verify that the pump is functioning correctly (i.e., when a filter handle is placed in the ON position, the motor should start and there should be strong suction at the intake fitting and outflow at the rear flush port.)
9. When proper operation has been verified, reinstall the back panels and the filter pan and lid.
10. Reposition the fryer under the exhaust hood and reconnect it to the electrical power supply to return the fryer to service.

### 1.9.3 Replacing the Filter Transformer or Filter Relay

Disconnect the fryer from the electrical power supply. Remove the left controller from the fryer to expose the interior of the left component box. The filter transformer and relay are behind the controller on a single fryer or just right of the filter in a bank of two or more. The filter transformer and relay are located as shown in the illustration below.

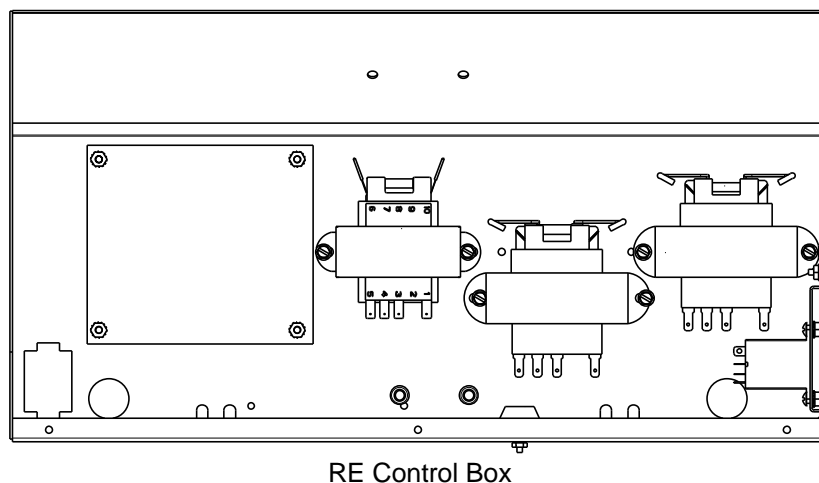



## 1.10 Basket Lift Service Procedures

High Production RE Series electric fryers may be equipped with automatic basket lifts. Basket lifts always come in pairs, although each operates independently.

A **modular basket lift** (illustrated on the following page) is a self-contained sub-assembly consisting of a pair of toothed rods which support removable basket lift arms, a pair of reversible-drive gear motors, and four microswitches. The gear motors engage the teeth of the rods, moving them up or down depending upon the motors' direction of rotation. The microswitches at the upper and lower limits of movement stop the motors when the basket is in the full up or full down position. Timing circuitry in the controller initiates and stops basket lift operation depending upon the variables programmed by the operator. When the product button is pressed, the timing circuitry activates a coil in the basket lift relay to supply power to the lower microswitch. The microswitches stop the motor at the lift's upper and lower travel limits and reverse the direction of current flow thus reversing the motor direction.

When the product button is pushed on the computer/controller, current flows through a coil in the basket lift relay, causing the lower circuit to be activated. The basket lift lowers, closing the normally open upper-micro-switch. When the downward-moving rod opens the lower normally closed microswitch, the power to the motor ceases to flow. When the computer/controller times out, the current to the relay coil is cut, allowing the upper circuit to be activated. The basket lift then raises and re-closes the lower microswitch. When the basket lift rod clears the upper microswitch, the microswitch reopens, power to the circuit is cut, and the motor stops. Pushing the product button restarts the cycle.

Problems with the basket lift can be grouped into three categories:

- Binding/jamming problems
- Motor and gear problems
- Electronic problems

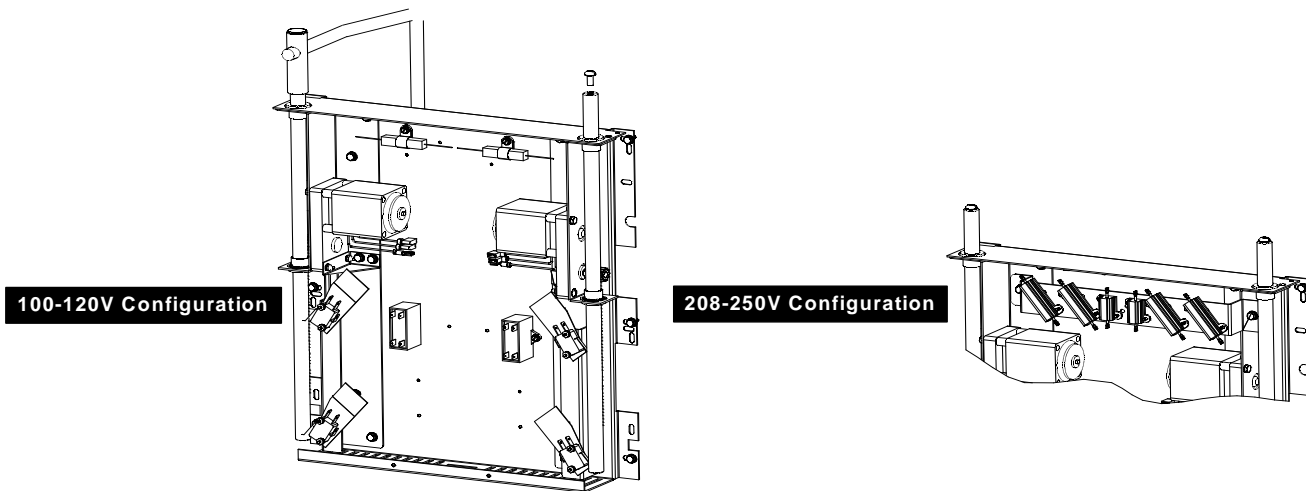

## BINDING/JAMMING PROBLEMS

Noisy, jerky or erratic movement of the lifts is usually due to lack of lubrication of the rods and their bushings. Apply a light coat of Lubriplate<sup>®</sup> or similar lightweight white grease to the rod and bushings to correct the problem.

With the modular basket lift, another possible cause of binding is improper positioning of the motor, which prevents the gear from correctly engaging the teeth in the rod. To correct the problem, loosen the screws that hold the motor in place and move it forward or backward until the rod has just enough slack to be rotated slightly.

## MOTOR AND GEAR PROBLEMS

With the modular basket lift, the most likely problem to be encountered in this category is erratic motion of the lift due to a worn drive gear. Failure to keep the lift rod and bushings properly lubricated will cause unnecessary wear of the gear. The problem is corrected by replacing the worn gear.

If the lift cycles correctly but fails to remain in the up position (i.e., goes up, but then slowly settles back down into the frypot), the problem is a failed motor brake. A failed motor brake cannot be repaired and requires replacement of the motor itself.

If power is reaching the motor but the motor fails to run, the motor is burned out and must be replaced.

## ELECTRONIC PROBLEMS

Within this category are problems associated with the relays, microswitches, capacitors, resistors, interface board, wiring, and controls. The most common problem in this category is a lift that continuously travels up and down. This is usually caused by a microswitch that is out of adjustment. Troubleshooting the electronics of a modular basket lift is simply a process of verifying current flow through the individual components up to and including the motor. Using a multimeter set to the 250 VAC range, check the connections on both sides of the component for the presence of the applied line voltage. The schematic below and the wiring diagram on page 1-16 can identify the components and wiring connection points.

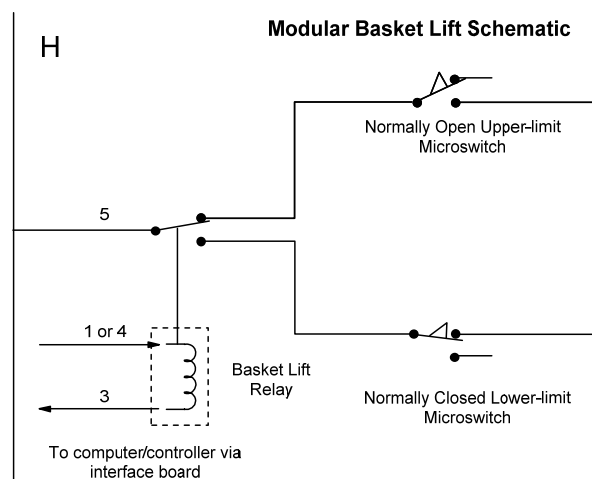

## 1.11 Interface Board Diagnostic Chart

The following diagram and charts provide ten quick system checks that can be performed using only a multimeter.

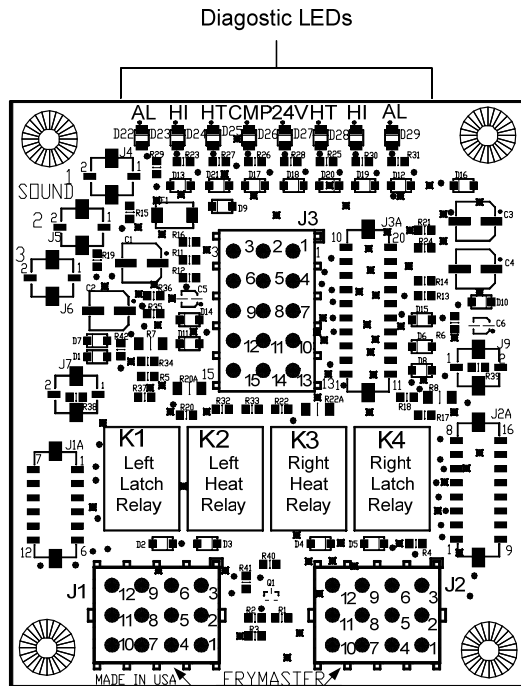

PN 106-6664

Test Points  
J1 Left J2 Right

<b>Diagnostic LED Legend</b>	
<b>CMP</b>	indicates power from 12V transformer
<b>24</b>	indicates power from 24V transformer
<b>HI (RH)</b>	indicates output (closed) from right latch relay
<b>HI (LH)</b>	indicates output (closed) from left latch relay
<b>HT (RH)</b>	indicates output from right heat relay
<b>HT (LH)</b>	indicates output from left heat relay
<b>AL (RH)</b>	indicates output (open) from right latch relay
<b>AL (LH)</b>	indicates output (open) from left latch relay

**NOTE** – When testing the test points on J1 and J2 test use the illustration above disregarding any silk-screened numbers on the board depicting the location of Pin 1. Pin 1 is located in the bottom right corner of both J1 and J2. These test points are **ONLY** for RE Series boards with J1 and J2 plugs on the front of the board.

Meter Setting	Test	Pin	Pin	Results
12 VAC Power	50 VAC Scale	3 of J2	1 of J2	12-16 VAC
24 VAC Power	50 VAC Scale	2 of J2	Chassis	24-30 VAC
*Probe Resistance (RH)	R X 1000 OHMS	11 of J2	10 of J2	See Chart
*Probe Resistance (LH)	R X 1000 OHMS	1 of J1	2 of J1	See Chart
High-Limit Continuity (RH)	R X 1 OHMS	9 of J2	6 of J2	0 - OHMS
High-Limit Continuity (LH)	R X 1 OHMS	6 of J1	9 of J1	0 - OHMS
Latch Contactor Coil (RH)	R X 1 OHMS	8 of J2	Chassis	3-10 OHMS
Latch Contactor Coil (LH)	R X 1 OHMS	5 of J1	Chassis	3-10 OHMS
Heat Contactor Coil (RH)	R X 1 OHMS	7 of J2	Chassis	11-15 OHMS
Heat Contactor Coil (LH)	R X 1 OHMS	4 of J1	Chassis	11-15 OHMS

\* **Disconnect 15-Pin harness from the computer/controller before testing the probe circuit.**

## 1.12 Probe Resistance Chart

<h3 style="text-align: center;">Probe Resistance Chart</h3> <p style="text-align: center;"><i>For use with fryers manufactured with Minco Thermistor probes only.</i></p>																	
F	OHMS	C	F	OHMS	C	F	OHMS	C	F	OHMS	C	F	OHMS	C			
60	1059	16	130	1204	54	200	1350	93	270	1493	132	340	1634	171			
65	1070	18	135	1216	57	205	1361	96	275	1503	135	345	1644	174			
70	1080	21	140	1226	60	210	1371	99	280	1514	138	350	1654	177			
75	1091	24	145	1237	63	215	1381	102	285	1524	141	355	1664	179			
80	1101	27	150	1247	66	220	1391	104	290	1534	143	360	1674	182			
85	1112	29	155	1258	68	225	1402	107	295	1544	146	365	1684	185			
90	1122	32	160	1268	71	230	1412	110	300	1554	149	370	1694	188			
95	1133	35	165	1278	74	235	1422	113	305	1564	152	375	1704	191			
100	1143	38	170	1289	77	240	1432	116	310	1574	154	380	1714	193			
105	1154	41	175	1299	79	245	1442	118	315	1584	157	385	1724	196			
110	1164	43	180	1309	82	250	1453	121	320	1594	160	390	1734	199			
115	1174	46	185	1320	85	255	1463	124	325	1604	163	395	1744	202			
120	1185	49	190	1330	88	260	1473	127	330	1614	166	400	1754	204			
125	1195	52	195	1340	91	265	1483	129	335	1624	168	405	1764	207			

# 1.13 Wiring Diagrams

## 1.13.1 Basket Lift

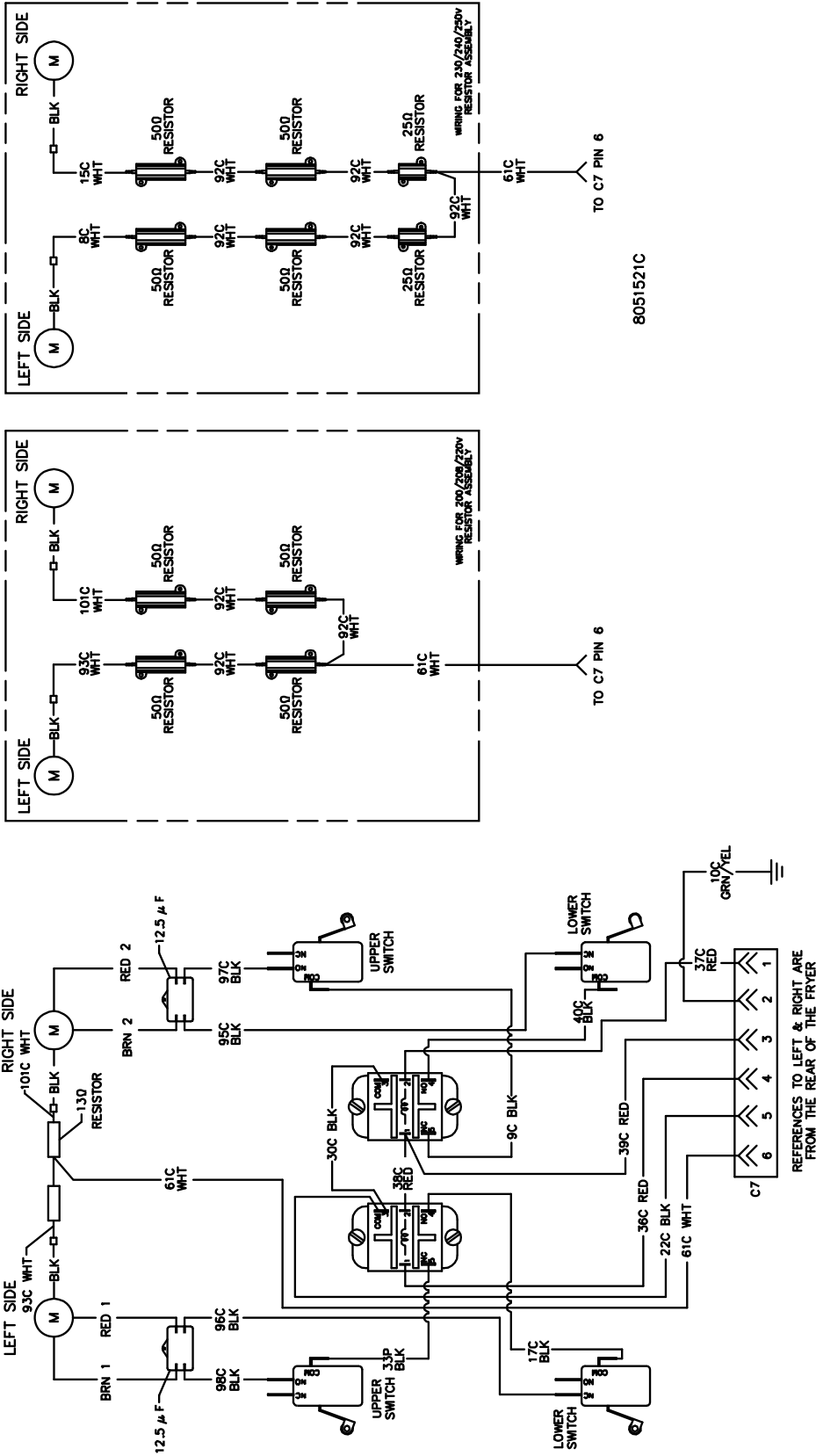

8051521C

### 1.13.2 PBI Basket Lift

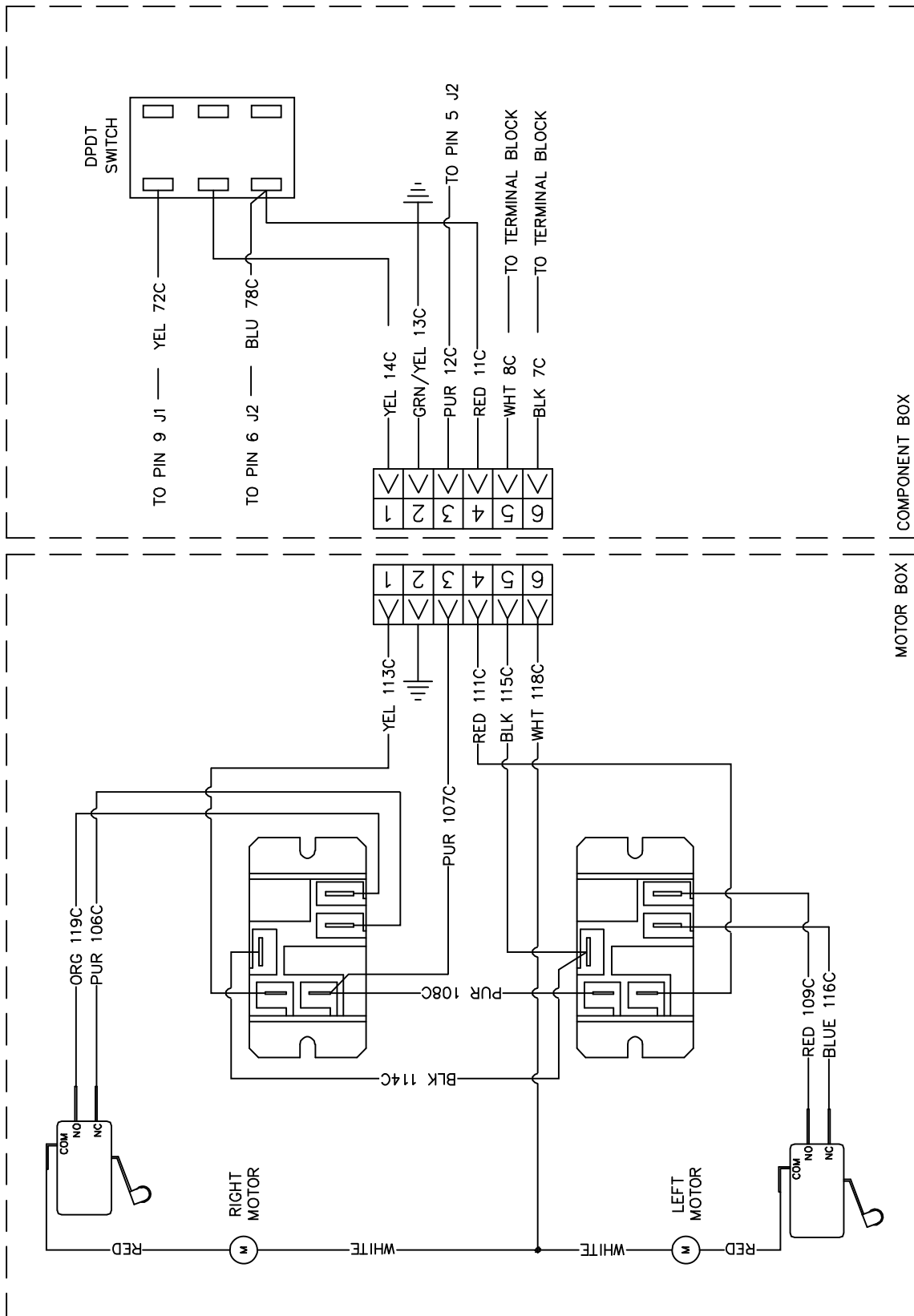

8051789A

COMPONENT BOX

MOTOR BOX

# 1.13.3 Standard Component Wiring

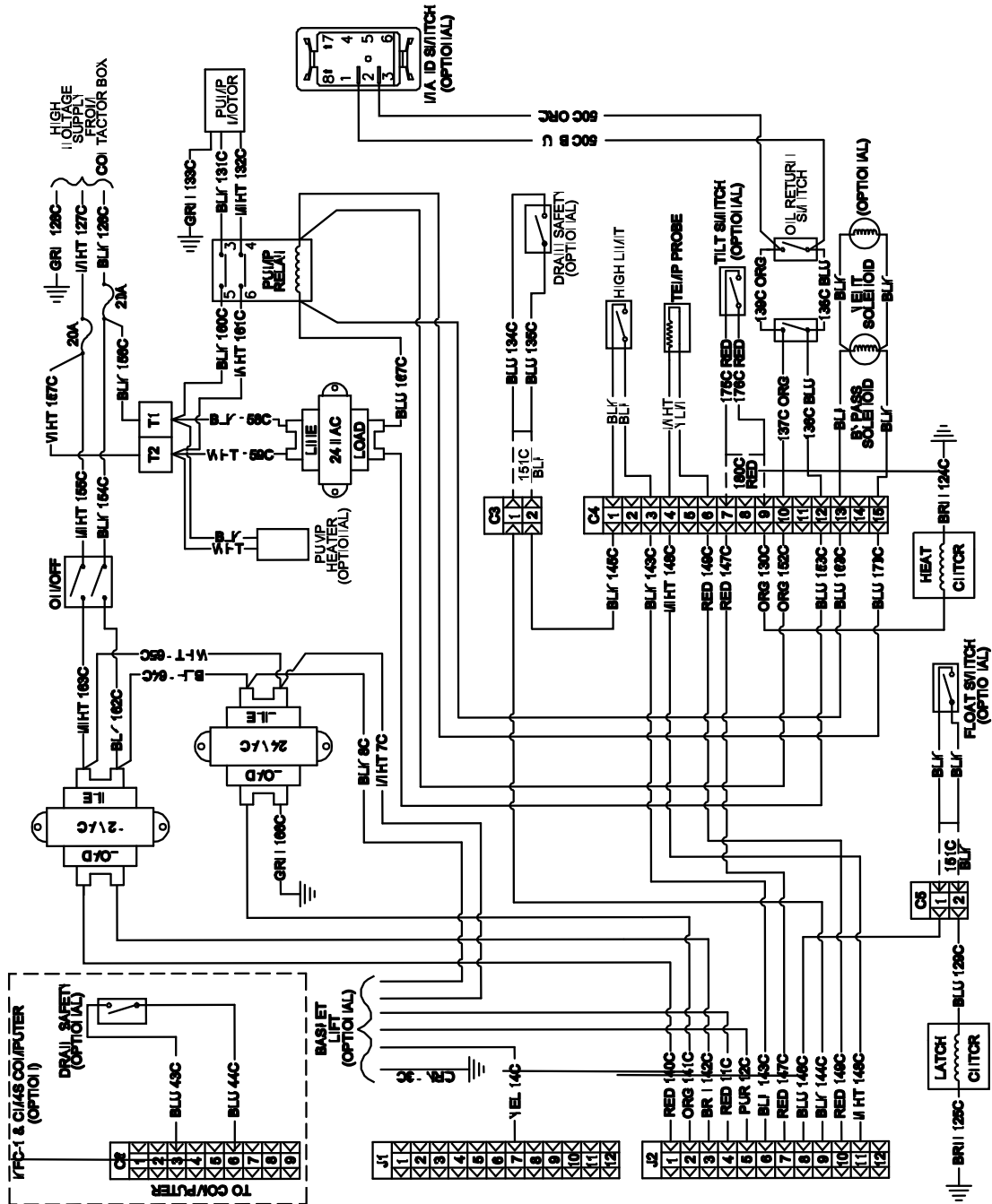

8051762D

### 1.13.4 KFC1 and CM4S Component Wiring

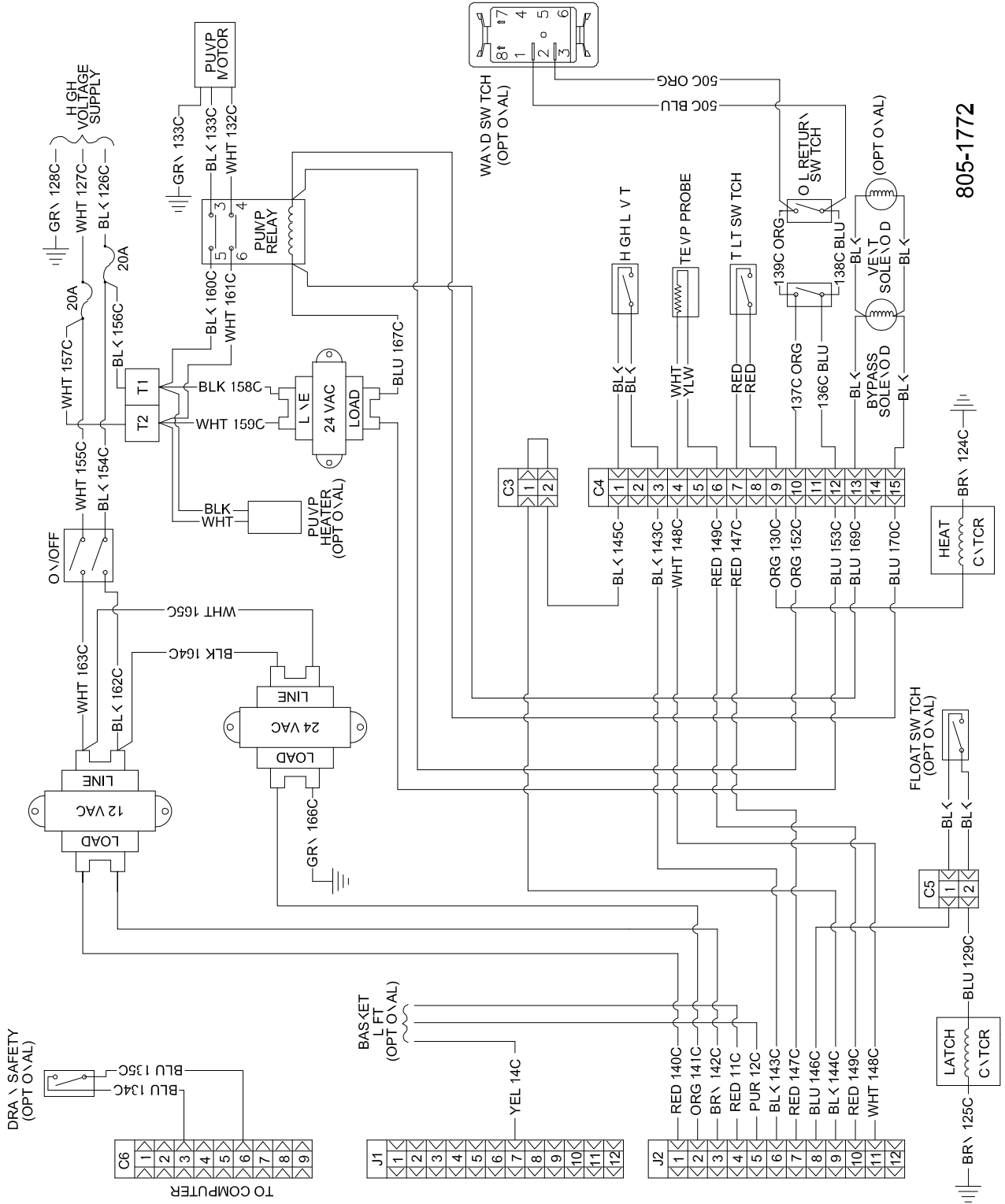

805-1772



# 1.13.5 Component Wiring – Single Phase

805-1786

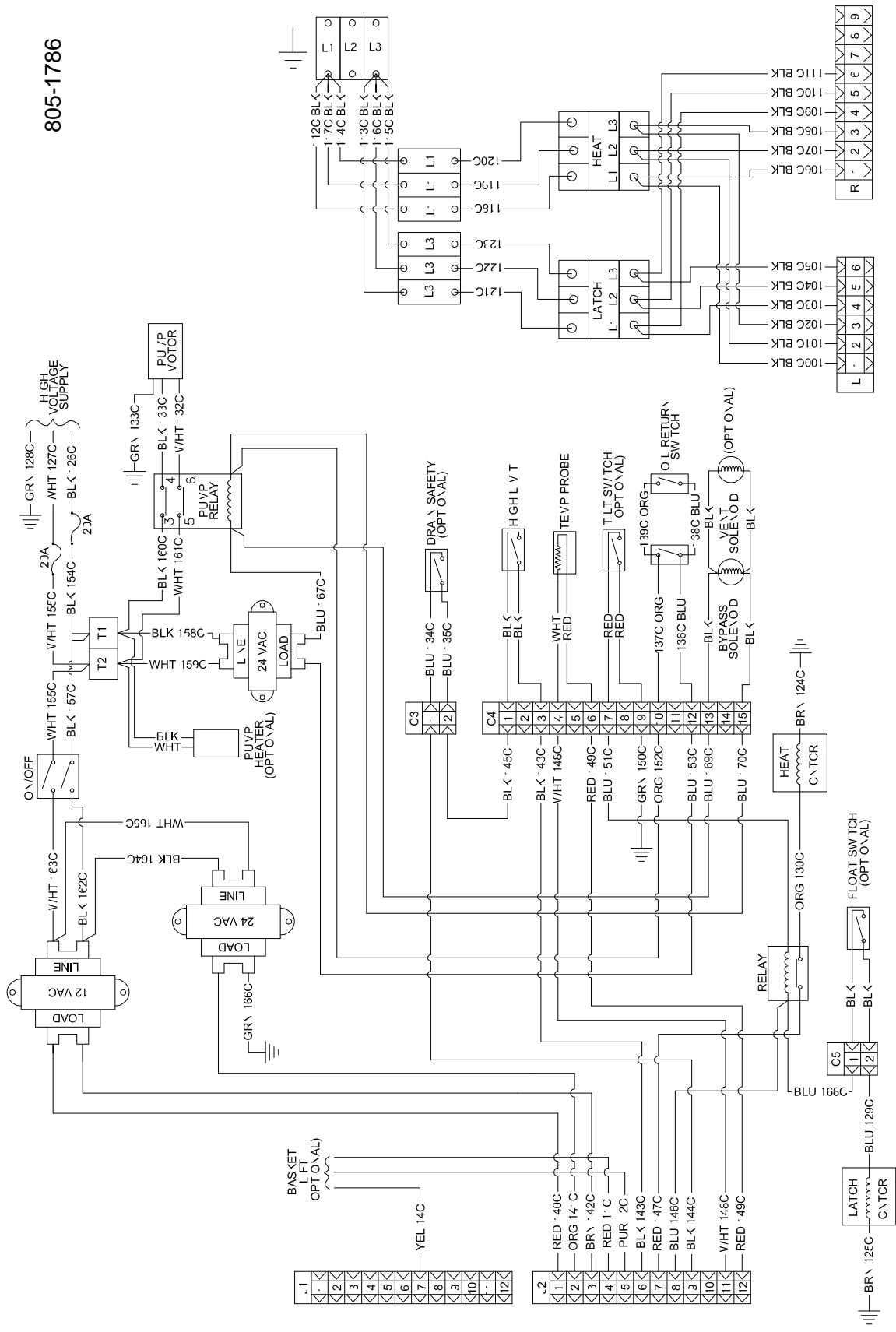

### 1.13.6 Component Wiring – 480V Non-Filter

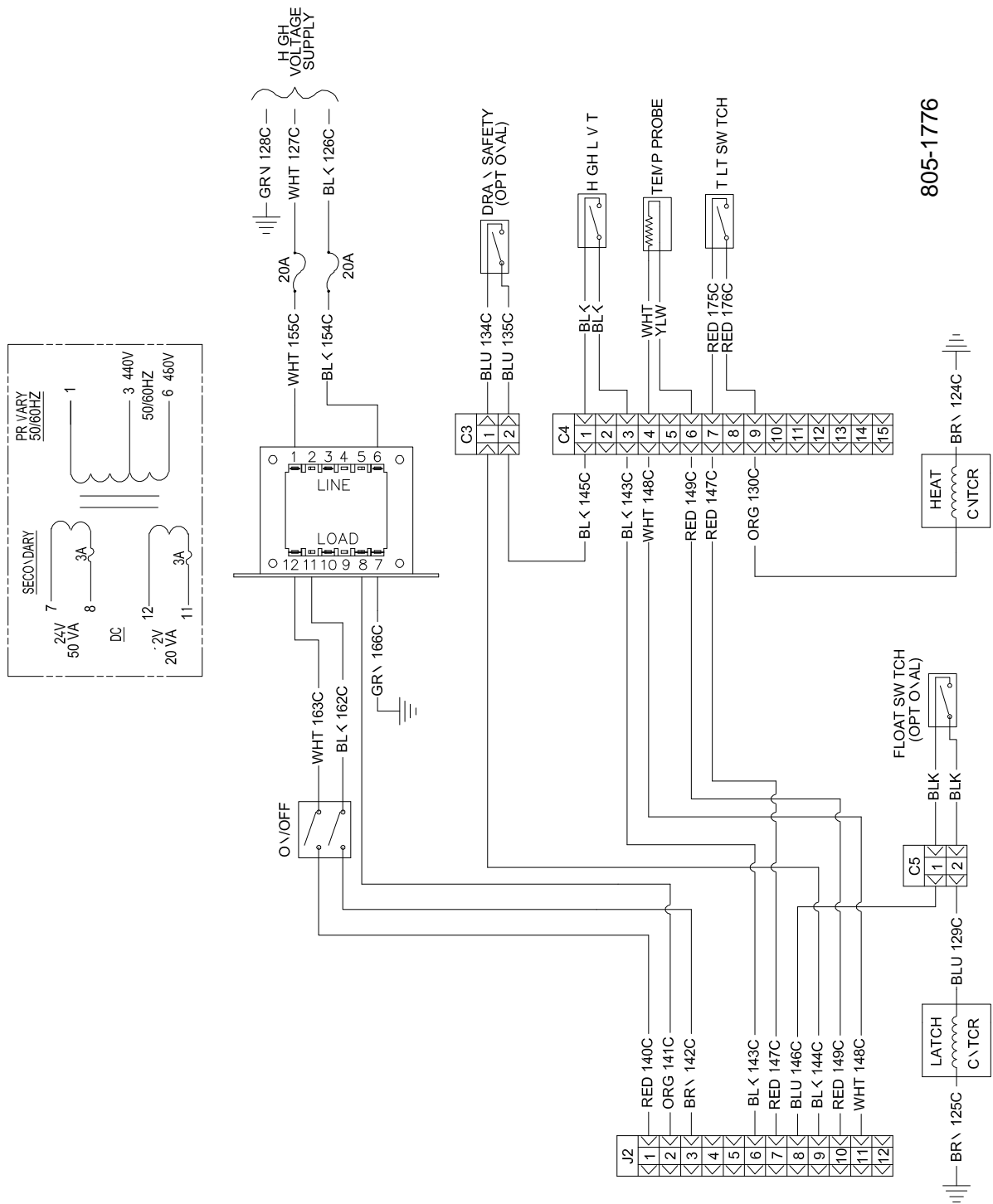

805-1776

### 1.13.7 Component Wiring - Fast Ready

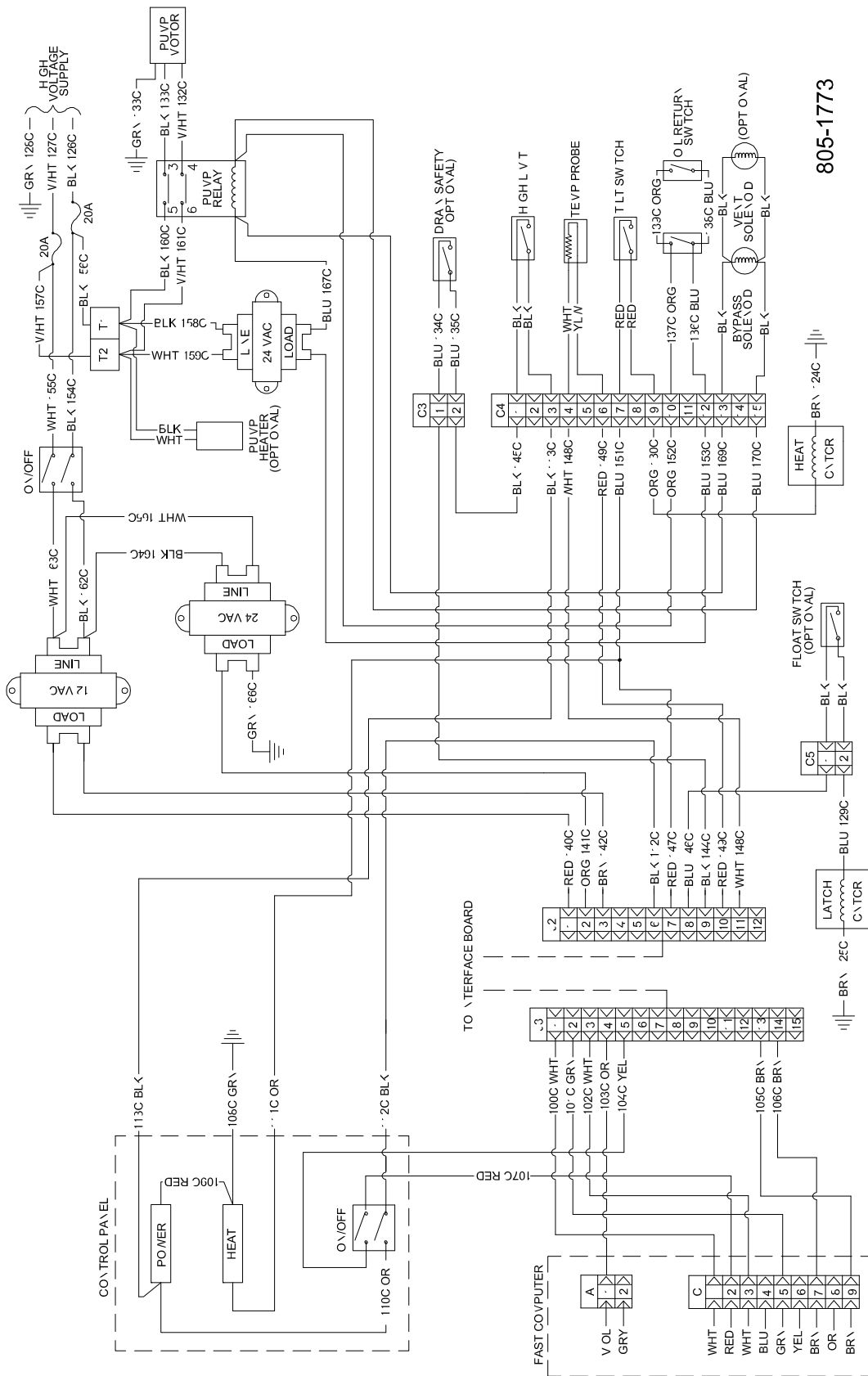

805-1773

### 1.13.8 Component Wiring – KFC INDIA K3000

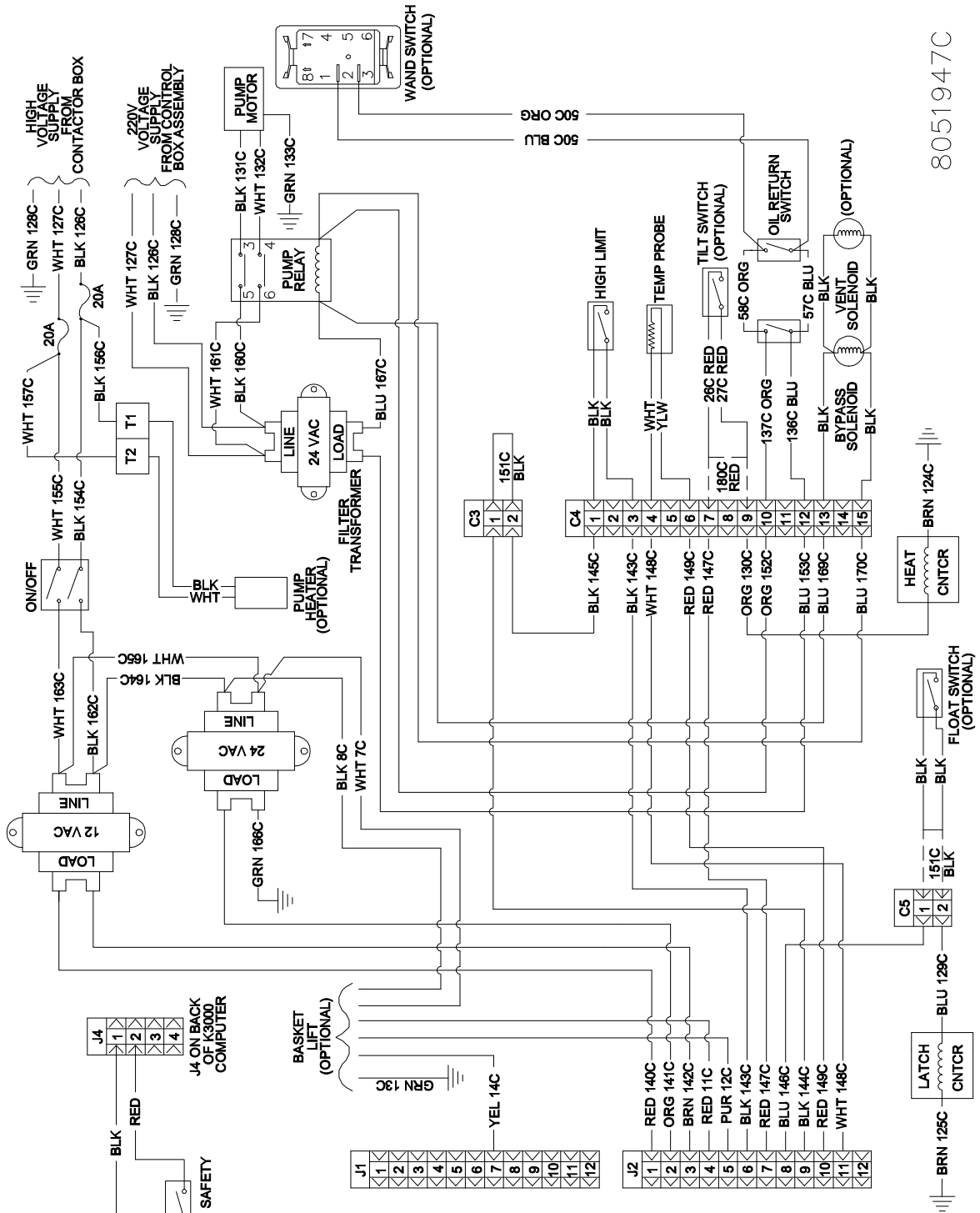

8051947C

### 1.13.9 Component Wiring – KFC INDIA FAST

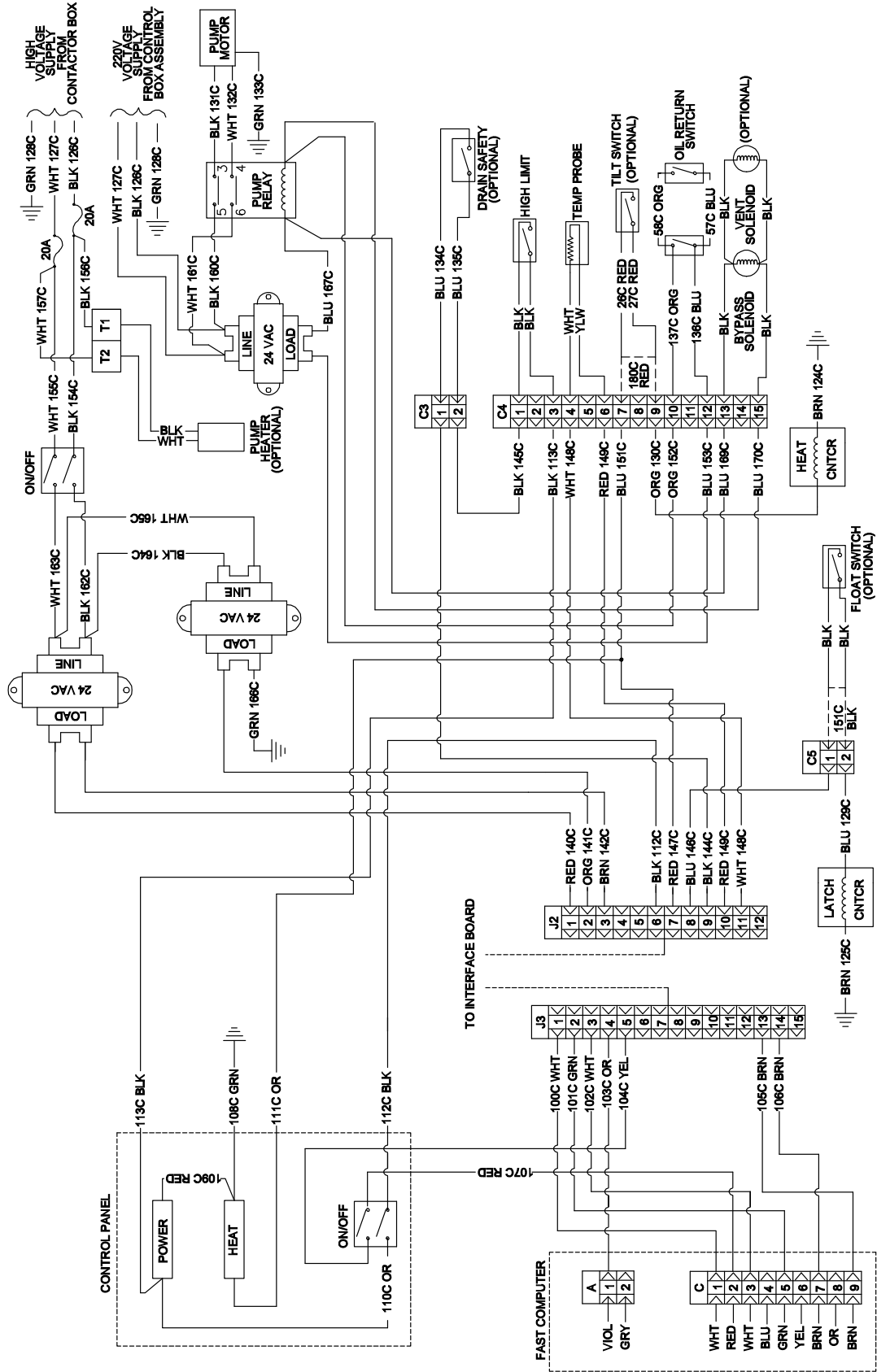

8051949C

### 1.13.10 Contactor Box – Domestic, 17 kW

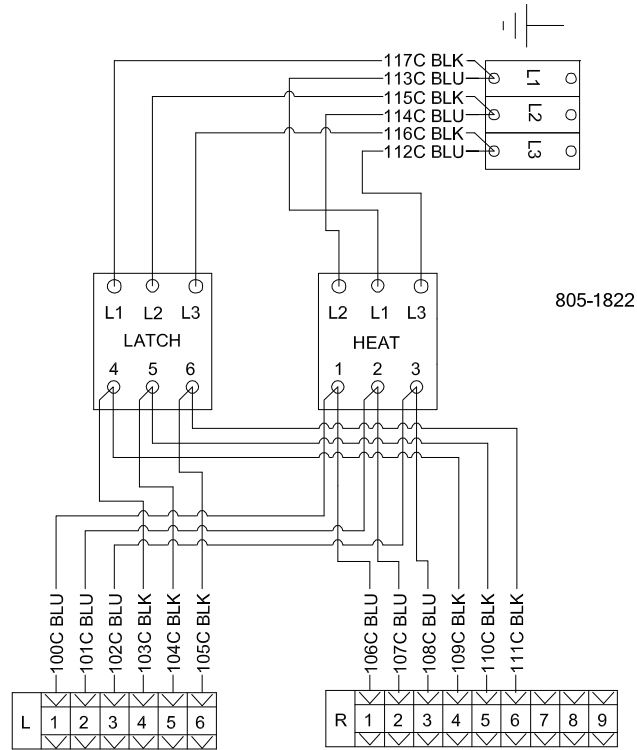

### 1.13.11 Contactor Box – Domestic, 21 kW

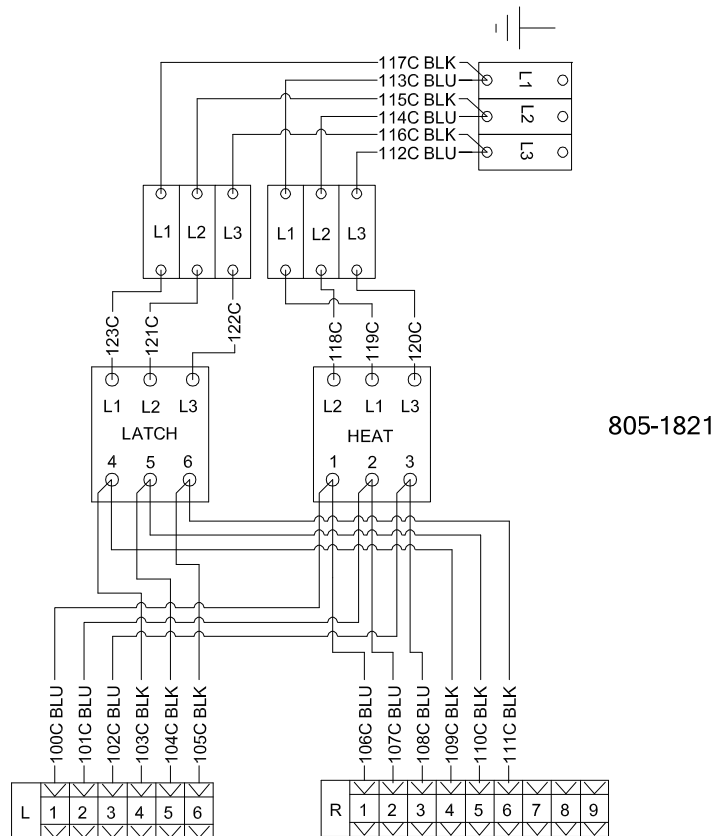

### 1.13.12 Contactor Box – Export 17kW and 21kW

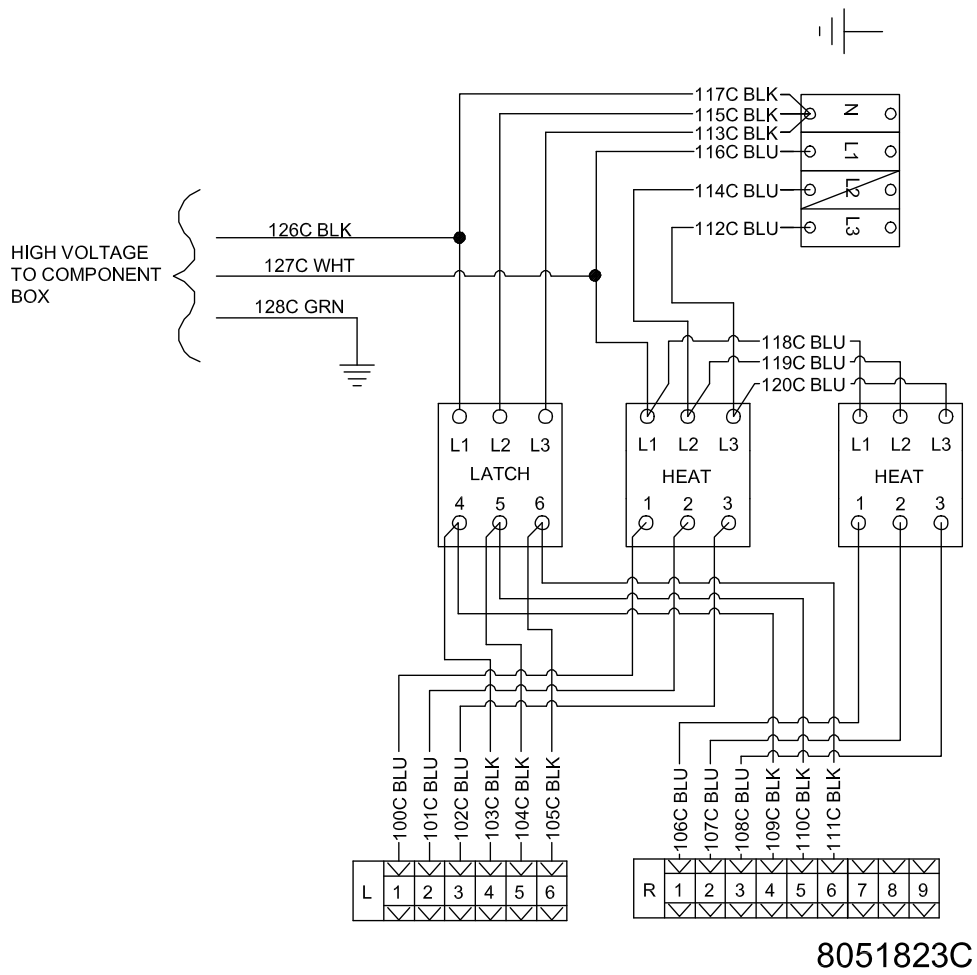

### 1.13.13 Contactor Box – Export (Chinese Foshan) 17kW and 21kW

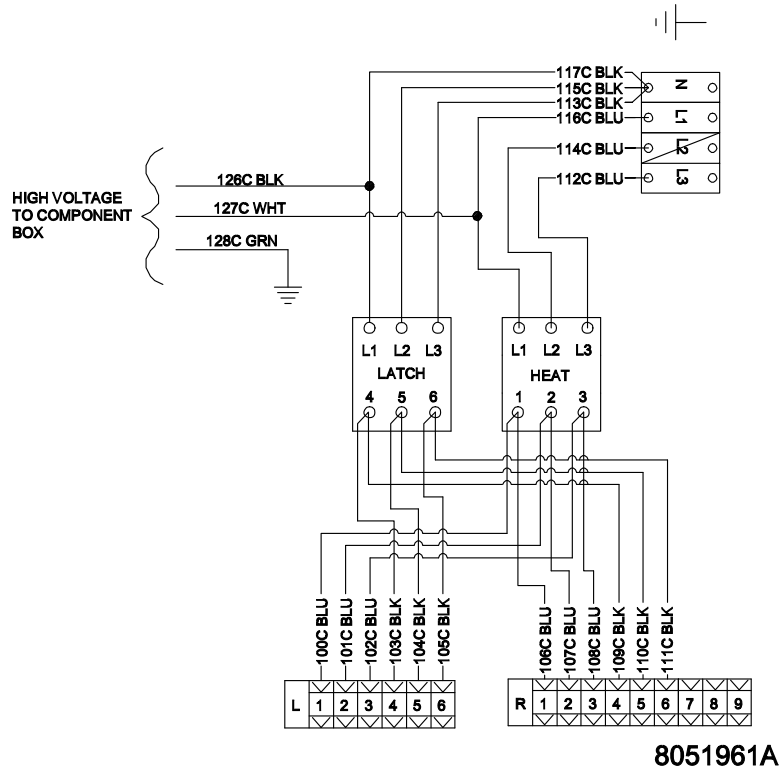

### 1.13.14 Contactor Box – Export KFC India 17kW

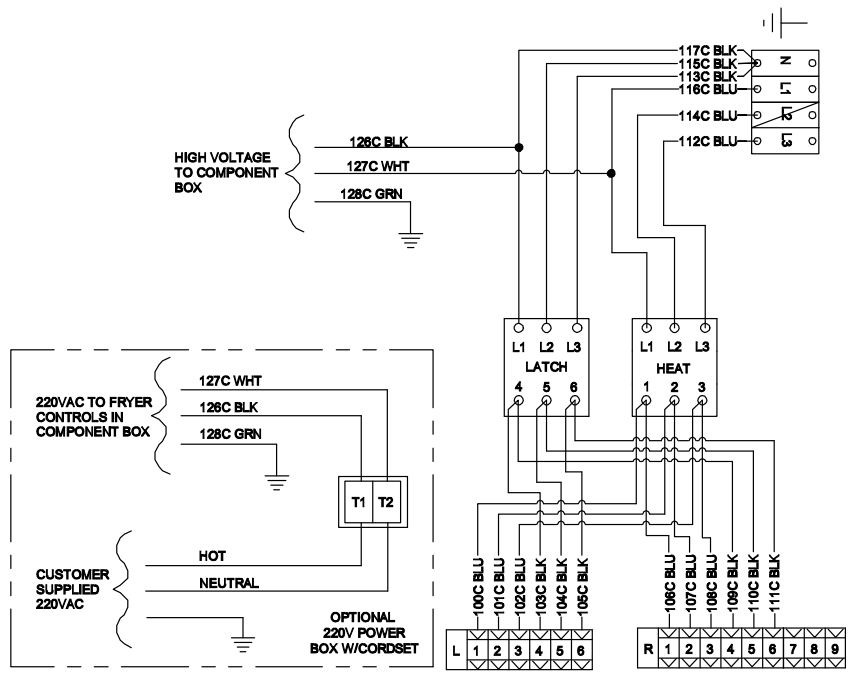



# E4 SERIES HIGH PRODUCTION RE ELECTRIC FRYERS

## CHAPTER 2: PARTS LIST

### 2.1 Accessories

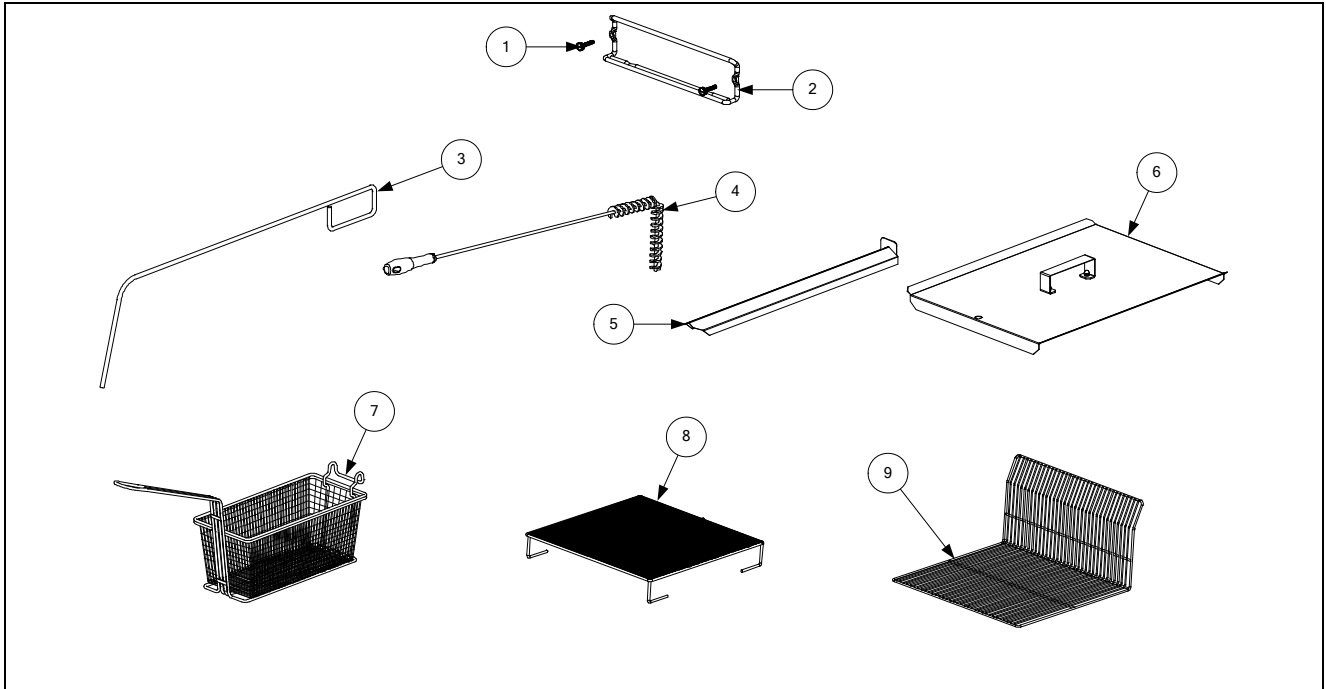

ITEM	PART #	COMPONENT
1	809-0985	Thumbscrew, ¼ -20 X 1⅜-inch
2	810-2794	Basket Hanger
*	230-4318	Basket Hanger, KFC
*	809-0941	Spacer, Basket Hanger
*	809-0905	Thumbscrew
3	803-0197	Cleanout Rod, 27-inch
4	803-0278	Brush, Teflon, L-shaped
5		Joiner Strip
	230-4766	Standard
	823-7922	Church's/Popeye's
	230-9451	KFC India
	230-5382	Battering Strip (Standard, 1 per 5-vat or 6-vat unit)
	823-7100	Battering Strip (Church's, 1 per 5-vat or 6-vat unit)
	823-6341	Caster Battering Plate
6	108-0220	Frypot Cover
*	108-0217	Frypot Cover, Church's
7	803-0304	Basket, Twin
8	803-0387	Grid, Basket Support
9	810-3066	Grid, Basket Support, Church's
*	803-0293	Gloves, Hot Oil/Neoprene (pair)
*	803-0342	Powder, Filter (25 count box)
*	823-7109	Splash Guard
*	823-7169	Splash Guard, Church's or Popeye's

\* Not illustrated.

## 2.2 Cabinetry

### 2.2.1 Back Panels, Tilt Housings, Top Caps, and Doors

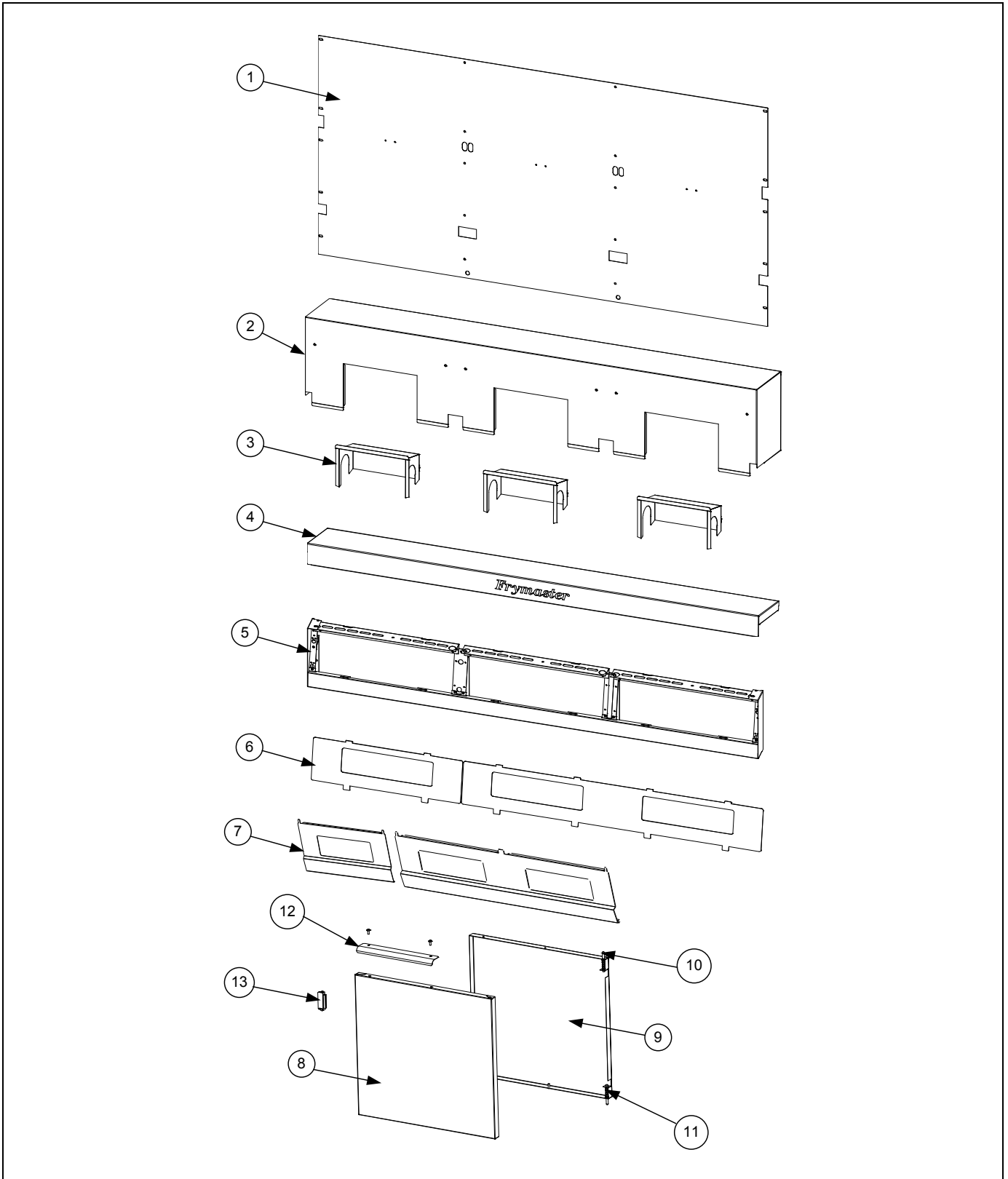

## 2.2.1 Back Panels, Tilt Housings, Top Caps, and Doors (cont.)

ITEM	PART #	COMPONENT
1		<b>Back, Cabinet</b>
		<b>Standard</b>
	240-0189	x1
	220-5034	x2, x4 (2), x5 (1)
	220-5149	x3, x5 (1), x6 (2)
	220-7582	<b>Single Filter Cabinet</b>
	240-0190	<b>With Basket Lift</b>
		<b>KFC with Over the Top Filtration</b>
	220-9416	x1
	240-0393	x2, x4 (2), x5 (1)
	240-0392	x3, x5 (1), x6 (2)
		<b>Church's/Popeye's</b>
	220-5313	x1
	220-5314	x2, x5 (1), x4 (2)
	220-5315	x3, x5 (1), x6 (2)
2		<b>Tilt Housing</b>
	823-7019	x1
	823-6947	x2
	823-6874	x3
	823-7022	x4
		<b>KFC with Over the Top Filtration</b>
	823-7014	x1
	823-6782	x2
	823-7133	x3
		<b>Church's/Popeye's</b>
	823-7072	x1
	823-7073	x2, x5 (1)
	823-7074	x3, x5 (1), x6 (2)
	823-7075	x4
3	823-5440	Cove, Element Tilt Housing
4		<b>Top Cap</b>
		<b>Frymaster</b>
	108-3141	x1
	108-3142	x2, x5 (1)
	108-3143	x3, x5 (1), x6 (2)
	108-3144	x4
		<b>Dean</b>
	108-0034	x1
	108-0040	x2, x5 (1)
	108-0042	x3, x5 (1), x6 (2)
	108-0036	x4
		<b>Church's/Popeye's</b>
	108-3364	x1
	108-3365	x2, x5 (1)
	108-3366	x3, x5 (1), x6 (2)
	108-3367	x4

\* Not illustrated.

## 2.2.1 Back Panels, Tilt Housings, Top Caps, and Doors (cont.)

ITEM	PART #	COMPONENT
5		<b>Control Frame</b>
		<b>Standard, Church's/Popeye's</b>
	108-5134	x1
	108-5320	x2, x5 (1)
	108-5381	x3, x5 (1), x6 (2)
	108-5380	x4
		<b>FAST</b>
	106-8427	x1
	106-7661	x2
106-9789	x3	
6		<b>Computer Bezel (Old Style)</b>
		<b>Standard</b>
	230-0489	x1, x3 (1), x5 (1)
	210-8175	x2, x3 (1), x4 (2), x5 (2), x6 (3)
		<b>KFC</b>
	230-5478	x1, x3 (1), x5 (1)
	230-5477	x2, x3 (1), x4 (2), x5 (2), x6 (3)
		<b>K3000</b>
	230-7720	x1, x3 (1), x5 (1)
	230-7721	x2, x3 (1), x4 (2), x5 (2), x6 (3)
230-4771	<b>With Switch Cut-out</b> (1 per wand connection for Church's/Popeye's)	
7		<b>Computer Bezel (New Unified Style)</b>
		<b>Standard</b>
	260-0406	x1,
	260-0460	x2, x4 (2), x5 (2),
	260-0502	x3, x5 (1), x6 (3)
	260-0508	x1, <b>(With Switch Cut-out on right for Church's/Popeye's)</b>
	260-0510	x2, x4 (2), x5 (2), <b>(With Switch Cut-out on right for Church's/Popeye's)</b>
	260-0512	x3, x5 (1), x6 (3) <b>(With Switch Cut-out on right for Church's/Popeye's)</b>
	260-0507	x1, <b>(With Switch Cut-out on Left)</b>
	260-0587	x1, Spreader Blank
		<b>KFC (FAST or F3000)</b>
	230-5480	x1, x2 (2), x3 (3), x4 (4), x5 (5), x6 (6)
		<b>3000 or KFC K3000</b>
	260-0410	x1,
	260-0430	x2, x4 (2), x5 (2),
	260-0503	x3, x5 (1), x6 (3)
	260-0509	x1, <b>(With Switch Cut-out on right for Church's/Popeye's)</b>
	260-0511	x2, x4 (2), x5 (2), <b>(With Switch Cut-out on right for Church's/Popeye's)</b>
	260-0513	x3, x5 (1), x6 (3) <b>(With Switch Cut-out on right for Church's/Popeye's)</b>
	106-4309	<b>Door, Left or Right</b> (Left shown – move handle to opposite side for Right) - Standard
106-8511	<b>Door, Left or Right</b> (Left shown – move handle to opposite side for Right) - KFC	
8	210-8075	Panel, Door (use 230-3730 for KFC)
9	200-8076	Panel, Liner
10	106-4067	Pin Assembly
11	810-0275	Spring, Door Hinge/Pin
12	210-8077	Handle (use 810-3335 for KFC)
13	810-2346	Magnet

\* Not illustrated.

## 2.2.2 Cabinets, Bases, Braces, and Associated Parts

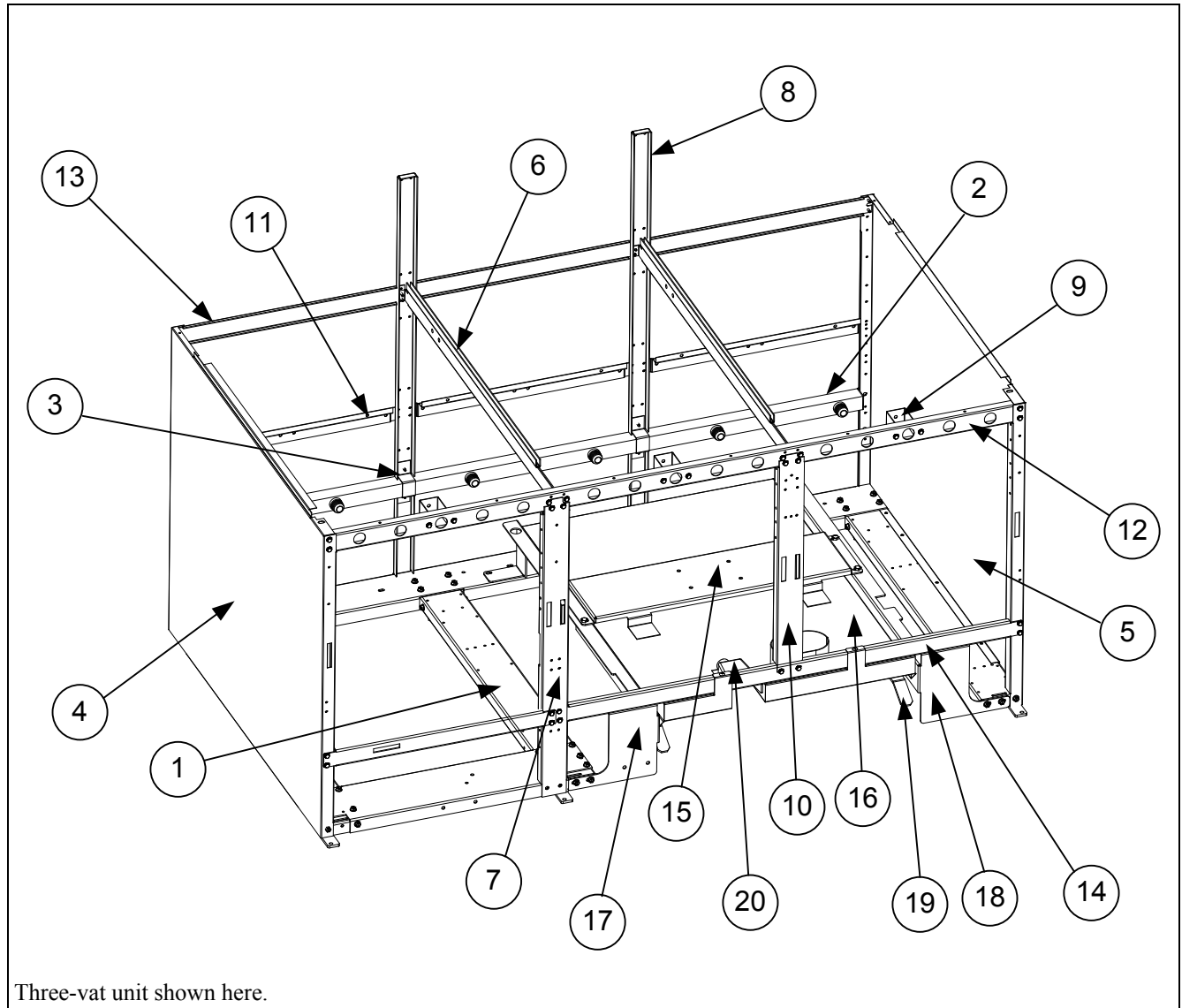

ITEM	PART #	COMPONENT
1		<b>Base Assembly</b>
	106-8224	x1, Filter Cabinet
	106-6534	x2, Filter Cabinet
	106-5622	x3, Filter Cabinet
	106-4424	x4, Filter Cabinet
	106-5622	x5, Filter Cabinet
	106-5622	x6, Filter Cabinet
	106-6643	x1, Non-filter Cabinet
	106-6436	x2, Non-filter Cabinet
	106-9425	x3, Non-filter Cabinet
2		<b>Oil Return Manifold</b>
	810-3118	x2, x5 (1)
	810-3121	x3, x5 (1), x6 (2)
	810-3120	x4
3	220-2082	Strap, Manifold Brace (x2, x3)

\* Not illustrated.

## 2.2.2 Cabinets, Bases, Braces, and Associated Parts cont.

ITEM	PART #	COMPONENT
		<b>Cabinet Sides</b>
4	231-4896	Side, Stainless Steel, Left
5	232-4896	Side, Stainless Steel, Right
	221-5073	Side, Painted, Left
	222-5073	Side, Painted, Right
	221-5170	Side, Inner, Left (x5 and x6 units)
	222-5170	Side, Inner, Right (x5 and x6 units)
6	220-5983	Divider (multi-vat units)
		<b>Post</b>
7	220-5112	Front (all x2, x4, x5, x6 units and x3 filter cabinet)
8	220-2250	Front (x3 non-filter cabinet)
9	220-5032	Rear, Standard
*	220-5210	Rear, Church's/Popeye's
10	220-4937	Brace, Frypot Locating
*	220-5979	Brace, Pump Motor Support
*	220-5490	Mount, Contactor Box (x1)
11	220-4860	Bracket, Lower Spring
12		<b>Brace, Upper Cabinet, Front</b>
	220-0274	x1
	200-9590	x2, x5 (1)
	220-0608	x3, x5 (1), x6 (2)
		x4
13		<b>Brace, Upper Cabinet, Rear</b>
	220-0274	x1
	220-1809	x2, x3, x4, x5, x6
14		<b>Brace, Lower Cabinet, Front</b>
	220-5267	x1
	220-4999	x2, x3 (1), x5 (1)
	200-8100	x3 (1), x4 (2), x5 (3), x6 (4)
		<b>Brace, Lower Cabinet, Rear</b>
	220-4570	x2
	220-4569	x3
15	824-1966	Bridge, Filter
16		Filter Pan Lid ( <i>see next section</i> )
17	221-2576	Rail, Left
18	222-2576	Rail, Right
19	823-3347	Frame, Slide Base
20	823-6450	Bracket, Disconnect
*	826-1115	Leg Assembly (includes 810-3168)
*	826-1118	Caster Assembly with Brake (includes 810-0357)
*	826-1117	Caster Assembly without Brake (includes 810-0356)
*	826-0900	Chain Restraint Kit (required for all caster installations)

\* Not illustrated.

## 2.2.3 Basket Lift Assembly and Associated Parts

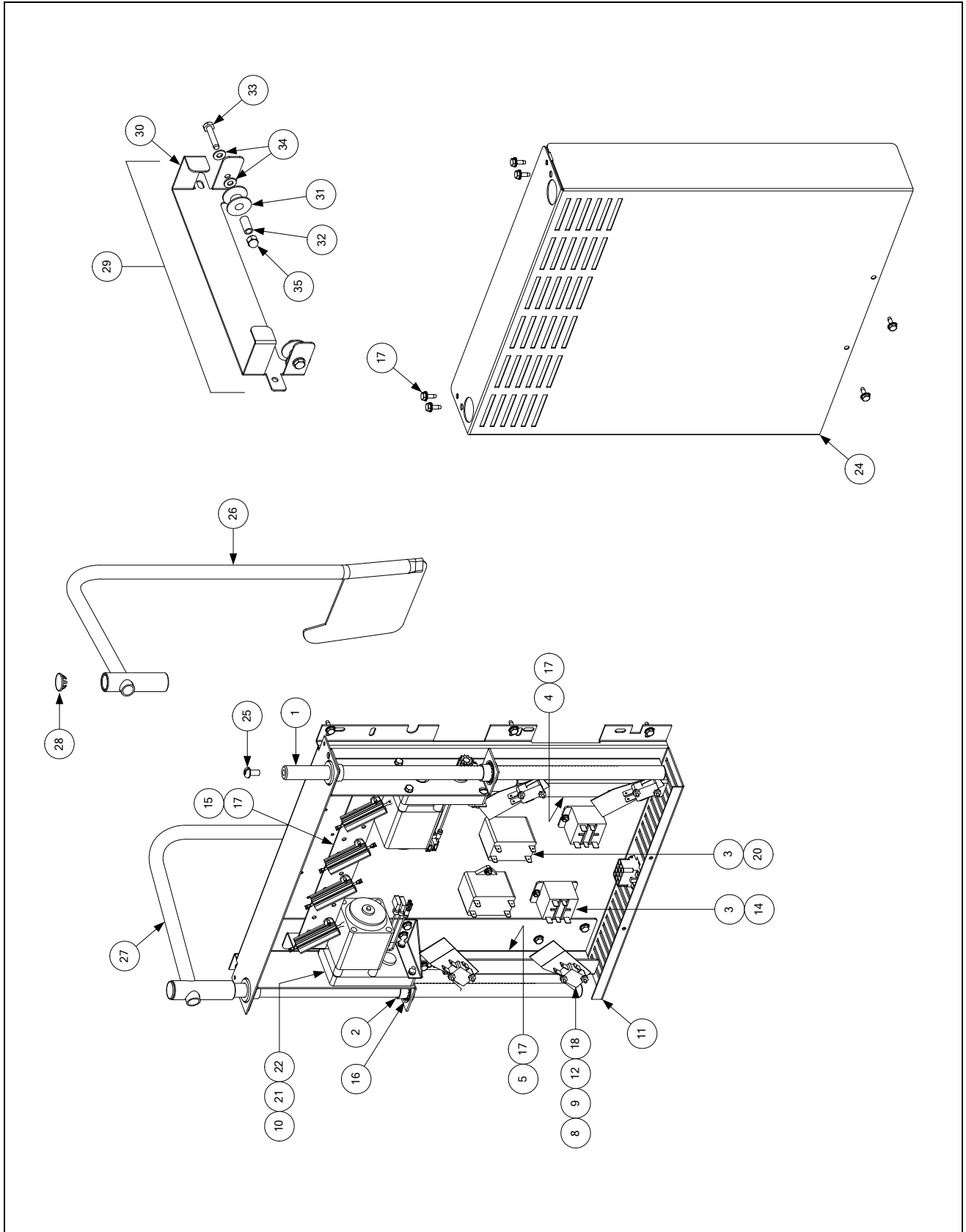

### 2.2.3 Basket Lift Assembly and Associated Parts (cont.)

ITEM	PART #	COMPONENT
	106-3775	<b>Basket Lift Assembly, 100-120VAC</b>
	106-4147	<b>Basket Lift Assembly, 208-220VAC</b>
	106-4148	<b>Basket Lift Assembly, 230-240VAC</b>
1	810-1012	Rod, Basket Lift
2	813-0035	Bushing, Bronze
3	807-2513	Capacitor, 12.5 $\mu$ Farad 330VAC
4	901-8499	Chassis, Left Basket Lift
5	902-8499	Chassis, Right Basket Lift
6	807-0159	Connector, 12-Pin Female
7	900-5529	Gusset, Basket Lift Motor
8	812-0442	Insulation, Microswitch
9	807-2572	Microswitch
10	806-5964SP	Motor Assembly, 208-240VAC Modular Basket Lift
11	200-6455	Mount, Modular Basket Lift
12	826-1366	Nut, 4-40 Hex Keps (Pkg. of 25)
13	809-0247	Nut, 8-32 Hex Keps
14	807-1683	Relay, 12VDC
15		<b>Resistor Assembly</b>
	806-8530SP	100-120VAC Modular Basket Lift
	106-2770SP	208-220VAC Modular Basket Lift
	106-2771SP	230-250VAC Modular Basket Lift
16	809-0082	Ring, Bushing Retainer
17	826-1374	Screw, #10 X 1/2-inch Hex Washer Head (Pkg. of 25)
18	826-1359	Screw, 4-40 X 3/4-inch Slotted Round Head (Pkg. of 25)
19	826-1361	Screw, 8-32 X 1-inch Slotted Truss Head (Pkg. of 25)
20	826-1371	Screw, #8 X 1/2-inch Drill Point Hex Head (Pkg. of 25)
21	809-0503	Screw, 8-32 X 1/2-inch Hex Head
22	809-0186	Washer, #8 Lock
23	WIR-0166SP	Wire Bundle, 200-250VAC Basket Lift w/Relay
24	200-6454	Cover, Modular Basket Lift Rear
25	809-0127	Screw, 1/4-20 X 1/2-inch Slotted Round Head
26	823-7993	Arm, Left Basket Lift
27	823-7994	Arm, Right Basket Lift
28	810-0179	Button, Plug
29	108-0617	<b>Roller Assembly, Basket Lift</b>
30	823-7188	Bracket, Basket Lift Roller
31	810-0194	Roller, Basket Lift
32	810-0374	Spacer, Basket Lift Roller
33	809-0508	Bolt, 1/4-20 X 1 1/4 -Inch
34	809-0190	Washer, 1/4-inch Flat
35	809-0990	Nut, 1/4-20 Crown Acorn
*	108-2649	Wiring Harness, Basket Lift
*	824-1353	Basket Lift Drip Weldment, Right
*	824-1351	Basket Lift Drip Weldment, Left

\* Not illustrated.



### 2.3.1 Filter Pan Assemblies

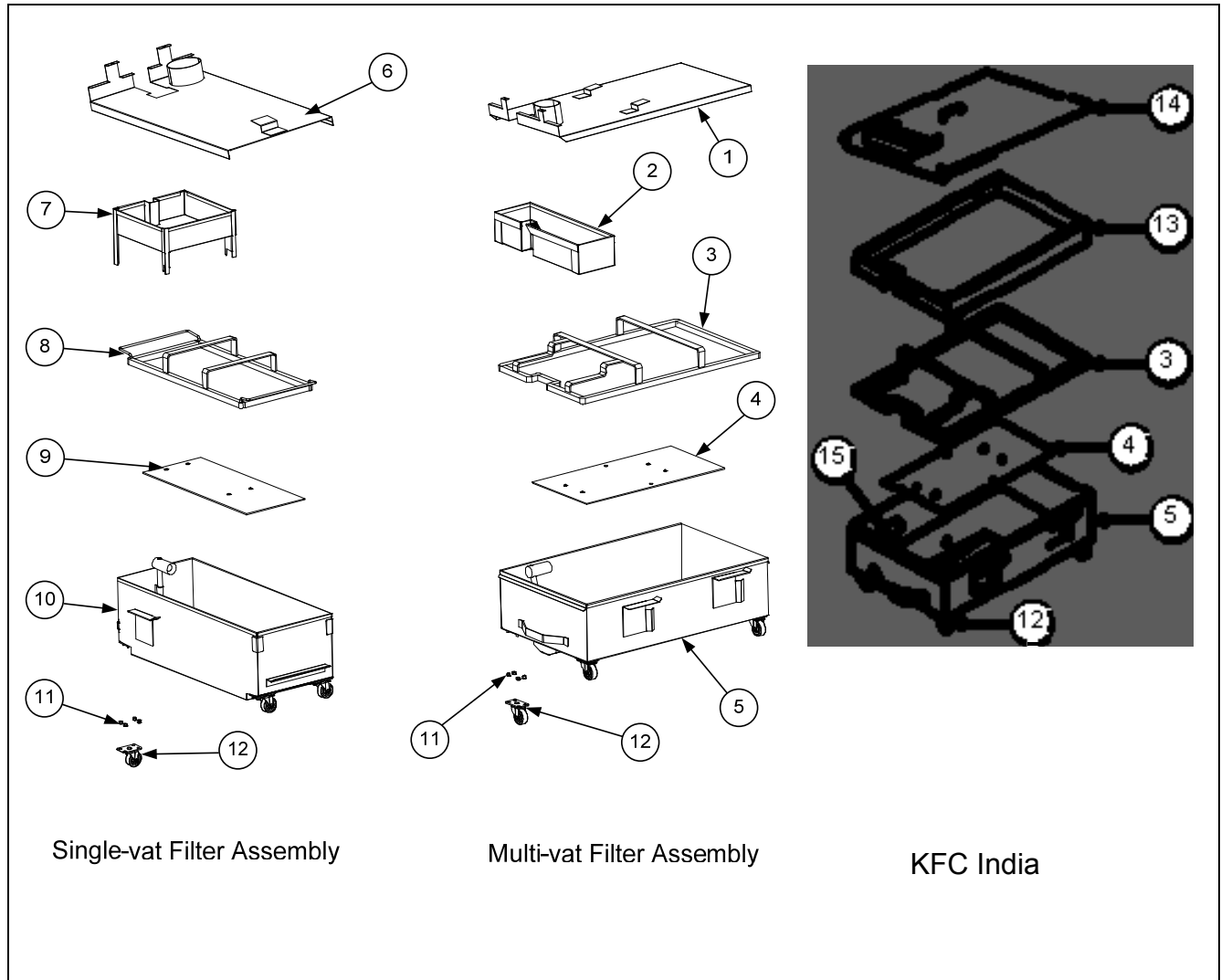

ITEM	PART #	COMPONENT
	106-7674SP	<b>Filter Assembly, Multi-vat, Paper Filtration</b>
1	823-6943	Lid, Filter Pan
2	823-6172	Crumb Basket
3	810-3195	Hold-down Ring
4	106-7330	Sana Grid
5	823-7534	Filter Pan
	108-0253	<b>Filter Assembly, Multi-vat, Screen Filtration</b>
*	823-6466	Crumb Basket
*	810-2350	Filter Screen/Leaf
*	823-7112	Suction Tube
*	810-2583	Fitting, Bottom, Filter Screen/Leaf
*	810-2582	Fitting, Bulk Head, Filter Screen/Leaf
*	823-7111	Filter Pan

\* Not illustrated.

### 2.3.1 Filter Pan Assemblies (cont.)

ITEM	PART #	COMPONENT
	106-8398	<b>Filter Assembly, Single-vat, Paper Filtration</b>
6	823-6508	Lid, Filter Pan
7	823-7386	Crumb Basket
8	810-3328	Hold-down Ring (use 812-2195 for use with 803-0173 filter paper)
9	108-1029	Sana Grid
10	823-7359	Filter Pan
11	809-0823	Nut
12	810-2805	Caster
	108-2428	<b>Filter Assembly, Multi-vat, Paper Filtration KFC India</b>
13	823-7904	Crumb Basket
14	823-8571	Lid, Filter Pan
15	813-0568	Pipe, Plug 1/8 NPT
*	826-1979	Roller Kit ( <i>includes 4 rollers, 4 nuts and 4 lock washers</i> )

\* Not illustrated.

### 2.3.2 Filter Pump

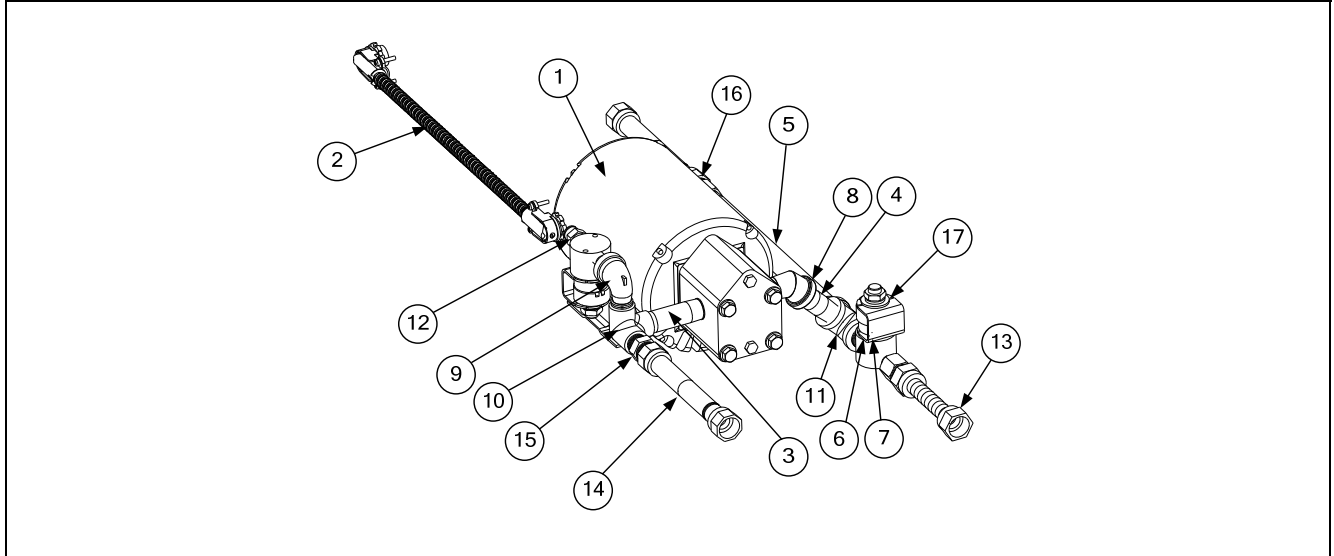

ITEM	PART #	COMPONENT
1		<b>Filter Pump Components</b>
	816-0093	Pump Gasket
	826-3192	8 GPM Pump
	826-3191	4 GPM Pump
	826-1712	120V Filter Motor, Gasket
	826-1756	208V Filter Motor, Gasket
	826-1270	220-240V Filter Motor, Gasket
	809-1020	Cap Screw to Connect Pump to Motor
2	106-9918	Harness Assembly, Filter Pump
3	813-0265	Nipple, 1/2" x 2.5" NPT BM
4	813-0298	Nipple, 1/2" x 2.0" NPT BM
5	813-0698	Nipple, 1/2" x 10.5" NPT BM
6	813-0838	Nipple, 1/4" NPT BM, Close
7	813-0304	Bushing, 1/2" x 1/4" BM, Flush
*	813-0763	Bushing, 3/4" OD x 1/2" ID NPT, Flush
*	813-0889	Elbow, 1/2", 90°
8	813-0342	Elbow, Street, 45°, 1/2"NPT
9	813-0165	Elbow, Street, 1/2" x 1/2" NPT, 90° BM
10	813-0331	Elbow, Side Outlet, 1/2" NPT
11	813-0003	Tee, 1/2" x 1/2" x 1/2" BM
12	810-3257	Fitting, 1/4" NPT
13	810-1339	Flexline, 5/8" x 4.5" Long
14	810-1680	Flexline, 5/8" OD x 4.5" Long
15	810-1668	Adaptor, Male, 5/8" OD x 1/2"
16	810-1669	Adaptor, Female, 7/8" OD x 1/2"
17	106-3470	Solenoid Valve (with Female Pins)
*	813-0436	Plug, 1/2" Counter Sink

\* Not illustrated.

## 2.4 Drain System Components

### 2.4.1 Drain Valve Assemblies

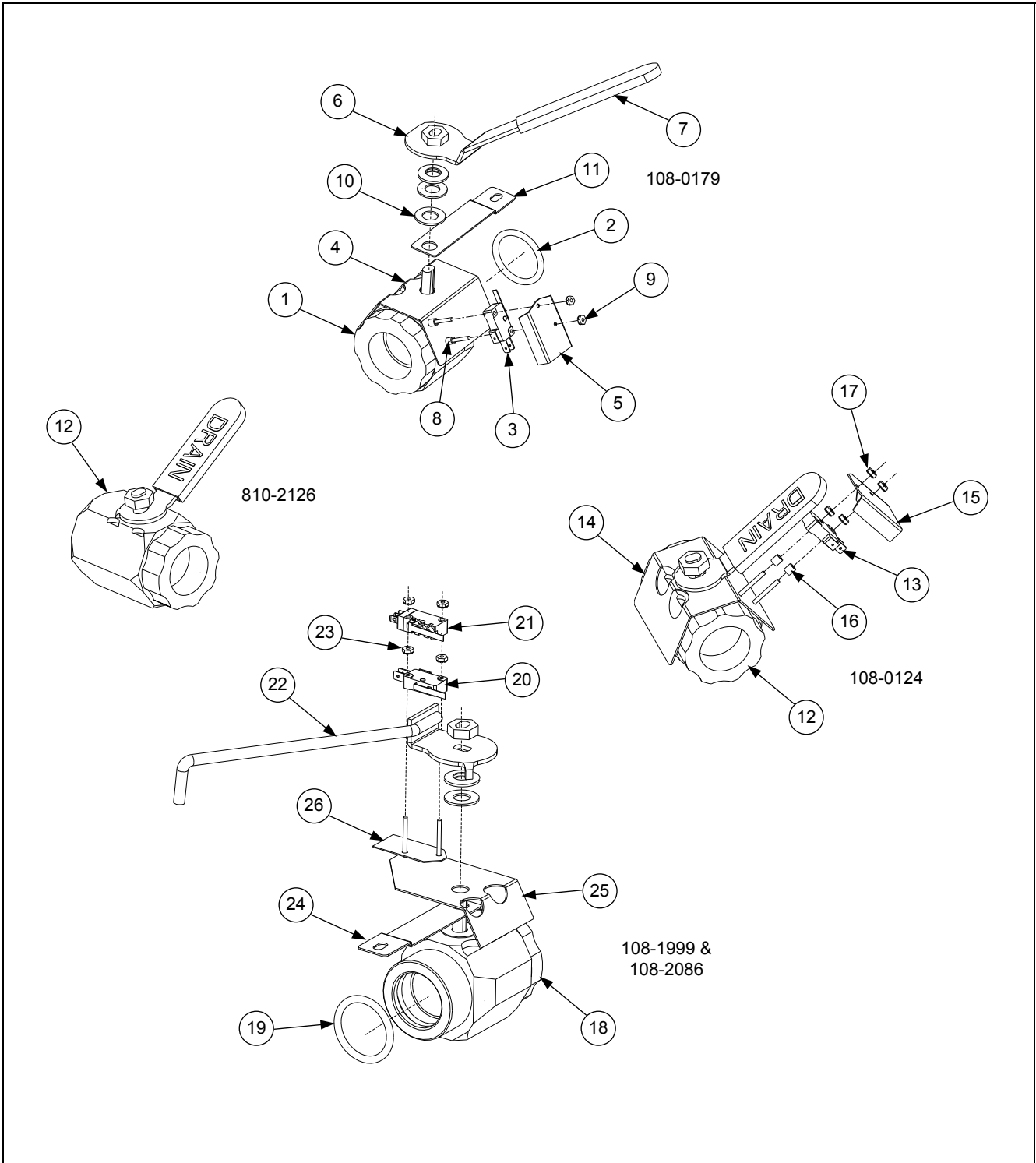

## 2.4.1 Drain Valve Assemblies (cont.)

ITEM	PART#	COMPONENT
<b>Drain Valve (units equipped with filtration)</b>		
1	810-2783	Valve, 1 ½" Full Port
2	816-0544PK	O-ring (pack of 5)
3	807-2103	Microswitch, Straight Lever, Drain Safety Switch
4	106-3745	Bracket, Drain Safety Switch
5	200-5694	Cover, Drain Safety Switch
6	210-7077	Handle (multi-vat unit)
*	230-7413	Handle (single unit)
7	816-0405	Sleeve, Drain Handle, Red
8	809-0349	Spacer, 4.0 mm x 6.0 mm
9	809-0237	Nut, 4-40 Keps Hex (with extended teeth)
10	809-0988	Washer, 1" x .525" ID, Teflon
11	200-6116	Strap, Drain Valve Connecting, 1 ½" (single unit)
<b>Drain Valve (units NOT equipped with filtration)</b>		
12	810-2126	Valve, 1 ¼" Full Port
13	807-2103	Microswitch, Straight Lever, Drain Safety Switch
14	106-9017	Bracket, Drain Safety Switch
15	901-2348	Cover, Drain Safety Switch
16	809-0349	Spacer, 4.0 mm x 6.0 mm
17	809-0237	Nut, 4-40 Keps Hex (with extended teeth)
<b>Drain Valve (K3000)</b>		
18	810-2783	Valve, 1 ½" Full Port
19	816-0544PK	O-ring (pack of 5)
20	807-2103	Microswitch, Straight Lever, Drain Safety Switch
21	807-4936	Microswitch, Gold Plated, Sealed
22	823-7749	Handle
23	809-0237	Nut, 4-40 Keps Hex (with extended teeth)
24	200-6116	Strap, Drain Valve Connecting, 1 ½" (single unit)
25	108-2006	Stud Assembly
26	816-0220	Insulation, Drain Safety Switch
<b>Drain Safety Harness</b>		
*	106-9924	Standard
*	106-0966	KFC1/CM4S
*	807-5159	K3000
*	106-7718	Wire Assembly, Jumper (for units with no float switch or drain switch)

\* Not illustrated.

## 2.4.2 Drain System Plumbing

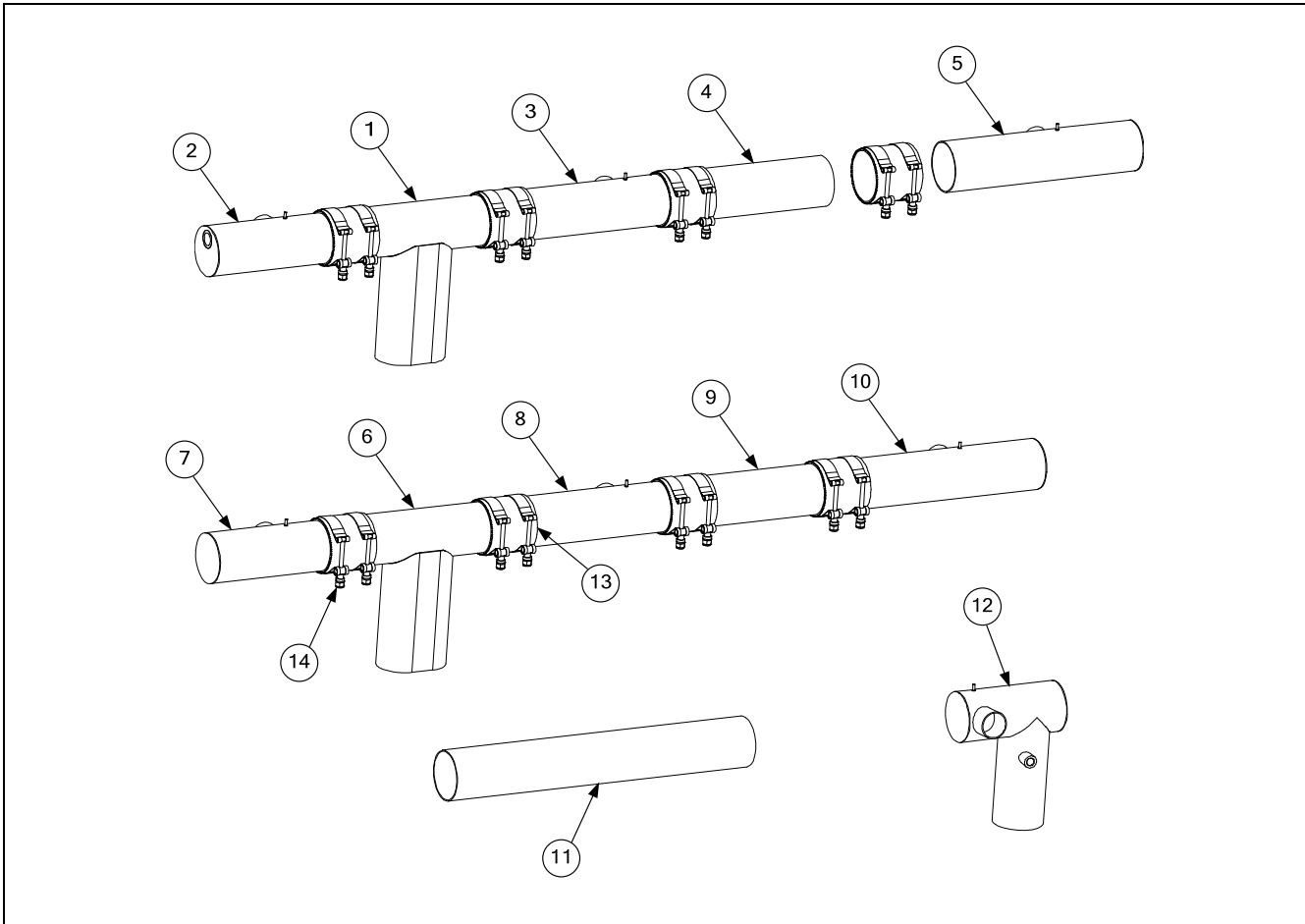

ITEM	PART#	COMPONENT
<b>Drain Plumbing</b>		
<b>With Drain Flush</b>		
1	812-2078	Downspout, Center
2	823-4681	Right, 8" Long (with coupling)
3	823-5188	Right, 10.5" Long
4	200-9365	Right, 9" Long (no drain connection)
5	823-4844	Left, 12.5" Long (with coupling)
<b>Without Drain Flush</b>		
6	812-2078	Downspout, Center
7	823-7016	Right, 8" Long
8	823-5188	Right, 10.5" Long
9	200-9365	Right, 9" Long (no drain connection)
10	823-7015	Left, 12.5" Long
*	823-4844	Left, 12.5" Long (with coupling)
11	200-6615	9" Long (no drain connection)
12	812-2131	Downspout, Multi-height
13	816-0772	Sleeve, Drain Connecting
14	809-0969	Clamp, T-bolt
*	816-0665	Vinyl Cap
*	812-1226	Drain Extension, 1.25-inch
*	220-5944	Drain Support (for spreader cabinets)

\* Not illustrated.

## 2.5 Oil Return System Components

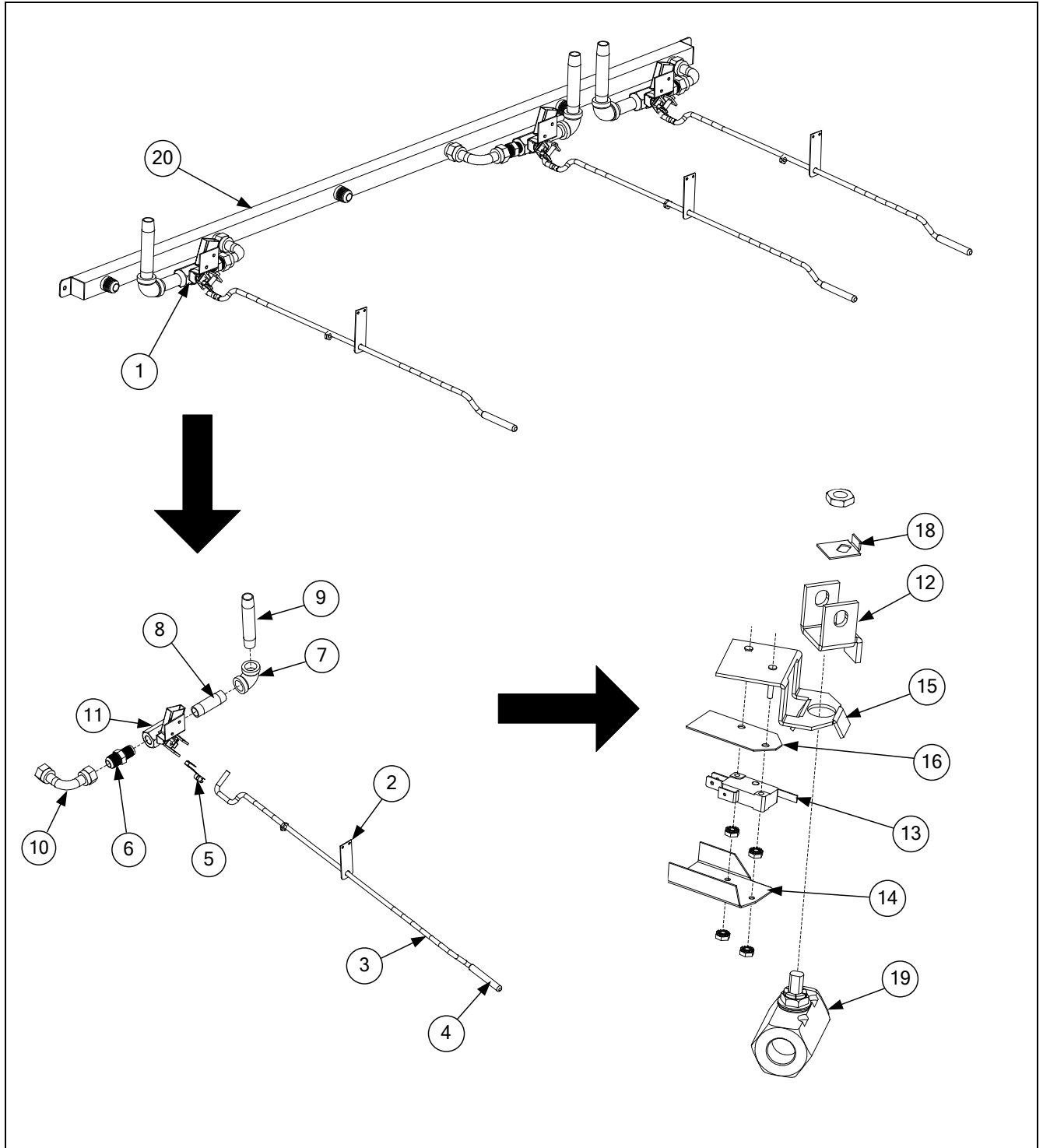

## 2.5 Oil Return System Components (cont.)

ITEM	PART #	COMPONENT
1		<b>Oil Return Plumbing Assembly</b>
	106-9711	<b>Left Assembly</b>
	106-9712	<b>Right Assembly</b>
	108-0717	<b>Single Assembly</b>
*	106-9928	Rear Harness
*	106-4182	Jumper Harness
2	220-4955	Handle Mount
3	200-8929	Handle, Oil Return
4	816-0638	Vinyl Cap, Yellow
*	816-0637	Vinyl Cap, Blue
5	809-0601	Clevis Clip, Rod End
6	810-1668	Adapter, Male, 5/8" OD x 1/2"
7	813-0062	Elbow, 1/2", 90° BM
*	813-0165	Elbow, Street, 1/2 NPT, 90° BM
8	813-0265	Nipple, 1/2 NPT x 2 1/2" BM
*	813-0087	Nipple, 1/2 NPT x 1 1/2" BM
*	813-0247	Nipple, 1/2 NPT x 3.5" BM
9	813-0281	Nipple, 1/2 NPT x 5" BM
10	810-1067	Flexline, 8.5"
*	813-0003	Tee, 1/2 NPT BM
11	106-4006	<b>Valve Assembly</b>
12	901-2772	Handle
13	807-2103	Microswitch, Straight Lever
14	220-2459	Cover, Drain Safety Switch
15	106-3962	Bracket Assembly, Microswitch
16	816-0220	Insulation, Oil Return Microswitch
17	826-1366	Nut, 4-40 Keps Hex (Pkg. of 25)
18	900-2935	Retainer, Nut
19	810-0278	Valve, 1/2" Ball
20		<b>Oil Return Manifold</b>
	810-4191	x2, x5 (1), x6 (1) Church's
	810-4192	x3, x5 (1), x6 (2)
	810-4232	x4, x6 (1) Church's

\* Not illustrated.



## 2.5.1 Oil Disposal Wand

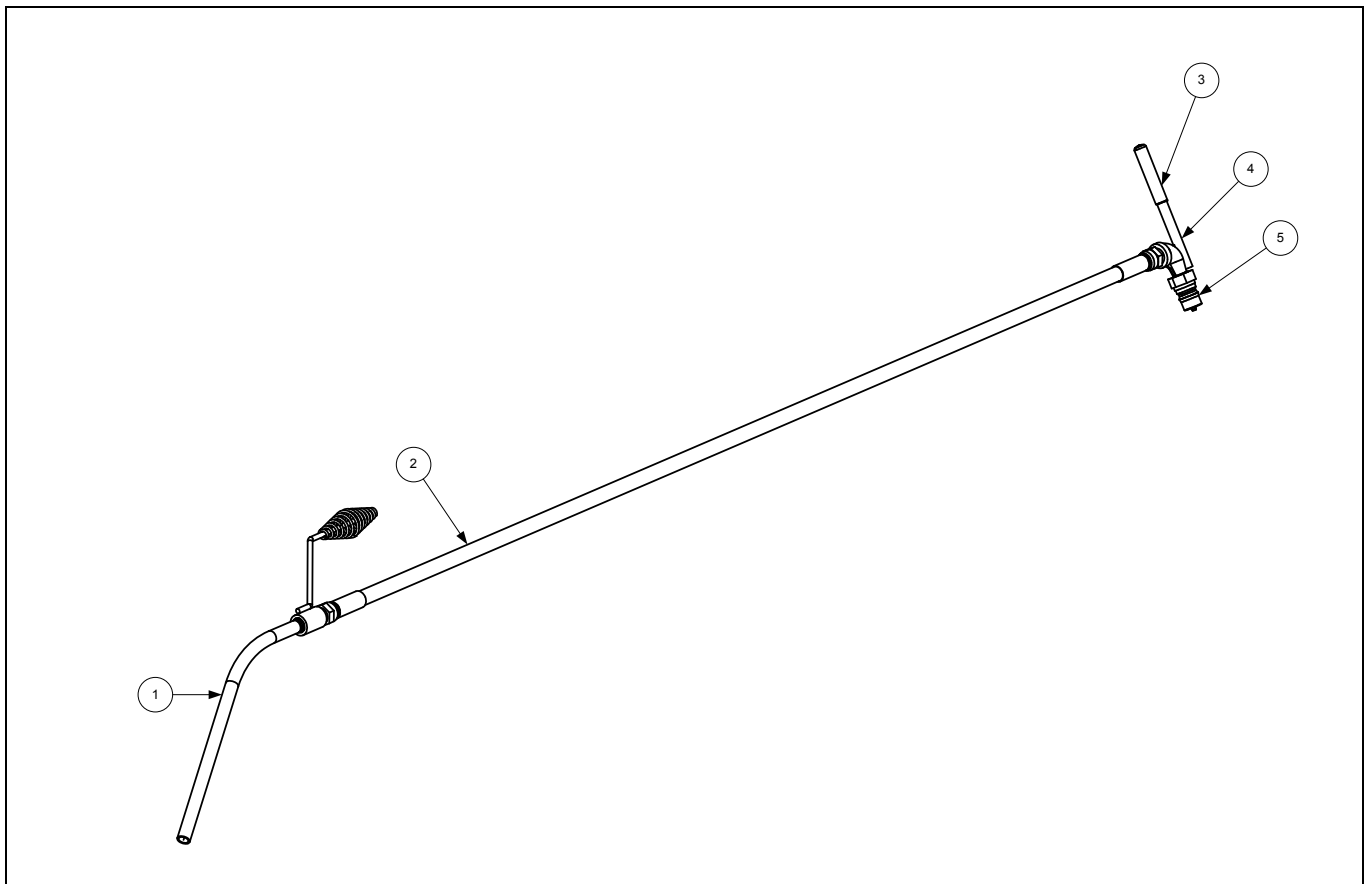

ITEM	PART #	COMPONENT
	108-0528	<b>Oil Disposal Wand Assembly</b>
1	106-1454	Nozzle assembly with handle
2	810-1434	Hose assembly
3	816-0631	Cap, red vinyl
4	823-7153	Handle
5	810-0487	Coupling

\* Not illustrated.

## 2.5.2 Over-the-Top Oil Return (KFC)

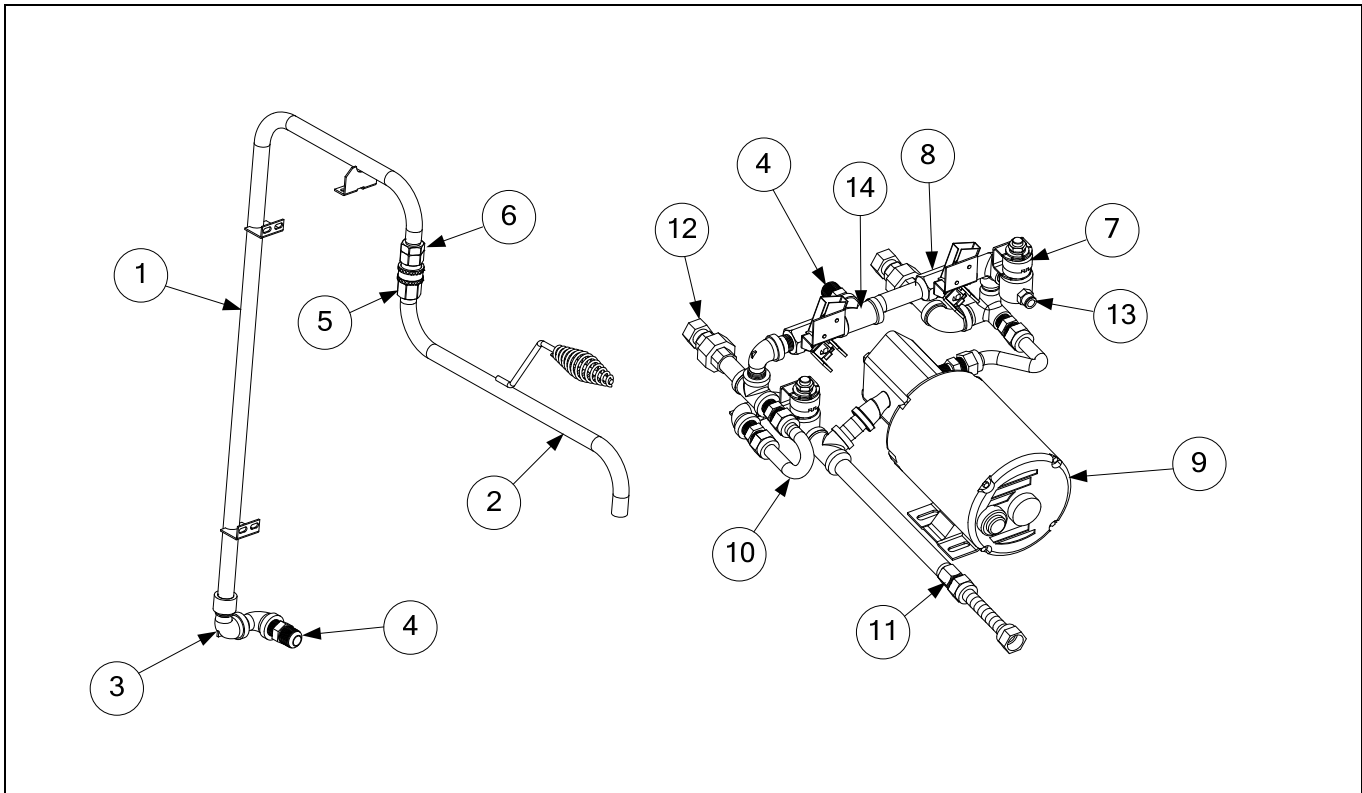

ITEM	PART #	COMPONENT
	106-9693	<b>Plumbing Assembly</b>
1	810-3468	Tubing, Over the Top
2	810-2513	Tubing, Faucet Upper
3	813-0165	Elbow, Street, 1/2" x 1/2" NPT, 90°
4	810-1668	Adapter, Male, 5/8" OD x 1/2"
5	810-2700	Nipple, Quick Disconnect
6	810-2699	Coupling, Quick Disconnect
7	106-3470	Valve, Solenoid, Female Pins
8	106-4006	Valve, 1/2" Oil Return
9	826-1712	120V Motor, Gasket
*	826-2789	8 GPM Pump
10	810-1159	Flexline, 5" Oil Return
11	810-1669	Adapter, Female, 7/8 OD x 1/2"
12	810-3160	Adaptor, 1/2" NPT x 15
13	810-3257	Fitting, 1/4" NPT, 3/8" OD
14	813-0003	Tee, 1/2" x 1/2" BM
*		<b>Oil Return Manifold</b>
*	810-4193	x1
*	810-4191	x2
*	810-4192	x3

\* Not illustrated.

## 2.5.3 Drain Flush Plumbing

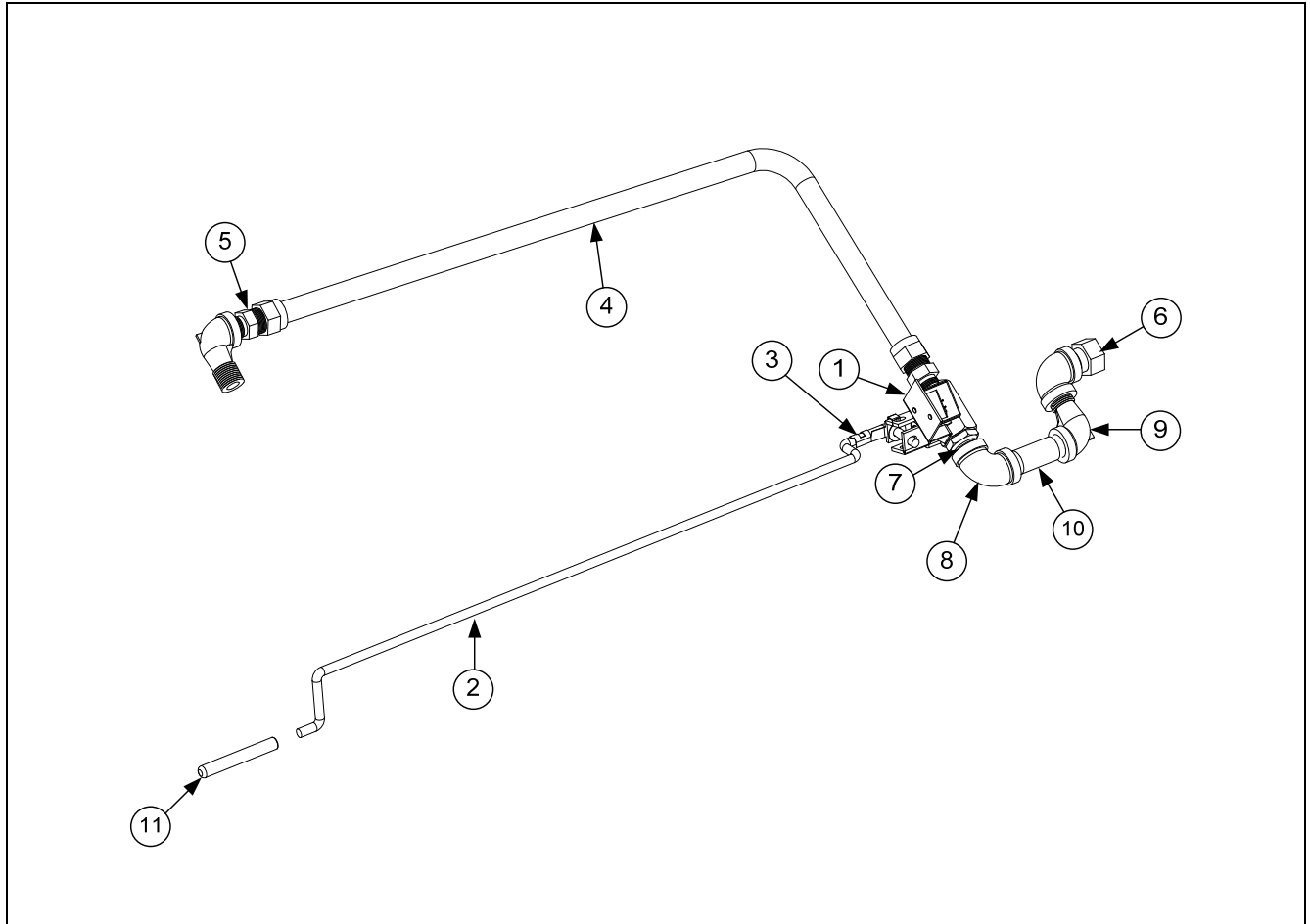

ITEM	PART #	COMPONENT
1	106-4006	Valve Assembly, Oil Return, 1/2"
2	200-8929	Handle, Oil Return
3	809-0601	Clevis Clip, Rod End
4	810-1069	Flexline, 5/8" x 29.50" Long
5	810-1668	Adapter, Male 5/8" OD x 1/2"
6	810-3160	Adapter, 1/2" NPT
7	813-0022	Nipple, 1/2" x Close NPT BM
8	813-0062	Elbow, 1/2", 90
9	813-0165	Elbow, Street, 1/2" x 1/2" NPT, 90 BM
10	813-0460	Nipple, 1/2" x 3.00 NPT BM
11	816-0637	Cap, Vinyl, Blue
*	220-4955	Handle Mount
*	106-9929	Wiring Harness, Drain Flush

\* Not illustrated.

## 2.6 Heating Element Assemblies and Associated Parts

### 2.6.1 Element Assemblies and Hardware

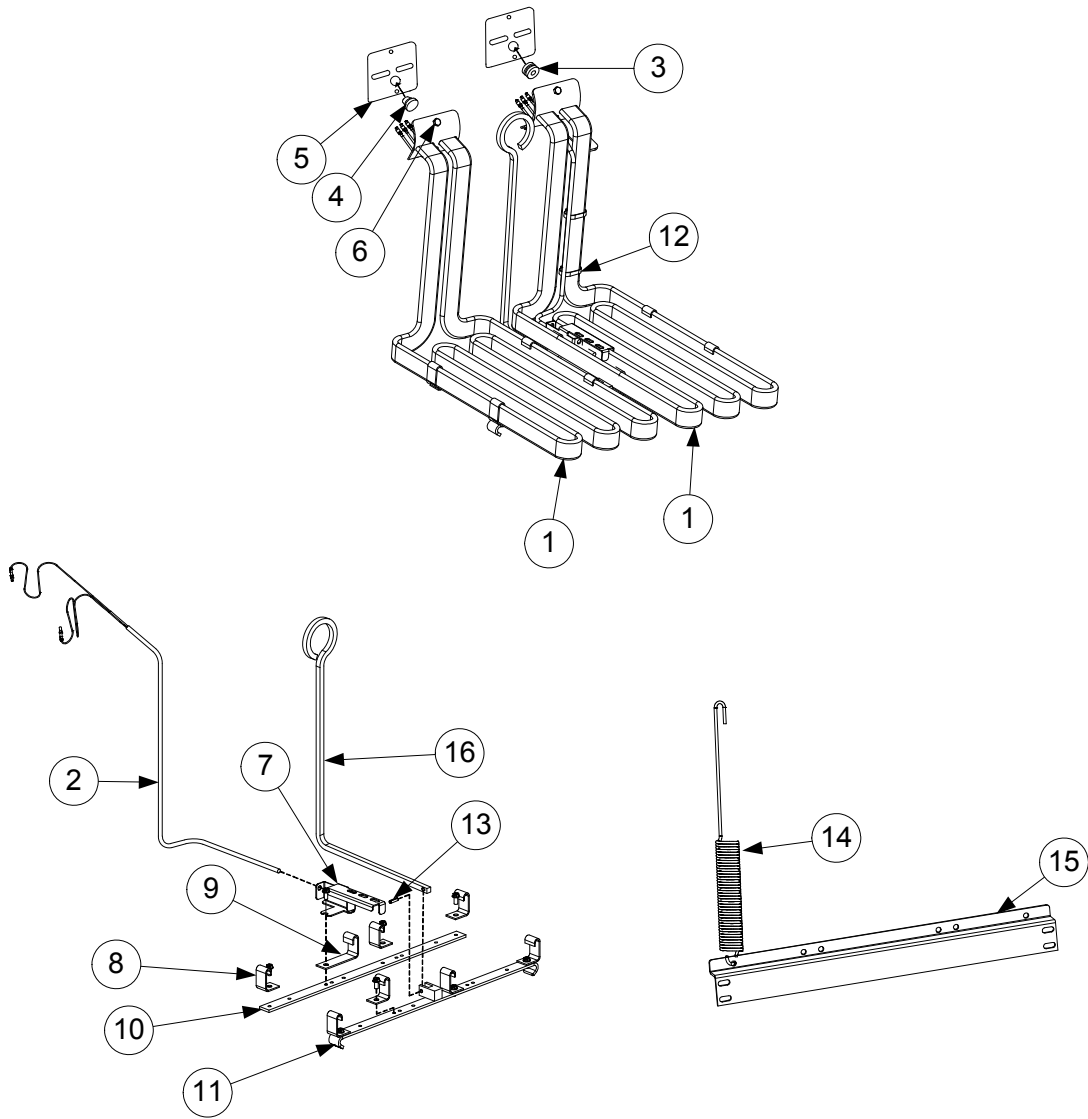

**NOTES:**

Items 14 and 15 are shown as associated parts. They are not part of either assembly.

**NOTE:** These elements apply only to the RE80/18 series fryers.

## 2.6.1 Heating Element Assemblies and Associated Parts (cont.)

ITEM	PART #	COMPONENT
1		<b>Element Assemblies</b>
	106-9757	208V, 17kW
	106-9974	208V, 21kW
	108-2702	230V, 17kW
	108-2703	230V, 21kW
	106-9961	240V, 17kW
	106-9963	240V, 21kW
	106-9962	480V, 17kW
	106-9964	480V, 21kW
		<b>Elements</b>
	826-2929	Element, 208V/8.5kW (for 17kW)
	826-2930	Element, 208V/10.25kW (for 21kW)
	826-2935	Element, 230V/8.5kW (for 17kW)
	826-2936	Element, 230V/10.25kW (for 21kW)
	826-2931	Element, 240V/8.5kW (for 17kW)
	826-2932	Element, 240V/10.25kW (for 21kW)
	826-2933	Element, 480V/8.5kW (for 17kW)
	826-2934	Element, 480V/10.25kW (for 21kW)
*	812-1794	Element Sleeving
2		<b>Temperature Probe</b>
	826-2928	Standard Temp Probe Kit. Includes ty-wrap and grommet.
	108-0790	FAST Temp Probe
	809-0567	Ty-wrap
3	816-0681	Grommet, Probe
4	816-0480	Plug, .375-inch Dome
5	816-0688	Gasket, Element
6	809-1003	Screw, 10-32 X 3/8-inch Hex Head SS
7	230-5041	Bracket, Temperature Probe
8	910-2042	Clamp, Element (Short)
9	230-0781	Clamp, Element (Long)
10	230-4902	Support, Full-Vat Element Rear
11	823-6937	Support, Full-Vat Element Front
12	809-0567	Ty-Wrap, Metal
13	810-1212	Pin, .125 X .5-inch Split
14	810-3030	Spring, Element Lift Left
*	810-3031	Spring, Element Lift Right
15	220-4860	Bracket, Lower Spring
16	810-2189	Handle, Element Lift
*	108-0317	Tilt Switch Assembly

\* Not illustrated.

## 2.6.2 Element Tube Assemblies

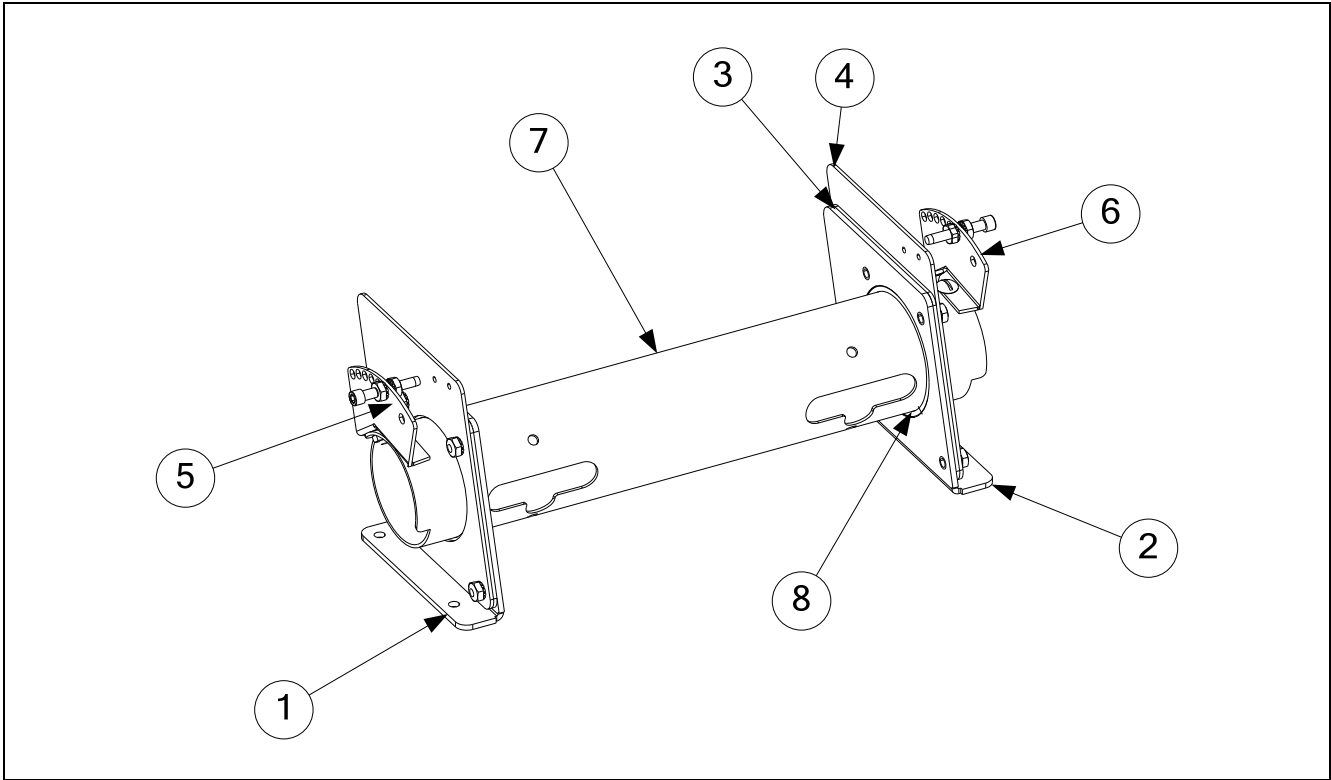

ITEM	PART #	COMPONENT
	106-7653SP	<b>Tube Assembly RE Element, Full-Vat</b>
1	108-0315	Bracket Assembly, LH Element Tube Support
2	108-0316	Bracket Assembly, RH Element Tube Support
3	220-0122	Plate, Element Tube Support Inner
4	220-0123	Plate, Element Tube Support Outer
5	106-7651	Bracket Assembly, LH Upper Spring
6	106-7652	Bracket Assembly, RH Upper Spring
7	810-2992	Tube, FV Element Mounting
8	810-2993	Bushing, Tube End Teflon
*	809-0766	Nut, 10-32 Hex HD SS
*	108-0317	Switch, Tilt Assy
*	807-4742	Switch, Tilt High Temp Long Lever Micro

\* Not illustrated.

## 2.7 Frypot Assemblies and Associated Parts

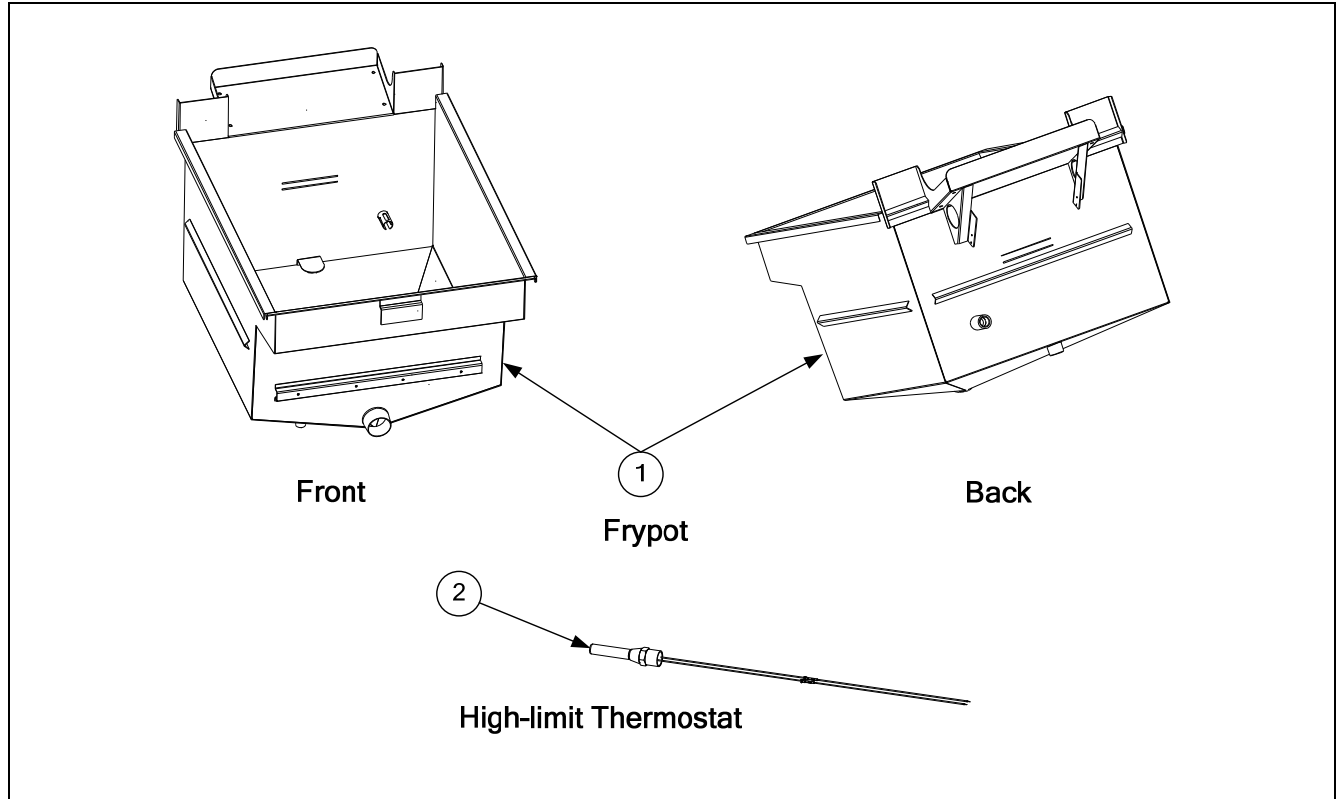

ITEM	PART #	COMPONENT
1		<b>Frypot Assembly</b>
	823-6935SP	Frypot, Non-filter
	823-6721SP	Frypot, Filter
	823-6936SP	Frypot, Church's/Popeye's
	823-8423SP	Frypot, KFC India
2	826-2456	Thermostat Assembly, High-Limit (Use 826-2455 for CE)
*	816-0785	Side Insulation
*	816-0786	Center Insulation
*	221-7274	Heat Shield, Left
*	222-7274	Heat Shield, Right
*		Topcap Heat Shield
*	220-5464	x1
*	220-5460	x2, x4 (2), x5 (1)
*	220-5461	x3, x5 (1), x6 (2)
*	823-7109	Splash Guard, Standard
*	823-7169	Splash Guard, Church's/Popeye's
*	108-0213	Float Switch

\* Not illustrated.

## 2.8 Controllers

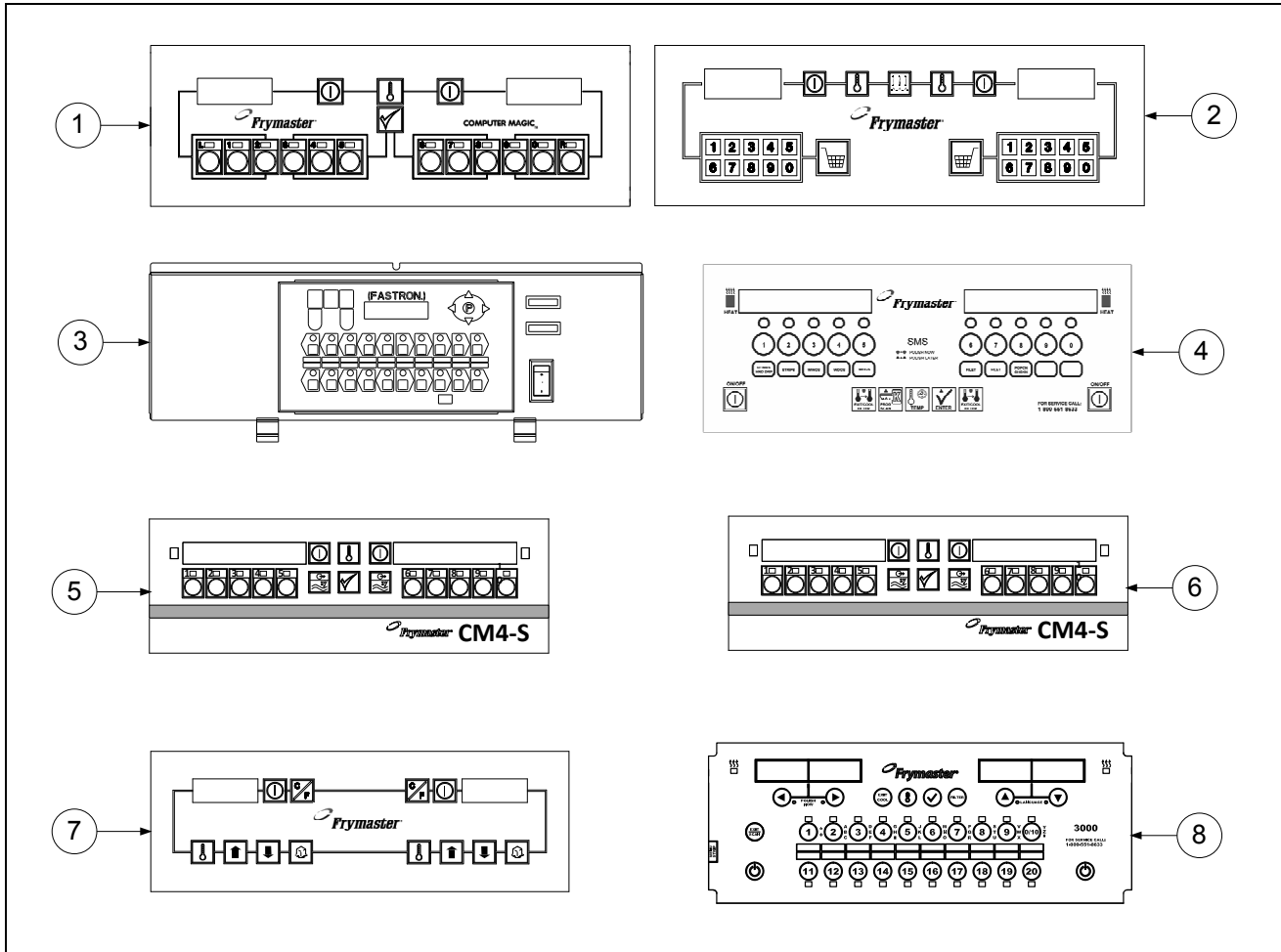

ITEM	PART #	COMPONENT
<b>Computers</b>		
1	826-2429	Computer Magic III.5, Full-Vat, non-CE
*	826-2399	Computer Magic III.5, Full-vat, CE
2	826-2401	Basket Lift Timer
3	108-0267	FAST Computer
4	106-4070	KFC-1 Computer
5	108-2297	Church's CM4S Computer
6	108-2296	Popeye's CM4S Computer
7	826-2329	Digital Controller, Full-Vat
8	826-2762	K3000 (Use 807-5354 for Menu Strip)
*	108-3114SP	F3000
*		<b>K3000 Locator Harness</b>
	108-0485SP	Position 1 (Fryer 1 position (Far left fryer position))
	108-0486SP	Position 2 (Fryer 2 position from left to right)
	108-0487SP	Position 3 (Fryer 3 position from left to right)
	108-0488SP	Position 4 (Fryer 4 position from left to right)
	108-0489SP	Position 5 (Fryer 5 position from left to right)
*	802-2021	Graphic Sheet of Symbols

\* Not illustrated.



## 2.9 Electronics and Wiring Components

### 2.9.1 Component Boxes

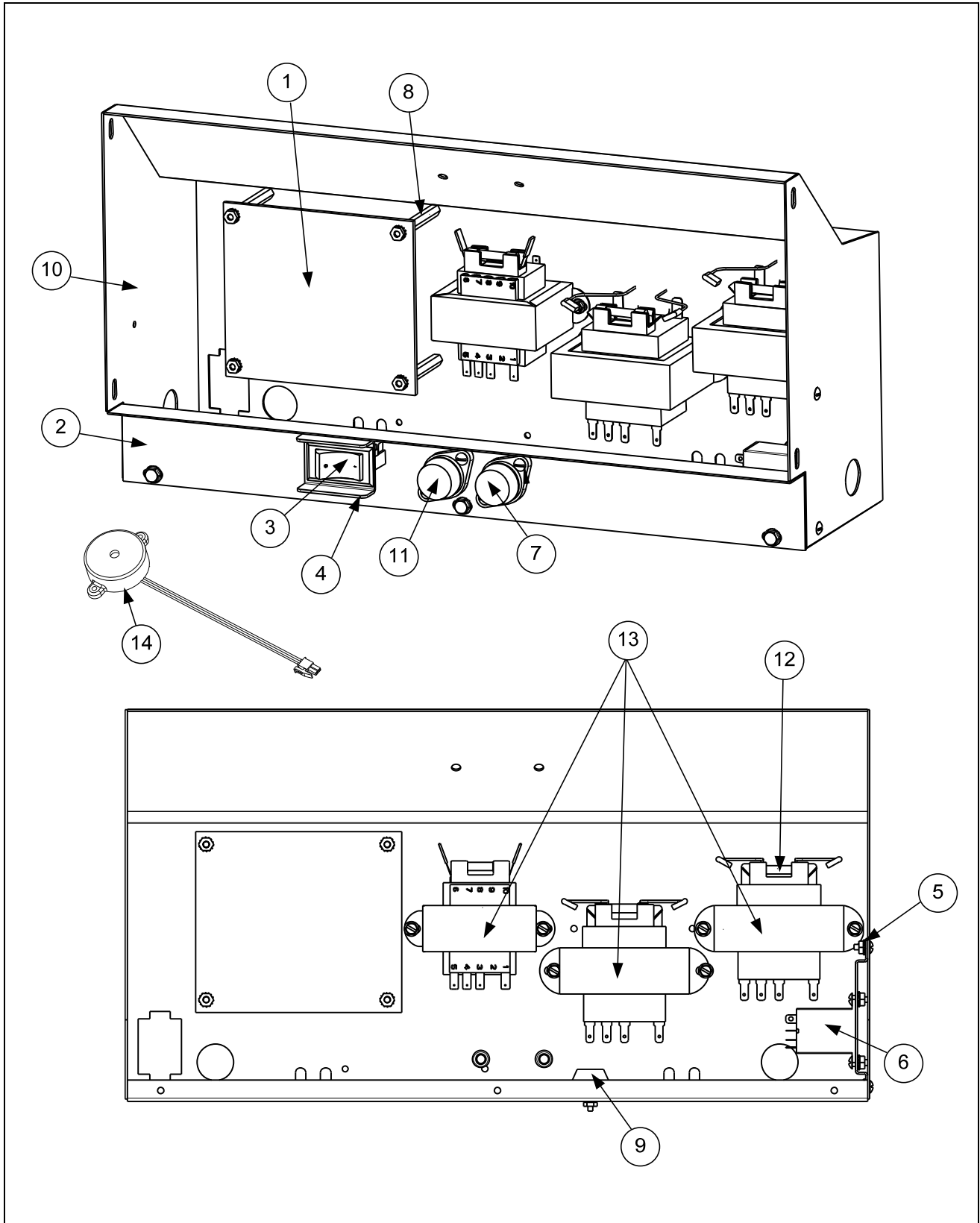

## 2.9.1 Component Boxes

ITEM	PART #	COMPONENT
		<b>Component Box Assemblies (for reference)</b>
	106-9730	208/240V, Filter
	106-9732	208/240V, Non-filter
	108-0279	220/230/240/250/415/400/430V, Filter
	108-0278	220/230/240/250/415/400/415/430V, Non-filter
	108-4357	240/415 KFC India, Filter
	108-0420	480V, Filter
	108-0421	480V, Non-filter
	108-0330	480V, no switch, no basket lift
		<b>Component Box Parts</b>
1	826-2260	Interface Board ( <i>For use with Frymaster controller ONLY</i> ).
	826-2262	Interface Board ( <i>For use with FAST controller ONLY</i> ).
*	106-9930	Harness, Filter
*	106-9965	Harness, Non-filter
2	220-4465	Panel, Switch
3	230-4346	Guard, Switch
4	807-4036	Switch
5	220-5805	Standoff, Relay, Filter
6	807-4114	Relay, 24VAC Coil, Filter
7	807-0922	Holder, Screw-Type Buss Fuse
*	807-4765	Harness, Control
8	809-0963	Standoff, 6-32, 1/4" x 2.00 NP
9	810-1164	Block, Screwless Terminal
10	823-6745	Box, Component
11	807-2278	Fuse, 20 Amp
12	807-1597	Fuse, 3 Amp Slo-blo, Filter (220-250V)
13		<b>Transformers</b>
	807-0979	208/240V, 12V
	807-0680	208/240V
	807-2180	208/240V, 24V, 50VA
	807-2191	V&F, 208/230/240V, 12V
	807-0800	120V, 50/60 Hz-24V, 50VA
	807-0855	120V, 50/60 Hz-12V, 20VA
	807-3892	440/480V to 12/24V
14	810-3141	Sound Device, SMT Standard and KFC FAST
*	108-0273	Speaker, KFC (KFC-1, K3000 and F3000)

\* Not illustrated.

## 2.9.2 Contactor Boxes

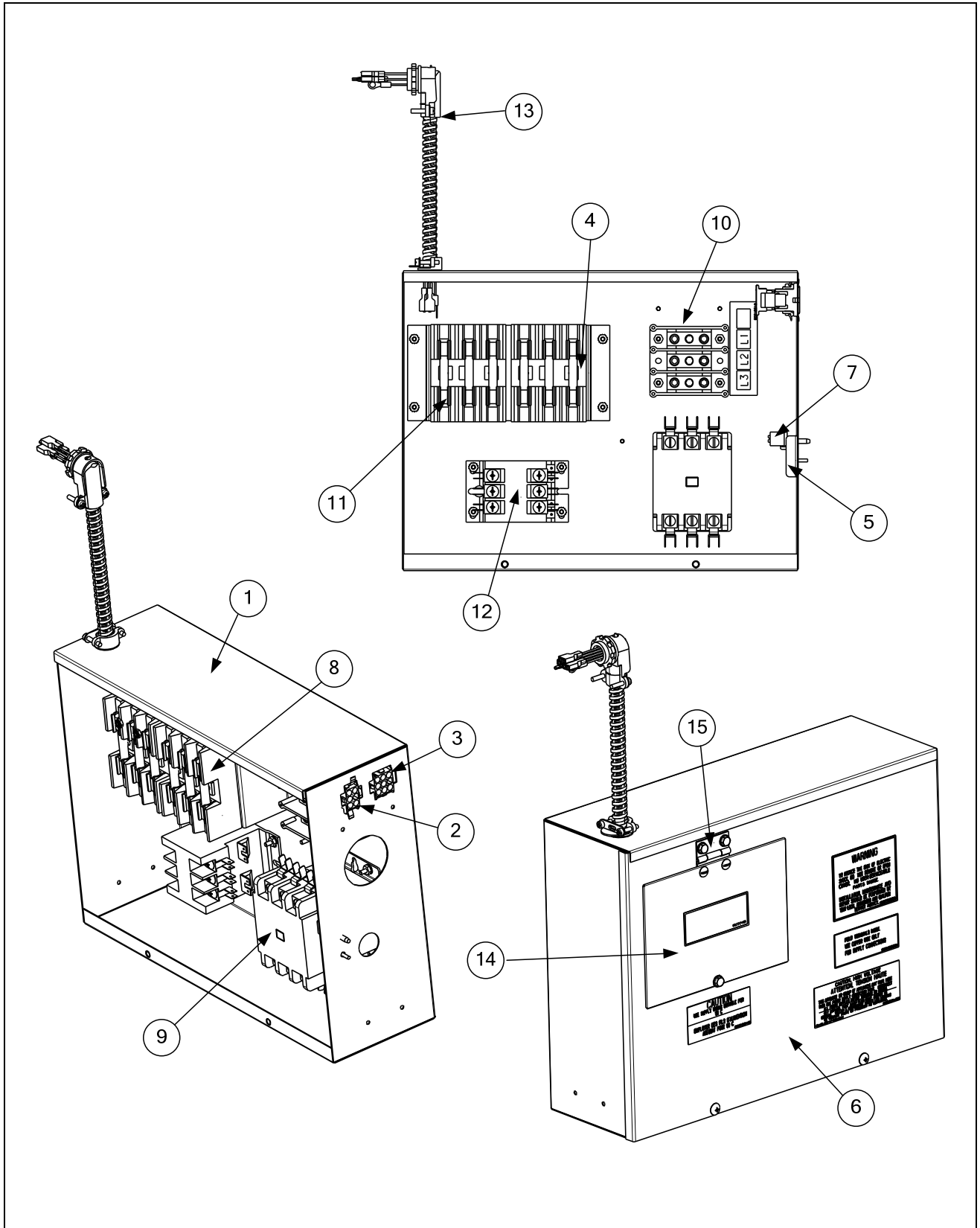

**NOTES:** Left and right contactor box assemblies are mirror images of one another. With the exception of the box itself, most components of a left-hand assembly are the same as those in the corresponding right-hand assembly and vice versa. The configuration illustrated shows most possible components, but a particular configuration may not have all the components shown.

ITEM	PART #	COMPONENT
		<b>Contactor Box Assemblies (for reference only)</b>
	106-9967	17 kW, 3-wire 208/240V and 21kW/480V, Left
	106-9966	17 kW, 3-wire 208/240V and 21kW/480V, Right
	108-3522	21kW, 3-wire 208/240 only, Left
	108-3523	21kW, 3-wire, 208/240 only, Right
	108-0427	17 kW, 4-wire, 208/240V and 21kW/480V, Left
	108-0426	17 kW, 4-wire, 208/240V and 21kW/480V, Right, Std and India KFC
	108-4358	17 kW, 4-wire, 208/240V and 21kW/480V, Left India KFC
	108-4800	17 kW, 4-wire, 220/380 only, Left – Export China Only
	108-4799	17 kW, 4-wire, 220/380 only, Right – Export China Only
	108-0037	21kW, 4-wire 208/240 only
	108-1861	17kW, Single, 208/240 only
	108-3521	21kW, Single, 208/240 only
	108-3526	21kW, 4-wire, Single, Export PBI
		<b>Contactor Box Parts</b>
1	106-9601	Stud Assembly, Left Contactor Box
*	106-9600	Stud Assembly, Right Contactor Box
2	106-9735	Harness, 6-pin
*	108-2439	Harness, 6-pin, PBI
3	106-9736	Harness, 9-pin
*	108-2440	Harness, 9-pin, PBI
4	200-6648	Bracket, Fuse Block
5	200-6809	Bracket, Ground Lug Holder
6	221-5553	Cover, 21kw Contactor Box
*	220-5103	Cover, 17kw Contactor Box
7	807-0070	Terminal Lug
8	807-0501	Fuse Block
9	807-2283	Contactor, 63 AMP, Mechanical, 24V Coil (21kW)
*	807-2284	Contactor, 50 AMP, Mechanical, 24V Coil (17kW)
*	810-1202	Contactor, 40 AMP, Mechanical, 24V Coil (17kW)
10	807-3610	Terminal Block
*	807-1268	Terminal Block, Splicer Single Pole (4-wire)
11	807-4017	Fuse, 50 AMP, 300 VDC
12	810-1202	Contactor, 40 AMP, 24V Coil (17kW)
*	807-2284	Contactor, 50 AMP, Mechanical, 24V Coil (17kW)
13	108-1786	Harness, Contactor Box
14	220-6545	Door, Fuse Access
15	810-0519	Hinge, Fuse Access
*	220-5484	Mount, Contactor Box (2 per box)

\* Not illustrated.

### 2.9.3 Fuse Boxes

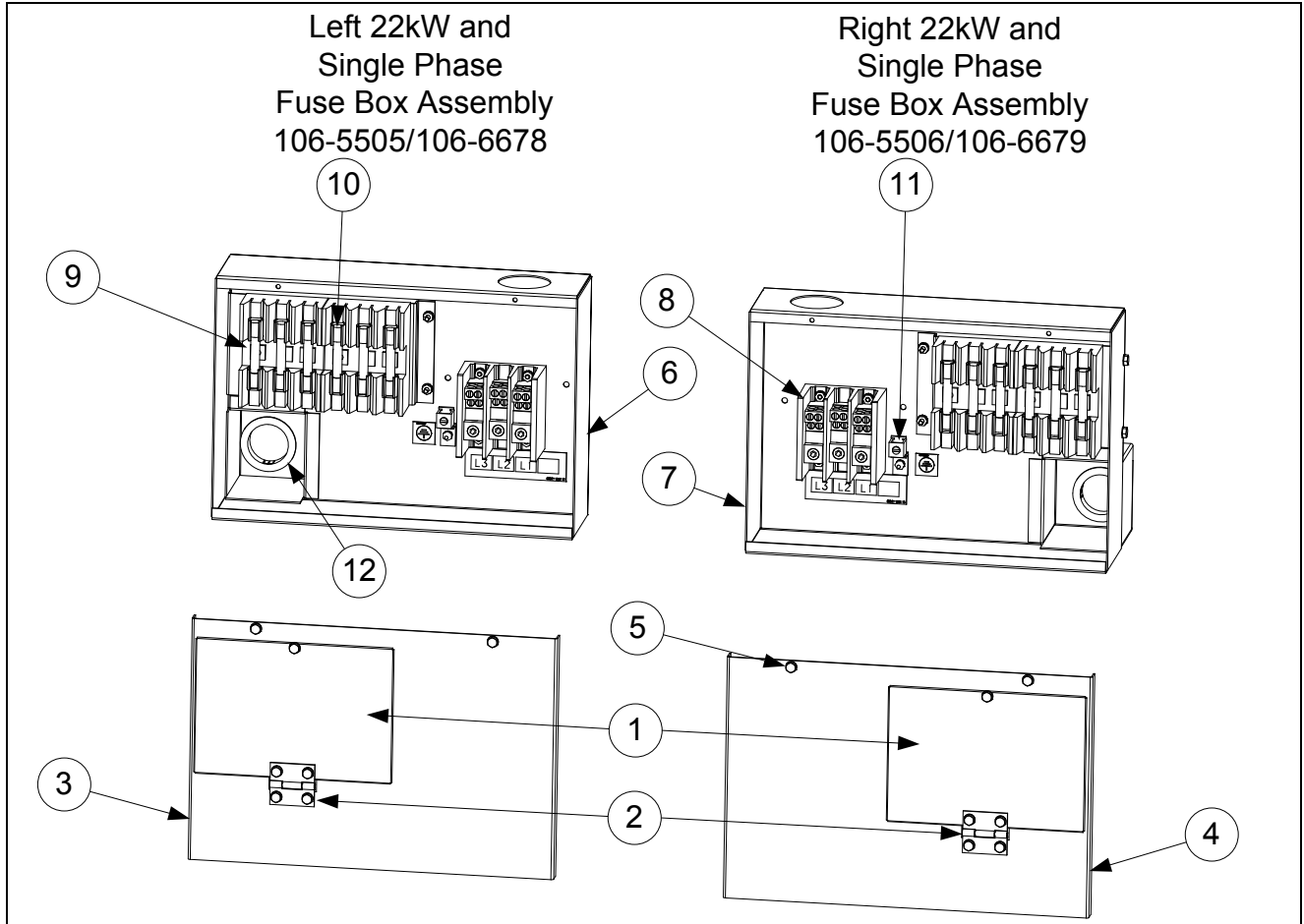

ITEM	PART #	COMPONENT
1	200-2334	Door
2	810-0519	Hinge
3	221-0523	Cover, LH Fuse Box
4	222-0523	Cover, RH Fuse Box <i>(Used on Single Station Fryers also)</i>
5	809-0434	Nut, RH Fuse Holder
6	823-5585	Box, LH Fuse
7	823-5557	Box, RH Fuse
	823-5797	Box, Single Station Fryer Only
8	807-3970	Block, 3 Pole 600V 175A Terminal
9	807-0501	Fuse Block, Buss #2968 3-Pole
10	807-2240	Fuse, 60 AMP 300VAC
11	807-0070	Terminal, Ground Lug
12	807-0128	Bushing, Insulating Heyco

## 2.9.4 Terminal Blocks

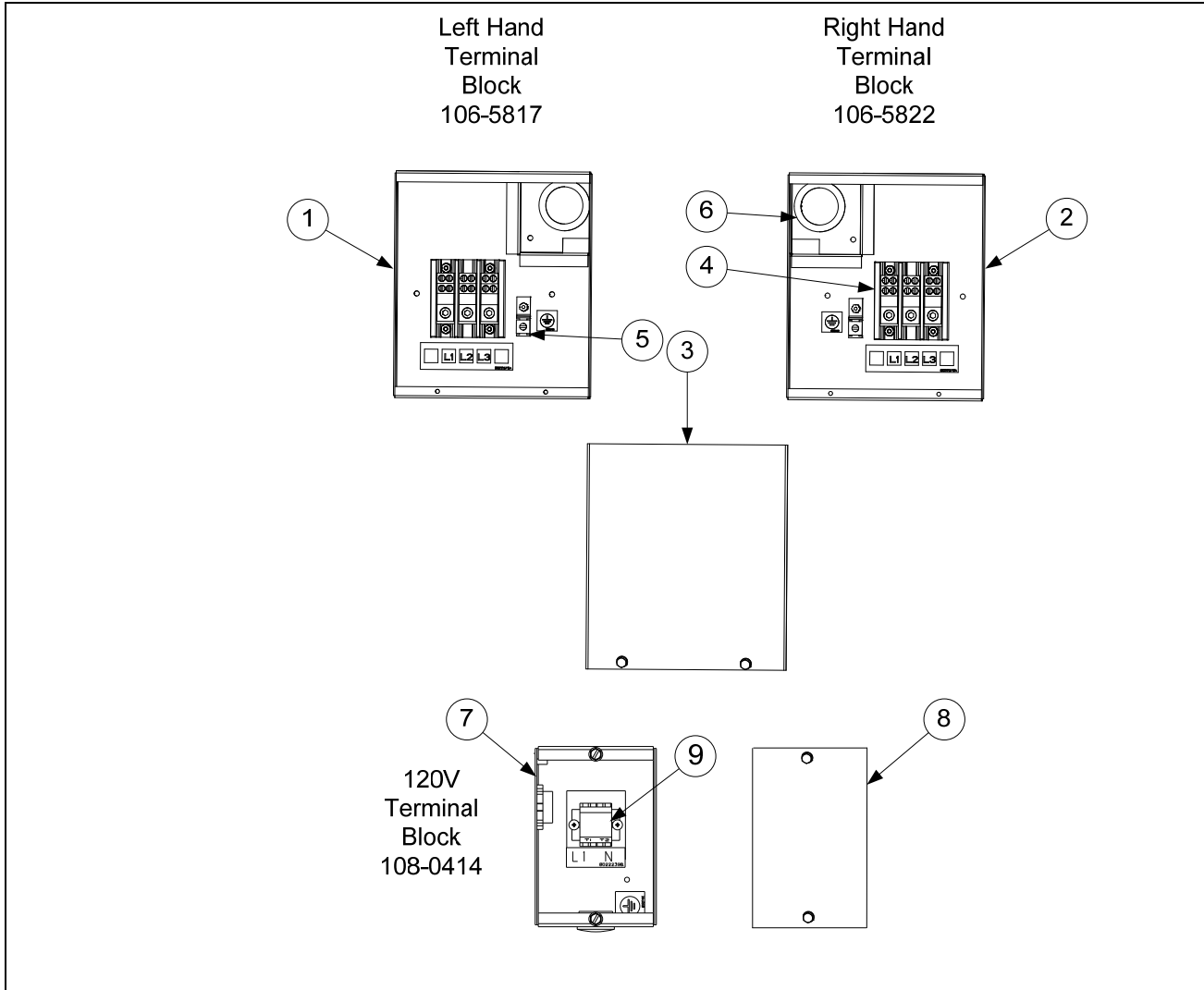

ITEM	PART #	COMPONENT
1	823-5631	Box, LH Rear Terminal Block
2	823-5632	Box, RH Rear Terminal Block
	823-5797	Box, Single Station Fryer Only ( <i>see previous page for cover 222-0523</i> )
3	220-0801	Cover, Rear Terminal Block Box
4	807-3970	Block, 3 Pole 600V 175A
5	807-0070	Terminal, Ground Lug
6	807-0128	Bushing, Insulating Heyco
7	824-1378	Box, 120V Power Cord
8	200-8030	Cover, 120V Power Cod Box
9	810-1164	Block, 1 Piece Screw less Terminal
*	108-5442	Box, Church's Cord Connect

\* Not illustrated.

## 2.9.5 Cordsets

ITEM	PART #	COMPONENT
*	807-4658	Domestic 208/240V
*	807-3834	Domestic 480V, Export Non-CE 208/240V
*	807-3981	Export, Generic 220/250V, KFC Export India, CE Export

\* Not illustrated.

## 2.10 Wiring

### 2.10.1 Contactor Box Wiring Assemblies

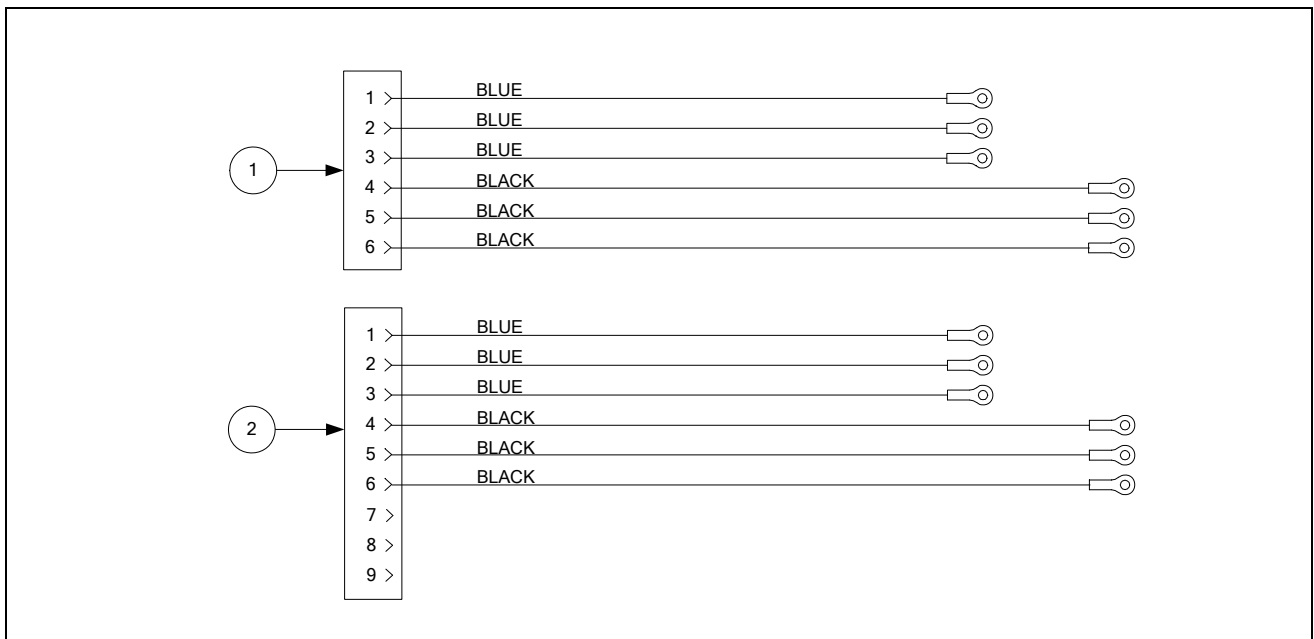

ITEM	PART #	COMPONENT
1	106-9735	6-pin
	106-9736	9-pin

## 2.10.2 Component Box, Filter Pump and Basket Lift Wiring Harnesses

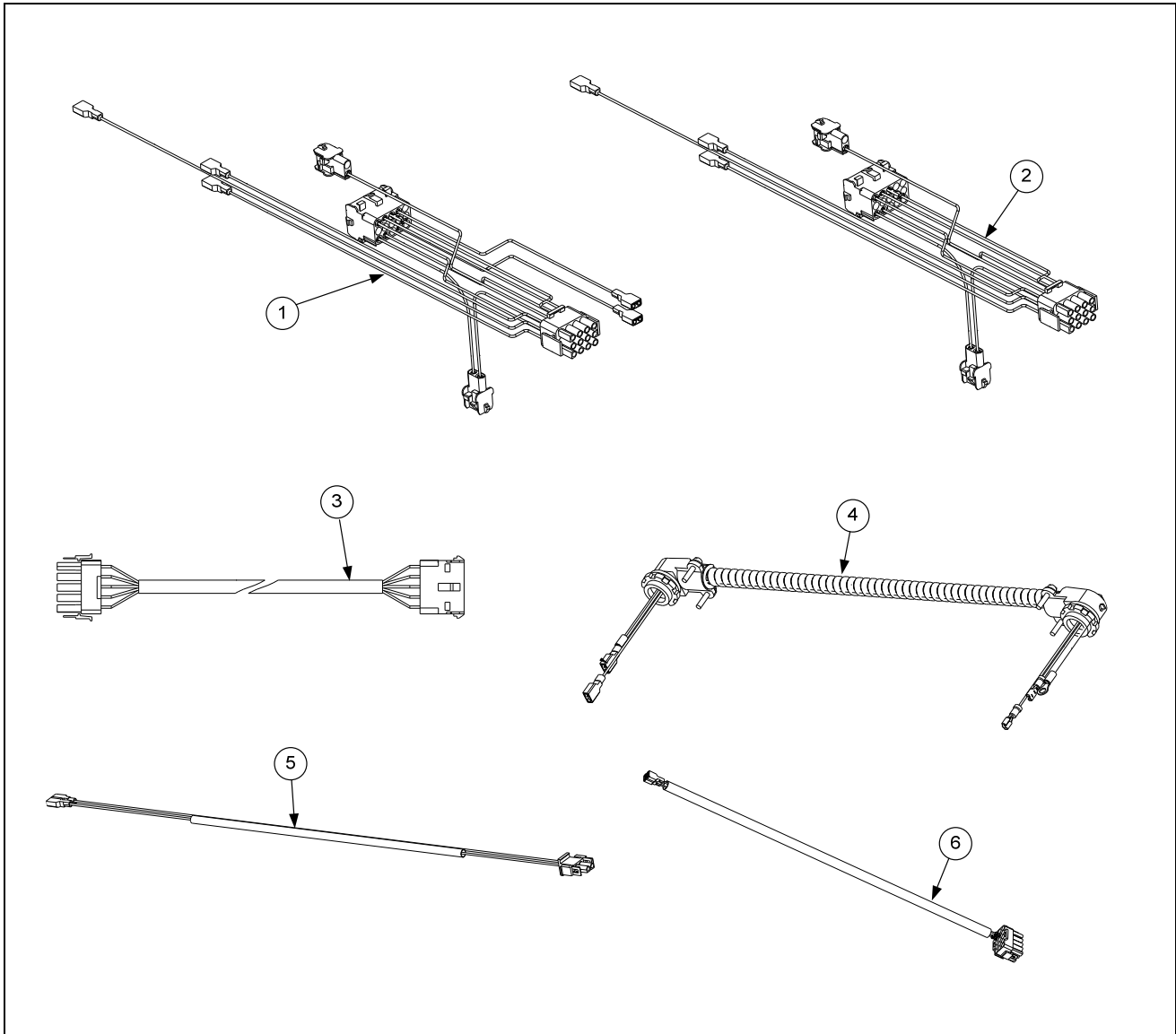

ITEM	PART #	COMPONENT
1	106-9930	Component Box Harness, Filter
2	106-9965	Component Box Harness, Non-filter
3	807-4765	Component Box Harness, Control
4	106-9918	Filter Pump Harness
5	106-9924	Drain Safety Harness
*	108-0255	Drain Safety Harness, KFC-1, CM4S, Popeye's and Church's
*	807-5159	Drain Safety Harness, K3000
*	106-7718	Drain Jumper Harness
6	106-9928	Oil Return Harness, Rear

\* Not illustrated.



## 2.11 Wiring Connectors and Pin Connectors

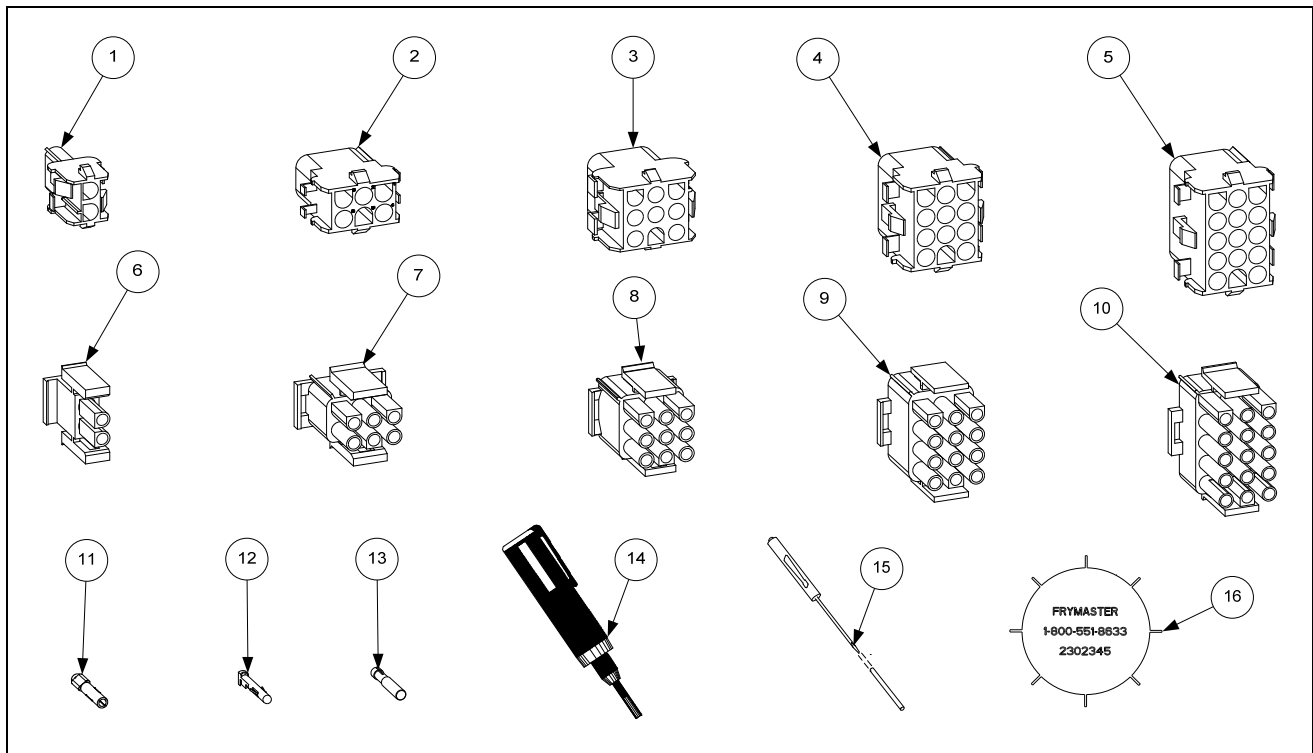

ITEM	PART #	COMPONENT
1	807-1068	2-Pin Female
2	807-0158	6-Pin Female
3	807-0156	9-Pin Female
4	807-0159	12-Pin Female
5	807-0875	15-Pin Female
6	807-1067	2-Pin Male
7	807-0157	6-Pin Male
8	807-0155	9-Pin Male
9	807-0160	12-Pin Male
10	807-0804	15-Pin Male
11	826-1341	Terminal, Female Split Pin (pkg. of 25)
12	826-1342	Terminal, Male Split Pin (pkg. of 25)
13	807-2518	Plug, Mate-N-Lock (Dummy Pin)
14	807-0928	Extract Tool Pin Pusher
15	806-4855	Pin Pusher Screwdriver Assembly
16	230-2345	SMT Pin Extractor
*	807-4660PK	SMT Pin Service Repair Kit

\* Not illustrated.

## 2.12 Fasteners

ITEM	PART #	COMPONENT
*	809-0429	Bolt, ¼-inch – 20 x 2.00-inch Hex Head ZP Tap
*	809-0514	Capscrew, 5/16-inch-18 NC Hex
*	809-0448	Clip, Tinnerman
*	826-1366	Nut, 4-40 Keps Hex (Pkg. of 25) (809-0237)
*	826-1358	Nut, 6-32 Keps Hex (Pkg. of 25) (809-0049)
*	809-0247	Nut, 8-32 Keps Hex
*	826-1376	Nut, 10-32 Keps Hex (Pkg. of 10) (809-0256)
*	809-0766	Nut, 10-32 Keps Hex SS
*	809-0581	Nut, ½ NPT Locking
*	809-0020	Nut Cap 10-24 NP
*	826-1372	Nut Grip ¼-inch 1/4-20 Hex NP (Pkg. of 10) (809-0059)
*	809-0417	Nut Flange ¼-inch 1/4-20 Serr
*	809-0535	Nut, "T" ¼-inch-20 x 7/16 SS
*	809-0540	Nut, Lock ½-inch-13 Hex 2-Way ZP
*	826-1359	Screw, 4-40 x ¾-inch Slotted Round Head (Pkg. of 25) (809-0354)
*	826-1365	Screw, 6-32 x ⅜-inch Slot Head (Pkg. of 25) (809-0095)
*	809-0357	Screw, 6 x ⅜-inch Phillips Head NP
*	809-0359	Screw, 8 x ¼-inch Hex Washer Head
*	809-0360	Screw, 8 x ⅜-inch Hex Washer Slot Head
*	826-1371	Screw, 8 x ½-inch Hex Head ZP (Pkg. of 25) (809-0361)
*	809-0364	Screw, 8 x ⅝-inch Hex Washer Head ZP
*	809-0518	Screw, 8-32 x ⅜-inch Hex Washer Slotted Head SS
*	809-0104	Screw, 8-32 x ½-inch Slotted Head ZP
*	826-1363	Screw, 8-32 x ½-inch NP (Pkg. of 25) (809-0103)
*	826-1360	Screw, 10-24 x 5/16-inch Round Slot Head ZP (Pkg. of 25) (809-0024)
*	826-1330	Screw, 10-32 x ⅜-inch Slot Head SS (809-0117)
*	809-1003	Screw, 10-32 x ⅜-inch Hex Trim Head SS
*	826-1375	Screw, 10-32 x ¾-inch Hex Trim Head SS (Pkg. of 5) (809-0401)
*	809-1000	Screw, 10-32 x 1¼-inch Hex Sck C/S
*	826-1374	Screw, 10 x ½-inch Hex Head (Pkg. of 25) (809-0412)
*	809-0266	Screw, 10 x ½-inch Phillips Head ZP
*	809-0434	Screw, 10 x ⅜-inch Hex Washer Head NP
*	809-0123	Screw, 10 x ¾-inch Slot Head
*	826-1389	Screw, 1/4-20 x ¾-inch Hex Head ZP (Pkg. of 10) (809-0131)
*	809-0582	Washer ½ NPT Locking
*	809-0184	Washer, #10 LK ZP
*	809-0190	Washer, .625 X .275 X 40 Flat SS
*	809-0191	Washer, Lock 1/4 Spring ZP
*	809-0193	Washer, Flat 1/4 Nylon
*	809-0194	Washer, Flat 5/16 ZP

\* Not illustrated.

**THIS PAGE INTENTIONALLY LEFT BLANK**



Frymaster, L.L.C., 8700 Line Avenue, Shreveport, Louisiana 71106

TEL 1-318-865-1711

PRINTED IN THE UNITED STATES

SERVICE HOTLINE  
1-800-551-8633

819-6666  
06/2019