

OPERATOR'S GUIDE



KJH-50 SERIES

**Kentucky
Fried
Chicken®**



Frymaster®

A **WELBILT** Company



The Frymaster Corporation, 8700 Line Avenue, Shreveport, Louisiana 71135-1000
318-865-1711 FAX 318-862-2394

Printed in U.S.A.

SERVICE HOTLINE
1-800-551-8633

819-5254 6/96



WARNING
IMPROPER INSTALLATION, ADJUSTMENT, ALTERATION, SERVICE OR MAINTENANCE CAN CAUSE PROPERTY DAMAGE, INJURY OR DEATH. READ THE INSTALLATION, OPERATING AND MAINTENANCE INSTRUCTIONS THOROUGHLY BEFORE INSTALLING OR SERVICING THIS EQUIPMENT.

WARNING
FOR YOUR SAFETY, DO NOT STORE OR USE GASOLINE OR OTHER FLAMMABLE VAPORS AND LIQUIDS IN VICINITY OF THIS OR ANY OTHER APPLIANCE.

POST IN PROMINENT LOCATION THE INSTRUCTIONS TO BE FOLLOWED IN THE EVENT THE USER SMELLS GAS. THIS INFORMATION CAN BE OBTAINED BY CONSULTING THE LOCAL GAS SUPPLIER.

THE EQUIPMENT IS TO BE INSTALLED TO COMPLY WITH THE BASIC PLUMBING CODE OF THE BUILDING OFFICIALS AND CODE ADMINISTRATORS INTERNATIONAL, INC. (BOCA) AND THE FOOD SERVICE SANITATION MANUAL OF THE FOOD AND DRUG ADMINISTRATION (FDA).

WARNING
THIS PRODUCT CONTAINS CHEMICALS KNOWN TO THE STATE OF CALIFORNIA TO CAUSE CANCER AND/OR BIRTH DEFECTS OR OTHER REPRODUCTIVE HARM.
¹Operation, ²installation and ³servicing of this product could expose you to airborne particles of glasswool fibers and/or carbon monoxide. Inhalation of airborne particles of glasswool fibers is known to the State of California to cause cancer. Inhalation of carbon monoxide is known to the State of California to cause birth defects or other reproductive harm.

NOTICE
The Commonwealth of Massachusetts requires any and all gas products to be installed by a licensed plumber or pipe fitter.

TABLE OF CONTENTS

SECTION I - KJH50 FRYER	PAGE NO.
1. PARTS ORDERING/SERVICE INFORMATION	1
2. IMPORTANT INFORMATION	1
3. INSTALLATION INSTRUCTIONS	2
4. OPERATING INSTRUCTIONS	4
5. VENTILATION AND CLEARANCE	5
6. DRAINING AND FILTERING INSTRUCTIONS	6
7. KFMIII COMPUTER FUNCTION IDENTIFICATION	7
8. KFMIII COMPUTER OPERATING INSTRUCTIONS	8
9. KFMIII COMPUTER PROGRAMMING INSTRUCTIONS	9
10. ACCESSORIES	10
11. TROUBLESHOOTING GUIDE	12
12. SERVICE PROCEDURES	14
13. PREVENTIVE MAINTENANCE	16
14. FILTRATION	17
15. FILTER SYSTEM TROUBLESHOOTING	21

1. PARTS ORDERING/SERVICE INFORMATION

Parts orders must be placed directly with your local Frymaster Parts Distributor. A list of Frymaster Parts Distributors was included with the fryers when shipped from the factory. If you do not have access to this list, please contact the Service Department at Frymaster 1-800-551-8633 or 1-318-865-1711.

To help speed up your order, the following information is required.

Model Number: _____

Serial Number: _____

Type of Gas or Voltage: _____

Part Number: _____

Quantity Required: _____

Service information may be obtained by calling your local Factory Authorized Service Agency. A list of these agencies was packed with your fryer. Service information may also be obtained by calling the Frymaster Service Department. When calling, please have the following information available:

Model Number: _____

Serial Number: _____

Type of Gas or Voltage: _____

Nature of service problem: _____

Any other information that may be helpful in solving your service problem.

PARTS ORDERING/SERVICE INFORMATION
CANADA — Garland Commercial Ranges, Ltd.,
1177 Kamato Road, Mississauga, Ontario L4W 1X4.

NOTE: RETAIN AND STORE THIS MANUAL IN A SAFE PLACE FOR FUTURE USE. ADDITIONAL COPIES MAY BE OBTAINED FROM YOUR AUTHORIZED SERVICE AGENCY.

2. IMPORTANT INFORMATION

INTRODUCTION

The KJH-50 Series are deep-well, open-pot fryers designed for cooking fried products. These models are available in full or split-pot arrangements manufactured to operate on the type gas specified by the user: i.e., natural, propane, or manufactured gas. The instructions contained in this manual should be read thoroughly before attempting to operate these fryers.

This equipment is made in America and has American sizes of hardware. All hardware metric conversions are approximate and can vary in size.

OPERATING, INSTALLATION, AND SERVICE PERSONNEL

Operating information for FRYMASTER equipment has been prepared for use by qualified and/or authorized operating personnel.

All installation and service on FRYMASTER equipment must be performed by qualified, certified, licensed, and/or authorized installation or service personnel.

DEFINITIONS

QUALIFIED AND/OR AUTHORIZED OPERATING PERSONNEL

Qualified or authorized operating personnel are those who have carefully read the information in this manual and have familiarized themselves with the equipment functions or have had previous experience with the operation of equipment covered in this manual.

QUALIFIED INSTALLATION PERSONNEL

Qualified installation personnel are: individuals, a firm, corporation, or a company which either in person or through a representative are engaged in, and are responsible for the installation of gas-fired appliances. Qualified installation personnel must be experienced in such work, be familiar with all gas precautions required, and have complied with all requirements of state and local codes.

QUALIFIED SERVICE PERSONNEL

Qualified service personnel are those familiar with FRYMASTER equipment and have been authorized by THE FRYMASTER CORPORATION. All authorized service personnel are required to be equipped with a complete set of service parts manuals and stock a minimum amount of parts for FRYMASTER equipment.

A list of Frymaster Factory Authorized Service Centers was included with the fryer when shipped from the factory. If you do not have access to this list, please contact the Frymaster Customer Service Department, using the number listed on the front of this manual. Failure to use qualified service personnel will void the Frymaster warranty.

SHIPPING DAMAGE CLAIM PROCEDURE

For your protection, please note that the FRYMASTER equipment was carefully inspected and packed by skilled personnel before leaving the factory. The transportation company assumes full responsibility for safe delivery upon acceptance of the equipment.

What to do if equipment arrives damaged:

1. FILE CLAIM FOR DAMAGES IMMEDIATELY — Regardless of extent of damage.
2. VISIBLE LOSS OR DAMAGE — Be sure this is noted on the freight bill or express receipt and is signed by the person making the delivery.
3. CONCEALED LOSS OR DAMAGE — If damage is unnoticed until equipment is unpacked, notify freight company or carrier immediately, and file a "concealed damage" claim. This should be done within fifteen (15) days of date of delivery. Be sure to retain container for inspection.

FRYMASTER DOES NOT ASSUME RESPONSIBILITY FOR DAMAGE OR LOSS INCURRED IN TRANSIT.

3. INSTALLATION INSTRUCTIONS

PROPER INSTALLATION IS ESSENTIAL FOR TROUBLE-FREE OPERATION. ANY ALTERATIONS TO THE EQUIPMENT VOIDS THE FRYMASTER WARRANTY.

Before installing the newly arrived equipment, inspect the equipment carefully for visible and concealed damage. See "Shipping Damage Claim Procedure" this page.

The fryer installation area must allow for a 6-inch (15 cm) clearance at both sides and back adjacent to flammable materials. A minimum of 24-inches (61 cm) should be provided at the front of the fryer(s) for servicing and proper operation. Air for combustion enters the unit below the cabinet base. **DO NOT BLOCK THE AREA AROUND THE BASE OR UNDER THE FRYERS.**

THE APPLIANCE AREA MUST BE KEPT FREE AND CLEAR OF COMBUSTIBLES.

FRYERS EQUIPPED WITH CASTERS

1. Adequate means must be provided to limit the movement of the fryer(s) without depending on the gas connector and any quick-disconnect device or its associated piping. This can be accomplished by attaching restraining chains/cables to the outside of the front casters and securing the chains/cables to the floor.
2. Installation shall be made with a gas connector that complies with the Standard for Connectors for Movable Gas Appliances ANSI Z21.69-1987 and Addenda, Z21.69-1989, and a quick-disconnect device that complies with the Standard for Quick-Disconnect Devices for Use With Gas Fuel, ANSI Z21.41-1989.

NATIONAL CODE REQUIREMENTS

Frymaster gas fryers are manufactured to use the type gas specified on the rating plate located on the fryer door(s). When installing gas fryers in the UNITED STATES, the installation must conform with the latest edition of the National Fuel Gas Code, ANSI Z223.1. In addition, all local codes must be followed. In CANADA, installation must conform with Standard CAN/CGA-B149.1 or .2, "Installation Codes for Gas Burning Appliances & Equipment". Again, all local codes must be complied with.

When installing any type of gas-fired commercial kitchen equipment, Standard No. 96 and Standard 211 of the National Fire Protection Association must be followed implicitly. A copy of the standards may be obtained from the National Fire Protection Association, Battery March Park, Quincy, Massachusetts 02269.

In Australia, this appliance must be installed by an authorized person, in accordance with the manufacturer's instructions, local gas, and electrical regulations, and requirements of AA601, "Installation Requirements for Gas Burning Appliances".

ELECTRICAL GROUNDING INSTRUCTIONS

WARNING

All electrically operated appliances must be electrically grounded in accordance with local codes, or in the absence of local codes, with the latest edition of the National Electric Code, ANSI/NFPA No. 70, in CANADA, with CSA-C22-1 Canadian Electrical Code Part 1. In the U.S. and Canada, the electrical supply must be 120 VAC, 60 Hz. Check the electric rating plate and wiring diagram located on the inside of the fryer door. In other countries, check the electric rating plate on the inside of the fryer door.

This appliance is equipped with a three-prong 120 volt (230 V. Australia) grounding plug for your protection against shock hazard and must be plugged directly into a properly grounded three-prong

receptacle. DO NOT CUT OR REMOVE THE GROUNDING PRONG FROM THIS PLUG. This fryer requires electrical power for operation. Turn the gas control valve to the OFF position in case of prolonged power outage. This will prevent the chance of the fryer coming on when unattended. DO NOT ATTEMPT TO USE THE FRYER DURING POWER OUTAGE.

GAS CONNECTIONS AND PIPE SIZE

The size of the fryer gas supply pipe is very important. If the pipe is too small, the gas pressure at the burner manifold will be low. This will cause slow recovery and delayed ignition. The incoming gas supply line should be a minimum of 1-1/2". All single KJH-50 fryers require a 3/4" (19 mm) I.D. connection. Batteries of two and three KJH-50 fryers require a 1" connection. NOTE: Runs of more than 20 feet and more than 4 fittings for elbows require an increase of one pipe by one size. For LP gases, the next smaller pipe size may be used. If in doubt about pipe size, consult the local gas company.

Caution:

Before connecting the new pipe to the KJH-50 series fryers, the pipe MUST be blown out thoroughly to remove all foreign particles. Foreign particles in the burner and controls may cause improper and dangerous operation.

When using thread compound, use very small amounts on male threads only. Use a pipe thread compound that is not affected by the chemical action of LP gases (Loctite PST 56747). DO NOT apply compound to the first two threads. This will prevent clogging of the burner orifices and control valve.

Have the installer check all gas plumbing with a soap solution for leaks. DO NOT use matches, candles, or other ignition materials.

The fryers and individual shut-off valves must be disconnected from the gas supply piping system during any pressure testing of the gas supply piping at pressures equal to or greater than 1/2 psig. (3.45kPa) (13.84inW.C.)

The fryers must be isolated from the gas supply piping system by closing its individual manual shutoff valve during any pressure testing of the gas supply piping system at test pressures equal to or less than 1/2 psig (3.45 kPa).

WARNING

DO NOT ATTACH APRON DRAIN BOARD TO A SINGLE FRYER. THE FRYER MAY BECOME UNSTABLE, TIP OVER, AND CAUSE INJURY.

FOR FRYERS EQUIPPED WITH FRYMASTER COMPUTERS

This equipment generates and uses radio frequency energy. If it is not installed and used properly in accordance with the manufacturer's instructions, it

may cause interference to radio and television reception. It has been tested and found to comply with the limits of a Class A computing device in accordance with the specifications in Subpart J of Part 155 of FCC Rules, which are designed to provide reasonable protection against such interference in a residential installation. However, there is no guarantee that interference will not occur in a particular installation. If this equipment does cause interference to radio or television reception, the user is encouraged to correct the interference by one of the following procedures:

1. Reorient the receiving antenna of the receiver.
2. Relocate the computer with respect to the receiver.
3. Move the computer away from the receiver.
4. Plug the computer into a different outlet so that the computer and receiver are on different branch circuits.

If necessary, the user should consult the dealer or an experienced radio and television technician for additional suggestions.

The user may find the following booklet prepared by the Federal Communications Commission helpful: "How to Identify and Resolve Radio-TV Interference Problems". This booklet is available from the U. S. Government Printing Office, Washington, DC 20402, Stock No. 004-000-00345-4.

AFTER FRYER IS UNDER FRY STATION EXHAUST HOOD

CAUTION:

DO NOT CONNECT FRYER TO GAS SUPPLY BEFORE COMPLETING STEPS 1 THROUGH 4.

NOTE: Make sure fryer ON/OFF switches are turned Off before connecting fryer power cord.

1. Test exhaust hood electrical power system as follows:
 - a. Plug fryer electrical cord into any fry station electrical receptacle.
 - b. The fryer computer should display "OFF."
 - c. Press the fryer power switch to "ON" position.
 - d. NOTE that the computer displays "LO."
 - e. Press the fryer power switch to "OFF."
 - f. This completes the exhaust hood electrical power system test.
2. To level fryers equipped with legs, screw out the legs approximately one inch. Legs should be adjusted so that the fryer is level and at its proper height under the exhaust hood.

For fryers equipped with casters, there are no built-in leveling devices. The floor where the fryers are installed must be level.

3. Check the serial plate on the fryer door to determine if fryer burner is set up for the proper gas type before connecting the quick disconnect or piping from the building gas supply pipe.
 - a. Minimum incoming gas pressure for NATURAL GAS is 6.0 in. W.C.(1.49kPa). Maximum incoming gas pressure for NATURAL GAS is 14 in. W.C. (3.49kPa).
 - b. Minimum incoming gas pressure for LP GAS is 11 in. W.C. (2.74kPa). Maximum incoming gas pressure for LP GAS is 14 in. W.C. (3.49kPa).
4. Connect the quick disconnect hose or pipe from the building gas pipe to the fryer quick disconnect fitting under front of fryer or pipe at rear of fryer.
5. See FILLING WITH SHORTENING. Close the fryer drain valve and fill the frypot with cooking oil/shortening to the OIL LEVEL line (or the bottom level line for fryers equipped with 2 oil level lines) at back of frypot. Light the fryer. Refer to LIGHTING INSTRUCTIONS.
6. Test all piping for gas leaks. A soap solution should be used for this purpose. Never use a flame

WARNING IF GAS ODORS ARE DETECTED, THE FRYER GAS SUPPLY MUST BE SHUT OFF AT THE MAIN SHUT-OFF VALVE, AND THE LOCAL GAS COMPANY OR AUTHORIZED SERVICE AGENCY CONTACTED FOR SERVICE.

7. Burner operating gas pressure can be checked at this time. REFER TO CHECK BURNER MANIFOLD PRESSURE in Section 13 of this manual.
 - a. Burner manifold pressure NATURAL GAS MUST BE 3.5 in W.C. (0.75kPa).
 - b. Burner manifold pressure LP GAS must be 8.25 in W.C. (2.0kPa).

NOTE: This should be checked by the local gas company or authorized service agent.

8. The burner combustion air was preset at the factory; however, make-up air and vent hood exhaust fans could cause this setting to change. This setting may have to be readjusted after the KJH-50 Series fryers have been installed. REFER TO PREVENTIVE MAINTENANCE in Section 13 of this manual.
9. Check the computer programmed temperature.

4. OPERATING INSTRUCTIONS

WARNING

When fryers are in use, fryer restraint chains/cables must be installed in order to prevent the fryer from tipping and splashing hot liquid.

FILLING WITH SHORTENING

Cooking oil/shortening capacity of the KJH-50 Series fryers is 50 lbs. (25 litres) for a full pot and 25 lbs. (12.47 litres) for each half of a split frypot (room temperature cooking oil/shortening, 70°F/21°C).

1. Make sure fryer switch is OFF.
2. Close frypot drain valve, remove basket support rack if required.
3. Fill empty frypot to the OIL LEVEL line or the bottom line for frypots equipped with 2 oil level lines. When solid shortening is used, it must be thoroughly packed down into the frypot cold zone.

LIGHTING INSTRUCTIONS — KJH-50 SERIES FRYER

Frypot MUST be filled before lighting. See FILLING WITH SHORTENING.

1. Press fryer power ON/OFF switch to OFF position.
2. Turn gas valve knob (located behind fryer door) to OFF position. See Figure 1.
3. Turn gas valve knob (located behind fryer door) to ON position. See Figure 2.
4. Turn fryer on by pressing ON/OFF Switch to "ON"; one of the following will be displayed:
 - a. The "Heating" light will cycle on and off indicating the burner is operating in the melt cycle mode. Display will read "LO" until shortening reaches temperature of 255°F.
 - b. At 255°F and above, actual shortening temperature will be displayed until the temperature is in the cooking range.
 - c. When the shortening temperature reaches the cooking range, the computer will display "drop" and is ready for the cooking cycle to begin.

ACCESSING FRYERS FOR SERVICING

WARNING

Moving a fryer filled with hot shortening may cause splattering of the hot shortening. Extreme care must be exercised. It is recommended that the operator or servicer follow the draining instructions on Page 6 of this manual before attempting to relocate the fryer.

1. Disconnect quick-disconnect hose and power cord
2. Remove restraining devices.
3. Relocate fryer so that access can be obtained to perform necessary maintenance.
4. After servicing has been completed, reconnect quick-disconnect hose and power cord; and attach restraining devices.

SHUTTING FRYER(S) OFF FOR SHORT PERIODS

1. Press fryer power switch to OFF position.
2. Put frypot cover(s) in place.

SHUTTING FRYER(S) OFF WHEN CLOSING STORE

1. Press fryer power switch to OFF position.
2. Turn gas valve knob clockwise to OFF.
3. Put frypot cover(s) in place.

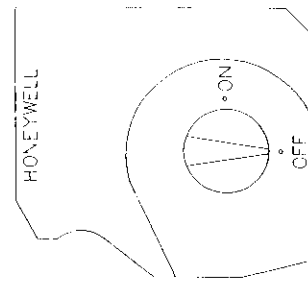

Figure 1

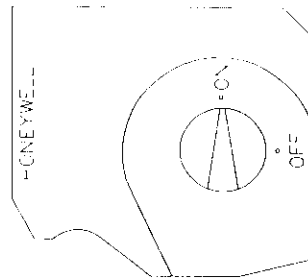

Figure 2

5. VENTILATION AND CLEARANCE

One of the important considerations of efficient fryer operation is ventilation. The fryer must be installed so that products of combustion are removed efficiently, and the kitchen ventilation system does not produce drafts that interfere with proper burner operation. The fryer flue opening must not be placed close to the intake of the exhaust fan.

The fryer must never have its flue extended in a "chimney" fashion. An extended flue will change the combustion characteristics of the fryer causing it to be slow to recover, and frequently causing delayed ignition.

To provide air flow necessary for good combustion and burner operation, the areas surrounding the fryer front(s), side(s), and rear must be kept clear and unobstructed.

The fryer(s) must be installed in an area with adequate air supply and ventilation.

Many operators do not realize that the finest ventilation system will break down when it is not maintained properly.

The duct system, the hood, and the filter bank must be cleaned on a regular basis and kept free of grease.

Adequate distances must be maintained from the flue outlet of the fryer to the lower edge of the filter bank. Filters should be installed at an angle of 45°, and a drip tray should be located beneath the lowest edge of the filter. For U.S. Installation, NFPA Standard No. 96 states that "A minimum distance of 18 in. (450mm) should be maintained between the flue outlet and the lower edge of the grease filter". We recommend that the MINIMUM DISTANCE BE 24 in. (600mm) FROM THE FLUE OUTLET TO THE BOTTOM EDGE OF THE FILTER WHEN THE APPLIANCE CONSUMES MORE THAN 120,000 BTU PER HOUR. Information on construction and installation of ventilating hoods can be found in the NFPA Standard above. A copy of this standard may be obtained from the National Fire Protection Association, Battery March Park, Quincy, Mass. 02269.

6. DRAINING AND FILTERING INSTRUCTIONS

WARNING

Draining and filtering of shortening must be accomplished with care to avoid the possibility of a serious burn caused from careless handling.

FILTERING

If you are using a filter other than the Frymaster Filter Magic, consult the filtering manufacturer's operation instructions for recommended filtering procedure. Instructions for using the Filter Magic are included in Section 14, Filtration, of this manual.

The following procedure is recommended to drain and filter your shortening when a filter machine is not available.

1. Press the fryer power switch to OFF. Screw the drain pipe provided with the fryer into the drain valve. Make sure the drain pipe is firmly screwed into the drain valve and that the curved end is pointing downward. (Figure 3.)
2. Position a safe metal container with sealable cover under the drain pipe. The container must be of sufficient design to withstand the hot shortening and must be able to hold liquids. Frymaster recommends that a Frymaster filter cone holder and filter cone be used when a filter machine is not available. If you are using the Frymaster filter cone holder and cone, be sure that the cone holder rests securely on the metal container.

3. Open the drain valve slowly to avoid splattering. If splattering occurs, exercise extreme caution.
4. If the drain valve becomes clogged with food particles, you may wish to use the FRYER'S FRIEND (poker like tool). This tool must be used from INSIDE the frypot ONLY. Carefully grip the tool as far as possible away from the shortening in the frypot. DO NOT hammer on the drain valve as damage to the ball inside will cause it to leak. DO NOT insert into front of drain valve in an attempt to unclog the valve; hot shortening will rush out creating the potential for injury. (See Figure 4.)
5. The drained shortening should be allowed to cool to 100°F (38°C) or lower before transporting the container and removing drain pipe.

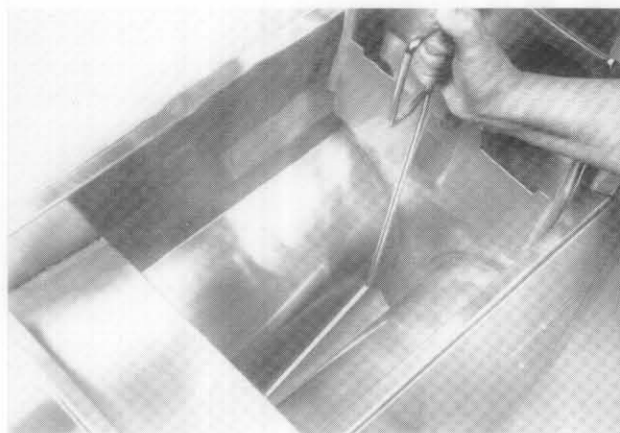

7. KFM-III COMPUTER FUNCTION IDENTIFICATION

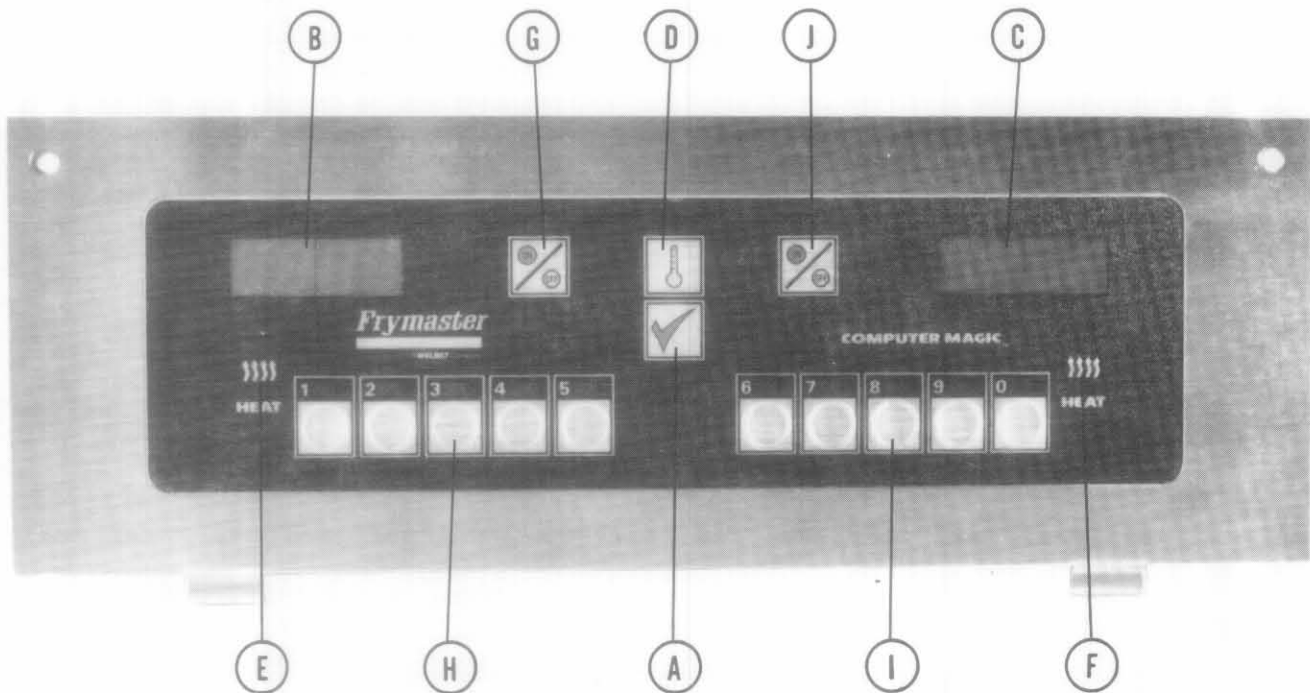

ITEM	DESCRIPTION	FUNCTION
A	Programming Switch	Used in programming the computer memory.
B	Lighted Display - Left Side	Displays various functions and operations.
C	Lighted Display - Right Side	Displays various functions and operations.
D	Storage and Temperature Check Switch	Locks program in computer and/or displays temperature.
E	Heating Indicator Light - Left Side	Indicates when burner is on.
F	Heating Indicator Light - Right Side	Indicates when burner is on.
G	Fryer ON/OFF Switch - Left Side	Turns fryer on and off.
H	Product and Coding Switch - Left Side	Used for computer access and programming functions.
I	Product and Coding Switch - Right Side	Used for computer access and programming functions.
J	Fryer ON/OFF Switch - Right Side	Turns fryer on and off.

8. KFM-III COMPUTER OPERATING INSTRUCTIONS

1. Turn fryer on by pressing ON/OFF Switch to "ON"; one of the following will be displayed:
 - a. The "HEATING" light will cycle on and off indicating the burner is operating in the melt cycle mode. Display will read "LO" until shortening reaches temperature of 255°F.
 - b. At 255°F and above, actual shortening temperature will be displayed until the temperature is in the cooking range.
 - c. "DROP", indicating that shortening temperature is in the cooking range. NOTE: For best results, cooking product should not be attempted unless display indicates "DROP".
 - d. "HELP", indicating that there has been a burner ignition problem.
 - e. At 390°F and above, the display will show "HI" and actual vat temperature.
 - f. "PROB", indicating that the computer has detected a problem in the temperature measuring circuits, including probe.
- a. The display will indicate the previously programmed cook time and begin countdown.
- b. If shake time is programmed, the operator will be notified of the need to shake the product "X" seconds or minutes before the end of the cook cycle. An alarm will sound, and the display will read "SH" (followed by the product switch number). If shake time is not desired, program in "0". The alarm is self canceling.
- c. At the end of cooking cycle, an audible alarm will sound, "DONE" will be displayed, and the associated product switch indicator will flash. To cancel the cook alarm, press the appropriate switch.
- d. During idle periods when the fryer is ready for use, "DROP" will be displayed.

CHECKING TEMPERATURE

4. Check the shortening temperature at any time by pressing Item A.
 - a. Should you suspect the probe is defective, check shortening with a good thermometer to verify that computer readout is reasonably close to measured reading.

NOTE: The "HEATING" light on computer panel indicates when burner is on.

2. The fryer will remain in the melt cycle mode until shortening temperature reaches 180°F.
3. Cook cycle operation is initiated by pressing product switch. Use "1" through "5" for left side split pot and "6" through "0" for right side split pot. All product switches may be used for full pot.

9. KFM-III COMPUTER PROGRAMMING INSTRUCTIONS

1. To enter program mode, press Switch, Item A. CODE will appear in the left display, Item B. If you have pressed this switch in error and do not wish to program, press switch again. If programming is not allowed because computer is in non-programmable mode, display will flash "BUSY".
2. Enter Code Number: Press "1", "6", "5", "0" in that sequence. Your program will not be accepted unless these numbers are entered. This prevents an unauthorized person from changing your preset instructions.
3. SP-R (Set Point) will appear in display. This is for setting cooking temperature in right side of pot. The temperature previously selected will be displayed in Item C. Enter the new temperature desired. To lock this temperature in, press Item A. The display now shows SP-L (Set Point Left Side). Follow the same procedures to change cooking temperature for left side of pot. If you do not want to change any settings, press Item A. On full vat fryers, SP-R only will be displayed.
4. SELP (Select Product Switch) will appear in display. Any switch with flashing LED may be programmed. Press product switch to be programmed.
5. SENS (sensitivity) will appear in display. Sensitivity range is from 0-9. The recommended number to begin with is "4". The number you select will be displayed.

NOTE: SENS — Sensitivity is a built-in feature that causes the computer to adjust cooking time to compensate for the drop in shortening temperature when a basket of product is placed in the fryer. Some experimenting with the range may be required to obtain the desired quality.

6. DONE (Cooking Time) will now be displayed. Enter proper cooking time. Press Item A.
7. SH-X (Shake Time) will appear in display. If your product requires shaking during the cooking process, set the time by pressing the number of minutes and/or seconds remaining in the cooking cycle before shaking. This number will appear in display. If you do not wish to enter a shake time, enter "0" and press Item A.
8. SELP will be displayed. If you desire to program more products, return to Step 4. If no more programming is required, lock in program by pressing , Item D.

SPECIAL FUNCTIONS

CODE "1", "6", "5", "8" Select Celsius or Fahrenheit Temperature Display.

NOTE: The electronic circuitry can be affected adversely by current fluctuations and electrical storms. Should it not function or program properly for no apparent reason, the computer should be reset by unplugging fryer and plugging it back in. This could eliminate a service call.

10. ACCESSORIES

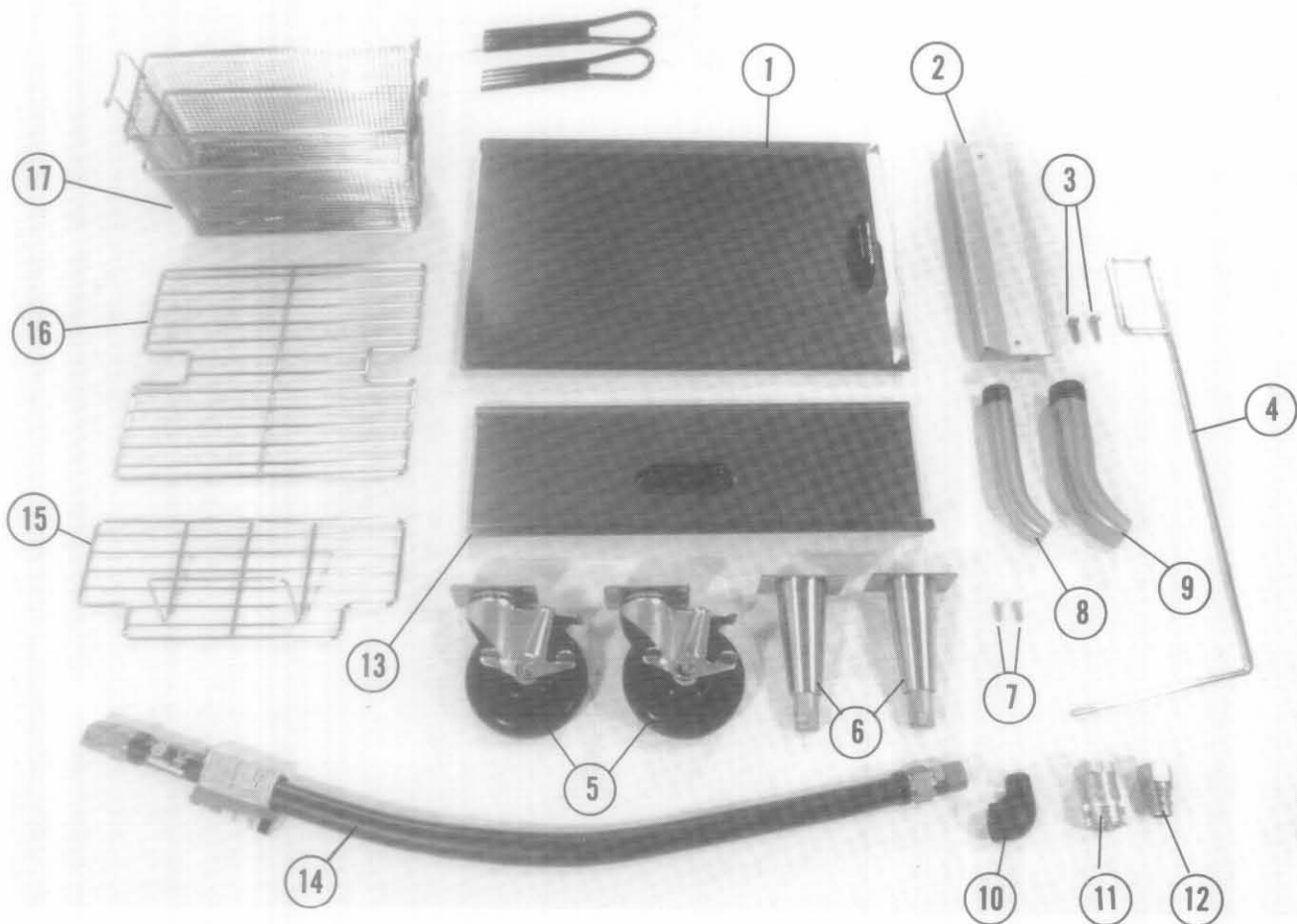

ITEM	PART NUMBER	DESCRIPTION
1	806-1341	Pot Cover, Full Pot
2	803-0028	Basket Hanger
3	809-0171	Basket Hanger Screw
4	803-0197	Clean-out Rod
5	810-0357	Caster, Locking 5"
5	810-0651	Caster, FPH-50 3"
6	806-5043	Leg, Adjustable
7	809-0131	Screw, Leg and Caster Mounting
8	813-0276	Drain Nipple, Split Pot
9	813-0188	Drain Nipple, Full Pot
10	813-0168	Street El, 3/4"
11	810-0070	Quick Connect Female 3/4" (1.9 cm)
11	810-0073	Quick Connect Female 1" (2.5 cm)
12	810-0072	Quick Connect Male 3/4" (1.9 cm)
12	810-0074	Quick Connect Male 1" (2.5 cm)
13	806-3232	Pot Cover, Split Pot
14	810-0083	Flex Gas Hose 3/4" (1.9 cm) x 48" (122 cm)
14	806-1699	Flex Gas Hose 1" (2.5 cm) x 48" (122 cm)
15	803-0133	Basket Support, Split Pot
16	803-0033	Basket Support, Full Pot
17	803-0022	Basket, Twin

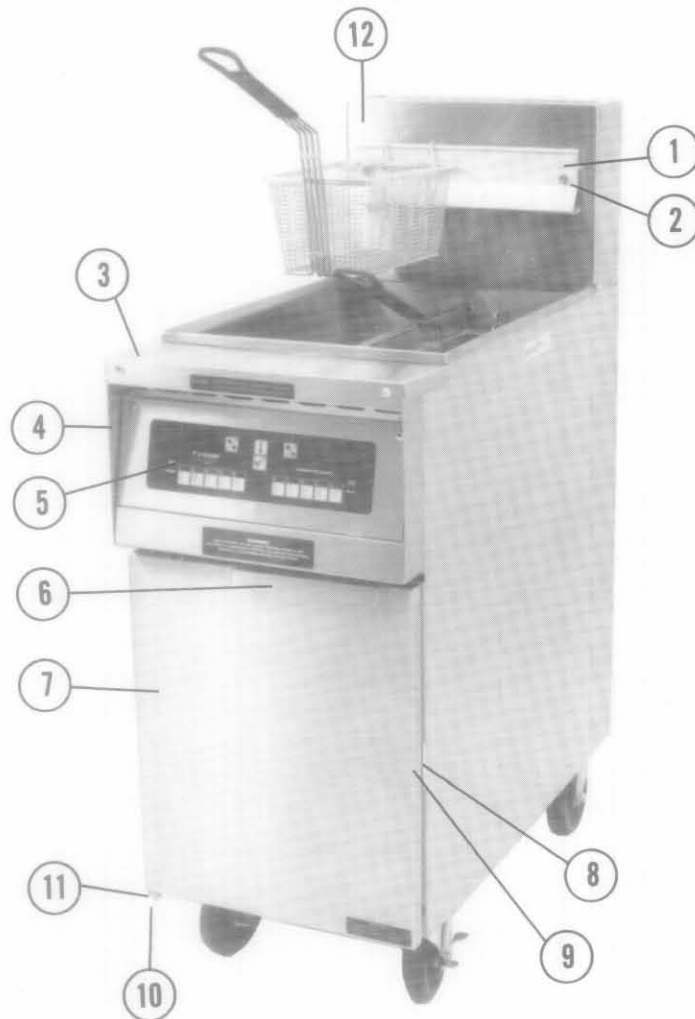

ITEM	PART NUMBER	DESCRIPTION
1	803-0028	Basket Hanger
2	809-0171	Basket Hanger Screw
3	910-3544	Top Cap
3	823-0586	Top Cap, Double
3	823-0587	Top Cap, Triple
3	823-0588	Top Cap, Four Unit
4	823-0767	Control Panel Frame
4	806-4733	Control Panel Frame, Double
4	806-4734	Control Panel Frame, Triple
5	806-4967	Computer, Split Vat
5	806-4966	Computer, Full Vat
6	910-3672	Door Handle
7	806-1962	Door, Universal, SS
7	806-1961	Door, Universal, Painted
8	900-00481	Door Striker Plate
9	810-0068	Magnetic Door Catch
10	809-0216	Door Hinge Pin
11	900-03471	Door Hinge Bracket
12	910-6545	Flue Cap

11. TROUBLESHOOTING GUIDE

WARNING:

Inspection, testing and repair of electrical equipment should be performed only by qualified service personnel. The unit should be unplugged when servicing, except when electrical tests are required.

NOTE: This guide does not include every possible problem and the cause. However, careful observation of all malfunction indications and logical troubleshooting will help in correcting the problem in a more expedient manner.

DANGER:

Use extreme care during electrical circuit tests. Live circuits will be exposed.

PROBLEM (DISPLAYED)	PROBABLE CAUSE	CORRECTIVE ACTION
FULL POT ON/OFF SWITCH ON: Display Shows "HELP", Alarm Sounding, Heat Indicator Cycles ON, All Appropriate Interface Board LED'S ON, Burners Will Not Fire.	A. Drain valve not fully closed.	A. Press ON/OFF switch OFF, close drain valve, press ON/OFF switch ON.
	B. Defective or misadjusted drain valve microswitch.	B. Adjust or replace drain valve switch and repeat step "A" above.
	C. Gas valve knob in OFF position	C. Rotate gas valve knob to ON position and repeat step "A" above.
	D. Hi-limit thermostat defective or stuck open.	D. Have service agent check hi-limit. Replace if defective.
	E. Improper combustion air mixture to burners.	E. Check combustion air to burners. (See "Check Air Adjustment in Section 13.)
	F. Blower air inlet and impeller dirty.	F. Remove blower and clean.
ON/OFF Switch ON: Display Shows "PROBE", Alarm Sounding, Heat Indicator OFF.	A. Open or shorted probe.	A. Have service agent check. Replace probe if found defective.
	B. Defective computer.	B. Have service agent test computer with Frymaster MTB-310A tester. Replace if found to be defective.
No Display on Computer. All Interface Board LED'S OFF.	A. No power to fryer.	A. Check fryer power supply. <ol style="list-style-type: none"> 1. Power cord unplugged. 2. Reset fire protection system circuit breaker.
No Display on Computer. Interface Board LED #3 ON LED #6 ON.	A. Defective computer.	A. Swap computer with another fryer. Replace if found defective.
FULL POT Fryer Slow Coming Out of Melt Cycle. Display Shows "HELP" a Short Time After Coming Out of Melt Cycle.	A. One burner not firing due to restricted air flow from blower.	A. Clean combustion air blower and perform burner combustion air adjustment.
	B. Burner gas pressure low.	B. Have service agent check and adjust burner gas pressure.

PROBLEM (DISPLAYED)	PROBABLE CAUSE	CORRECTIVE ACTION
<p>FULL or SPLIT POT</p> <p>ON/OFF Switch ON, Heat Indicator OFF</p> <p>After Initial Startup, Display Shows "HI, HOT" With Alarm Sounding.</p>	<p>A. Defective computer.</p>	<p>A. Swap computer with another fryer. Replace if found defective.</p>
<p>FULL or SPLIT POT</p> <p>ON/OFF Switch On. Display Shows "HELP", Alarm Sounding. Fryer Op- erating Normally</p>	<p>A. Defective computer.</p>	<p>A. Swap computer with another fryer. Replace if found defective.</p>
<p>Computer Will Not Go Into Program- ming Mode.</p>	<p>A. Computer buttons shorted.</p>	<p>A. Swap computer with another fryer. Replace if found defective.</p>
<p>FULL OR SPLIT POT</p> <p>Fryer Operating Normally, but Pro- duces Popping Sound When Burn- ers Fire.</p>	<p>A. Blower air inlet and impeller dirty.</p> <p>B. Vent tube on gas valve clogged causing high burner gas pres- sure.</p>	<p>A. Remove blower and clean.</p> <p>B. Remove gas valve vent tube and clean with binding wire and reinstall.</p>

12. SERVICE PROCEDURES

WARNING

Before performing any maintenance on your Frymaster fryer, you must disconnect the electrical power supply and gas supply line.

When electrical wires are disconnected, it is recommended that each wire be marked to facilitate reassembly.

Procedure 1: Replacing Computer

1. Unscrew 2 control panel screws.
2. Control panel is hinged at the bottom and will swing open from the top.
3. Unplug wiring harness at plug on back of computer. (See Figure 3.)

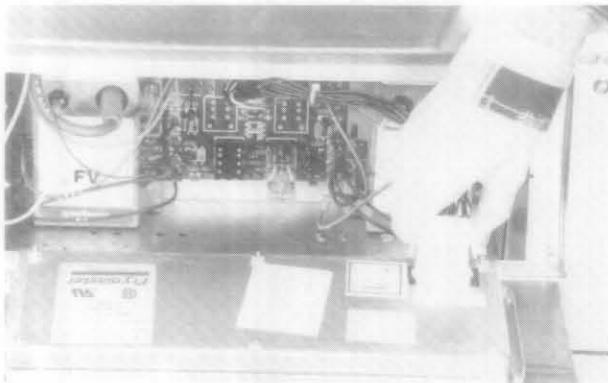
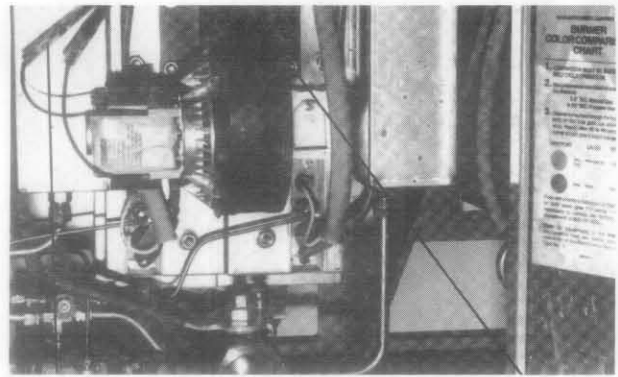

Figure 3

4. Computer can be removed by lifting the assembly from the hinged slots in the control frame.
5. Reverse procedures to install new computer.

Procedure 2: Replacing or Cleaning Combustion Air Blower Assembly

1. Disconnect wires from the blower assembly. (See Figure 4.)
2. Remove 4 1/4" (6mm) nuts at flange of blower housing. (See Figure 4.)
3. Slide blower housing assembly from mounting studs. (See Figure 4.)



WIRES

Figure 4

NUTS

4. Remove 3 lock nuts from blower motor mounting plate. (See Figure 5.)

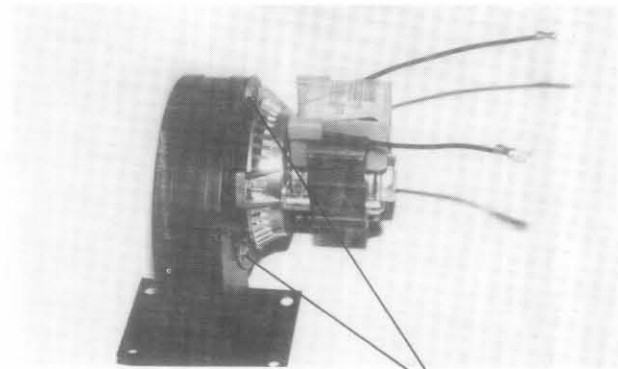

Figure 5

LOCK NUTS

5. Slide blower and motor assembly out of blower housing. (See Figure 6.)

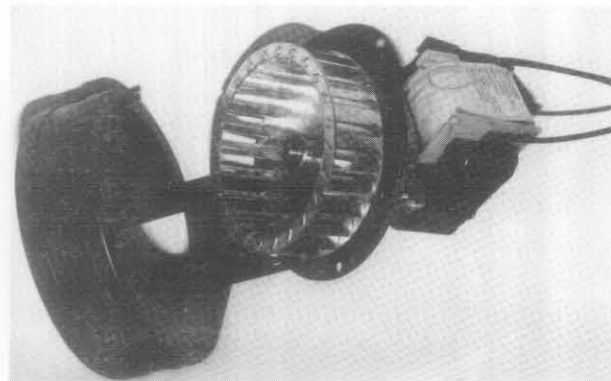

Figure 6

6. To clean blower wheel, wrap motor with plastic wrap to prevent water from entering motor. Spray degreaser detergent on the blower wheel. Allow wheel to set five minutes, then rinse under a hot water faucet. Dry with a clean, dry cloth.
7. Spray blower housing with degreaser inside and outside. Allow housing to set for five minutes, then rinse under a hot water faucet. Dry with a clean, dry cloth.
8. Remove the plastic wrap from blower motor and reassemble motor and wheel to housing.

9. Reinstall blower by reversing above procedure.
10. Perform air adjustment as specified in PREVENTIVE MAINTENANCE, No. 8 and Step 11 below.
11. If air adjustment is required, loosen the locking nut on the air blower adjusting plate with an adjustable wrench. Open or close the adjusting plate to obtain maximum orange-red glow on face of burner. Tighten locking nut.

NOTE: A blue flame observed through the burner viewing port indicates insufficient air. Dark spots on burner face indicates excess air.

Procedure 3: Cleaning Gas Valve Vent Tube

1. Unscrew vent tube from gas valve. (See Figure 7.)
2. To clean out the vent tube, insert a piece of small wire through the tube to remove any obstruction.
3. Remove the wire and blow through the tube.
4. To reinstall the vent tube reverse procedure.

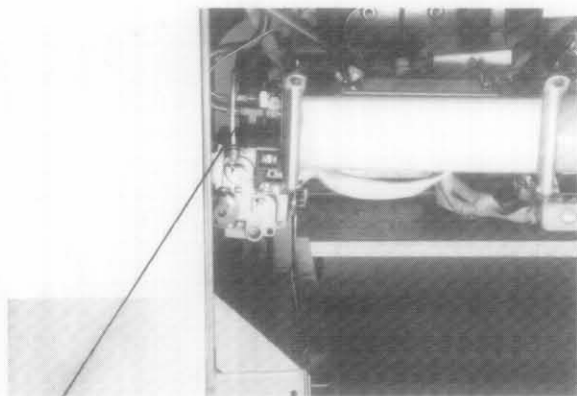

VENT TUBE

Figure 7

13. PREVENTIVE MAINTENANCE

1. CLEAN INSIDE AND OUTSIDE OF FRYER CABINET — DAILY

To clean inside the fryer cabinet, use a dry, clean cloth and wipe all accessible metal surfaces and components to remove accumulated film of shortening and dust.

To clean outside the fryer cabinet, use a clean damp cloth soaked with dishwashing detergent and wipe clean of all shortening, dust, and lint. Rinse with a clean, damp cloth.

2. CLEAN FRYPOT — ONCE A WEEK

WARNING

NEVER operate the fryer(s) with an empty frypot.

3. CLEAN DETACHABLE PARTS AND ACCESSORIES — ONCE A WEEK

Wipe all detachable parts and accessories with a clean, dry cloth. If a heavy film of carbonized shortening has accumulated on the detachable parts and accessories, a clean cloth saturated with Frymaster Fryer 'N' Griddle Cleaner may be used to remove the film. Rinse the parts and accessories thoroughly with clean water and wipe dry before reinstalling on fryer(s).

4. CHECK CALIBRATION OF FRYER WITH SOLID-STATE THERMOSTAT CONTROL PANEL — ONCE A MONTH

To check calibration, refer to THERMOSTAT CALIBRATION, Section 7.

5. CLEAN COMBUSTION AIR BLOWER — EVERY 6 MONTHS

To clean the combustion air blower, remove three (3) blower motor flange screws or nuts located at the left side of the blower housing. The blower motor and blower wheel will lift out of housing. To clean blower wheel, wrap motor with plastic wrap to prevent water from entering motor. Spray degreaser detergent on the blower wheel. Allow wheel to set five minutes, then rinse under a hot water faucet. Dry with a clean, dry cloth. Spray blower housing with degreaser inside and outside. Allow housing to set for five minutes, then rinse under a hot water faucet. Dry with a clean, dry cloth. If motor incorporates oil provisions, lubricate every six months with

S.A.E. 20 oil. Reinstall blower and motor in reverse sequence after cleaning. For illustrations, see Service Procedure 2.

6. CLEAN GAS VALVE VENT TUBE — EVERY 6 MONTHS

To clean gas valve vent tube, unscrew vent tube fitting from gas valve and remove tube. Insert a piece of ordinary binding wire through the vent tube to remove any obstruction in the tube. Remove clean-out wire and blow through the tube. Reinstall the vent tube with the open-end pointing toward rear of fryer and slightly toward floor.

7. CHECK BURNER MANIFOLD PRESSURE — EVERY 4 TO 6 MONTHS

3.5 inches (0.75 kPa) W.C. NATURAL GAS
8.25 inches (2.0 kPa) W.C. LP GAS

Only qualified personnel should perform this task. To check burner manifold pressure, ensure that gas valve knob is turned to the OFF position. Remove pressure tap plug from enrichment tube fitting above gas valve. Insert fitting for gas pressure measuring device into pressure tap hole. Turn gas valve to ON position and turn fryer power switch ON. When burner lights and continues to run, monitor gas pressure reading for correct pressure. To adjust burner gas pressure, remove cap from gas valve regulator and adjust to correct pressure. Turn fryer switch off and gas valve knob off. Remove fitting from enrichment fitting and reinstall pressure tap plug.

8. CHECK AIR ADJUSTMENT — EVERY 4 TO 6 MONTHS

A blue flame observed through the viewing port indicates insufficient air. This can be corrected by loosening lock nut on blower air adjustment plate and rotate plate open until maximum red glow is obtained on burner. (Microamp reading should be 3-6 microamps with micro ammeter connected in series with spark ignition sensor wire.) Dark spots on burner indicate excess air. To correct this condition, rotate plate closed until maximum red glow is obtained on burner. After adjustment is completed, lock air adjustment plate in position with locking nut.

14. FILTRATION

OPERATING INSTRUCTIONS

PREPARING THE FILTER UNIT FOR USE

1. Remove the filter unit from the cabinet.
2. Remove the crumb tray and the paper hold-down ring.

NOTE: Be sure the inside of the pan is free of all food and breading particles that could prevent the paper from sealing against the bottom of the pan and clogging the Power Shower with crumbs.

3. Position the support screen in the pan with the 90° lip down.
4. Position the filter paper on top of the support screen with the edges evenly distributed.
5. Insert the paper hold-down ring and push down against outer edges of paper until ring is against bottom of pan. Add powder per instructions on package and insert the crumb tray in the filter pan.
6. Roll the filter pan back into the fryer cabinet, making sure that it is positioned all the way to the back of the cabinet. When the filter pan is properly positioned, the green system ready light located on the filter control panel will come on.

OPERATION OF THE FILTER UNIT

CAUTION:

Never operate the filter unit unless the fryers have been brought up to cooking temperature.

1. To filter the fryer, turn the fryer power OFF, open the drain valve on the fryer you have selected to be filtered, and use the Fryer's Friend steel rod to free the drain from inside the frypot as necessary.

NOTE: Exercise care when using the Fryer's Friend to prevent damage to the frypot and drain valve.

CAUTION: Do not drain more than one fryer at a time. To do so, will cause overflowing of the filter pan.

NOTE: On fryers with the rear-flush option, the control lever is located on the square drain. You can select Power Shower or cold zone flush. The cold zone flush will wash sediment from the bottom of the frypot.

NOTE: Filter pump is equipped with a manual reset switch in case the filter motor overheats or an electrical fault occurs.

WARNING

Turn off power to filter system and allow pump motor to cool 20 minutes before attempting to reset switch on pump motor.

2. After shortening is completely filtered, close the drain valve and allow the fryer to fill before disengaging the filter lever to turn off the filter pump.

NOTE: When using solid shortening, allow the filtering system to run five (5) to ten (10) seconds after bubbles appear in order to clear the lines and to prevent solid shortening from hardening in the line and clogging the filter.

3. Turn the fryer ON to start the cooking operation.

CAUTION:

Extreme care must be exercised when working with hot shortening. Never use the filter pan to dispose of used shortening. Use an SDU (Shortening Disposal Unit) or stock pot to transport used shortening to the disposal area.

CHANGING THE FILTER PAPER

NOTE: Allow filter pan to cool completely before attempting to change the paper.

1. Remove the filter pan from the fryer cabinet.
2. Remove and clean the crumb tray.
3. Remove the hold-down ring from the filter pan.
4. Remove and discard the used (old) filter paper.
5. Remove filter paper screen and clean.
6. Clean all breading and food particles from the filter pan.

NOTE: Inner pan may be removed from the outer pan assembly for cleaning.

7. Refer to the section PREPARING THE FILTER UNIT FOR USE for the next operation.

CARE AND CLEANING OF FRYER FILTERING SYSTEM

CAUTION:

Never operate the fryer or filtering system without shortening in the system.

The shortening should be filtered as often as needed. If a heavy volume of breaded food is fried, it may be necessary to filter as often as every hour. This will increase the life of the shortening and produce a better-tasting product. The best rule to follow is to filter before you think it is needed. Even with a product such as french fries, you should filter two (2) to three (3) times per day for best results.

Also, the frypot should be cleaned periodically. This operation, combined with the disposing of the used shortening, enhances the flavor of the food product. After the fryer has been emptied, the frypot should be drained and the drain valve closed. Fill the frypot to the oil-level line with water and the correct amount of Frymaster Fryer N' Griddle Cleaner, then put the baskets into the frypot and bring the solution to a simmer condition for one (1) hour. Then turn OFF the fryer, drain the solution, and wipe the frypot clean and dry.

NOTE: Do not drain water into the filter pan. Water will damage the filter pump, necessitating replacement. Use a stock pot or bucket. The inner and outer filter pan must be cleaned on initial startup and periodically thereafter.

1. To clean the inner filter pan, remove from outer pan and take to a sink filled with warm water and grease-cutting detergent.
2. Scrub the inner pan with a nylon pot brush.
3. When clean, rinse thoroughly to remove all detergent and wipe dry with a clean, dry cloth or paper towels.
4. To clean the outer filter pan, pour one (1) quart (one (1) liter) of warm water mixed with grease-cutting detergent into the pan. Scrub the pan thoroughly inside **ONLY** with the pot brush until clean.
5. Pour the solution from the outer pan into kitchen drain or sink.
6. Rinse with clean water and drain into kitchen drain or sink.
7. Turn the pan upside down and slightly elevate on sink drain board to allow all water to drain from suction tube.

Caution:

All water must be removed from the suction tube before inserting inner pan.

8. After suction tube is free of water, wipe inside and outside with a clean, dry cloth or paper towels.
9. Insert inner pan back into outer pan and refer to Step 3 of PREPARING THE FILTER UNIT FOR USE.

POWER SHOWER CARE AND CLEANING

The stainless steel Power Shower assembly practically cleans itself as the hot shortening is forced through the tubing during the filtration process. However, the operator must be sure to drain the Power Shower thoroughly once it is removed from the fryer, after the filtering operation is completed.

To check for any stoppage in the tubing:

1. Remove the plugs at each corner of the Power Shower frame.
2. Insert a long, narrow bottle brush into the tube to dislodge any particles. Hot water and grease-cutting detergent may be used in conjunction with the bottle brush to clean inside the Power Shower tube.

NOTE: When hot water and detergent are used to clean the Power Shower, the Power Shower must be rinsed, thoroughly dried, and plugs reinserted before reusing.

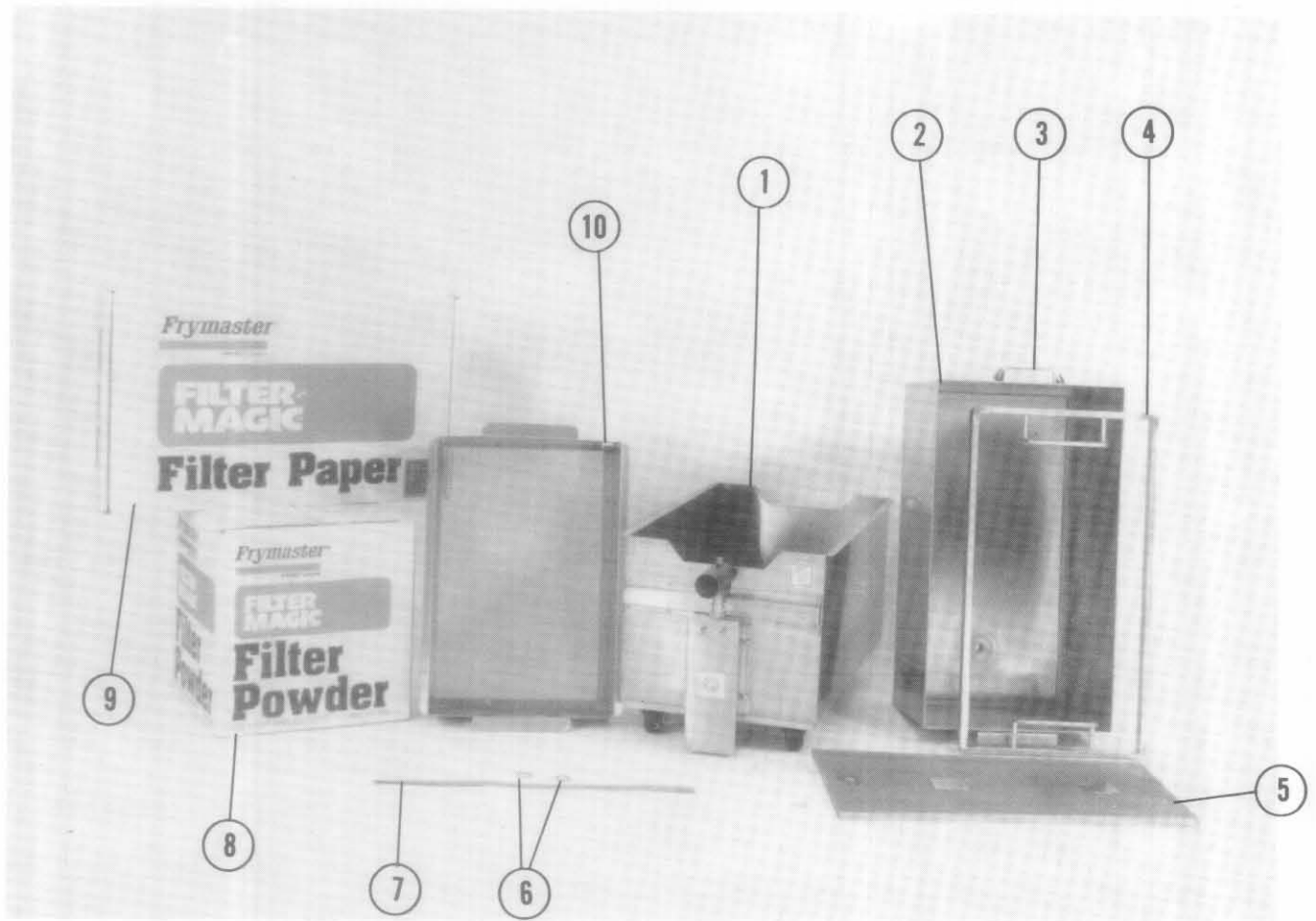

FILTER MAGIC II PARTS LIST

ITEM	PART NUMBER	DESCRIPTION
1	806-4338	Pan, Outer (Complete)
2	806-4859	Pan, Inner
3	810-0180	Handle, Inner Pan
*	809-0024	Screw, Handle
4	823-17331	Filter Paper Hold-down Ring
5	823-1732	Screen, Filter Pan
6	816-0117	O-ring, Inner Pan Fitting
7	806-4373	Pan Heater
8	803-0002	Filter Powder
9	803-0170	Filter Paper
10	824-0416	Crumb Screen
*	826-1051SP	O-ring Kit for Filter System

*Not illustrated.

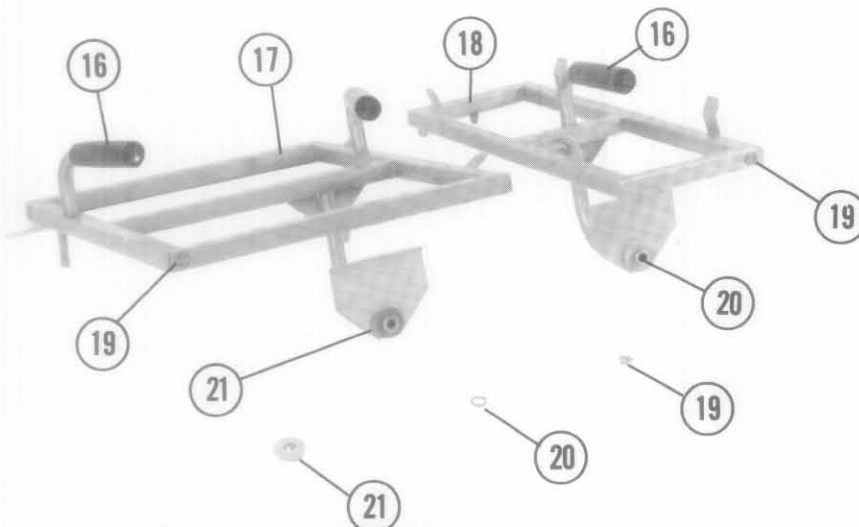
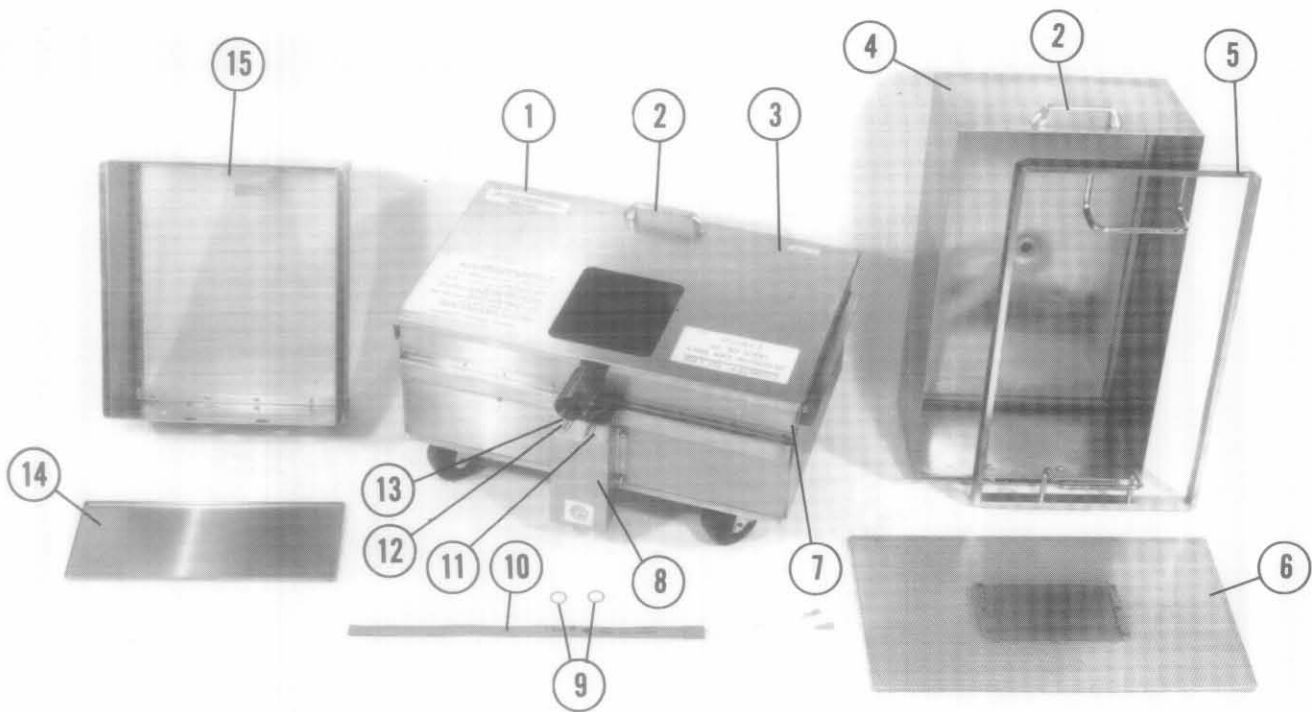

FOOTPRINT II PARTS LIST

ITEM	PART NO.	DESCRIPTION	ITEM	PART NO.	DESCRIPTION
1	806-4370SP	Outer Pan Assembly (prior to ser. AK)	10	806-4373	Pan Heater
1	806-5412	Outer Pan Assembly, Series AK	11	810-0695	Contactora Pan Heater
2	810-0180	Handle, Outer Pan Cover	12	807-1367	Insulator Filter Contacts
*	809-0024	Screw, Handle	13	807-1270	Insulator Shoulder
3	823-1397	Cover, Outer Pan (prior to ser. AK)	14	910-4240	Drip Pan
3	823-1945	Cover, Outer Pan, Series AK	15	823-1423	Crumb Screen
4	806-4771	Inner Pan Assembly	16	814-0001	Handle Grip
5	823-16631	Filter Paper Hold-down Ring	17	806-4442	Power Shower, Full Vat
6	823-1664	Screen, Filter Pan	18	806-4476	Power Shower, Split Vat
*	803-0002	Filter Powder	19	809-0415	Power Shower Clean-Out Screw
*	803-0170	Filter Paper, High Performance	20	816-0071	O-ring, Power Shower
7	809-0422	Pan Cover Hinge Screw	21	816-0025	Gasket, Power Shower
8	824-0246	Cover, Suction Tube	*	826-1051SP	O-ring Kit for Filter System
9	816-0117	O-Ring, Inner Pan Fitting			

*Not illustrated.

15. FILTER SYSTEM TROUBLESHOOTING

PROBLEM	PROBABLE CAUSE	CORRECTIVE ACTION
Filter heat light does not glow.	A. Filter pan not in position.	A. Position pan properly.
Filter heater will not heat.	A. Pan not in position	A. Position pan properly.
Pump will not pump.	A. Pan not in position. B. Broken o-ring on fitting. C. Shortening solidified in pan. D. Thermo overload tripped on pump motor.	A. Position pan properly. B. Replace o-ring. C. Allow heater to melt shortening. D. Reset thermo overload on pump motor.
Fryer trouble light ON or computer shows "HELP."	A. Drain switch not closed. B. Microswitch out of adjustment.	A. Close drain valve. B. Adjust switch.
Drain tube leaking.	A. Defective gasket. B. Loose clamp on square drain.	A. Replace gasket. B. Tighten clamp.
Filter Power Shower not spraying properly.	A. Blockage in Power Shower. B. Filter pan connection not properly engaged. C. Shower assembly not properly installed. D. O-ring lost or defective on Power Shower.	A. Remove Power Shower clean-out plugs and clean. B. Position pan properly. C. Install properly. D. Replace o-ring.