

75 74

FM45E, MJ45E, MJ45EC

SERVICE MANUAL

MJ45E SERIES



Frymaster®

Frymaster L.L.C., 8700 Line Avenue 71106, P.O. Box 51000, Shreveport, Louisiana 71135-1000
318-865-1711 FAX 318-868-5987

Printed in U.S.A.

SERVICE HOTLINE
1-800-551-8633

Price \$4.00
819-5115 12/92



TABLE OF CONTENTS

MJ45E FRYER

SECTION	PAGE NO.
1. PARTS ORDERING/SERVICE INFORMATION.....	1
2. IMPORTANT INFORMATION.....	2
3. INSTALLATION INSTRUCTIONS.....	2
PROPER INSTALLATION.....	2
FRYERS EQUIPPED WITH CASTERS.....	3
NATIONAL CODE REQUIREMENTS.....	3
ELECTRICAL GROUNDING INSTRUCTIONS.....	3
GAS CONNECTIONS AND PIPE SIZE.....	3
FRYERS EQUIPPED WITH FRYMASTER COMPUTERS.....	4
AFTER FRYER IS UNDER FRY STATION EXHAUST HOOD.....	4
4. OPERATING INSTRUCTIONS.....	5
BOILING OUT FRYPOT.....	5
FILLING WITH SHORTENING.....	5
LIGHTING INSTRUCTIONS.....	5
ACCESSING FRYERS FOR SERVICING.....	6
SHUTTING FRYERS OFF FOR SHORT PERIODS.....	6
SHUTTING FRYERS OFF WHEN CLOSING STORE.....	6
5. VENTILATION AND CLEARANCE.....	6
6. DRAINING AND FILTERING INSTRUCTIONS.....	7
7. SOLID-STATE THERMOSTAT CONTROL PANEL.....	8
8. COMPUTER MAGIC III CONTROL PANEL — OPERATING INSTRUCTIONS.....	9
9. COMPUTER MAGIC III CONTROL PANEL — PROGRAMMING INSTRUCTIONS.....	11
10. ELECTRONIC TIMER CONTROLLER.....	14
11. DIGITAL SOLID-STATE CONTROLLER.....	16
12. TROUBLESHOOTING — FRYER WITH COMPUTER MAGIC III, BASKET LIFT TIMER, OR DIGITAL CONTROLLER.....	18
13. TROUBLESHOOTING — FRYER WITH SOLID-STATE CONTROLLER AND THERMOSTAT KNOB.....	21
14. TROUBLESHOOTING — FRYER EQUIPPED WITH STANDARD THERMOSTAT.....	23
15. PARTS LIST.....	26
16. SERVICE PROCEDURES.....	41
17. PREVENTIVE MAINTENANCE.....	55
18. WIRING DIAGRAMS.....	56
19. INTERFACE BOARD.....	62
20. SPECIFICATIONS.....	63
FILTRATION.....	65
BASKET LIFTS.....	70

WARNING
IMPROPER INSTALLATION, ADJUSTMENT, ALTERATION, SERVICE OR MAINTENANCE CAN CAUSE PROPERTY DAMAGE, INJURY OR DEATH. READ THE INSTALLATION, OPERATING AND MAINTENANCE INSTRUCTIONS THOROUGHLY BEFORE INSTALLING OR SERVICING THIS EQUIPMENT.

WARNING
FOR YOUR SAFETY
DO NOT STORE OR USE GASOLINE OR OTHER FLAMMABLE VAPORS OR LIQUIDS IN VICINITY OF THIS OR ANY OTHER APPLIANCE

POST IN PROMINENT LOCATION THE INSTRUCTIONS TO BE FOLLOWED IN THE EVENT THE USER SMELLS GAS. THIS INFORMATION CAN BE OBTAINED BY CONSULTING THE LOCAL GAS SUPPLIER.

WARNING
THIS PRODUCT CONTAINS CHEMICALS KNOWN TO THE STATE OF CALIFORNIA TO CAUSE CANCER AND/OR BIRTH DEFECTS OR OTHER REPRODUCTIVE HARM. ¹Operation, ²installation and ³servicing of this product could expose you to airborne particles of glasswool fibers and/or carbon monoxide. Inhalation of airborne particles of glasswool fibers is known to the State of California to cause cancer. Inhalation of carbon monoxide is known to the State of California to cause birth defects or other reproductive harm.

NOTICE
The Commonwealth of Massachusetts requires any and all gas products to be installed by a licensed plumber or pipe fitter.

1. PARTS ORDERING/SERVICE INFORMATION

Parts orders must be placed directly with your local Frymaster Parts Distributor. A list of Frymaster Parts Distributors was included with the fryers when shipped from the factory. If you do not have access to this list, please contact the Service Department at Frymaster 1-800-551-8633 or 1-318-865-1711.

To help speed up your order, the following information is required.

Model Number: _____

Serial Number: _____

Type of Gas or Voltage: _____

Part Number: _____

Quantity Required: _____

Service information may be obtained by calling your local Factory Authorized Service Center. A list of these agencies was packed with your fryer. Service

information may also be obtained by calling the Frymaster Service Department. When calling, please have the following information available:

Model Number: _____

Serial Number: _____

Type of Gas or Voltage: _____

Nature of service problem: _____

Any other information that may be helpful in solving your service problem.

PARTS ORDERING/SERVICE INFORMATION
CANADA — Garland Commercial Ranges, Ltd.,
1177 Kamato Road, Mississauga, Ontario L4W
1X4.

NOTE: RETAIN AND STORE THIS MANUAL IN A SAFE PLACE FOR FUTURE USE. ADDITIONAL COPIES MAY BE OBTAINED FROM YOUR AUTHORIZED SERVICE CENTER.

2. IMPORTANT INFORMATION

INTRODUCTION

The MJ45E Series are deep-well, open-pot fryers designed for cooking fried products. These models are available in full pot arrangement manufactured to operate on the type gas specified by the user; i.e., natural, propane, or manufactured gas. The instructions contained in this manual should be read thoroughly before attempting to operate these fryers.

This equipment is made in America and has American sizes of hardware. All hardware metric conversions are approximate and can vary in size.

OPERATING, INSTALLATION, AND SERVICE PERSONNEL

Operating information for FRYMASTER equipment has been prepared for use by qualified and/or authorized operating personnel.

All installation and service on FRYMASTER equipment must be performed by qualified, certified, licensed, and/or authorized installation or service personnel.

DEFINITIONS

QUALIFIED AND/OR AUTHORIZED OPERATING PERSONNEL

Qualified or authorized operating personnel are those who have carefully read the information in this manual and have familiarized themselves with the equipment functions or have had previous experience with the operation of equipment covered in this manual.

QUALIFIED INSTALLATION PERSONNEL

Qualified installation personnel are: individuals, a firm, corporation, or a company which either in person or through a representative are engaged in, and are responsible for the installation of gas-fired appliances. Qualified installation personnel must be experienced in such work, be familiar with all gas precautions required, and have complied with all requirements of state and local codes.

QUALIFIED SERVICE PERSONNEL

Qualified service personnel are those familiar with FRYMASTER equipment and have been authorized by THE FRYMASTER CORPORATION. All authorized service personnel are required to be equipped with a complete set of service parts manuals and stock a minimum amount of parts for FRYMASTER equipment.

A list of Frymaster Factory Authorized Service Centers was included with the fryer when shipped from the factory. If you do not have access to this list, please contact the Frymaster Customer Service Department, using the number listed on the front of this manual. Failure to use qualified service personnel will void the Frymaster warranty.

SHIPPING DAMAGE CLAIM PROCEDURE

For your protection, please note that the FRYMASTER equipment was carefully inspected and packed by skilled personnel before leaving the factory. The transportation company assumes full responsibility for safe delivery upon acceptance of the equipment.

What to do if equipment arrives damaged:

1. FILE CLAIM FOR DAMAGES IMMEDIATELY — Regardless of extent of damage.
2. VISIBLE LOSS OR DAMAGE — Be sure this is noted on the freight bill or express receipt and is signed by the person making the delivery.
3. CONCEALED LOSS OR DAMAGE — If damage is unnoticed until equipment is unpacked, notify freight company or carrier immediately, and file a "concealed damage" claim. This should be done within fifteen (15) days of date of delivery. Be sure to retain container for inspection.

FRYMASTER DOES NOT ASSUME RESPONSIBILITY FOR DAMAGE OR LOSS INCURRED IN TRANSIT.

3. INSTALLATION INSTRUCTIONS

PROPER INSTALLATION IS ESSENTIAL FOR TROUBLE-FREE OPERATION. ANY ALTERATIONS TO THE EQUIPMENT VOIDS THE FRYMASTER WARRANTY.

Before installing the newly arrived equipment, inspect the equipment carefully for visible and concealed damage. See "Shipping Damage Claim Procedure" in Section 2.

The fryer installation area must allow for a 6-inch (15 cm) clearance at both sides and back adjacent to combustible materials; 0 inches for non-combustible materials. A minimum of 24-inches (61 cm) should be provided at the front of the fryer(s) for servicing and proper operation. Air for combustion enters the unit below the cabinet base. **DO NOT BLOCK THE AREA AROUND THE BASE OR UNDER THE FRYERS.**

THE APPLIANCE AREA MUST BE KEPT FREE AND CLEAR OF COMBUSTIBLES.

WARNING DO NOT ATTACH APRON DRAIN BOARD TO A SINGLE FRYER. THE FRYER MAY BECOME UNSTABLE, TIP OVER, AND CAUSE INJURY.

FRYERS EQUIPPED WITH CASTERS

1. Frymaster fryers equipped with casters must be installed in a manner that will allow the fryer drain line to drain properly. See Caster Installation Instruction sheet included with fryer literature package.
2. Adequate means must be provided in order to avoid the splashing of hot liquid without depending on the gas connector and any quick-disconnect device or its associated piping. This can be accomplished by attaching restraining chains/cables to the outside of the front casters and securing the chains/cables to the floor.
3. Installation shall be made with a gas connector that complies with the latest editions of the Standard for Connectors for Movable Gas Appliances ANSI Z21.69 and Addenda, Z21.69, and a quick-disconnect device that complies with the latest edition of the Standard for Quick-Disconnect Devices for Use With Gas Fuel, ANSI Z21.41.

NATIONAL CODE REQUIREMENTS

Frymaster gas fryers are manufactured to use the type gas specified on the rating plate located on the fryer door(s). When installing gas fryers in the UNITED STATES, the installation must conform with the latest edition of the National Fuel Gas Code, ANSI Z223.1. In addition, all local codes must be followed. In CANADA, installation must conform with the latest edition of Standard CANI-B149.1 and .2, "Installation Codes for Gas Burning Appliances & Equipment". Again, all local codes must be complied with.

When installing any type of gas-fired commercial kitchen equipment, Standard No. 96 and Standard 211 of the National Fire Protection Association must be followed implicitly. A copy of the standards may be obtained from the National Fire Protection Association, Battery March Park, Quincy, Massachusetts 02269.

In Australia, this appliance must be installed by an authorized person, in accordance with the manufacturer's instructions, local gas, and electrical regulations, and requirements of AA601, "Installation Requirements for Gas Burning Appliances".

ELECTRICAL GROUNDING INSTRUCTIONS

WARNING

All electrically operated appliances must be electrically grounded in accordance with local codes; or in

the absence of local codes, with the latest edition of the National Electric Code, ANSI/NFPA No. 70, in CANADA, with CSA-C22-1 Canadian Electrical Code Part 1. In the U.S. and Canada, the electrical supply must be 120 VAC, 60 Hz. Check the electric rating plate and wiring diagram located on the inside of the fryer door. In other countries, check the electric rating plate on the inside of the fryer door.

This appliance is equipped with a three-prong 120 volt (230 v. Australia) grounding plug for your protection against shock hazard and must be plugged directly into a properly grounded three-prong receptacle. **DO NOT CUT OR REMOVE THE GROUNDING PRONG FROM THIS PLUG.** This fryer requires electrical power for operation. Turn the gas control valve to the OFF position in case of prolonged power outage. This will prevent the chance of the fryer coming on when unattended. **DO NOT ATTEMPT TO USE THE FRYER DURING POWER OUTAGE.**

GAS CONNECTIONS AND PIPE SIZE

The size of the fryer gas supply pipe is very important. If the pipe is too small, the gas pressure at the burner manifold will be low. This will cause slow recovery and delayed ignition. The incoming gas supply line should be a minimum of 1-1/2". All single MJ45E fryers require a 3/4" connection. Batteries of two and three MJ45E fryers require a 1" connection. **NOTE:** Runs of more than 20 feet and more than 4 fittings or elbows require an increase of one pipe size. For gases with heating values less than 800 BTU's per cubic foot, increase the pipe by one size. For LP gases, the next smaller pipe size may be used. If in doubt about pipe size, consult the local gas company.

Caution:

Before connecting the new pipe to the MJ45E series fryers, the pipe **MUST** be blown out thoroughly to remove all foreign particles. Foreign particles in the burner and controls may cause improper and dangerous operation.

When using thread compound, use very small amounts on male threads only. Use a pipe thread compound that is not affected by the chemical action of LP gases (Loctite PST 56765). **DO NOT** apply compound to the first two threads. This will prevent clogging of the burner orifices and control valve.

Have the installer check all gas plumbing with a soap solution for leaks. **DO NOT** use matches, candles, or other ignition materials.

The fryers and individual shut-off valves must be disconnected from the gas supply piping system during any pressure testing of the gas supply piping at pressures equal to or greater than 1/2 psig (3.45kPa) (13.84inW.C.).

The fryers must be isolated from the gas supply piping system by closing its individual manual shutoff

valve during any pressure testing of the gas supply piping system at test pressures equal to or less than 1/2 psig (3.45 kPa).

FRYERS EQUIPPED WITH FRYMASTER COMPUTERS

This equipment generates and uses radio frequency energy. If it is not installed and used properly in accordance with the manufacturer's instructions, it may cause interference to radio and television reception. It has been tested and found to comply with the limits of a Class B computing device in accordance with the specifications in Subpart J of Part 155 of FCC Rules, which are designed to provide reasonable protection against such interference in a residential installation. However, there is no guarantee that interference will not occur in a particular installation. If this equipment does cause interference to radio or television reception, the user is encouraged to correct the interference by one of the following procedures:

1. Reorient the receiving antenna of the receiver.
2. Relocate the computer with respect to the receiver.
3. Move the computer away from the receiver.
4. Plug the computer into a different outlet so that the computer and receiver are on different branch circuits.

If necessary, the user should consult the dealer or an experienced radio and television technician for additional suggestions.

The user may find the following booklet prepared by the Federal Communications Commission helpful: "How to Identify and Resolve Radio-TV Interference Problems". This booklet is available from the U. S. Government Printing Office, Washington, DC 20402, Stock No. 004-000-00345-4.

AFTER FRYER IS UNDER FRY STATION EXHAUST HOOD

CAUTION:

DO NOT CONNECT FRYER TO GAS SUPPLY BEFORE COMPLETING STEPS 1 THROUGH 4.

1. Test exhaust hood electrical power system as follows:
 - a. Plug fryer electrical cord into any fry station electrical receptacle.
 - b. Press fryer power switch to ON position.
 - c. For fryers with solid-state thermostat control panel, NOTE that the red power and heat indicating lights are lit.
 - d. For fryers with computer or electrical timer control panel, NOTE that the display indicates "CYCL".
 - e. Press fryer power switch to OFF.
 - f. This completes the exhaust hood electrical power system test.

2. To level fryers equipped with legs, screw out the legs approximately one inch. Legs should be adjusted so that the fryer is level and at its proper height under the exhaust hood.
For fryers equipped with casters, there are no built-in leveling devices. The floor where the fryers are installed must be level.
3. Check the serial plate on the fryer door to determine if fryer burner is set up for the proper gas type before connecting the quick disconnect or piping from the building gas supply pipe.
 - a. Minimum incoming gas pressure for NATURAL GAS is 6 in. W.C.(1.61kPa). Maximum incoming gas pressure for NATURAL GAS is 14 in. W.C. (3.48kPa).
 - b. Minimum incoming gas pressure for LP GAS is 11 in. W.C. (2.37kPa). Maximum incoming gas pressure for LP GAS is 14 in. W.C. (2.73kPa).
4. Connect the quick disconnect hose or pipe from the building gas pipe to the fryer quick disconnect fitting under front of fryer or pipe at rear of fryer.
5. Close the fryer drain valve and fill frypot with water and boil-out solution to the OIL-LEVEL line at back of frypot. Light the fryer. REFER TO LIGHTING INSTRUCTIONS page 5 and BOIL-OUT INSTRUCTIONS On page 5.
6. Test all piping for gas leaks. A soap solution should be used for this purpose. Never use a flame.

WARNING IF GAS ODORS ARE DETECTED, THE FRYER GAS SUPPLY MUST BE SHUT OFF AT THE MAIN SHUT-OFF VALVE, AND THE LOCAL GAS COMPANY OR AUTHORIZED SERVICE AGENCY CONTACTED FOR SERVICE.

7. Burner operating gas pressure can be checked at this time. REFER TO CHECK BURNER MANIFOLD PRESSURE in Section 16 of this manual.
 - a. Burner manifold pressure NATURAL GAS MUST BE 3.5 in. W.C. (0.8kPa).
 - b. Burner manifold pressure LP GAS must be 8.25 in. W.C. (2.5kPa).

NOTE: This should be checked by the local gas company or authorized service agent.

8. Check the thermostat knob calibration or computer programmed temperature. REFER TO THERMOSTAT CALIBRATION in Section 7 of this manual.

4. OPERATING INSTRUCTIONS

WARNING

When fryers are in use, fryer restraint chains/cables must be installed in order to prevent the fryer from tipping and splashing hot liquid.

(THESE INSTRUCTIONS APPLY FOR FIRST-TIME USE OF THE FRYER)

BOILING OUT THE FRYPOTS

Clean new frypots as follows before filling with shortening:

1. Before operating the burner, close fryer drain valve, and fill empty frypot with a mixture of cold water and boil-out solution. Fill to the frypot OIL-LEVEL LINE.
2. To light fryer, follow LIGHTING INSTRUCTIONS, this page or LIGHTING INSTRUCTIONS on back of fryer door.
3. For fryers equipped with computer or solid-state controller, set thermostat knob to 200°F (93°C) or program computer for BOIL OPERATION as outlined in PROGRAMMING INSTRUCTIONS IN SECTION 9 of this manual.

For fryers equipped with thermostat, set thermostat knob to 275°F (135°C) and press fryer ON/OFF switch to ON.

4. Simmer the solution for one hour. **Caution:** NEVER leave the fryer unattended during the boil-out procedure. In the event the boil-out solution should foam up and overflow, press the ON/OFF switch to the OFF position to control this condition.
5. After the solution has simmered for one hour, press the ON/OFF switch to OFF and allow the solution to cool.
6. Add two gallons (7.75 liters) of cold water. Drain out the solution and clean the frypot thoroughly.
7. Close the drain valve and fill the frypot with clean water. Rinse the frypot twice and wipe down with a clean, dry towel.

CAUTION

ALL DROPLETS OF WATER MUST BE REMOVED FROM THE FRYPOT BEFORE FILLING WITH SHORTENING.

FILLING WITH SHORTENING

Shortening capacity of the MJ45 Series fryers is 50 lbs. (22.7kg.) for a full pot and 25 lbs. (11.4kg) for each half of a split frypot.

1. Make sure fryer switch is OFF.
2. Close frypot drain valve, remove basket support rack if required.
3. Fill empty frypot to the OIL-LEVEL LINE. When solid shortening is used, it must be thoroughly packed down into the frypot cold zone.

LIGHTING INSTRUCTIONS — MJ45 SERIES FRYER

Frypot MUST be filled before lighting. See BOILING OUT THE FRYPOT, and FILLING WITH SHORTENING this page.

1. Press fryer power ON/OFF switch to OFF position.
2. Turn gas valve knob (located behind fryer door) to OFF position. See Figure 1. Wait five (5) minutes before proceeding.

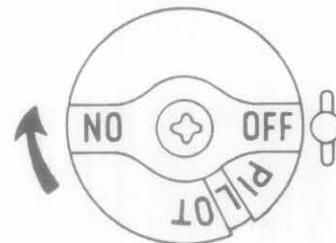

Figure 1
AUTOMATIC VALVE KNOB OFF POSITION

3. Rotate gas valve knob to PILOT position. See Figures 2 and 3

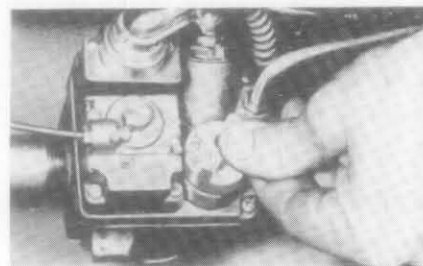

Figure 2
DEPRESSING VALVE KNOB

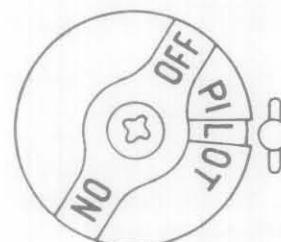

Figure 3
AUTOMATIC VALVE KNOB PILOT POSITION

4. Push knob in, light pilot and continue to hold knob in for approximately 60 seconds after flame appears. Release the knob and pilot should remain lit. See Figure 4. If pilot does not remain lit

when knob is released, wait 5 minutes before attempting to relight.

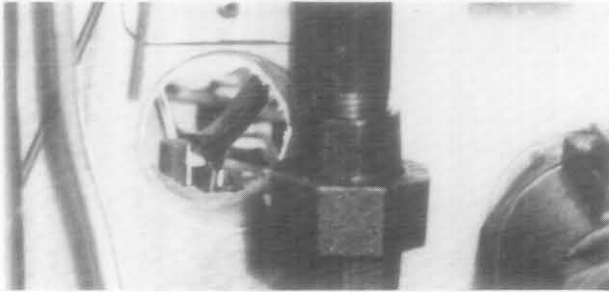

Figure 4
PILOT LIGHT

3. Turn gas valve knob (located behind fryer door) to ON position. See Figure 5.

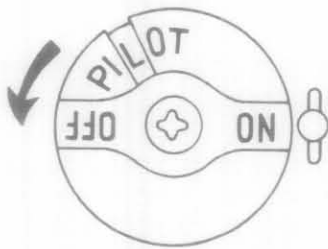

Figure 5
AUTOMATIC VALVE KNOB ON POSITION

4. For fryers equipped with computer or solid-state controller, press fryer power ON/OFF switch to ON and set thermostat knob or program computer for normal cooking temperature. Burners will now operate in a MELT CYCLE MODE until the shortening reaches 180°F (83°C). It will then automatically switch to normal operation. After the shortening has melted and reached frying temperature, thermostat knob calibration or computer programmed temperature can be checked by referring to Section 7 and 9.
5. For fryers equipped with standard thermostat, press ON/OFF switch and MELT switch (if equipped) to ON position and set thermostat knob to normal cooking temperature. The main burner will now light and be controlled by the thermostat or melt cycle timer. The melt cycle feature must be turned off manually after shortening has melted.
6. If burner fails to light, press ON/OFF Switch OFF and wait 60 seconds and repeat above steps.

ACCESSING FRYERS FOR SERVICING

WARNING

Moving a fryer filled with hot shortening may cause splattering of the hot shortening. Extreme care must be exercised. It is recommended that the operator or servicer follow the draining instructions on Page 7 of this manual before attempting to relocate the fryer.

1. Disconnect quick-disconnect hose and power cord.
2. Remove restraining devices typically applied to the bottom or back of fryer.
3. Relocate fryer so that access can be obtained to perform necessary maintenance.
4. After servicing has been completed, reconnect quick-disconnect hose and power cord; and attach restraining devices.

SHUTTING FRYER(S) OFF FOR SHORT PERIODS

1. Press fryer power switch to OFF position.
2. Put frypot cover(s) in place.

SHUTTING FRYER(S) OFF WHEN CLOSING STORE

1. Press fryer power switch to OFF position.
2. Turn gas valve knob clockwise to PILOT.
3. Depress knob and rotate slightly clockwise.
4. Release and continue rotating knob to OFF. See Figure 1.

5. VENTILATION AND CLEARANCE

One of the important considerations of efficient fryer operation is ventilation. The fryer must be installed so that products of combustion are removed efficiently, and the kitchen ventilation system does not produce drafts that interfere with proper burner operation. The fryer flue opening must not be placed close to the intake of the exhaust fan.

The fryer must never have its flue extended in a "chimney" fashion. An extended flue will change the combustion characteristics of the fryer causing it to be slow to recover, and frequently causing delayed ignition.

To provide air flow necessary for good combustion and burner operation, the areas surrounding the fryer front(s), side(s), and rear must be kept clear and unobstructed.

The fryer(s) must be installed in an area with adequate air supply and ventilation.

Many operators do not realize that the finest ventilation system will break down when it is not maintained properly.

The duct system, the hood, and the filter bank must be cleaned on a regular basis and kept free of grease.

Adequate distances must be maintained from the flue outlet of the fryer to the lower edge of the filter bank. Filters should be installed at an angle of 45°, and a drip tray should be located beneath the lowest edge of the filter. For U.S. Installation, NFPA Standard No. 96 states that, "A minimum distance of 18 in. (450mm) should be maintained between the flue outlet and the lower edge of the grease filter". We recommend that the MINIMUM DISTANCE BE 24 in. (600mm) FROM THE FLUE OUTLET TO THE BOTTOM EDGE OF THE FILTER WHEN THE APPLIANCE CONSUMES MORE THAN 120,000 BTU PER HOUR. Information on construction and installation of ventilating hoods can be found in the NFPA Standard above. A copy of this standard may be obtained from the National Fire Protection Association, Battery March Park, Quincy, Mass. 02269.

6. DRAINING AND FILTERING INSTRUCTIONS

WARNING

Draining and filtering of shortening must be accomplished with care to avoid the possibility of a serious burn caused from careless handling.

FILTERING

If you are using a filter other than the Frymaster Filter Magic, consult the filter manufacturer's operation instructions for recommended filtering procedure. Instructions for using the Filter Magic II are included in the Filtration Section of this manual.

The following procedure is recommended to drain and filter your shortening when a filter machine is not available.

1. Press the fryer power switch to OFF. Screw the drain pipe provided with the fryer into the drain valve. Make sure the drain pipe is firmly screwed into the drain valve, and that the curved end is pointing downward. (Figure 6.)
2. Position a stock pot or other suitable container under the drain pipe. The stock pot or other container must be of sufficient design to withstand the hot shortening and must be able to hold liquids. Frymaster recommends that a Frymaster filter cone holder and filter cone be used when a filter machine is not available. If you are using the Frymaster filter cone holder and cone, be sure that the cone holder rests securely on the stock pot or other container.



Figure 6

3. Open the drain valve slowly to avoid splattering. If splattering occurs, exercise extreme caution.
4. If the drain valve becomes clogged with food particles, you may wish to use the FRYER'S FRIEND (poker like tool). This tool must be used from INSIDE the frypot ONLY (Figure 7). Carefully grip the tool as far as possible away from the shortening in the frypot. DO NOT hammer on the drain valve as damage to the ball inside will cause it to leak. DO NOT insert into front of drain valve in an attempt to unclog the valve; hot shortening will rush out creating the potential for injury.
5. The drained shortening should be allowed to cool to 100°F (38°C) or lower before transporting the container and removing drain pipe. Shortening temperature of 140°F (60°C) or higher will result in severe burns.

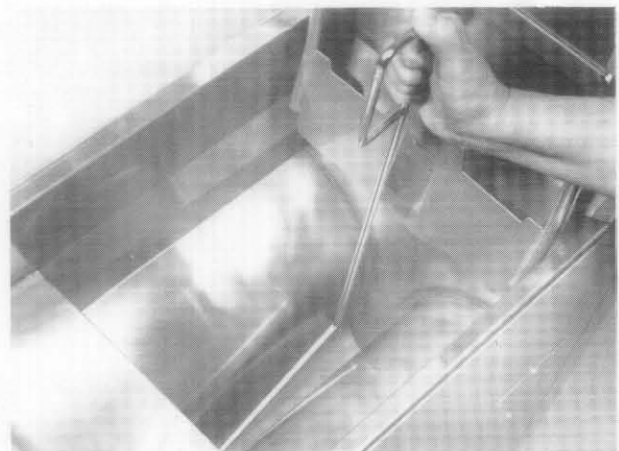

Figure 7

CAUTION

SEE THE FILTRATION SECTION OF THIS MANUAL BEFORE TRANSPORTING HOT SHORTENING TO DISPOSAL AREA.

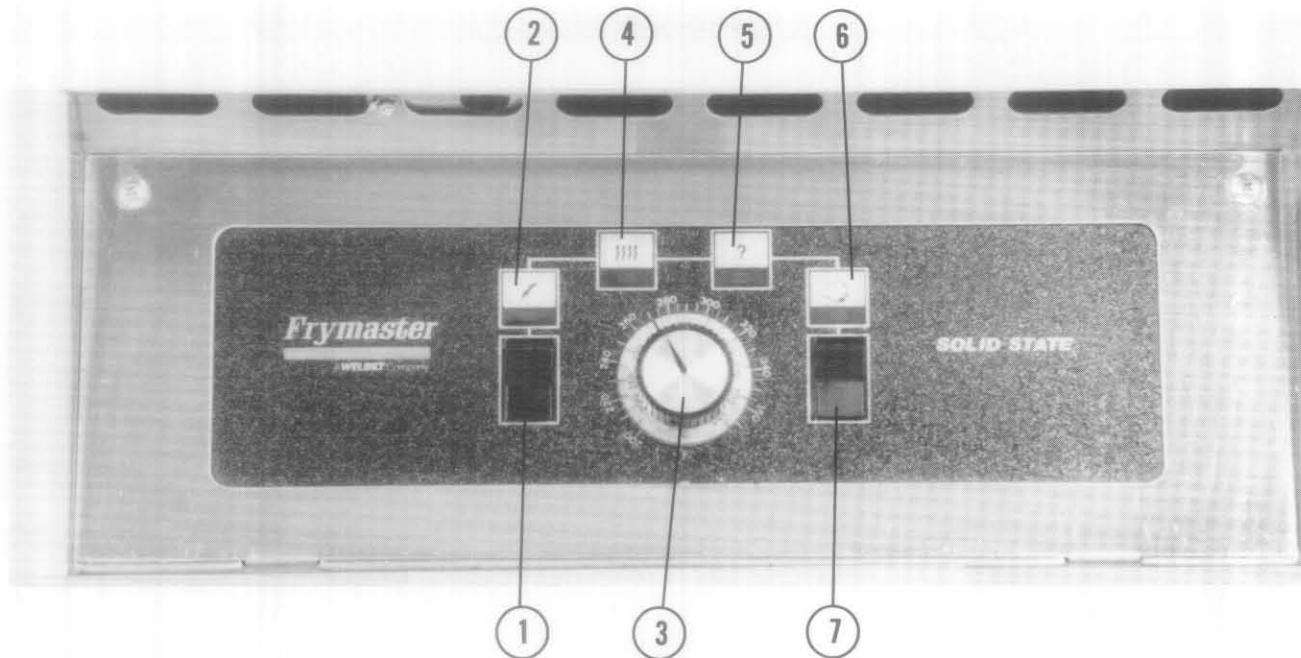

Figure 8

7. SOLID-STATE THERMOSTAT CONTROL PANEL (SINGLE CONTROLLER SHOWN) (Refer to Numbers Above)

Item No.

1. Power Supply Switch — controls power supply.
 2. Power On Light — indicates when electrical power is on.
 3. Temperature Control Knob — sets desired frying temperature.
 4. Heating Light — indicates burner is on.
 5. Trouble Light — indicates solid-state ignition system lockout. The controller must be reset. To reset, turn power switch to OFF for 30 seconds, then ON.
 6. Melt Cycle Light — indicates unit is operating in Melt Cycle Mode.
 7. Melt Cycle Switch — controls melt cycle operation.
- WARNING**
FRYER MUST BE FILLED WITH OIL, SHORTENING, OR WATER BEFORE TURNING ON CONTROLLER.
- THERMOSTAT CALIBRATION — SOLID-STATE THERMOSTAT CONTROLLER**
1. Insert a good grade thermometer or pyrometer probe into the shortening near the fryer temperature sensing probe.
 2. Turn thermostat knob to frying temperature.
 3. Let burner cycle on and off automatically three times in order for the shortening temperature to be uniform. Stir, if necessary, to get all shortening in bottom of frypot melted.
 4. When the main burner turns on for the fourth time, the pyrometer reading should be within 5°F ($\pm 2^{\circ}\text{C}$) of the thermostat knob setting. If it is not, calibrate as follows:
 - a. Loosen set screw in thermostat control knob until outer shell of knob will rotate on insert inside knob.
 - b. Rotate outer shell of knob until index line on knob aligns with marking that corresponds to thermometer or pyrometer reading.
 - c. Hold knob and tighten set screw.
 - d. Recheck the thermometer or pyrometer reading and the thermostat knob setting the next time the burner comes on.
 - e. Repeat steps 4a. through 4d. until thermometer or pyrometer reading and knob setting agree within 5°F ($\pm 2^{\circ}\text{C}$).
 - f. If calibration cannot be obtained for any reason, call Factory Authorized Service Center.
 5. Remove thermometer or pyrometer probe.

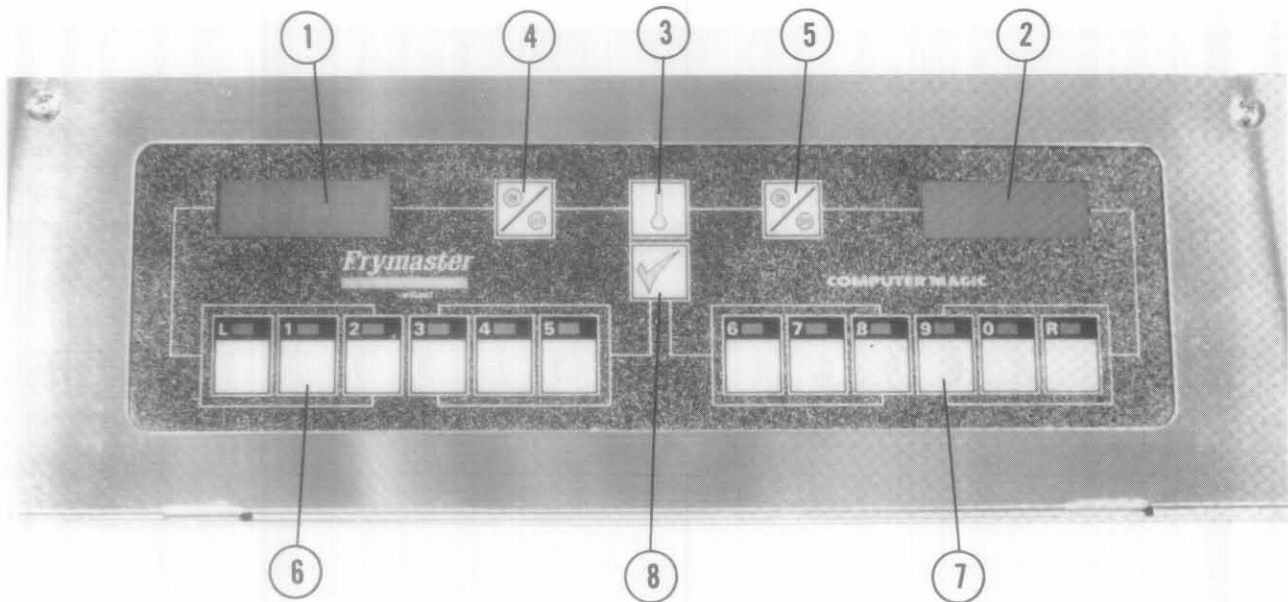

Figure 9

8. COMPUTER MAGIC III CONTROL PANEL — OPERATING INSTRUCTIONS (Refer to Numbers Above)

Item No.

1. Lighted Display — left side display of various functions and operations.
2. Lighted Display — right side display of various functions and operations.
3. Storage and Temperature Check Switch — locks program in computer and/or displays frypot temperature when depressed.
4. ON/OFF Switch — controls on/off for left side of dual frypot computer.*
5. ON/OFF Switch — controls on/off for right side of dual frypot computer.*
- 6/7. Product and Coding Switches — enter code for access to computer and programming functions.
8. Programming Switch — used when reprogramming the computer memory.

*On single frypot computer, either left or right switch will turn on/off.

Complies with the limits of a class B computing device pursuant to sub-part J of part 15 of FCC Rules.

WARNING FRYER MUST BE FILLED WITH OIL, SHORTENING, OR WATER BEFORE TURNING ON COMPUTER.

OPERATING INSTRUCTIONS

- A. Turn the computer on by pressing the ON/OFF SWITCH, Item 4 or 5.

1. This will turn computer (fryer) on. One of the following will be displayed:
 - a. "CYCL" indicating that the burner is operating in the melt cycle mode. Fryer will remain in the melt cycle mode until it reaches 180°F (82°C) or canceled manually. (See B next page.)
 - b. "Hi" indicating that the pot temperature is 16°F (6°) higher than the set point.
 - c. "Lo" indicating that the pot temperature is 16°F (6°C) lower than the set point.
 - d. "- - -" indicating that the fryer temperature is in the cooking range. **NOTE:** For best results, cooking product should not be attempted unless display indicates "- - -".
 - e. "Help" indicating that there has been a heating problem.
 - f. "Hot" indicating that the pot temperature is in excess of 385°F (196°C).
 - g. "Prob" indicating that the computer has detected a problem in the temperature measuring circuits, including probe.

NOTE: "." decimal point between digits 1 and 2 in either display area indicates that the burner is on.

B. Melt Cycle Cancel Feature. **Caution:** Melt cycle should not be canceled if solid shortening is used.

1. The computer will display "CYCL" during melt-cycle operation. To cancel melt cycle, depress "R" Switch. "CYCL" will be replaced by "LO". The decimal point between digits 1 and 2 will illuminate indicating that the burners are on.

C. Cook-cycle operation is initiated by pressing product switch:

1. The basket lift (on fryers so equipped) will lower the product into the shortening.
2. The display will indicate the previously programmed cook time and begin countdown.
3. If shake time is programmed, the operator will be notified of the need to shake the product "X" seconds after the cook cycle has begun (X = amount of time programmed). An alarm will sound, and the display will read "SH_". The blank will be the switch number. If no shake time has been programmed, "SH-" will not appear during the cook cycle. The alarm is self cancelable.
4. At the end of cooking cycle, an audio alarm will sound, "COOC" will be displayed, and the associated product switch indicator will flash. To cancel the cook alarm, press the appropriate switch.

5. At this time, the hold time will be displayed (if programmed greater than 0), and countdown to zero at which time an alarm and "Hd-" will be displayed. The blank will be the switch number. Hold alarm is canceled by pushing PROGRAMMING CHECK SWITCH, Item 8. If display is in use, hold time will count down invisibly until display is free.

CHECKING TEMPERATURE

- A. Check the shortening temperature at any time by pressing STORAGE AND TEMPERATURE CHECK SWITCH, Item 3, once. Check the set point by pressing STORAGE AND TEMPERATURE CHECK SWITCH, Item 3, twice.
- B. During the idle periods when the fryer is on but not in use, "- - -" should appear in both displays, Item 1 and 2. If not, check actual temperature and set point.
- C. Should you suspect the probe is defective, check shortening temperature with a thermometer to verify that computer readout is reasonably close to your measured reading.

NOTE: The electronic circuitry can be affected adversely by current fluctuations and electrical storms. Should it not function or program properly for no apparent reason, the computer should be reset by unplugging fryer and plugging it back in. This could eliminate a service call.

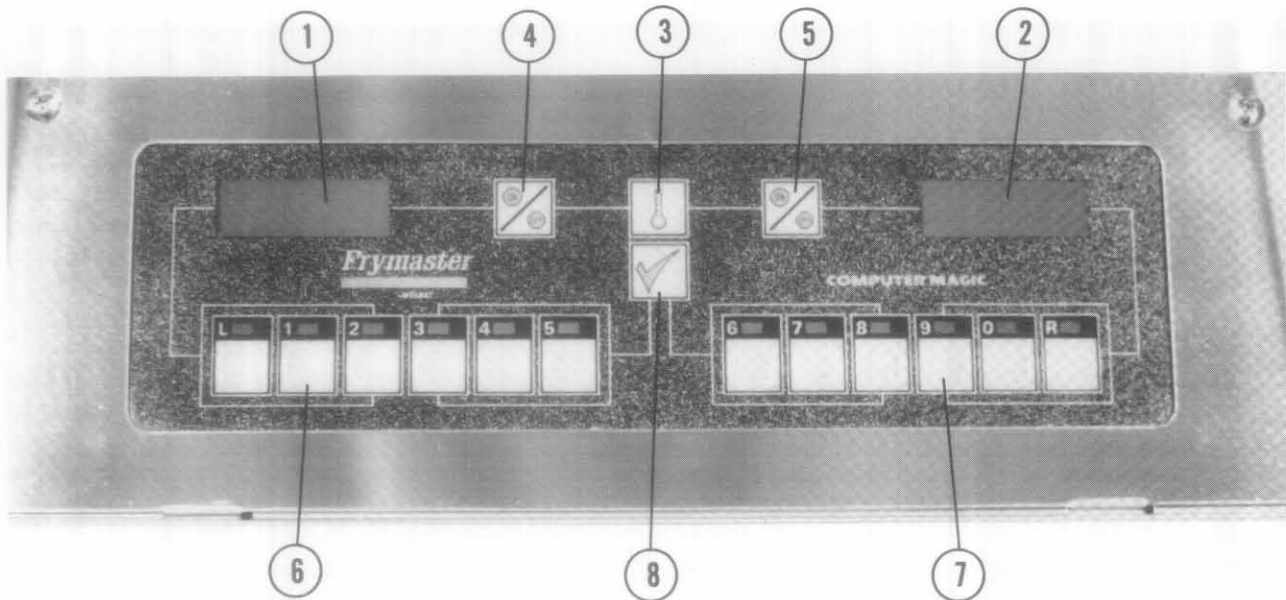

Figure 10

9. COMPUTER MAGIC III CONTROL PANEL— PROGRAMMING INSTRUCTIONS (Refer to Numbers Above)

Item No.

1. Lighted Display — left side display of various functions and operations.
2. Lighted Display — right side display of various functions and operations.
3. Storage Switch — locks program in computer.
4. ON/OFF Switch — controls power supply for left side of dual computer.*
5. ON/OFF Switch — controls power supply for right side of dual computer.*
- 6/7. Product and Coding Switches — enter code for access to computer and programming functions.
8. Programming Switch — used when reprogramming the computer memory.

*On single frypot computer, either left or right switch will control power.

WARNING FRYER MUST BE FILLED WITH OIL, SHORTENING, OR WATER BEFORE TURNING ON COMPUTER.

PROGRAMMING INSTRUCTIONS FOR THE FRYMASTER COMPUTER. PLEASE READ INSTRUCTIONS BEFORE PROGRAMMING COMPUTER

1. Press ON/OFF SWITCH, Item 4 or 5.

2. To enter program mode, press green PROGRAMMING SWITCH, Item 8. "CODE" will appear in left display. If you have pressed this switch in error and do not wish to program, simply press PROGRAMMING SWITCH, Item 8, again. NOTE: Computer will flash "BUSY" if cooking is in progress.
3. Enter Code Number: Press 1,6,5,0 in that sequence on Item 6 and 7. Your program will not be accepted unless these numbers are entered. This prevents an unauthorized person from changing your present instructions.
4. "SP-r" (SET POINT) will appear in the left display, Item 1; this is for setting temperature; temperature previously selected will be displayed in the right display, Item 2. Enter temperature desired. Press PROGRAMMING SWITCH, Item 8, to lock in temperature setting. If you do not need to change the settings, press PROGRAMMING SWITCH, Item 8.
5. "SELP" (SELECT PRODUCT) appears in Item 1. Press the product button to be programmed.
6. "SENS" appears in Item 1. The sensitivity number previously selected will be displayed in Item 2. Enter the new desired sensitivity number. Press Programming Switch, Item 8, to lock in sensitivity setting.

NOTE: SENS — Sensitivity is a built-in feature that causes the computer to adjust cooking time to compensate for the drop in shortening tem-

perature when a basket of product is placed into the fryer. Different food products will vary in density, basket load size, and initial temperature. Food products will also vary in how well cooked a product is required to be. A proper sensitivity setting for each product will assure a high-quality product each time. For example: four ounces of french fries can be programmed to be cooked to the same quality as two and one-half pounds. Some experimenting with the range of 1 to 9 may be required to obtain the desired quality to meet your specifications.

7. "COOC" is now displayed in Item 1. If a cooking time has been entered in the program prior to this programming, it will appear in Item 2. If that time is correct, press PROGRAMMING SWITCH, Item 8. If you wish to change that time, enter the numbers. The new time will be displayed in Item 2. Press PROGRAMMING SWITCH, Item 8.
8. "SH-" is now displayed in Item 1. If your product requires shaking during the cooking process, set the time by pressing the number of minutes to cook before shaking. This number will appear in the right display, Item 2.
Example: Total Cook Time 3:00 minutes
Shake After Cooking 1:00 minute
9. Set the desired shake time. At the end of the set time, a beeper will sound, and the product button will flash for 3 seconds. If none is required, set the time at "0" and press PROGRAMMING SWITCH, Item 8.
10. "HD-" will appear in Item 1. Set the time you require for holding the cooked product, 13 seconds to 60 minutes. Press PROGRAMMING SWITCH, Item 8. If you do not wish to use the HOLD time, enter "0" and press PROGRAMMING SWITCH, Item 8. "SELP" will again display in Item 1. If more products are to be programmed, return to Step 5 and follow all instructions to this point.

ADDITIONAL HOLD TIME INSTRUCTIONS

Forcing hold timer to another product button: In the event the same product is being cooked in more than one basket, any product button can be programmed to use the hold timer normally used with a different product button. Example: Program button "3" for 7:00 minutes hold time. Then when programming button "R" for hold time, press address 4. Both "3" and "R" will then use the same hold time of 7:00 minutes. See below for button numbers and their assigned address numbers. Any other button can be programmed to use the same hold time.

BUTTON	L	1	2	3	4	5	6	7	8	9	0	R	
ADDRESS		1	2	3	4	5	6	7	8	9	10	11	12

11. When you complete your program, lock in the program by pressing STORAGE AND TEMPERATURE CHECK SWITCH, Item 3.

BOIL FEATURE

1. Before switching the fryer(s) ON, close the frypot drain valve(s): fill empty frypot with mixture of cold water and FRYMASTER FRYER 'N' GRIDDLE cleaner. Follow instructions when mixing.
2. To program computer for Boil Feature, press ON/OFF SWITCH, Item 4 or 5.
3. Press PROGRAMMING SWITCH, Item 8. "CODE" will appear in the left display.
4. Enter Code Number: Press 1,6,5,3 in that sequence. The right display will read BOIL. The temperature is automatically set for a temperature of 195°F (91°C). The fryer will attain this proper boil temperature and remain there until the OFF switch, Items 4 of 5 is pressed which cancels the boil-out mode. In high-altitude locations, the fryer must be monitored constantly for over-boil conditions. If over-boil conditions occur, turn off fryer immediately, allow to cool, and re-enter boil-out mode to continue the boil-out operation.

FRYER RECOVERY TIME CHECK

1. The computer automatically checks the recovery time each time the pot temperature drops below 250°F (121°C). To check recovery time, press PROGRAMMING SWITCH, Item 8. "CODE" will appear in the left display, Item 1.
2. Enter Code Number: Press 1,6,5,2 in that sequence on Items 6 and 7. The recovery time will appear in both displays, Item 1 and Item 2 for five seconds.

TEMPERATURE SELECTION MODE — FAHRENHEIT TO CELSIUS

1. To change the computer temperature from Fahrenheit to Celsius or Celsius to Fahrenheit, Press ON/OFF SWITCH, Item 4 or 5.
2. Press the PROGRAM CHECK SWITCH, Item 8. "CODE" will appear in left display, Item 1.
3. Enter Code Number 1,6,5,8 in that sequence on Items 6 and 7. The computer will automatically toggle the temperature from Fahrenheit to Celsius or Celsius to Fahrenheit.

4. Press the TEMPERATURE CHECK SWITCH, Item 3 to display the temperature in the newly selected mode.

CONSTANT OIL-TEMPERATURE-DISPLAY MODE

1. The cooking oil temperature will be displayed constantly at all times. To program constant temperature display, press ON/OFF Switch, Item 4 or 5.

2. Press the PROGRAM CHECK SWITCH, Item 8. "CODE" will appear in left display, Item 1.

3. Enter Code 1, 6, 5, L in that sequence on Items 6 and 7. The COMPUTER DISPLAY, Item 2, will display oil temperature constantly.

4. To remove the constant oil-temperature display, repeat step 2 and 3.

NOTE: During product cooking process, the cooking time will not be displayed, but timing is taking place.

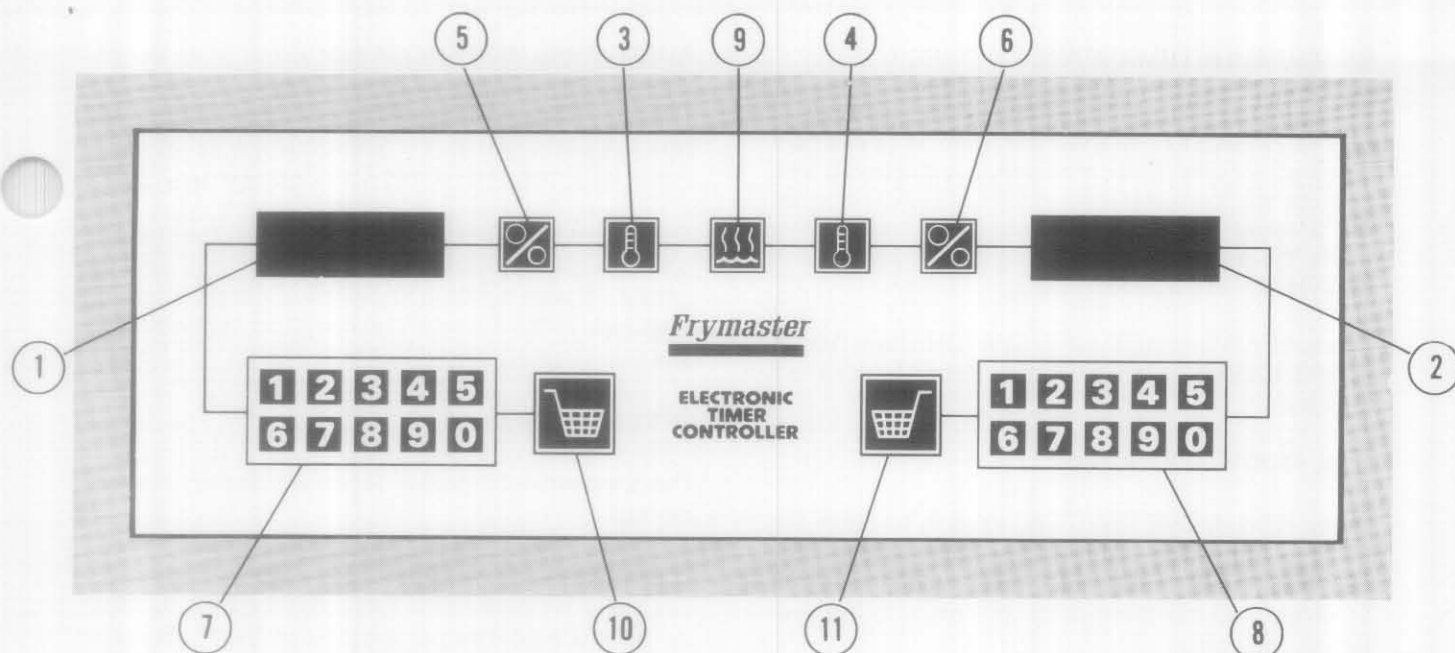

Figure 11

10. TIMER CONTROL PANEL (Refer to Numbers Above)

Item No.

1. Lighted Display — left side display of various functions and operations.
2. Lighted Display — right side display of various functions and operations.
3. Temperature Check Switch — controls left side of split pot. Press once for set point. Press again to return to cook time. (Full pot will display in Item 2.)
4. Temperature Check Switch — controls right side of split pot. Press once for set point. Press again to return to cook time. (Full pot will display in Item 2.)
5. On/Off Switch — controls power supply.
6. On/Off Switch — controls power supply.
7. Cook Time and Temperature Set Switches — controls left side.
8. Cook Time and Temperature Set Switches — controls right side.
9. Boil Mode Switch — controls boil mode.
10. Left Basket Lift Switch — controls left basket lift and cancels alarm.
11. Right Basket Lift Switch — controls right basket lift and cancels alarm.

WARNING FRYER MUST BE FILLED WITH OIL, SHORTENING, OR WATER BEFORE TURNING ON TIMER.

ELECTRONIC TIMER CONTROLLER USER INSTRUCTIONS

TURNING THE UNIT ON

Press ON/OFF SWITCH, either Item 5 or 6.

ADJUSTING THE TEMPERATURE

Press TEMPERATURE CHECK SWITCH, Item 3 or 4. Current set point is displayed in Item 2. To change set point, enter new temperature with numbered keys, Item 8. Press TEMPERATURE CHECK SWITCH, Item 3 or 4, to lock in set point. If you do not need to change setting, return to cook time by pressing Item 3 or 4.

ADJUSTING THE TIMERS

The Electronic Timer Controller is always ready to time the cook operation for the time displayed in Items 1 and 2. You may change the time using the following procedure:

Left Basket Timer — enter new time with number keys, Item 7.

Right Basket Timer — enter new time with number keys, Item 8.

COOKING INSTRUCTIONS

Press LEFT BASKET LIFT SWITCH, Item 10 or RIGHT BASKET LIFT SWITCH, Item 11 to initiate a timed cook cycle. The corresponding displayed time now counts down. At timeout, the basket lift removes the product from the shortening. An audio alarm alerts the operator that cooking is completed, and the display area shows COOC.

Press LEFT BASKET LIFT SWITCH, Item 10, or RIGHT BASKET LIFT SWITCH, Item 11, to cancel the alarm.

BOIL MODE OPERATION

Press BOIL MODE SWITCH, Item 9, to reset the timer to 195°F (91°C). The fryer will now maintain 195°F (91°C) until either On/Off switch is pressed, at which time the thermostat will return to the previously set value.

MELT CYCLE OPERATION

The fryer automatically goes into melt cycle if shortening temperature is under 180°F (82°C). To override melt cycle, press RIGHT BASKET LIFT SWITCH, Item 11.

ADDITIONAL INSTRUCTIONS

The controller automatically selects Fahrenheit/Celsius temperature values. Temperature values less than 190°F are considered Celsius values.

The Electronic Timer Controller stores the current time and temperature settings when the unit is turned off with the On/Off switches, Items 5 and 6. However, in the event of power failure, recheck time and temperature setting.

FRYER ALARMS

The Electronic Controller Timer will display the following:

Heat Failure Alarm "HELP": displayed continuously indicates that there has been a heating failure. High Temperature Alarm "Hot": displays if the frypot temperature is above 385°F (196°C). Defective Probe Alarm "Prob": indicates the probe is defective.

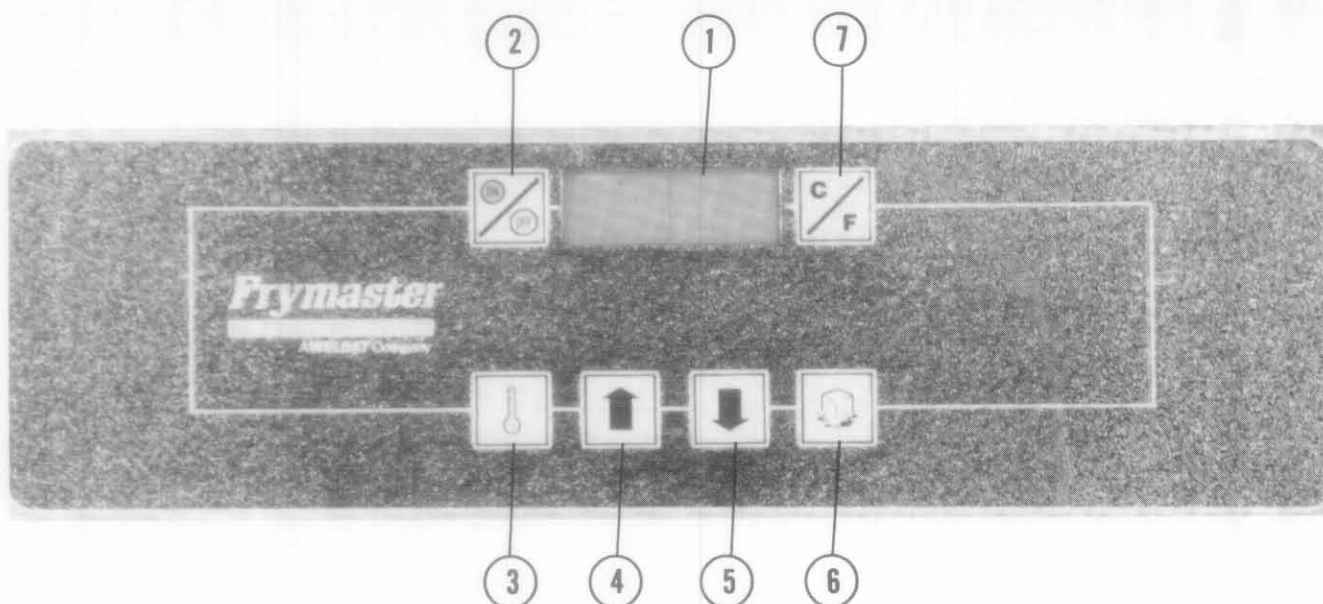

Figure 12

11. DIGITAL SOLID-STATE CONTROLLER (Refer to Numbers Above)

Item No.

1. Lighted Display — Display of various functions and operations.
2. On/Off Switch — Controls power supply.
3. Temperature/Set-Point Display Switch — Selects shortening temperature or set-point temperature.
4. Up Arrow Switch — Raises set-point temperature.
5. Down Arrow Switch — Lowers set-point temperature.
6. Melt-Cycle Switch — Cancels melt-cycle mode.
7. C/F Switch — Selects temperature display in celsius or fahrenheit.

This device complies with the limits of Class B computing device pursuant to Sub-part J of Part 15 of FCC Rules.

WARNING FRYER MUST BE FILLED WITH OIL, SHORTENING, OR WATER BEFORE TURNING ON CONTROLLER.

OPERATING INSTRUCTIONS

- A. Turn controller on by pressing ON/OFF Switch, Item 2.

1. The controller software version number will display for four (4) seconds then set-point temperature will display constantly on U. S. and all other domestic fryers. To view actual shortening temperature, press the Temperature Switch, Item 3. On export fryers, the actual shortening temperature will display constantly. To view the set-point temperature, press the Temperature Switch, Item 3.
2. The controller automatically enters melt cycle mode if shortening temperature is below 180°F (82°C).
3. To cancel melt-cycle mode, press the Melt Switch, Item 6. **Caution:** Melt cycle should not be canceled if solid shortening is used.
4. When the shortening temperature reaches 180°F (82°C), the controller will exit the melt-cycle mode and seek set-point temperature.

- B. To set the set-point temperature up or down, press the Up Arrow Switch, Item 4 to raise the set-point temperature, and the Down Arrow Switch, Item 5, to lower the set-point temperature.

1. The display will change at the rate of approximately one degree per second.
2. After a change of about 12 degrees, the display will change to a faster rate allowing large changes in set-point temperature to be made quickly.

C. To change from fahrenheit to celsius display, press the C/F Switch, Item 7.

1. Display will change from "XXX^oF" to "XXX^oC".

2. Display will change back to "XXX^oF" by pressing the C/F Switch, Item 7, again.

D. When the controller has reached the set-point temperature, the heat indicator decimal point will go out, indicating the fryer is ready for cooking process.

NOTE: The decimal point appearing between the first two numbers of the display indicates the heating source is on.

12. TROUBLESHOOTING GUIDE — FRYER EQUIPPED WITH COMPUTER MAGIC III, BASKET LIFT TIMER, DIGITAL CONTROLLER

Note: Digital Controller Does Not Have An Audible Alarm.

WARNING

Inspection, testing and repair of electrical equipment should be performed only by qualified service personnel. The unit should be unplugged when servicing, except when electrical tests are required.

DANGER: Use extreme care during electrical circuit tests. Live circuits will be exposed.

NOTE: This guide does not include every possible problem and the cause. However, careful observation of all malfunction indications and logical troubleshooting will help in correcting the problem in a more expedient manner.

NOTE: See SERVICE PROCEDURES to replace fryer components.

PROBLEM	PROBABLE CAUSE	CORRECTIVE ACTION
POWER SWITCH ON, HEAT INDICATOR DECIMAL CYCLES ON AND OFF, BURNER OFF, PILOT LIT.	A. Gas valve knob set at "Pilot" position.	A. Rotate gas valve knob to ON position.
	B. Gas valve defective.	B. Replace gas valve.
	C. Loose wire connections on gas valve.	C. Repair loose connections on gas valve.
	D. Defective gas valve relay on interface board.	D. Replace relay.
POWER SWITCH ON, DISPLAY SHOWS "HELP", PILOT OUT, BURNER OFF. (FRYER(S) PRIOR TO SERIES AH.)	A. Pilot light out.	A. Relight pilot light.
	B. Fryer manual gas shut-off valve closed.	B. Open shut-off valve.
	C. Gas quick-disconnect hose fitting not fully connected.	C. Check and ensure quick-disconnect fitting snaps onto fitting firmly.
	D. Defective hi-limit thermostat.	D. Replace hi-limit thermostat.
	E. Defective thermopile.	E. Replace thermopile.
POWER SWITCH ON, DISPLAY SHOWS "HOT", BURNER OFF, PILOT LIT.	A. Shortening temperature above 385°F (196°C).	A. Turn fryer off, allow to cool below 375°F (190°C) and restart.
	B. Computer programmed above 370°F (188°C).	B. Reprogram to desired cooking temperature below 370°F (188°C).
	C. Computer defective.	C. Test computer with Frymaster MTB-310A tester. Replace if found to be defective.
POWER SWITCH ON, DISPLAY SHOWS "HOT", ALARM SOUNDING, BURNER OFF.	A. Shortening temperature above 385°F (196°C).	A. Turn fryer off, allow to cool below 375°F (190°C) and restart.
	B. Computer programmed above 370°F (188°C).	B. Reprogram to desired cooking temperature below 370°F (188°C).
	C. Shorted temperature sensing probe.	C. Check continuity or resistance of probe circuit including short to ground. Replace probe if found defective.

PROBLEM	PROBABLE CAUSE	CORRECTIVE ACTION
POWER SWITCH ON, DISPLAY SHOWS "PROB", BURNER OFF.	A. Defective temperature sensing probe.	A. Check continuity or resistance of probe circuit including short to ground. Replace probe if found defective.
	B. Loose pin connections at 12-pin plug on interface board.	B. Repair loose connections at 12-pin plug.
	C. Loose pin connections in 15-pin plugs from computer to interface board.	C. Repair loose connections in 15-pin plugs.
POWER SWITCH ON, NO DISPLAY, BURNER OFF.	A. No power to fryer.	A. Check power supply cord and wall circuit breaker.
	B. No power to computer/controller, 12V LED on interface board not on.	B. Replace 12-volt transformer.
FRYER DOES NOT GO INTO MELT CYCLE, DISPLAY SHOWS "HELP".	A. Defective computer/controller.	A. Swap computer/controller with another fryer or test with Frymaster MTB-310A tester. Replace if found defective.
FRYER DOES NOT COME OUT OF MELT CYCLE, DISPLAY SHOWS "HOT"; INDICATOR DECIMAL CYCLES ON AND OFF WITH BURNER ON CONTINUOUSLY.	A. Defective computer/controller.	A. Swap computer/controller with another fryer or test with Frymaster MTB-310A tester. Replace if found defective.
	B. Gas valve relay on interface board stuck closed.	B. Replace relay.
	C. Diaphragm in gas valve ruptured.	C. Replace gas valve.
PILOT LIGHT REMAINS LIT AS LONG AS GAS VALVE KNOB IS PUSHED IN, GOES OUT WHEN KNOB IS RELEASED.	A. Defective thermopile.	A. Replace thermopile.
	B. Pilot flame too weak.	B. Adjust pilot light pressure or clean pilot orifice.
	C. Defective hi-limit thermostat.	C. Replace hi-limit thermostat.
	D. Defective pilot magnet in gas valve.	D. Replace gas valve.
	E. Defective hi-limit wire adapter.	E. Replace wire adapter.
POWER SWITCH ON, DISPLAY SHOWS "HELP", PILOT LIT, BURNER ON.	A. Defective pilot pressure switch (fryers prior to Series Code AH).	A. Replace pilot pressure switch.
BURNER HAS DELAYED IGNITION (ONE TO FIVE SECONDS).	A. Burner deflector(s) out of alignment.	A. Align deflector(s) to proper alignment. (See Alignment & Adjustment of Burner Ceramic Targets and Deflector Assemblies.)
	B. Pilot flame misdirected away from first 2 burner orifices.	B. Reposition pilot flame directly between first 2 burner orifices.
	C. Pilot bracket bent.	C. Replace or straighten pilot bracket.
	D. Draft in combustion chamber.	D. Eliminate kitchen drafts.

PROBLEM	PROBABLE CAUSE	CORRECTIVE ACTION
(Continued)	E. Pilot flame weak.	E. Raise pilot pressure or clean pilot orifice.
	F. Burner deflector target(s) broken or missing.	F. Replace burner target(s) and align.
	G. Fryer incoming gas pressure too low.	G. Have local gas company raise pressure to proper pressure.
	H. Fryer burner manifold pressure too low.	H. Use a manometer and raise manifold pressure to proper pressure.
	I. Fryer gas line too small.	I. Replace with proper size (see Section 3).
	J. One or more burner orifices clogged.	J. Clean orifices with proper orifice drill size — No. 1.45 mm Natural Gas, No. 0.86 mm L.P. Gas.
	K. Rear deflector target out of alignment or missing.	K. Align target or replace (see Alignment & Adjustment of Burner Ceramic Target and Deflector Assemblies).
POWER SWITCH ON, DISPLAY SHOWS "HELP", PILOT LIT, BURNER OFF.	A. Frypot drain valve open. (Filter Magic fryers only.)	A. Check drain valve handle position.
	B. Defective drain valve switch. FILTER MAGIC FRYERS ONLY	B. Replace drain valve switch.
FLAME VISIBLE ABOVE FLUE OPENING AND BURNER EXCESSIVELY NOISY.	A. Burner gas pressure too high.	A. Use a manometer and adjust burner manifold pressure to proper pressure — 3.5 in. W.C. (0.86kPa) Natural Gas, 8.25 in. W.C. (2.05kPa) L.P.
	B. Gas valve vent tube clogged.	B. Clean and blow out vent tube.
	C. Gas valve regulator defective.	C. Replace gas valve and adjust to proper pressure.
FLAME ROLLS OUT UNDER FRYER.	A. Flue collapsed or obstructed.	A. Replace flue or remove obstruction.
	B. Store air improperly balanced.	B. Balance store air.
	C. Burner gas pressure too high.	C. Use a manometer and adjust burner manifold pressure to proper pressure — 3.5 in. W.C. (0.86kPa) Nat. Gas, 8.25 in. W.C. (2.05 kPa) L.P. Gas.

FOR OTHER BURNER RELATED MALFUNCTIONS, SEE TROUBLESHOOTING GUIDE — FRYERS EQUIPPED WITH STANDARD THERMOSTAT.

13. TROUBLESHOOTING — FRYER WITH SOLID-STATE CONTROLLER AND THERMOSTAT KNOB

WARNING

Inspection, testing and repair of electrical equipment should be performed only by qualified service personnel. The units should be unplugged when servicing, except when electrical tests are required.

DANGER: Use extreme care during electrical circuit tests. Live circuits will be exposed.

NOTE: This guide does not include every possible problem and the cause. However, careful observation of all malfunction indications and logical troubleshooting will help in correcting the problem in a more expedient manner.

NOTE: See SERVICE PROCEDURES to replace fryer components.

PROBLEM	PROBABLE CAUSE	CORRECTIVE ACTION
POWER SWITCH ON, POWER LIGHT ON, HEAT & MELT LIGHTS ON, PILOT LIT, BURNER OFF.	A. Gas valve knob set at PILOT position.	A. Rotate gas valve knob to ON position.
	B. Gas valve defective.	B. Replace gas valve.
	C. Frypot drain valve handle loose or not in position (FILTER MAGIC FRYERS ONLY).	C. Tighten drain valve handle and reposition to CLOSED position.
	D. Loose wire connections on gas valve or interface board.	D. Repair loose connections.
	E. Defective gas valve relay.	E. Replace gas valve relay.
POWER SWITCH ON, HEAT LIGHT OFF, TROUBLE LIGHT ON, BURNER OFF.	A. Pilot light out (fryers with series code prior to AH).	A. Relight pilot light.
	B. Fryer manual gas valve closed.	B. Open manual gas valve.
	C. Defective hi-limit thermostat.	C. Replace hi-limit.
	D. Defective pilot generator cartridge.	D. Replace pilot generator.
	E. Shortening temperature above 425°F(218°C)(fryers with series code prior to AH).	E. Turn power switch OFF, allow to cool below normal cooking temperature and restart.
POWER SWITCH ON, POWER LIGHT OFF.	A. No power to fryer.	A. Check power cord to verify plugged into receptacle.
	B. Defective power switch.	B. Replace controller.
	C. Loose controller wire harness.	C. Reseat wire harness connectors on controller and interface board.
	D. Defective 12-volt transformer.	D. Replace 12-volt transformer.
POWER SWITCH ON, POWER LIGHT ON, HEAT LIGHT OFF, TROUBLE LIGHT (?) ON.	A. Defective controller.	A. Swap controller with another fryer or test controller with MTB-310A tester. Replace if found defective.
	B. Temperature sensing probe defective.	B. Check continuity or resistance of probe circuit. Replace probe if found defective.

PROBLEM	PROBABLE CAUSE	CORRECTIVE ACTION
FRYER DOES NOT COME OUT OF MELT FUNCTION.	A. Defective controller.	A. Swap controller with another fryer or test controller with MTB-310A tester. Replace if found defective.
	B. Defective temperature sensing probe.	B. Check continuity or resistance of probe circuit. Replace probe if found defective.
FRYER DOES NOT GO INTO MELT FUNCTION, BURNER ON CONTINUOUSLY WHEN SHORTENING IS COLD.	A. Melt switch in OFF position.	A. Place melt switch ON.
	B. Gas valve relay stuck closed.	B. Replace gas valve relay.
	C. Gas valve diaphragm ruptured.	C. Replace gas valve.
SLOW RECOVERY.	A. Burner manifold pressure too low.	A. Use a manometer and adjust burner manifold pressure — 3.5 in. W.C. (0.86kPa) Natural Gas, .25 in. W.C. (2.05kPa) L.P. Gas.
	B. Gas valve regulator defective.	B. Replace gas valve.
	C. Burner targets out of alignment.	C. Align burner targets (see Service Procedures).

FOR OTHER BURNER RELATED MALFUNCTIONS, SEE TROUBLESHOOTING GUIDE — FRYERS WITH COMPUTER AND FRYERS EQUIPPED WITH STANDARD THERMOSTAT.

14. TROUBLESHOOTING GUIDE — FRYERS EQUIPPED WITH STANDARD THERMOSTAT

WARNING

Inspection, testing and repair of electrical equipment should be performed only by qualified service personnel. The unit should be unplugged when servicing, except when electrical tests are required.

DANGER: Use extreme care during electrical circuit tests. Live circuits will be exposed.

NOTE: This guide does not include every possible problem and the cause. However, careful observation of all malfunction indications and logical troubleshooting will help in correcting the problem in a more expedient manner.

NOTE: See SERVICE PROCEDURES to replace fryer components.

PROBLEM	PROBABLE CAUSE	CORRECTIVE ACTION
PILOT OUTAGE (RED TROUBLE LIGHT ON IF EQUIPPED).	A. Automatic gas valve knob turned to OFF position.	A. Set knob to pilot position and relight pilot.
	B. Low pilot flame.	B. Adjust pilot flame up. See Service Procedure 21.
	C. Clogged pilot orifice.	C. Clean pilot orifice carefully or replace.
	D. Low incoming gas pressure.	D. Increase gas pressure at building regulator.
	E. Pilot flame blowing away from thermopile (excessive draft in kitchen).	E. Reposition thermopile into pilot flame and eliminate draft.
	F. Thermopile not inserted all the way into pilot assembly.	F. Insert thermopile up into pilot until flame surrounds tip.
	G. Defective thermopile.	G. Replace thermopile.
	H. Defective hi-limit thermostat.	H. Replace hi-limit thermostat. See Service Procedure 3 or 4.
	I. Defective pilot safety magnet in gas valve.	I. Replace gas valve. See Service Procedure 12.
	J. Defective hi-limit adaptor wire assembly.	J. Replace hi-limit adapter wire assembly. See Service Procedure 16.
CONTROL PANEL INDICATOR LIGHTS OUT.	K. Loose thermopile connection at pilot magnet.	K. Tighten connection finger tight plus 1/4 turn with wrench.
	A. Wire terminals loose or disconnected from lights.	A. Tighten or reinstall terminals.
	B. Power cord set unplugged.	B. Plug power cord into wall receptacle.
	C. Defective bulbs.	C. Replace indicator lights.

PROBLEM	PROBABLE CAUSE	CORRECTIVE ACTION
DELAYED IGNITION ON MAIN BURNER.	A. Burner deflector(s) out of adjustment.	A. Adjust deflectors to proper position. See Service Procedure 19.
	B. Broken or missing ceramic deflector target(s).	B. Replace ceramic deflector target(s). See Service Procedure 17.
	C. Pilot flame misdirected away from first burner orifice.	C. Adjust pilot flame. See Service Procedure 21.
	D. Obstruction in pilot deflecting flame away from first burner orifice.	D. Clear obstruction from pilot and redirect pilot flame at first burner orifice.
	E. Pilot bracket bent.	E. Replace or straighten pilot bracket.
	F. Draft in kitchen.	F. Eliminate draft in kitchen.
	G. Pilot flame too small.	G. Adjust pilot flame up. See Service Procedure 21.
	H. Pilot orifice clogged.	H. Clean or replace pilot orifice.
	I. Main burner gas pressure too low.	I. Adjust fryer gas valve regulator to proper pressure. See Service Procedure 22 for burner pressure.
	J. Gas line to fryer too small.	J. Replace gas line with proper size. See Installation Instructions for proper size.
FLAME ROLLING OUT FROM UNDER FRYER.	A. Flue obstructed.	A. Clear obstruction from flue.
	B. Flue insulation retainer broken loose at bottom of flue.	B. Remove flue from frypot and replace flue insulation retainer.
MAIN BURNER LIGHTING ON ONE SIDE ONLY.	A. Rear deflector target burned off or broken.	A. Remove burner and replace rear deflector and target. See Service Procedure 18.
	B. Rear burner orifices clogged.	B. Clean orifices with proper orifice drill No. 1.45mm Nat. Gas, No. 0.86mm LP Gas.
	C. Burner manifold gas pressure too high.	C. Adjust fryer gas valve regulator to proper pressure. See Service Procedure 22 for burner manifold pressure.
	D. Rear Deflector target out of alignment.	D. Adjust rear deflector target to proper position. See Service Procedure 19.
THERMOSTAT DOES NOT CONTROL AT SET POINT.	A. Thermostat out of calibration.	A. Recalibrate thermostat. See Service Procedure 5.
	B. Contaminated or burned contacts.	B. Replace Thermostat. See Service Procedure 3 or 4.
	C. Knob or flexible shaft loose on thermostat adjusting screw.	C. Calibrate and tighten all set screws on flexible shaft and knob. See Service Procedure 5.

PROBLEM	PROBABLE CAUSE	CORRECTIVE ACTION
THERMOSTAT DOES NOT CALL FOR HEAT.	A. Knob set too low.	A. Increase setting.
	B. Thermostat wires disconnected or damaged.	B. Reconnect or repair wires.
	C. Defective thermostat.	C. Replace thermostat. See Service Procedure 3 or 4.
MAIN BURNER DOES NOT COME ON, PILOT LIGHT LIT.	A. Power ON/OFF switch OFF.	A. Press power ON/OFF switch to start and release to ON.
	B. Power ON/OFF switch defective.	B. Replace power ON/OFF switch. See Service Procedure 6.
	C. Automatic gas valve defective.	C. Replace gas valve. See Service Procedure 12.
	D. Defective latch relay. Fryers prior to series AH	D. Replace latch relay.
	E. Frypot drain valve open. (FILTER MAGIC FRYERS ONLY.)	E. Close fryer drain valve.
	F. Frypot drain valve microswitch defective.	F. Replace frypot drain valve microswitch. (FILTER MAGIC FRYERS ONLY.)
	G. Frypot drain valve handle loose, not actuating drain valve microswitch. (FILTER MAGIC FRYERS ONLY.)	G. Tighten drain valve handle (FILTER MAGIC FRYERS ONLY).
FRYER OPERATES NORMALLY BUT RED TROUBLE LIGHT REMAINS ON. FRYERS EQUIPPED WITH TROUBLE LIGHT.	A. Pilot pressure switch defective.	A. Replace pilot pressure switch. See Service Procedure 9. For fryers prior to series AH.
FRYER DOES NOT GO INTO MELT FUNCTION, MELT SWITCH ON, BURNER ON CONTINUOUSLY WHEN SHORTENING IS COLD. (FRYERS EQUIPPED WITH MELT CYCLE).	A. Melt cycle timer defective.	A. Replace melt cycle timer. See Service Procedure 8.
	B. Melt cycle timer microswitch defective.	B. Replace melt cycle timer microswitch.
	C. Melt switch defective on control panel.	C. Replace melt switch on control panel. See Service Procedure 6.
FRYER HAS SLOW RECOVERY.	A. Main burner manifold gas pressure low.	A. Adjust fryer gas valve regulator to proper pressure. See Service Procedure 22.
	B. Fryer incoming gas pressure low.	B. Contact local gas company and see page 4 for incoming pressure.

15. PARTS LIST

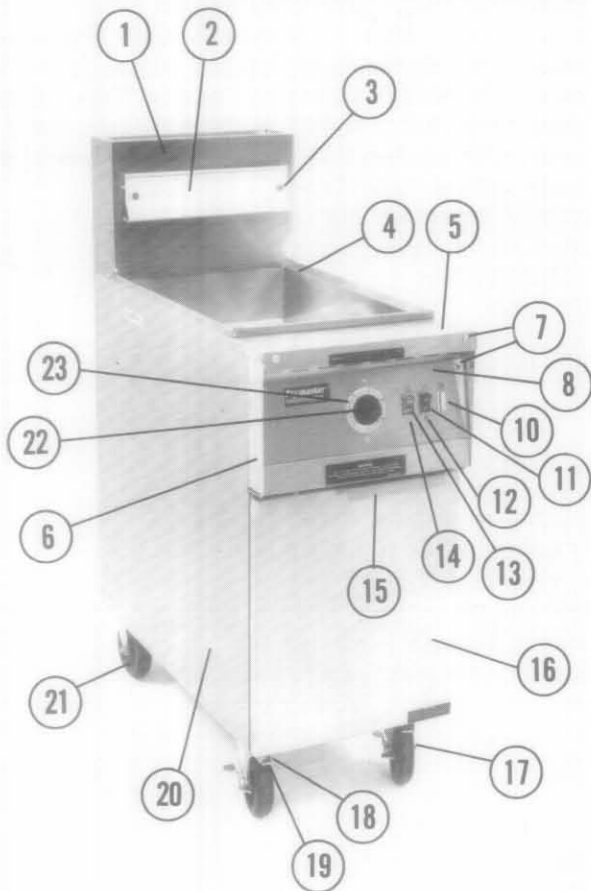

MJ45E With Thermostat Control

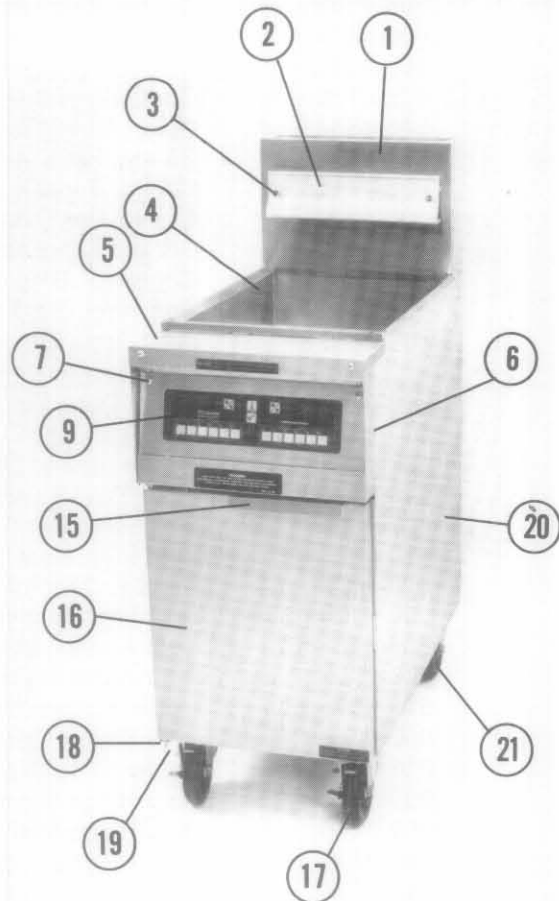

MJ45E With Computer

ITEM	PART NO.	DESCRIPTION
1	910-6545	Flue Cap, 1 Fryer
1	910-9132	Flue Cap, 2 Fryers
1	910-9133	Flue Cap, 3 Fryers
2	803-0028	Basket Hanger for Non-basket Lift Fryers
*	809-0015	Nut Retainer for Basket Hanger Screws
3	809-0171	Basket Hanger Screw
*	807-0154	Power Cord Set
4	806-1370	Frypot Complete (Combustion Chamber, Flue, and Insulation)
4	823-0359	Frypot Only
5	910-3544	Top Cap, 1 Fryer
5	823-0586	Top Cap, 2 Fryers
5	823-0587	Top Cap, 3 Fryers
5	823-0588	Top Cap, 4 Fryers
6	806-4732	Computer or Controller Mounting Frame, 1 Fryer
6	806-4733	Computer or Controller Mounting Frame, 2 Fryers
6	806-4734	Computer or Controller Mounting Frame, 3 Fryers
6	806-5018	Computer or Controller Mounting Frame, 4 Fryers
7	809-0449	Screw, Computer or Controller Mounting Frame (Series AD)
*	809-0177	Tinnerman Clip, Computer or Controller Mounting Frame Screw
8	806-4827	Control Panel Assembly, Without Melt, 2 15-Minute Deihl Mechanical Timers
8	806-4829	Control Panel Assembly, With Melt, 2 15-Minute Deihl Mechanical Timers
8	806-4831	Control Panel Assembly, Without Melt, 2 15-Minute Paragon Timers 120V
8	806-4832	Control Panel Assembly, With Melt, 2 15-Minute Paragon Timers 120V

*Not Shown

ITEM	PART NO.	DESCRIPTION
8	806-4833	Control Panel Assembly, With Melt, 2 5-Minute Paragon Timers 120V
8	806-4834	Control Panel Assembly, Without Melt, 2 5-Minute Paragon Timers 120V
8	806-4835	Control Panel Assembly, Without Melt, 5-15 Minute Paragon Timer 120V
8	806-4836	Control Panel Assembly, With Melt, 5-15 Minute Paragon Timer 120V
8	806-4837	Control Panel Assembly, With Melt, 2 18-Minute Deltrol Timers 240V
8	806-4838	Control Panel Assembly, Without Melt, 2 18-Minute Deltrol Timers 240V
8	806-4841	Control Panel Assembly, With Melt, No Timer
8	806-4842	Control Panel Assembly Without Melt, No Timer
8	806-4864	Control Panel Assembly Without Melt (Military)
9	806-3705	Computer, Single or Multi-product
9	806-4353	Computer, Basket Lift Timer
9	806-3559	Solid-State Electronic Controller With Thermostat Knob
9	806-2071	Computer or Controller Wire Harness
9	806-3797	Digital Controller
10	807-1525	Indicator Light
11	807-1404	Switch, Power ON/OFF 24 V Lamp, Red
12	940-0176	Insert Clip, Switch Hole Control Panel
13	807-0046	Melt Switch for Fryers With Melt Cycle
14	810-0333	Hole Plug, Back for Fryers Without Melt Cycle
15	910-3672	Handle, Door for Universal Doors Only
*	809-0266	Screw for Door Handle and Door Edge
16	806-1961SP	Door Assembly, Universal, Painted
16	806-1962SP	Door Assembly, Universal, Stainless Steel
*	810-0066	Magnetic Door Catch
*	900-0048-1	Door Striker Plate
17	810-0357	Caster, 5" With Brake
18	900-0734-1	Door Hinge Bracket
19	809-0216	Door Hinge Pin
*	810-0275	Door Hinge Pin Spring
*	810-0274	Door Hinge Pin Keeper
20	901-9323	Cabinet Side, CRS, Left, Without Holes
20	902-9323	Cabinet Side, CRS, Right, Without Holes
20	911-9323	Cabinet Side, SS, Left, Without Holes
20	912-9323	Cabinet Side, SS, Right, Without Holes
20	901-9324	Cabinet Side, CRS, Left, With Holes
20	902-9324	Cabinet Side, CRS, Right, With Holes
20	911-9324	Cabinet Side, SS, Left, With Holes
20	912-9324	Cabinet Side, SS, Right, With Holes
*	900-0889	Cabinet Side, Hole Cover, CRS (3)
*	900-0890	Cabinet Side, Hole Cover, CRS (1)
*	910-0889	Cabinet Side, Hole Cover, SS (3)
*	910-0890	Cabinet Side, Hole Cover, SS (1)
*	809-0359	Screw, Hole Cover (16)
21	810-0356	Caster, 5" Without Brake
22	810-0334	Knob With Skirt
23	806-0168	Thermostat Dial Plate

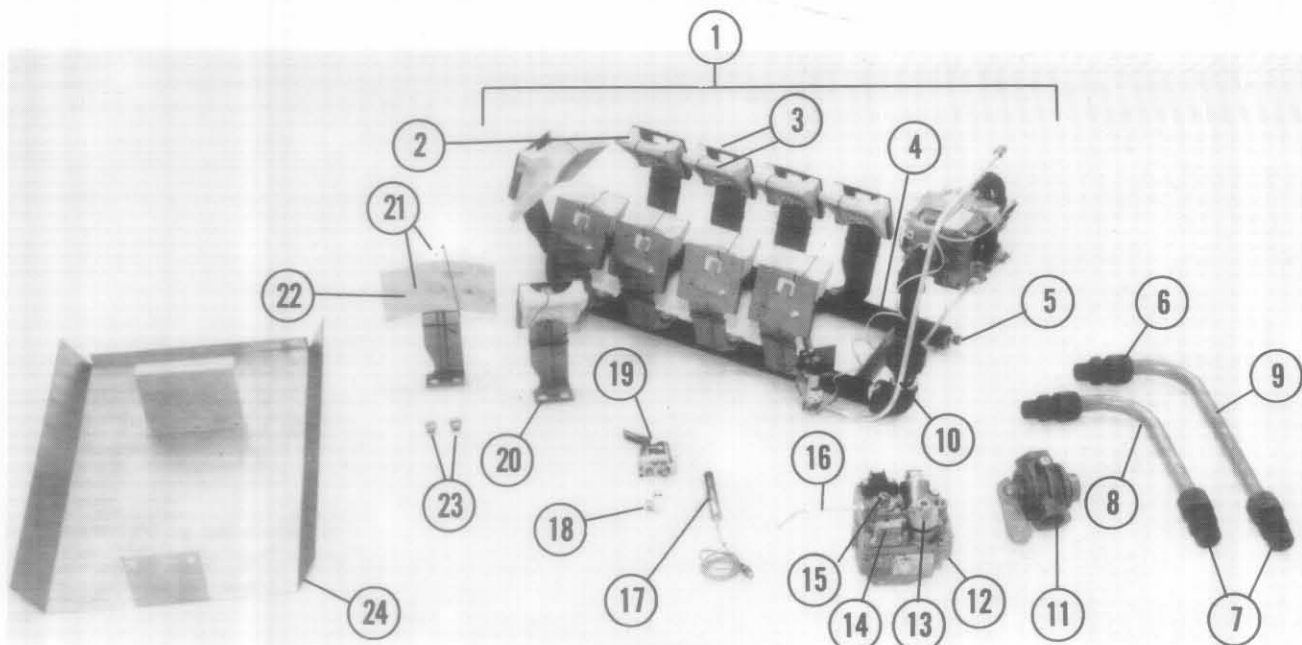

BURNER

ITEM NO.	PART NO.	DESCRIPTION
1	806-1677	Burner and Control Assembly, Nat. Gas
1	806-1678	Burner and Control Assembly, L.P.
1	806-1646	Burner and Control Assembly, Nat. Gas England and Germany
*	809-0170	Burner Mounting Screw
2	814-0034	Ceramic Target, Side Targets Only
3	806-0225	Deflector Assembly, Side Deflectors Only
4	823-0496	Burner Manifold Only
5	813-0154	Pressure Test Port Plug
6	813-0205	Compression Fitting, 3/4TB OD x 1/2PP Use With 940-0747-1 & 2
7	813-0206	Compression Fitting, 3/4TB OD x 3/4PP Use With 940-0747-1 & 2
8	940-0747-1	Curved Input Gas Tube, 5/8 in. for Batteried Fryers W/Manual Shut-off Valve
9	940-0747-2	Curved Input Gas tube, 5/8 in. for Batteried Fryers W/O Manual Shut-off Valve
10	810-0705	Pilot Tubing, Gas Valve to Pilot Burner (Series AH)
*	810-0700	Pilot Tubing, Gas Valve to Pressure Switch, .25 X 8.75 (Prior to Series AH)
*	810-0704	Pilot Tubing, Pressure Switch to Pilot, .25 X 19.50 (Prior to Series AH)
11	810-0239	Manual Gas Shut-off Valve
12	807-0428	Unitrol Gas valve, 24V, Nat. Gas
12	807-0757	Unitrol Gas Valve, 24V, L.P.
12	810-0353	Unitrol Gas Valve, 24V, Nat. Gas, England and Germany
13	810-0109	Gas Valve Knob
14	817-0112	Operator Assembly, 24V
15	810-0187	Regulator, Nat. Gas, 3.5 in. W.C. (0.86 kPa)
15	817-0098	Regulator, L.P. Gas, 8.25 in. W.C. (2.05 kPa)
16	810-0691	Vent Tube. 1/8 in. (3.17mm)
17	810-0617	Pilot Generator Cartridge (Thermopile)
17	807-0699	Thermocouple, 20 in. (50.8cm) England and Germany
18	810-0149	Pilot Orifice, ITT TJ024, Nat. Gas
18	810-0148	Pilot Orifice, ITT TJ013, L.P.
18	810-0126	Pilot Orifice, Robertshaw, .018 England and Germany
19	810-0426	Pilot Burner, ITT 262A38, Nat. Gas
19	810-0427	Pilot Burner, ITT 262A38, L.P.
19	810-0154	Pilot Burner, Robertshaw, 3CH6, Nat. Gas, England and Germany
20	910-0226	Deflector Bracket
21	806-3606	Deflector Assembly, Wide Rear Only
22	810-0424	Ceramic Target, Wide Rear Only
23	810-0315	Burner Orifice, #53 (1.45mm) Nat. Gas
23	810-0340	Burner Orifice, #65 (0.86mm) L.P.
23	810-0330	Burner Orifice, #54 (1.40mm) Nat. Gas, England and Germany
24	823-0574	Burner Suspended Heat Shield

*Not Shown

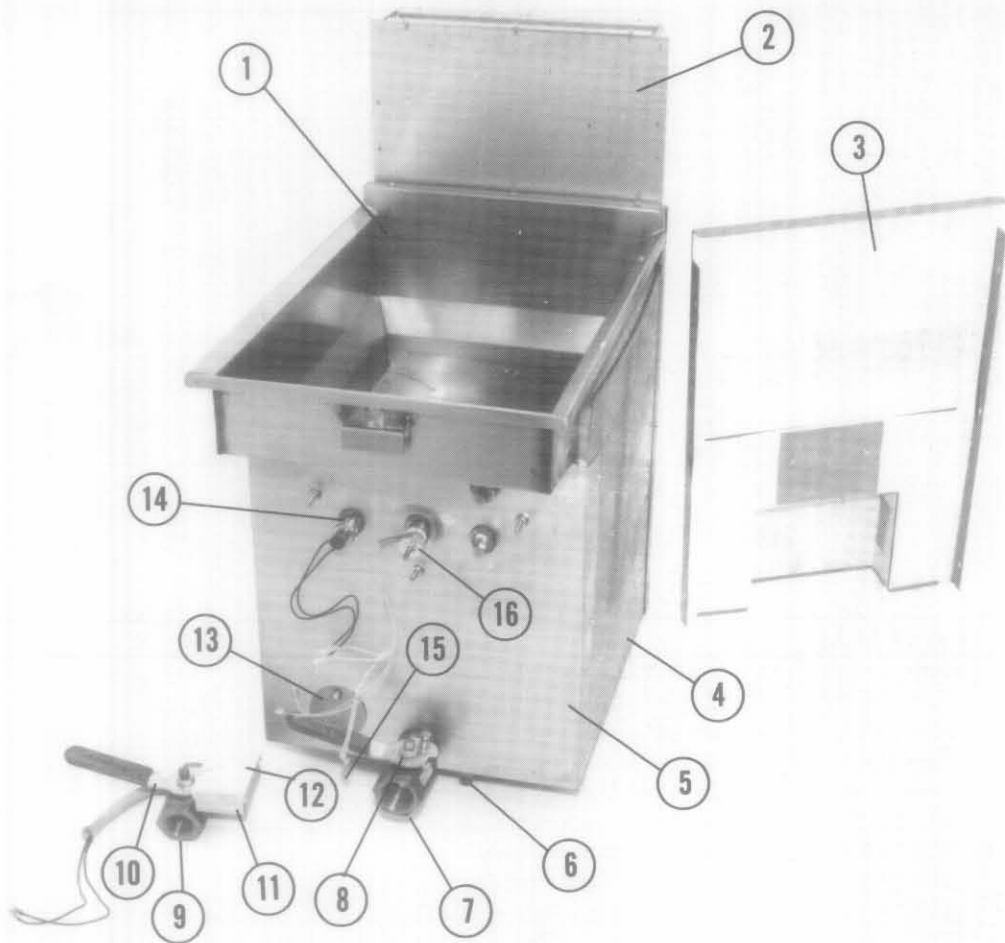

FRYPOT

ITEM NO.	PART NO.	DESCRIPTION
1	806-1370	Frypot Complete (Combustion Chamber, Flue, and Insulation)
*	806-3865	Frypot Complete, Hardee's Only
*	826-0861	Frypot Insulation Kit for Whole Frypot
2	806-1092	Flue Assembly
3	806-1096	Rear Combustion Chamber Baffle Assembly (Must be Ordered With 806-1092)
4	806-1097	Frypot Baffle Pot Side, Fits Left or Right
5	806-1095	Frypot Baffle Pot Front
6	809-0173	Tinnerman Clip Nut
7	806-4145	Drain Valve, 1-1/4" (37mm) With Lock Pin, Without Filter Magic
8	810-0662	Drain Valve Handle With Lock Pin
9	823-1363	Drain Valve, 1-1/4" X 1" Without Lock Pin, With Filter Magic
10	810-05831	Drain Valve Handle Without Lock Pin
11	806-4791	Safety Drain Switch Box Filter Magic ONLY
*	807-0027	Safety Drain Switch
12	900-1101	Safety Drain Switch Box Cover
13	900-1090	Pilot Hole Cover
14	806-0178	Hi-limit Thermostat With Adapter Wire 435°F (224°C)
15	807-0280	Hi-limit Wire Adapter
16	806-0183	Operating Thermostat (MJ45E Standard Only)
*	806-4206	Temperature Sensing Probe, Minco (MJ45E With Computer Only)

*Not Shown

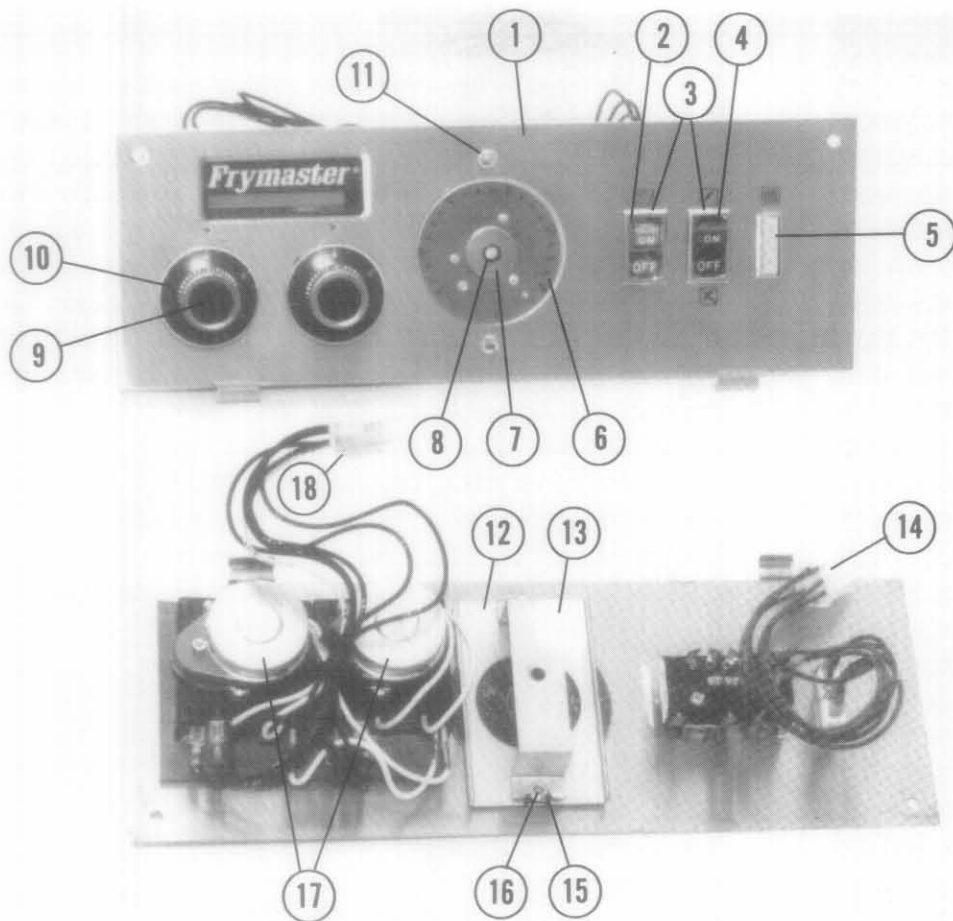

CONTROL PANEL

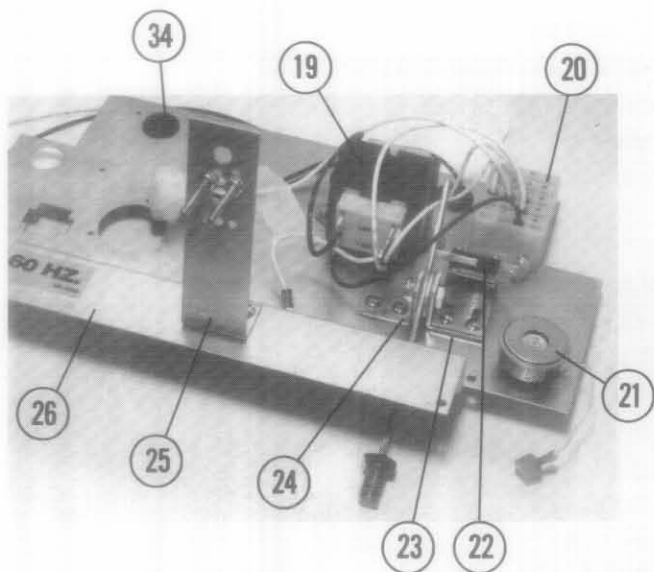

COMPONENT SHIELD
MJ45E WITH THERMOSTAT CONTROL

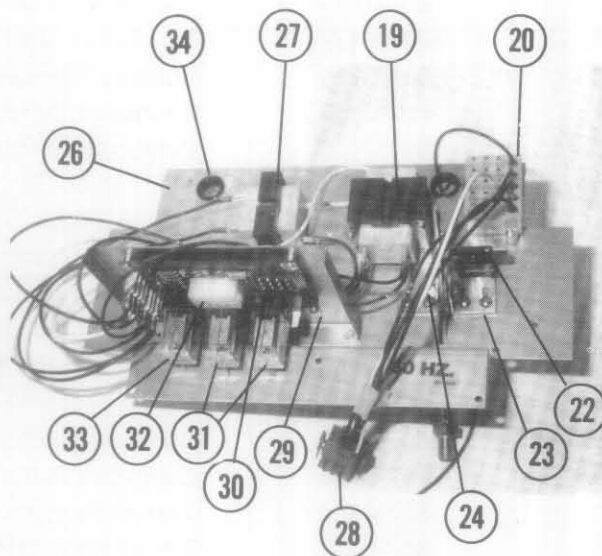

COMPONENT SHIELD
MJ45E WITH COMPUTER

SEE PAGES 31 & 32 FOR PARTS LIST

ITEM NO.	PART NO.	DESCRIPTION
1	806-4827	Control Panel Assembly, Without Melt, 2 15-Minute Deihl Mechanical Timers
1	806-4829	Control Panel Assembly, With Melt, 2 15-Minute Deihl Mechanical Timers
1	806-4831	Control Panel Assembly, Without Melt, 2 15-Minute Paragon Timers 120V
1	806-4832	Control Panel Assembly, With Melt, 2 15-Minute Paragon Timers 120V
1	806-4833	Control Panel Assembly, With Melt, 2 5-Minute Paragon Timers 120V
1	806-4834	Control Panel Assembly, Without Melt, 2 5-Minute Paragon Timers 120V
1	806-4835	Control Panel Assembly, Without Melt, 5-15 Minute Paragon Timers 120V
1	806-4836	Control Panel Assembly, With Melt, 5-15 Minute Paragon Timers 120V
1	806-4837	Control Panel Assembly, With Melt, 2 18-Minute Deltrol Timers 240V
1	806-4838	Control Panel Assembly, Without Melt 2 18-Minute Deltrol Timers 240V
1	806-4841	Control Panel Assembly, With Melt, No Timer
1	806-4842	Control Panel Assembly, Without Melt, No Timer
1	806-4864	Control Panel Assembly, Without Melt (Military)
*	828-0129	Control Panel Plate, With Melt, With Mechanical Timers
*	828-0128	Control Panel Plate, With 2 Mechanical Timers
*	828-0132	Control Panel Plate, Without Melt, With Mechanical timers
*	828-0130	Control Panel Plate, No Timers (Military)
2	807-0046	Switch, Melt ON/OFF Amber
*	810-0333	Hole Plug for Fryers Without Melt Cycle
3	940-0176	Insert Clip, Switch Hole Control Panel
4	807-1404	Switch, Power ON/OFF 24V Lamp, Red
5	807-1525	Light, 24V
6	806-0168	Temperature Dial Plate
7	900-0031	Plug Button
8	807-0123	Heyco Bushing For Plug Button 900-0031
9	810-0590	Knob, Timer Mechanical, 15-Minute
*	807-0766	Push Button, Orange, Paragon Timer Only
10	820-0027	Knob Plate, Timer Paragon 5-Minute
10	820-0025	Knob Plate, Timer Paragon 15-Minute
11	809-0103	Screw, 8-32 X 1/2
12	900-1579	Temperature Dial Lock Plate
*	809-0177	Tinnerman Clip Nut for Thermostat Dial Lock Plate
13	930-0359	Bracket, Thermostat Hat
14	807-0155	Connector, 9-Pin Male
14	807-0156	Connector, 9-Pin Female
15	809-0247	Nut, Keps 8-32
16	809-0103	Screw, 8-32 X 1/2
17	810-0585	Timer, Mechanical 15-Minute
17	807-0103	Timer, Paragon 5-Minute 120V 60 Hz.
17	807-0104	Timer, Paragon 15-Minute 120V 60 Hz.
17	807-0106	Timer, Paragon 15-Minute 240V 50/60 Hz.
17	807-0401	Timer, Deltrol 18-Minute 240V 50/60 Hz.
18	807-0157	Connector, 6-Pin Male
18	807-0158	Connector, 6-Pin Female
19	807-0800	Transformer, 120/24 Volts
19	807-0547	Transformer, 208/240/24 Volts, Export
19	807-0522	Transformer, 220/24V Germany
20	807-0066	20-Hole Terminal Block
*	807-0255	Double Jumper for 807-0066

*Not Shown

ITEM NO.	PART NO.	DESCRIPTION
21	806-4797	Sound Device, Filter Magic Fryers Only
22	807-0027	Pump Control Microswitch
23	930-0839	Bracket, Control Microswitch Mounting
24	817-0109	Kit, Oil Return Pump Control Handle Linkage, Filter Magic Only
*	810-0104	Ball Knob For Pump Control Handle
25	806-0066	Thermostat Shaft Stop Plate
*	813-0389	Pressure Switch "T" Fitting (Prior to Series AH)
*	806-1076SP	Pressure Switch Kit (Prior to Series AH)
*	807-0883	Melt Cycle Timer 50 Hz 24V
*	806-1661	Melt Cycle Timer 60 Hz 24V
*	807-0345	Melt Timer Microswitch
26	900-4340	Component Mounting Shield Plate
27	807-0855	Transformer, 120/12 Volts
27	807-0979	Transformer, 208/240/12 Volts, Export
28	807-0160	Connector Plug, Male 12-Pin
*	807-0257	Connector Plug, Female
29	900-0962	Interface Board Bracket
30	806-3548	Interface Board
31	807-0834	Basket Lift Relay
32	807-0804	Connector Plug, Female 15-Pin
*	807-0258	Connector Plug, Male
33	807-0833	Gas Valve Relay
34	810-0045	Heyco Bushing
*	806-3549	Control Shield Wire Harness
*	806-2071	Controller or Computer Wire Harness
*	806-3660	Sound Device
*	806-4781	Capacitor Assembly

*Not Shown

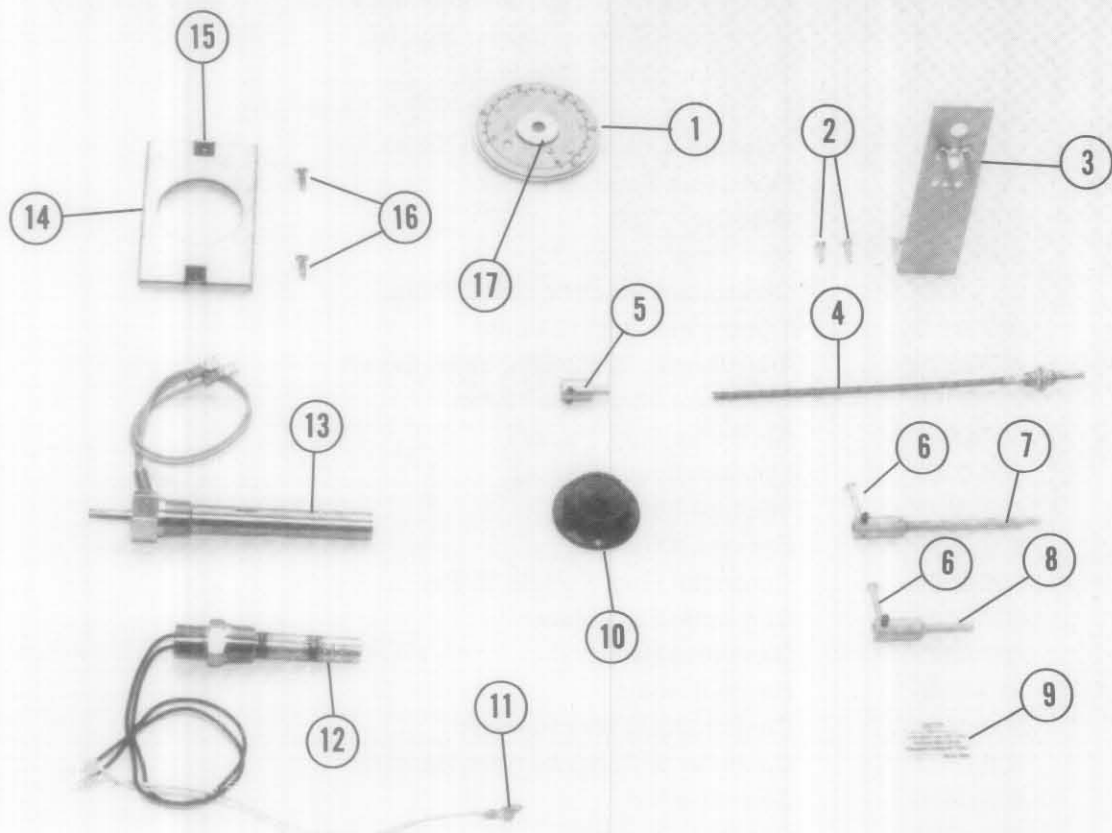

THERMOSTAT RELATED PARTS

ITEM NO.	PART NO.	DESCRIPTION
1	806-0168	Thermostat Dial Plate
2	809-0104	Screw, Thermostat Shaft Stop Plate
*	809-0237	Nut, Thermostat Shaft Stop Plate
3	806-0066	Thermostat Shaft Stop Plate
4	810-0729	Thermostat Flexible Extension Shaft
*	810-0008	Thermostat Flexible Extension Shaft (Prior to Series AH)
5	810-0009	Adapter For Flexible Extension Shaft (Prior to Series AH)
6	809-0111	Thermostat Stop Screw
7	810-0364	Solid Adapter Shaft 3-1/2 in. long for Filter Magic Fryers (Prior to Series AH)
8	810-0276	Solid Adapter Shaft 2-1/2 in. Long
9	802-0045	Caution Label, Thermostat Adjustment Warning
10	810-0334	Knob With Skirt
11	807-0280	Hi-Limit Thermostat Adapter Wire Assembly
12	806-0178	Hi-Limit Thermostat
13	806-0183	Operating Thermostat
14	900-1579	Thermostat Dial Lock Plate
15	809-0177	Tinnerman Clip Nut For Thermostat Dial Lock Plate
16	809-0103	Screw For Thermostat Dial Lock Plate
17	900-0031	Plug Button
*	807-0123	Heyco Bushing For 900-0031

*Not Shown

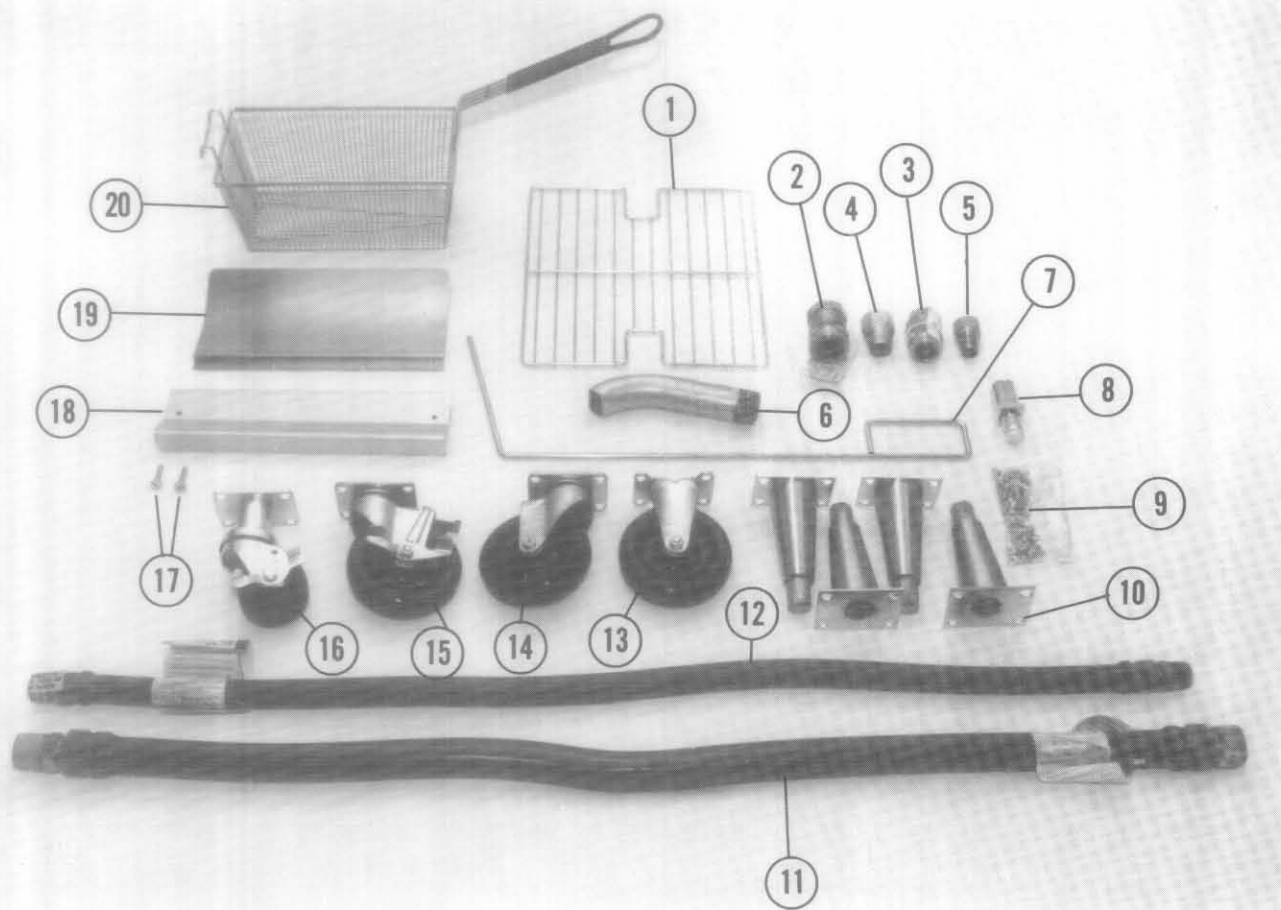

ACCESSORIES

ITEM	PART NO.	DESCRIPTION
1	803-0132	Basket Support Rack
2	810-0074	Quick Disconnect, Male 1 in. (25.4mm)
3	810-0070	Quick Disconnect, Male 3/4 in. (19.05 mm)
4	810-0073	Quick Disconnect, Female 1 in. (2.4mm)
5	810-0072	Quick Disconnect, Female 3/4 in. (19.05mm)
6	813-0188	Drain Extension Pipe
7	803-0047	Frypot Cleanout Rod (Fryer's Friend)
8	810-0007	Adjustable Leg, Filter Cabinet
9	809-0131	Screw, Leg Mounting
10	806-3811	Leg (4-leg Kit)
*	806-5043	Leg (1-leg Kit)
11	810-0085	Flexible Gas Hose, 1 in. (25.4mm) ID, 48 in. (1.2m) long
12	810-0084	Flexible Gas Hose, 3/4 in. (19.05mm) ID, 48 in. (1.2m) long
13	810-0378	Caster, Rigid
14	810-0356	Caster, 5" Without Brake
15	810-0357	Caster, 5" With Brake
16	810-0651	Caster, With Brake Filter Cabinet
17	809-0171	Basket Hanger Screw
18	803-0028	Basket Hanger, for Non-Basket Lift Fryers
19	910-3557	Flue Heat Deflector
20	803-0022	Twin Basket

*Not Shown

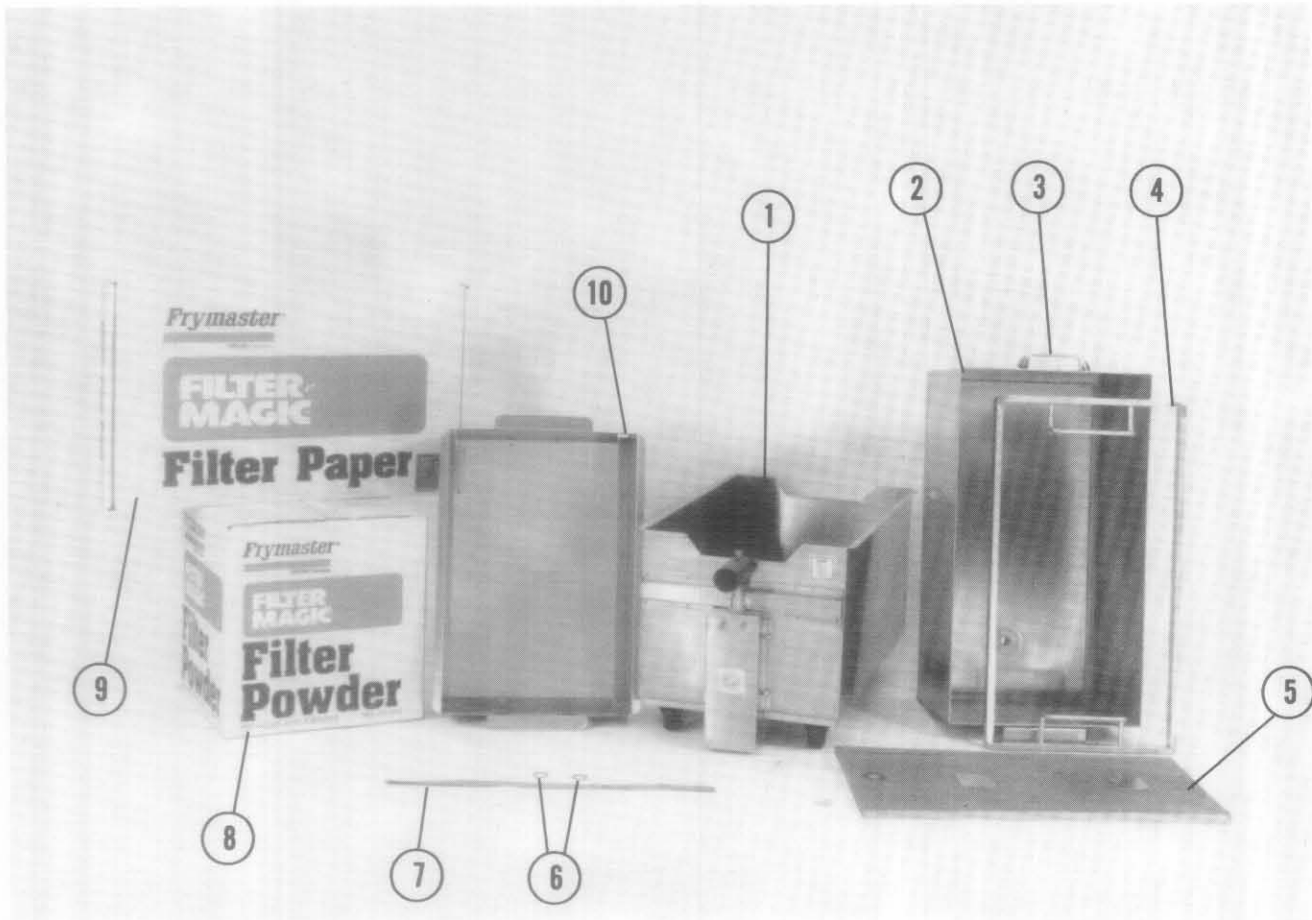

FILTER MAGIC II PARTS LIST

ITEM	PART NO.	DESCRIPTION
1	806-4338	Pan, Outer (Complete)
2	806-5282	Pan, Inner
3	810-0180	Handle, Inner Pan
*	809-0024	Screw, Handle
4	823-17331	Filter Paper Hold-down Ring
5	823-1732	Screen, Filter Pan
6	816-0117	O-Ring, Inner Pan Fitting
7	806-4373	Pan Heater
8	803-0002	Filter Powder
9	803-0154	Filter Paper
10	823-1362	Crumb Screen

*Not illustrated.

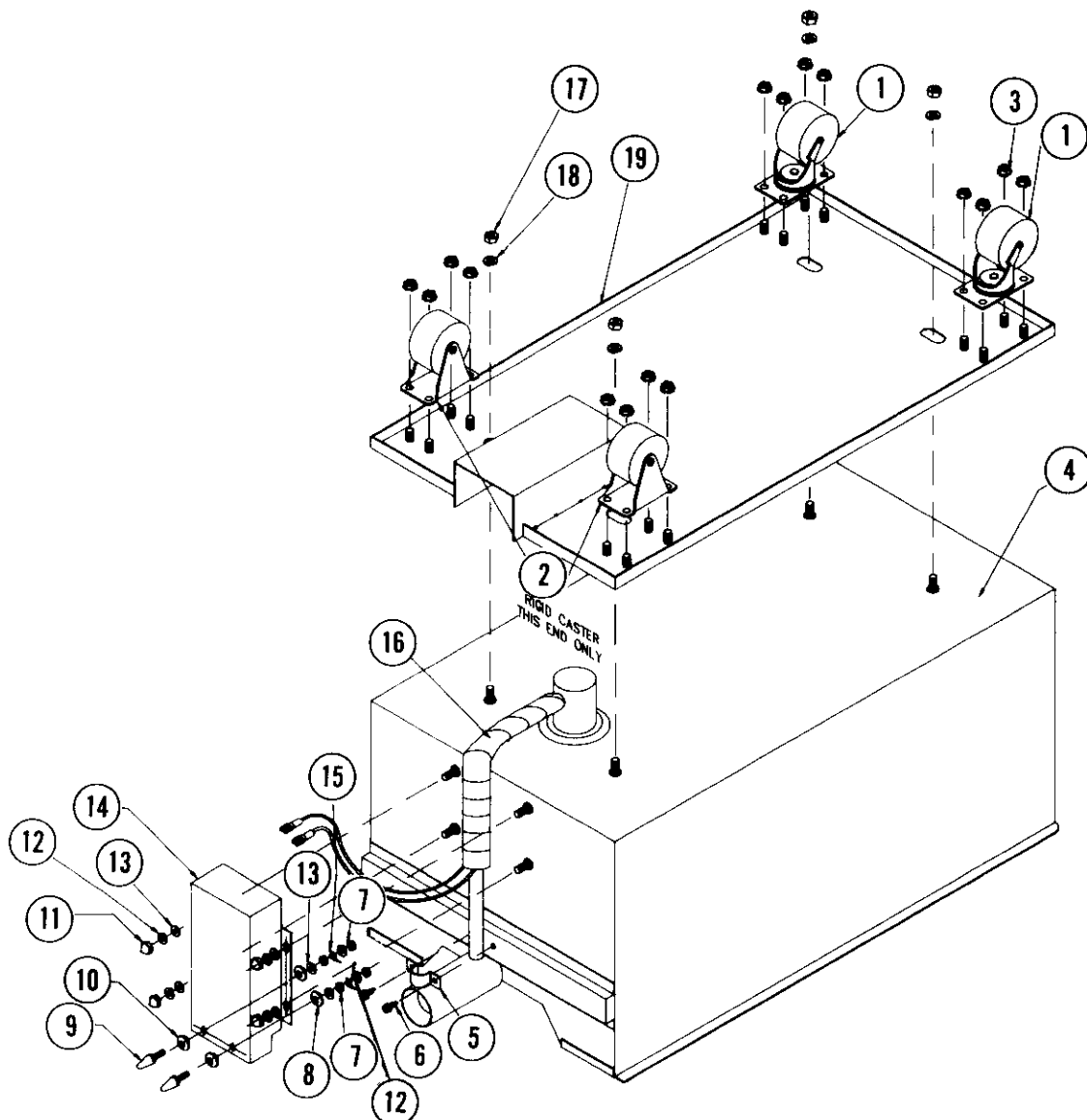

FILTER MAGIC II PARTS LIST - CONTINUED

ITEM	PART NO.	DESCRIPTION
1	810-0006	Caster, 2 in. Swivel
2	810-0005	Caster, 2 in. Rigid
3	809-0256	Keps Lock Nut
4	823-1360	Pan, Only
5	910-1350	Clamp, Suction Tube
*	813-0411	Pipe Plug
6	809-0361	Screw Drill
7	809-0053	Nut 10-32
8	807-1367	Insulator Filter Contacts
9	810-0695	Contactor Pan Heater
10	807-1270	Insulator Shoulder
11	809-0020	Nut, Cap 10-24
12	809-0184	Lock Washer, #10
13	809-0185	Flat Washer #10
14	824-0291	Cover, Suction Tube
15	807-0037	Terminal Tab
16	806-4373	Pan Heater
17	809-0071	Base Mount Nut
18	809-0189	Washer, Flat 1/4"
19	823-1361	Base, Outer Pan

*Not illustrated.

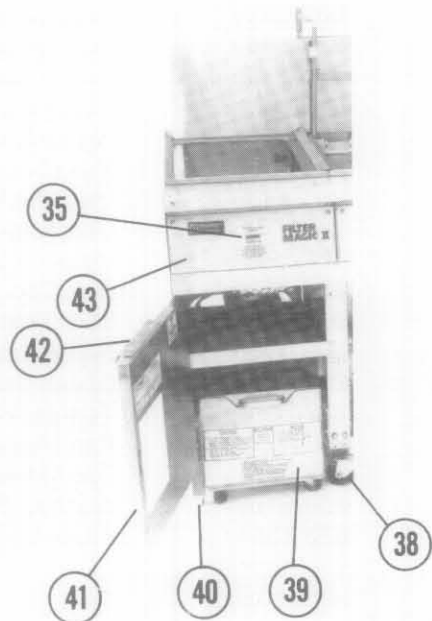
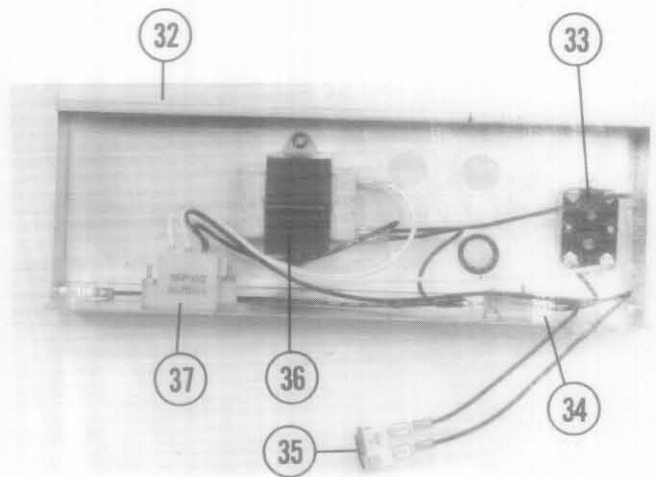
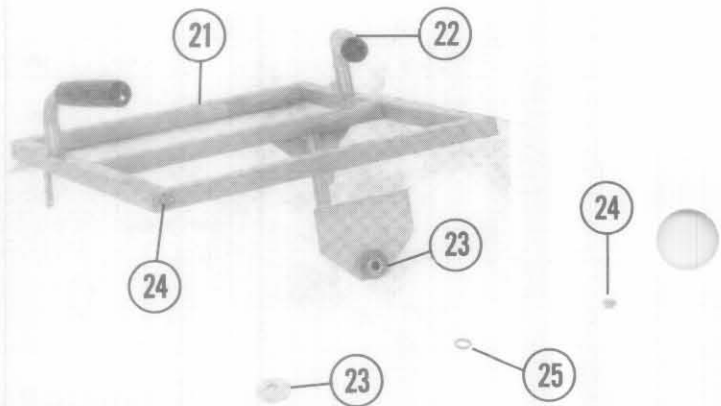
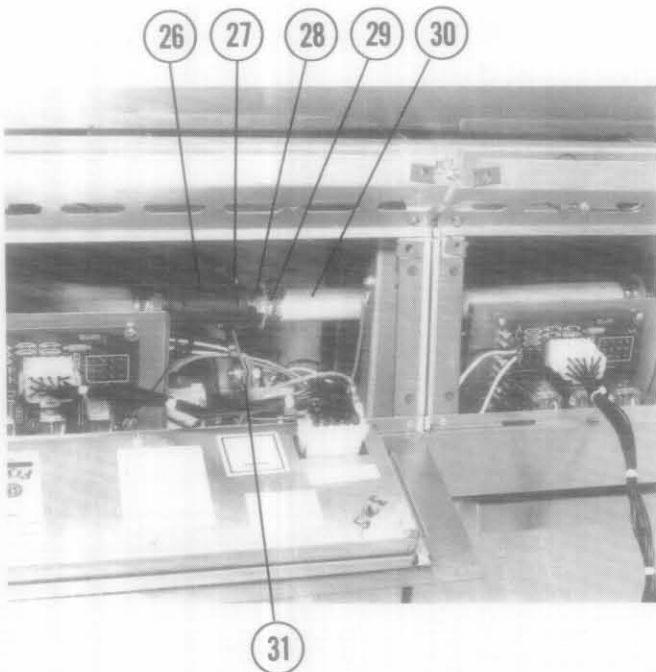
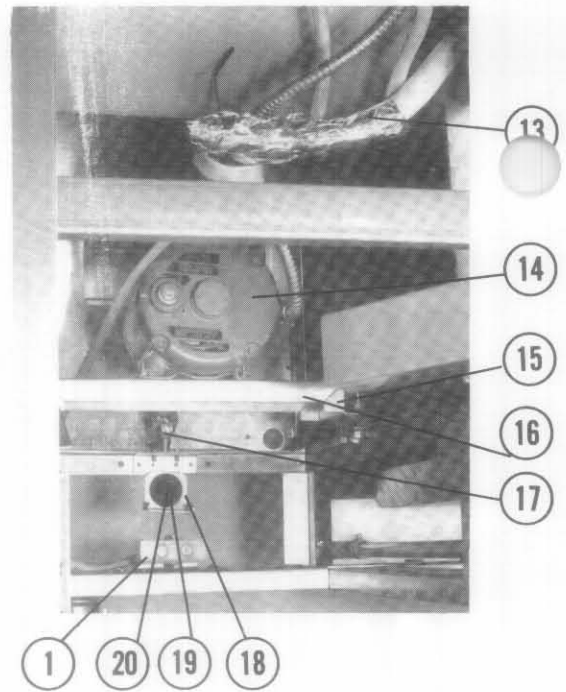
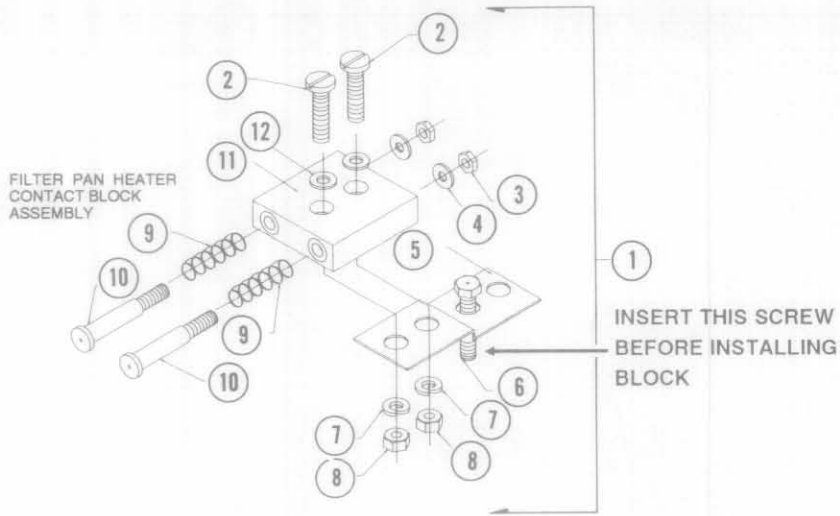

FILTER MAGIC II PARTS LIST - CONTINUED

ITEM	PART NO.	DESCRIPTION
1	806-4694	Contactora Block Assembly
2	809-0291	Block Mount bolt
3	809-0053	Nut, 10-32
4	809-0185	Flat Washer, #10
5	910-1521	Block Mount Bracket
6	809-0131	Bracket Mount bolt
7	809-0191	Lock Washer
8	809-0071	Block Mount Nut
9	810-0696	Contact Spring
10	810-0693	Contact Pin
11	810-0694	Contactora Block (only) Pan Heater
12	809-0435	Flat Washer 1/4"
13	807-1408	FM Heater Pump and Line 120V, 70 in. 50W
13	807-1409	FM Heater Pump and Line 240V, 70 in. 90W
14	807-1197	Motor, Pump 120V
14	807-1266	Motor, Pump 240V
*	807-1197-1	Motor and Gasket Kit
*	807-1197-2	Pump and Gasket Kit
*	807-1197-3	Complete Seal Kit
15	810-0665	Pump Motor Mount Frame Leveling Nut
16	900-4175	Pump Motor Mount Frame
17	823-1356	Connector, Oil Pickup, Filter Magic
18	900-1472	Oil Diverter
19	816-0102	Oil Diverter Grommet
20	816-0012	O-ring, Oil Pickup Tube
21	806-4503	Power Shower
22	814-0001	Handle Grip
23	816-0025	Gasket, Power Shower
24	809-0415	Power Shower Clean-out Screw
25	816-0071	O-ring, Power Shower
*	806-0396	Power Shower Storage Box
26	810-0278	Valve, Oil Return
27	902-0883	Handle, Oil Return Valve, Right
28	813-0376	Hose Fitting
29	810-0668	Hose Clamp
30	811-0847	Hoses — Specify Length
31	817-0109	Linkage Kit
*	930-0839	Bracket, Pump Control Switch (Shown on Page 32)
*	920-0219	Bracket, Handle Pivot
*	807-0027	Microswitch (Shown on Page 32)
32	806-3256	Transformer Box W/Components, 120V
32	806-3349	Transformer Box W/Components, 240V
33	807-0012	Pump Relay
34	806-4358	Resistor Ready Light
35	807-1275	Light, Heater 2V
36	807-0800	Transformer 120/24
36	807-0547	Transformer 240/24
37	807-0276	12-Pin Terminal Block
*	807-0154	Power cord, Optional
*	810-0104	Ball Knob
*	823-0270	Handle Filter
*	824-0148	Filter Cabinet Cover
38	810-0651	Caster 3", With Brake, Filter Cabinet
39	806-4338	Pan, Outer (Complete)
40	810-0007	Adjustable Leg, Filter Cabinet
41	806-1961SP	Door Assembly, Universal, Painted
41	806-1962SP	Door Assembly, Universal, SS
42	910-3672	Handle, Door for Universal Doors Only
*	809-0266	Screw for Door Handle & Door Edge
43	828-0093	Filter Panel

*Not Shown

FILTER MAGIC II SQUARE DRAIN BREAKDOWN

AFTER MARCH 1990

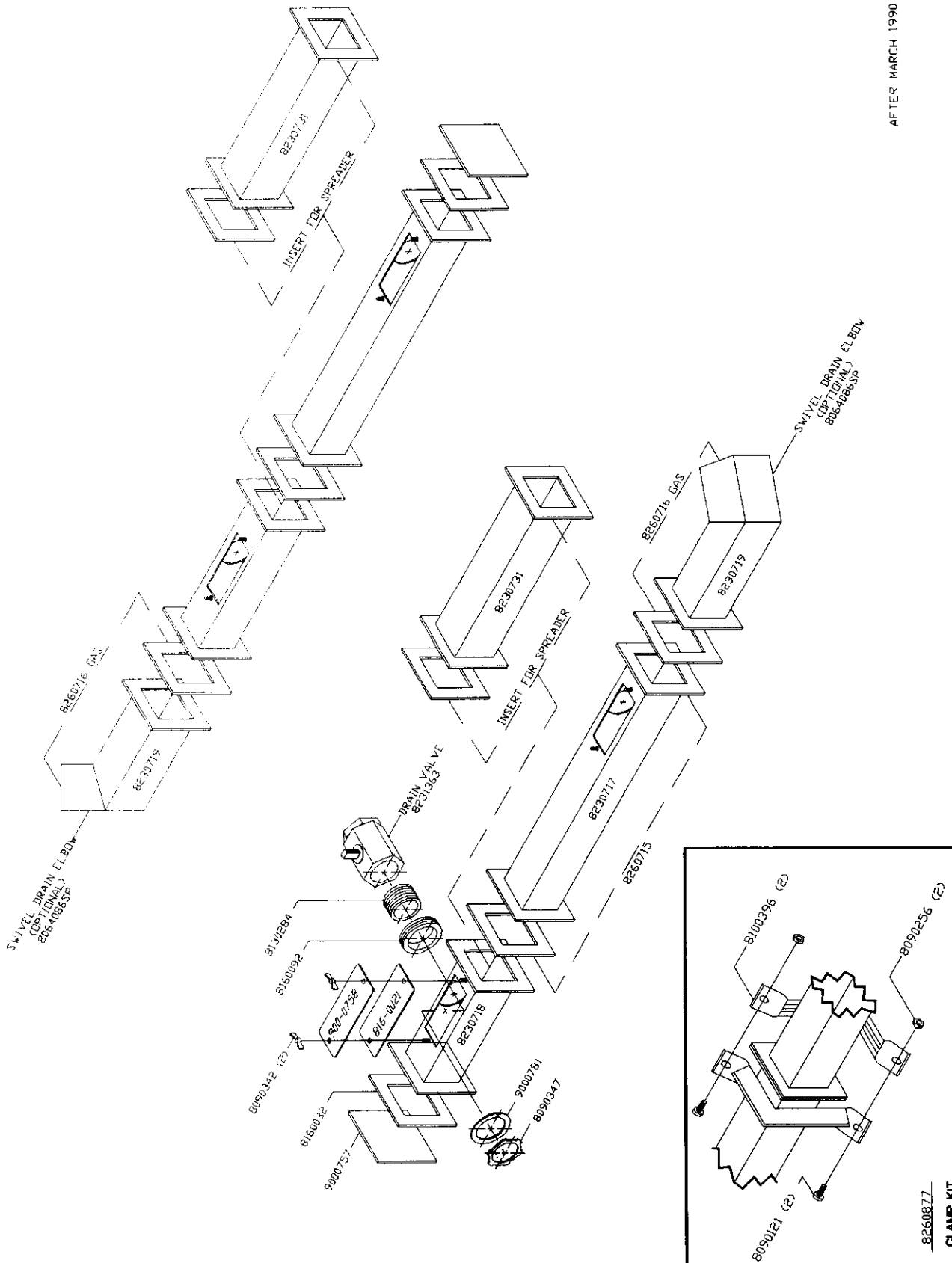

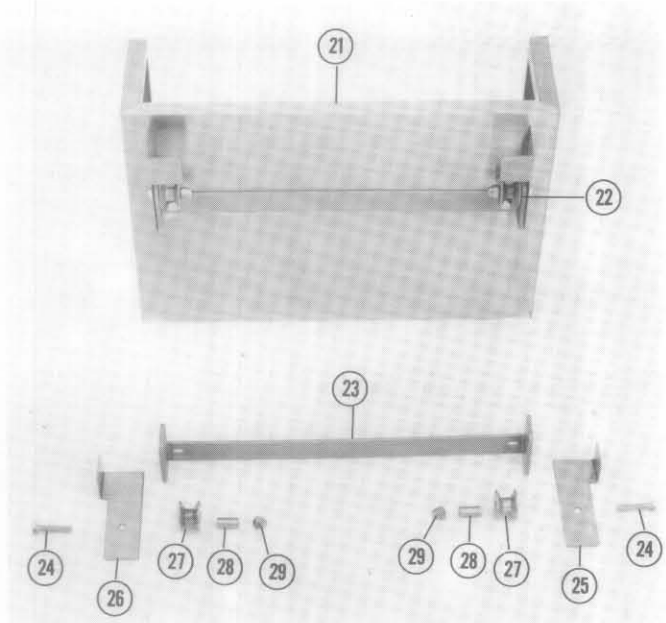
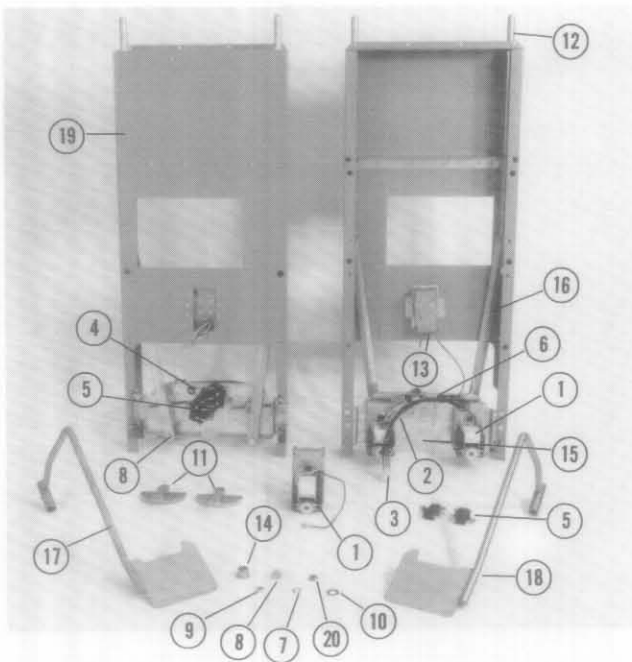

BASKET LIFT

ITEM	PART NO.	DESCRIPTION
1	807-0107	Gear Motor, 120V
1	807-0108	Gear Motor, 240V Export
2	806-2079	Harness, Wiring
3	807-0158	Connector 6-Pin
4	807-0124	Bushing, Heyco
5	807-0240	Switch, Micro
6	809-0037	Clamp, Plastic
*	809-0082	Ring, Truarc Retaining, (Locks Basket Lift Rod Bushing in Place)
7	809-0194	Washer, 5/16
8	809-0155	Screw, Leveling
9	810-0220	Spacer, Tubular
*	809-0196	Washer, 3/8
10	809-0203	Washer, Nylon
11	810-0052	Bellcrank
12	810-0192	Rod Basket Lift
13	810-0045	Bushing, Plastic Handy Box
14	813-0035	Bushing, Basket Lift Rod
15	920-3233	Mount, Motor U
16	920-6076	Link, B/L
*	810-0170	Roll Pin
17	823-06931	Basket Lift Arm, Left
18	823-06932	Basket Lift Arm, Right
19	806-4427	Basket Lift Rear Enclosure, CR, 120V
19	806-44271	Basket Lift Rear Enclosure, SS, 120V
19	806-4428	Basket Lift Rear Enclosure, CR 240V
19	806-44281	Basket Lift Rear Enclosure, SS 240V
20	809-0063	Nut
21	910-6545	Flue Cap, Single
22	806-0235	Basket Lift Roller Bracket Assembly
23	823-0126	Bracket, Basket Lift Roller
24	809-0416	Bolt, 1/4-20 X 1-1/4
25	912-1001	Bracket, Basket Lift Roller Guide, Right
26	911-1001	Bracket, Basket Lift Roller Guide, Left
27	810-0194	Roller, Basket Lift
28	810-0374	Spacer, Tubular
29	809-0047	Nut, Cap 1/4-20

16. SERVICE PROCEDURES

WARNING

Before performing any maintenance on your Frymaster fryer, you must disconnect the electrical power supply.

When electrical wires are disconnected, it is recommended that they be marked in such a way to facilitate reassembly.

Procedure 1: Replacing Computer or Controller

1. Remove two screws from top of controller panel.

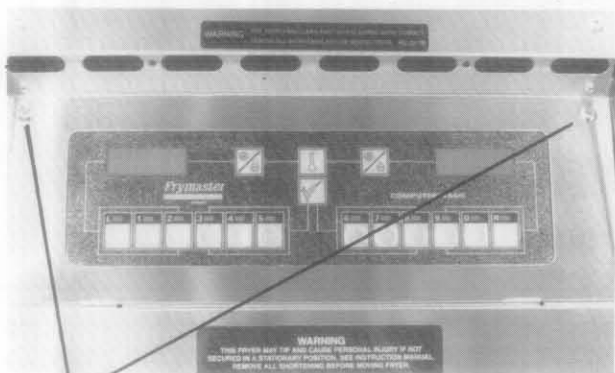

SCREWS

Figure 13

2. Controller panel is hinged at the lower edge and will swing open from the top.
3. Remove wire harness plug and ground wire from back of controller panel.



Figure 14

4. Controller panel can be removed by lifting the assembly from the hinge slots in panel mounting frame.
5. Reverse the above procedure to install controller panel.

Procedure 2: Replacing Temperature Sensing Probe

1. Drain shortening below level of probe.

2. Remove two screws from top of controller panel. (See Figure 13.)
3. Controller panel is hinged at bottom and will swing open from the top.
4. Remove wire harness plug from back of controller panel. (See Figure 14.)
5. Remove controller panel from hinge slots in panel mounting frame.
6. Remove two screws and nuts from base of interface board mounting bracket.

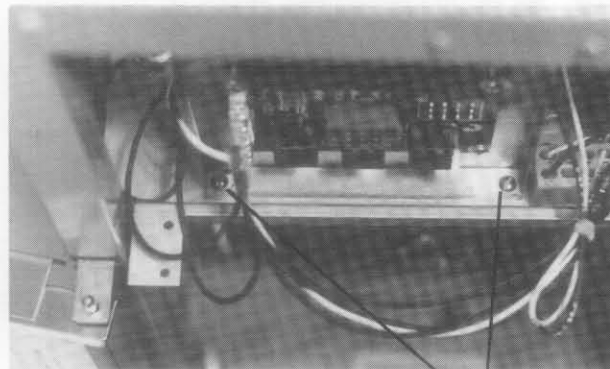
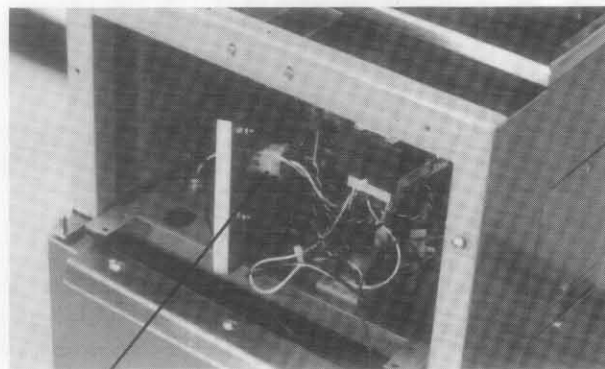

Figure 15

SCREWS

7. Disconnect 12-pin plug from back of interface board and lay board in left end of compartment with all other wires still connected.



PLUG

Figure 16

8. Remove the 12-volt transformer from the control shield and lay in left end of compartment with wires still connected.

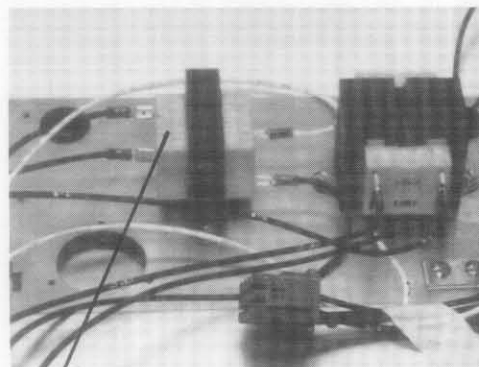

TRANSFORMER

Figure 17

- Remove temperature sensing probe wires from 12-pin plug removed in step 7.

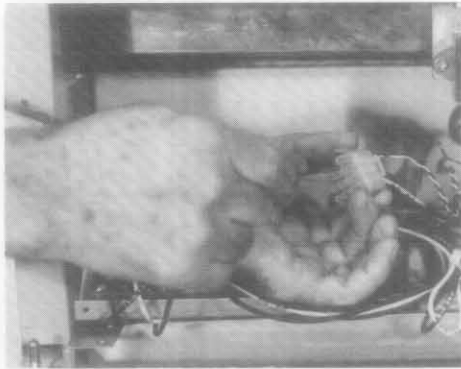

Figure 18

- Unscrew temperature sensing probe from frypot and remove.

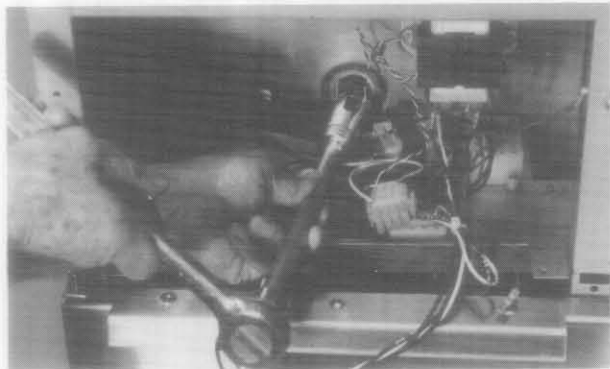

Figure 19

- Apply PST56765 Loctite pipe thread sealant to new probe threads.
- Reverse the above procedures to install replacement probe.

Procedure 3: Replacing Hi-Limit Thermostat — MJ45E or FM45E With Computer or Controller

- Drain shortening below level of hi-limit thermostat.
- Remove two screws from top of controller panel. (See Figure 13.)
- Controller panel is hinged at bottom and will swing open from top.
- Remove wire harness plug from back of controller panel. (See Figure 14.)
- Remove controller panel from hinge slots in panel mounting panel.
- Remove two screws and nuts from base of interface board mounting bracket. (See Figure 15.)

- Disconnect 12-pin plug from back of interface board and lay board in left end of compartment with all other wires still connected. (See Figure 16.)
- Remove pilot generator fitting from gas valve pilot magnet.

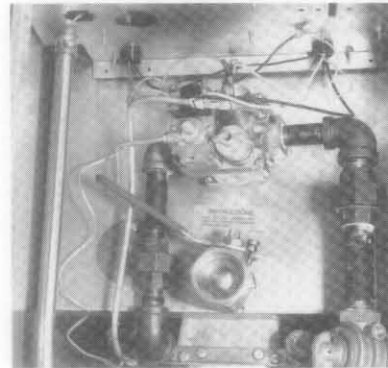

Figure 20

- Remove hi-limit wires from gas valve pilot magnet and pull up through the control shield.

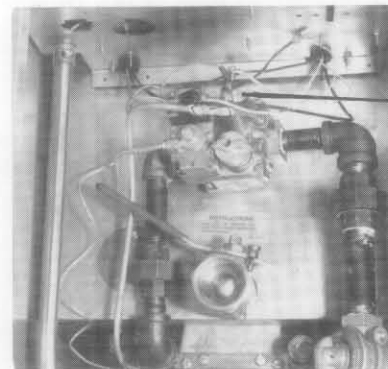

Figure 21

- Unscrew hi-limit thermostat from frypot and remove.

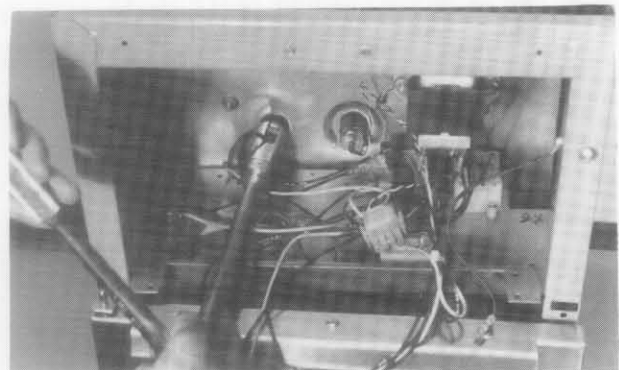

Figure 22

- Apply PST56765 Loctite pipe thread sealant to hi-limit threads.
- Reverse the above procedures to install replacement hi-limit thermostat.

Procedure 4: Replacing Operating or Hi-Limit Thermostats — MJ45E With Thermostat Control

1. Drain shortening below level of operating and hi-limit thermostats.
2. Remove two control panel screws.



SCREWS Figure 23 KNOB

3. Remove thermostat knob and lift control panel off fryer front frame.
4. Unplug control panel wiring harnesses at quick disconnect connectors and retain for reinstallation.

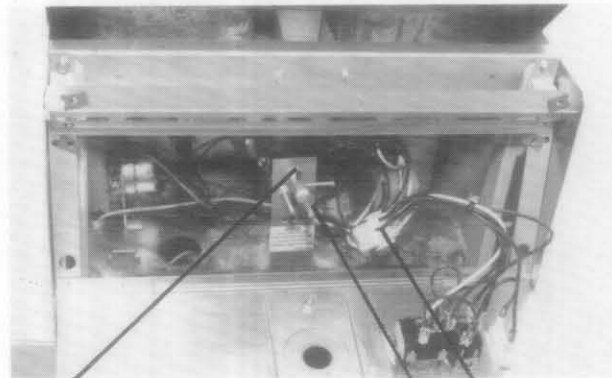

SCREW Figure 24 SHAFT & CONNECTOR

5. Remove solid thermostat extension shaft from end of flexible thermostat shaft using a small allen wrench.
6. Remove flexible shaft from thermostat shaft screw.

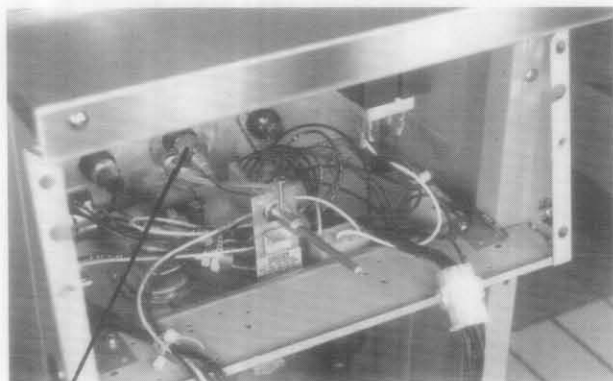

SCREW Figure 25

7. When replacing the operating thermostat, disconnect both wires from gas valve and 20-hole terminal block.
8. When replacing the hi-limit thermostat, remove the molded hi-limit thermostat wire adapter from the Unitrol Gas valve pilot magnet.

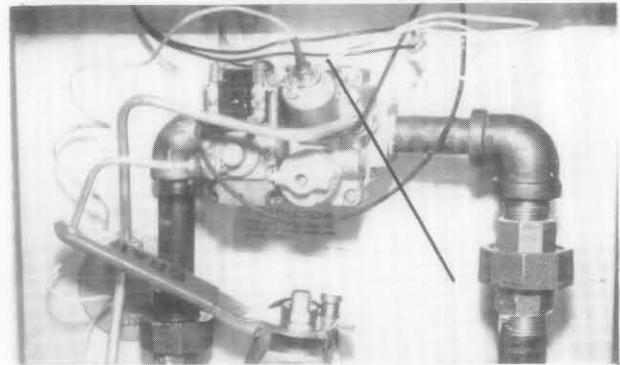

Figure 26

9. Unscrew the operating thermostat or hi-limit from fitting in frypot front wall and remove from fryer.

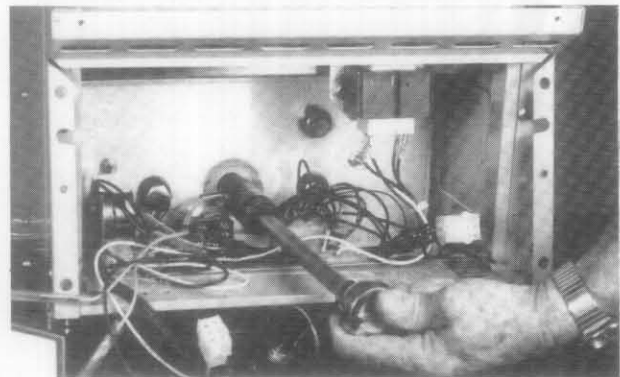

Figure 27

10. Apply PST56765 Loctite pipe thread sealant to threads of replacement thermostat before installation.
11. Reverse the above procedure to install operating or hi-limit thermostat.

CAUTION:
DO NOT OVER TORQUE

NOTE: The operating thermostat must be calibrated after installation is complete. (See Procedure 5 for calibration instructions.)

Procedure 5: Calibrating Thermostat After Installation (for MJ45E With Thermostat Control)

NOTE: The fryer control panel must be hinged down from the control panel mounting frame to perform thermostat calibration.

1. Fill the frypot to the OIL-LEVEL LINE with shortening. If solid shortening is used, it must be premelted before starting calibration procedure.

2. Ensure fryer ON/OFF switch is in the OFF position, then light the pilot light (See Lighting Instructions).
3. Insert a good grade mercury thermometer or pyrometer in frypot center 2 to 3 inches (50 to 75mm) deep.

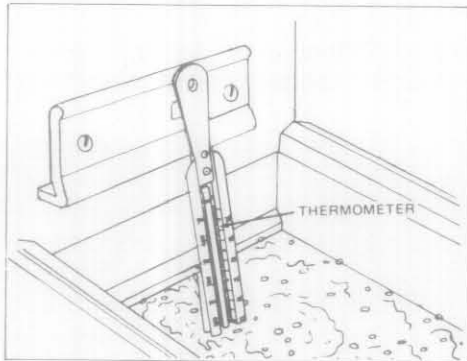

Figure 28

4. Turn fryer gas valve to the ON position. (See Figure 5, Page 6.)
5. Turn fryer ON/OFF switch to ON position.
NOTE: If the burner does not light at this time, this does not mean the thermostat is defective. Recheck the wiring, then slowly turn the thermostat adjusting screw counterclockwise until the burner lights. Turning the adjusting screw counterclockwise causes the burner to light and clockwise causes it to shut off.
6. When the shortening temperature reaches 325°F (162°C), turn the thermostat adjusting screw clockwise until the burner shuts off.
7. Allow the fryer to set for a few minutes, then slowly turn the thermostat adjusting screw counterclockwise until the burner lights.

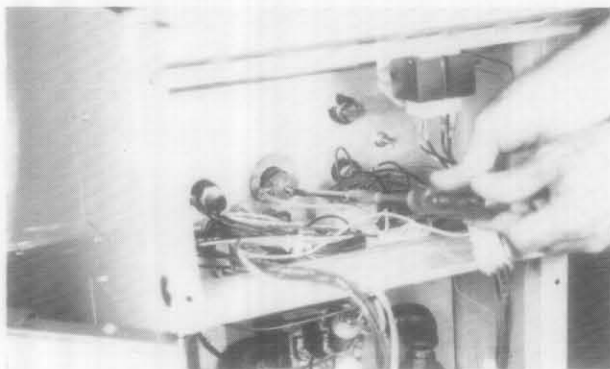

Figure 29

8. Repeat Steps 6 and 7 above until the desired 325°F (162°C) temperature is obtained. **NOTE:** A good calibration point is halfway between the lowest and highest temperature dial readings. That reading being at the 12 o'clock position. The fryer is said to be in calibration if the burner lights at the calibration point as the shortening temper-

ature drops — not when the burner shuts off as the temperature rises.

9. Once the calibration point of 325°F (162°C) is reached, the burner should be allowed to cycle on and off at least 3 times to be sure it will light at the calibrated temperature.
10. After the thermostat calibration is complete, turn off the fryer power ON/OFF switch and disconnect the fryer power cord.
11. Install the thermostat flexible extension on thermostat shaft screw and be sure the set screws are tight.
NOTE: The thermostat adjusting screw must not be moved while installing the flexible extension shaft.
12. Install the solid metal extension shaft on the end of the flexible thermostat extension shaft with the stop pin at the 12 o'clock position. Ensure the stop pin and set screws are tight to prevent slippage.

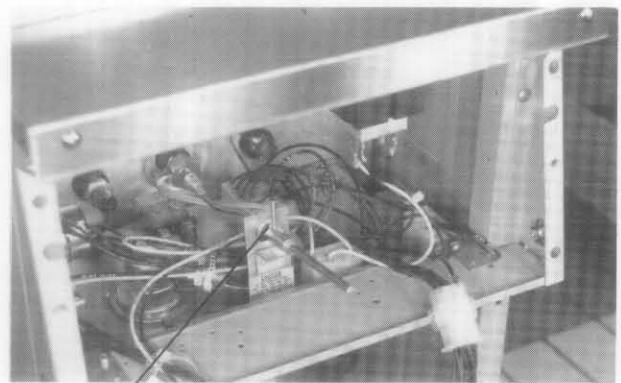

Figure 30

13. Install and secure the fryer control panel being careful to route the solid metal shaft through the temperature dial plate.
14. Before installing the thermostat knob, loosen the temperature dial plate screws and rotate the dial until the 325°F (162°C) mark is at the 12 o'clock position, then tighten the screws.



Figure 31

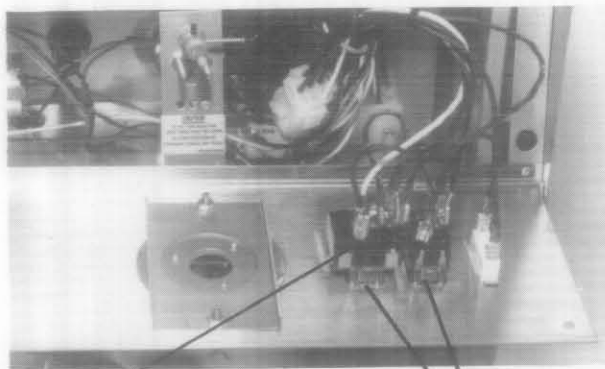

Figure 32

15. Install the thermostat knob with its pointer pointing at 325°F (162°C) on the temperature dial plate. Tighten the thermostat knob set screws to prevent slippage.

Procedure 6: Replacing Power or Melt Switch (for MJ45E With Thermostat Control)

1. Remove two control panel screws. (See Figure 23.)
2. Remove thermostat knob and lift control panel off fryer front frame.
3. Unplug control panel wiring harness at quick disconnect connectors and retain for reinstallation. (See Figure 24.)
4. Unsnap switch chrome bezel from rear of switch and push switch through front of control panel.
5. If equipped, the melt switch and ON/OFF switch must be removed from rear side of control panel after unsnapping chrome bezel from rear side of switch.



SWITCH Figure 33 BEZEL

6. Remove wire terminals one at a time and connect to replacement switch until all wires are transferred.
7. Reverse above procedure to reassemble.

Procedure 7: Replacing Control Panel Indicator Lights (for MJ45E With Thermostat Control)

1. Remove two control panel screws. (See Figure 23.)
2. Remove thermostat knob and lift control panel off fryer front frame.
3. Unplug control panel wiring harness at quick disconnect connectors and retain for reinstallation.

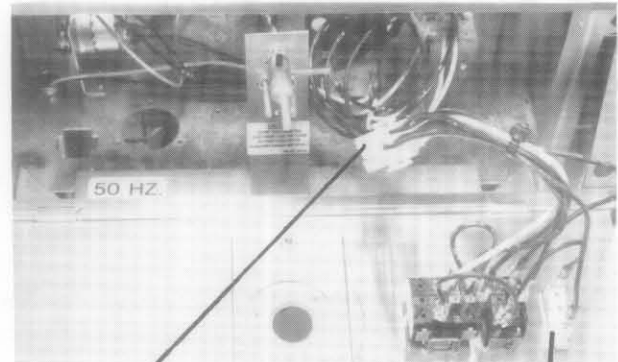

QUICK DISCONNECT Figure 34 INDICATOR LIGHT

4. Push light through front of control panel and remove one wire terminal at a time and connect to replacement light until all wires are transferred.
5. Reverse above procedure to reassemble.

Procedure 8: Replacing Melt Cycle Timer (for MJ45E With Thermostat Control)

1. Remove two control panel screws. (See Figure 23.)
2. Remove thermostat knob and hinge control panel down.
3. Remove melt timer motor mounting screws.



SCREWS Figure 35

4. Remove one wire at a time and connect to the replacement timer until all wires have been transferred.

5. Reverse above procedure to reassemble.

Procedure 9: Replacing Pilot Pressure Switch (for MJ45E Fryers With Thermostat Control Prior to Series AH Only)

1. Turn off fryer Manual gas valve or disconnect gas supply quick disconnect.
2. Remove pilot gas supply tube fittings from pilot pressure switch "TEE" fitting.
3. Remove two control panel screws.
4. Remove thermostat knob and lift control panel off fryer front frame.
5. Unplug control panel wiring harness at quick disconnect connectors and retain for reinstallation.
6. After gaining access to top of the pilot pressure switch, remove three screws that secure the switch to the component mounting plate.
7. Remove pilot pressure switch wires from the fryer latch relay terminals 1 & 5.
8. Lift the pilot pressure switch off the component mounting plate and out of the fryer.
9. Reverse above procedure to install replacement pilot pressure switch.

Procedure 10: Replacing Fryer Latch Relay (for MJ45E Fryer With Thermostat Control Prior to Series AH)

1. Remove two control panel screws.
2. Remove thermostat knob and lift control panel off fryer front frame.
3. Unplug control panel wiring harness at quick disconnect connectors and retain for reinstallation.
4. For easier access to the latch relay, cut wire ties on wire harness leading to the terminals of the relay.
5. Remove the relay mounting screws.
6. Disconnect wires from the latch relay terminals one at a time and connect to same terminals on the replacement relay.
7. Reverse above procedure to install replacement ring.

Procedure 11: Replacing Electrical Components on Control Shield — Fryers With or Without Computer

1. Remove two screws from top of controller panel. (See Figures 13 & 23.)
2. Controller panel is hinged at bottom and will swing open from the top.
3. Remove wire harness plug from back of controller panel. (See Figures 14 & 24.)
4. Remove electrical wires and mounting screws from the particular component to be replaced.

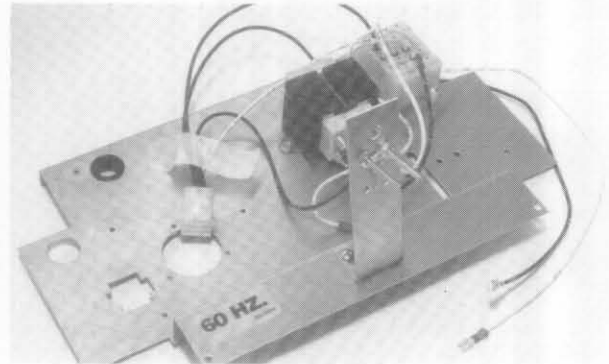

Figure 36

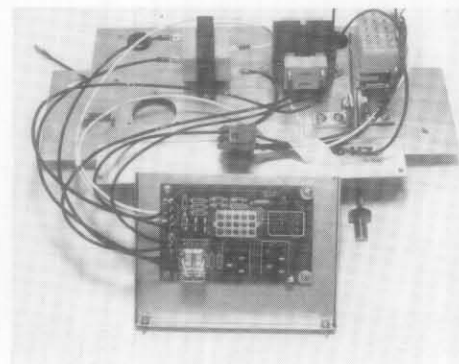
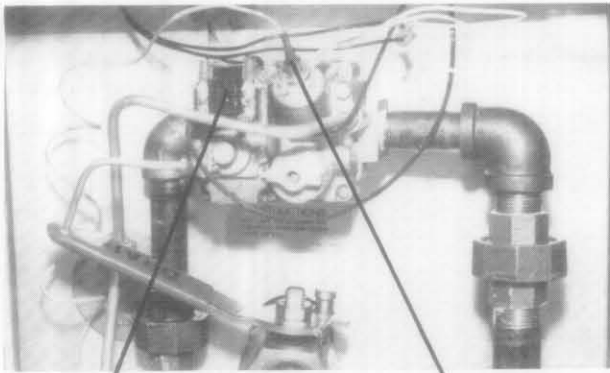

Figure 37

5. Reverse the preceding procedures to install replacement components on the control shield.

Procedure 12: Replacing Fryer Gas Valve

1. Turn the fryer manual gas valve off if equipped.
2. Disconnect wires from gas valve terminal block. Mark wires to facilitate reinstallation.



TERMINAL BLOCK Figure 38 PILOT GENERATOR

3. Remove pilot generator fitting and hi-limit thermostat wires from gas valve pilot magnet.

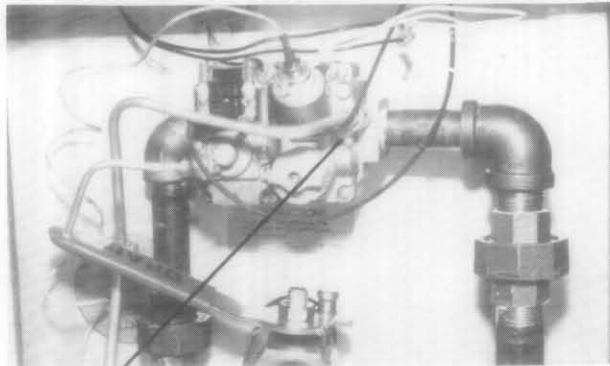

PILOT FITTING Figure 39

4. Remove pilot gas line fitting from gas valve.

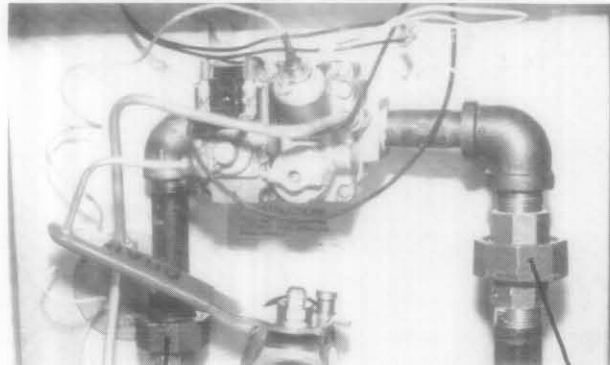

Figure 40

5. Remove pipe union collars at left and right of gas valve (on Filter Magic fryers), loosen pipe union collar at left and compression fitting at right of gas valve.

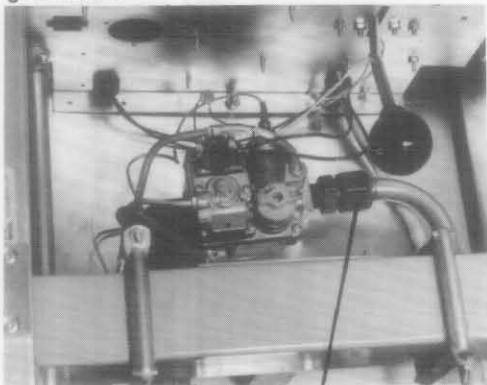

Figure 41

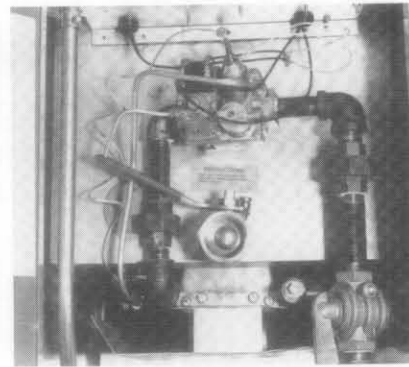

Figure 42

6. Remove gas valve.

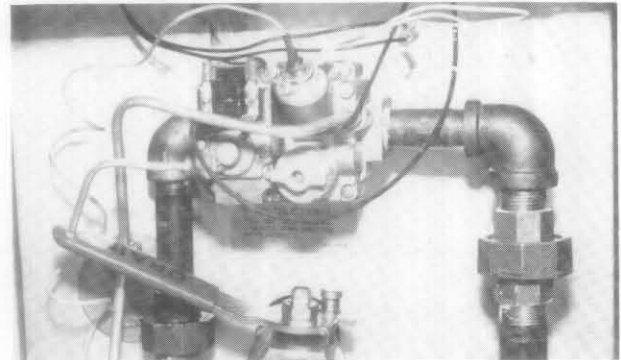

Figure 43

7. Remove pipe fittings from old gas valve and install on replacement valve. Apply PST56765 Loctite pipe thread sealant to threads.

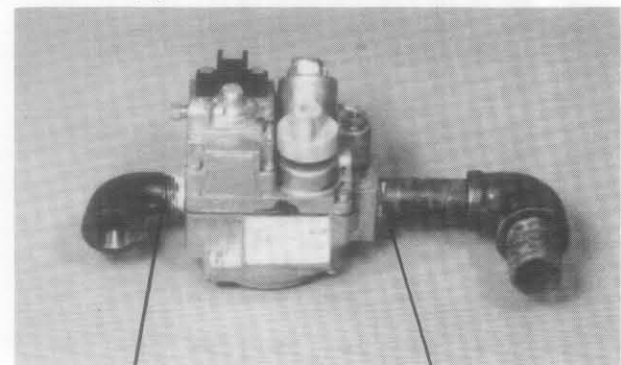
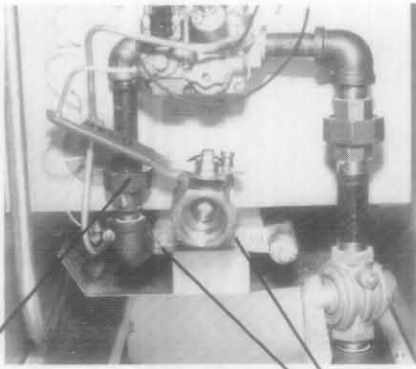

Figure 44

8. Reverse above procedure to install replacement gas valve.

Procedure 13: Removing Main Burner Assembly

1. Turn fryer manual gas valve off if equipped.
2. Remove pipe union collar at left side of gas valve.



UNION Figure 45 SCREWS

3. Remove the pilot generator fitting from gas valve. (See Figure 38.)
4. Remove burner heat shield hanger screws at front of main burner and remove heat shield. (See Figure 45.)
5. Remove main burner hanger screws. (See Figure 45.)
6. Lower front of main burner, pull forward to clear rear burner hanger, and lower to floor. (On single basket lift fryers, the gas supply line under the burner must be removed before the burner can be lowered to the floor.)

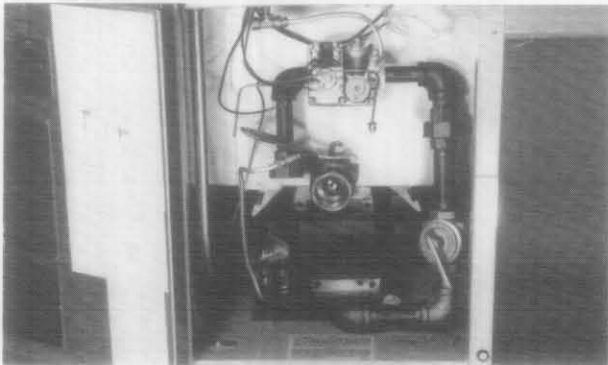

Figure 46

7. Raise the fryer(s) enough to slide main burner from under the fryer(s) cabinet.
8. Reverse the preceding procedures to reinstall main burner.

Procedure 14: Replacing Pilot Burner

1. Turn the fryer manual gas valve off.
2. See Procedure 13 (Remove Main Burner Assembly).
3. Remove pilot tubing from bottom of pilot assembly.

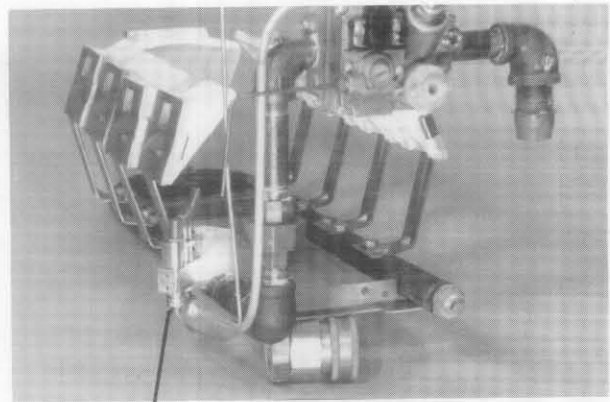
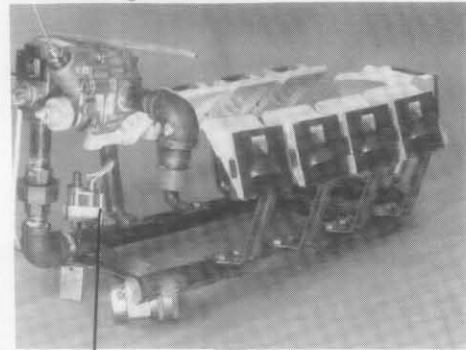

Figure 47

4. Bend clip at bottom of pilot burner and remove generator.
5. Remove two pilot burner mounting screws from pilot mounting bracket.



SCREWS Figure 48

6. Pilot burner may now be removed for cleaning or replacement.
7. Reverse above procedure to install replacement pilot burner.

Procedure 15: Replacing Pilot Generator

1. Bend pilot generator clip at bottom of pilot burner.

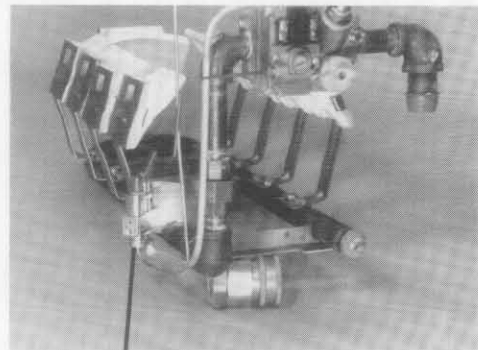

Figure 49

2. Remove pilot generator from the pilot burner.
3. Remove pilot generator fitting from gas valve pilot magnet. (See Figure 38.)

NOTE: Some difficulty may be encountered in gaining access to the pilot burner. Easier access may be obtained by referring to Procedure 13.

- Reverse the above procedure to install replacement pilot generator.

Procedure 16: Replacing Hi-limit Thermostat Wire Adapter

- Remove pilot generator electrical fitting from Unitrol gas valve pilot magnet.
- Lift the molded plastic wire adapter assembly and wires out of the pilot magnet.

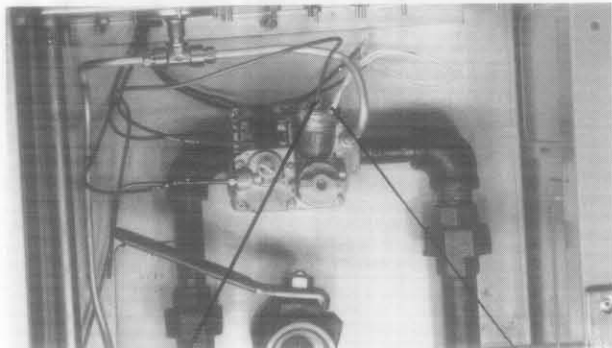

Figure 50

- Cut inline splices from the wire adapter and hi-limit thermostat wires.

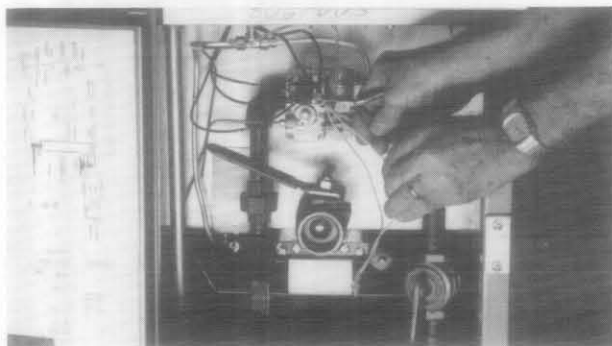

Figure 51

- Strip wire insulation from end of the hi-limit wires and splice on a new hi-limit thermostat wire adapter assembly.
- Insert the new molded plastic wire adapter into the Unitrol gas valve pilot magnet.
- Screw the pilot generator electrical fitting into the gas valve pilot magnet finger tight then 1/8 turn more with a small wrench.

Procedure 17: Replacing Burner Ceramic Target

- Turn fryer manual gas valve off if equipped.
- Refer to Procedure 13 (Remove Main Burner Assembly).
- Unlock the ceramic target locking tab with needle nose pliers or screwdriver, slide the ceramic target up off the deflector.

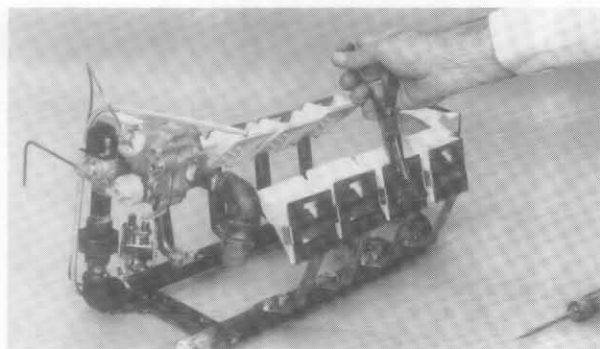

Figure 52

- Reverse the above procedure to install replacement ceramic target.

Procedure 18: Replacing Burner Ceramic Target and Deflector

- Turn fryer manual gas valve off if equipped.
- Refer to Procedure 13 (Remove Main Burner Assembly).
- Using a 1/2 in. box end wrench or socket and ratchet, remove the two brass orifices that hold the target bracket to the burner manifold.

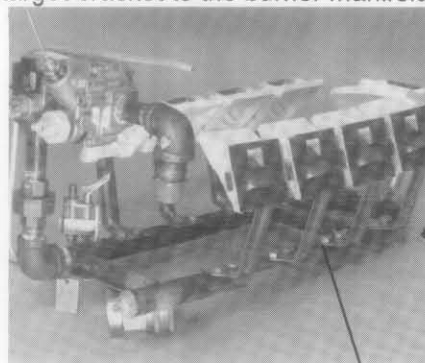

Figure 53

- Reverse the above procedure to install replacement ceramic target and deflector.

NOTE: Use extreme CAUTION to prevent cross threading and stripping when reinstalling the brass orifices.

Procedure 19: Alignment & Adjustment of Burner Ceramic Target and Deflector Assemblies

- Proper alignment of all burner targets should be 3/4 in. between top edge of ceramic targets and wall of frypot.

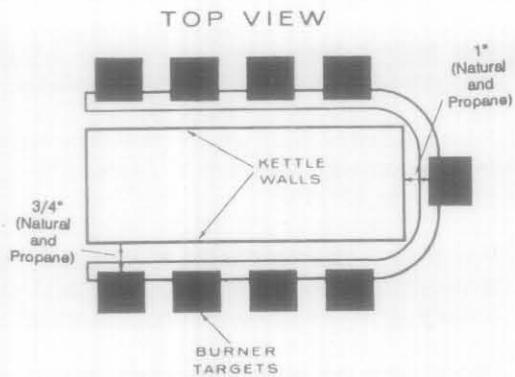

Figure 54

2. To adjust targets, bend the deflector brackets away or toward the frypot to obtain the 3/4 in. measurement.

Procedure 20: Replacing The Frypot

1. Drain all shortening from frypot.
2. Disconnect fryer from gas and electrical power supply.
3. If equipped, remove frypot covers, external computer probe, and basket hangers or basket lift arms.
4. Remove screws from top cap above control panel and lift up and off the fryer(s).

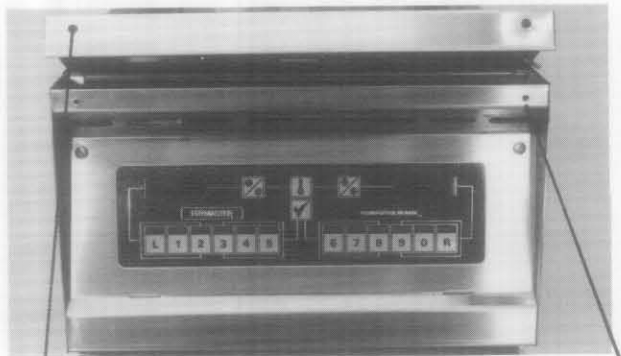

Figure 55

5. Refer to Procedure 1 and remove computer, or solid-state controller.
6. For fryers equipped with thermostat control, remove thermostat knob.
7. Computer or control panel is hinged at bottom and will swing open from top.
8. Remove wire harness plug from back of computer or control panel. (See Figures 14 and 24.)
9. Remove computer or control panel from hinge slots in control panel mounting frame.
10. Remove louvered frame above control panel opening.



Figure 56

11. For fryers equipped with computer or solid-state controller, remove two screws and nuts from base of interface board bracket. (See Procedure 2, Step 6.)
12. Disconnect 12-pin plug from back of interface board and remove temperature probe and hi-limit wires from plug with pin removal tool.

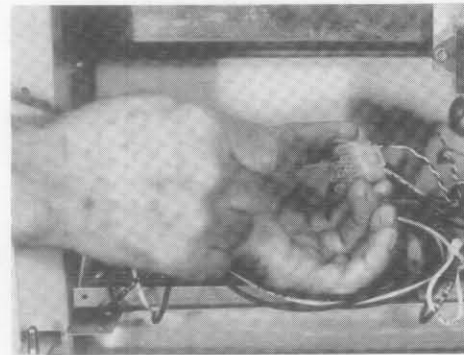

Figure 57

13. Lay interface board and bracket loosely on top of control shield with wires still connected.
14. For fryers equipped with thermostat, remove thermostat flexible shaft from thermostat adjusting screw. (See Procedure 4, Step 6.)
15. Remove two screws and nuts from thermostat shaft bracket and lift thermostat flex shaft and bracket out of control shield.

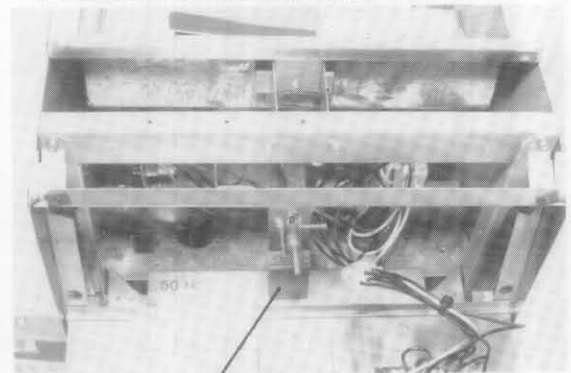

Figure 58

16. For fryers equipped with pilot pressure switch, remove pilot gas tubes from pressure switch tee fitting.

17. For fryers equipped with Filter Magic system, remove oil return valve linkage at front pivot point.

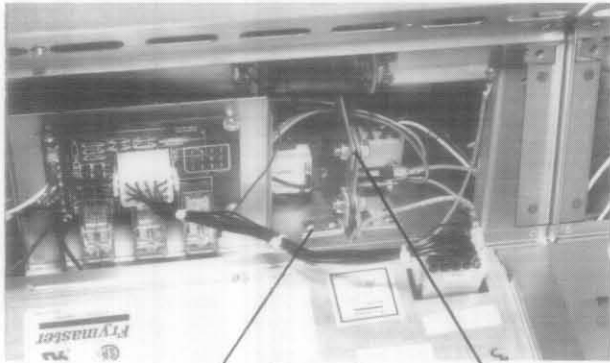

Figure 59

18. Remove screws and nuts from filter handle pivot brackets.
19. Remove two screws and nuts from front of control shield where attached to control panel frame.

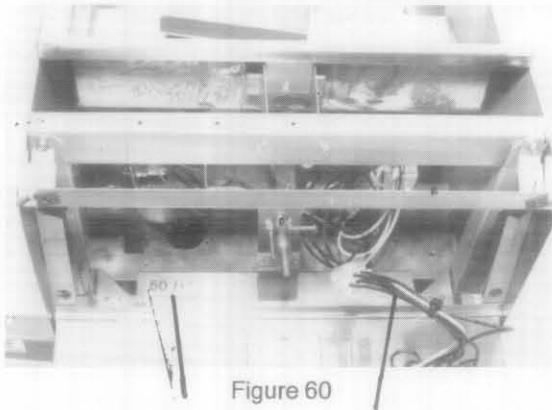

Figure 60

20. Remove nut from rear flange under control shield where attached to front of frypot.

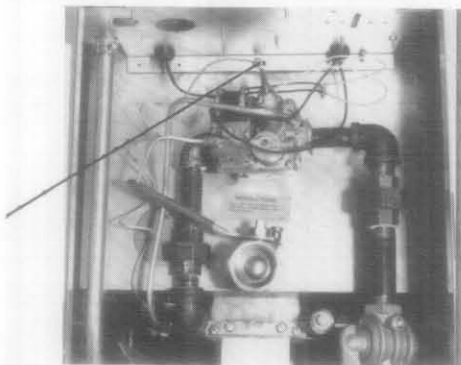

Figure 61

21. For fryers equipped with power input conduit at left rear corner of control shield, remove conduit retaining nut and slip shield up off conduit. Remove wires in conduit from components and mark.
22. Remove pilot generator fitting from gas valve pilot magnet and lift hi-limit thermostat wire adapter from slot. (See Procedure 3, Step 8.)

23. Pull hi-limit thermostat wires and adapter up through grommet at rear of control shield.
24. Remove wires from gas valve terminal block. Mark each wire for ease of reconnection. (See Procedure 12, Step 2.)
25. For fryers equipped with thermostat, remove thermostat wire from gas valve and pull up through grommet at rear of control shield.
26. Disconnect the other thermostat wire from 20-hole terminal block. Mark for ease of reconnection.

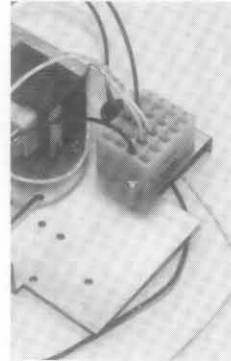

Figure 62

27. For fryers equipped with safety drain switch, remove cover from switch box and remove wires from switch. Pull wire terminals through switch box.
28. Pull up and forward on front of control shield to clear rear mounting stud on front of frypot.
29. Rotate right side of control shield up and to the left and remove from control panel opening. NOTE: Some difficulty may be encountered in removing control shield from opening. NOTE: Fryers equipped with power input conduit at left rear corner of control shield, the wires must be pulled through control shield as shield is removed from control panel opening.
30. Remove pipe union from right side of fryer gas valve (fryers without filter system).

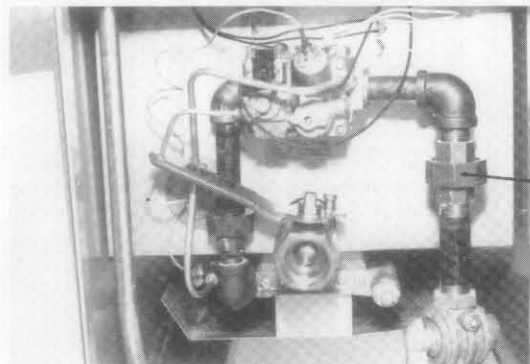

Figure 63

31. Remove gas tube compression fitting from right side of gas valve (fryers with filter system). (See Figure 41.)

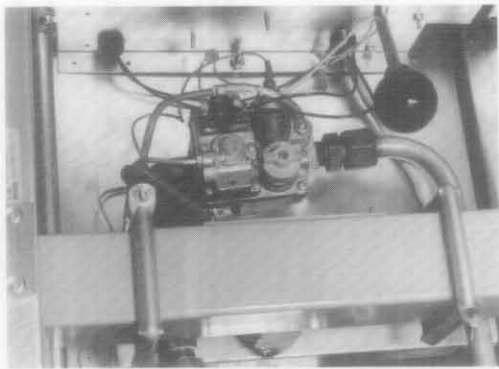

Figure 64

32. For fryers with square drain system, remove the section of square drain from the drain valve of the frypot to be removed.

33. Remove the frypot hold-down bracket.

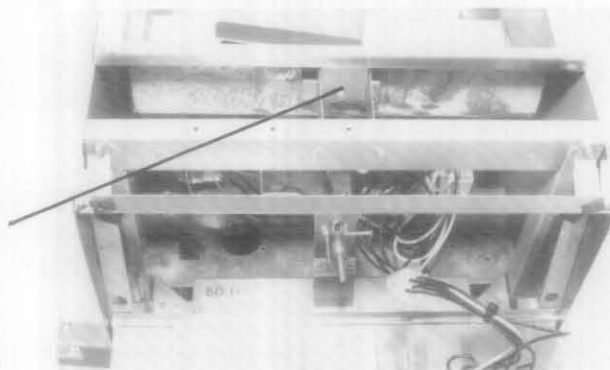

Figure 65

34. Remove screws from flue cap sides and back and lift off of fryer(s). NOTE: If frypot to be removed is in a battery of two or three, the whole two or three battery flue cap must be removed.

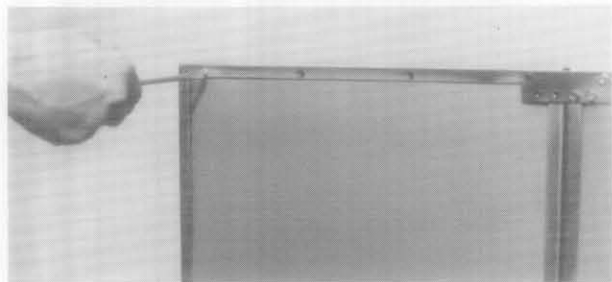

Figure 66

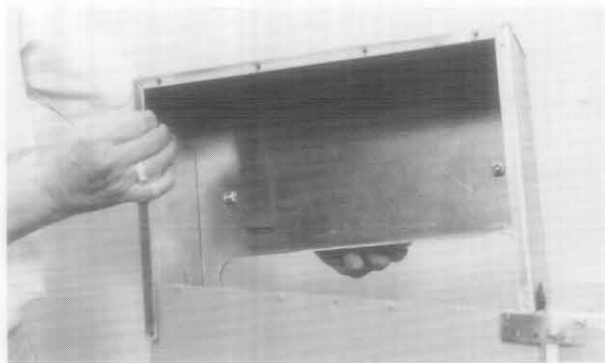

Figure 67

35. For fryer(s) equipped with filter system, remove oil return hoses or lines from front of frypot.

36. Lift frypot complete with burner, gas valve, flue, drain valve, and combustion chamber from fryer cabinet. NOTE: After lifting frypot partially out of cabinet, tilt front downward to allow drain valve to pass by cabinet top, front crossbar.



Figure 68

37. Transfer burner heat shield and burner to replacement frypot.

38. Remove drain valve, hi-limit thermostat, operating thermostat or temperature probe and transfer to replacement frypot. NOTE: Before installing thermostats, probes and drain valve on replacement frypot, clean threads and apply Loctite PST 56765 thread sealant to threads.

39. Reverse the preceding steps to install replacement frypots.

Procedure 21: Adjustment of Pilot Flame

1. Pilot must be lit to make adjustment.
2. Remove cap from pilot adjustment screw hole on gas valve.

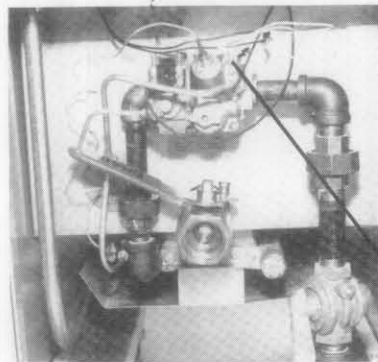

Figure 69

3. Using a small tip screwdriver, turn the pilot adjusting screw counterclockwise to obtain pilot flame of 1- 1-1/2 in. long. To decrease length of pilot flame, turn the screw clockwise.
4. Reinstall the pilot adjustment hole cap when required flame size is obtained. (See Figure 70.)

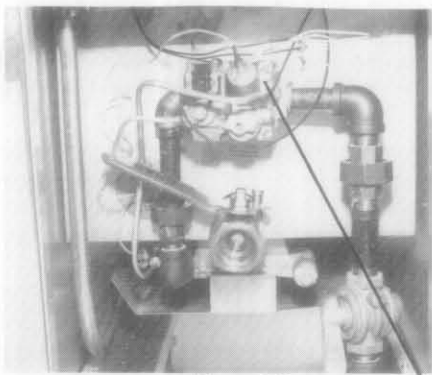

Figure 70

Procedure 22: Burner Gas Pressure Adjustment

1. Obtain a good quality Water Manometer or Water Column Pressure Gauge.

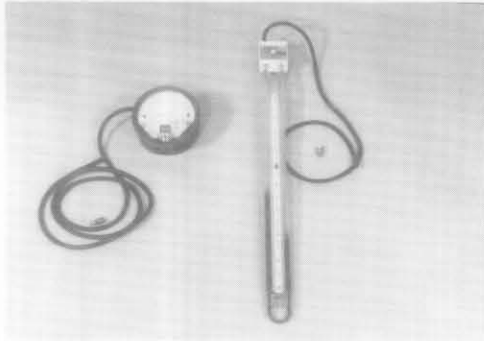

Figure 71

2. Turn gas valve knob to pilot position. (See Figure 3.)
3. Remove pressure tap plug from end of burner manifold.

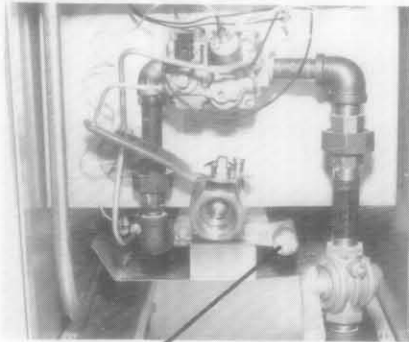

Figure 72

4. Install fitting furnished with manometer or pressure gauge into burner manifold pressure tap hole and attach manometer hose to fitting.

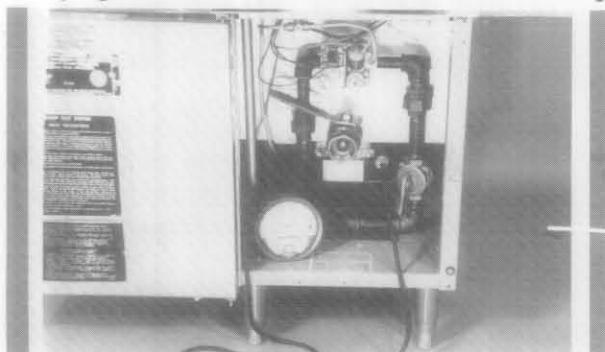

Figure 73

5. Remove cap from gas valve regulator adjustment screw.

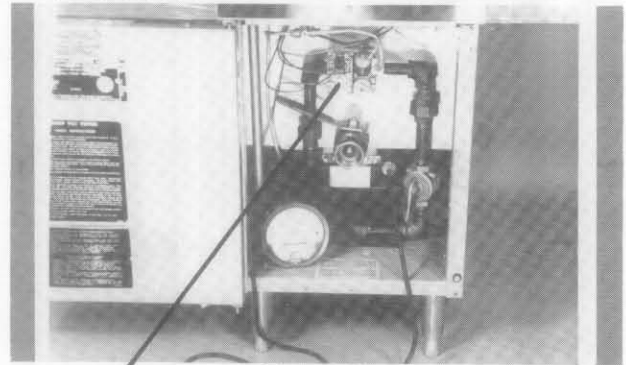

Figure 74

6. Turn gas valve knob to ON position. (See Figure 5.)
7. For fryers equipped with computer, switch fryer on and allow burner to cycle on and off until temperature of liquid in frypot reaches 180°F (83°C). The burner will come on and remain on for a longer period of time.
8. For fryers equipped with thermostat, switch fryer on and melt switch off. The burner will come on and remain on long enough to perform Step 9 and 10.
9. Monitor the gas pressure reading on the manometer or pressure gauge.
10. Adjust the gas valve regulator adjustment screw to obtain burner manifold pressure as follows:
Natural Gas — 3.5 inches W.C. (0.86 kPa) LP Gas 8.25 inches W.C. (2.05 kPa)

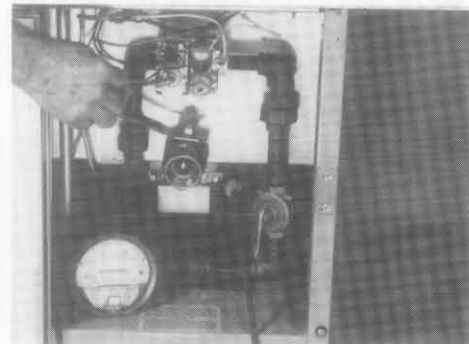

Figure 75

11. Install gas valve regulator cap screw when specified manifold pressure is obtained.
12. Switch fryer off, remove manometer fitting from manifold tap hole, and reinstall pressure tap plug.

Procedure 23: Replacing Filter Pan Tube Heater

1. Remove tube cover and disconnect heater wires.

2. Turn pan upside down and remove base including casters.
3. Remove foam insulation, foil tape, and old heater. (See Figure 76.)
4. Attach new heater to pan suction tube with a piece of foil tape at starting point. (See Figure 76.)

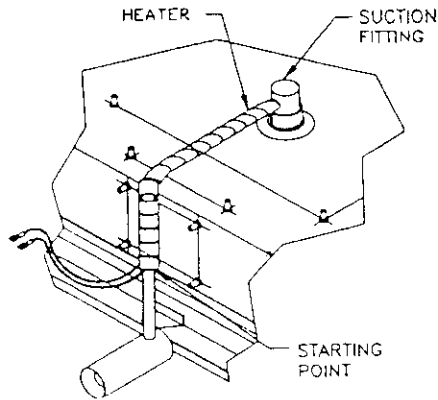

Figure 76

5. Wrap heater around pan suction tube toward suction fitting in a spiral pattern. (See Figure 76.)

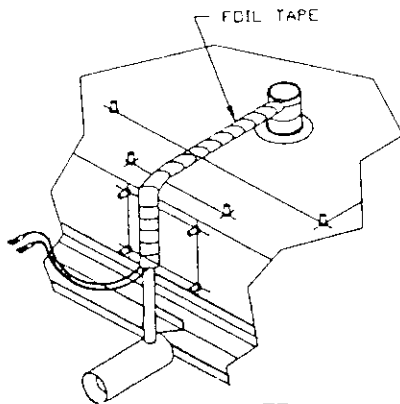

Figure 77

NOTE: The heater must be wrapped tightly around the tube. DO NOT overlap.

6. Wrap the tail end of the heater around suction fitting 2 times and secure with foil tape.
7. Position the heater wires at front of tube and wrap foil tape around heater, tube, and suction fitting overlapping the tape. (See Figure 77.)

NOTE: Make sure no parts of the heater, tube and suction tube are showing after wrapping with foil tape.

8. Wrap tube and suction fitting with foam insulating tape and secure with tie wraps. (See Figure 78.)

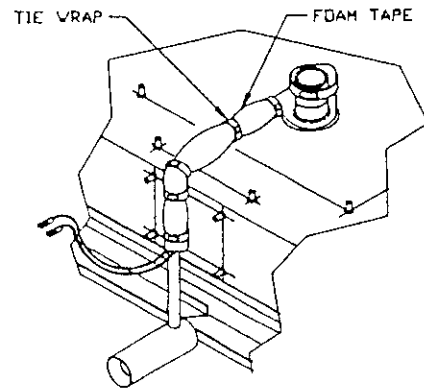

Figure 78

9. Reverse steps 1 and 2 to reassemble base and tube cover to filter pan.
10. Seal all cracks and seams around tube cover and filter pan base with silicone rubber.

17. PREVENTIVE MAINTENANCE

1. **CLEAN GAS VALVE VENT TUBE** — Every 6 Months

To clean the gas valve vent tube, unscrew the vent tube fitting from the gas valve and remove the tube. Insert a piece of ordinary binding wire or piano wire through the vent tube to remove any obstruction. Remove the clean-out wire and blow through the tube. Reinstall the vent tube with the open end pointing down toward the floor.

2. **CLEANING INSIDE AND OUTSIDE OF FRYER**

To clean inside of frypot, see **BOIL-OUT INSTRUCTIONS** in **SECTION 4** of this manual. To clean inside of fryer cabinet, use a dry, clean cloth and wipe all accessible metal surfaces and components to remove accumulated film of shortening and dust. To clean outside of fryer, use a clean, damp cloth soaked with dishwashing detergent and wipe clean of all shortening, dust, and lint. Rinse with a clean, damp cloth.

3. **CHECK BURNER MANIFOLD PRESSURE** — Every 4 to 6 Months

To check the burner manifold pressure, REFER to **Service Procedure 21** in this manual.
3.5 inches W.C. (0.86kPa) NATURAL GAS
8.25 inches W.C. (2.05kPa) LP GAS

Only qualified personnel should accomplish this procedure. To check the burner manifold pressure, ensure that the gas valve knob is turned to the **PILOT** position, then refer to **Service Procedure 21** in this manual.

4. **CHECK ALIGNMENT OF BURNER TARGET AND DEFLECTOR ASSEMBLIES** — Every 4 to 6 Months

To align burner target and deflector assemblies, refer to **Service Procedure 18** in this manual.

18. WIRING DIAGRAMS

MJ45E, FM45E WITH COMPUTER OR CONTROLLER WITH BASKET LIFTS (SERIES AG)

PLAN WIRING DIAGRAM
120/24V., 60HZ., 1Ø, 3 WIRE SERVICE
SCHEMA DES CONNEXIONS ELECTRIQUES SERVICE 3 FIL

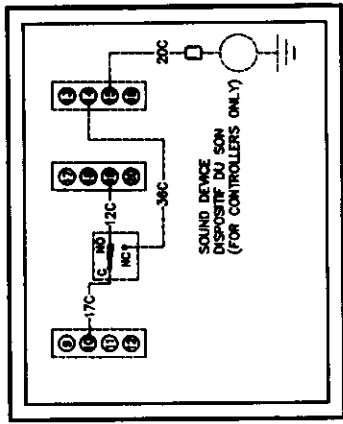
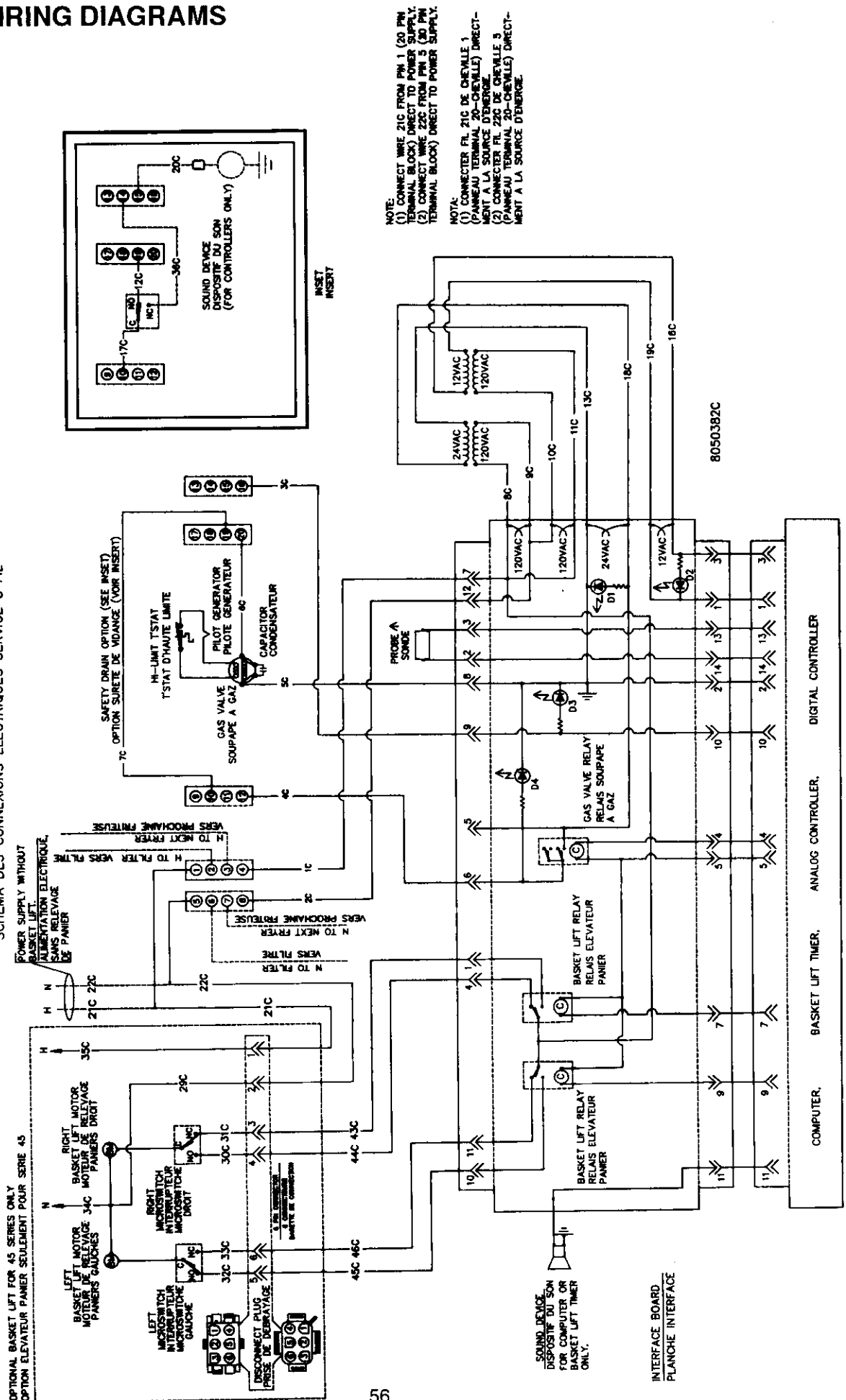

NOTE:
(1) CONNECT WIRE 21C FROM PH 1 (2Ø PH) TO BASKET LIFT OR DIRECT TO POWER SUPPLY.
(2) CONNECT WIRE 22C FROM PH 2 (Ø PH) TO TERMINAL BLOCK) DIRECT TO POWER SUPPLY.
NOTA:
(1) CONNECTER FIL 21C DE CHEVILLE 1 (PANNEAU TERMINAL 2Ø-CHEVILLE) DIRECTEMENT A LA SOURCE D'ENERGIE.
(2) CONNECTER FIL 22C DE CHEVILLE 2 (PANNEAU TERMINAL 2Ø-CHEVILLE) DIRECTEMENT A LA SOURCE D'ENERGIE.

OPTIONAL BASKET LIFT FOR 45 SERIES ONLY
OPTION ELEVATEUR PANIER SEULEMENT POUR SERIE 45

SOUND DEVICE
DISPOSITIF DU SON
FOR COMPUTER OR
BASKET LIFT TIMER
ONLY.

INTERFACE BOARD
PLANCHE INTERFACE

COMPUTER, BASKET LIFT TIMER, ANALOG CONTROLLER, DIGITAL CONTROLLER

8050382C

MJ45E, FM45E WITH STANDARD THERMOSTAT CONTROL WITHOUT BASKET LIFTS (SERIES AG)

PLAN WIRING DIAGRAM: 120V/24V, 60HZ, 1Ø, 3 WIRE SERVICE
240V/24V, 50HZ., 1Ø, 3 WIRE SERVICE

SCHEMA DES CONNEXIONS ELECTRIQUES: 120V/24V, 60HZ, 1Ø, SERVICE DE 3 FILS
240V/24V, 50HZ., 1Ø, SERVICE DE 3 FILS

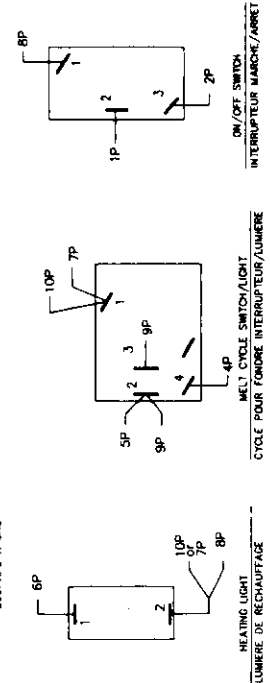
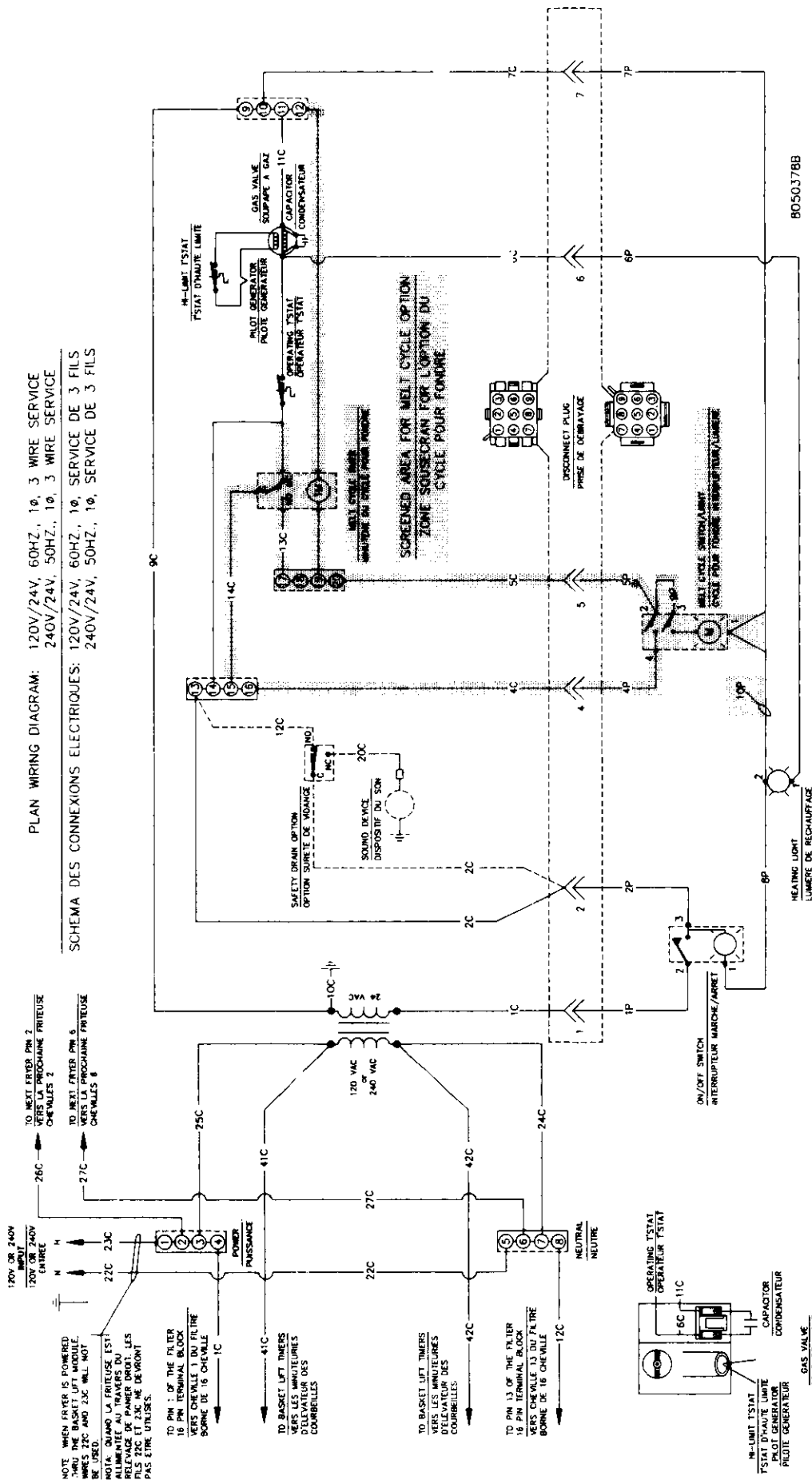

NOTE: WHEN FRYER IS POWERED THROUGH BASKET LIFT MODULE, WIRES 22C AND 23C WILL NOT BE USED.
NOTA: QUAND LA FRITEUSE EST ALIMENTEE PAR LE MODULE DE LIFT, LES FILS 22C ET 23C NE DEVONT PAS ETRE UTILISES.

TO PIN 7 OF THE FILTER 16 PIN TERMINAL BLOCK VERS LES AMPLIIFICATEURS D'ELAVATEUR DES COURBELLES

TO BASKET LIFT TIMERS VERS LES AMPLIIFICATEURS D'ELAVATEUR DES COURBELLES

TO PIN 13 OF THE FILTER 16 PIN TERMINAL BLOCK VERS CHEVILLE 13 DU FAITRE BORNE DE 16 CHEVILLE

ON/OFF SWITCH / INTERRUPTEUR MARCHÉ/ARRÊT

MELT CYCLE SWITCH/LIGHT / CYCLE POUR FONDRE / LUMIERE

HEATING LIGHT / LUMIERE DE RECHAUFFAGE

MJ45E, FM45E WITH COMPUTER C. CONTROLLER AND BASKET LIFTS (PRIOR TO SERIES AG)

PLAN WIRING DIAGRAM SCHEMA DES CONNEXIONS ELECTRIQUES

120V/24V, 60 HZ., 1 Ø, 3 WIRE SERVICE
(COMPUTER, TIMER, BASKET LIFTS)
(ORDINATEUR, MINUTERIE, ELEVEATEURS PANIER)

OPTIONAL BASKET LIFT FOR 45 SERIES ONLY
OPTION ELEVEATEUR PANIER SEULEMENT POUR SERIE 45

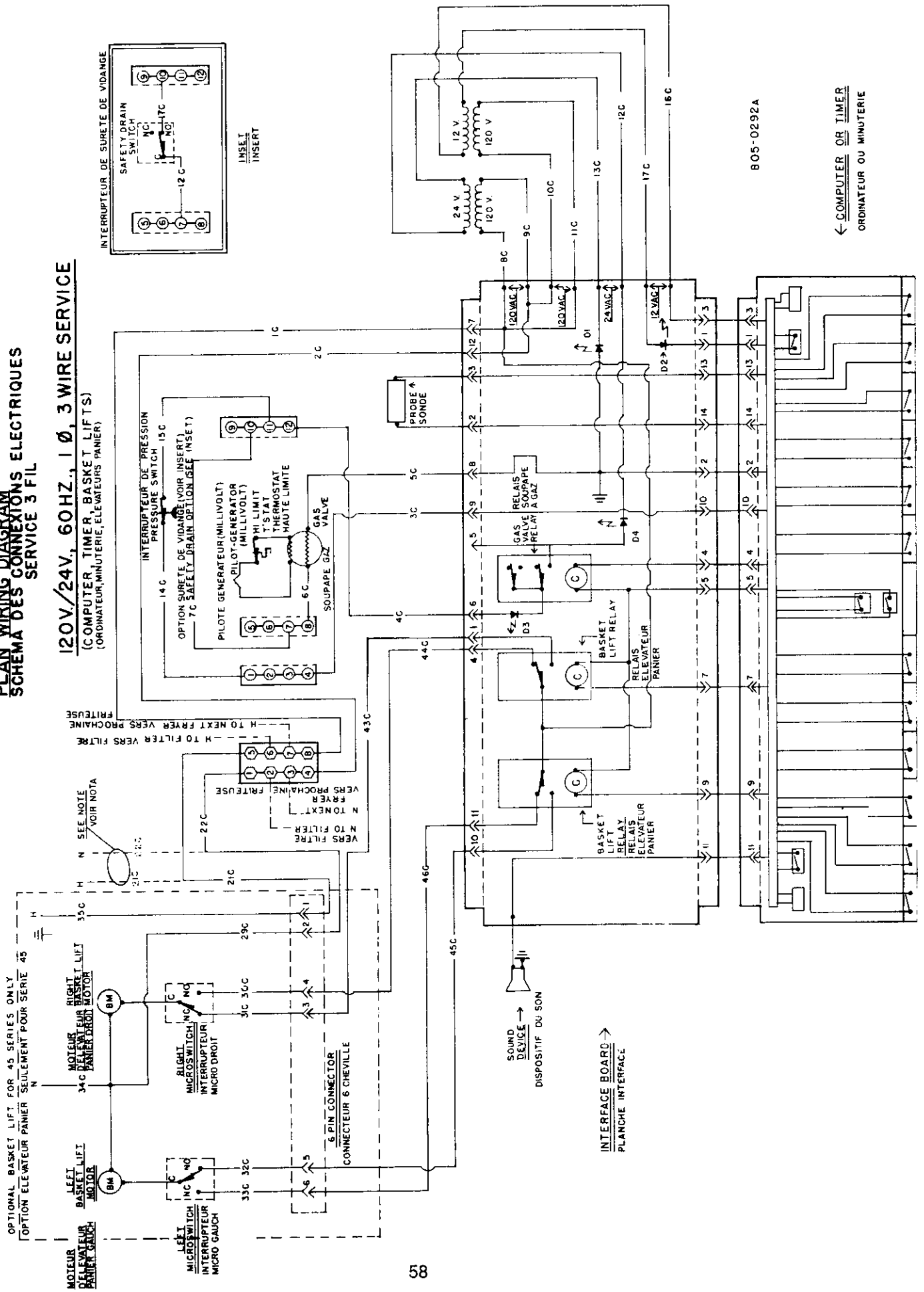

805-0292A

← COMPUTER OR TIMER
ORDINATEUR OU MINUTERIE

**MJ45E, FM45E WITH COMPUTER OR CONTROLLER WITHOUT BASKET LIFTS
(PRIOR TO SERIES AG)**

**PLAN WIRING DIAGRAM SCHEMA DES CONNEXIONS ELECTRIQUES
120V./24V., 60HZ., 1 Ø, 3 WIRE SERVICE SERVICE 3 FIL**

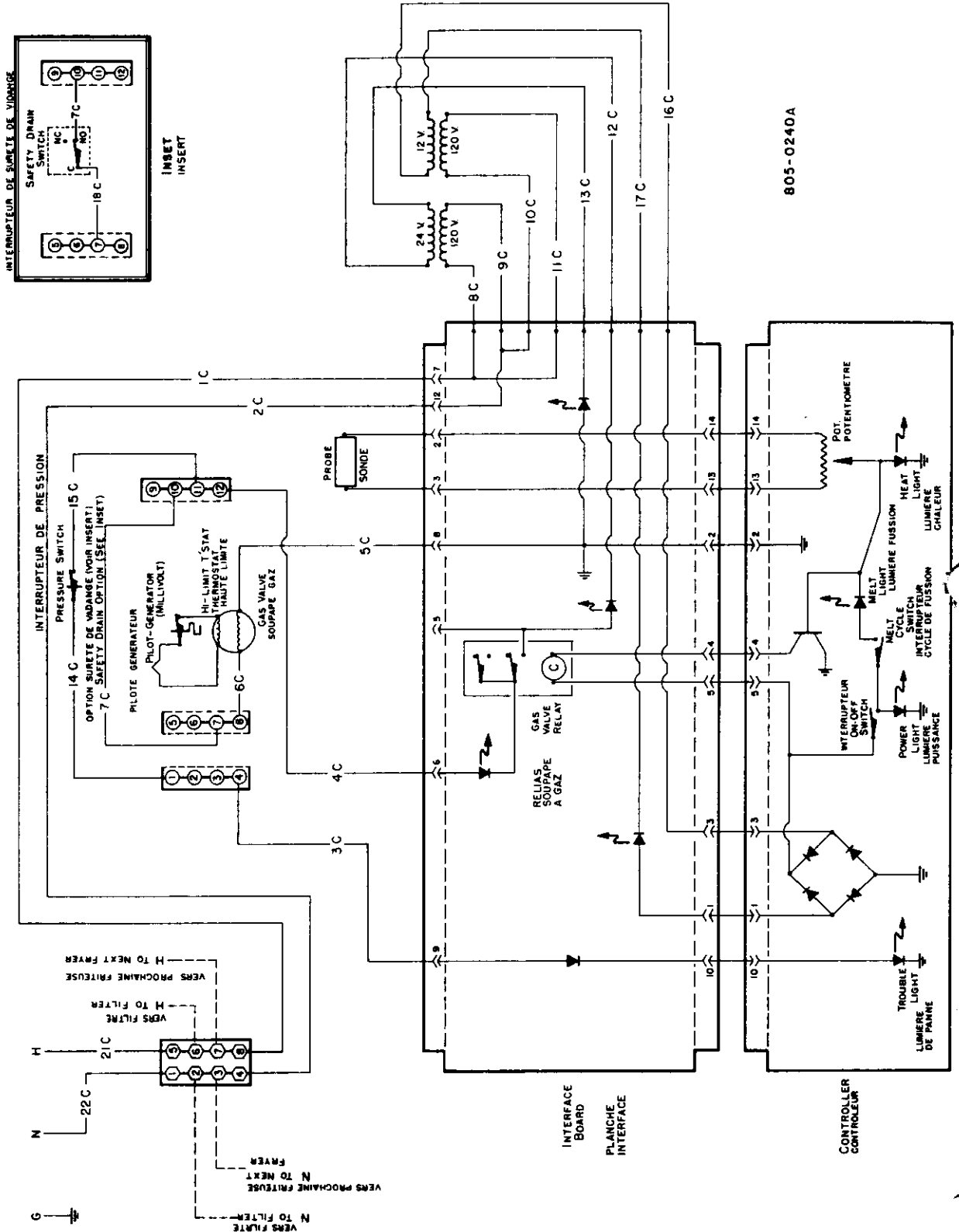

MJ45E, FM45E WITH STANDARD THERMOSTAT CONTROL WITHOUT BASKET LIFTS (PRIOR TO SERIES AG)

PLAN WIRING DIAGRAM 120V/24V, 60HZ, 1Ø, 3 WIRE SERVICE
240V/24V, 50HZ, 1Ø, 3 WIRE SERVICE

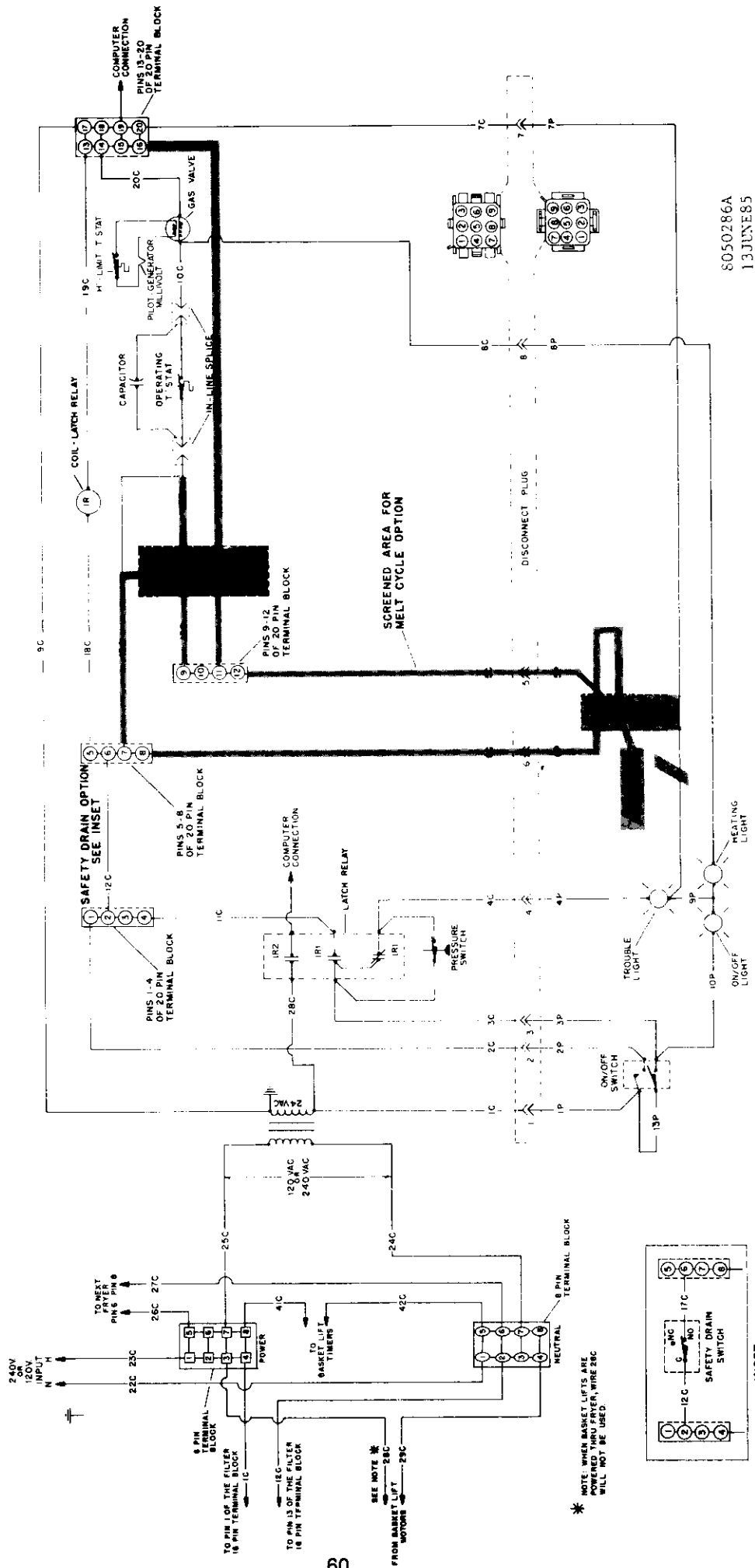

8050286A
13JUNE85

BASKET LIFT SYSTEM WIRING DIAGRAM

PLAN WIRING DIAGRAM SCHEMA DES CONNEXIONS ELECTRIQUES RELEVAGE DES PANIERS

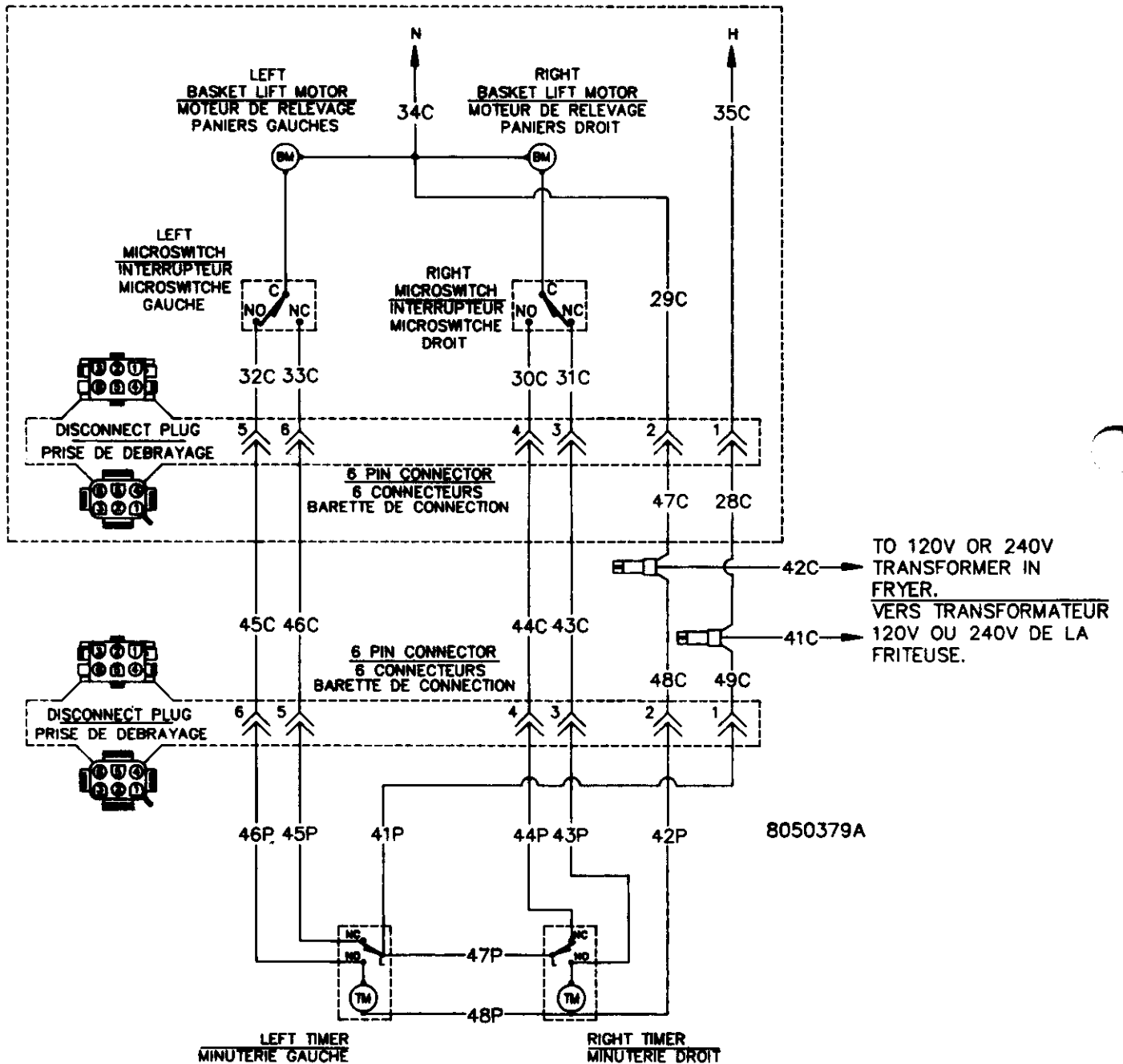

19. INTERFACE BOARD TEST-POINT CHART

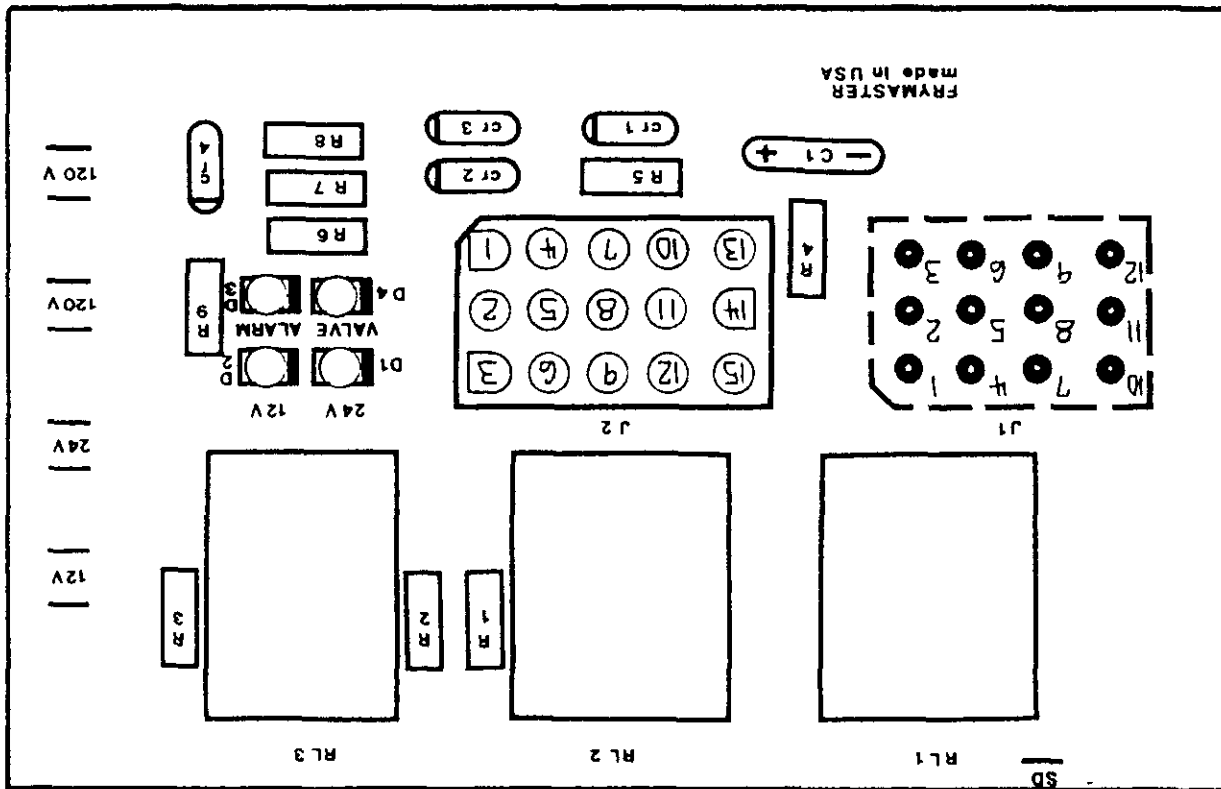

MJ45E & MJCFC COMPUTER MAGIC III

LED D1 - Fryer 24 VAC Power
 LED D2 - Fryer 12VAC Power
 LED D3 - Alarm
 LED D4 - Gas Valve Power 24 VAC

TEST POINTS	TESTING	METER SETTING
1. 1 & 3 of J2 or 12V Terminals Left Side of Board	12VAC Power	50VAC Scale
2. 2 & 3 of J1 or 13 & 14 or J2	*Temperature Probe (With 15-Pin Plus J2 Disconnected)	RX 1000 OHMS
3. 24V Terminals Left Side of Board	24VAC Power	50VAC Scale
4. 7 & 12 of J2 or 120VAC Terminals Left Side of Board	120VAC Power	250VAC Scale
5. 6 of J1 & Grd	24VAC Gas Valve Power LED 4 On	50 VAC Scale

*(OHMS Average Vs. Temperature)

1095 OHMS - Temp. 78°F (26°C)	1602 OHMS - Temp. 325°F (163°C)
1501 OHMS - Temp. 275°F (135°C)	1652 OHMS - Temp. 350°F (176°C)
1551 OHMS - Temp. 300°F (149°C)	1702 OHMS - Temp. 375°F (196°C)
1751 OHMS - Temp. 400°F (204°C)	1771 OHMS - Temp. 410°F (210°C)

(If within + or -5°F (2°C)(8 to 10 OHMS)

20. SPECIFICATIONS

Frymaster

A WELBILT Company

ITEM NO.

MJ45E Gas Fryers

Specifically designed
for high-volume production



Shown with optional casters.

- Open-pot design, no tubes, 3 in. (76 mm) hand clearance, easy to clean
- Centerline thermostat, two-year limited warranty, 7 to 10 second response to loads, 1° anticipating action, no temperature overshoot
- Deep cold zone, 1-1/4 in. (32 mm) IPS ball-type drain valve
- Lifetime limited warranty on stainless frypot
- Dual orifice burner, no burner tube radiants to burn out, no cleaning or adjusting air shutters

The MJ45E has a minimum 40-lbs. (22 litres) and maximum 50-lbs. (27 litres) shortening capacity. The frying area is 14 x 15 in. (356 x 381 mm) at shortening level. This 122,000 BTU model is specifically designed for high-volume frying. The exclusive 1° action thermostat (two-year limited warranty) anticipates rapid rate of temperature rise, eliminating temperature overshoot, extending shortening life and producing a more uniformly-cooked product. Centerline thermostat mounting permits quick sensing (7 to 10 seconds) of cold food placed in either basket. Dual orifice burner has no burner tube radiants to burn out. No burner cleaning or air shutter adjustment is required. The open, stainless steel frypot has a large heat transfer area to fry more product per load. The open-pot design has no hard-to-clean tubes. Every inch of the frypot and cold zone can be cleaned and wiped down by hand.

The large cold zone catches crumbs and sediment from the frying area. These particles are trapped in the cold zone where they do not carbonize, contaminate shortening or cling to fried products.

The MJ45E model uses a 120V (220V-240V for export) supply system to accommodate additional accessories. Shortening melt cycle controls, automatic basket lifts, and the Filter Magic® System are available. Up to six MJ45E fryers can be battered with a single Filter Magic System.

The MJ45E is warranted for one year from date of original purchase against all defects in material and workmanship. Stainless-steel frypots have a lifetime warranty against defects which would cause shortening leaks.

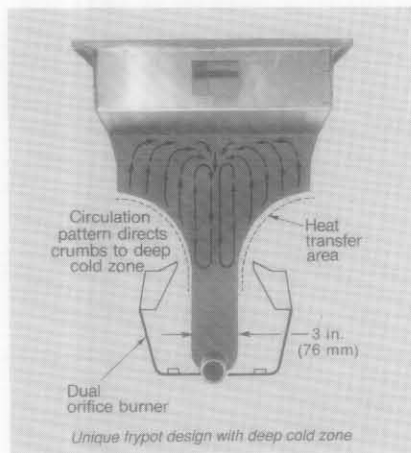

THE FRYMASTER CORPORATION

A Welbilt Company

8700 Line Avenue, P.O. Box 51000, Shreveport, Louisiana U.S.A. 71135-1000, Phone 318-865-1711

Toll free 1-800-221-4583 Fax 318-868-5987

Distributed in Canada by GARLAND COMMERCIAL RANGES, LTD., 1177 Kamato, Mississauga, Ontario L4W 1X4.

MJ45E Gas Fryers

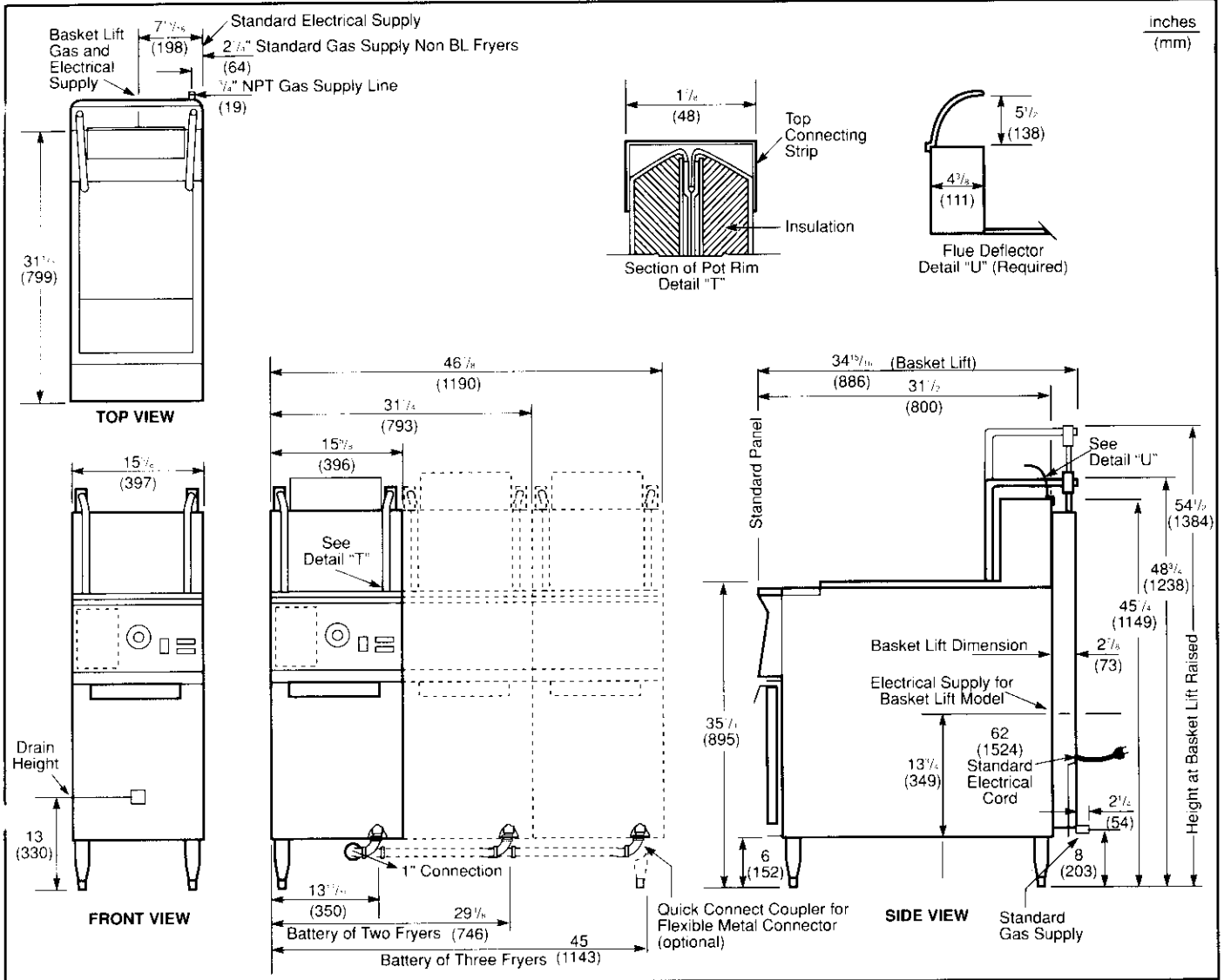

DIMENSIONS

MODEL NO.	SHORTENING CAPACITY	SIZE			NET WEIGHT	DRAIN HEIGHT	SHIPPING INFORMATION			SHIPPING DIMENSIONS		
		HEIGHT	WIDTH	LENGTH			WEIGHT	CLASS	CUBE	HEIGHT	WIDTH	LENGTH
MJ45E	40-50 lbs. (22-27 litres)	45-1/4" (1149 mm)*	15-5/8" (397 mm)*	31-1/2" (800 mm)*	200 lbs. (91 kg)	13" (330 mm)	207 lbs. (94 kg)	85	21.31	46-1/2" (1181 mm)	22" (559 mm)	36" (914 mm)

*without basket lifts

POWER REQUIREMENTS

NATURAL GAS	LP GAS	ELECTRICAL	EXPORT
122,000 BTU input 3.5" water column (36 KW, 8.7 mbar)	122,000 BTU input 8.25" water column (36 KW, 20.5 mbar)	Non-Basket Lift 120V (1.0 AMP)/220V (0.5 AMP) Basket Lift 120V (7.0 AMP)/220V (3.5 AMP)	Supply Voltage 220V 50Hz Control Voltage 24V 50Hz

NOTES

Supply Voltage 120V 60Hz - Control Voltage 24V 60Hz
 120 VAC 5 ft. (1524 mm) grounded cord set
 Single fryers require 3/4" (minimum) supply line. For 2 or more fryers, a 1-1/2" (minimum) supply line should be provided. Check plumbing codes for proper supply line sizing to attain manifold pressure of 3.5" W.C. natural or 8.25" W.C.L.P.

CLEARANCE INFORMATION

A minimum of 24" (610 mm) should be provided at the front of the unit for servicing and proper operation, and 6" (152 mm) between the sides and rear of the fryer to any combustible material.

HOW TO SPECIFY

- MJ45E** Control panel with exposed thermostat knob, signal lights, "ON/OFF" switch, 120V electric controls
- FM*45E** Up to six MJ45E fryers in battery with Filter Magic System (Filter available in any position. Please specify location).
- SD** Stainless steel pot and door - enamel cabinet
- SC** Stainless steel pot, door and cabinet

*Insert number of fryers in battery

OPTIONS AND ACCESSORIES

- Filter Magic System - Up to six fryers can be battery to Filter Magic unit
- Computer Magic III Multiproduct Frying Computer
- Automatic Basket Lifts (timer operated)
- Shortening melt cycle control
- Flexible metal connector with quick-connect coupler
- Frypot cover
- Dump station and food warmer
- Stainless steel apron drain with basket (interchangeable right or left side)
- Sediment tray
- Spreader drain
- Screen type basket support

THE FRYMASTER CORPORATION

A Welbilt Company

8700 Line Avenue, P.O. Box 51000, Shreveport, Louisiana U.S.A. 71135-1000, Phone 318-865-1711

Toll free 1-800-221-4583 Fax 318-868-5987

Distributed in Canada by GARLAND COMMERCIAL RANGES, LTD., 1177 Kamato, Mississauga, Ontario L4W 1X4.

FILTRATION

MJ45E Gas Fryers

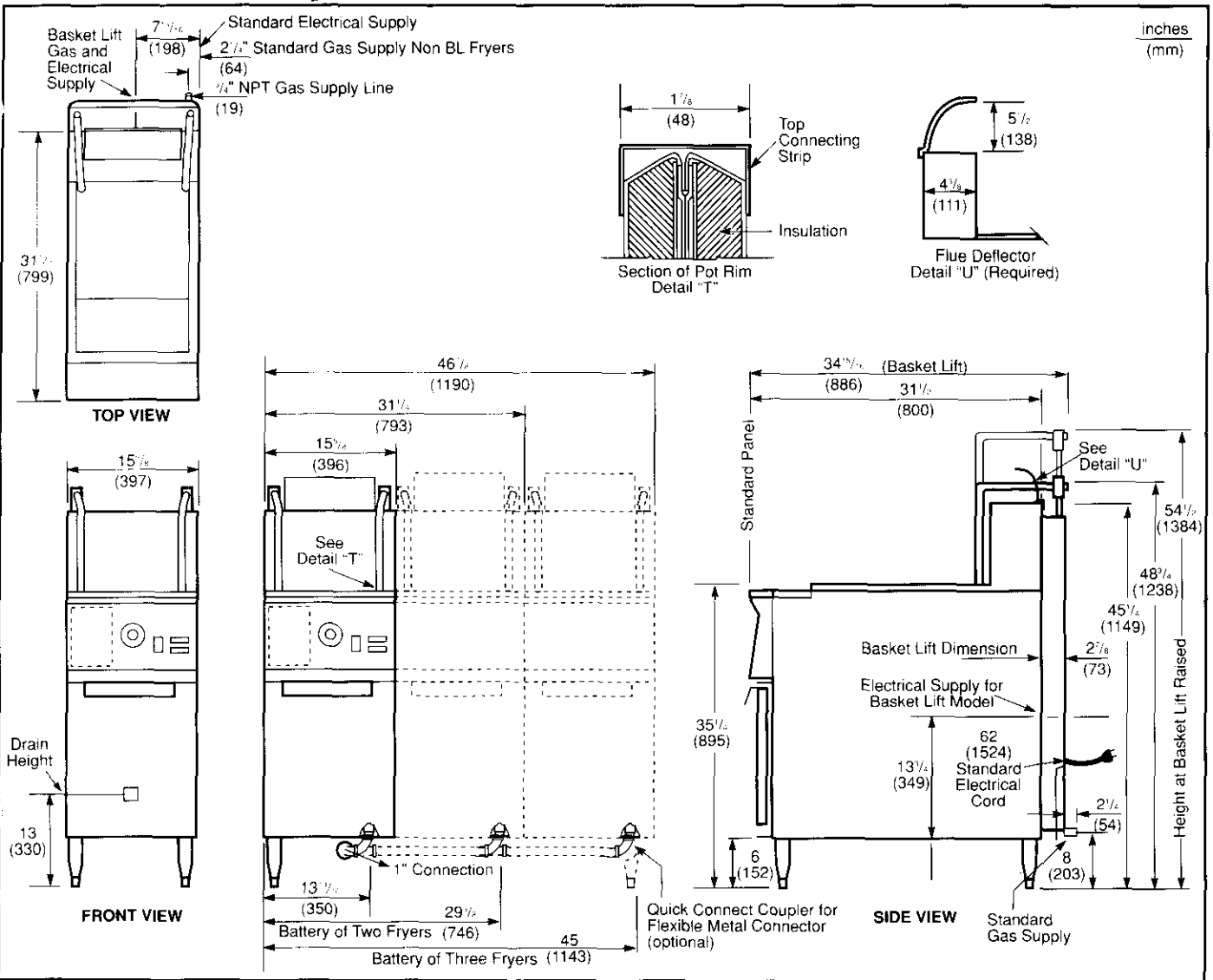

DIMENSIONS

MODEL NO.	SHORTENING CAPACITY	SIZE			NET WEIGHT	DRAIN HEIGHT	SHIPPING INFORMATION			SHIPPING DIMENSIONS		
		HEIGHT	WIDTH	LENGTH			WEIGHT	CLASS	CUBE	HEIGHT	WIDTH	LENGTH
MJ45E	40-50 lbs. (22-27 litres)	45-1/4" (1149 mm)*	15-5/8" (397 mm)*	31-1/2" (800 mm)*	200 lbs. (91 kg)	13" (330 mm)	207 lbs.	85	21.31	46-1/2" (1181 mm)	22" (559 mm)	36" (914 mm)

*without basket lifts

POWER REQUIREMENTS

NATURAL GAS	LP GAS	ELECTRICAL	EXPORT
122,000 BTU input 3.5" water column (36 KW, 8.7 mbar)	122,000 BTU input 8.25" water column (36 KW, 20.5 mbar)	Non-Basket Lift 120V (1.0 AMP)/220V (0.5 AMP) Basket Lift 120V (7.0 AMP)/220V (3.5 AMP)	Supply Voltage 220V 50Hz Control Voltage 24V 50Hz

NOTES

Supply Voltage 120V 60Hz Control Voltage 24V 60Hz
 120 VAC 5 ft. (1524 mm) grounded cord set
 Single fryers require 3/4" (minimum) supply line. For 2 or more fryers, a 1-1/2" (minimum) supply line should be provided. Check plumbing codes for proper supply line sizing to attain manifold pressure of 3.5" W.C. natural or 8.25" W.C.L.P.

CLEARANCE INFORMATION

A minimum of 24" (610 mm) should be provided at the front of the unit for servicing and proper operation, and 6" (152 mm) between the sides and rear of the fryer to any combustible material.

HOW TO SPECIFY

- MJ45E** Control panel with exposed thermostat knob, signal lights, "ON/OFF" switch, 120V electric controls
- FM*45E** Up to six MJ45E fryers in battery with Filter Magic System (Filter available in any position. Please specify location).
- SD** Stainless steel pot and door - enamel cabinet
- SC** Stainless steel pot, door and cabinet

*insert number of fryers in battery

OPTIONS AND ACCESSORIES

- Filter Magic™ System - Up to six fryers can be battered to Filter Magic unit
- Computer Magic™ III Multiproduct Frying Computer
- Automatic Basket Lifts (timer operated)
- Shortening melt cycle control
- Flexible metal connector with quick-connect coupler
- Frypot cover
- Dump station and food warmer
- Stainless steel apron drain with basket (interchangeable right or left side)
- Sediment tray
- Spreader drain
- Screen type basket support

THE FRYMASTER CORPORATION

A Welbilt Company

8700 Line Avenue, P.O. Box 51000, Shreveport, Louisiana U.S.A. 71135-1000, Phone 318-865-1711

Toll free 1-800-221-4583 Fax 318-868-5987

Distributed in Canada by GARLAND COMMERCIAL RANGES, LTD., 1177 Kamato, Mississauga, Ontario L4W 1X4.

OPERATING INSTRUCTIONS

CAUTION:

EXTREME CARE MUST BE EXERCISED WHEN WORKING WITH HOT SHORTENING.

PREPARING THE FILTER UNIT FOR USE

1. Remove the filter unit from the cabinet.
2. Remove the crumb tray and the paper hold-down ring.

NOTE: Be sure the inside of the pan is free of all food and breading particles that could prevent the paper from sealing against the bottom of the pan and clogging the Power Shower with crumbs.

3. Position the support screen in the pan with the 90° lip down.
4. Position the filter paper on top of the support screen with the edges lapping up the sides and ends of pan.

NOTE: The Frymaster filter paper is larger than the inside dimensions of the filter pan. This creates a better seal when the hold-down ring is placed into the pan on top of the paper. DO NOT use filter paper that is shorter or more narrow than the filter paper support screen. This will result in the filter pump becoming clogged with sediment.

5. Insert the paper hold-down ring and push down against overlapping edges of paper until ring is against bottom of pan. Add powder per instructions on package and insert the crumb tray in the filter pan.
6. Roll the filter pan back into the fryer cabinet, making sure that it is positioned all the way to the back of the cabinet. When the filter pan is properly positioned, the green, system-ready light located on the filter control panel will come on.

OPERATION OF THE FILTER UNIT

CAUTION:

NEVER OPERATE THE FILTER UNIT UNLESS THE FRYERS HAVE BEEN BROUGHT UP TO COOKING TEMPERATURE.

1. To filter the fryer, turn the fryer power OFF, open the drain valve on the fryer you have selected to be filtered, and use the Fryer's Friend steel rod to free the drain from inside the frypot as necessary.

NOTE: Exercise care when using the Fryer's Friend to prevent damage to the frypot and drain valve.

CAUTION: DO NOT DRAIN MORE THAN ONE FRYER AT A TIME. TO DO SO, WILL CAUSE OVERFILLING OF THE FILTER PAN.

2. Snap Power Shower into the frypot connection.

NOTE: Power Shower is an optional item.

3. Engage the filter lever to start pump. Hot shortening will jet over the inside surface of the frypot flushing crumbs and sediment into the filtering system.

NOTE: On fryers with the rear-flush option, the control lever is located on the square drain. You can select Power Shower or cold zone flush. The cold zone flush will wash sediment from the bottom of the frypot.

NOTE: Filter pump is equipped with a manual reset switch in case the filter motor overheats or an electrical fault occurs.

WARNING

Turn off power to filter system and allow pump motor to cool 20 minutes before attempting to reset switch on pump motor.

4. After shortening is completely filtered, close the drain valve and allow the fryer to fill before disengaging the filter lever to turn off the filter pump.

NOTE: When using solid shortening, allow the filtering system to run five (5) to ten (10) seconds after bubbles appear in order to clear the lines and in order to prevent solid shortening from hardening in the line and clogging the filter.

5. Remove the Power Shower assembly.
6. Turn the fryer ON to start the cooking operation.

WARNING

The filter pan MUST NEVER be used to dispose of nor to transport used shortening to the shortening disposal area. Shortening MUST ALWAYS be allowed to cool below 100°F (38°C) before transporting to the disposal area. A Frymaster Shortening Disposal Unit (SDU) is available and highly recommended for safety. When other means of storing or transporting shortening is needed, a metal container with a sealable, securely fastened cover is required.

CHANGING THE FILTER PAPER

NOTE: Allow filter pan to cool completely before attempting to change the paper.

1. Remove the filter pan from the fryer cabinet.
2. Remove and clean the crumb tray.

3. Remove the hold-down ring from the filter pan.
4. Remove and discard the used (old) filter paper.
5. Remove filter paper screen and clean.
6. Clean all breadings and food particles from the filter pan.

NOTE: Inner pan may be removed from the outer pan assembly for cleaning.

7. Refer to the section Preparing the Filter Unit For Use for the next operation.

CARE AND CLEANING OF FRYER FILTERING SYSTEM

CAUTION:

NEVER OPERATE THE FRYER OR FILTERING SYSTEM WITHOUT SHORTENING IN THE SYSTEM.

The shortening should be filtered as often as needed. If a heavy volume of breaded food is fried, it may be necessary to filter as often as every hour. This will increase the life of the shortening and produce a better-tasting product. The best rule to follow is to filter before you think it is needed. Even with a product such as french fries, you should filter two (2) to three (3) times per day for best results.

Also, the frypot should be cleaned periodically. This operation, combined with the disposing of the used shortening, enhances the flavor of the food product. After the fryer has been emptied, the frypot should be drained and the drain valve closed. Fill the frypot to the oil-level line with water and the correct amount of Frymaster Fryer N' Griddle Cleaner, then put the baskets into the frypot and bring the solution to a simmer condition for one (1) hour. Then turn OFF the fryer, drain the solution, and wipe the frypot clean and dry.

NOTE: Do not drain water into the filter pan. Water will damage the filter pump, necessitating replacement. Use a stock pot or bucket. The inner and outer filter pan must be cleaned on initial startup and periodically thereafter.

1. To clean the inner filter pan, remove from outer pan and take to a sink filled with warm water and grease-cutting detergent.
2. Scrub the inner pan with a nylon pot brush.
3. When clean, rinse thoroughly to remove all detergent and wipe dry with a clean, dry cloth or paper towels.

4. To clean the outer filter pan, pour one (1) quart (one (1) liter) of warm water mixed with grease-cutting detergent into the pan. Scrub the pan thoroughly inside ONLY with the pot brush until clean.
5. Pour the solution from the outer pan into kitchen drain or sink.
6. Rinse with clean water and drain into kitchen drain or sink.
7. Turn the pan upside down and slightly elevate on sink drain board to allow all water to drain from suction tube.

CAUTION:

All water must be removed from the suction tube before inserting inner pan.

8. After suction tube is free of water, wipe inside and outside with a clean, dry cloth or paper towels.
9. Insert inner pan back into outer pan and refer to Step 3 of PREPARING THE FILTER UNIT FOR USE.

POWER SHOWER CARE AND CLEANING

The stainless steel Power Shower assembly practically cleans itself as the hot shortening is forced through the tubing during the filtration process. However, the operator must be sure to drain the Power Shower thoroughly once it is removed from the fryer, after the filtering operation is completed.

To check for any stoppage in the tubing:

1. Remove the plugs at each corner of the Power Shower frame.
2. Insert a long, narrow bottle brush into the tube to dislodge any particles. Hot water and grease-cutting detergent may be used in conjunction with the bottle brush to clean inside the Power Shower tube.

NOTE: When hot water and detergent are used to clean the Power Shower, the Power Shower must be rinsed, thoroughly dried, and plugs reinserted before reusing.

FILTER SYSTEM TROUBLESHOOTING GUIDE

PROBLEM	PROBABLE CAUSE	CORRECTIVE ACTION
Filter heat light does not glow.	<ul style="list-style-type: none"> A. Filter pan not in position. B. Loose wire. C. Defective light. D. Defective heater. E. Contactor broken or misaligned. F. Defective transformer. 	<ul style="list-style-type: none"> A. Position pan properly. B. Replace wire. C. Replace light. D. Replace heater. E. Replace or realign. F. Replace transformer.
Filter heater will not heat.	<ul style="list-style-type: none"> A. Pan not in position. B. Contactor broken or misaligned. C. Heater defective. D. Defective transformer. 	<ul style="list-style-type: none"> A. Position pan properly. B. Replace or realign. C. Replace heater. D. Replace transformer.
Pump will not pump.	<ul style="list-style-type: none"> A. Pan not in position. B. Broken o-ring on fitting. C. Shortening solidified in pan. D. Pump microswitch broken or not adjusted. E. Pump relay defective. F. Thermo overload tripped. 	<ul style="list-style-type: none"> A. Position pan properly. B. Replace o-ring. C. Allow heater to melt shortening. D. Replace or realign. E. Replace relay. F. Reset.
Fryer trouble light ON or computer shows "HELP".	<ul style="list-style-type: none"> A. Drain switch not closed. B. Loose wire. C. Defective drain valve microswitch. D. Microswitch out of adjustment. 	<ul style="list-style-type: none"> A. Close drain valve. B. Replace wire. C. Replace switch. D. Adjust switch.
Drain tube leaking.	<ul style="list-style-type: none"> A. Defective gasket. B. Loose connection. 	<ul style="list-style-type: none"> A. Replace gasket. B. Tighten connection.
Filter Power Shower not spraying properly.	<ul style="list-style-type: none"> A. Stoppage in tubing. B. Filter pan connection not properly engaged. C. Shower assembly not properly installed. D. O-ring lost or defective. 	<ul style="list-style-type: none"> A. Disassemble Power Shower and clean. B. Position pan properly. C. Install properly. D. Replace o-ring.

**PLAN WIRING DIAGRAM
FOR FILTER MAGIC II**

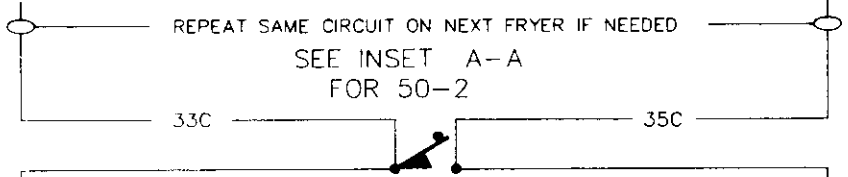

1 ST. FRYER - RIGHT OF FILTER

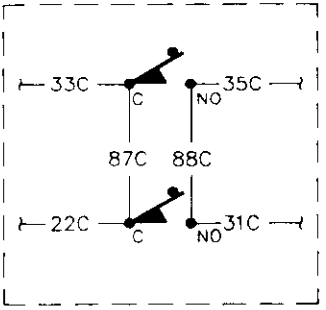

INSET A-A

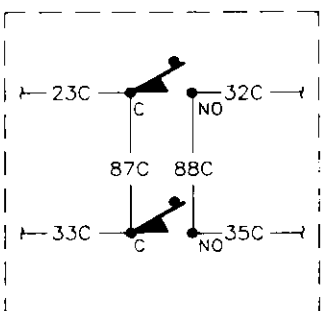

INSET B-B

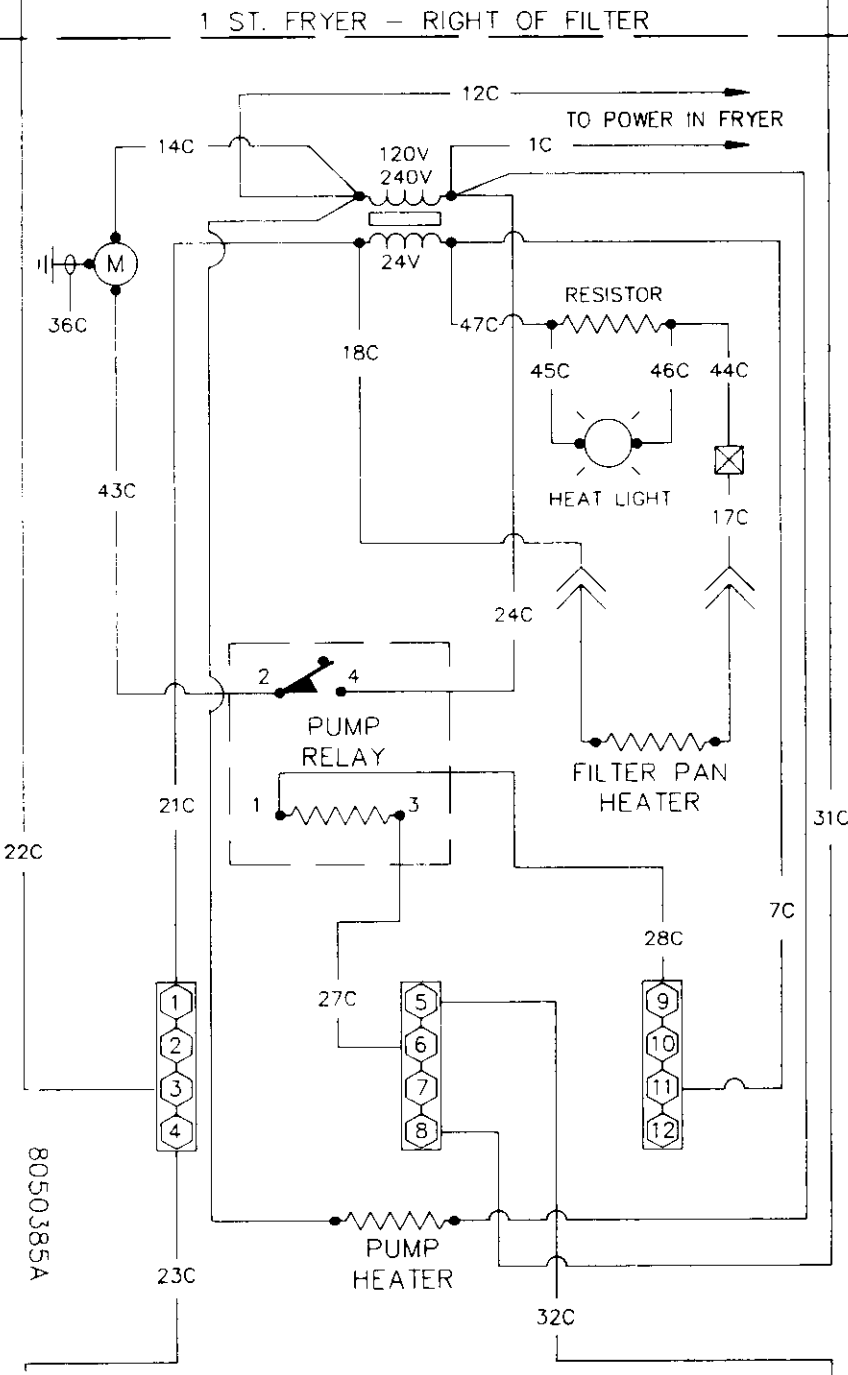

(DIRECT)

PLAN WIRING DIAGRAM FOR FILTER MAGIC II

1 ST. FRYER - LEFT OF FILTER

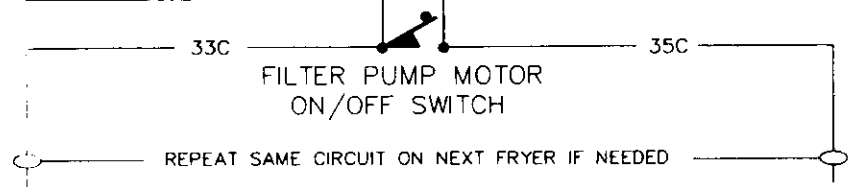

SEE INSET B-B
FOR 50-2

BASKET LIFT

INSTALLATION INSTRUCTIONS

For convenience in shipping your fryer, the basket hanger assemblies are shipped in the "down" position. Before starting your fryer, install the basket rest arms. For fryers equipped with computers or basket lift timer controllers, basket lift rods will come up automatically when unit is plugged into electrical outlet.

on the computer or basket lift timer controller. The basket(s) will be lowered into the shortening. At the completion of the timed cycle, the baskets will automatically be raised. To repeat the cycle, simply depress the desired product button to lower the baskets.

OPERATING INSTRUCTIONS

Fryers Equipped With Computers or Basket Lift Timer Controllers:

After fryer has reached the programmed cooking temperature, press the desired product button(s)

To change the time cycle on fryers equipped with Computer or Basket Lift Timer Controller:

Refer to Computer Programming Section page 11 or Electronic Timer Controller Section page 14 of this manual.

BASKET LIFT TROUBLESHOOTING

PROBLEM	PROBABLE CAUSE	CORRECTIVE ACTION
Lifts Continuously Travel Up and Down.	<ul style="list-style-type: none"> A. Microswitch out of adjustment. B. Microswitch broken. C. Defective basket lift relay on interface board. 	<ul style="list-style-type: none"> A. Adjust microswitch to allow proper contact with bell crank. B. Replace broken microswitch. C. Replace basket relay.
Basket Lift Timer or Computer Will Not Activate Gearmotor.	<ul style="list-style-type: none"> A. Loose or broken wire between interface board and gearmotor. B. Loose or broken wire connections at basket lift timer or computer. C. Wire loose in disconnect plug at rear of interface board. D. Defective basket lift timer or computer. E. Trace on interface board burned open. F. Defective timer or computer 	<ul style="list-style-type: none"> A. Repair or replace wire as necessary. B. Repair or replace wire connections as necessary. C. Push wires into disconnect to allow proper contact. D. Replace timer or computer. E. Replace interface board. F. Replace timer or computer.
Power To Gearmotor But Gearmotor Does Not Move.	<ul style="list-style-type: none"> A. Defective gearmotor. B. Basket lift rod jammed in rod bushings. 	<ul style="list-style-type: none"> A. Replace gearmotor. B. Remove basket lift enclosure and clean rods and bushings.
Lift Arm Does Not Stop In The Raised Position — Lowers Back Into Pot and Stops.	<ul style="list-style-type: none"> A. Defective gears or brake in gear motor. 	<ul style="list-style-type: none"> A. Replace gearmotor.
Basket Lift Rods Binding	<ul style="list-style-type: none"> A. Rod bushings need lubrication. 	<ul style="list-style-type: none"> A. Grease basket lift rods and bushing with Lubriplate type grease.