

BIPH52/55-MPH52/55 GAS FRYERS

CHAPTER 2: PARTS LIST

2.1 Accessories

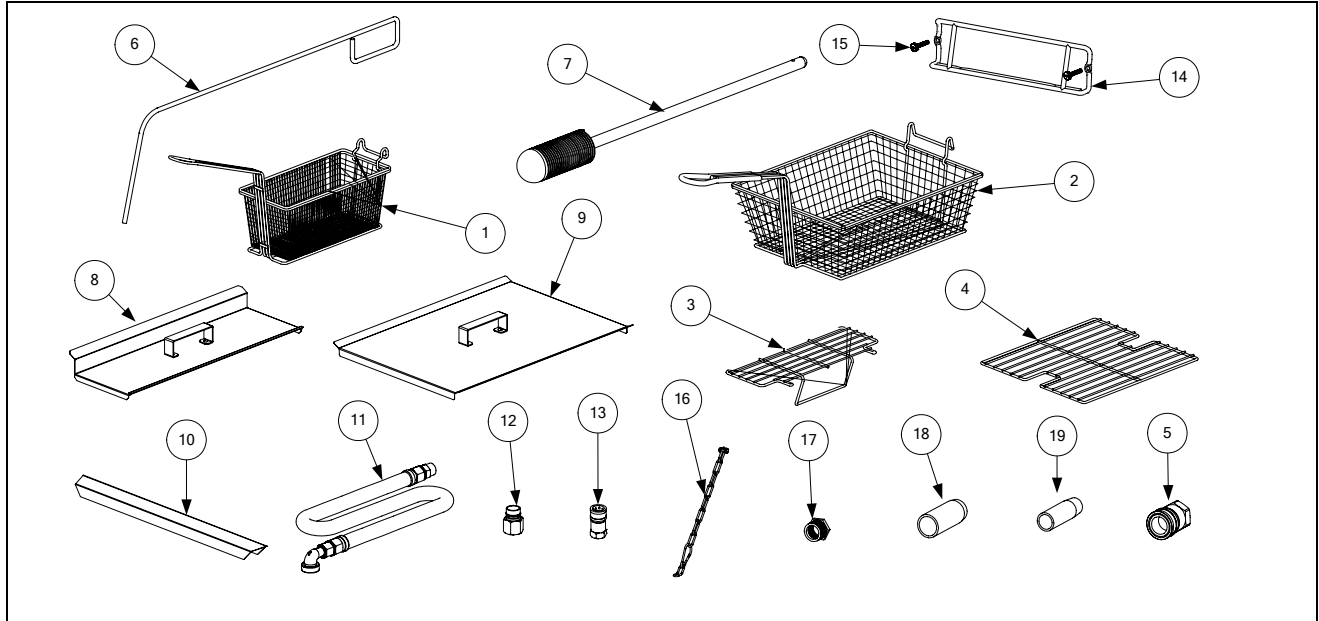

ITEM	PART #	COMPONENT
1	803-0271	Basket, Twin
2	803-0099	Basket, Full (cannot be used with basket lifts)
3	803-0133	Basket Support Rack, Dual Vat
4	803-0132	Basket Support Rack, Full Vat
*	803-0136	Basket Support Screen, Full Vat (screen w/handle used in place of Item 4)
5		Coupling, Gas Line Female Quick Disconnect
	810-0070	3/4-inch
	810-0073	1-inch
6	803-0197	Cleanout Rod, 27-inch (Fryer's Friend)
7	803-0209	Brush, Frypot
8	806-3407	Cover, Frypot, Dual Vat
9	806-3068	Cover, Frypot, Full Vat
*	826-0993SP	Handle Kit, Frypot Cover (includes handle and screws)
10	910-7443	Connecting Strip, Frypot
11	810-0478	Gas Line, 1-Inch Dormont Flexible
	806-1698SP	36-Inch (for gas line only (w/o Items 12 and 13), use 810-0088)
	806-1699	48-Inch (for gas line only (w/o Items 12 and 13), use 810-0085)
12	810-0074	Quick-Disconnect Fitting, 1-Inch Male
13	810-0073	Quick-Disconnect Fitting, 1-Inch Female
14	810-2793	Hanger, Basket
15	809-0171	Thumbscrew, 1/4-20 X 1 3/8-inch Basket Hanger
*	809-0921	Spacer, Basket Hanger
16	826-0900	Kit, Chain Restraint
17	826-1045	Bushing, Flexible Gas Line (813-0032)

ITEM	PART #	COMPONENT
18	812-1378	Drain Extension, Non-Filter Full Vat Fryer
19	812-1374	Drain Extension, Non-Filter Dual Vat Fryer
*	803-0219	Pad, McDonald's FPIII Universal Filter
*	803-0170	Filter Pack, Paper – 100 Sheets
*	803-0002	Powder, Filter – 80 Packages
*	826-1157	Kit, Fuse and Fuse Puller (2 Fuses)

* Not illustrated.

2.2 Cabinetry

2.2.1 Backs, Doors, Flue Caps, Sides, Top Caps, Standoffs and Cap-N-Splash Assemblies

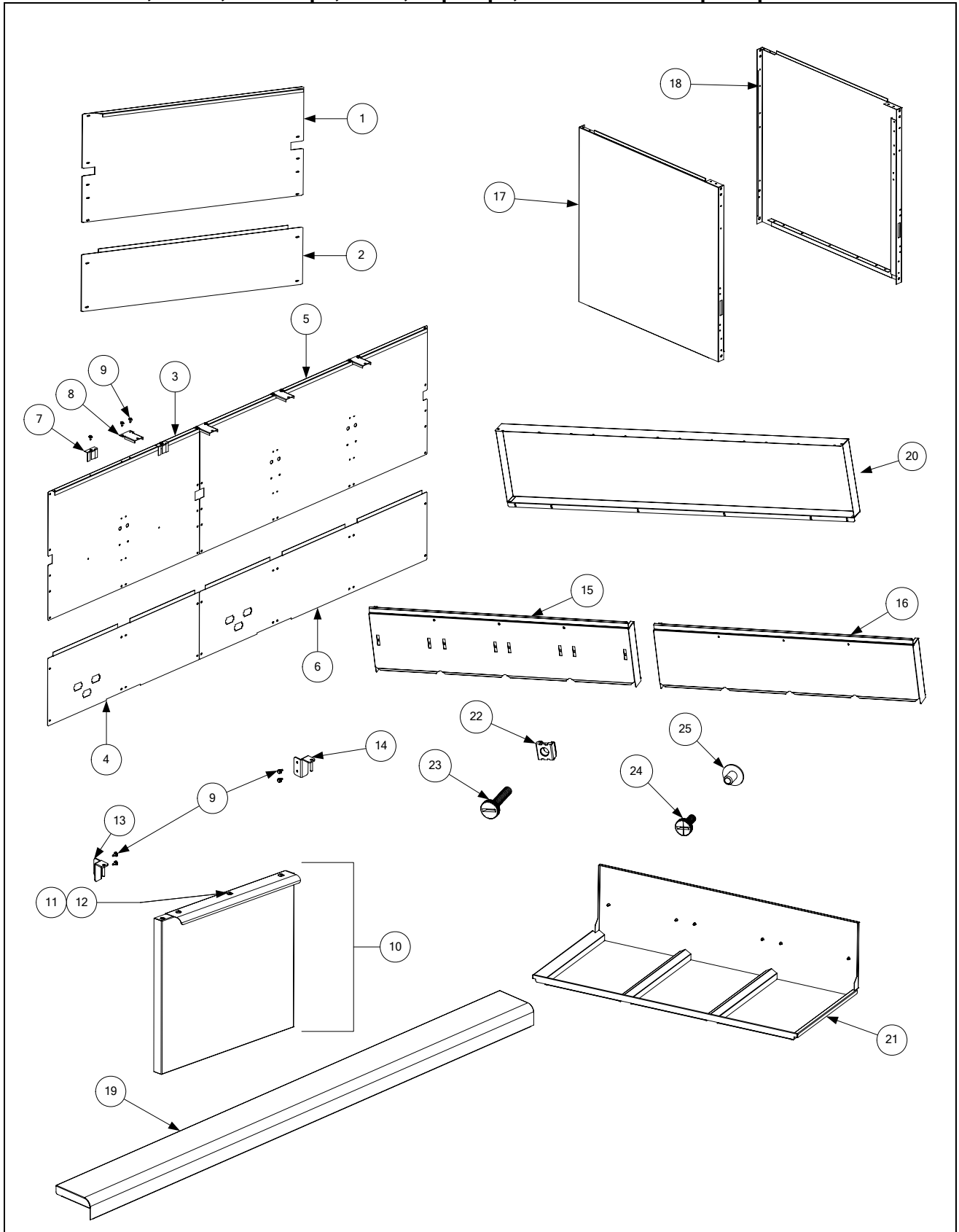

ITEM	PART #	COMPONENT
1		Back, Single Upper
	210-6581	Stainless Steel
	200-6581	Cold Rolled Steel
2		Back, Single Lower
	210-6580	Stainless Steel
	200-6580	Cold Rolled Steel
3		Back, Double Upper (for 2-, 4-, and 5-station fryers – does not include Items 7-9)
	210-6542	Stainless Steel
	200-6540	Cold Rolled Steel
4		Back, Double Lower (for 2-, 4-, and 5-station fryers – does not include Items 7-9)
	210-6541	Stainless Steel
	200-6539	Cold Rolled Steel
5		Back, Triple Upper (for 3- and 5-station fryers – does not include Items 7-9)
	210-6545	Stainless Steel
	200-6547	Cold Rolled Steel
6		Back, Triple Lower (for 3- and 5-station fryers – does not include Items 7-9)
	210-6544	Stainless Steel
	200-6546	Cold Rolled Steel
7	200-6419	Clip, Flue Support
8	200-5865	Support, Flue Cap
9	826-1374	Screw, #10 X ½-inch Hex Washer Head (Pkg. of 25)
10	106-3966	Door, Left or Right (Left shown – move handle to bottom for Right)
11	809-0266	Screw, #10 X ½-inch Phillips Truss Head
12	210-6816	Handle, Door
13	823-4729	Hinge, Left Door Upper
14	823-4730	Hinge, Right Door Upper
15		Flue Cap-Stainless Steel (Does not include Item 27)
	210-5549	Single Fryer
	106-3579	2-Station Fryer
	106-3537	3-Station Fryer
	106-3535	4-Station Fryer
	106-3536	5-Station Fryer
16		Flue Cap - Aluminized Steel for use with Cap-N-Splash
	210-5525	Single Fryer
	106-3539	2-Station Fryer
	106-3540	3-Station Fryer
	106-3542	4-Station Fryer
	106-3543	5-Station Fryer
17		Side, Left Standard Cabinet
	211-6510SP	Stainless Steel
	201-6633	Enameled Steel
18		Side, Right Standard Cabinet
	212-6510SP	Stainless Steel
	202-6633	Enameled Steel
19		Top Cap (Cap for 5-staion fryer shown)
	824-1310	Single Fryer <i>(use 824-1689 for fryers mfd. After 3.15.06)</i>
	824-1357	2-Station Fryer <i>(use 824-1690 for fryers mfd. After 3.15.06)</i>
	823-4702	3-Station Fryer <i>(use 823-5733 for fryers mfd. After 3.15.06)</i>
	823-4704	4-Station Fryer <i>(use 824-5734 for fryers mfd. After 3.15.06)</i>
	823-4706	5-Station Fryer <i>(use 824-5735 for fryers mfd. After 3.15.06)</i>

ITEM	PART #	COMPONENT
20		Standoffs
	200-6582	Single Fryer
	200-6553	2-Station Fryer
	200-6554	3-Station Fryer
	200-6555	4-Station Fryer
	200-6556	5-Station Fryer
21		Cap-N-Splash Assemblies
	823-3066	Single Fryer
	823-3067	2-Station Fryer
	823-3068	3-Station Fryer
	823-3070	4-Station Fryer
	823-3069	5-Station Fryer
22	826-1351	Nut Retainer, ¼-20 (Pkg. of 10 – for basket hanger thumbscrew) for Std. Fluecap
23	809-0171	Thumbscrew, ¼-20 x 1¾-inch (for use on Standard Fluecap)
24	809-0402	Thumbscrew, ¼-20 x ½-inch (for use on Cap-N-Splash Assembly)
25	809-0535	T-Nut, ¼-20 x 7/16-inch (for use on Cap-N-Splash Assembly)

2.2.2 Filter Cabinet Bases, Casters, Framing, and Related Components

The 5-station cabinet illustrated is typical of all BIPH52/55 Series Gas filter cabinets. All base and framing components used in BIPH52/55 Gas filter cabinets are identified, but not all components are used in every configuration.

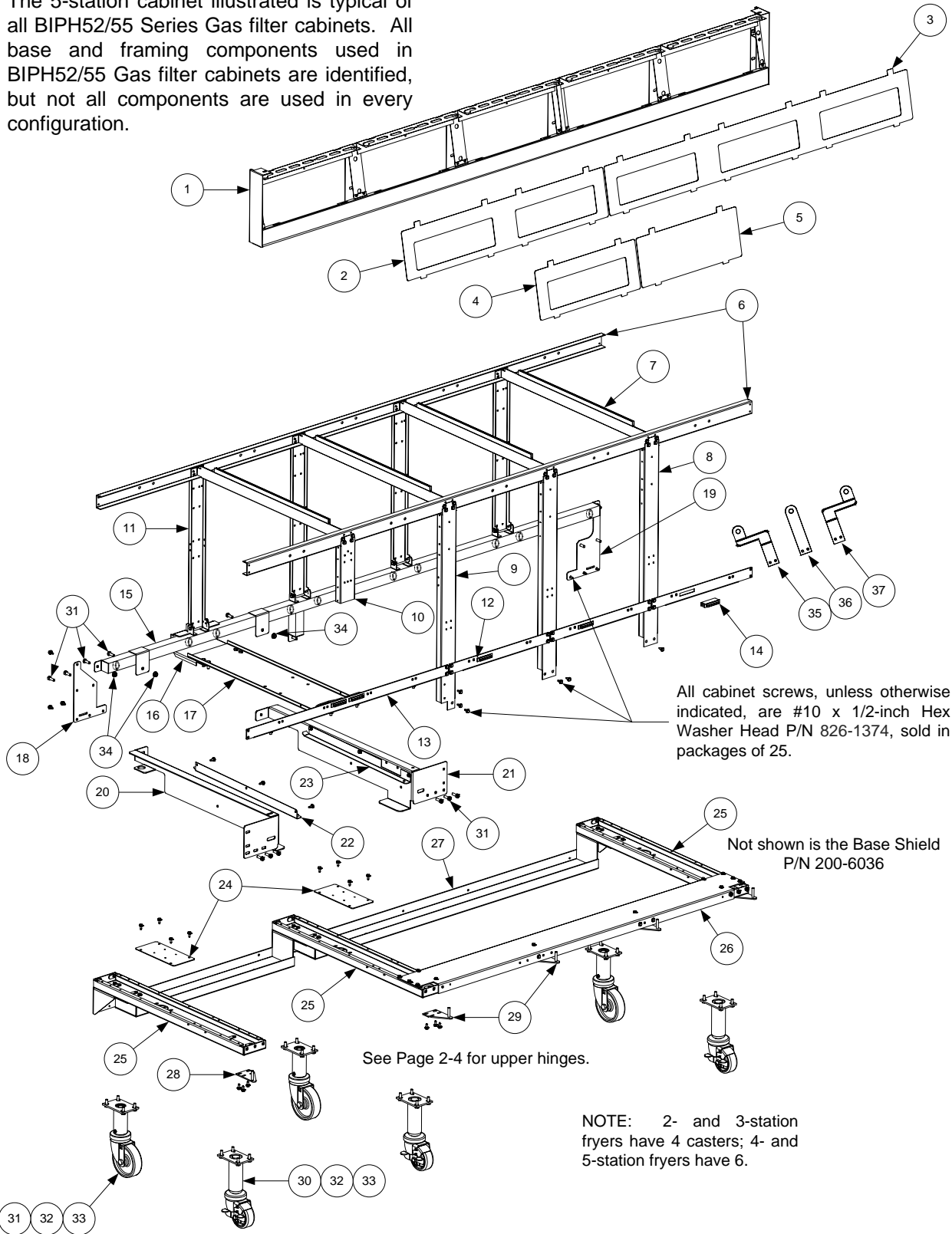

ITEM	PART #	COMPONENT
1	106-4303	Frame, Control Panel, Two Station, (<i>use 106-5221SP mfd. After 3.15.06</i>)
	106-4304	Three-Station, Standard (<i>use 106-5018SP mfd. After 3.15.06</i>)
	106-4305	Four-Station, Standard (<i>use 106-5019 mfd. After 3.15.06</i>)
	106-4306	Five-Station, Standard (<i>use 106-5020 mfd. After 3.15.06</i>)
2	210-5819	Bezel, Two-Controller
3	210-6698	Bezel, Three-Controller
4	210-5046	Bezel, One-Controller
5	210-5623	Bezel, Blank
6	900-7730	Brace, Cabinet Top Two-Station
	900-9430	Three-Station
	900-9318	Four-Station
	200-5474	Five-Station
7	200-5478	Divider, Cabinet
8	200-9217	Post, Cabinet Front
9	200-6031	Post, Filter Door
10	200-2235	Bracket, Component Box Support
11	200-6550	Post, Cabinet Rear
12	200-1953	Brace, Front Cabinet
13	200-6507	Support, Cross Cabinet
14	810-1105	Magnet, Door
15		Manifold, Rear (for units w/ filtration also see page 2-17 for additional parts)
	810-2890	Two-Station
	810-2891	Three-Station
	810-2892	Four-Station
	810-2893	Five-Station
16	200-2213	Bracket, Rear Bridge Support
17	200-9818	Bridge, Filter Pump
18	200-6326	Gusset, Left Rear Corner
19	200-7031	Gusset, Right Rear Corner
20	201-9467	Support, Left Filter Rail
21	202-9467	Support, Right Filter Rail
22	823-4651	Slide, Filter Pan Lid Left
23	823-4652	Slide, Filter Pan Lid Right
24	200-2102	Brace, Side Channel
25	823-4653	Channel, Side Base
26		Channel, Front Base (not used in two-station fryers)
	200-6609	Three-Station
	200-6610	Four-Station
	200-5473	Five-Station
27	823-4510	Channel, Rear Base Two-Station
	823-4630	Three-Station
	823-4629	Four-Station
	823-4628	Five-Station
28	823-4732	Hinge, Lower Left
29	823-4733	Hinge, Lower Right (<i>attach to Hinge Bracket 200-5478 in 4- & 5-station fryers</i>)
30	810-0944	Caster w/Brake, 8½ to 10-inch Adjustable (3-inch wheel)
31	810-0327	Caster w/o Brake, 8½ to 10-inch Adjustable (4-inch wheel)
32	809-0953	Bolt, ¼-20 x ¾-inch Hex Head
33	809-0191	Washer, ¼-inch Lock
34	809-0417	Nut, ¼-20 Flange
35	201-6720	Mount, Rear Flush Rod Offset, Left
36	200-6697	Mount, Rear Flush Rod Holder, Center
37	202-6720	Mount, Rear Flush Rod Offset, Right
*	200-6036	Base Shield

2.2.3 Non-Filter Cabinet Bases, Casters, Framing, and Related Components

The 5-station cabinet illustrated is typical of all MPH52/55 Series Gas non-filter cabinets. All base and framing components used in MPH52/55 Series Gas non-filter cabinets are identified, but not all components are used in every configuration.

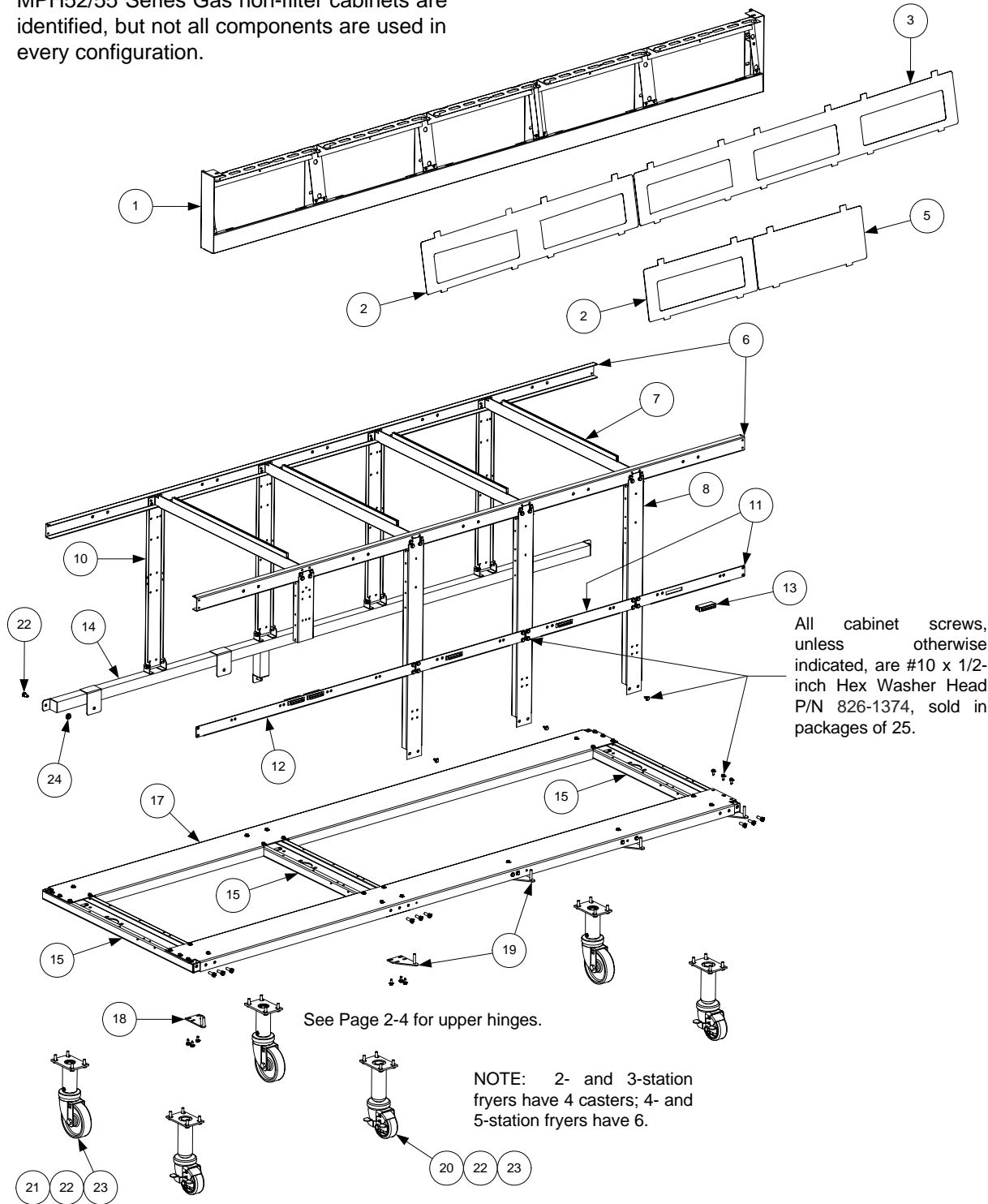

ITEM	PART #	COMPONENT
1		Frame, Control Panel
	106-4302	Single-Station, Standard (<i>use 106-5016 mfd. After 3.15.06</i>)
	106-4303	Two-Station, Standard (<i>use 106-5221SP mfd. After 3.15.06</i>)
	106-4304	Three-Station, Standard (<i>use 106-55018SP mfd. After 3.15.06</i>)
	106-4305	Four-Station, Standard (<i>use 106-5019 mfd. After 3.15.06</i>)
	106-4306	Five-Station, Standard (<i>use 106-5020 mfd. After 3.15.06</i>)
2	210-5819	Bezel, Two-Controller
3	210-6698	Bezel, Three-Controller
4	210-5046	Bezel, One-Controller
5	210-5623	Bezel, Blank
6		Brace, Cabinet Top
	200-5498	Single Fryer
	900-7730	Two-Station
	900-9430	Three-Station
	900-9318	Four-Station
	200-5474	Five-Station
7	200-5478	Divider, Cabinet
8	200-6614	Post, Cabinet Front
9	200-2235	Bracket, Component Box Support
10	200-6550	Post, Cabinet Rear
11	200-1953	Brace, Front Cabinet
12	200-6507	Support, Cross Cabinet
13	810-1105	Magnet, Door
14		Manifold, Rear (not present in single fryers)
	823-3223	Two-Station
	823-4691	Three-Station
	823-4693	Four-Station
	823-4694	Five-Station
15	823-4653	Channel, Side Base
16		Channel, Front Base
	200-6616	Single Fryer (<i>also used as rear base channel in single-station fryers</i>)
	200-6623	Two-Station (<i>also used as rear base channel in single-station fryers</i>)
	200-6624	Three-Station (<i>also used as rear base channel in single-station fryers</i>)
	200-6625	Four-Station
	200-6627	Five-Station
17		Channel, Rear Base
	200-6626	Four-Station
	200-6628	Five-Station
18	823-4732	Hinge, Lower Left
19	823-4733	Hinge, Lower Right (<i>attach to Bracket 200-5478 in 3-, 4-, & 5-station fryers</i>)
20	810-0944	Caster w/Brake, 8½ to 10-inch Adjustable (3-inch wheel)
21	810-0327	Caster w/o Brake, 8½ to 10-inch Adjustable (4-inch wheel)
22	809-0953	Bolt, ¼-20 x ¾-inch Hex Head
23	809-0191	Washer, ¼-inch Lock
24	809-0417	Nut, ¼-20 Flange

2.3 Controllers and Associated Components

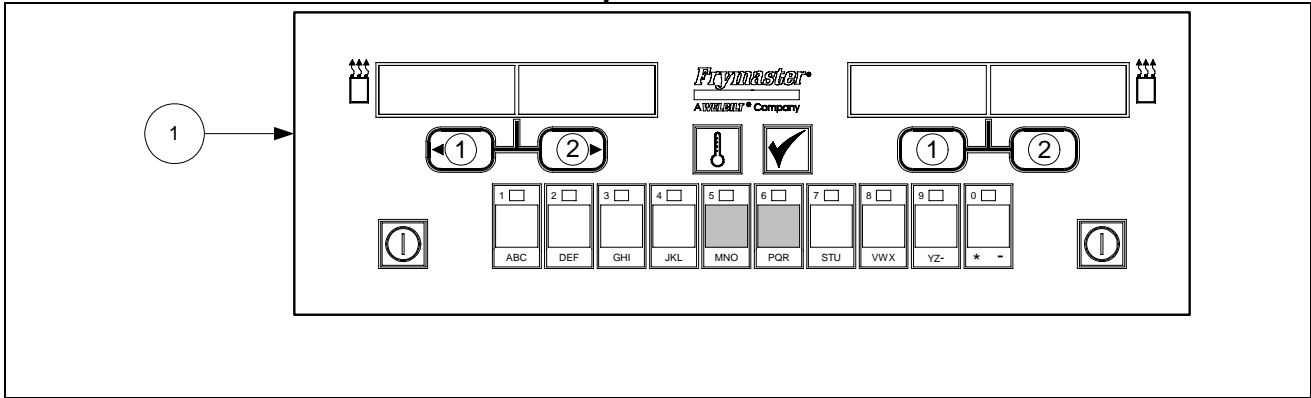

ITEM	PART #	COMPONENT
1		Computer, McDonald's M2000 Gas Fryer
	106-1269	Full Vat (Domestic U.S.) Can also be programmed for Dual Vat.
	106-0672	Full Vat (CE) Can also be programmed for Dual Vat.
	106-5950	Full Vat (CE) Can also be programmed for Dual Vat (<i>Australia Only</i>)
*	807-3520	M2000 Speaker

* Not illustrated.

2.4 Drain, Filtration, and Oil Return System Components

2.4.1 Filtration System Components

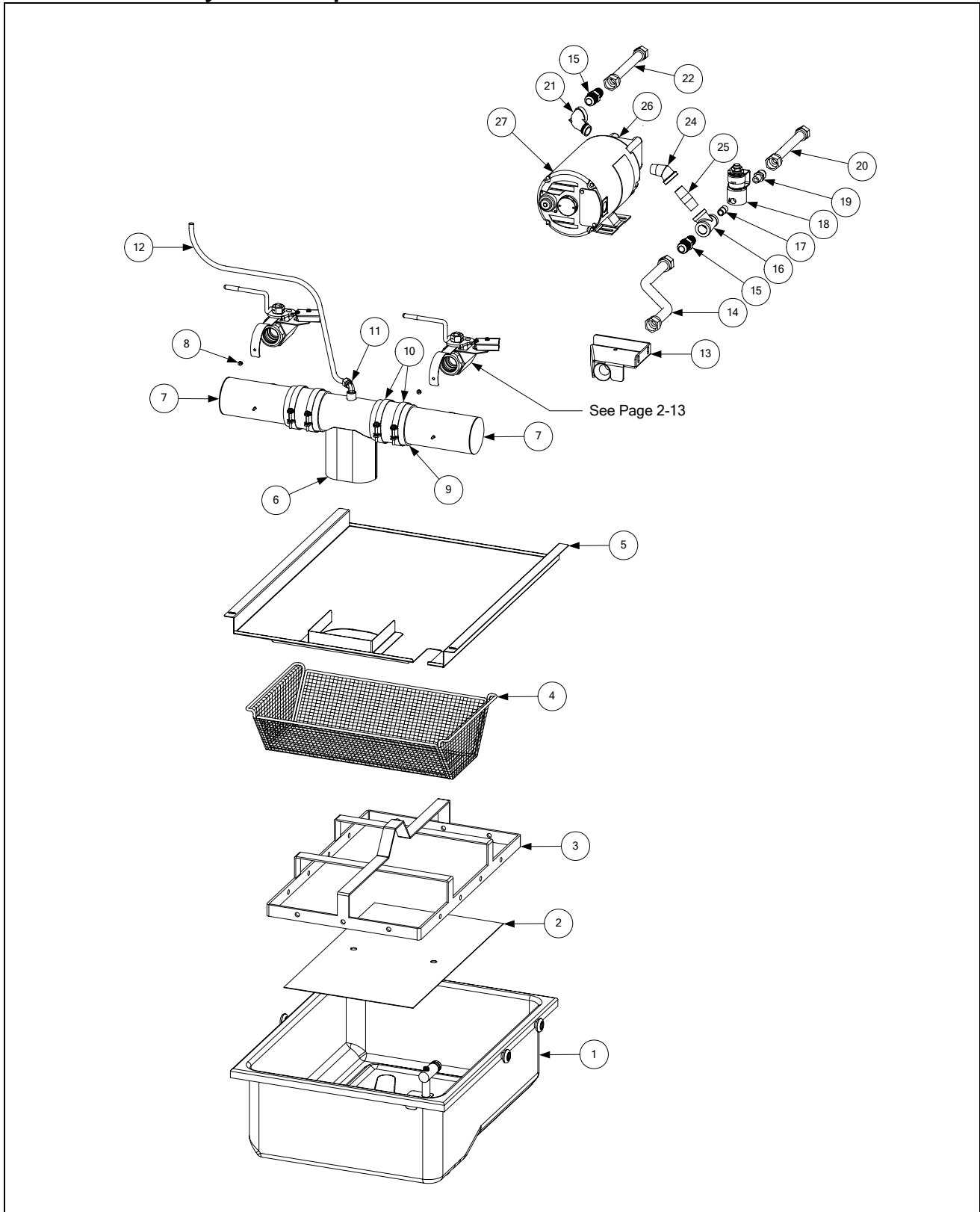

ITEM	PART #	COMPONENT
1	106-2617SP 826-1980 823-3930SP 813-0568 826-1392 810-2198 826-1372 826-1979	Pan Assembly, FootPrint Pro Filter (incl. O-rings, rollers, nuts & crumb tray) Pan Assembly – No Screen Pan Assembly, Filter Plug, 1/8-inch NPT Socket Head O-Ring (two required) (Pkg. of 5) Roller, Filter Pan Nut, 1/4-20 Hex Flange (Pkg. of 10) Kit- Contains four each of roller 810-2198 and 1/4-20 Flange Nut 809-0059
2	200-2240	Screen, Sana Grid
3	810-2183 810-2091	Ring, Filter Pad Hold-Down Ring (11.20-inch X 19.10-inch) Ring, Filter Paper Hold-Down Ring (13.47-inch X 21.41-inch)
4	823-5146	Tray, Filter Pan Crumb
5	823-5249	Lid, Filter Pan
6	823-4678 823-4708	Tube, 3-inch Center Drain (Open Both Ends) Closed One End
7		Tube, 3-inch Round Drain (823-4625 illustrated)
	823-4638 823-4640 823-4624 823-4642 823-4639 823-4641 823-4625 823-4643 200-6473 200-6474	Dual Vat, Long (one end closed) Dual Vat, Long (open both ends) Dual Vat, Short (one end closed) Dual Vat, Short (open both ends) Full Vat, Long (one end closed) Full Vat, Long (open both ends) Full Vat, Short (one end closed) Full Vat, Short (open both ends) Spreader, Long (open both ends, no drain valve connection) Spreader, Short (open both ends, no drain valve connection)
8	809-0247	Nut, 8-32 Hex Keys
9	816-0625	Sleeve, Round Drain Connector
10	809-0969	Clamp, Round Drain Sleeve
11	810-2493	Elbow, 1/4-inch NPT X 90° Tube Compression
12	811-1071	Tube, 1/4-inch OD Teflon Manifold Vent
13	823-3879	Suction Tube, FootPrint Pro Female
14	810-1055	Flexline, 5/8-inch OD X 11.50-inch
15	810-1668	Adapter, 5/8-inch OD X 1/2-inch Male
16	813-0530	Tee, 1/2-inch X 1/2-inch X 1/4-inch Reducing
17	813-0838	Nipple, 1/4-inch NPT Close
18	807-2484	Solenoid Valve w/Female Pins
19	810-2773	Adapter, 1/2-inch OD Flare x 1/4-inch NPT
20	810-2787	Flexline, 1/2-inch OD X 5.00-inch
21	813-0165	Elbow, 1/2-inch NPT X 90° Street
22	810-1680	Flexline, 5/8-inch OD x 11.50-inch
23	813-0265	Nipple, 1/2-inch NPT X 2.50-inch
24	813-0342	Elbow, 1/2-inch NPT X 45° Street
25	813-0298	Nipple, 1/2-inch NPT X 2.00-inch
26	826-1264	Pump and Gasket Kit (for gasket only, order P/N 816-0093)
27		Motor and Gasket Kit, 50/60 Hz (for gasket only, order P/N 816-0093)
	826-1785 826-1712 826-1756 826-1270 826-1755	100V 115V 208V 220-240V 250V

2.4.2 Drain Valves and Associated Components

Non-Filter Drain Valve Assemblies

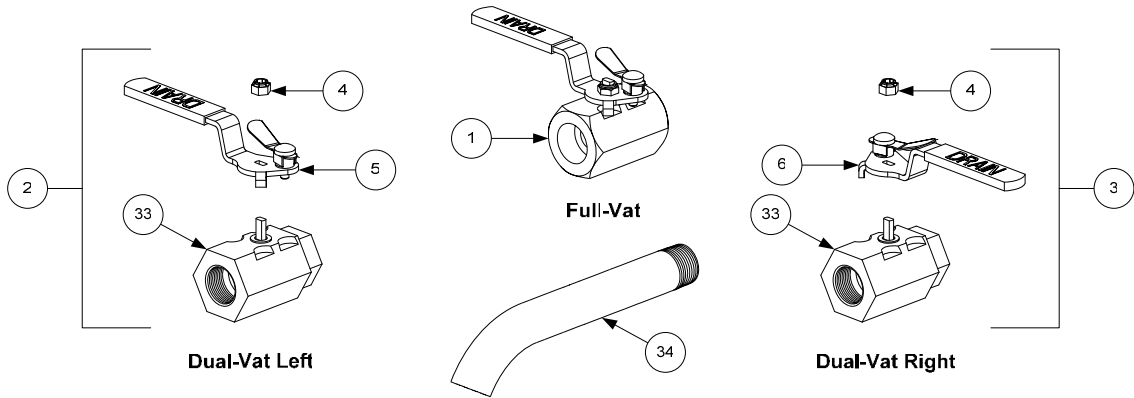

FootPrint Pro Drain Valve Assemblies

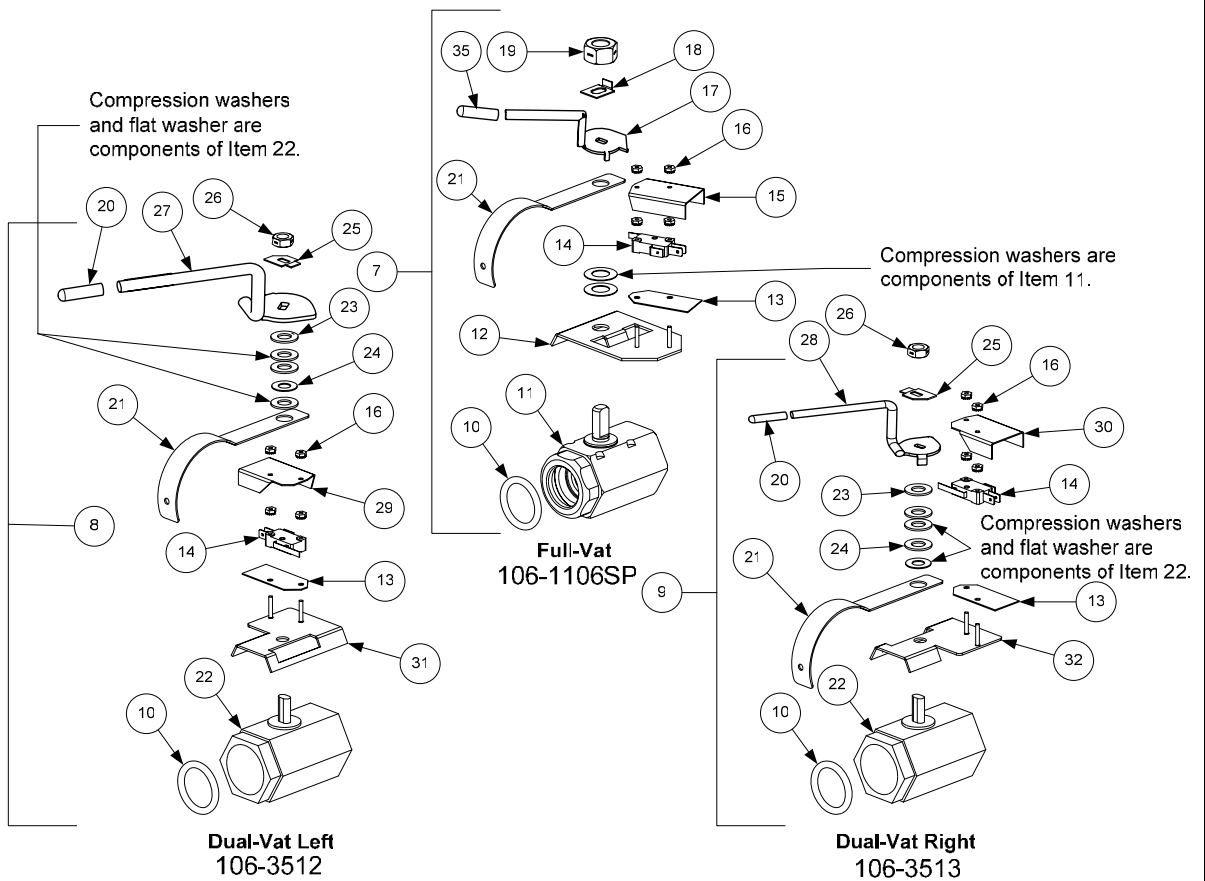

ITEM	PART #	COMPONENT
1	810-1569	Valve Assembly, 1.25-inch Full-Vat Non-Filter Drain (includes handle)
*	810-1427	Lock Pin Handle for 1.25-inch Valve Assembly
2	806-7915SP	Valve Assembly, 1-inch Left Dual-Vat Non-Filter Drain (complete assembly)
3	806-7916SP	Valve Assembly, 1-inch Right Dual-Vat Non-Filter Drain (complete assembly)
4	809-0589	Nut, ½-13 2-Way Lock (used on non-filter drain valves)
5	810-1568	Handle w/Lock Pin, Left Drain Valve
6	810-1567	Handle w/Lock Pin, Right Drain Valve
7	106-1106SP	Valve Assembly, 1.25-inch Full-Vat w/Filter Drain (complete assembly)
8	106-3512	Valve Assembly, 1-inch Left Dual-Vat w/Filter Drain (complete assembly)
9	106-3513	Valve Assembly, 1-inch Right Dual-Vat w/Filter Drain (complete assembly)
10	816-0135	O-Ring, Drain Valve
11	810-1018	Valve, 1.25-inch Drain
12	806-8137	Bracket Assembly, Drain Safety Switch
13	816-0220	Insulation, Drain Safety Switch
14	807-2103	Microswitch, Lever Activated
15	900-2841	Cover, Full-Vat Drain Safety Switch
16	826-1366	Nut, 4-40 Hex Keps (Pkg. of 25)
17	824-1602	Handle, Full-Vat Drain Valve
18	900-2936	Retainer, Full-Vat Drain Valve Nut
19	809-0540	Nut, ½-13 2-Way Lock
20	816-0677	Grip, Drain Valve Handle
21	200-6496	Support, 3-inch Drain Tube
22	810-1114	Valve, 1-inch Dual-Vat w/Filter Drain
23	809-0196	Washer, ⅜-inch Flat
24	810-1165	Washer, ⅜-inch Teflon
25	900-2934	Retainer, Dual-Vat Drain Valve Nut
26	809-0539	Nut, ⅜-16 2-Way Lock
27	823-4578	Handle, Left Dual-Vat Drain Valve
28	823-4577	Handle, Right Dual-Vat Drain Valve
29	901-2348	Cover, Left Dual-Vat Drain Safety Switch
30	902-2348	Cover, Right Dual-Vat Drain Safety Switch
31	106-2671	Bracket Assembly, Left Dual-Vat Drain Safety Switch
32	106-2672	Bracket Assembly, Right Dual-Vat Drain Safety Switch
33	810-1338	Valve, 1-Inch Dual-Vat Non-Filter Drain
34		Drain Valve Extension
	812-1226SP	Full-Vat (1.25-inch)
	812-1227	Dual-Vat (1-inch)
35	816-0639	Grip, Drain Valve Handle 5/16" x 3"

2.4.3 Rear Flush Oil Return Line Components

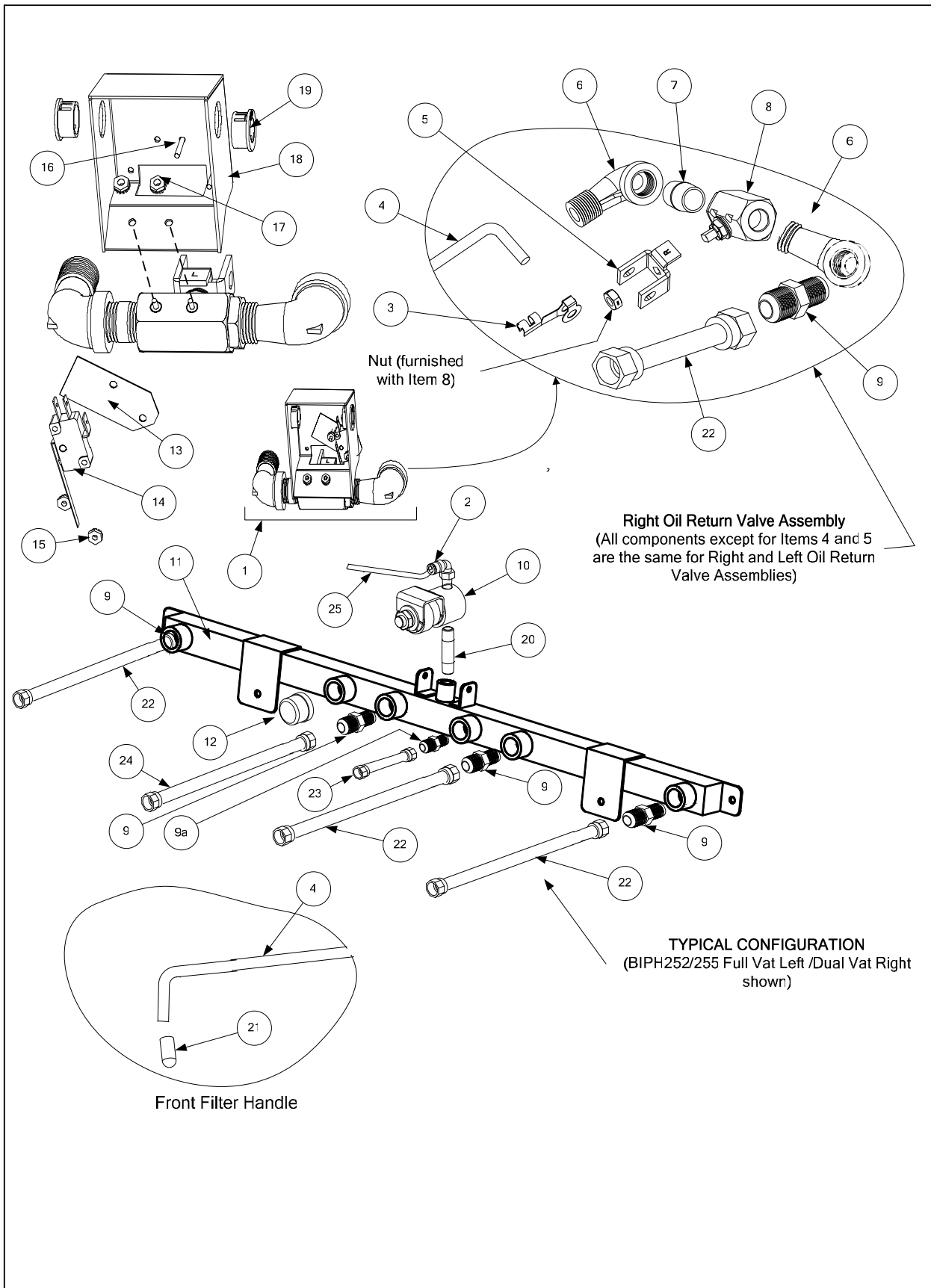

ITEM	PART #	COMPONENT
1		Valve Assembly, Microswitch and Ball Valve
	106-3452	Valve Rear Flush Assembly, Left Side
	106-3453	Valve Rear Flush Assembly, Right Side
2	810-2493	Elbow, 90° x ¼-inch
3	809-0601	Clip, Rod End Clevis
4		Shaft, Rear Flush Valve
	211-6701	For use in Left oil return valve assemblies.
	212-6701	For use in Right oil return valve assemblies.
5		Handle, Rear Flush Valve
	901-2772	For use in Left oil return valve assemblies.
	902-2772	For use in Right oil return valve assemblies.
6	813-0165	Elbow, 90° x ½-inch Street
7	813-0087	Nipple, 1½-inch BM NPT
8	810-2201	Valve, ½-inch Ball
*	900-2935	Oil Return Valve Nut Retainer
9	810-1668	Adapter, Male ⅝-inch Flexline to ½-inch NPT Male
9a	810-2786	Adaptor, ½-inch Flare x ½ -inch NPT
10	807-2484	Valve, ¼-inch NPT Solenoid Vent
11		Manifold, BIPH52 Rear Flush Oil Return
	810-2890	Two-Station Fryer
	810-2891	Three-Station Fryer
	810-2892	Four-Station Fryer
	810-2893	Five-Station Fryer
12	813-0156	Cap, ½-inch Pipe
13	816-0220	Insulation, Rear Flush Switch
14	807-4101	Microswitch, Lever Activated
15	826-1366	Nut, 4-40 Keps Hex (Pkg. of 25)
16	826-1359	Screw, 4-40 x ¾-inch Slotted Round Head (Pkg. of 25)
17	809-0250	Nut, 6-32 Keps Hex
18	200-8745	Cover, Microswitch Rear Flush
19	807-0125	Bushing, .50 ID Heyco SB-750-8 Nylon
20	813-0700	Nipple, ¼ NPT x 3-inch
21	816-0643	Grip, Oil Return Handle
22	810-1067	Flexline, ⅝-inch OD x 8.50-inch Oil Return
23	810-2787	Flexline, ½" x 5.00-inch Pump to Oil Return Manifold
24	810-1680	Flexline, ⅝-inch OD x 6.50-inch Oil Return Manifold to Pump
25	811-1071	Tube, ¼-inch OD Teflon Manifold Vent

2.5 Electronics and Electrical Components (for Controllers, Page 2-10)

2.5.1 Component Boxes

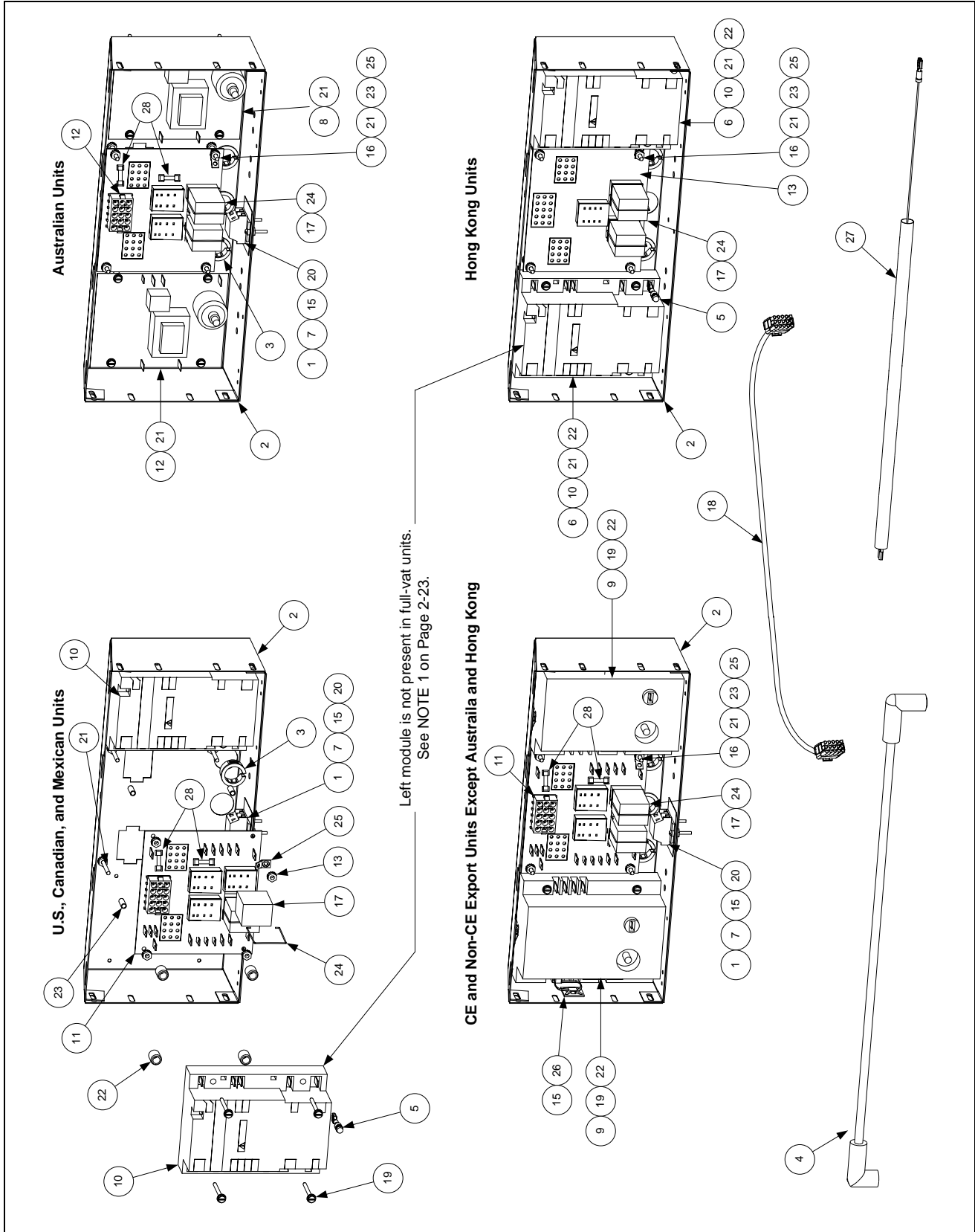

ITEM	PART #	COMPONENT
1	810-1164	Block, One-Piece Screwless Terminal
2	200-5996	Box, One-Piece Component
3	807-1926	Bushing, .875-inch Split
4	807-3483	Cable, 21-inch Ignition H50/H52 –For 807-3366/3365 Modules
*	826-2024	Cable, Ignition - 1 wire / 1 rajah
*	826-1721	Cable, Ignition – 2 wire / 2 rajah
5	807-3484	Connector, Rajah
6	106-0531SP	Fuse Assembly, Inline
7	816-0217	Insulation, Terminal Block Paper
8	807-2971	Ignition Module, Australian
9	807-1006	Ignition Module, CE and Non-CE export (<i>except Australia, Canada, HK, Mexico</i>)
10	807-3366†	Ignition Module, Dual-Spark Full-Vat (<i>U.S., Canadian, HK, and Mexican units</i>)
	807-3365†	Ignition Module, Single-Spark Ignition Module Dual-vat (<i>U.S., Canadian, HK, and Mexican units</i>)
11	826-2264	Interface Board Kit; U.S., CE and non-CE (<i>except Hong Kong</i>)
	106-6706	Interface Board SMT, U.S., CE and non-CE (<i>except Hong Kong</i>)
	807-4330	Sound Device/Speaker Adapter Harness SMT
	807-4343	Wire Harness, SMT Interface Board to Ignition Module
12	106-0387	Interface Board, Australian
13	806-4973	Interface Board, Hong Kong
14	807-1359	Mount, Ty-Wrap
15	826-1366	Nut, 4-40 Keps Hex (Pkg. of 25)
16	809-0250	Nut, 6-32 Keps Hex
17	807-0833	Relay, DPDT 5A 12VDC Latch (See NOTE 1.)
18	806-2071	Cable, 15-pin Computer to Interface Board
19	809-0441	Screw, #8 X 1½-inch Hex Washer Head
20	826-1359	Screw, 4-40 X ¾-inch Slotted Round Head (Pkg. of 25)
21	809-0098	Screw, 6-32 X 1¼-inch Slotted Round Head
22	826-1346	Spacer, Ignition Module (Pkg. of 10)
23	810-2763	Spacer, Interface Board
24	810-2243	Spring, Relay Retaining
25	826-1337	Tab, ¼-inch Terminal (Pkg. of 5)
26	807-1948	Ty-Wrap
27	806-6085SP	Wire Assembly, Ignition Module
28	807-3843	Fuse 3A 250V Domestic
	807-3293	Fuse 5A 125V International Only
*	807-1200	Ignition Wire, 27”
*	807-1878	Ignition Wire, 19”
*	807-3520	Sound Device, High Output

* Not illustrated.

† For Dual-vat units, use 807-3365 Single Spark Ignition Module (see **NOTE 1**).

NOTE 1: U.S., Canadian, Hong Kong, and Mexican units use two different modules depending upon the configuration of the frypot. Dual-Vat units use two 807-3365 Single-Spark Ignition Modules. Full-Vat units use one 807-3366 Dual-Spark Ignition Module. Also, in full-vat units, only one latch relay (Item 17) is used, located in the lower right socket.

2.5.2 Transformer Boxes

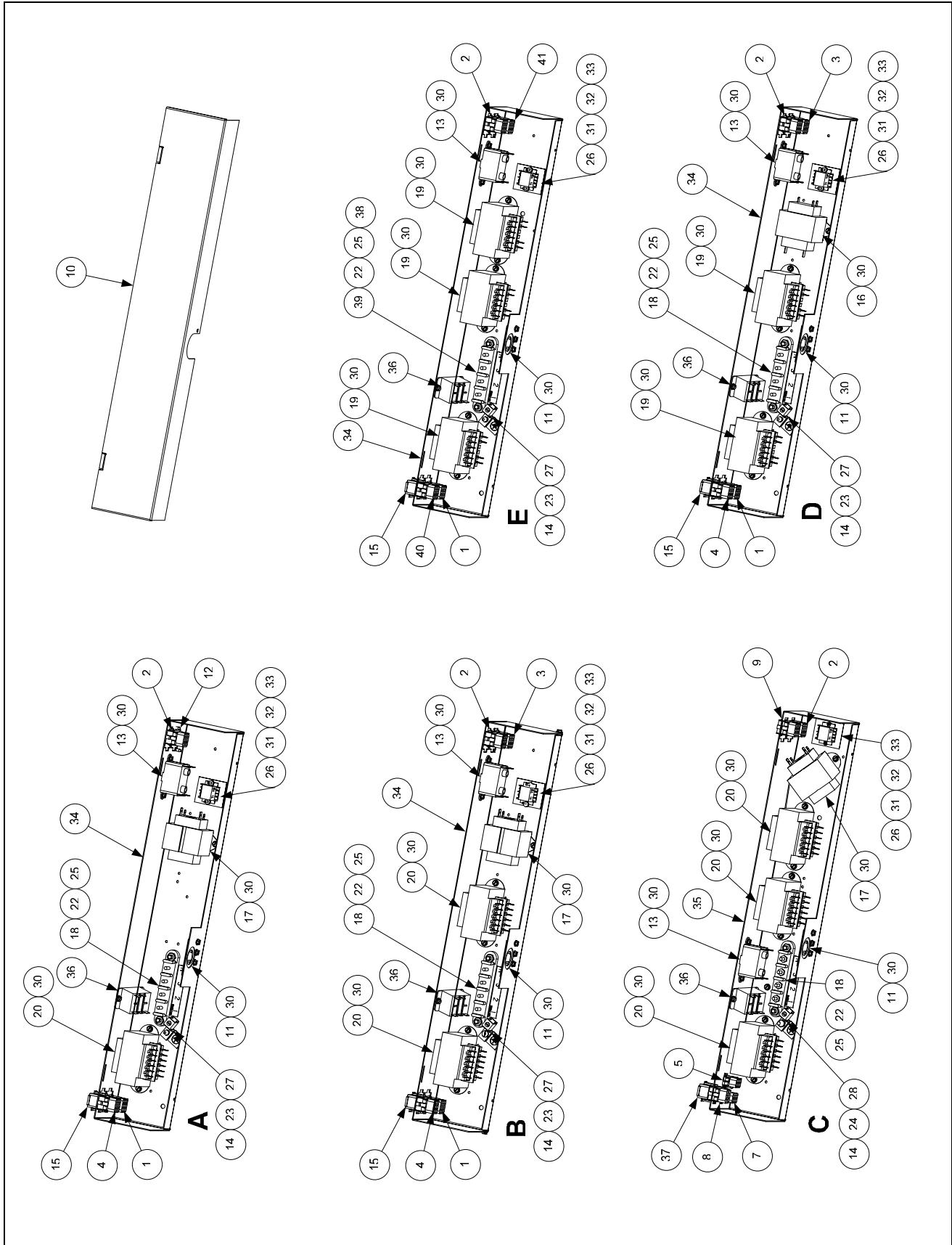

2.5.2 Transformer Boxes Continued

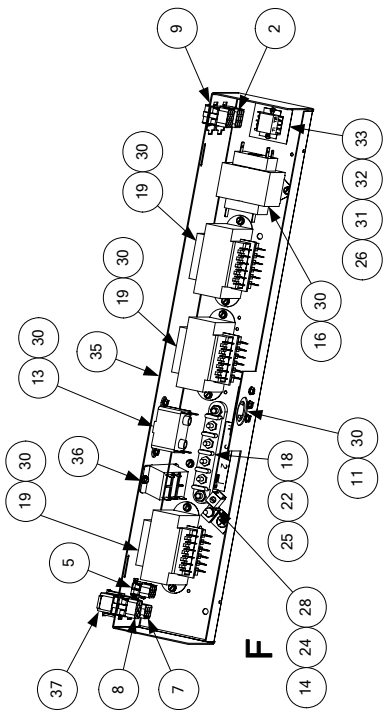
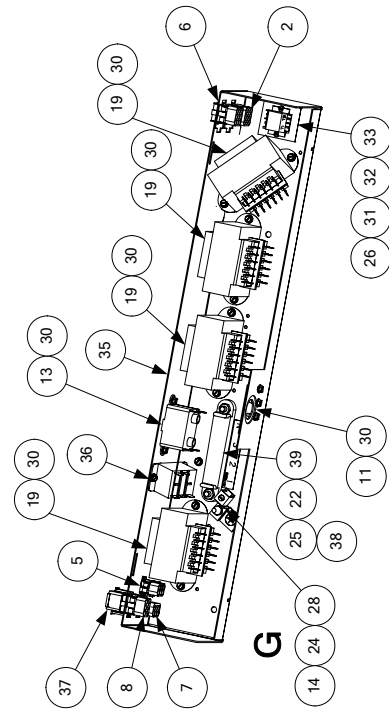

ITEM	PART #	COMPONENT
		Box Assembly, Transformer
A	106-1380	100-120V FMPH152/155, FMPH352/355, FMPH452/455
B	106-3818	100-120V BIPH 252/255, BIPH 452/455, FMPH252/255
C	106-4888	100-120V BIPH 352/355
D	106-3819	208-240V BIPH 252/255 and BIPH 452/455 CE/Non-CE Export
E	106-3817	250V BIPH 252 and BIPH 452 CE/Non-CE Export
F	106-3824	208-240V BIPH 352/355 CE/Non-CE Export
G	106-3823	250V BIPH 352/355 CE/Non-CE Export
1	106-3820	Cable Assembly, Transformer Box #1
2	106-3821	Cable Assembly, Transformer Box #2
3	106-1011	Cable Assembly, Transformer Box Line
4	106-1016	Cable Assembly, Transformer Box Filter Pump
5	106-3827	Cable Assembly, Transformer Box #1 (On Box G this PN# becomes 106-4898)
6	106-4990	Cable Assembly, Transformer Box Line
7	106-3825	Cable Assembly, Transformer Box #3
8	106-3826	Cable Assembly, Transformer Box Filter Pump
9	106-3316	Cable Assembly, Transformer Box Line
10	200-1415	Cover, Transformer Box
11	200-6721	Plate, Strain Relief
12	200-2318	Cover, Transformer Box Cable Plate
13	807-0012	Relay, 18 Amp 1/3-HP 24V Coil
14	807-0070	Terminal, Ground Lug
15	807-0155	Connector, 9-Pin Male
16	807-0680	Transformer, 208-240V/24VAC 50/60Hz 20VA
17	807-0800	Transformer, 100-120V/24VAC 50/60Hz 50VA (On Box C PN# is 807-1238)
18	807-1973	Terminal, Post
19	807-1999	Transformer, 208-240V V/F Dual Voltage
20	807-2176	Transformer, 100-120V V/F Dual Voltage
21	809-0052	Nut, 10-24 Hex
22	826-1362	Nut, 1/4-20 Hex (Pkg. of 10)
23	826-1363	Screw, 8-32 X 1/2-inch Slotted Truss Head (Pkg. of 25)
24	809-0123	Screw, 10-24 X 3/4-inch Slotted Truss Head
25	826-1389	Screw, 1/4-20 X 3/4-inch Hex Head (Pkg. of 10)
26	826-1366	Nut, 4-40 Keps Hex (Pkg. of 25)
27	809-0247	Nut, 8-32 Keps Hex
28	826-1376	Nut, 10-32 Keps Hex (Pkg. of 10)
29	826-1359	Screw, 4-40 X 3/4-inch Slotted Round Head (Pkg. of 25)
30	809-0360	Screw, #8 X 3/8-inch Hex Washer Head
31	809-0656	Screw, 4-40 X 3/8-inch Slotted Round Head
32	810-1164	Block, One-Piece Screwless Terminal
33	816-0217	Insulation, Terminal Block Paper
34	824-1242	Box, Transformer BIPH252, 452
35	824-1301	Box, Transformer BIPH352, 552
36	807-1683	Relay, Hood 12V DC
37	807-0157	Connector, 6-Pin Male
38	816-0219	Paper, CE Triple Terminal Block Insulating
39	810-1163	Block, 3 Places Screwless Terminal
40	106-4894	Cable Assembly, Transformer Box Filter Pump
41	106-4893	Cable Assembly, Transformer Box Line

Continued on Next Page

Continued from Previous Page		
ITEM	PART #	COMPONENT
*	WIR 0623	Wire Assembly, PH52 Hood Relay
*	WIR0634	Wire Assembly, FPP50 Transformer/Filter Box (used in Item E)
*	WIR0635	Wire Assembly, FPPH350 Transformer Filter Box (used in Item G)
*	WIR0439	Wire Assembly, Transformer Box (used in Items B, D, and E)
*	WIR0447	Wire Assembly, Transformer Box (used in Item A)
*	WIR0580	Wire Assembly, Transformer Box (used in Item C)

* Not illustrated

2.5.3 High-Limit Thermostat and Temperature Probe

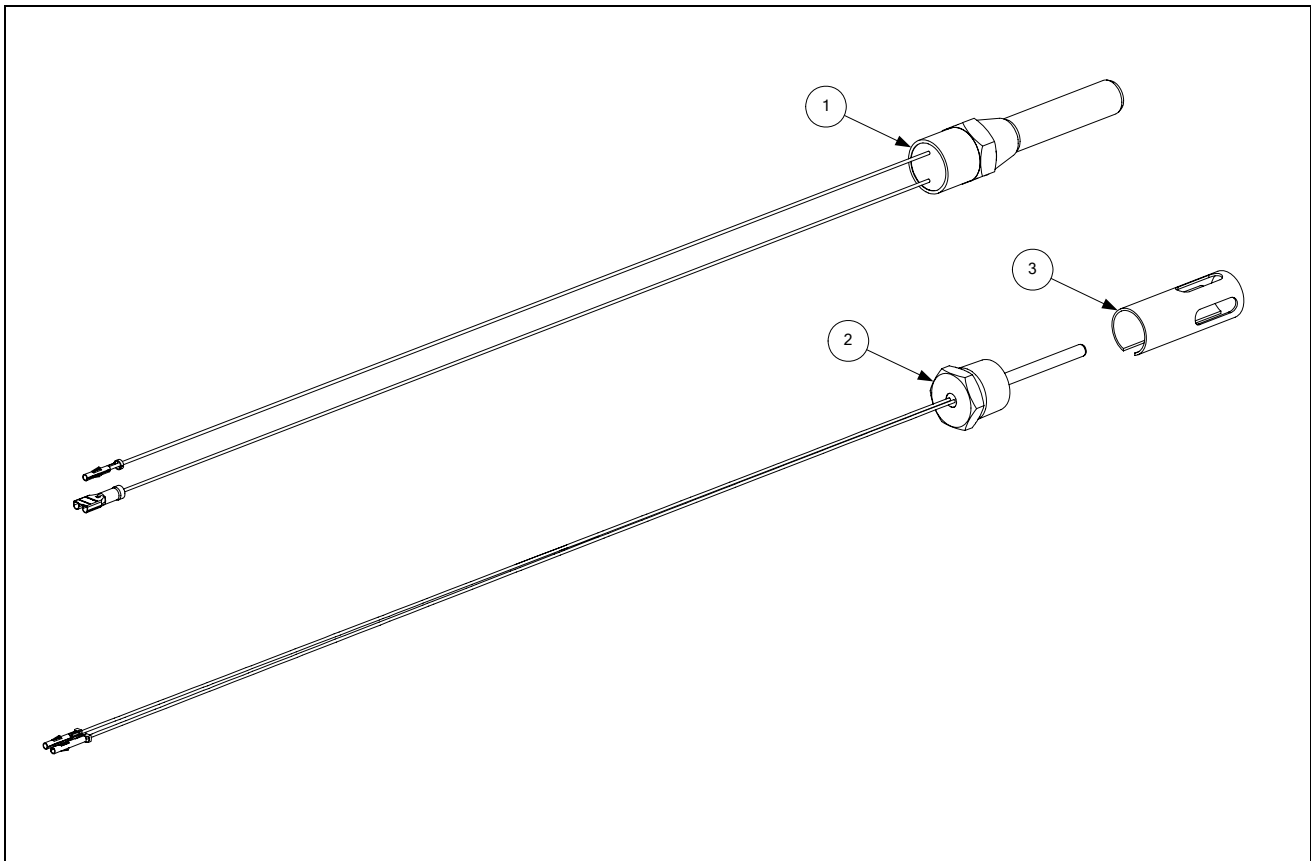

ITEM	PART #	COMPONENT
1	826-1177	Thermostat Assembly, HE FM High-Limit 425°F/218°C
2	806-4206	Temperature Probe
3	210-0681	Probe Guard

2.7 Frypots and Associated Components

2.7.1 Full-Vat Frypot Components

NOTE: All insulation and gaskets can be ordered in a single kit, P/N 826-0929.

Kit 826-0931 contains the insulation and gaskets required when replacing burners (Items 14, 16, 18, and 23).

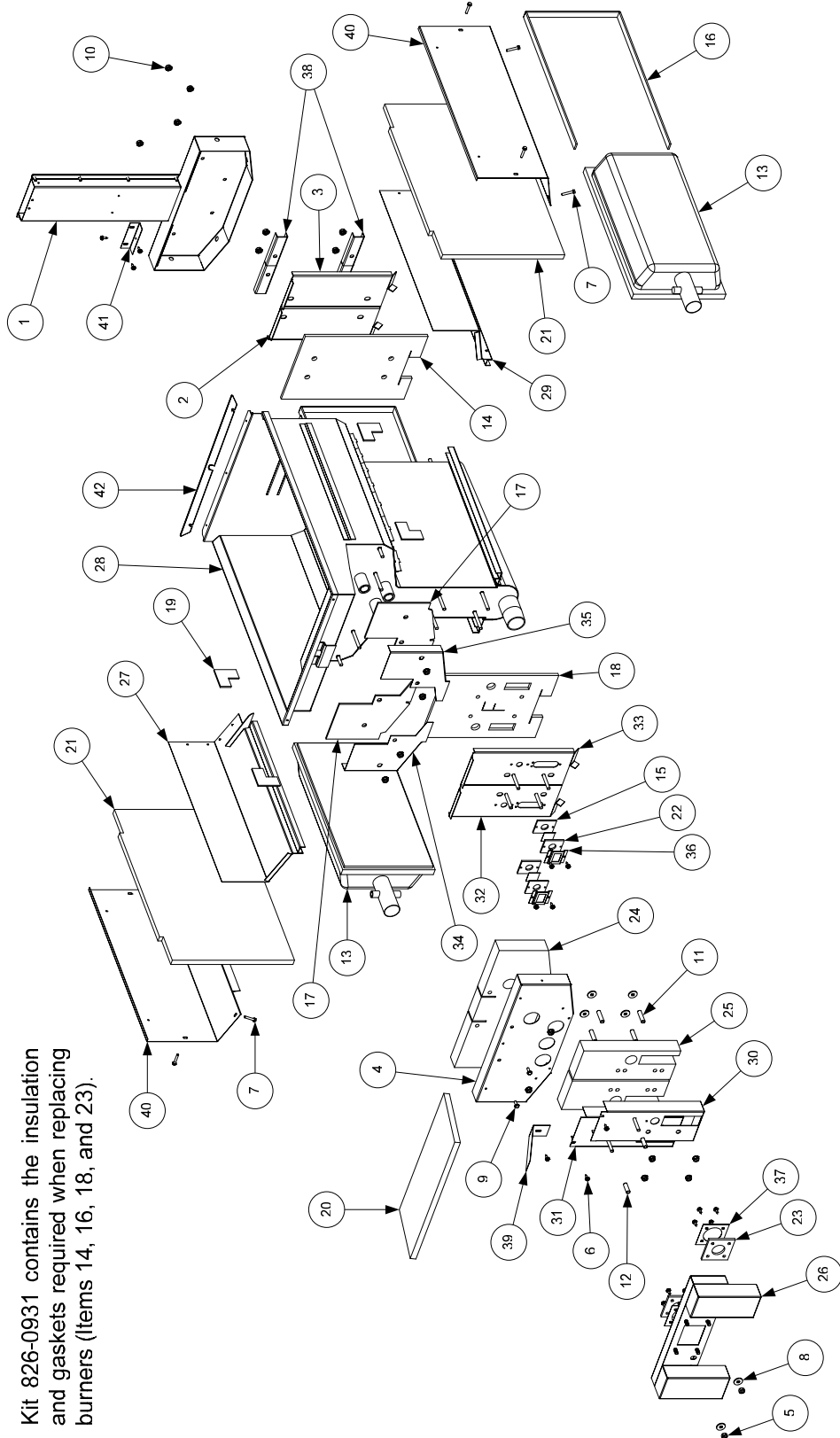

ITEM	PART #	COMPONENT
1	106-1019SP	Flue Assembly, Full-Vat
2	200-0936	Back, Left Full-Vat Combustion Chamber
3	200-0937	Back, Right Full-Vat Combustion Chamber
4	200-2227	Retainer, Full-Vat Upper Insulation
5	826-1372	Nut, ¼-20 Flange Hex (Pkg. of 10)
6	826-1371	Screw, #8 X ½-inch Hex Head Drill Point (Pkg. of 25)
7	809-0362	Screw, #8 X 1¼-inch Hex Washer Head Drill Point
8	826-1383	Washer, Steel (Pkg. of 5)
9	809-0500	Screw, #10 X ½-inch Hex Washer Head 410 SS
10	809-0804	Nut, ¼-20 Keps Hex
11	826-1340	Spacer, .25-inch X 1.187-inch (Pkg. of 10)
12	810-0500	Spacer, .25-inch X .9375-inch
13	826-1072	Burner, Universal Replacement
14	812-0355	Insulation, Full-Vat Lower Rear
15	812-0356	Insulation, Burner Sight Glass
16	816-0577	Insulation, Burner
17	812-0404	Insulation, Left or Right Front Seal
18	812-0457	Insulation, Full-Vat Lower Front
19	812-0706	Insulation, Upper Burner Rail
20	812-0993	Insulation, Upper Oil Zone
21	812-1029	Insulation, Combustion Chamber Side
22	814-0048SP	Glass, Burner Sight
23	816-0057	Gasket, Plenum
24	816-0560	Insulation, Full-Vat Upper Front
25	816-0561	Insulation, Left or Right Outer Front
26	823-0969	Plenum, Full-Vat
27	823-1777	Side and Rail, Left Full-Vat Combustion Chamber
28	823-3323SP	Frypot, Full-Vat 439 SS
29	823-3142	Side and Rail, Right Full-Vat Combustion Chamber
30	823-3304	Front, Full-Vat Right Combustion Chamber
31	823-3305	Front, Full-Vat Left Combustion Chamber
32	823-3315	Retainer, Left Full-Vat Lower Front Insulation
33	823-3316	Retainer, Right Full-Vat Lower Front Insulation
34	824-0863	Retainer, Left Full-Vat Upper Insulation
35	824-0864	Retainer, Right Full-Vat Upper Insulation
36	900-1031	Retainer, Burner Sight Glass
37	900-1049	Retainer, Plenum Gasket
38	900-1221	Retainer, Rear Insulation
39	900-1515	Brace, Upper Oil Zone Insulation
40	900-4452	Retainer, Combustion Chamber Side Insulation
41	930-0818	Bracket, Flue to Frypot
42	900-4253	Strip, Fluecap Retainer
*	910-2474	Pot-to-Pot Gap Clip
*	106-1049SP	Frypot Assembly Full-Vat w/RF HE (NAT)
*	106-1050SP	Frypot Assembly Full-Vat w/RF HE (PRO)
*	106-1053	Frypot Assembly Full-Vat w/RF HE (MFG)
*	826-0929	Insulation Kit, Complete Full-Vat
*	826-0931	Insulation Kit, Burner Full-Vat

* Not Illustrated

2.7.2 Dual-Vat Frypot Components

NOTE: All insulation and gaskets can be ordered in a single kit, P/N 826-0930.

Kit 826-0932 contains the insulation and gaskets required when replacing burners (Items 13, 15, 17, and 23).

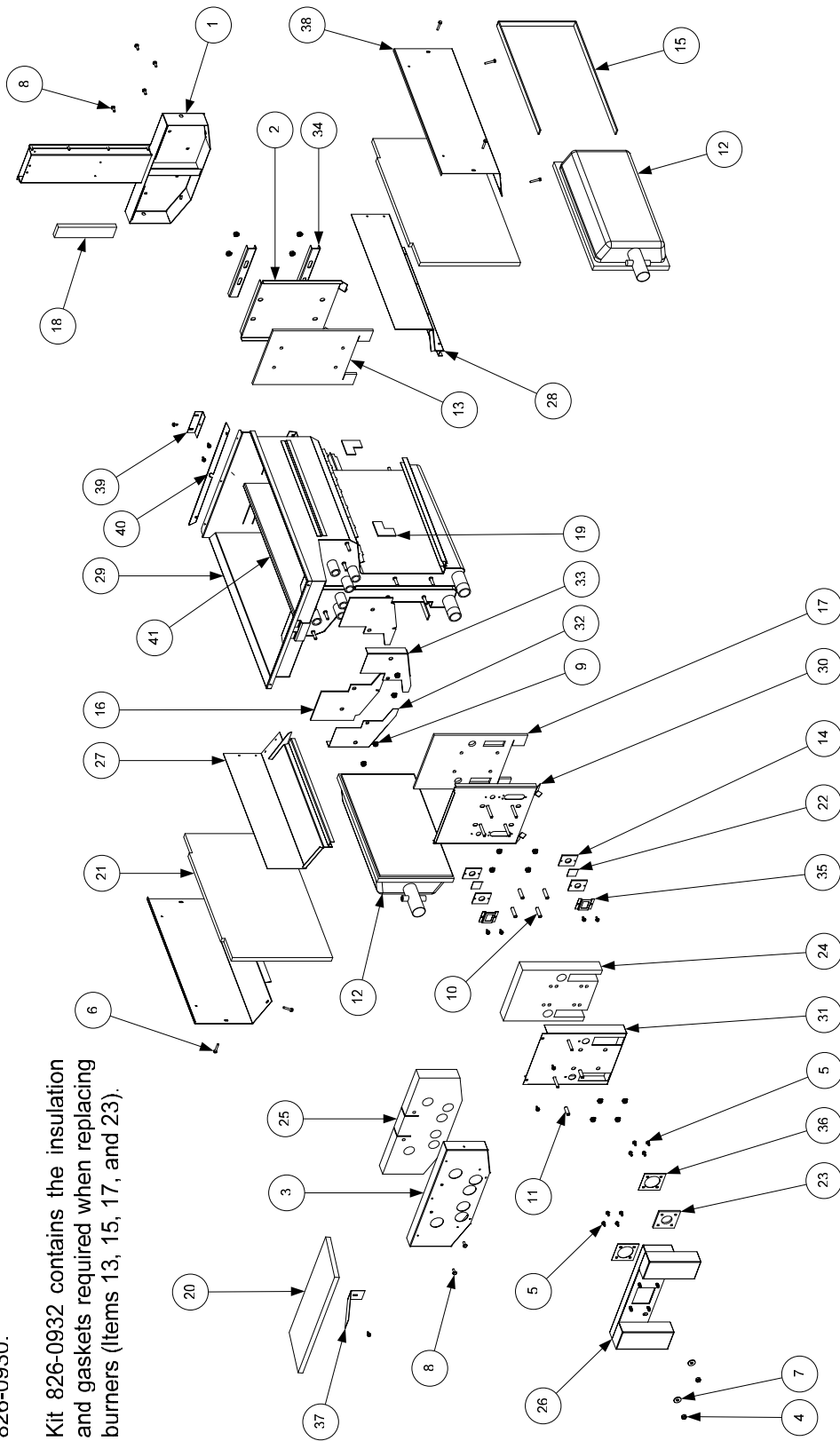

ITEM	PART #	COMPONENT
1	106-1018SP	Flue Assembly, Dual-Vat
2	200-0941	Back, Dual-Vat Combustion Chamber
3	200-2229	Retainer, Dual-Vat Upper Insulation
4	826-1372	Nut, ¼-20 Flange Hex (Pkg. of 10)
5	809-0360	Screw, #8 X ⅜-inch Hex Head
6	809-0362	Screw, #8 X 1¼-inch Hex Washer Head Drill Point
7	826-1383	Washer, Steel (Pkg. of 5)
8	809-0500	Screw, #10 X ½-inch Hex Washer Head 410 SS
9	809-0804	Nut, ¼-20 Keps Hex
10	826-1340	Spacer, .25-inch X 1.187-inch (Pkg. of 10)
11	810-0500	Spacer, .25-inch X .9375-inch
12	826-1072	Burner, Universal Replacement
13	812-0354	Insulation, Dual-Vat Lower Rear
14	812-0356	Insulation, Burner Sight Glass
15	816-0577	Insulation, Burner
16	812-0404	Insulation, Left or Right Front Seal
17	812-0458	Insulation, Dual-Vat Lower Front
18	812-0688	Insulation, Flue Collector
19	812-0706	Insulation, Upper Burner Rail
20	812-0993	Insulation, Upper Oil Zone
21	812-1029	Insulation, Combustion Chamber Side
22	814-0048SP	Glass, Burner Sight
23	816-0057	Gasket, Plenum
24	816-0558	Insulation, Dual-Vat Lower Front
25	816-0559	Insulation, Dual-Vat Upper Front
26	823-0970	Plenum, Dual-Vat
27	823-2822	Side and Rail, Left Dual-Vat Combustion Chamber
28	823-2823	Side and Rail, Right Dual-Vat Combustion Chamber
29	823-3324SP	Frypot, Dual-Vat 439 SS
30	823-3302	Front, Dual-Vat Combustion Chamber
31	823-3303	Retainer, Dual-Vat Lower Front Insulation
32	824-0865	Retainer, Left Dual-Vat Upper Insulation
33	824-0866	Retainer, Right Dual-Vat Upper Insulation
34	900-0914	Retainer, Lower Rear Insulation
35	900-1031	Retainer, Burner Sight Glass
36	900-1049	Retainer, Plenum Gasket
37	900-1515	Brace, Upper Oil Zone Insulation
38	900-4452	Retainer, Combustion Chamber Side Insulation
39	930-0818	Bracket, Flue to Frypot
40	900-4253	Strip, Fluecap Retainer
41	824-0541	Riser, DV Pot Divider W/A
*	910-2474	Pot-to-Pot Gap Clip
*	106-1079SP	Frypot Assembly Dual-Vat w/RF HE (NAT)
*	106-1080SP	Frypot Assembly Dual-Vat w/RF HE (PRO)
*	106-1070	Frypot Assembly Dual-Vat w/RF HE (MFG)
*	826-0930	Insulation Kit, Complete Dual-Vat
*	826-0932	Insulation Kit, Burner Dual-Vat

* Not Illustrated

2.8 Gas Supply and Combustion System Components

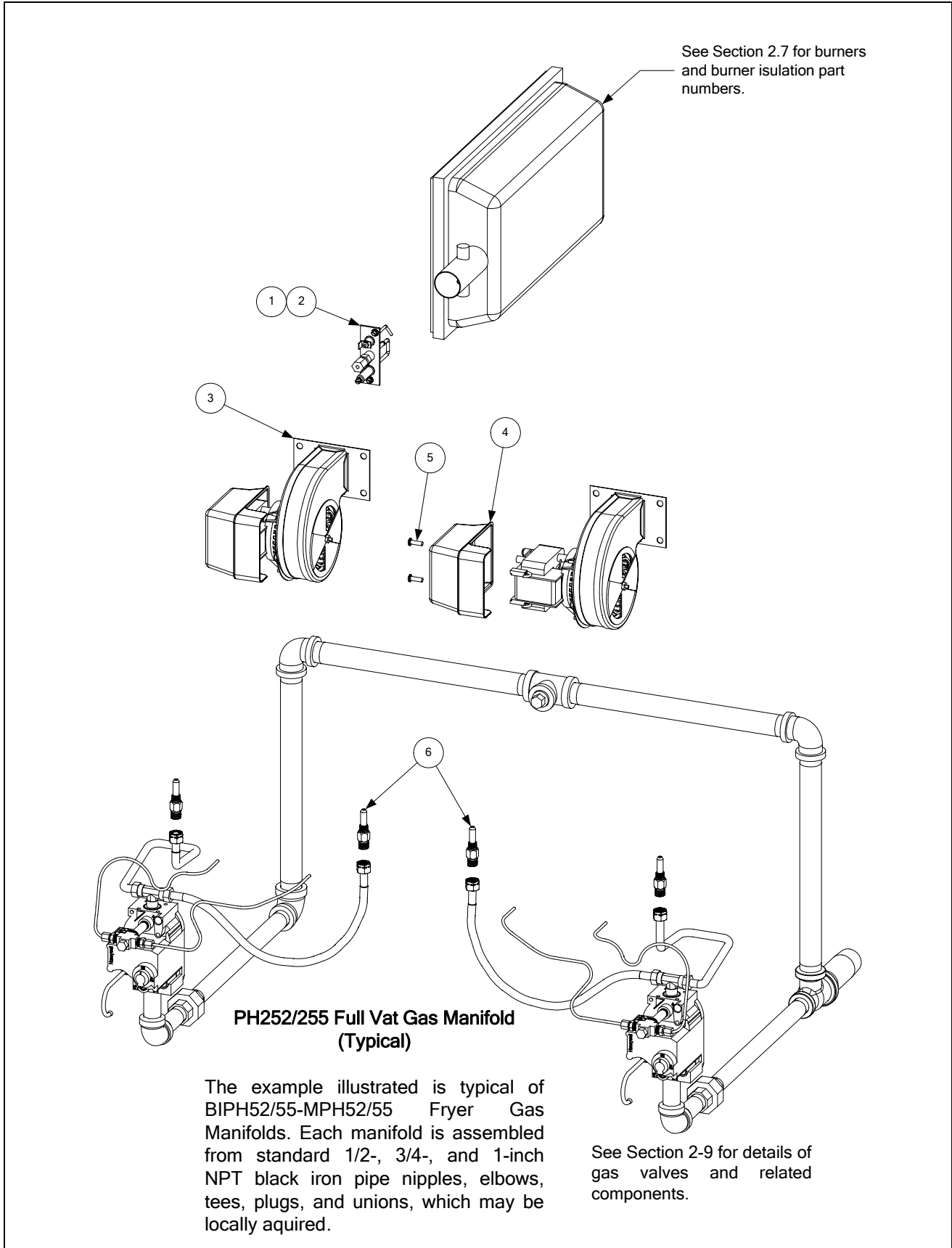

ITEM	PART #	COMPONENT
1		Ignitor (includes gasket 816-0059, which may be ordered separately)
	826-0981	Natural Gas (G20, G25)
	826-0982	Propane (G30, G31)
	826-1002	Manufactured Gas
2	826-1371	Screw, #8 X ½-inch Hex Head (Pkg. of 25)
3		Blower Assembly, Combustion Air (includes harness and Items 4, and 5)
	106-2996SP	100V 50/60 Hz (Left)
	106-2999SP	100V 50/60 Hz (Right)
	106-2994SP	115V 50/60 Hz. (Left)
	106-2997SP	115V 50/60 Hz (Right)
	106-2995SP	208-240V 50/60 Hz (Left)
	106-2998SP	208-240V 50/60 Hz (Right)
	106-3000SP	230V 50/60 Hz CE (Left)
	106-3001SP	230V 50/60 Hz CE (Right)
4	816-0554	Cover, Blower Motor (component of all blowers listed above)
5	809-0938	Screw, 10-32 X ⅝-inch Philips Truss Head (secures Item 4 to Item 3)
*	806-8806SP	Harness Assembly, Blower Motor (component of all blowers listed above)
6		Orifice, Burner
	812-1137	1.95 mm Propane/Butane (G30, G31) (0-4999 Ft, 0-1524 M) (CE)
	810-1221	2.00 mm Propane/Butane (0-4999 Ft, 0-1524 M) (Japan only)
	810-0386	2.10 mm Propane/Butane (0-4999 Ft, 0-1524 M)
	810-0413	2.16 mm Propane/Butane (G30, G31) (5000-6999 Ft, 1525-2133 M)
	812-1028	2.20 mm Propane/Butane (G30, G31) (7000-10,999 Ft, 2134-3352 M)
	812-1134	3.10 mm Natural Gas (G20, G25) (0-4999 Ft, 0-1524 M) (Japan only)
	810-0403	3.40 mm Natural Gas (G20, G25) (0-4999 Ft, 0-1524 M)
	810-0437	3.60 mm Natural Gas (G20, G25) (5000-6999 Ft, 1525-2133 M)
	812-1144	3.65 mm Natural Gas (G20, G25) (7000-8999 Ft, 2134-2743 M)
	812-1145	3.70 mm Natural Gas (G20, G25) (9000-10,999 Ft, 2744-3352 M)
	810-0642	5.95 mm Manufactured Gas (0-4999 Ft, 0-1524 M)
*	826-1196	Conversion Kit, Natural Gas (G20, G25) to Propane/Butane (G30, G31) CE only
*	826-1197	Conversion Kit, Propane/Butane (G30, G31) to Natural Gas (G20, G25) CE only
*	807-2263	Switch, Air Pressure (<i>use 807-2262 in units with 100VAC power supply</i>)

* Not illustrated.

2.9 Gas Valves and Associated Components

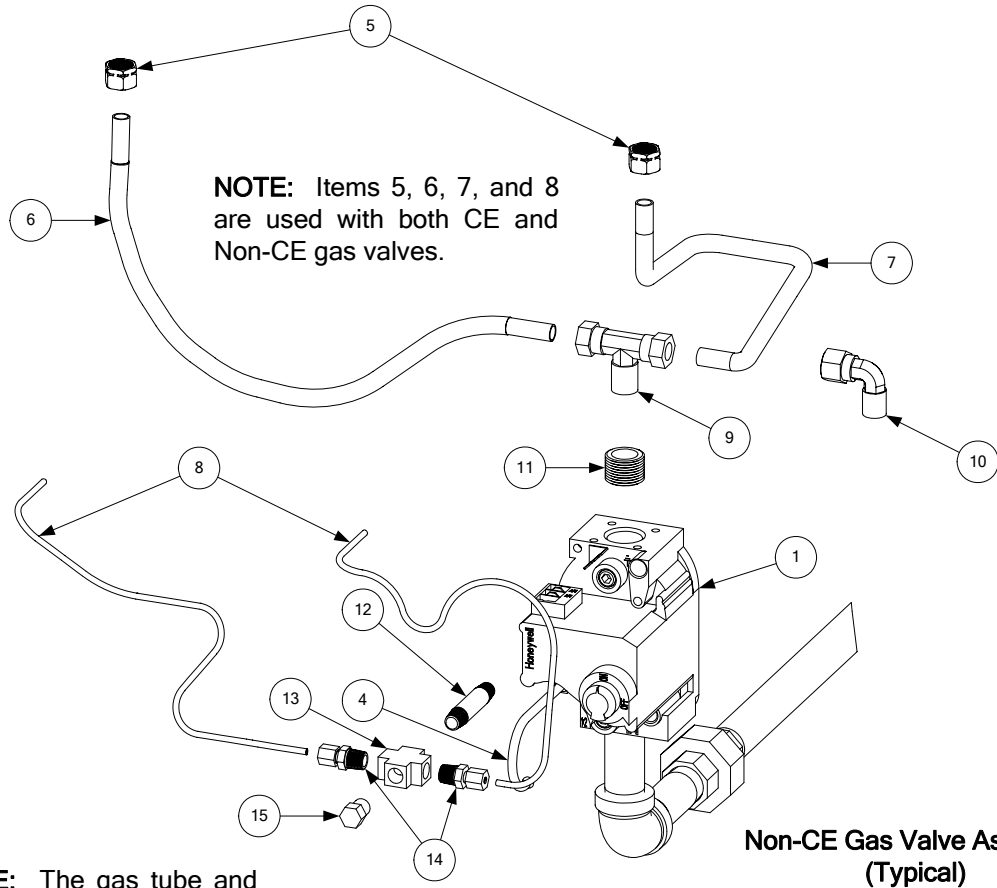

**Non-CE Gas Valve Assembly
(Typical)**

NOTE: The gas tube and enrichment tube fittings are assembled in varying configurations depending upon the location of the valve and whether the associated frypot is a full- or a dual-vat pot.

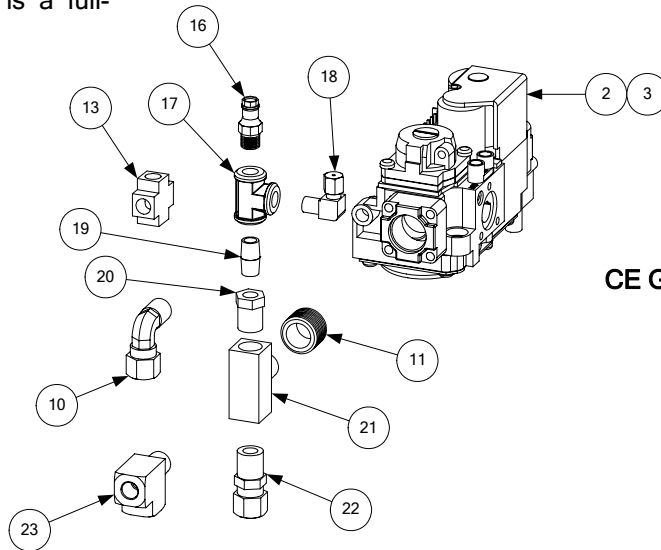

**CE Gas Valve Assembly
(Typical)**

ITEM	PART #	COMPONENT
1		Valve, Non-CE Gas
	826-1122	Natural Gas (G20, G25)
	826-1120	Kit Natural Gas w/ flexlines and hardware
	826-1123	Propane Gas (G30, G31)
	826-1121	Kit, Propane Gas w/ flexlines and hardware
2	810-1715	Valve, CE Gas (G20, G25, G30, G31)
3	810-1041	Accessory Kit (contains parts to adapt Item 2 to specific fryer configuration)
4	810-0691	Tube, 1/8-inch Vent
5	810-0494	Ferrule (Nut), Orifice
6	810-1355	Gas Line, 3/8-inch OD X 15-inch SS Flexible
7	810-1354	Gas Line, 3/8-inch OD X 12-inch SS Flexible
	810-1353	Gas Line, 3/8-inch OD X 9-inch SS Flexible (Used on some split pot applications)
8	811-0800	Tube, 1/8-inch OD X 12.5-inch Enrichment (cut and form to fit)
9	813-0301	Tee, 1/4-inch Male NPT to 3/8-inch Tube
10	813-0302	Elbow, 1/4-inch Male NPT to 3/8-inch Tube 90° (used on DV valve)
11	813-0304	Bushing, 1/2-inch NPT to 1/4-inch NPT Flush Reducing
12	813-0405	Nipple, 1/8-inch NPT X 2-inch
13	813-0378	Fitting, 1/8-inch NPT Cross
14	813-0340	Adapter, 1/8-inch NPT to 1/8-inch Tube
15	813-0154	Plug, 1/8-inch NPT Hex Head Pipe
16	810-1176	Tap, 1/8-inch NPT Pressure
17	813-0377	Tee, 1/8-inch NPT Female
18	813-0354	Elbow, 1/8-inch NPT X 1/8-inch Tube Compression
19	813-0016	Nipple, 1/8-inch NPT X Close
20	810-1006	Bushing, 1/4-inch NPT to 1/8-inch NPT Reducing
21	813-0495	Tee, 1/4-inch Male NPT to Female NPT
22	810-1025	Connector, 1/4-inch Male NPT to 3/8-inch Tube
23	810-1026	Tee, 1/4-inch Male NPT to Female NPT Street

2.10 Wiring Assemblies and Harnesses

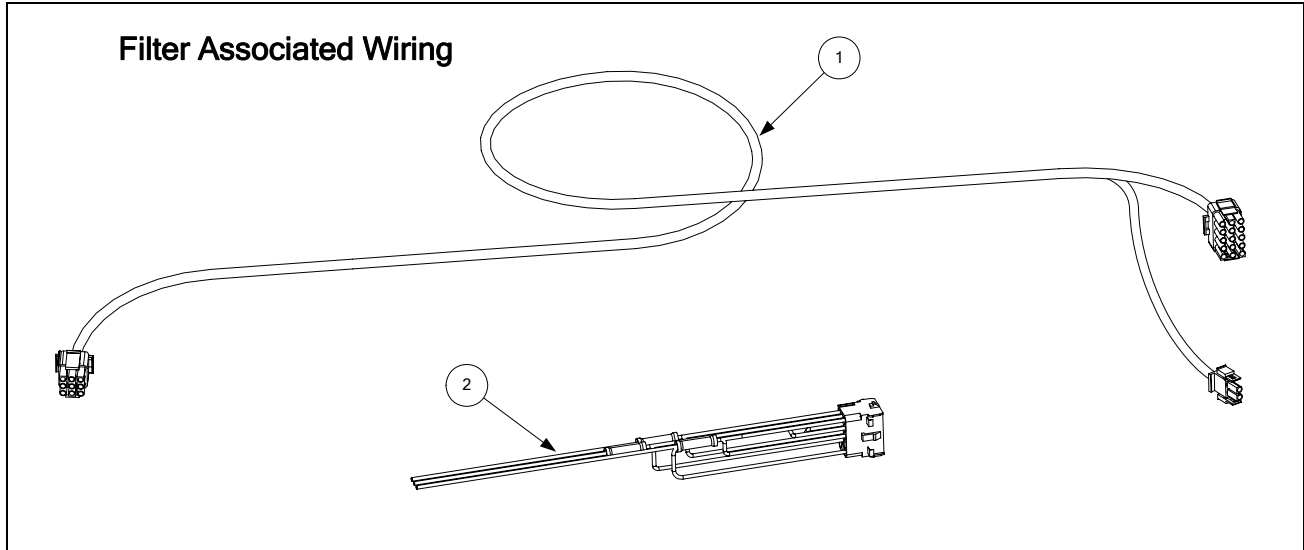

ITEM	PART #	COMPONENT
1	807-3584	Cable, Filter Lower 9-Pin Plug to 807-2001 15-Pin (C2) Connector
2	807-2001	Cable, 810-3584 15-Pin C2 Connector to Component Box

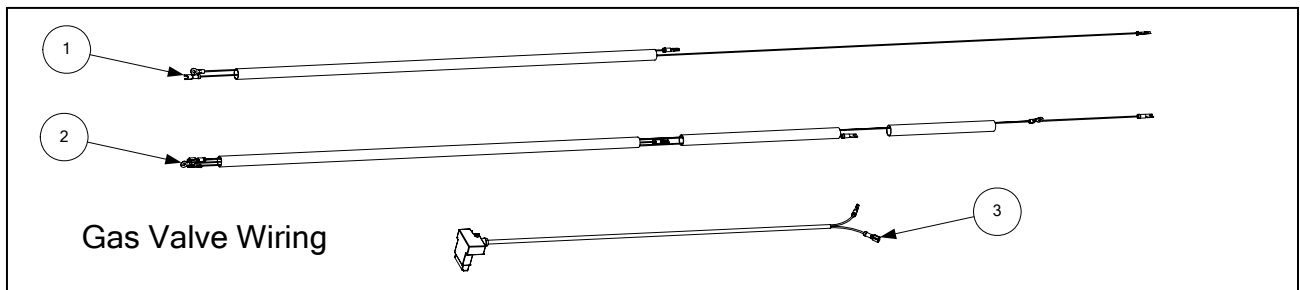

ITEM	PART #	COMPONENT
1	806-3941SP	Harness, Full Vat Gas Valve
2	806-3940SP	Harness, Dual Vat Gas Valve
3	806-9678SP	Plug Assembly, CE Gas Valve

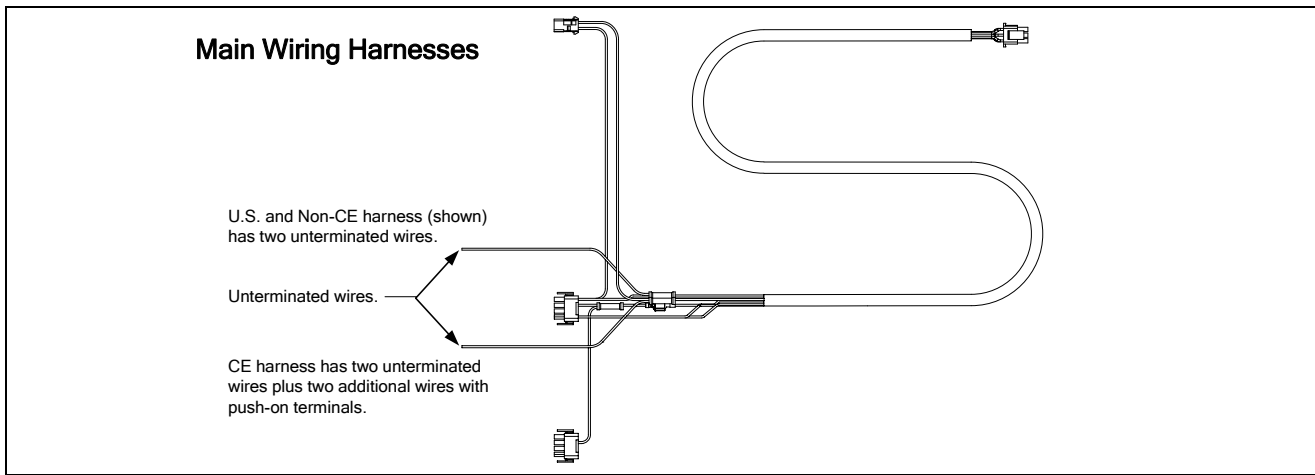

ITEM	PART #	COMPONENT
	807-1978	U.S. and Non-CE Export Main Wiring Harness
	807-2168	CE Main Wiring Harness

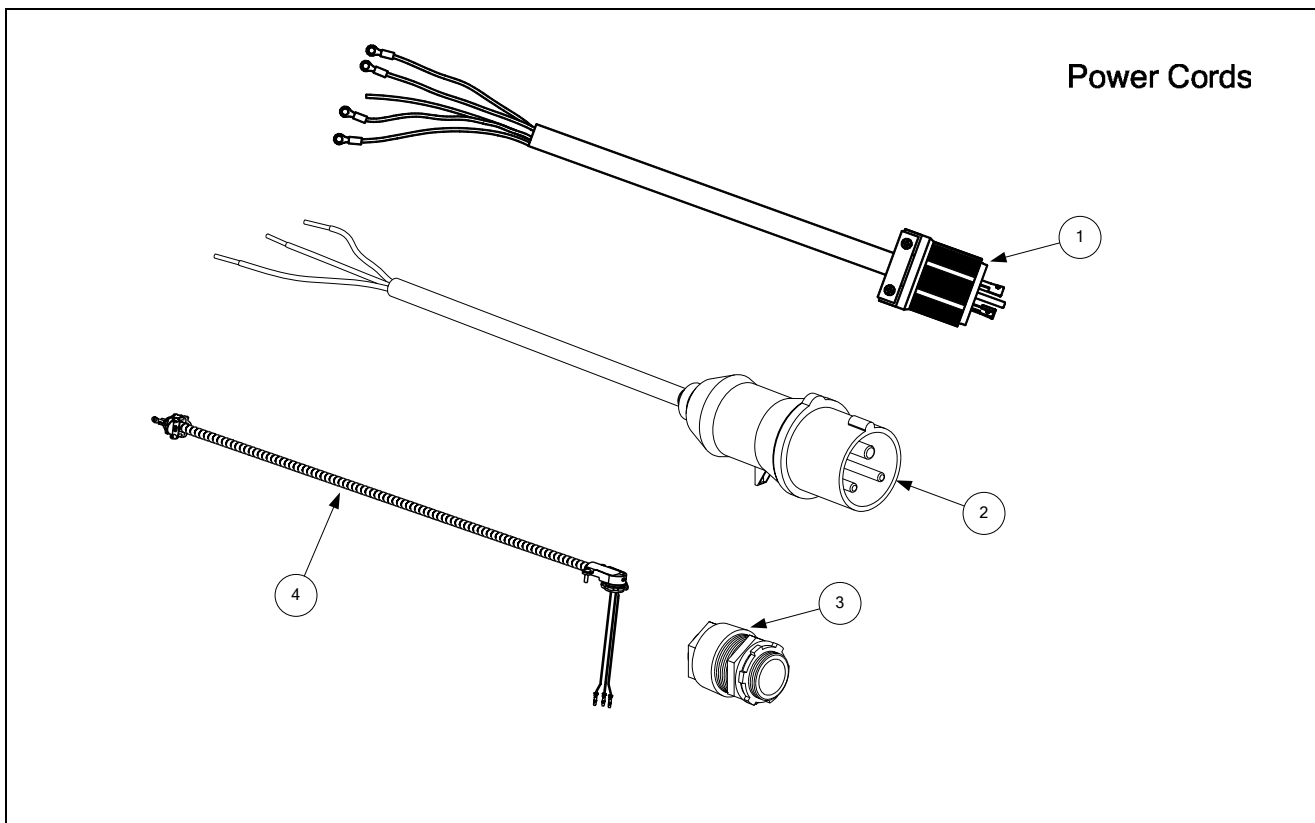

ITEM	PART #	COMPONENT
1	806-6083	Power Cord, 120V w/Grounding Plug 5 wire (w/Ring Terminals, no Clamp)
2	807-1696	Power Cord, CE
3	807-1560	Strain Relief
4	106-1020	Pump Motor to Transfer Box Wiring Assembly

Transformer Box Cable Assemblies

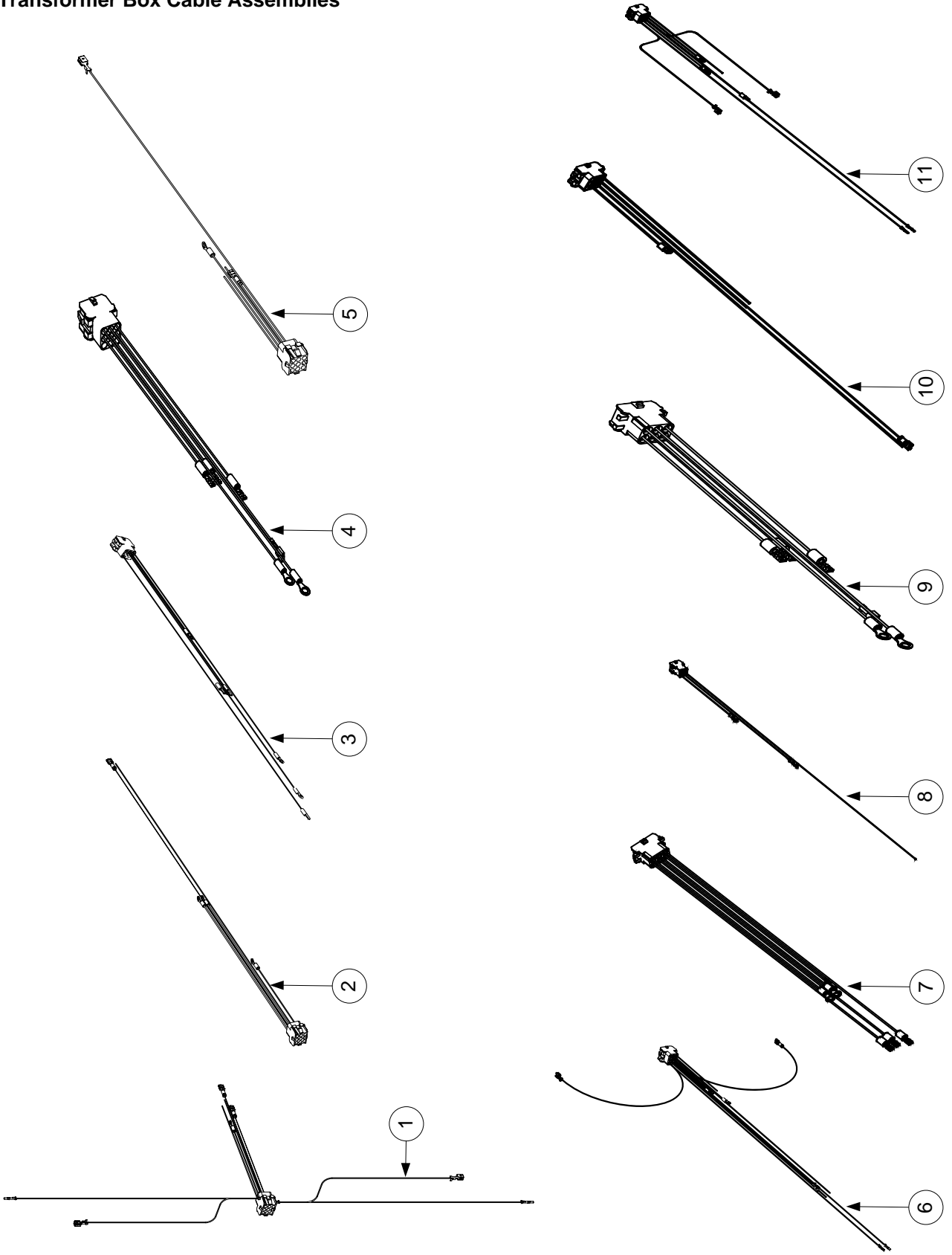

ITEM	PART #	COMPONENT
1	106-1011	Cable Assembly, Transformer Box Line (See NOTE 1)
2	106-1016	Cable Assembly, Transformer Box to Filter Pump (See NOTE 2)
3	106-3821	Cable Assembly, Transformer Box #2 Position (See NOTE 7)
4	106-3820	Cable Assembly, Transformer Box #1 Position (See NOTE 3)
5	106-3316	Cable Assembly, Transformer Box Line (See NOTE 4)
6	106-4990	Cable Assembly, Transformer Box Line (See NOTE 8)
7	106-3825	Cable Assembly, Transformer Box #3 Position (See NOTE 5)
8	106-3826	Cable Assembly, Transformer Box to Filter Pump (See NOTE 5)
9	106-3827	Cable Assembly, Transformer Box #1 Position (See NOTE 5)
10	106-4894	Cable Assembly, Transformer Box to Filter Pump (See NOTE 6)
11	106-4893	Cable Assembly, Transformer Box Line (See NOTE 6)

NOTE 1: Item 1 is used in transformer boxes B and D on page 2-19.

NOTE 2: Item 2 is used in transformer boxes A, B and D on page 2-19.

NOTE 3: Item 4 is used in transformer boxes A, B, D and E on page 2-19.

NOTE 4: Item 5 is used in transformer boxes C and F on pages 2-19 and 2-20.

NOTE 5: Items 7, 8 and 9 are used in transformer boxes C, F and G on pages 2-19 and 2-20.

NOTE 6: Items 10 and 11 are used in transformer box E on page 2-19.

NOTE 7: Item 3 is used in transformer boxes A-F on pages 2-19 and 2-20.

NOTE 8: Item 6 is used in transformer box G on page 2-20.

2.11 Miscellaneous Connectors and Terminals

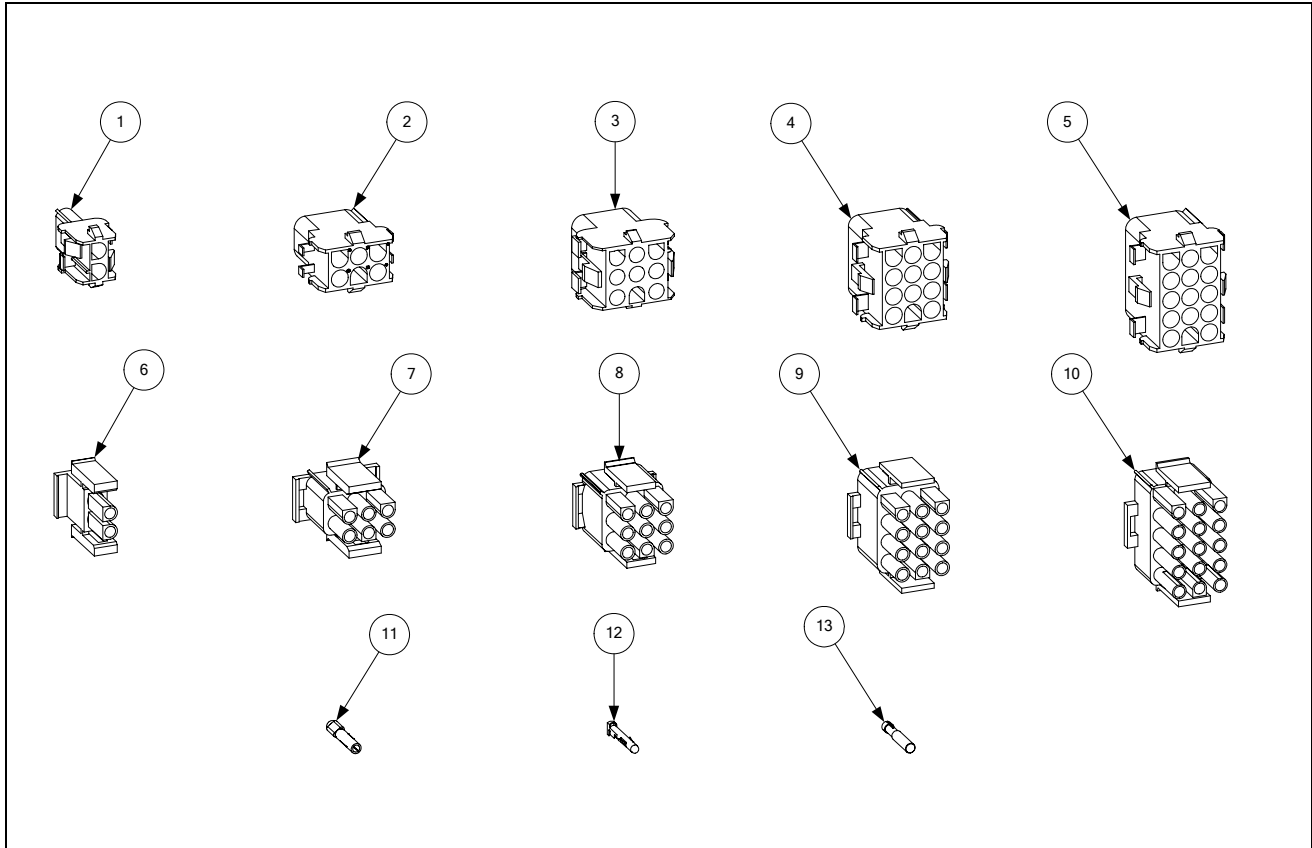

ITEM	PART #	COMPONENT
1	807-1068	2-Pin Female
2	807-0158	6-Pin Female
3	807-0156	9-Pin Female
4	807-0159	12-Pin Female
5	807-0875	15-Pin Female
6	807-1067	2-Pin Male
7	807-0157	6-Pin Male
8	807-0155	9-Pin Male
9	807-0160	12-Pin Male
10	807-0804	15-Pin Male
11	826-1341	Terminal, Female Split Pin (Pkg of 25)
12	826-1342	Terminal, Male Split Pin (Pkg of 25)
13	807-2518	Plug, Mate-N-Lock (Dummy Pin)

* Not illustrated.