

**NAVY SUBMARINE
ELECTRIC FRYER**
Installation, Operation, Service, and Parts Manual

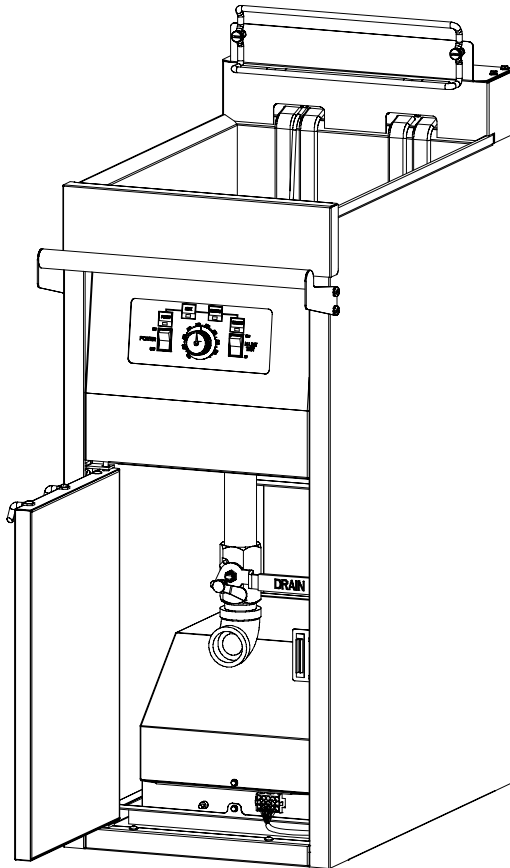

Frymaster, a member of the Commercial Food Equipment Service Association, recommends using CFESA Certified Technicians.

24-Hour Service Hotline 1-800-551-8633

www.frymaster.com

E-mail: service@frymaster.com

OCTOBER 11
* 8196030A *

NOTICE

IF, DURING THE WARRANTY PERIOD, THE CUSTOMER USES A PART FOR THIS MANITOWOC FOOD SERVICE EQUIPMENT OTHER THAN AN **UNMODIFIED** NEW OR RECYCLED PART PURCHASED DIRECTLY FROM FRYMASTER/DEAN, OR ANY OF ITS AUTHORIZED SERVICERS, AND/OR THE PART BEING USED IS MODIFIED FROM ITS ORIGINAL CONFIGURATION, THIS WARRANTY WILL BE VOID. FURTHER, FRYMASTER/DEAN AND ITS AFFILIATES WILL NOT BE LIABLE FOR ANY CLAIMS, DAMAGES OR EXPENSES INCURRED BY THE CUSTOMER WHICH ARISE DIRECTLY OR INDIRECTLY, IN WHOLE OR IN PART, DUE TO THE INSTALLATION OF ANY MODIFIED PART AND/OR PART RECEIVED FROM AN UNAUTHORIZED SERVICER.

⚠ DANGER

Copper wire suitable for at least 167°F (75°C) must be used for power connections.

⚠ DANGER

The electrical power supply for this appliance must be the same as indicated on the rating and serial number plate located on the inside of the fryer door.

⚠ DANGER

This appliance must be connected to the voltage and phase as specified on the rating and serial number plate located on the inside of the fryer door.

⚠ DANGER

All wiring connections for this appliance must be made in accordance with the wiring diagrams furnished with the equipment. Wiring diagrams are located on the inside of the fryer door.

⚠ DANGER

Do not store or use gasoline or other flammable vapors and liquids in the vicinity of this or any other appliance.

⚠ WARNING

Do not use water jets to clean this equipment.



Navy Submarine Electric Fryers Installation, Operation, Service, and Parts Manual

TABLE OF CONTENTS

	Page
Chapter 1: Introduction.....	1-1
Chapter 2: Installation Instructions.....	2-1
Chapter 3: Operating Instructions.....	3-1
Chapter 4: Filtration Instructions.....	4-1
Chapter 5: Preventive Maintenance.....	5-1
Chapter 6: Operator Troubleshooting.....	6-1
Chapter 7: Service Procedures.....	7-1
Chapter 8: Parts List.....	8-1

NAVY SUBMARINE ELECTRIC FRYER

CHAPTER 1: INTRODUCTION

1.1 General

Read the instructions in this manual thoroughly before attempting to operate this equipment. This manual covers the Frymaster Navy Submarine Electric Fryer, a 440V 14kW 3-phase fryer that has been specifically configured for use aboard submarines of the U.S. Navy.

1.2 Safety Information

Before attempting to operate your unit, read the instructions in this manual thoroughly.

Throughout this manual, you will find notations enclosed in double-bordered boxes similar to the one below.

 DANGER
Hot cooking oil causes severe burns. Never attempt to move a fryer containing hot cooking oil/shortening or to transfer hot cooking oil/shortening from one container to another.

 **CAUTION** boxes contain information about actions or conditions that *may cause or result in a malfunction of your system*.

 **WARNING** boxes contain information about actions or conditions that *may cause or result in damage to your system*, and which may cause your system to malfunction.

 **DANGER** boxes contain information about actions or conditions that *may cause or result in injury to personnel*, and which may cause damage to your system and/or cause your system to malfunction.

Fryers in this series are equipped with two high-temperature detection features that shut off power to the unit by means of an external shunt trip disconnect should the temperature controls fail.

1.3 Controller Information

This equipment has been tested and found to comply with the limits for a Class A digital device, pursuant to Part 15 of the FCC rules. While this device is a verified Class A device, it has been shown to meet the Class B limits. These limits are designed to provide reasonable protection against harmful interference when the equipment is operated in a shipboard environment. This equipment generates, uses, and can radiate radio frequency energy and, if not installed and used in accordance with the instruction manual, may cause harmful interference to radio communications and other electronic devices.

1.4 Shipping Damage Claim Procedure

What to do if this equipment arrives damaged:

Please note that this equipment was carefully inspected and packed by skilled personnel before leaving the factory. The freight company assumes full responsibility for safe delivery upon acceptance of the equipment.

1. File Claim for Damages Immediately—Regardless of extent of damage.
2. Visible Loss or Damage—Be sure this is noted on the freight bill or express receipt and is signed by the person making the delivery.
3. Concealed Loss or Damage—If damage is unnoticed until equipment is unpacked, notify the freight company or carrier immediately and file a concealed damage claim. This should be done within 15 days of date of delivery. Be sure to retain container for inspection.

1.5 Service Information

For non-routine maintenance or repairs, or for service information, contact your local Frymaster Authorized Servicer (FAS). A list of Frymaster Factory Authorized Servicers (FAS's) is located on the Frymaster website at www.frymaster.com. Service information may also be obtained by calling the Frymaster Technical Services Department (1-800-551-8633). The following information will be needed in order to assist you efficiently:

Model Number: _____
Serial Number: _____
Voltage: _____

Also be prepared to describe the specific problem.

RETAIN AND STORE THIS MANUAL IN A SAFE PLACE FOR FUTURE USE.

NAVY SUBMARINE ELECTRIC FRYER

CHAPTER 2: INSTALLATION INSTRUCTIONS

2.1 General

Proper installation is essential for the safe, efficient, trouble-free operation of this appliance. Any unauthorized alteration of this equipment will void the Frymaster warranty.

NOTICE

If this equipment is wired directly into the electrical power supply, a means for disconnection from the supply having a contact separation of at least 3-mm in all poles must be incorporated in the fixed wiring.

NOTICE

This equipment must be positioned so that the plug is accessible unless other means for disconnection from the power supply (e.g., a circuit breaker) is provided.

NOTICE

If this appliance is permanently connected to fixed wiring, it must be connected by means of copper wires having a temperature rating of not less than 167°F (75°C).

NOTICE

If the electrical power supply cord is damaged, it must be replaced by a Frymaster/Dean Factory Authorized Servicer technician or a similarly qualified person in order to avoid a hazard.

DANGER

This appliance must be connected to a power supply having the same voltage and phase as specified on the rating plate located on the inside of the appliance door.

DANGER

All wiring connections for this appliance must be made in accordance with the wiring diagram(s) furnished with the appliance. Refer to the wiring diagram affixed to the inside of the appliance door when installing or servicing this equipment.

DANGER

The appliance area must be kept free and clear of combustible material at all times.

All installation and service on FRYMASTER equipment must be performed by qualified, certified, licensed, and/or authorized installation or service personnel.

Service may be obtained by contacting a local Frymaster/DEAN Factory Authorized Servicer.

In the event of a power failure, the fryer will automatically shut down. If this occurs, turn the power switch OFF. Do not attempt to start the fryer until power is restored.

A clearance of 6 inches (15cm) must be provided at both sides and back adjacent to combustible construction. A minimum of 24 inches (61cm) should be provided at the front of the equipment for servicing and proper operation.

Connections should be made by means of an approved, flexible-metallic or rubber-covered electrical cable and quick-disconnect plug. The fryers may be installed with “hard-wired” connections, but use of quick-disconnect plugs will facilitate service if required. Connections are made to the fryer power input terminal block located in the contactor box in the bottom of the fryer.

⚠ DANGER

Observe the following precautions when connecting the fryer to an emergency cutoff system:

- **Be sure that each fryer is connected to a dedicated set of contacts in the emergency cutoff system.**
- **Do not connect the contacts in series.**
- **Do not connect more than one fryer to each set of contacts.**
- **The contacts MUST be normally closed contacts that open in an emergency.**
- **The contacts CANNOT have an external voltage applied.**

2.2 Power Requirements

MODEL	VOLTAGE	PHASE	WIRE SERVICE	MIN. SIZE	AWG (mm ²)	AMPS PER LEG		
						L1	L2	L3
H14 (Submarine)	440	3	3	8	(10)	19	19	19

NOTICE

If this appliance is permanently connected to fixed wiring, it must be connected by means of copper wires having a temperature rating of not less than 167°F (75°C).

⚠ DANGER

This appliance must be connected to a power supply having the same voltage and phase as specified on the rating plate located on the inside of the appliance door.

⚠ DANGER

All wiring connections for this appliance must be made in accordance with the wiring diagram furnished with the appliance. Refer to the wiring diagram affixed to the inside of the appliance door when installing or servicing this equipment.

2.3 Installation

1. This equipment must be securely bolted to the deck.
2. Install deck studs for the specific fryer configuration in accordance with the diagram below.

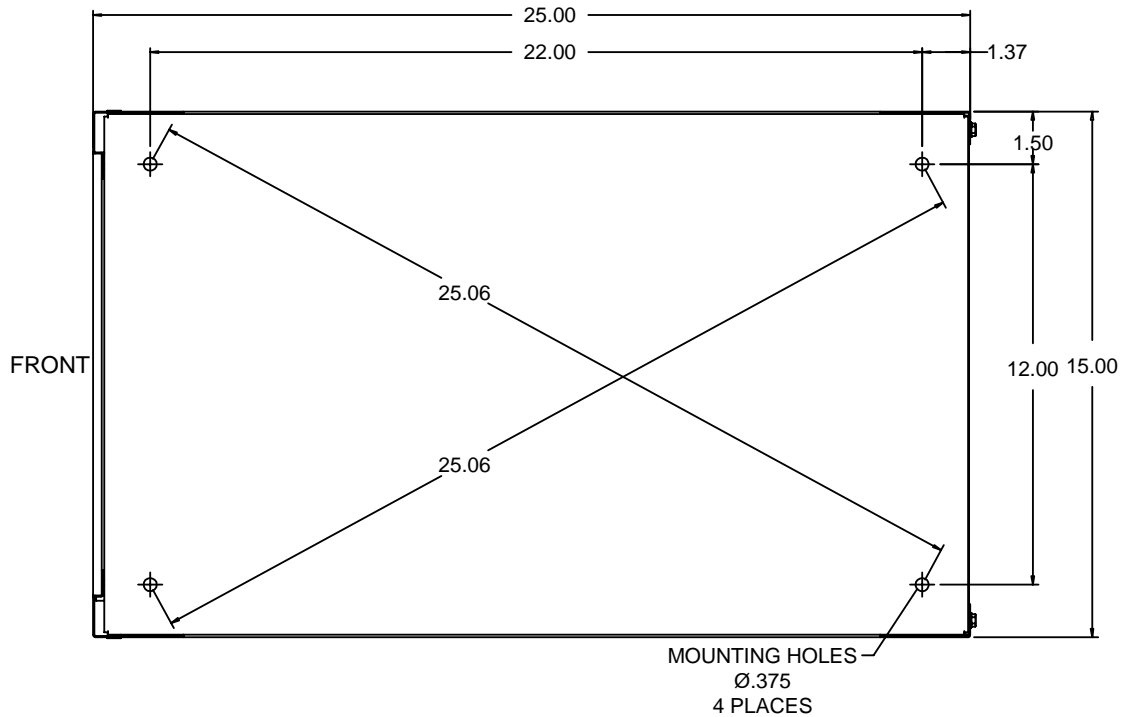

3. Position the fryer on the deck studs and secure with appropriate nuts and lock washers.

⚠ DANGER

No structural material on the fryer should be altered or removed to accommodate placement of the fryer under a hood. Questions? Call the Frymaster/Dean Service Hotline at 1-800-551-8633.

2.4 After Fryer is Anchored at the Frying Station

⚠ DANGER

Hot shortening can cause severe burns. Avoid contact. Under all circumstances, oil must be removed from the fryer before attempting to move it to avoid oil spills, falls and severe burns. This fryer may tip and cause personal injury if not secured in a stationary position.

1. Close the frypot drain-valve and fill the frypot with water to the bottom oil level line.
2. Boil out the frypot in accordance with the instructions in Section 5.1.3 of this manual.
3. Drain, clean, and fill the frypot with cooking oil. (See *Equipment Setup and Shutdown Procedures* in Chapter 3.)

NAVY SUBMARINE ELECTRIC FRYER

CHAPTER 3: OPERATING INSTRUCTIONS

3.1 Equipment Setup and Shutdown Procedures

Setup

⚠ DANGER

Never operate the appliance with an empty frypot. The frypot must be filled with water or cooking oil/shortening before energizing the elements. Failure to do so will result in irreparable damage to the elements and may cause a fire.

⚠ DANGER

Remove all drops of water from the frypot before filling with cooking oil or shortening. Failure to do so will cause spattering of hot liquid when the oil or shortening is heated to cooking temperature.

1. Fill the frypot with cooking oil to the bottom OIL LEVEL line located on the rear of the frypot. This will allow for oil expansion as heat is applied. Do not fill cold oil any higher than the bottom line; overflow may occur as heat expands the oil.

NOTE: If solid shortening is used, it should be pre-melted outside the frypot then transferred to the frypot. If the solid shortening is not pre-melted, it must be packed down between the elements into the bottom of the frypot.

⚠ DANGER

Never set a complete block of solid shortening on top of the heating elements.

When using solid shortening, always pre-melt the shortening before adding it to the frypot. If the shortening is not pre-melted, it must be packed down into the bottom of the frypot and between the elements, and the fryer must be started in the melt-cycle mode.

Never cancel the melt-cycle mode when using solid shortening. Doing so will result in damage to the elements and increase the potential for a flash fire.

2. If the fryer is not hard-wired into the power supply, ensure that the power cord is plugged into the appropriate receptacle. Verify that the face of the plug is flush with the outlet plate, with no portion of the prongs visible.
3. Ensure that the oil/shortening level is at the *top* OIL LEVEL line when the oil/shortening *is at its cooking temperature*. It may be necessary to add oil/shortening to bring the level up to the proper mark, *after it has reached cooking temperature*.

Shutdown

1. Turn the fryer off.
2. Filter the cooking oil/shortening and clean the fryers (See Chapters 4 and 5).
3. Place the frypot covers on the frypots.

3.2 Operation of the Solid-State Analog Controller

Fryers configured for the U.S. Navy are equipped with solid-state analog controllers, illustrated below.

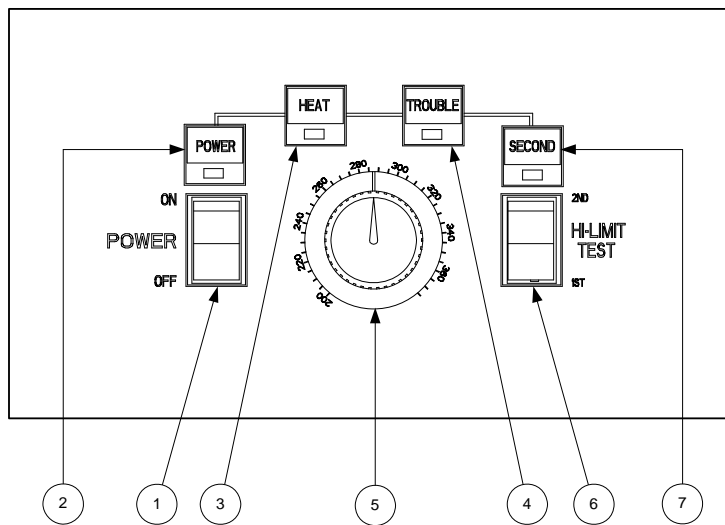

U.S. Navy Solid-State Analog Controller

ITEM	DESCRIPTION
1	Power Switch – Controls electrical power to fryer.
2	Power-On Light – Indicates when electrical power to fryer is ON.
3	Heating Mode Light – Indicates when heating element is ON.
4	Trouble Light – Indicates over high-limit or problem in heat control circuitry.
5	Thermostat Control Knob – Sets desired frying temperature.
6	Hi-Limit Test Switch – Tests high-limit thermostat.
7	Second Hi-Limit Test Light – Indicates fryer is in second high-limit test mode.

The analog controller is used to adjust and maintain oil at the temperature indicated by the thermostat knob.

The fryer has two built-in high-limit protection features. If the temperature in the frypot reaches approximately 410°F, the controller opens the heat relay circuit, turning the elements off. If the temperature in the frypot reaches 450°F, a mechanical high-limit shuts off electrical power to the fryer *The operator should periodically test each of the high-limit protection features, using the procedure at the end of this chapter, to verify that they are operating correctly.*

The analog controller has no timing features. The operator must monitor shake and pull times.

CONTROLLER OPERATING PROCEDURE

1. Verify that the thermostat knob is set to the desired cooking temperature.
2. Press the power switch to the ON position. The POWER light will illuminate.

WARNING

Before pressing the power switch to the ON position, ensure that the frypot is properly filled with oil. See Section 3.1.

3. If the frypot temperature is below 180°F, the controller will automatically enter a warm-up cycle (often called a melt cycle). The heating elements will cycle on and off repeatedly, allowing the oil to heat gradually, without scorching. During the warm-up cycle, the heating mode light will alternately illuminate and go off as the elements cycle on and off. Within about 45 minutes, the controller will exit the warm-up cycle and the heating mode light will remain continuously illuminated.
4. When the oil temperature reaches the thermostat knob setpoint, the elements will cycle OFF and the HEAT light will go off, indicating that the fryer is ready for the cooking process to begin.

HI-LIMIT TEST PROCEDURE

Tools Required: One 0-600°F pyrometer with sensing probe or an equivalent high-temperature thermometer.

NOTE: Conduct this test when the fryer will not be needed for about one hour and when the cooking oil is due to be changed (the test will ruin the cooking oil). Start the test with the controller turned ON and with the cooking oil at normal frying temperature. Stir the oil thoroughly to ensure even distribution and temperature.

DANGER

If the expected results (indicated by italics) for Steps 3 and 4 below do not occur, turn off the fryer at the main circuit breaker panel and do not use the fryer until it has been repaired by an authorized technician.

1. Verify that cooking oil is at the bottom OIL-LEVEL line. Add oil if necessary.
2. Turn the power switch ON and set the control knob to the normal frying temperature.
3. Insert the pyrometer probe into the frypot so that its tip is near the temperature probe on the element (i.e., approximately 1½-inch into the oil, near the center of the frypot). Press and hold the high limit test switch in the “1ST” test position until the TROUBLE light illuminates. Release the test switch.

The trouble light should have come on when the temperature was approximately 410°F (± 3°F) and the heating elements should have de-energized (indicated by the HEAT light going out).

4. Press and hold the high limit test switch in the “2ND” test position until the SECOND light illuminates. Release the switch.

The light should have come on when the temperature was between 430°F and 460°F.

*For fryers connected to an external shunt power supply, **all** fryers should have been shut off completely and all control panel lights should have been extinguished. For fryers not connected to an external shunt power supply, only the fryer being tested should have been shut off.*

5. Place the controller power switch in the OFF position.
6. Allow the cooking oil to cool to below normal frying temperature.

When the power switch is again placed in the ON position, the elements should re-energize and the operating thermostat should resume control of the temperature. If the TROUBLE light remains on instead, allow the oil additional time to cool.

NAVY SUBMARINE ELECTRIC FRYER

CHAPTER 4: DRAINING AND FILTERING INSTRUCTIONS

4.1 Introduction

Submarine fryers are not equipped with built-in filtration. They must be manually drained and filtered.

4.2 Draining and Disposing of Waste Oil

Turn the fryer off and allow the oil/shortening to cool to 100°F. Screw the drain extension furnished with the fryer into the drain valve, then open the valve and drain the oil/shortening into the drain pan furnished with the fryer for transport to a disposal container. When draining is finished, close the fryer drain valve securely.

 **DANGER**

Make sure the fryer is off before draining. Allow the oil/shortening to cool to 100°F before draining into an appropriate container for disposal.

4.3 Filtering

To prolong the life of your cooking oil or shortening and to ensure high quality fried foods, the oil or shortening should be filtered on a routine basis.

The frequency of filtering depends upon how often the oil is used, how much food is fried, and the type of food fried. As a minimum, the oil should be filtered each time the frypot is emptied. However, the more you fry, the more you will need to filter. Frying produces sediment. Sediment accumulation has two effects. First, it reduces the efficiency of the fryer. Second, it has a tendency to scorch, which results in bad tasting food. Food that produces a large amount of sediment, such as breaded fish products, require that the oil be filtered more often than foods such as french-fries, which produce comparatively little sediment.

To aid in the filtering process, a filter cone holder and paper filter cones may be ordered from Frymaster FASs or kitchen equipment suppliers. To order the cone holder, use P/N 803-0072. To order a box of 50 filters, use P/N 803-0042. To order a case containing 500 filters, use P/N 803-0075.

NAVY SUBMARINE ELECTRIC FRYER

CHAPTER 5: PREVENTIVE MAINTENANCE

5.1 Cleaning the Fryer

⚠ DANGER

Never attempt to clean the fryer during the frying process or when the frypot is filled with hot oil/shortening. If water comes in contact with oil/shortening heated to frying temperature, it will cause spattering of the oil/shortening, which can result in severe burns to nearby personnel.

⚠ WARNING

Use a commercial-grade cleaner formulated to effectively clean and sanitize food-contact surfaces. Read the directions for use and precautionary statements before use. Particular attention must be paid to the concentration of cleaner and the length of time the cleaner remains on the food-contact surfaces.

5.1.1 Clean Inside and Outside of the Fryer Cabinet – Daily

Clean inside the fryer cabinet with a dry, clean cloth. Wipe all accessible metal surfaces and components to remove accumulated oil/shortening and dust.

Clean outside the fryer cabinet, with a clean, damp cloth soaked with dishwashing detergent. Wipe with a clean, damp cloth.

5.1.2 Clean the Frypot and Heating Elements – Weekly

⚠ DANGER

Never operate the appliance with an empty frypot. The frypot must be filled with water or cooking oil/shortening before energizing the elements. Failure to do so will result in irreparable damage to the elements and may cause a fire.

Boiling-Out the Frypot

Before the fryer is first used, it should be boiled out to ensure that residue from the manufacturing process has been eliminated. Also, after the fryer has been in use for a period of time, a hard film of caramelized vegetable oil will form on the inside of the frypot. This film should be periodically removed by following the boil-out procedure that follows.

1. Before switching the fryer ON, close the frypot drain valve, then fill the empty frypot with a mixture of cold water and dishwashing detergent. Follow instructions on detergent container when mixing.
2. Press the fryer ON/OFF switch to the ON position.
3. Set the temperature control knob to the lowest setting.

4. Simmer the solution for 45 minutes to one hour. Do not allow the water level to drop below the bottom oil-level line in the frypot during the boil-out operation.

⚠ DANGER

Never leave the fryer unattended during the boil-out process. If the boil-out solution boils over, turn the fryer off immediately and let the solution cool for a few minutes before resuming the process.

5. Turn the fryer ON/OFF switch to the OFF position.
6. Add two gallons of water. Drain out the solution and clean the frypot(s) thoroughly.
7. Refill the frypot with clean water. Rinse the frypot twice, drain and dry with a clean towel. Thoroughly remove all water from the frypot and elements before refilling the frypot with cooking oil/shortening.

⚠ DANGER

Remove all drops of water from the frypot before filling with cooking oil or shortening. Failure to do so will cause spattering of hot liquid when the oil or shortening is heated to cooking temperature.

5.1.3 Clean Detachable Parts and Accessories – Weekly

Wipe all detachable parts and accessories with a clean, dry cloth. Use a clean cloth saturated with detergent to remove accumulated carbonized oil/shortening on detachable parts and accessories. Rinse the parts and accessories thoroughly with clean water and wipe dry before reinstalling.

5.2 Check Calibration of Temperature Control Knob – Monthly

1. After the cooking oil/shortening reaches operating temperature, let the heating elements cycle at least four times (indicated by the HEAT light going out and coming back on).
2. Insert a thermometer or pyrometer probe near the temperature-sensing probe approximately three inches deep into the cooking oil/shortening. When the heating elements cycle on for the fourth time, the thermometer should read within $\pm 5^{\circ}\text{F}$ of the temperature control knob setting.
3. If the knob requires adjustment:
 - a. Loosen the setscrew in the control knob until the outer shell of the knob will rotate on the insert inside the knob.
 - b. Rotate the outer shell of the knob until the index line on the knob aligns with the mark that corresponds to the thermometer or pyrometer reading.
 - c. Hold the knob and tighten the setscrew.
 - d. Recheck the thermometer or pyrometer reading and the temperature control knob setting the next time the HEAT light illuminates.

- e. Repeat steps a through d until the thermometer or pyrometer reading and the knob setting agree within 5°F.

5.3 Annual/Periodic System Inspection

This appliance should be inspected and adjusted periodically by qualified service personnel as part of the galley material maintenance management (3M) program.

Frymaster recommends that a Factory Authorized Servicer inspect this appliance at least annually as follows:

Fryer

- Inspect the cabinet inside and out, front and rear for excessive oil build-up and/or oil migration.
- Verify that the heating element wires are in good condition and that leads have no visible fraying or insulation damage and that they are free of oil migration build-up.
- Verify that heating elements are in good condition with no carbon/caramelized oil build-up. Inspect the elements for signs of extensive dry-firing.
- Verify the heating-element amp-draw is within the allowed range as indicated on the appliance's rating plate.
- Verify that the temperature and high-limit probes are properly connected, tightened and functioning properly, and that mounting hardware and probe guards are present and properly installed.
- Verify that component box and contactor box components (i.e. controller, relays, interface boards, transformers, contactors, etc.) are in good condition and free from oil migration build-up and other debris.
- Verify that component box and contactor box wiring connections are tight and that wiring is in good condition.
- Verify that all safety features (i.e. contactor shields, shunts, reset switches, etc.) are present and functioning properly.
- Verify that the frypot is in good condition and free of leaks and that the frypot insulation is in serviceable condition.
- Verify that all wiring harnesses and wiring connections are tight and in good condition.

NAVY SUBMARINE ELECTRIC FRYER

CHAPTER 6: OPERATOR TROUBLESHOOTING

6.1 Introduction

This section provides an easy reference guide to some of the common problems that may occur during the operation of this equipment. The troubleshooting guides that follow are intended to help correct, or at least accurately diagnose, problems with this equipment. Although the chapter covers the most common problems reported, you may encounter problems that are not covered. In such instances, the Frymaster Technical Services staff will make every effort to help you identify and resolve the problem.

When troubleshooting a problem, always use a process of elimination starting with the simplest solution and working through to the most complex. Most importantly, always try to establish a clear idea of why a problem has occurred. Part of any corrective action involves taking steps to ensure that it doesn't happen again. If a controller malfunctions because of a poor connection, check all other connections, too. If a circuit breaker continues to trip, find out why. Always keep in mind that failure of a small component may often be indicative of potential failure or incorrect functioning of a more important component or system.

Before calling a service agent or the Frymaster HOTLINE (1-800-551-8633):

- **Verify that electrical cord is plugged in and that circuit breakers are on.**
- **Verify that shunt has not been tripped.**

 DANGER

Hot cooking oil/shortening will cause severe burns. Never attempt to transfer hot cooking oil/shortening from one container to another.

 DANGER

This equipment should be disconnected from the electrical power supply when servicing, except when electrical circuit tests are required. Use extreme care when performing such tests.

This appliance may have more than one electrical power supply connection point.

Inspection, testing, and repair of electrical components should be performed by authorized personnel only.

6.2 Troubleshooting

6.2.1 Control and Heating Problems

Problem	Probable Causes	Corrective Action
<p>Controller won't activate.</p>	<p>A. Power cord is not plugged in or circuit breaker is tripped.</p>	<p>A. Plug power cord in and verify that circuit breaker is not tripped.</p>
	<p>B. Controller has failed.</p>	<p>B. If available, substitute a controller known to be working for the suspect controller. If the substitute controller functions correctly, order a new controller.</p>
	<p>C. Power supply component or interface board has failed.</p>	<p>C. If any of the components in the power supply system (including the transformer and interface board) fail, power will not be supplied to the controller and it will not function. Determining which component has failed is beyond the scope of operator troubleshooting.</p>
<p>Fryer does not heat.</p>	<p>A. Controller has failed.</p>	<p>A. If available, substitute a controller known to be working for the suspect controller. If the substitute controller functions correctly, order a new controller.</p>
	<p>B. One or more other components have failed.</p>	<p>B. If the circuitry in the fryer control system cannot determine the frypot temperature, the system will not allow the element to be energized or will de-energize the element if it is already energized. If the contactor, element, or associated wiring fails, the element will not energize. Determining which specific component is malfunctioning is beyond the scope of operator troubleshooting.</p>

Problem	Probable Causes	Corrective Action
<p>Fryer repeatedly cycles on and off when first started.</p>	<p>Fryer is in melt-cycle mode.</p>	<p>This is normal. The standard operational mode for the controller is for the elements to cycle on and off until the temperature in the frypot reaches 180°F. The purpose of the melt-cycle is to allow controlled melting of solid shortening to prevent scorching and flash fires or damage to the element.</p>
<p>Fryer heats until high limit trips with heat indicator ON.</p>	<p>Temperature probe or controller has failed.</p>	<p>If available, substitute a controller known to be working for the suspect controller. If the substitute controller functions correctly, order a new controller. If substitution of the controller does not resolve the problem, the most likely cause is a failed temperature probe.</p>
<p>Fryer heats until high limit trips without heat indicator ON.</p>	<p>Contact or controller has failed.</p>	<p>If available, substitute a controller known to be working for the suspect controller. If the substitute controller functions correctly, order a new controller. If substitution of the controller does not resolve the problem, the most likely cause is a contactor failed in the closed position.</p>
<p>Fryer stops heating with heat indicator ON.</p>	<p>The high limit thermostat or contactor has failed.</p>	<p>The fact that the heat indicator is ON indicates that the controller is functioning properly and is calling for heat. The high limit thermostat functions as a normally closed switch. If the thermostat fails, the "switch" opens and power to the elements is shut off. If the contactor fails to close, no power is supplied to the elements. Determining which component has failed is beyond the scope of operator troubleshooting.</p>

6.2.2 Error Messages and Display Problems

Problem	Probable Causes	Corrective Action
Controller trouble light ON.	Oil temperature above acceptable range or a problem with the temperature measuring circuitry.	This is an indication of a malfunction in the temperature measuring or control circuitry, including a failure of the high limit thermostat. Determining the specific problem is beyond the scope of operator troubleshooting. Shut the fryer down immediately.
Controller trouble light ON and heating mode light ON.	Problem with latching circuitry.	The problem is within the latching circuitry and is beyond the scope of operator troubleshooting. Shut the fryer down immediately.

6.3 Replacing the Controller or Controller Cable

1. Disconnect the fryer from the electrical supply, remove the two screws in the upper corners of the control panel assembly and swing the assembly open from the top.

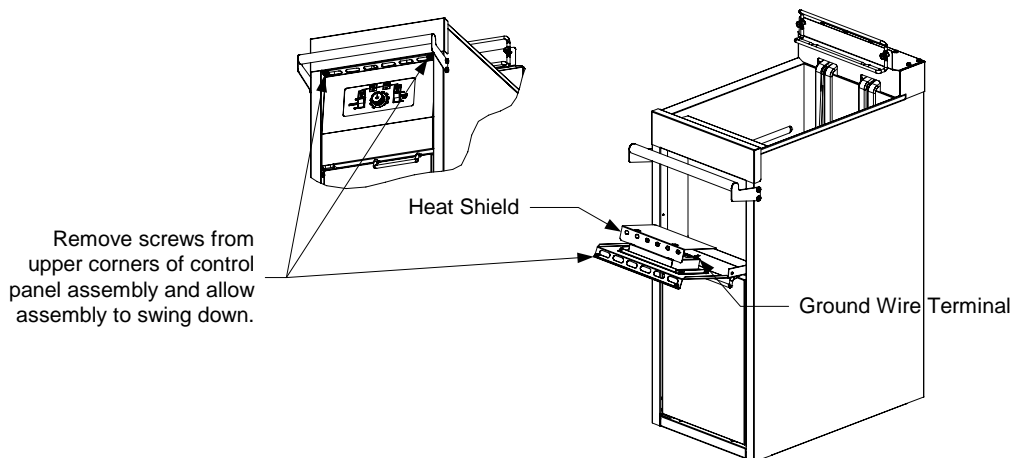

2. Remove the two screws that secure the assembly into the cabinet and pull the assembly out of the fryer.
3. Disconnect the controller cable from the back of the controller.
4. **If replacing the controller cable**, disconnect it from the front of the contactor box and cut the wire ties that secure it to the wiring bundle. Route the replacement cable, secure it in place with wire ties, and connect it to the controller and the contactor box connections. Reverse steps 1 and 2 to complete the procedure.
5. **If replacing the controller**, disconnect the ground wire from the terminal on the back of the controller, remove the heat shield from the controller, and remove the controller from the bezel. Install the new controller on the bezel, re-install the heat shield, and reconnect the ground wire and controller cable to the controller. Reverse steps 1 and 2 to complete the procedure.

NAVY SUBMARINE ELECTRIC FRYER

CHAPTER 7: SERVICE PROCEDURES

7.1 General

Before performing any maintenance on this equipment, disconnect the fryer from the electrical power supply and drain the frypot.

When electrical wires are disconnected, it is recommended that they be marked in such a way as to facilitate re-assembly.

7.2 Replacing a Controller or Controller Cable

Refer to page 6-4 for the procedure for replacing the controller or controller cable.

7.3 Replacing Contactor Box Components

⚠ DANGER
Before performing any replacement of components in the contactor box, disconnect the fryer from the electrical power supply and drain the frypot.

The contactor box is located in the bottom of the fryer cabinet. In some cases, components may be removed without removing the box from the fryer, but in most cases it is best to remove the entire box from the fryer, or at least pull it partially out of the cabinet, for easier access.

The lid to the contractor box is held in place by a single screw (Figure 1 below). The box is attached to the fryer cabinet by means of a single screw on the front of the box and a pair of tabs on the rear of the box that engage slots in the cabinet frame (Figure 2). The door, door magnet, and drain elbow must also be removed to allow the box to be pulled from the cabinet.

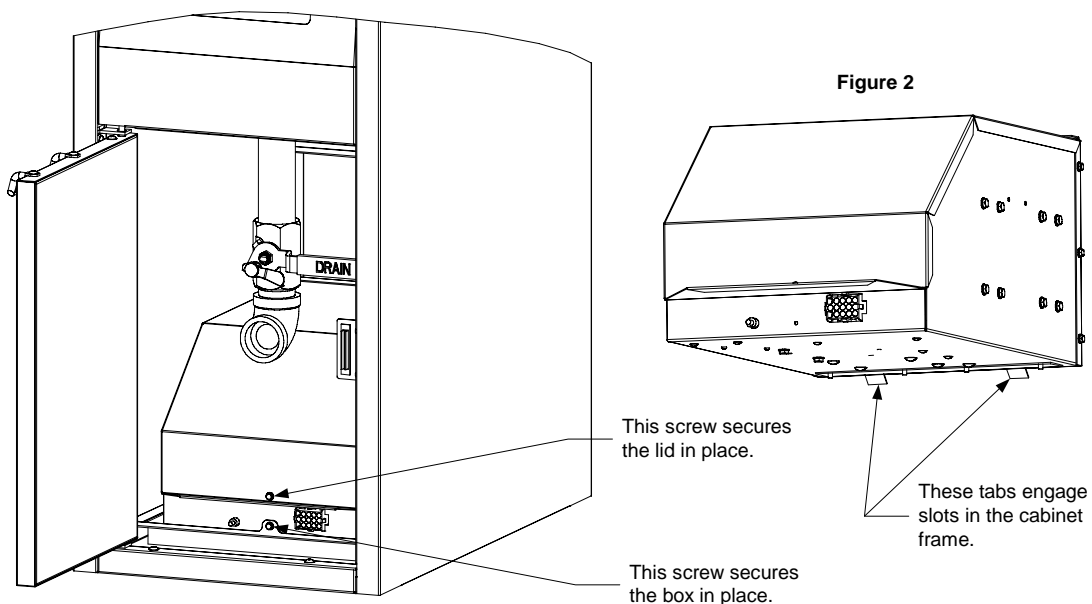

Figure 1

Figure 2

7.3.1 Replacing the Interface Board

1. Remove the contactor box lid and unplug the wiring harnesses from the front and back of the interface board.
2. Remove the nuts in each corner of the interface board and slide the board off its mounting studs.
3. Verify that the spacers are in place on the studs, then position the replacement board on the studs and re-install the nuts removed in step 2.
4. Reconnect the wiring harnesses and replace the lid to complete the procedure.

7.3.2 Replacing Other Contactor Box Components

1. Unplug the control cable from the front of the contactor box. Remove the door magnet and drain elbow. Remove the screw that secures the box in place and pull the box from the cabinet to the extent that the wiring allows. If necessary, disconnect the wiring connectors at the rear of the box to allow the box to be removed completely from the cabinet.
2. Disconnect the wiring from the component, being sure to make a note or sketch of the wiring connections. Dismount the component to be replaced and install the new component, being sure that any required spacers, insulation, washers, etc. are in place.
3. Reconnect the wiring disconnected in step 2, referring to your notes and the wiring diagram on the fryer door to ensure that the connections are properly made. Also, verify that no other wiring was disconnected accidentally during the replacement process.
4. Reposition the contactor box in the cabinet and secure in place with the screw removed in step 1. Reinstall the door magnet, drain elbow, and door to complete the procedure.

7.4 Replacing a Temperature Probe or High-Limit Thermostat

1. Disconnect the fryer from the electrical power supply and drain the frypot into the drain pan provided with the fryer or other appropriate container.
2. Remove the contactor box (see step 1 of section 7.3.2 above). Remove the nuts securing the fryer to the deck and reposition it to gain access to the rear of the fryer.
3. Remove the screws that secure the element housing and back panel to the fryer and remove the element housing and back panel to expose the element assembly and rear of the frypot.
4. Locate connector C7 and disconnect it. Using a pin pusher (Frymaster P/N 8064855), push out the red and white leads if replacing the temperature probe, or the black leads if replacing the high-limit thermostat.
5. *If replacing a temperature probe*, cut the metal wire tie securing the probe to the element, remove the screw securing the probe bracket to the element assembly, and slide the bracket off the probe (see illustration on following page). Pull the probe leads out of the hole in the element assembly and remove the probe from the fryer. Thread the leads of the replacement probe through the hole in the element assembly, position the replacement probe in the element bracket, and reattach the element bracket to the assembly. Secure the upper portion of the probe with a replacement metal wire tie.

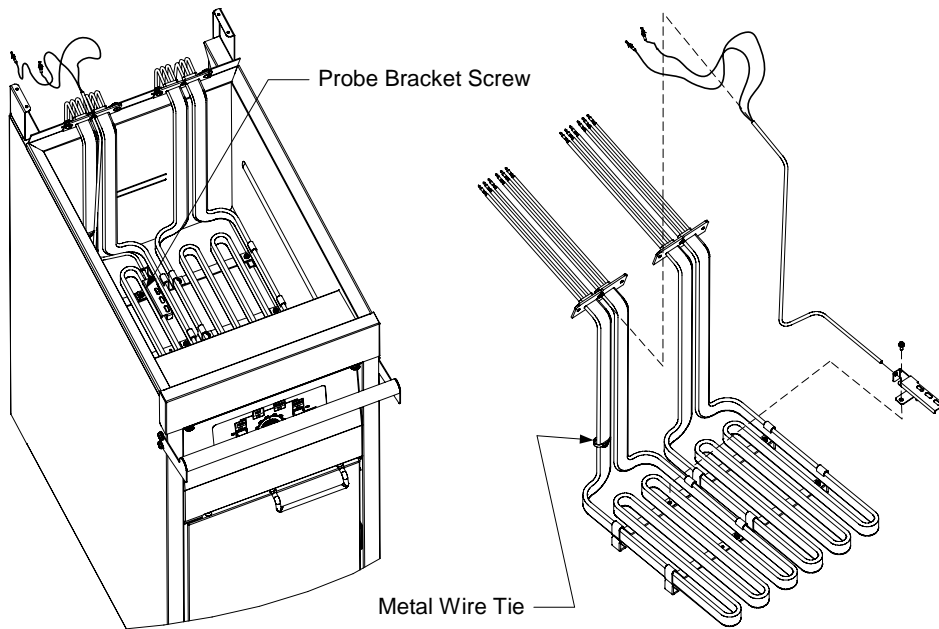

If replacing a high-limit thermostat, unscrew the thermostat. Apply Loctite™ PST 567 or equivalent sealant to the threads of the replacement and screw it securely into the frypot.

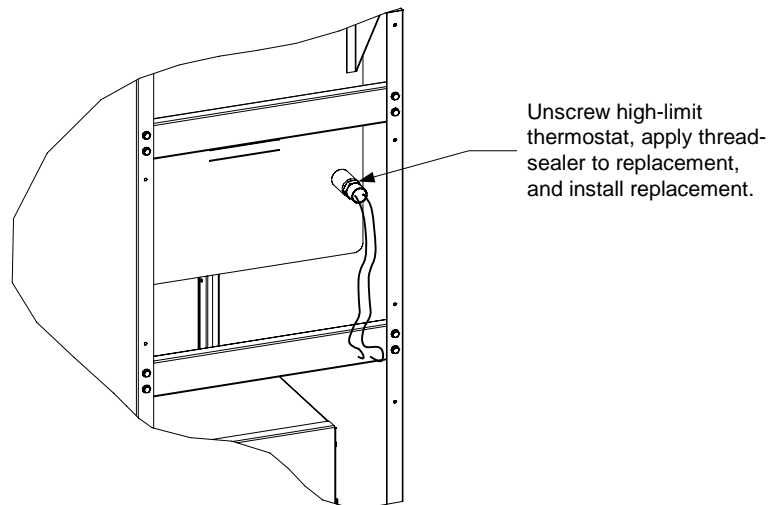

6. ***If a temperature probe was replaced, insert the probe leads into the connector (see left illustration below).*** The white lead goes into position 1 and the red into position 2.

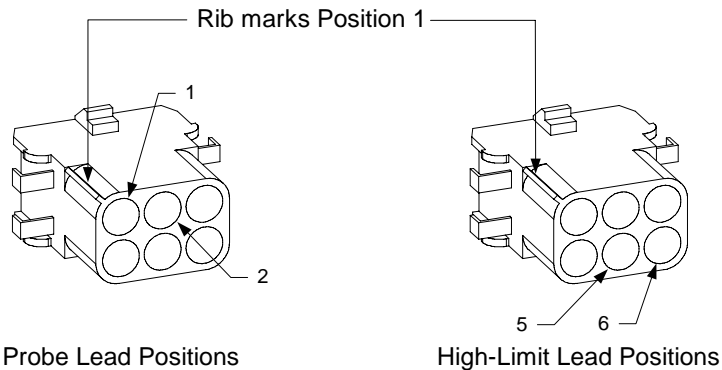

If a high-limit thermostat was replaced, insert the leads into the connector (see right illustration above). The leads go into positions 5 and 6. Polarity does not matter.

7. Reinstall the back panel and element housing to complete the installation, then reverse steps 1 and 2 to return the fryer to service.

7.5 Replacing a Heating Element

1. Perform steps 1-3 of section 7.4, *Replacing a Temperature Probe or High-Limit Thermostat*.
2. Locate and disconnect connector C7. Using a pin pusher (Frymaster P/N 8064855), push out the red and white leads.
3. On the rear of the contactor box, disconnect the 6-pin and 9-pin connectors.
4. Remove the nuts and machine screws that secure the element assembly to the frypot and lift the assembly out of the frypot. Remove the screws from the appropriate element clamps to separate the element being replaced from the assembly.
5. If the element with the probe is being replaced, recover the probe bracket and probe from the element and install them on the replacement element. Install the replacement element in the assembly using the screws and clamps removed in step 4. Reattach the assembly to the frypot using the original mounting screws and nuts.
6. Press in on the tabs on each side of the connector of the failed element while pulling outward on the free end to extend the connector and release the element leads (see photo below). Pull the leads out of the connector.

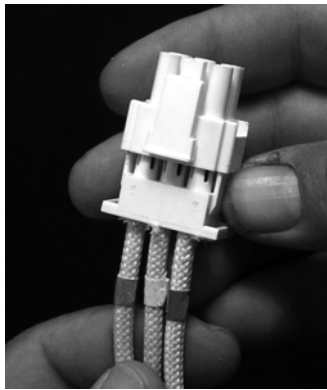

7. Press the pins of the replacement element into the connector in accordance with the diagram below, then close the connector to lock the leads in place.

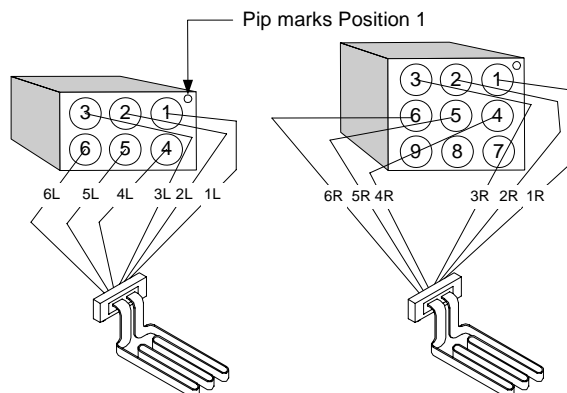

8. Insert the element connectors into the appropriate plug on the rear of the contactor box, ensuring that the latches lock.
9. Insert the temperature probe leads into connector C7 (see illustration below). The white lead goes into position 1 and the red into position 2.

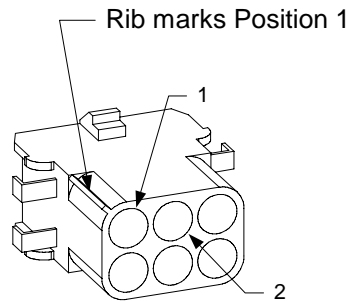

10. Reconnect connector C7 to the wiring harness.
11. Reinstall the back panel and element housing to complete the installation, then reposition the fryer on its deck studs and secure with original nuts and washers.
12. Reconnect the fryer to the electrical power supply, fill with water or cooking oil, and check for proper operation.

7.6 Replacing a Frypot

1. Disconnect the fryer from the electrical power supply and drain the frypot into the drain pan provided with the fryer or other appropriate container.
2. Remove the contactor box (see step 1 of Section 7.3.2). Remove the nuts securing the fryer to the deck and reposition it to gain access to the rear of the fryer.
3. Remove the screws that secure the element housing and back panel to the fryer and remove the element housing and back panel to expose the element assembly and rear of the frypot.
4. Unplug the 6- and 9-pin connectors from the rear of the contactor box, and locate and disconnect connector C7.
5. Remove the screws from the upper corners of the control panel assembly and allow it to swing down (see illustration on page 6-4). Remove the top cap by lifting it straight up and off the fryer.
6. Remove the machine screws and nuts that secure the element assembly to the frypot and remove it from the frypot.
7. Remove the hex head screw that secures the front of the frypot to the cabinet cross brace.
8. Carefully lift the frypot from the fryer and place it upside down on a stable work surface, being careful not to damage the structures at the rear of the frypot.
9. Recover the drain valve and high-limit thermostat from the frypot. Apply Loctite™ PST 567 or equivalent sealant to the threads of the recovered parts and install them in the replacement frypot.

10. Carefully lower the replacement frypot into the fryer. Reinstall the hex head screw removed in step 7 to attach the frypot to the fryer.
11. Position the element assembly in the frypot and reinstall the machine screws and nuts removed in step 6. Plug the 6- and 9-pin connectors into the contactor box and reconnect connector C7.
12. Reinstall the top cap, back panel, element housing, and back panel and close and secure the control panel assembly.
13. Reposition the fryer on its mounting studs and secure with appropriate nuts and washers.
14. Reconnect the fryer to the electrical power supply, fill the frypot with cooking oil/shortening, and check for proper operation.

7.7 Interface Board Diagnostic Chart

The following diagram and charts provide ten quick system checks that can be performed using only a multimeter.

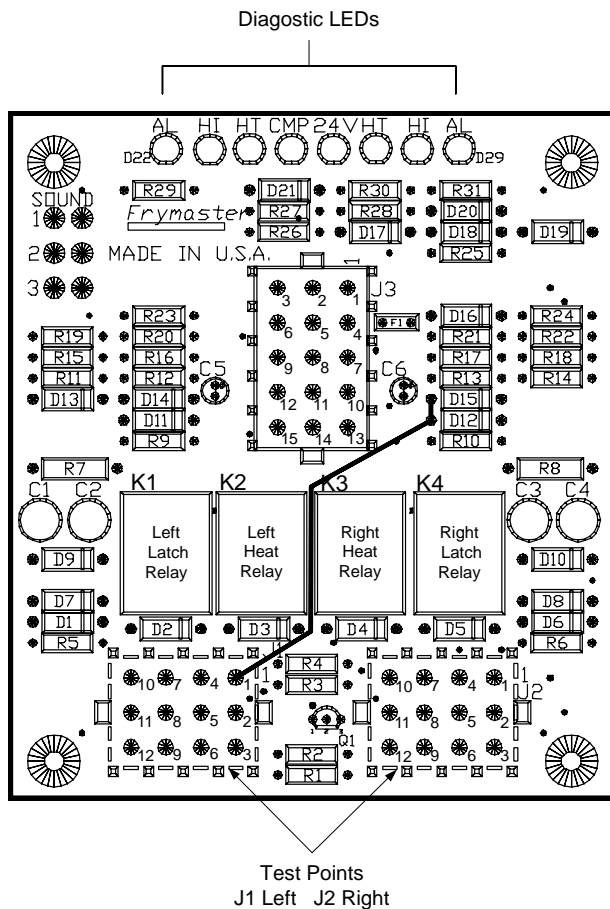

Diagnostic LED Legend

CMP	indicates power from 12V transformer
24	indicates power from 24V transformer
HI (RH)	indicates output (closed) from right latch relay
HI (LH)	indicates output (closed) from left latch relay
HT (RH)	indicates output from right heat relay
HT (LH)	indicates output from left heat relay
AL (RH)	indicates output (open) from right latch relay
AL (LH)	indicates output (open) from left latch relay

Meter Setting	Test	Pin	Pin	Results
12 VAC Power	50 VAC Scale	1 of J2	3 of J2	12-16 VAC
24 VAC Power	50 VAC Scale	2 of J2	Chassis	24-30 VAC
*Probe Resistance (RH)	R X 1000 OHMS	11 of J2	12 of J2	See Chart
*Probe Resistance (LH)	R X 1000 OHMS	3 of J1	2 of J1	See Chart
Hi-Limit Continuity (RH)	R X 1 OHMS	7 of J2	4 of J2	0 - OHMS
Hi-Limit Continuity (LH)	R X 1 OHMS	4 of J1	7 of J1	0 - OHMS
Latch Contactor Coil (RH)	R X 1 OHMS	8 of J2	Chassis	3-10 OHMS
Latch Contactor Coil (LH)	R X 1 OHMS	5 of J1	Chassis	3-10 OHMS
Heat Contactor Coil (RH)	R X 1 OHMS	9 of J2	Chassis	7-15 OHMS
Heat Contactor Coil (LH)	R X 1 OHMS	6 of J1	Chassis	7-15 OHMS

* Disconnect 15-Pin harness from the computer/controller before testing the probe circuit.

7.10 Wiring Diagram

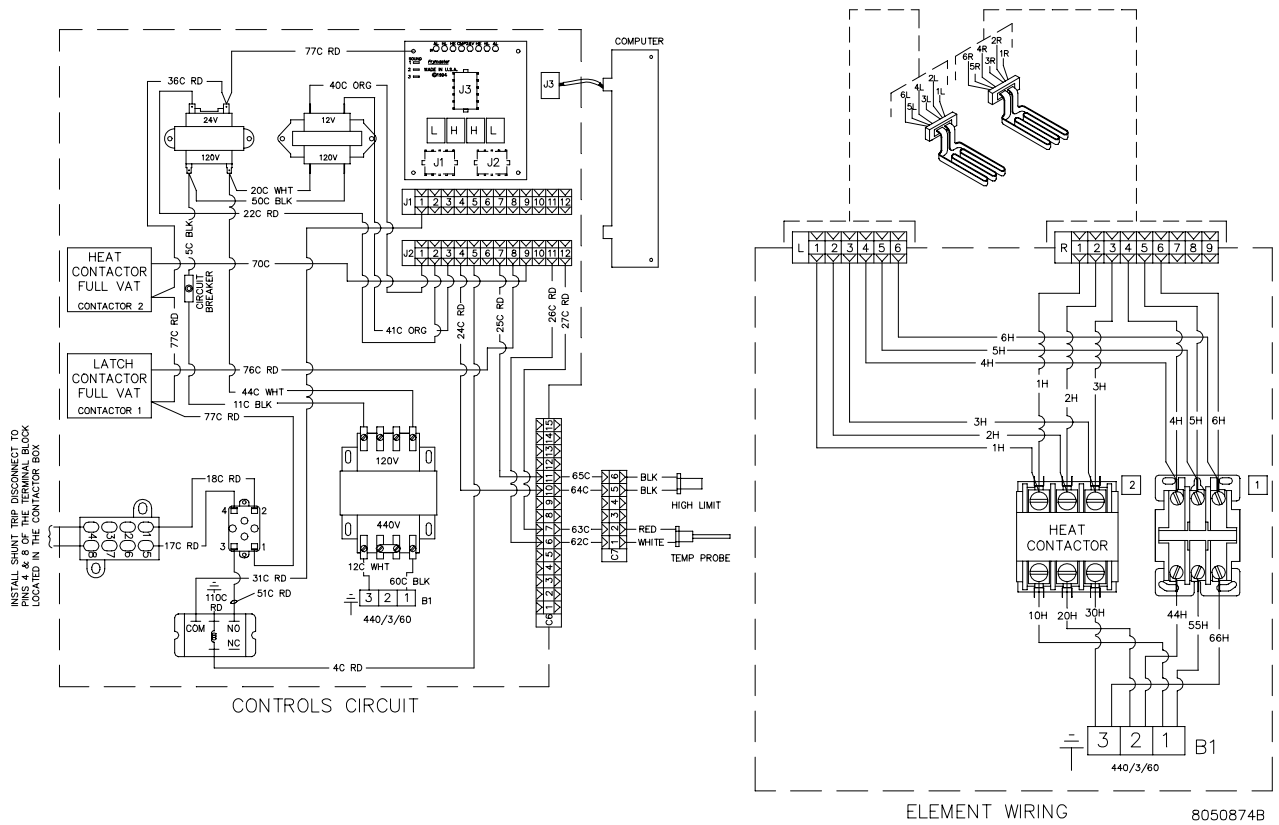

NAVY SUBMARINE ELECTRIC FRYER

CHAPTER 8: PARTS LIST

8.1 Accessories

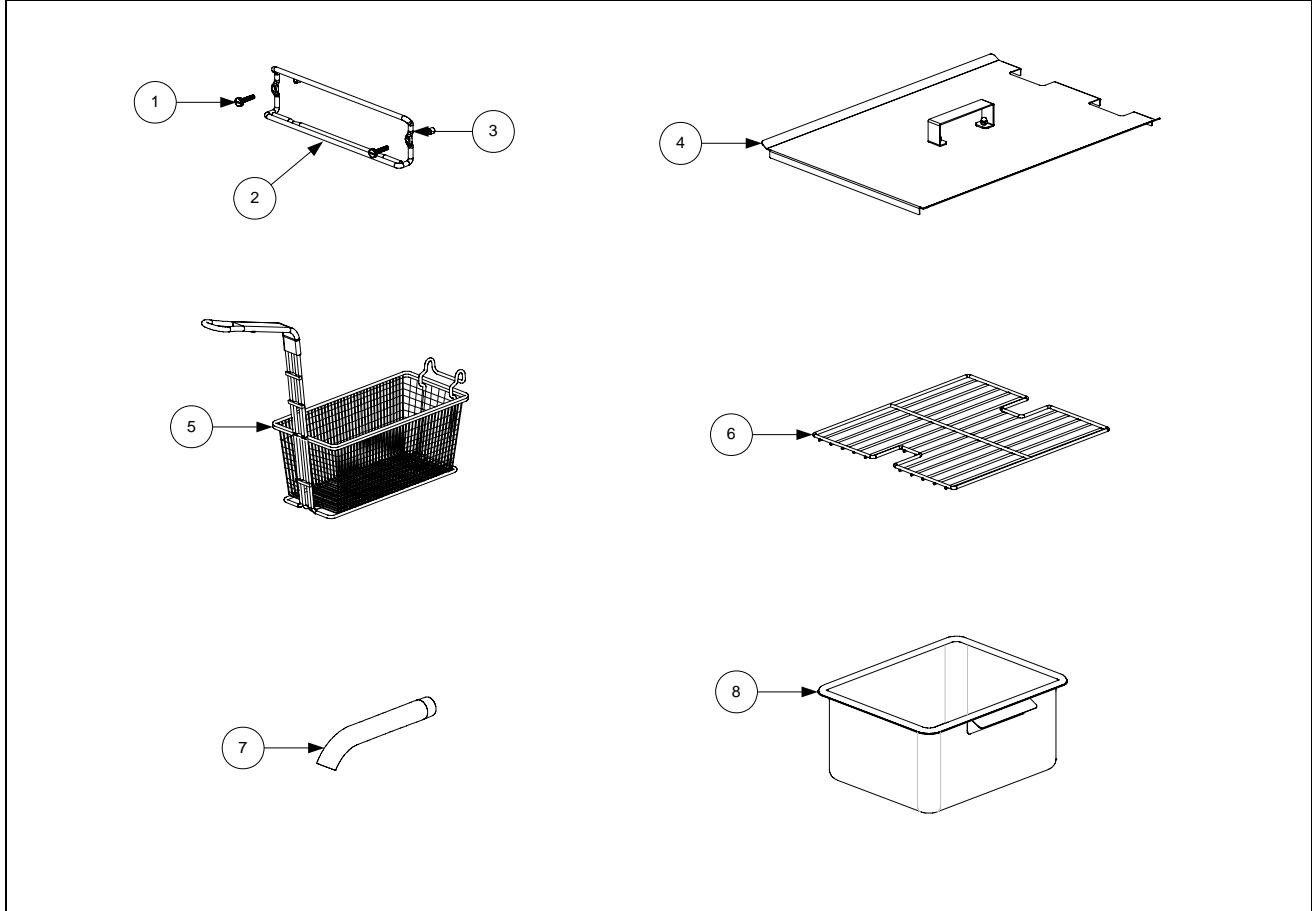

ITEM	PART #	COMPONENT
1	809-0171	Thumbscrew, 1/4 -20 X 1 3/8-inch
2	810-1403	Hanger, Wireform Basket
3	809-0921	Spacer, Basket Hanger
4	806-8558	Cover Assembly, Navy Submarine Frypot
5	812-1386	Basket, Twin
6	803-0132	Rack, Basket Support
7	812-1226	Extension, Drain
8	823-2109	Pan, Submarine Fryer Drain

8.2 Cabinetry

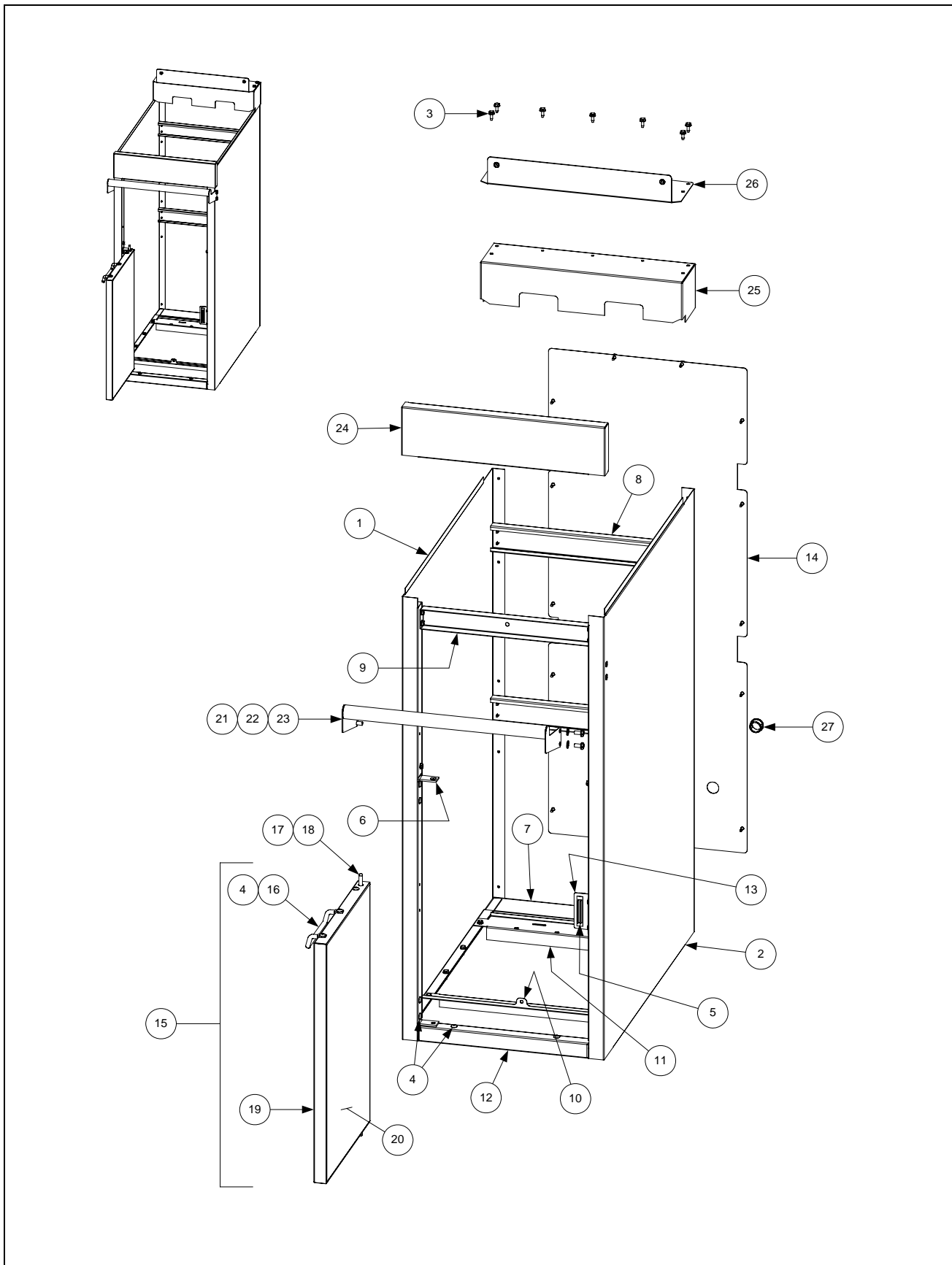

ITEM	PART #	COMPONENT
1	806-9180SP	Side, Submarine Left Cabinet
2	806-9181SP	Side, Submarine Right Cabinet
3	826-1374	Screw, #10 X ½-inch Hex Washer Head (Pkg. of 25)
4	826-1379	Screw, #10 X ½-inch Phillips Truss Head (Pkg. of 10)
5	810-1105	Magnet, Door
6	810-1508	Hinge, Universal Door
7	900-5726	Base, One-Piece Submarine Cabinet
8	900-5742	Brace, Submarine Cabinet Rear
9	900-5743	Brace, Submarine Cabinet Front
10	900-5762	Brace, Submarine Contactor Box Front
11	900-5763	Brace, Submarine Contactor Box Rear
12	910-5754	Panel, Submarine Cabinet Base Cover
13	910-5768	Bracket, Submarine Cabinet Door
14	910-9472	Panel, Submarine Cabinet Back
15	806-8470	Door Assembly, Submarine Cabinet(Items 4 and 16-20)
16	810-1422	Handle, Wireform Door
17	106-0554SP	Pin Assembly, Door
18	810-0275	Spring, Door Pin
19	824-0649	Panel, Submarine Cabinet Door
20	900-5746	Liner, Submarine Cabinet Door
21	823-2718	Handle, Submarine Fryer
22	826-1380	Screw, ¼-20 X ½-inch Slotted Pan Head (Pkg. of 5)
23	809-0192	Washer, ¼-inch Star
24	824-0697	Topcap, Submarine Fryer
25	824-0638	Housing, Submarine Element
26	806-9166SP	Support, Submarine Basket Hanger

8.3 Controller and Contactor Box Components

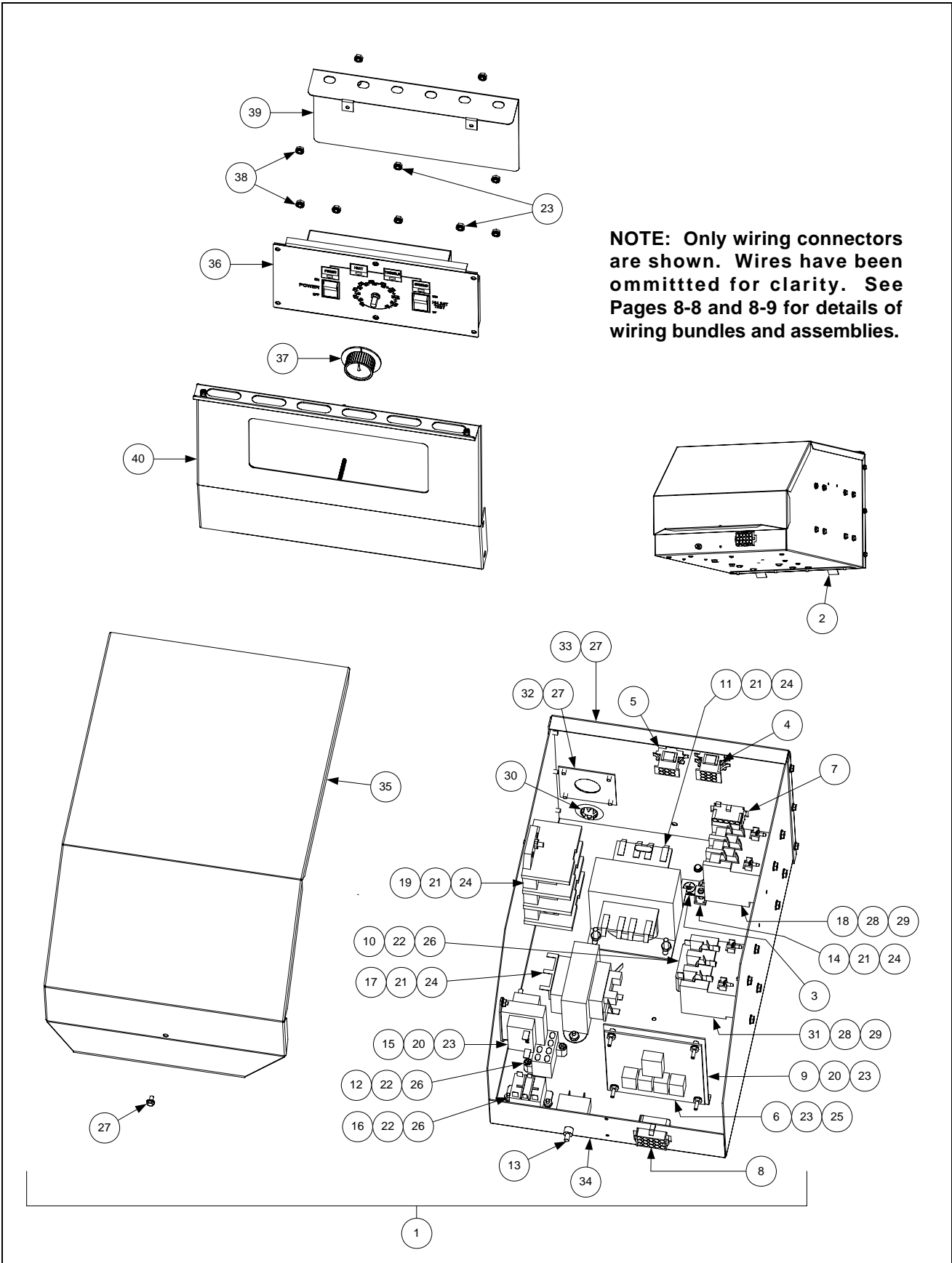

ITEM	PART #	COMPONENT
1	106-0142SP	Contactator Box Assembly, Navy Submarine
2	200-0204	Brace, Contactator Box Rear
3	802-0742	Label, Ground
4	806-7187SP	Wire Assembly, Right Element (see Page 8-8 for schematic)
5	806-7189SP	Wire Assembly, Left Element (see Page 8-8 for schematic)
*	806-8243SP	Wire Assembly, Navy Transformer (see Page 8-8 for schematic)
6	806-7935	Interface Board, Navy Shipboard
7	806-8345SP	Harness, Navy Submarine Fryer (see Page 8-8 for schematic)
8	806-8346SP	Cable, Navy Submarine Controller (see Page 8-8 for schematic)
9	806-8364	Stud Assembly, Interface Board
10	807-0012	Relay, 18 Amp ½ HP 24V Coil
11	807-0064	Transformer, 480V/120V 150VA
12	807-0067	Terminal Block, 8-Pin
13	807-0069	Circuit Breaker, 10 Amp
14	807-0070	Terminal, Ground Lug
15	807-0855	Transformer, 120V/12V 20VA
16	807-1683	Relay, 12VDC
17	807-2181	Transformer, 120V/24V 62VA
18	807-2284	Contactator, 50 Amp Mechanical 24V Coil
19	807-2464	Power Block, Delta
20	826-1365	Screw, 6-32 X ¾-inch Truss Head (Pkg. of 25)
21	809-0123	Screw, #10 X ¾-inch Slotted Truss Head
22	826-1366	Nut, 4-40 Keps Hex (Pkg. of 25)
23	809-0250	Nut, 6-32 Keps Hex
24	826-1376	Nut, 10-32 Keps Hex (Pkg. of 10)
25	809-0349	Spacer, 4mm X 6mm Aluminum
26	826-1359	Screw, 4-40 X ¾-inch Round Head (Pkg. of 25)
27	809-0359	Screw, #8 X ¼-inch Slotted Hex Washer Head
28	826-1374	Screw, #10 X ½-inch Hex Washer Head (Pkg of 25)
29	809-0448	Clip, Tinnerman C1350-10A
30	810-0743	Plug, ¾-inch Hole
31	810-1202	Contactator, 3-Pole 600V 40 Amp
32	900-2752	Plate, Cordset
33	900-4983	Back, Contactator Box
34	900-4984	Box, Contactator
35	900-8304	Cover, Contactator Box
36	806-9215	Controller, Navy Submarine Fryer (<i>Includes Items 23, 37, and 38</i>)
37	810-0387	Knob, Control (<i>Component of Item 36</i>)
38	826-1358	Nut, 6-32 Hex (Pkg. of 25) (<i>Component of Item 36</i>)
*	812-1353	Cable, Controller to Contactator Box (See schematic on Page 8-9)
39	900-8612	Shield, Controller Heat
40	106-3438	Bezel Assembly, Submarine Controller

* Not illustrated.

8.4 Frypot, Elements, and Associated Components

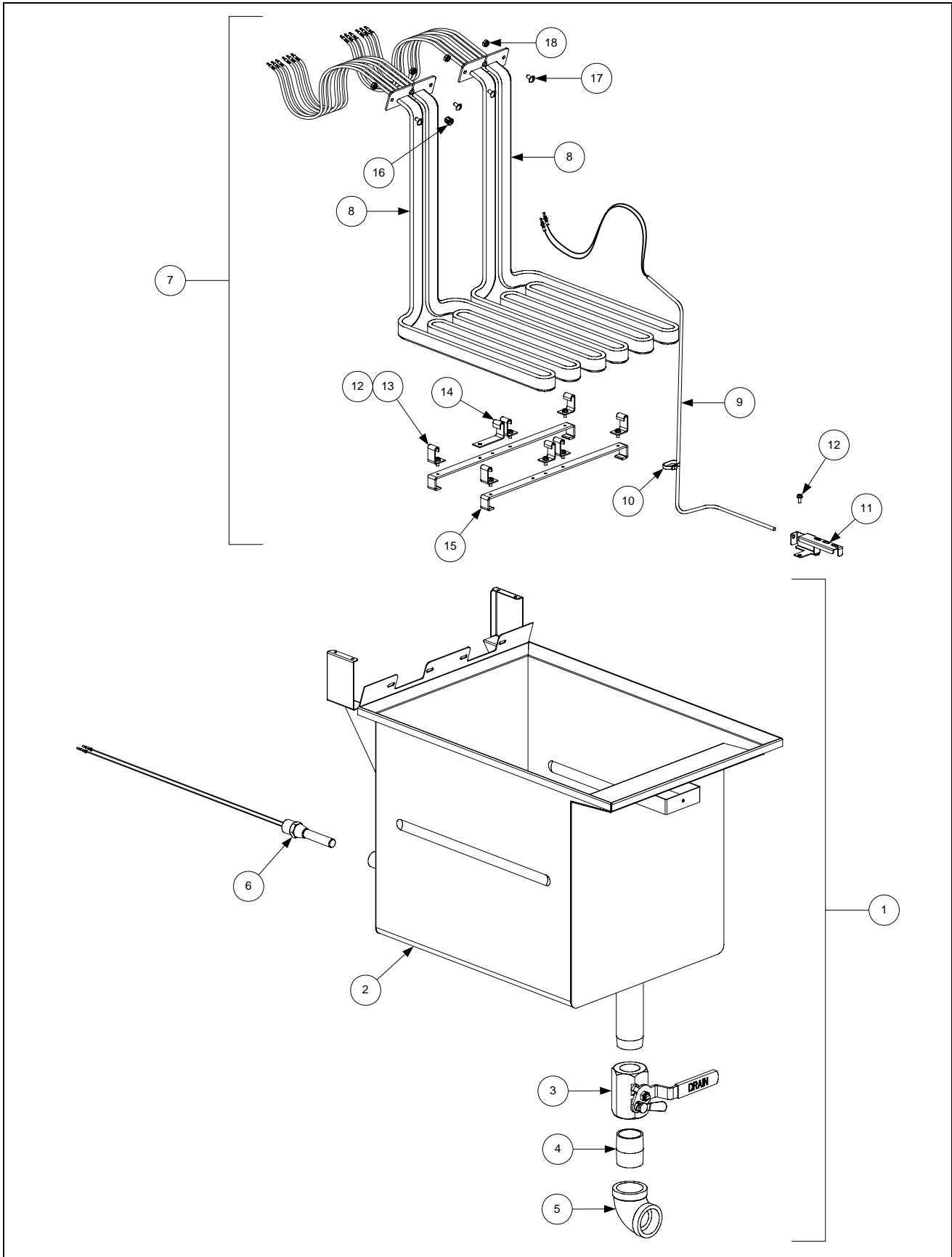

ITEM	PART #	COMPONENT
1	106-0044SP	Frypot and Drain Assembly, Complete (<i>Does not include Item 6</i>)
2	823-2895	Frypot, Navy Submarine
3	810-1569	Valve and Handle Assembly, 1.25-inch Drain
4	813-0391	Nipple, 1.25-inch X Close NPT
5	813-0070	Elbow, 1.25-inch X 90°
6	806-7543	Thermostat Assembly, 425° High-Limit
7	806-9771SP	Element Assembly, Navy Submarine (<i>Does not include Items 17 and 18</i>)
8	807-3268	Element, 440V/7kW Navy Submarine
9	807-3269	Probe, Navy Submarine Temperature
10	809-0567	Tie Wrap, Metal
11	910-5022	Bracket, Temperature Probe
12	809-0518	Screw, 8-32 X 3/8-inch Slotted Hex Washer Head
13	910-2042	Clamp, Element
14	910-5213	Clamp, Element and Probe
15	910-8932	Support, Element
16	826-1339	Bushing, .375-inch Split (Pkg. of 10)
17	826-1330	Screw, 10-32 X 3/8-inch Slotted Truss Head (Pkg. of 25)
18	826-1376	Nut, 10-32 Keps Hex (Pkg. of 10)
*	806-7796SP	High-Limit and Probe Wiring Harness (See Page 8-9 for schematic)

* Not Illustrated.

8.6 Wiring Assemblies and Bundles

CONTACTOR BOX WIRING

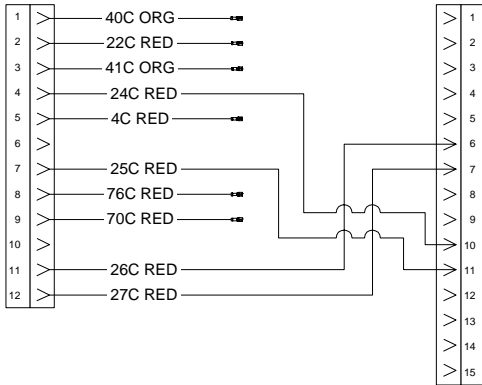

8068345
J2 WIRING HARNESS
(12-Pin Male and 15-Pin Female Connector, 18-Inches Long)

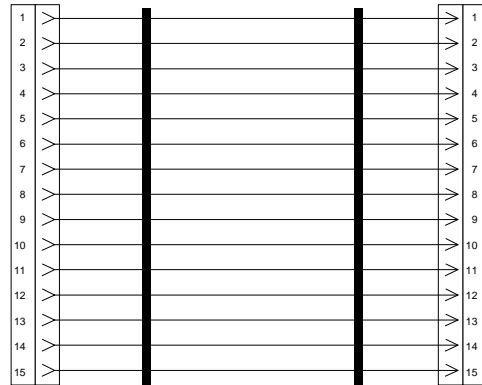

8068346
CONTROLLER CABLE ASSEMBLY
(15-Pin Male and Female Connectors, 9-Inches Long)

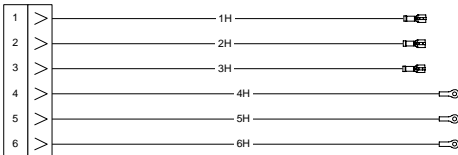

8067189
LEFT ELEMENT CONTACTOR WIRE ASSEMBLY
(6-Pin Female with 6 Wires)

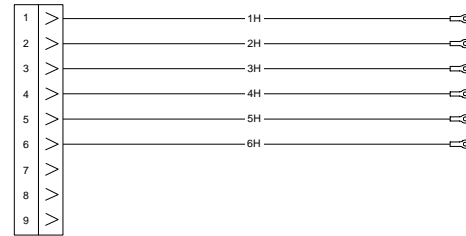

8067187
RIGHT ELEMENT CONTACTOR WIRE ASSEMBLY
(9-Pin Female with 6 Wires)

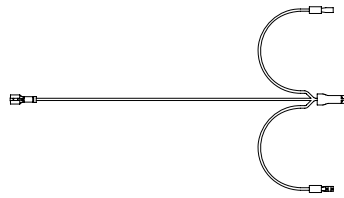

8068243
TRANSFORMER WIRE ASSEMBLY

WIR0286
WIRE BUNDLE, CONTROLS CIRCUIT

WIR0195
WIRE BUNDLE, HEAT CONTACTOR

WIR0184
WIRE BUNDLE, LATCH CONTACTOR

CONTROLLER AND SENSOR WIRING

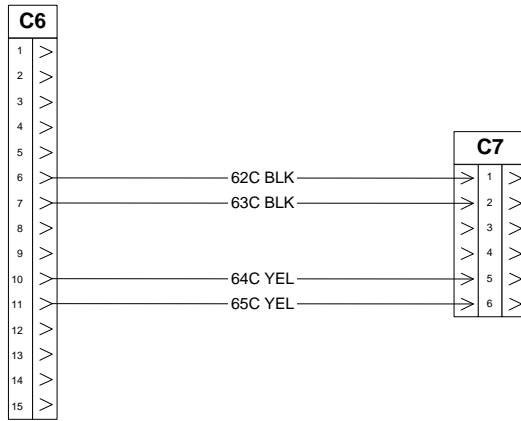

8067796
HIGH LIMIT AND PROBE WIRING HARNESS



8121353
CONTROLLER CABLE
15-Pin Male Connectors on 5-Foot Shielded
Cable (Ferrite Core at Controller End)

8.6 Wiring Connectors and Pin Terminals

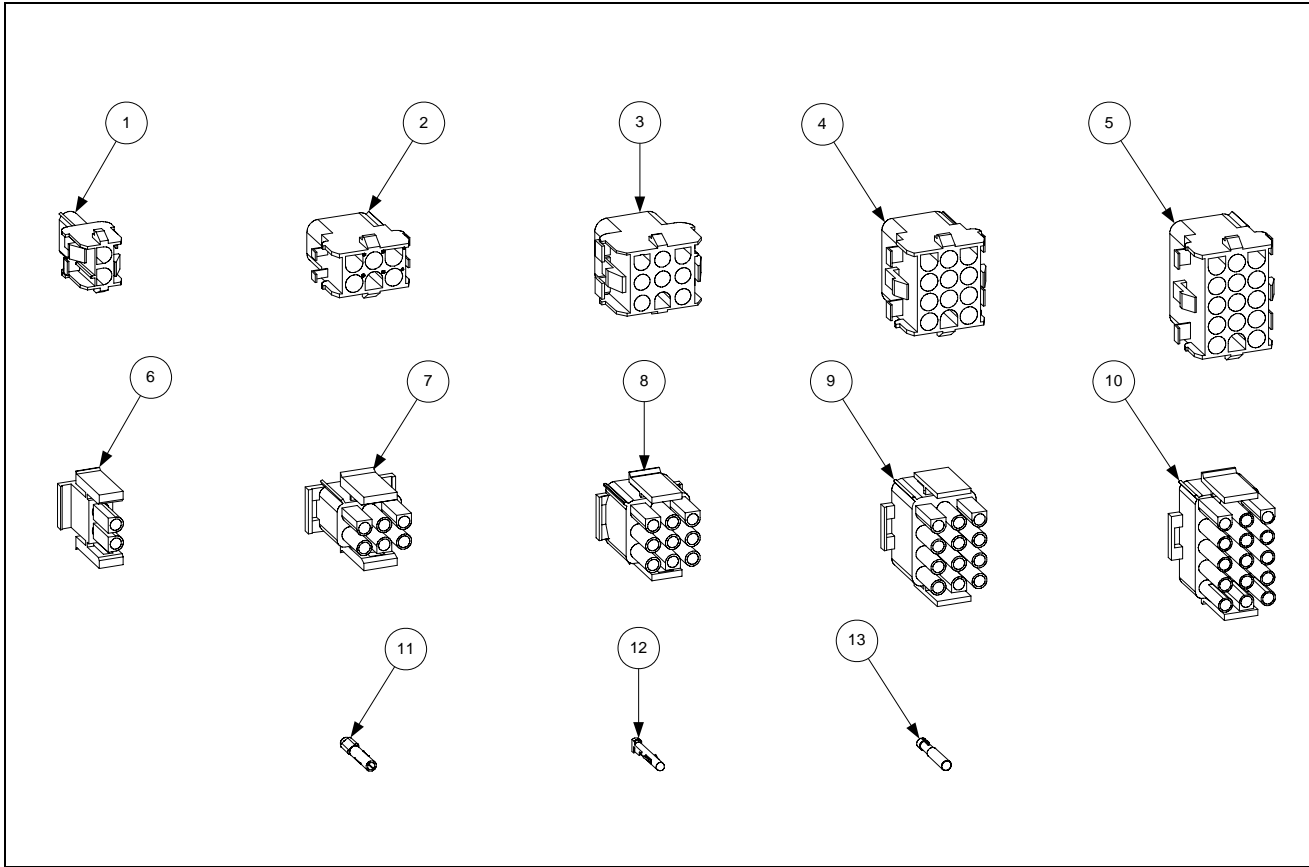

ITEM	PART #	COMPONENT
Connectors		
1	807-1068	2-Pin Female
2	807-0158	6-Pin Female
3	807-0156	9-Pin Female
5	807-0159	12-Pin Female
5	807-0875	15-Pin Female
6	807-1067	2-Pin Male
7	807-0157	6-Pin Male
8	807-0155	9-Pin Male
9	807-0160	12-Pin Male
10	807-0804	15-Pin Male
11	826-1341	Terminal, Female Split Pin (Pkg of 25)
12	826-1342	Terminal, Male Split Pin (Pkg of 25)
13	807-2518	Plug, Mate-N-Lock (Dummy Pin)

* Not illustrated.



Frymaster, L.L.C., 8700 Line Avenue, Shreveport, Louisiana 71106

TEL 1-318-865-1711

FAX (Parts) 1-318-688-2200

(Tech Support) 1-318-219-7135

PRINTED IN THE UNITED STATES

SERVICE HOTLINE
1-800-551-8633

819-6030A
OCTOBER 2011