

PF50S/PF50R

PF50 Parts List

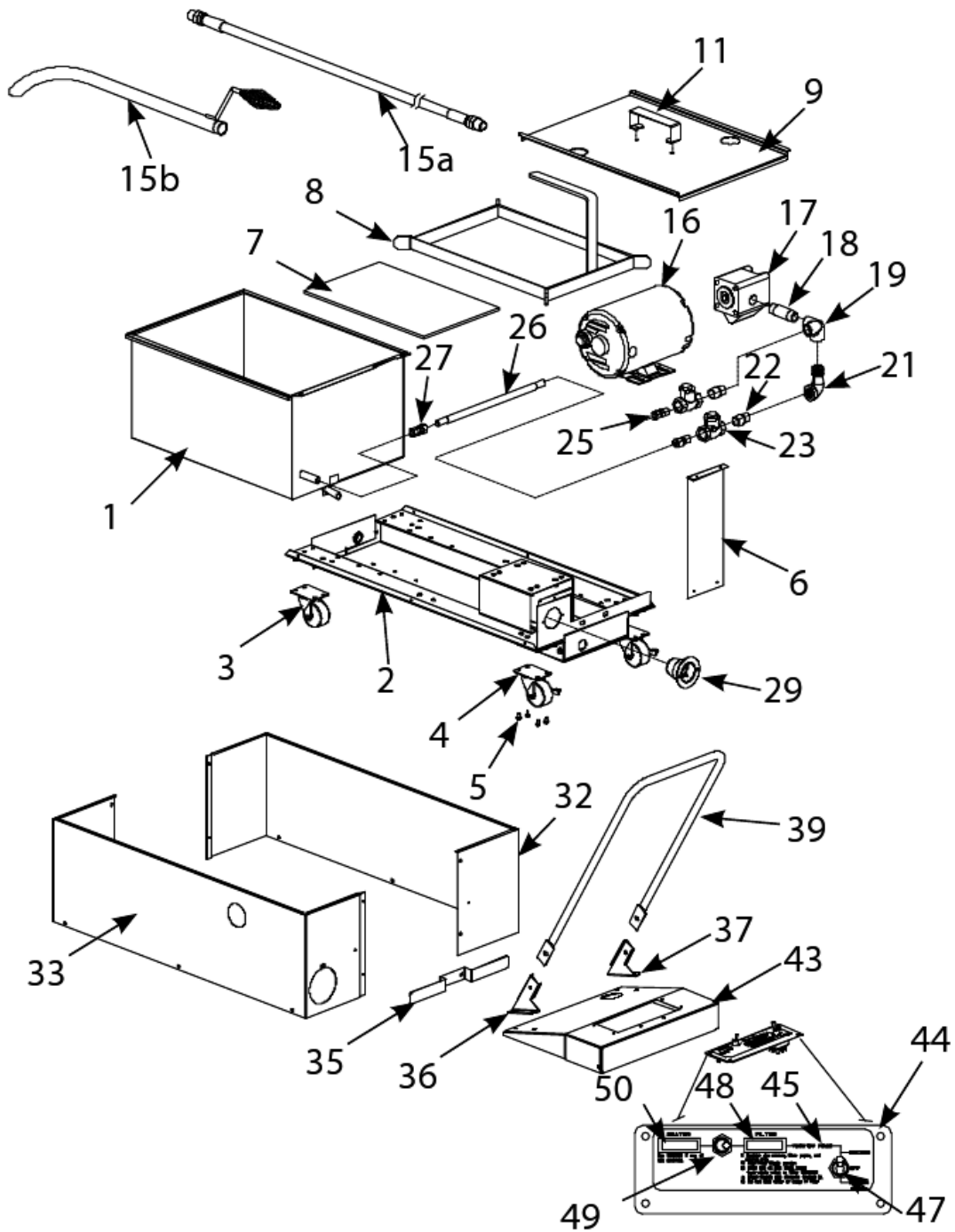

PF50S/PF50R

PF50 Parts List

#	PART #	DESCRIPTION	QTY	Note
1	8232813SP	Pan, Filter	1	
1a	1081340SP	Pan, Filter	1	[1]
2	8065223SP	Base Assembly	1	[2]
3	8102805	Caster - 2"	1	[3]
4	8102806	Caster - 2" Swivel	1	[4]
5	8090475	Screw - #10-32 x 0.3125" Hex	1	
6	9003751	Bracket, Standoff	1	
7	8122300	Screen, Filter Paper Support	1	
7a	8030170	Filter Paper, 16.5" x 25.75"	1	
7b	8030002	Powder, Filter	1	
8	8104440	Ring, Hold-down	1	
9	9103757	Lid, Filter Pan	1	
10	8235950	Crumb basket	1	
11	8260993SP	Handle Kit, Frypot Cover	1	[5]
12	8261379	Screw, #10 X 0.5-inch Phillips Truss Head	10	[6]
13	8090184	Washer, #10 LK ZP	1	[6]
14	8090020	Nut Cap 10-24 NP	1	[6]
15	8063825SP	Hose and Nozzle Assembly - All PF50	1	
15a	8101434	Hose assembly	1	
15b	8101091	Nozzle assembly	1	
16	8261712	Motor and Gasket Kit - 115V/50-60 Hz	1	[7]
16a	8261270	Motor and Gasket Kit - 220-240V/50-60 Hz	1	[7]
17	8261264	Pump Kit - 4 GPM	1	[8]
18	8130265	Nipple - 0.5" x 2.5" NP	1	
19	8130331	Elbow, V-Side Outlet 0.5" NPT	1	
20	8063844	Heater Strip, 120V 40W	1	
21	8130165	Elbow - 0.5" x 90° NPT Street	1	
22	8130022	Nipple, 0.5" Close NPT BM	1	
23	8100430	Valve, Swing Check - 0.5"	1	
25	8130544	Union, 0.5 NPT x 0.5" Flexline Hose	1	
26	8101435	Flexline - 0.5" OD x 12" L - SS	1	
27	8130545	Union, 0.5 x 0.5" Flexline Hose	1	
28	8261467	Hose Replacement Kit, PF Series Before 07/97	1	
29	8071219	Receptacle - 3-Wire	1	[9]
30	8071224	Cord, Power - 3-Wire 115V	1	
31	8070154	Power Cord - 120V w/Ground Plug	1	
32	9108587	Panel, Outer - Left Side	1	
33	9108586	Panel, Outer - Right Side	1	
34	2100795	Panel, Outer - Right Side- PF50 230V Export Only	1	
35	9103788	Holder, Power Cord	1	
36	9122616	Bracket, Handle- Right	1	
37	9112616	Bracket, Handle- Left	1	
38	8261380	Screw, 0.25-20 X 0.5-inch Slotted Pan Head	5	[10]
39	8103508	Handle, Portable Filter	1	
40	8261389	Screw - 0.25"-20 x 0.75" Hex Head ZP	10	
41	8100219	Spacer, Handle Bolt	1	

PF50 Parts List

PF50S/PF50R

PF50 Parts List

#	PART #	DESCRIPTION	QTY	Note
42	8090047	Nut, Cap- 0.25-20 High Profile S/S	1	
43	8240403	Panel, Control	1	
44	9100982	Panel, Switch	1	
45	8021302	Label, Switch Panel - PF50 Filters Only	1	
46	8021438	Label, Switch Plate	1	
47	8071040	Switch, Toggle- 3-Way, PF50 Filters Only	1	[11]
48	8071060	Light, Indicator- Red Lens (Filter Indicator Light) 120V	1	[12]
49	8071041	Toggle Switch - 2-Way	1	
50	8071061	Light, Indicator- White Lens (Heater Indicator Light) 120V	1	[13]

PART NOTES:

- [1] - For units with only one pickup tube +
- [2] - Includes items 3 & 4
- [3] - Without Brake
- [4] - With Brake
- [5] - Includes Screws, Nuts, Washers and Threadlocking Compound
- [6] - Lid Handle
- [7] - Includes Motor and Gasket
- [8] - Includes Pump and Gasket
- [9] - 120V Domestic Units Only
- [10] - For Handle Bracket
- [11] - PF50S Filters, Use Item #49
- [12] - Filter Indicator Light
- [13] - Heater Indicator Light