



**HDC, CFHDC, SCFHDC,
FPHDC, LHDC, Y/KSCF/C/HC, BK1814**

**(High Efficiency Common Cabinet
Decathlon Fryers)**

**High Efficiency Decathlon (HD)
Series Gas Fryers
Service & Parts Manual**



Dean, a member of the Commercial Food Equipment Service Association, recommends using CFESA Certified Technicians.

**PRINTED IN THE UNITED STATES
OF AMERICA**

**24-Hour Service Hotline
1-800-551-8633
EMAIL: fryservice@mtwfs.com**



08/2016

Please read all sections of this manual and retain for future reference.

This product has been certified as commercial cooking equipment and MUST be installed by professional personnel as specified. Installation, maintenance and repairs should be performed by your FRYMASTER AUTHORIZED SERVICER.

 DANGER

Do not store or use gasoline or other flammable vapors and liquids in the vicinity of this or any other cooking appliance.

 DANGER

Instructions explaining procedures to be followed MUST be posted in a prominent location in the event the operator detects a gas leak. This information can be obtained from the local gas company or gas supplier.

 WARNING

Improper installation, adjustment, alteration, service or maintenance can cause property damage, injury or death. Read the installation, operating and maintenance instructions thoroughly before installing or servicing this equipment.

 DANGER

Safe and satisfactory operation of your equipment depends on proper installation. Installation MUST conform with local codes, or in absence of local codes, with the National Fuel Gas Code, ANSI Z223.1; The Natural Gas Installation Code, CAN/CGA-B149.1; The Propane Installation Code, CAN/CGA-B149.2; or The latest edition of the National Electric Code, N.F.P.A. 70.

NOTICE

If, during the warranty period, the customer uses a part for this Manitowoc Food Service equipment other than an unmodified new or recycled part purchased directly from Frymaster and Dean, or any of its authorized service centers, and/or the part being used is modified from its original configuration, this warranty will be void. Further, Frymaster and Dean and its affiliates will not be liable for any claims, damages or expenses incurred by the customer which arise directly or indirectly, in whole or in part, due to the installation of any modified part and/or part received from an unauthorized service center.

 DANGER

The crumb tray in fryers equipped with a filter system must be emptied into a fireproof container at the end of frying operations each day. Some food particles can spontaneously combust if left soaking in certain shortening material. Additional information can be obtained in the filtration manual included with the system.

 DANGER

The front ledge of the fryer is not a step. Do not stand on the fryer. Serious injury can result from slips or contact with the hot oil.

 **WARNING**

Drawings and photos used in this manual are intended to illustrate operational, cleaning and technical procedures and may not conform to on-site management operational procedures.

 **WARNING**

No structural material on the fryer should be altered or removed to accommodate placement of the fryer under a hood. Questions? Call the Frymaster and Dean Service Hotline at 1-800-551-8633.

This equipment is to be installed in compliance with the basic plumbing code of The Building Officials and Code Administrators International, Inc. (BOCA) and the Food Service Sanitation Manual of the Food and Drug Administration.

COMPUTERS
FCC

This device complies with Part 15 of the FCC rules. Operation is subject to the following two conditions:
1) This device may not cause harmful interference, and 2) This device must accept any interference received, including interference that may cause undesired operation. While this device is a verified Class A device, it has been shown to meet the Class B limits.

CANADA

This digital apparatus does not exceed the Class A or B limits for radio noise emissions as set out by the ICES-003 standard of the Canadian Department of Communications.

Cet appareil numérique n'émet pas de bruits radioélectriques dépassant les limites de classe A et B prescrites dans la norme NMB-003 édictée par le Ministre des Communications du Canada.

 **DANGER**

THIS PRODUCT CONTAINS CHEMICALS KNOWN TO THE STATE OF CALIFORNIA TO CAUSE CANCER AND/OR BIRTH DEFECTS OR OTHER REPRODUCTIVE HARM.

Operation, installation, and servicing of this product could expose you to airborne particles of glasswool or ceramic fibers, crystalline silica, and/or carbon monoxide. Inhalation of airborne particles of glasswool or ceramic fibers is known to the State of California to cause cancer. Inhalation of carbon monoxide is known to the State of California to cause birth defects or other reproductive harm.

 **WARNING**

Do not bang fry baskets or other utensils on the fryer's joiner strip. The strip is present to seal the joint between the fry vessels. Banging fry baskets on the strip to dislodge shortening will distort the strip, adversely affecting its fit. It is designed for a tight fit and should only be removed for cleaning.



**High Efficiency Decathlon (HD) Series Gas Fryers
Service and Parts Manual**

TABLE OF CONTENTS

1. SERVICE PROCEDURES	
1.1 Functional Description.....	1-1
1.2 Accessing Fryers for Service.....	1-7
1.3 Cleaning the Gas Valve Vent Tube (if applicable).....	1-9
1.4 Adjusting Burner Manifold Gas Pressure.....	1-9
1.5 Adjusting the Pilot Flame.....	1-10
1.6 Calibrating the Thermatron Controller and Backup Thermostat.....	1-10
1.7 Replacing Fryer Components.....	1-11
1.8 Troubleshooting and Problem Isolation.....	1-29
1.9 Troubleshooting Guides.....	1-37
1.10 Wiring Diagrams.....	1-38
1.11 Probe Resistance Charts.....	1-52
2. PARTS LIST	
2.1 Decathlon(HDC) Primary Components.....	2-1
2.2 Orifices.....	2-16
2.3 Additional Optional Components and Controllers.....	2-17
2.4 Drain Components.....	2-19
2.5 Oil Return System.....	2-23
2.6 Additional Oil Return Components.....	2-25
2.7 Oil Disposal (Popeye's and Church's).....	2-27
2.8 Oil Return Wand.....	2-28
2.9 Over-the-Top Oil Return System.....	2-29
2.10 Filtration Components.....	2-30
2.11 Basket Lift Components.....	2-38
2.12 Accessories.....	2-40
2.13 Fasteners (Screws, Nuts, Bolts).....	2-41
2.14 Flexlines.....	2-42
APPENDIX: Pre-Common Cabinet HD65 Parts List.....	2-43

FINDING YOUR WAY AROUND THE DEAN HIGH EFFICIENCY DECATHLON

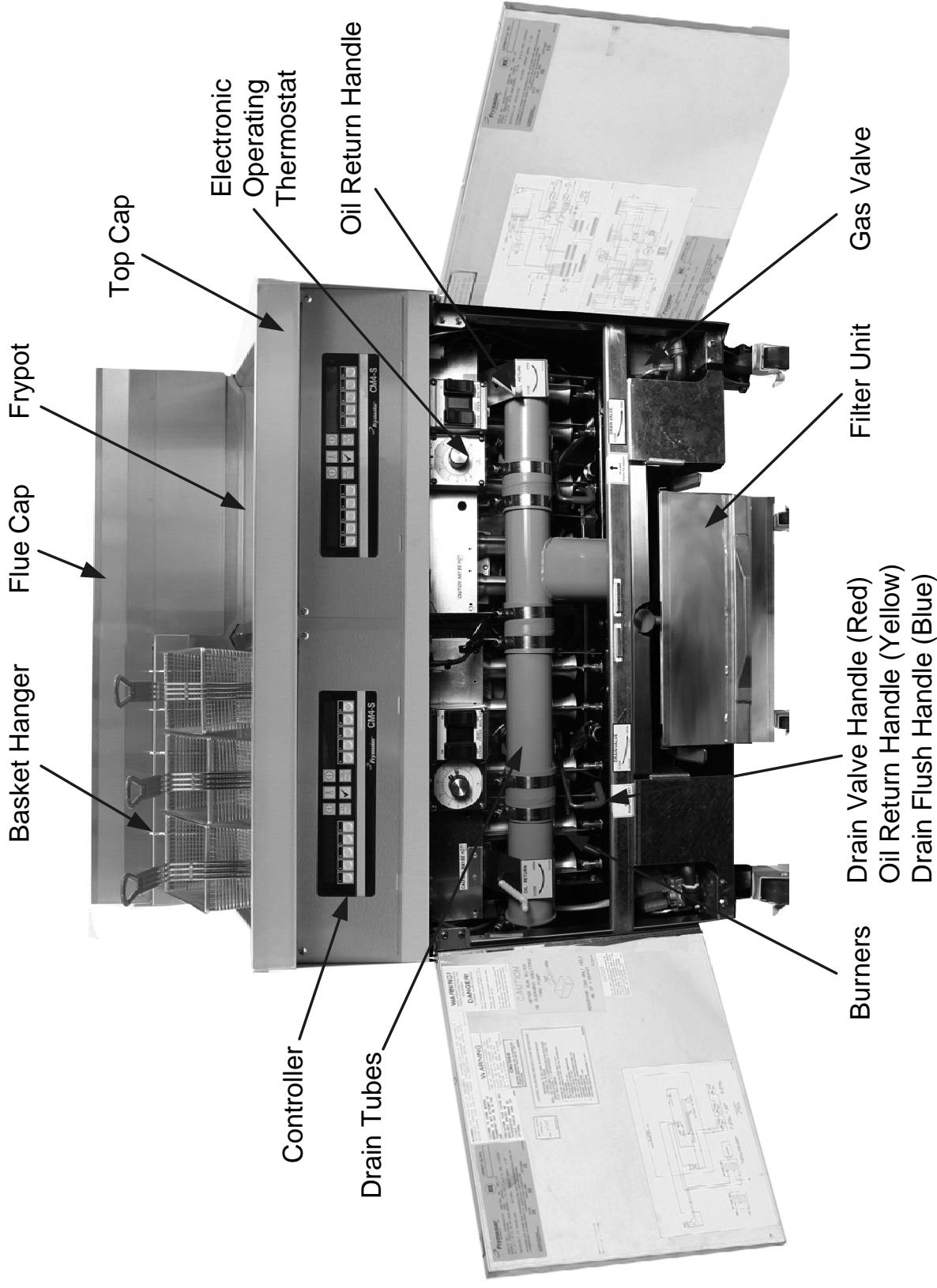

Note: The appearance of your fryer may differ slightly from that shown depending upon configuration and date of manufacture.

HIGH EFFICIENCY DECATHLON SERIES GAS FRYERS

CHAPTER 1: SERVICE PROCEDURES

1.1 Functional Description

High Efficiency Decathlon (HD) Series gas fryers contain a welded stainless steel frypot heated by gas flames diffused evenly through tubes built into the frypot.

Flames originate from orifices in a burner manifold positioned beneath cast-steel burners. The burners are positioned in the tube openings at the front of the frypot. The diameter of the orifices differs for natural and LP gas as indicated in the accompanying table.

GAS INFORMATION (Altitudes of 2000 feet or less)							
MODEL	INPUT (BTU)	GAS TYPE	ORIFICE MM (INCH)	ORIFICE PART NO.	QTY	EQUIPMENT PRESSURE	
						MBAR	INCH W.C.
HD50G	95	NAT	2.26(#43)	810-2938	4	10	4
		LP	1.40(#54)	810-2939	4	27.5	10
HD60/63/65G	125	NAT	2.26(#43)	810-2938	5	10	4
		LP	1.40(#54)	810-2939	5	27.5	10

An electromechanical gas valve regulates gas flow to the manifold. HD Series gas fryers are equipped with either a 24V valve system. Unit configurations include either a pilot ignition system or an electronic ignition system.

HIGH EFFICIENCY DECATHLON SERIES GAS FRYERS

CHAPTER 1: SERVICE PROCEDURES

1.1 Functional Description (cont.)

Pilot System Configuration

The pilot system is comprised of the pilot orifice, pilot hood, and a thermopile (some systems incorporate a thermocouple). The pilot serves two purposes: light the burner and heat the thermopile. In operation, the thermopile is in contact with the pilot flame and generates millivolts. The millivolt output energizes the gas valve pilot coil, which in turn opens the pilot valve. If the pilot flame is extinguished, the gas valve pilot coil loses voltage and the pilot valve closes. The main valve of the gas valve will not open if the pilot valve is not open. The pilot flame must be manually lit when the fryer is first placed into operation. A separate 24V circuit, activated by the fryer ON/OFF switch, provides voltage through the Thermatron to the gas valve main coil, which opens the main valve.

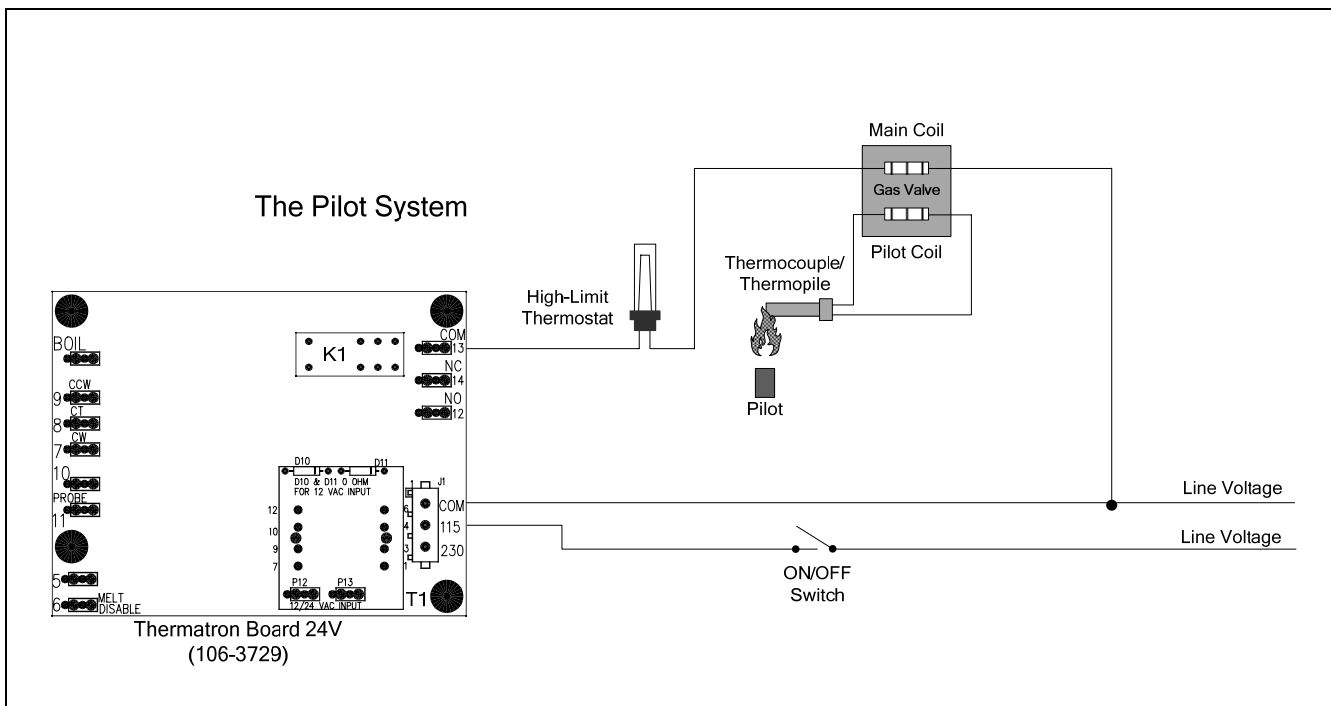

Electronic Ignition Configuration

In units configured for electronic ignition, an ignition module connected to an ignitor assembly replaces the pilot system. The ignition module performs three important functions: It provides an ignition spark, supplies voltage to the gas valve, and proofs the pilot flame.

The module contains a 90-second time delay circuit and a coil that activates the gas valve. The ignitor assembly consists of a spark plug, a pilot, and a flame sensor element.

HIGH EFFICIENCY DECATHLON SERIES GAS FRYERS

CHAPTER 1: SERVICE PROCEDURES

Electronic Ignition Configuration (cont.)

At start-up the ON/OFF switch is placed in the ON position, supplying 12 VDC to the heat control circuitry in the controller or controller and to one side of the heat relay coil on the interface board. If resistance in the temperature probe indicates the temperature in the frypot is below 180°F (82°C), the current flows through a melt cycle circuit where a timer switch alternately closes for 3 seconds and opens for 24 seconds. If the temperature is 180°F (82°C) or above, the current flows through a heat circuit, bypassing the timer switch. In either case, current is supplied to the other leg of the heat relay coil which then closes an electronic switch in the 24 VAC circuit to provide current to the ignition module. **NOTE:** The listed melt cycle times and exit temperature pertain to the Compu-Fry controller only.

Circuitry in the ignition module sends 24 VAC current to the gas valve via a normally closed high-limit switch and a drain safety switch. Simultaneously, the module causes the ignitor to spark for up to 90 seconds to light the pilot flame. A flame sensor verifies that the pilot is lit by measuring the flow of microamps through the flame. If the pilot does not light (or is extinguished), current to the ignition module is interrupted, preventing the main valve from opening, and the ignition module "locks out" until the power switch is turned OFF, then back ON.

A temperature probe monitors the temperature in the frypot. When the programmed setpoint temperature is reached, resistance in the probe causes the heat cycle circuitry in the controller to interrupt current flow through the heat relay. This in turn interrupts the 24 VAC current to the ignition module, resulting in closure of the gas valve.

NOTE: Unlike previous modules, microamp readings on these black modules will move up and down as the module pulses on and off and this is an indication that the module is functioning.

Control Options

HD Series gas fryers may be equipped with Thermatron controls, Compu-Fry controllers, 3-Lane controllers or FAST controllers.

In fryers equipped with Thermatron controls, the fryer is turned on and off by means of a rocker switch and the temperature is set by adjusting a potentiometer. An interface board is located in the component box (shield) behind the control panel (controller-equipped) or a Thermatron board is located in a component box inside the cabinet (Thermatron-equipped).

Interface Boards

The interface board provides a link between the controller/controller and the fryer's individual components without requiring excessive wiring, and allows the controller to execute commands from one central point. Two types of interface boards may be used in HD Series gas fryers; the type used depends on the fryer configuration.

In units configured for electronic ignition and constant pilot, P/N 826-2434 is used; in units configured with a manually lit pilot (non-electronic ignition), P/N 826-2425 is used.

HIGH EFFICIENCY DECATHLON SERIES GAS FRYERS

CHAPTER 1: SERVICE PROCEDURES

Interface Boards (cont.)

106-3729 (24V): These boards are used in HD fryers equipped with Thermatron control systems.

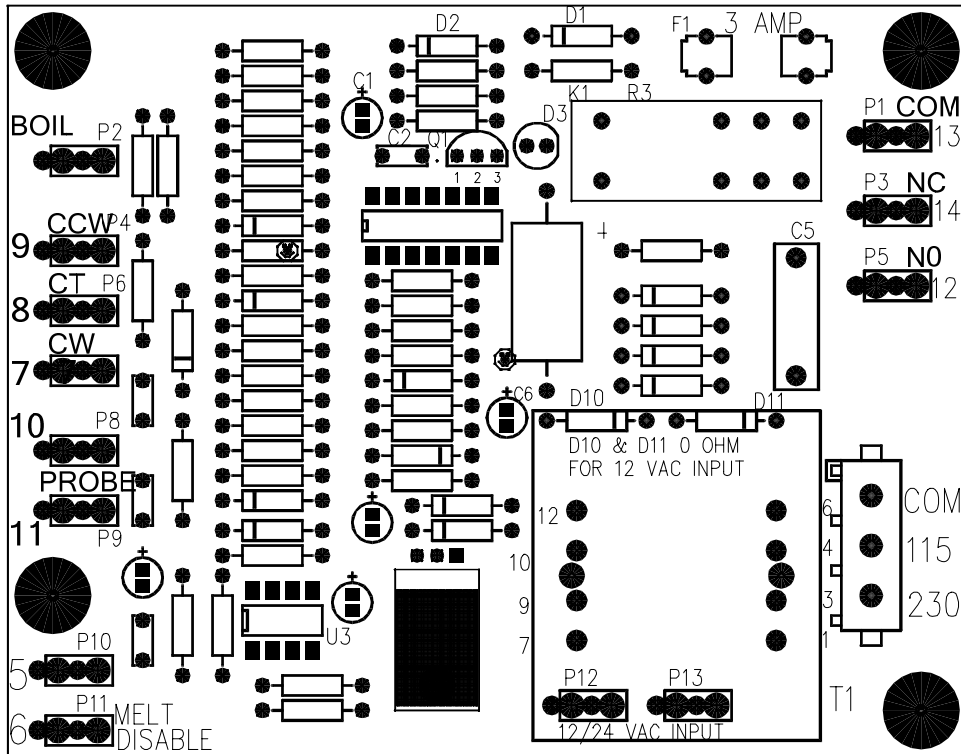

THERMATRON BOARD P/N 106-3729

Thermatron systems incorporate a temperature probe, a potentiometer, and a temperature control circuit board. This system is more accurate and reliable than a standard thermostat. The temperature probe measures oil temperature via resistance (ohms); as oil temperature rises, resistance decreases. The potentiometer sets the oil temperature via resistance (ohms). The temperature control circuit board compares the resistance from the probe and potentiometer and cycles the burner on and off as necessary.

HIGH EFFICIENCY DECATHLON SERIES GAS FRYERS

CHAPTER 1: SERVICE PROCEDURES

Interface Boards (cont.)

826-2434: These interface boards are used in HD fryers equipped with electronic ignition and constant pilot.

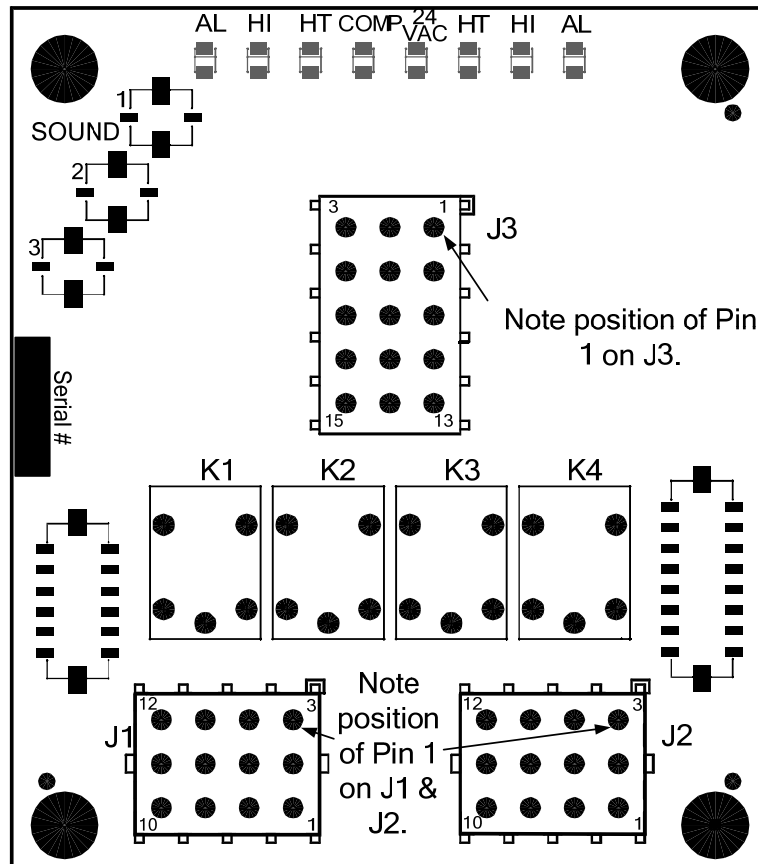

INTERFACE BOARD P/N 826-2434
Used on fryers equipped with electronic ignition and constant pilot.

HIGH EFFICIENCY DECATHLON SERIES GAS FRYERS CHAPTER 1: SERVICE PROCEDURES

Interface Boards (cont.)

FREQUENTLY USED TEST POINTS FOR HIGH EFFICIENCY DECATHLON (HD) FRYERS 106-6669 INTERFACE BOARD			
Test	Meter Setting	Pins	Test Results
12VAC Power to Controller	50 VAC Scale	1 and 3 on J3	12-18
12VDC Power to Right BL Relay	50 VDC Scale	4 on J2 and 5 on J2	12-18
12VDC Power to Left BL Relay	50 VDC Scale	7 on J1 and 5 on J2	12-18
24VAC Power to High-Limit	50 VAC Scale	6 on J2 and GROUND	22-28
24VAC Power	50 VAC Scale	2 on J2 and GROUND	22-28
24VAC Power To 24VAC Gas Valve	50 VAC Scale	7 on J2 and GROUND	22-28
Probe Resistance*	R x 1000 Ohms	10 and 11 on J2	**
* Disconnect 15-pin harness from controller before testing probe circuit.			
** See Probe Resistance Chart at the end of this chapter.			

HIGH EFFICIENCY DECATHLON (HD) FRYER LED DIAGNOSTIC LIGHTS (106-6669 INTERFACE BOARD)	
CMP	Indicates power from 12V transformer.
24V	Indicates power from 24V transformer.
HI	Indicates output (closed) from latch relay (K4).
HT	Indicates output from heat relay (K3).
AL	Indicates output (open) from latch relay (K4).

The board contains four relays. K3 is the heat relay and K4 is the latch relay. K1 and K2 are only used in "dual" or "split" pot applications.

NOTE: *On factory-original units not equipped with basket lifts and on service interface boards, the board will have no basket lift relays installed.*

HIGH EFFICIENCY DECATHLON SERIES GAS FRYERS

CHAPTER 1: SERVICE PROCEDURES

Thermostats

Different types of thermostats are used in High Efficiency Decathlon Series gas fryers, depending on fryer configuration.

Fryers equipped with a *Thermatron* use a dial to adjust temperature. In this configuration, the probe resistance varies inversely with the temperature. *As the temperature rises, resistance decreases at a non-linear rate.* A chart is located at the end of this chapter.

Fryers equipped with controller controls have a *temperature probe*. In this configuration, the probe resistance varies directly with the temperature. *As the temperature rises, resistance increases at a rate of approximately 2 ohms for every 1°F (approximately 3.7 ohms for every 1°C).* Circuitry in the controller monitors the probe resistance and controls burner firing when the resistance exceeds or falls below programmed temperatures (setpoints). The temperatures are programmed by means of a keypad on the face of the controller.

All HD Series gas fryers are equipped with a *high-limit thermostat*. In the event that the fryer fails to control the oil temperature, the high-limit thermostat prevents the fryer from overheating to flash point. The high-limit thermostat acts as a normally closed power switch that opens when exposed to temperatures above 450°F/232°C.

1.2 Accessing Fryers for Service

 **DANGER**

Moving a fryer filled with cooking oil may cause spilling or splattering of the hot liquid. Follow the draining instructions included with the fryer before attempting to relocate a fryer for servicing.

1. Shut off the gas supply to the unit. Unplug the power cords. Remove any attached restraining devices.
2. Disconnect the unit from the gas supply.
3. Relocate the fryer for service accessibility.
4. After servicing is complete, reconnect the unit to the gas supply, reattach restraining devices, and plug in the electrical cords.

 **DANGER**

No structural material on the fryer should be altered or removed to accommodate placement of the fryer under a hood. Questions? Call the Frymaster Dean Service Hotline at 1-800-551-8633.

HIGH EFFICIENCY DECATHLON SERIES GAS FRYERS

CHAPTER 1: SERVICE PROCEDURES

Restraints

Once the fryer has been positioned at the frying station, use a carpenter's level placed across the top of the frypot to verify that the unit is level, both side-to-side and front-to-back.

To level fryers equipped with legs, the bottom of the legs can be screwed out up to one inch for leveling. Legs should also be adjusted so that the fryer(s) are at the proper height in the frying station.

For fryers equipped with casters, there are no built-in leveling devices. The floor where the fryers are installed must be level.

When the fryer is leveled in its final position, install the restraints provided with the unit to limit its movement so that it does not depend on or transmit stress to the electrical conduit or connection. Install the restraints in accordance with the provided instructions (see illustration below). If the restraints are disconnected for service or other reasons, they must be reconnected before the fryer is used.

⚠ DANGER

Adequate means must be provided to limit the movement of this appliance without depending on or transmitting stress to electrical conduits or gas supply line. A restraint kit is provided with the fryer. If the restraint kit is missing contact your local Frymaster Factory Authorized Service Center (FASC) for part number 826-0900.

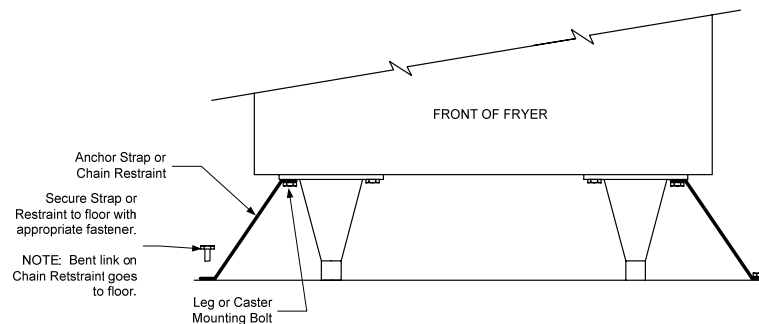

NOTE: If you need to relocate a fryer installed with legs, remove all weight from each leg before moving. If a leg becomes damaged, contact your service agent for immediate repair or replacement.

⚠ DANGER

Hot oil can cause severe burns. Avoid contact. Under all circumstances, oil must be removed from the fryer before attempting to move it to avoid oil spills, falls, and severe burns. This fryer may tip and cause personal injury if not secured in a stationary position.

HIGH EFFICIENCY DECATHLON SERIES GAS FRYERS

CHAPTER 1: SERVICE PROCEDURES

1.3 Cleaning the Gas Valve Vent Tube (if applicable)

1. Set the fryer power switch and the gas valve to the OFF position.
2. Carefully unscrew the vent tube from the gas valve. **NOTE:** The vent tube may be straightened for ease in removal.
3. Pass a piece of wire through the tube to remove any obstruction. Remove the wire and blow through the tube to ensure it is clear.
4. Reinstall tube and bend so that the opening is pointing downward.

1.4 Adjusting Burner Manifold Gas Pressure



WARNING
This task should be performed by qualified service personnel only.

1. Ensure that the gas valve knob is in the OFF position.
2. Remove the pressure tap plug from the gas valve (see arrows in photos below for location).

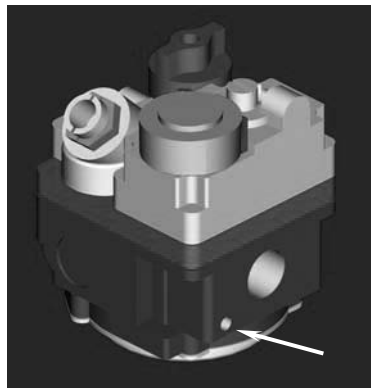

Pilot Ignition Valve
(Line Voltage)

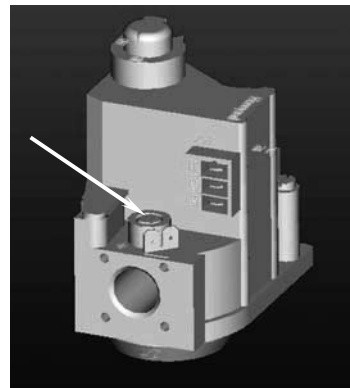

Electronic
Ignition Valve

3. Insert the manometer fitting into the pressure tap hole.
4. Place the gas valve in the ON position then place the fryer power switch in the ON position. When the burner lights and continues to burn, check the gas pressure reading against the table on page 1-1.
5. To adjust burner gas pressure, remove the cap from the gas valve regulator and adjust to correct pressure.
6. Place the fryer power switch and the gas valve in the OFF position. Remove the manometer fitting from the pressure tap hole and reinstall the pressure tap plug.

HIGH EFFICIENCY DECATHLON SERIES GAS FRYERS

CHAPTER 1: SERVICE PROCEDURES

1.5 Adjusting the Pilot Flame

1.5.1 Main Pilot

1. Remove the cap from the pilot adjustment screw hole on the gas valve.
2. Using a small, flat-tipped screwdriver, turn the pilot adjusting screw counterclockwise to increase length of flame or clockwise to decrease length of flame. Adjust to obtain a flame from 1 inch to 1½ inches long.
3. Reinstall the pilot adjustment screw cap.

1.5.2 Trailing Pilot

Unlike older Decathlon units, current production HD units do not have a trailing pilot adjustment.

1.6 Calibrating the Thermatron

1. Fill the frypot to the lower OIL-LEVEL line with cooking oil. If solid shortening is used, it must be melted before starting the calibration procedure.
2. Ensure the fryer ON/OFF switch is in the OFF position and light the pilot.
3. Place the fryer ON/OFF switch in the ON position. Set the potentiometer dial to 325°F (162°C).
4. Allow the oil to equalize at setpoint temperature. This is evident when the burners have cycled on and off several times.
5. Insert a thermometer or pyrometer into the frypot within 3 inches of the probe bulb. Ensure the tip of the thermometer/pyrometer does not touch the frypot burner tube.
6. If the temperature on the thermometer is higher or lower than 325°F (162°C), the knob is out of calibration.
7. Calibrate the knob by first loosening the setscrews and slowly turning the knob to match the temperature reading of the thermometer. Tighten the setscrews, ensuring the knob does not move on the shaft during tightening.
8. Allow burners to cycle on and off several times, then recheck oil temperature as described in Step 5. If the thermostat dial temperature matches the thermometer temperature, the thermostat is calibrated. If not, repeat Step 7.

HIGH EFFICIENCY DECATHLON SERIES GAS FRYERS

CHAPTER 1: SERVICE PROCEDURES

1.7 Replacing Fryer Components

1.7.1 Replacing the Controller

1. Disconnect the fryer from the electrical supply.
2. Unscrew the two controller panel screws. The controller panel is hinged at the bottom and will swing open from the top.

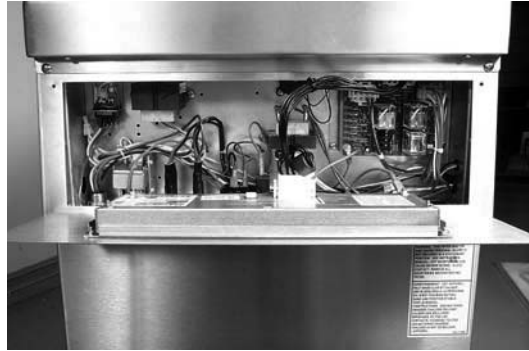

Computer panel in "down" position.

3. Unplug the fryer wiring harness and ground wire from the back of the controller.
4. Remove the controller by lifting it from the hinge slots in the fryer control panel frame.
5. Reverse the procedure to install a new controller.

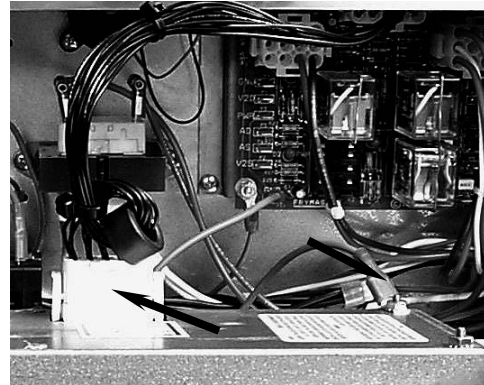

Disconnect the 15-pin connector and ground wire (arrows) from the computer.

HIGH EFFICIENCY DECATHLON SERIES GAS FRYERS

CHAPTER 1: SERVICE PROCEDURES

1.7.2 Replacing Control Box Components including Ignition Module, Interface Board, Transformers, etc.

1. Disconnect the fryer from the electrical supply.
2. Unscrew the two controller panel screws. The controller panel is hinged at the bottom and will swing open from the top.
3. Locate the component to replace.
4. Mark the location of the wires to facilitate easy reassembly.
5. Disconnect the wires.
6. Remove the screws attaching the component to the control box.
7. Reverse steps to complete the replacement and return the fryer to service.

HIGH EFFICIENCY DECATHLON SERIES GAS FRYERS

CHAPTER 1: SERVICE PROCEDURES

1.7.3 Replacing the Temperature Probe; Controller-equipped Fryers

1. Disconnect the fryer from the electrical supply.
2. Drain cooking oil from the frypot. Allow the frypot to cool completely before proceeding.
3. Remove fryer door for easier access to the temperature probe. First, remove top hinge from bracket. Then, lift door off bottom hinge pin.

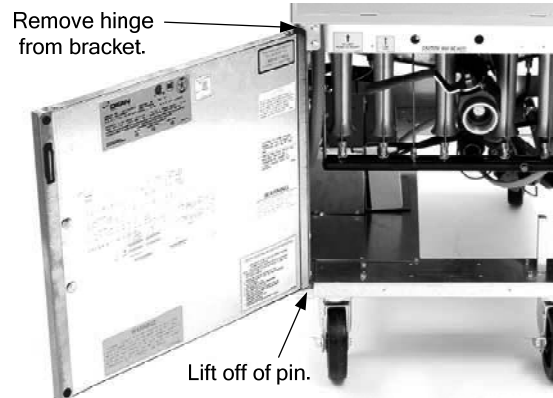

Remove the fryer door for easier access to the temperature probe.

4. Disconnect the probe harness connector (arrow). Use a pin pusher to remove plug from probe wires (probe side only). Retain the plug for re-assembly on new probe.

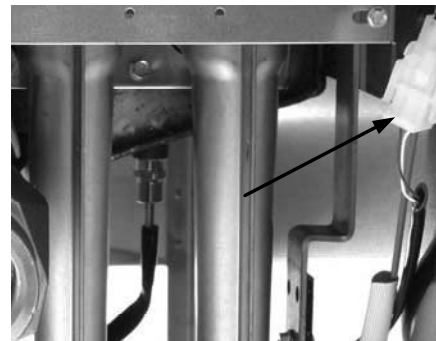

Disconnect the two-pin probe harness connector (arrow).

5. Remove the drain manifold. Only the drain tubes directly blocking the frypot being replaced require removal.

- Remove the nuts holding the drain valve strap onto the drain tube stud.
- Disconnect the Teflon tube at the back of the center dump tube piece and any other components attached to the tubes, including drain flush flexlines.
- Loosen the nut on each clamp holding the rubber boots and drain sections together.
- Carefully remove the tubes by pulling down at an angle, straight out of the drain valves, and working them gently out of the rubber boots. Set aside for reassembly.

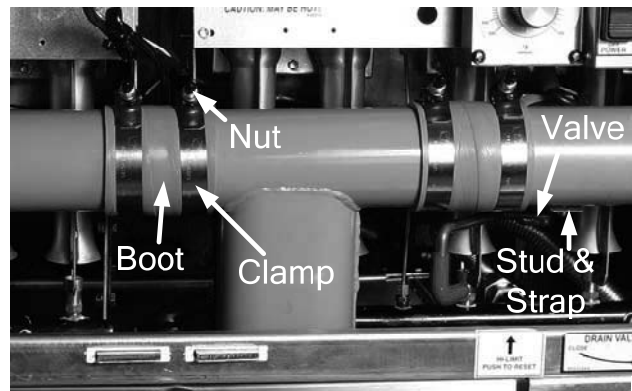

Remove the nuts, Teflon tube (not pictured), clamp, boot, and drain tubes.

HIGH EFFICIENCY DECATHLON SERIES GAS FRYERS

CHAPTER 1: SERVICE PROCEDURES

1.7.3 Replacing the Temperature Probe; Controller-equipped Fryers (cont.)

6. Remove the burner shield by loosening the screw on each end.
7. Remove the burner rail by loosening the screw on each end. The burner rail secures the burners in the burner manifold. Be careful to ensure that the burners do not fall out of the gas manifold, as they might be damaged and dented.

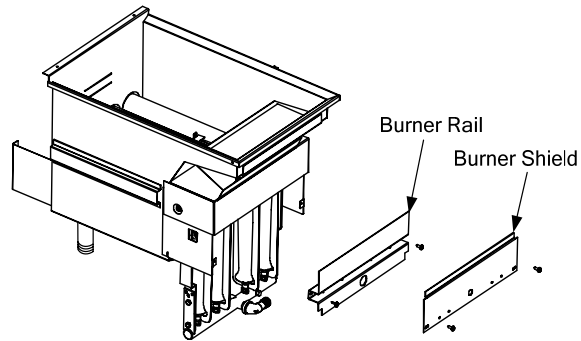

Remove the burner rail and burner shield.

8. Remove the burners to gain access to the temperature probe and to ease frypot removal. Lean each burner slightly away from the frypot to clear the burner seal (metal box attached to frypot). Then, pull the burner up and off of the orifice. The burners should be easy to remove and do not require force.

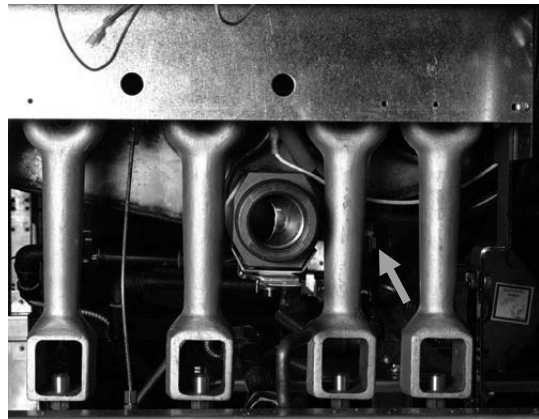

Remove burners to gain access to temperature probe (arrow).

9. Loosen and unscrew the compression nut and the pass-through nut completely from the frypot. Proceed to the next step before removing the probe from the frypot.

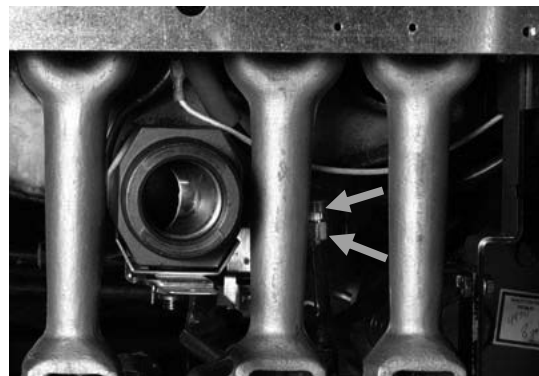

Loosen and unscrew completely the compression nut (bottom arrow), then the pass-through nut (top arrow).

HIGH EFFICIENCY DECATHLON SERIES GAS FRYERS

CHAPTER 1: SERVICE PROCEDURES

1.7.3 Replacing the Temperature Probe; Controller-equipped Fryers (cont.)

10. Locate the temperature probe inside the frypot.

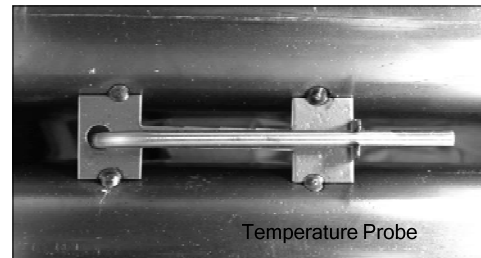
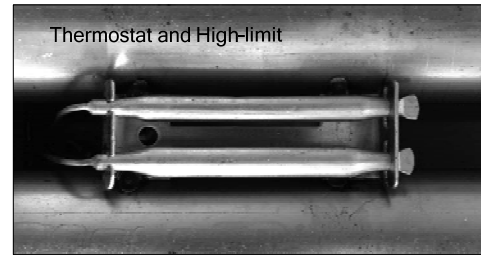

Locate the temperature probe.

11. The temperature probe can be removed through the bottom of the frypot as follows: Ensure the two-pin connector has been removed from the probe wiring harness (step 4, above). Carefully bend the two tabs (one forward and toward the back) so the probe will clear the tabs. Remove the harness insulation. The probe can be pulled through the frypot from the bottom (complete step 7, above, prior to removing probe).



12. Carefully remove the probe from the frypot. As the probe is removed, tilt the probe at an angle to facilitate removal (curved probes only).

After removing the probe mounting hardware, the temperature probe can be removed through the bottom of the frypot. Retain the mounting hardware for reassembly.

13. Follow the steps on the next page to install the new temperature probe.

IMPORTANT: When installing new probe, use Loctite PST567 or equivalent pipe thread sealant on threads and ensure probe is positioned properly with the mounting hardware installed prior to tightening the compression nut. **Once tightened, the probe cannot be repositioned.**

HIGH EFFICIENCY DECATHLON SERIES GAS FRYERS

CHAPTER 1: SERVICE PROCEDURES

Installing the New Temperature Probe:

1. Feed the probe wire through the probe nipple from the top side of the frypot.
2. Loosely install the bladder nut.
3. Mount the probe into the mounting hardware. Carefully bend the two tabs back into alignment to retain probe.
4. Tighten the bladder nut.
5. Install the insulation and plug.

1.7.4 Replacing the High-limit Thermostat

1. Turn fryer off and drain oil from the frypot. Allow the frypot to cool completely before proceeding.
2. Perform steps 1-4 in Section 1.7.1, *Replacing the Controller*.
3. Remove fryer door for easier access to the temperature probe. First, remove top hinge from bracket. Then, lift door off bottom hinge pin.
4. Remove two screws securing the high-limit mounting-bracket. Do not disconnect wires from high-limit at this time.

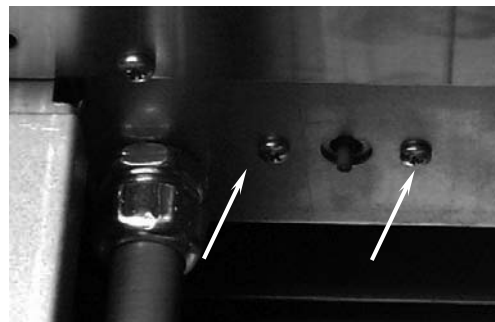

Remove screws (arrows) securing high-limit to fryer.

5. Loosen and completely unscrew the compression nut, then the pass-through nut on the frypot bottom. Proceed to the next step before removing high-limit from frypot.

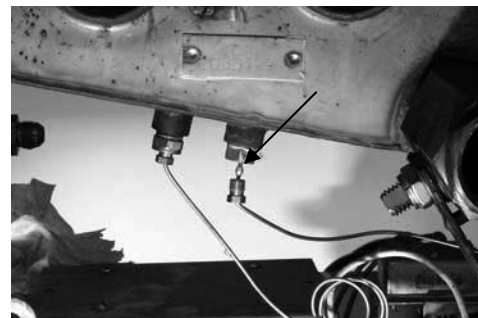

Compression nut unscrewed. Unscrew the pass-through nut (arrow).

HIGH EFFICIENCY DECATHLON SERIES GAS FRYERS

CHAPTER 1: SERVICE PROCEDURES

1.7.4 Replacing the High-limit Thermostat (cont.)

6. Locate the high-limit probe inside the frypot. Carefully bend the outer tab at the rear of the high limit until the high limit can slid back and out of the retaining bracket.

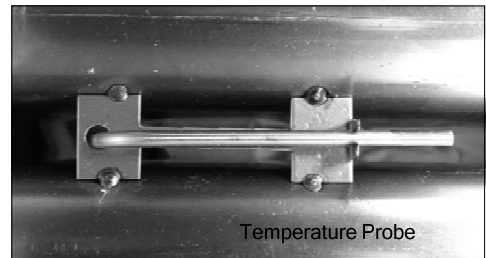
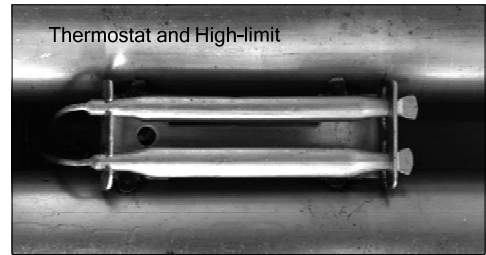

Locate the high-limit probe.

7. Carefully pull high-limit capillary tube and bulb out of the frypot from the bottom.

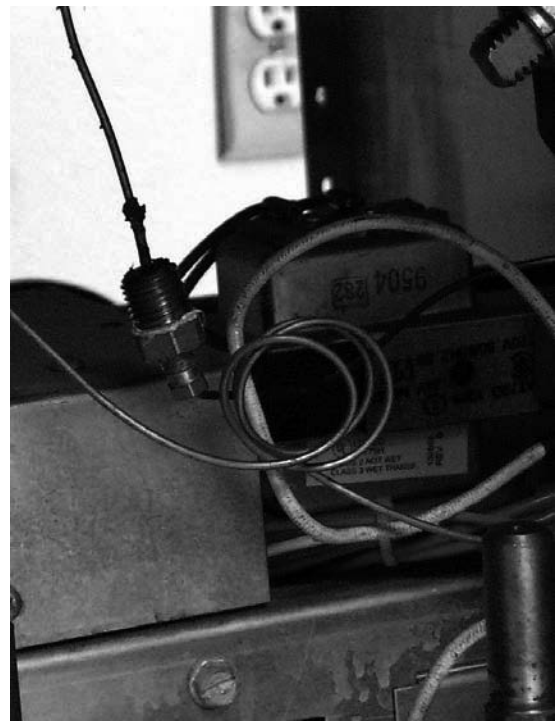

Remove high-limit capillary tube and bulb from the bottom of the frypot.

HIGH EFFICIENCY DECATHLON SERIES GAS FRYERS

CHAPTER 1: SERVICE PROCEDURES

1.7.4 Replacing the High-limit Thermostat (cont.)

8. Mark and disconnect wires at the high-limit in the component box.

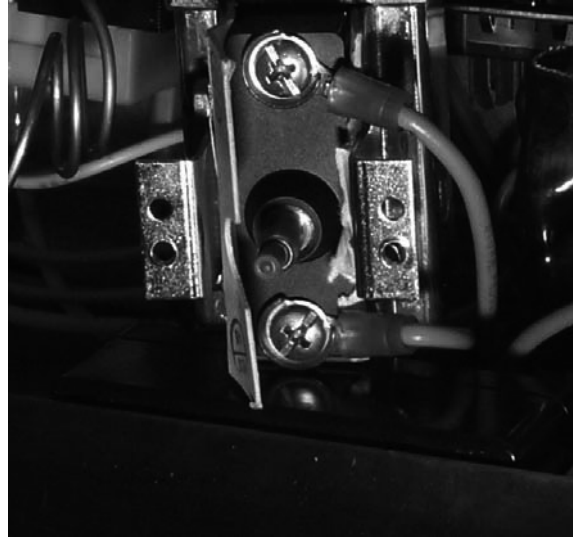

Mark and disconnect high-limit wiring (arrows). Reconnect wires to the same terminals on the replacement high-limit.

9. Remove high-limit from fryer by pulling the capillary tube and bulb through the component box opening (arrow). This may require removal of the control panel frame.



10. Reverse the above steps for high-limit installation.

IMPORTANT: When installing new high-limit, ensure the capillary tube and bulb are positioned properly with tab back in alignment prior to tightening the compression nut. **Once tightened, the capillary tube cannot be repositioned.**

Component box opening (arrow).

HIGH EFFICIENCY DECATHLON SERIES GAS FRYERS

CHAPTER 1: SERVICE PROCEDURES

1.7.5 Replacing Rocker Switches

1. Disconnect the fryer from the electrical supply.
2. **If switches are located in a control box within the fryer**, remove the six screws securing the switch panel to the control box. Do not allow the switch panel to hang from the switch wiring harness or other wires.



Remove the screws holding the plate in place, then depress the clips on each end to remove the switch.

HIGH EFFICIENCY DECATHLON SERIES GAS FRYERS

CHAPTER 1: SERVICE PROCEDURES

1.7.5 Replacing Rocker Switches (cont.)

3. Depress the retaining clips (see illustration below) and push the switch out of the slot. If there is a switch-guard present, retain it for installation of the replacement switch.

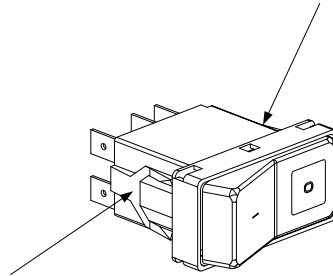

Depress clips on each side to remove switch from control panel.

4. Remove wires one at a time from the switch being removed and connect to the replacement switch until all wires are transferred.
5. Reverse the above steps for reassembly.

1.7.6 Replacing the Gas Valve



Drain the frypot or remove the handle from the drain valve before proceeding further.

1. Disconnect fryer from electrical and gas supplies.
2. Disconnect the wires from the gas valve terminal block, marking each wire to facilitate reconnections. For 120VAC gas valves, disconnect the black wire from the high-limit, then remove the bobtail connecting the white wire.
3. Remove the high-limit thermostat wire from the gas valve pilot coil (all but 120 VAC valves).
4. Remove the pilot gas line fitting from the gas valve.
5. Remove the pipe union collars to the left and right of the gas valve and remove the valve.
6. Remove the pipefitting from the old gas valve and install on the replacement valve, using Loctite PST567 or equivalent pipe thread sealant on threads. Do not apply sealant to the first two pipe threads. Doing so will clog and damage the gas valve.
7. Reverse steps 1-5 to install the replacement gas valve.

HIGH EFFICIENCY DECATHLON SERIES GAS FRYERS

CHAPTER 1: SERVICE PROCEDURES

1.7.7 Replacing the Pilot Assembly

1. Remove the pilot tubing from the bottom of the pilot assembly.
2. If the pilot is an electronic ignition pilot, disconnect the ignition cable and the sense wire.
3. Remove the pilot mounting screw(s) from the pilot mounting bracket and remove the pilot.
4. Reverse the procedure to replace the pilot assembly.

NOTE: The above procedure is applicable to standing pilot, electronic ignition, and trailing pilot assemblies.

1.7.8 Adjusting the Ignitor Assembly

1. Disconnect the fryer from the electrical supply.
2. Remove the outer cover plate by removing two screws as shown in Figure 1.
3. Remove the air shutter plate if applicable by removing the four screws in the four corners as shown in Figure 2.
4. Gently bend the ignitor spark probe until the gap distance is approximately 1/4" inch between the two points as shown in Figure 3.
5. Reverse steps to reassemble.

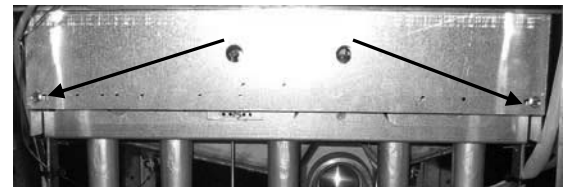

Figure 1

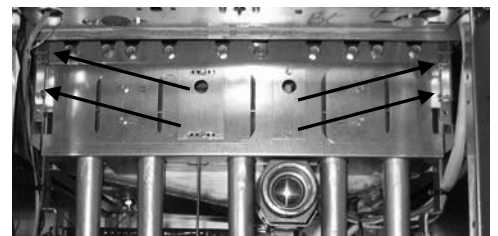

Figure 2

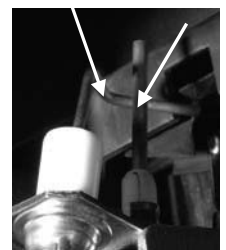

Figure 3

1.7.9 Replacing the Frypot

1. Open fryer doors and remove filter pan (if applicable). Ensure controller and all power switches are off. Drain and dispose of or store oil from all frypots prior to moving fryer.

⚠ DANGER

Hot cooking oil will cause severe burns. Never attempt to move this appliance when filled with hot cooking oil or to transfer hot cooking oil from one container to another.

2. Turn gas valve off, then turn gas off at supply valve or meter. Disconnect supply line from gas manifold at rear of fryer.

HIGH EFFICIENCY DECATHLON SERIES GAS FRYERS

CHAPTER 1: SERVICE PROCEDURES

NOTE: If restraints are installed on the fryer, disconnect restraints prior to disconnecting the gas supply line.

3. Unplug fryer from electrical supply source.
4. Remove fryer door for easier access to the temperature probe. First, remove top hinge from bracket. Then, lift door off bottom hinge pin.

5. Remove the basket hanger from the flue cap by lifting up and off of fryer. Some units may have a built-in flue deflector on the basket hanger. Units with basket lifts will require the removal of the lift arms prior to removing the basket hanger.



Removing the basket hanger from the flue cap.

6. Remove the top cap. It is held in place by one screw on each side of the fryer. If the fryer has a controller on the front, the top cap may also be held in place by two screws on the front of each pot. FPHD65 units may have two screws on each end of the top cap.



Removing the joiner strip.

7. Remove the joiner strips on either side of the frypot. Be careful not to bend the joiner strip during removal.

8. Remove back panels of the fryer. There may be both upper and lower panels and several screws secure them. Screw location and orientation will vary according to fryer model.



Typical screw locations on the back panel (may vary by model).

HIGH EFFICIENCY DECATHLON SERIES GAS FRYERS

CHAPTER 1: SERVICE PROCEDURES

1.7.9 Replacing the Frypot (cont.)

9. Remove screw securing brace (and back panel) to the flue cap. Support the brace with hand while removing screw to prevent brace from falling away. Remove brace and set aside for reassembly.

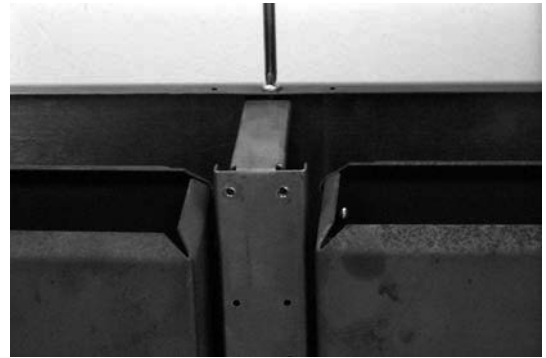

Removing brace holding back panel to flue cap.

10. Remove screws securing flue cap to frypot (access from above; a nut-driver with an extension or long screwdriver is required). Use care not to drop the screws into the flues. If this happens, the screws can be retrieved when the flue is removed (Step 12). Use a screwdriver or similar tool to free flue cap from frypots. Remove flue cap by lifting up and off of fryer.

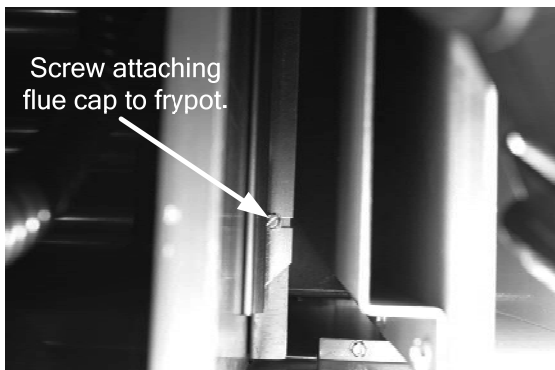

Remove the screws (arrow) securing the flue cap to the frypot on the long edge. There will be two or three screws depending on configuration. (view from above, looking down into flue)

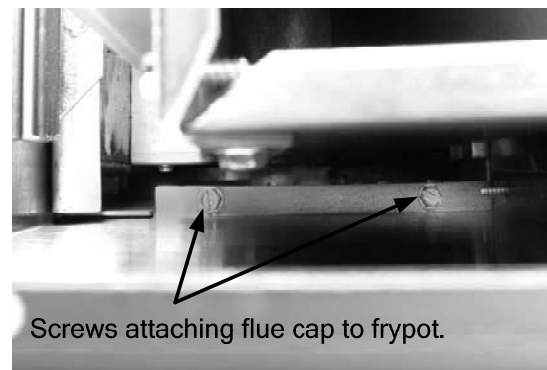

Remove the screws (arrows) securing the flue cap to the frypot on the short edge. There will be two screws on each end of the flue. (view from above, looking down into flue)

11. Remove gas manifold pipe for access to gas manifold shield by disconnecting at the unions. Ensure gas supply is shut off and supply line is disconnected prior to removing. Set gas manifold aside. Remove screws securing gas manifold shield. Remove shield to access oil-return plumbing components connected to the frypots.

NOTE: For units without built-in filtration skip the steps pertaining to removal and replacement of oil-return plumbing.



Removing gas manifold shield.

HIGH EFFICIENCY DECATHLON SERIES GAS FRYERS

CHAPTER 1: SERVICE PROCEDURES

1.7.9 Replacing the Frypot (cont.)

12. Remove screws securing flue to frypot (access from above; a nut-driver with an extension or long screwdriver is required). Retrieve any screws dropped into the flue during removal of the flue cap and frypot bracket.



Removing bolts (arrows) securing flue to frypot.

13. Remove the clevis clip and oil return handle rod from the oil return valve at the rear of the fryer. Slip Section A of the clevis clip off of the oil return handle by pulling up on the rings. Slide the oil return handle out of the bracket and Section B of the clevis clip. Repeat for the drain flush handle (if applicable).

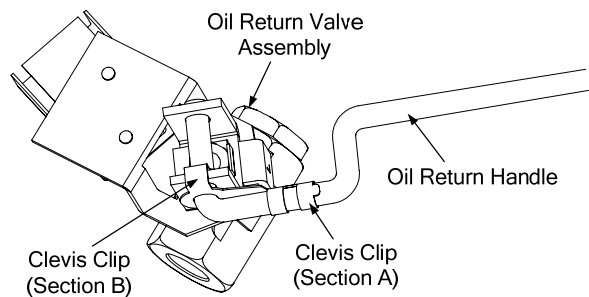

Disconnect oil-return handle from clevis clip and valve.

14. Loosen the two screws on the front of the oil return handle bracket at the front of the fryer. Remove the bracket and handle and set aside for reassembly. Repeat for the drain flush handle (if applicable).



Oil-return handle bracket and screws.

HIGH EFFICIENCY DECATHLON SERIES GAS FRYERS

CHAPTER 1: SERVICE PROCEDURES

1.7.9 Replacing the Frypot (cont.)

15. Remove the drain manifold. Only the drain tubes directly blocking the frypot being replaced require removal.

- Remove the nuts holding the drain valve strap onto the drain tube stud.
- Disconnect the Teflon tube at the back of the center dump tube piece and any other components attached to the tubes, including drain flush flexlines.
- Loosen the nut on each clamp holding the rubber boots and drain sections together.
- Carefully remove the tubes by pulling down at an angle, straight out of the drain valves, and working them gently out of the rubber boots. Set aside for reassembly.

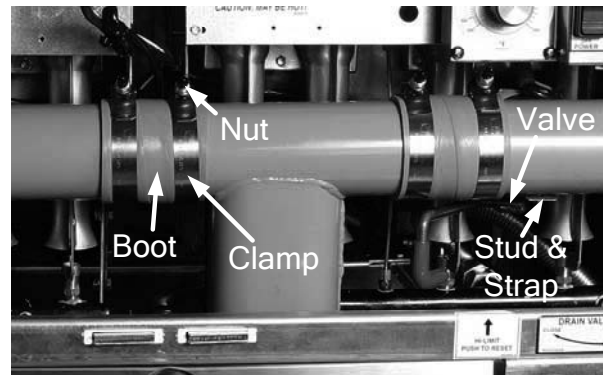

Drain manifold parts.

16. Remove the nipple attaching the oil return line to the bottom of the frypot at the rear of the fryer using a wrench. This may require removal of other pieces of the oil return manifold, as needed.

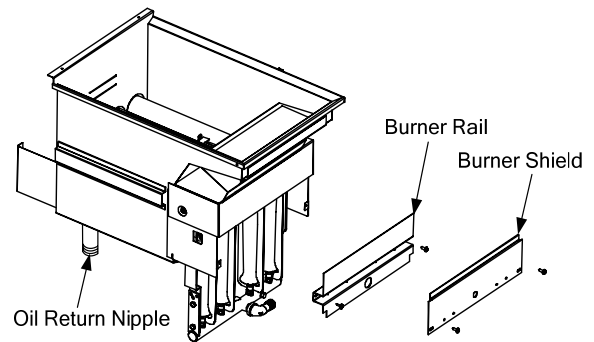

Oil-return nipple, burner shield, and burner rail.

17. Remove the burner shield by loosening the screw on each end.

18. Remove the burners to gain access to the temperature probe and to ease removal. Remove one burner at a time. Loosen the two screws attaching the burner to the burner rail. Slide the burner up until the heads of the two screws reach the round key holes and lean it slightly toward from the frypot to clear the burner rail and seal (metal box attached to frypot). Then, pull the burner up and off of the orifice. The burners should be easy to remove and do not require force.

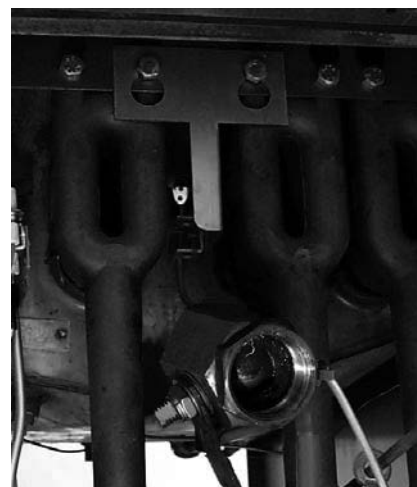

Remove drain valve handle and burners from fryer.

19. Remove the burner rail when all burners have been uninstalled. Loosen the screws on each end of the rail and set it aside.

HIGH EFFICIENCY DECATHLON SERIES GAS FRYERS

CHAPTER 1: SERVICE PROCEDURES

1.7.9 Replacing the Frypot (cont.)

20. If the fryer is equipped with drain-valve microswitches, mark the wires and microswitch terminals, then disconnect wires from the switch. Secure the wires to prevent damage when frypot is removed.

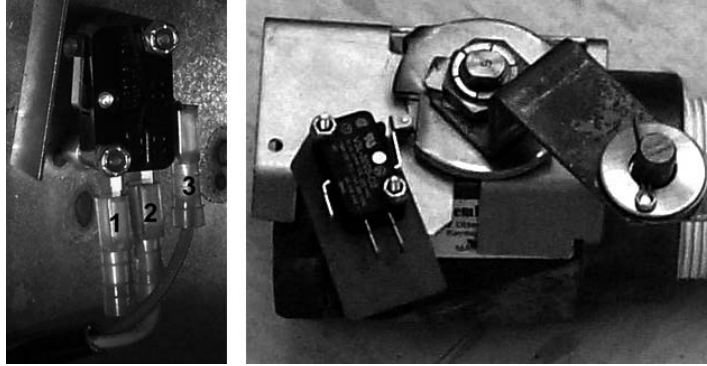

Left: Microswitch wires marked for removal (ensure microswitch terminals are marked the same as the wires removed). Right: Microswitch mounted to drain valve.

21. Remove the drain valve handle by loosening the drain valve nut and removing attached hardware. Depending on placement and configuration, the valve may be turned in a different direction than pictured.

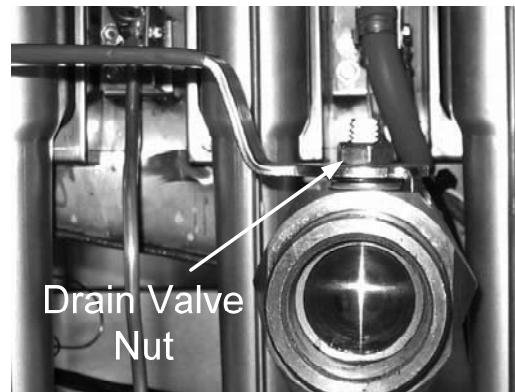

Remove the drain valve nut and attached hardware.

22. Remove the pilot assembly from the frypot.

- If trailing pilot, disconnect the pilot supply line from the trailing pilot valve on the burner manifold.

Remove the mounting screw(s) to detach the pilot assembly from the pilot bracket.

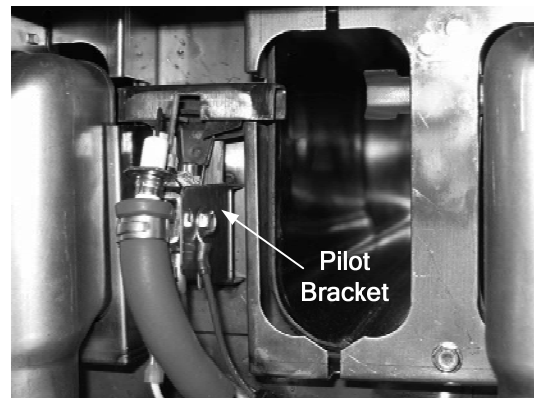

Remove the pilot assembly from the pilot bracket on the frypot.

HIGH EFFICIENCY DECATHLON SERIES GAS FRYERS

CHAPTER 1: SERVICE PROCEDURES

1.7.9 Replacing the Frypot (cont.)

23. Remove the temperature probe from frypot. (See Section 1.7.2, *Replacing the Temperature Probe: Controller-equipped Fryers*, for specific instructions.)
24. Remove the high-limit from the frypot (see Section 1.7.3, *Replacing the High-limit Thermostat*).
25. Remove bolts from brackets securing burner manifold to frypot. Leave the manifold in place.

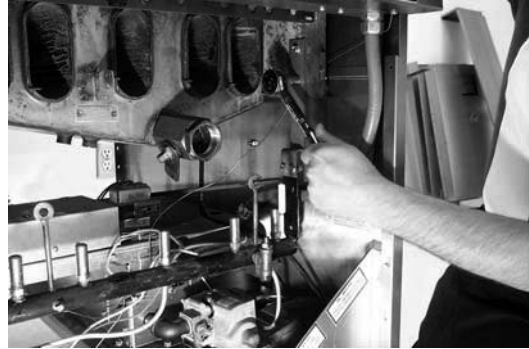

Removing bolts (arrows) from burner manifold support brackets (both sides). Leave the burner manifold in place after removing bolts.

26. Using a sharp knife or box-cutter, cut the silicon seal around the frypot. Use care not to scratch stainless steel surfaces.



Cutting frypot seal prior to frypot removal.

27. Ensure wires and tubes will not be caught on the frypot when it is removed.

28. Remove frypot from fryer by lifting up and out.



Lifting frypot from fryer.

HIGH EFFICIENCY DECATHLON SERIES GAS FRYERS

CHAPTER 1: SERVICE PROCEDURES

1.7.9 Replacing the Frypot (cont.)

29. Position the frypot upside down on a suitable work surface.

30. Record position of the valve stem in relation to the frypot prior to removing the drain valve. If equipped, remove microswitches and mounting hardware from valve prior to removal. Using a suitable wrench, remove the drain valve from the frypot. Use Loctite PST567 sealant when installing drain valve on replacement frypot.



Removing drain valve from frypot.

31. Remove all other hardware and accessories from the frypot.

32. Reverse the above steps to install the replacement frypot.

33. Add a bead of silicon around the edges of the new frypot, sealing the seam where the frypot and the cabinet meet. Only do this when the frypot is completely installed.

HIGH EFFICIENCY DECATHLON SERIES GAS FRYERS

CHAPTER 1: SERVICE PROCEDURES

1.8 Troubleshooting and Problem Isolation

Because it is not feasible to include every issue that might occur, this section is intended to provide technicians with a general knowledge of the broad problem categories associated with this equipment and the probable causes of each. With this knowledge, the technician should be able to isolate and correct any problem encountered.

You are likely to encounter problems in these broad categories:

1. ignition failure,
2. improper burner function,
3. improper temperature control,
4. improper controller function,
5. improper filtration function,
6. frypot leakage, and
7. basket lift malfunction.

The probable causes of each category are discussed in the following sections. Troubleshooting guides are included in Section 1.9 to assist in identifying some of the more common problems.

1.8.1 Ignition Failure

Ignition failure occurs when the ignition module fails to sense a flame within the 60-second time delay period and locks out. Turn the fryer off, locate and fix the problem, then turn fryer back on to clear the module lock.

There are three primary reasons for ignition failure, listed in order of probability:

1. The gas and electrical power supplies,
2. The electronic circuits, or
3. The gas valve.

The Gas and Electrical Power Supplies

The main indicators that the gas or electrical power supply is the cause of ignition failure are as follows: an entire battery of fryers fails to light, and/or there are no indicator lights illuminated on the fryer experiencing ignition failure. Verify that the quick disconnect hose is properly connected, the fryer is plugged in, the main gas supply valve is open, and the circuit breaker for the fryer electrical supply is not tripped.

HIGH EFFICIENCY DECATHLON SERIES GAS FRYERS

CHAPTER 1: SERVICE PROCEDURES

1.8.1 Ignition Failure (cont.)

The Electronic Circuits

If gas and electrical power are supplied to the fryer, the next most likely cause of ignition failure is a problem in the 24 VAC circuit of fryers equipped with electronic ignition systems, or in the pilot system for those without electronic ignition. If the fryer is equipped with a SUFF/UFF filtration system, verify that the drain valve is fully closed. (The valve is equipped with a microswitch that must be closed for power to reach the gas valve. The valve handle can appear to be closed when the microswitch is open.) If the valve is fully closed, or the fryer does not have a filtration system, refer to the troubleshooting guides in this chapter.

The Gas Valve

If the problem is not in the 24 VAC circuit or pilot system, it is most likely in the gas valve. Before replacing the gas valve, refer to the troubleshooting guides in this chapter.

1.8.2 Improper Burner Function

In these instances, the burner ignites but exhibits abnormal characteristics, such as *popping*, incomplete lighting of the burner, fluctuating flame intensity, and flames “rolling” out of the fryer.

Popping indicates delayed ignition. In most cases, the main gas valve is opening, but the burner is not immediately lighting. When ignition does take place, excess gas ignites rapidly rather than smoothly.

The primary causes of popping are:

1. low or fluctuating gas pressure,
2. misdirected or weak pilot flame,
3. clogged burner orifices,
4. clogged burners,
5. inadequate make-up air,
6. heat damage to the controller or ignition module,
7. an out-of-adjustment igniter or broken ignition wire,
8. a defective ignition module,
9. missing or misaligned burners,
10. clogged vent tube (causing incorrect gas pressure), or
11. make-up air is blowing down the flue.

HIGH EFFICIENCY DECATHLON SERIES GAS FRYERS

CHAPTER 1: SERVICE PROCEDURES

1.8.2 Improper Burner Function (cont.)

If popping occurs only during peak operating hours, the problem may be incorrect or fluctuating gas pressure. Verify that the incoming gas pressure (pressure to the gas valve) is in accordance with the appropriate requirements listed in the Installation and Operation manual that came with the fryer, and that the pressure remains constant throughout all hours of usage. Refer to *Adjusting Burner Manifold Pressure* in Section 1.4 if burner manifold pressure is suspected of being incorrect.

If popping is consistent during all hours of operation, verify that the pilot is properly positioned above the burner orifice and that the pilot pressure is correct. Correct pilot pressure is indicated by a flame 1 to 1½" long. Also verify that igniter is properly adjusted (electrode tip 1/8" from pilot hood corner). Refer to Section 1.5 for pilot adjustment procedure.

Clogged burners or burner orifices are also likely causes of delayed ignition. Clogged burners are indicated by uneven flame or partial flame on the burner face. Clogged orifices are indicated by no flame.

Another cause of popping is an insufficient air supply or drafts that are blowing the pilot flame away from the burner. Check for "negative pressure" conditions in the kitchen area. If air is flowing into the kitchen area, this indicates that more air is being exhausted than is being replenished and the burners may be starved for air.

If the fryer's gas and air supplies are okay, the problem most likely is with one of the electrical components. Examine the ignition module for signs of melting, distortion, or discoloration due to excessive heat build-up in the fryer. Also, examine the controller for the same conditions. This condition usually indicates improper flue performance. A melted or distorted ignition module is automatically suspect and should be replaced, but unless the condition causing excessive heat in the fryer is corrected, the problem is likely to recur.

Next, ensure the ignition wire is tightly connected at both ends and examine it for obvious signs of damage. Again, if damage is due to excessive heat in the fryer, that problem must also be corrected.

Check for proper operation by disconnecting the wire from the igniter, inserting the tip of a screwdriver into the terminal, and holding it near the frame of the fryer as the power switch is placed in the "ON" position. A strong, blue spark should be generated for at least 60 seconds.

<p> DANGER MAKE SURE YOU ARE HOLDING THE INSULATED HANDLE OF THE SCREWDRIVER AND NOT THE BLADE. THE SPARKING CHARGE IS APPROXIMATELY 25,000 VOLTS.</p>

Ensure the gap setting of the igniter is correct (electrode tip 1/8" from pilot hood corner).

HIGH EFFICIENCY DECATHLON SERIES GAS FRYERS

CHAPTER 1: SERVICE PROCEDURES

1.8.2 Improper Burner Function (cont.)

Burners lighting on the left side only may be caused by a trailing pilot problem (four- and five-tube frypots) or improper burner manifold pressure.

Fluctuating flame intensity is normally caused by either improper or fluctuating incoming gas pressure, but may also be the result of variations in the kitchen atmosphere. Verify incoming gas pressure in the same way as for "popping," discussed in the preceding paragraphs. Variations in the kitchen atmosphere are usually caused by air conditioning and/or ventilation systems starting and stopping during the day. As air conditioning/ventilation systems start and stop, the pressure in the kitchen may change from positive or neutral to negative, or vice versa. Changes in airflow patterns may affect flame intensity.

Flames "rolling" out of the fryer are usually an indication of negative pressure in the kitchen and make up air blowing down the flue. Air is being sucked out of the fryer enclosure and the flames are literally following the air. If negative pressure is not the cause, check for high burner-manifold gas pressure in accordance with the procedures in Section 1.4. An obstructed flue, which prevents the fryer from properly exhausting, may also be the cause.

Excessively noisy burners may indicate that the burner gas pressure is too low, the tube diffusers are defective or burned out, or it may simply be that the gas valve vent-tube is blocked (if applicable). If the gas pressure is correct, the tube diffusers are intact and in good condition, and the vent-tube is unobstructed (if applicable), the gas valve regulator is probably defective.

1.8.3 Improper Temperature Control

Temperature control is a function of several interrelated components, including the melt cycle. Each must operate correctly. The principal component is the temperature probe. Depending upon the specific configuration of the fryer, other components may include the interface board, the controller/controller itself, and the ignition module.

Improper temperature control problems can be categorized into melt cycle problems and failure to control at setpoint.

In fryers equipped with a Thermatron, the problem will be with the thermostat. Possible causes are that the thermostat is out of calibration or defective. Refer to Section 1.6 for instructions on calibrating the thermostat.

In fryers equipped with controllers, the problem may be with the temperature probe, the interface board, or the controller. Refer to the troubleshooting guides in this chapter.

HIGH EFFICIENCY DECATHLON SERIES GAS FRYERS

CHAPTER 1: SERVICE PROCEDURES

1.8.4 Improper Controller Function

Sensitivity or "Stretch Time." Sensitivity—or stretch time—is a programmable feature that increases the cook time countdown based on variations in the oil temperature from the setpoint (e.g., when cold product is dropped into the oil, causing the oil temperature to drop).

The sensitivity for each product button has 10 settings (0 through 9). A "0" sensitivity setting will disable the feature (no change in cooking time), while a nine will provide the highest sensitivity or the most change. The correct sensitivity for any product is based on the product type, its density, the setpoint temperature, and the customer's own requirements.

Common Controller Complaints. Most problems concerning controllers have to do with programming them. There are four common complaints. The complaints, their causes, and corrective actions are as follows for the Dean Compu-Fry controller:

1. Fryer constantly displays "**HI**".

Cause: Setpoint incorrect or missing.

Corrective Action: Press 1 6 5 0, enter the correct setpoint using keypad, then press and then this to lock in the setpoint.

2. Temperature is displayed in Celsius.

Cause: Controller is programmed to display in Celsius.

Corrective Action: Press 1 6 5 8.

3. Temperature is constantly displayed.

Cause: Controller is programmed for constant temperature display.

Corrective Action: Press 1 6 5 L.

4. Controller times down too slowly or too quickly.

Cause: Controller is compensating for oil temperature via the sensitivity setting.

Corrective Action: Reprogram sensitivity setting for each product in accordance with programming instructions in the Compu-Fry Operation and Programming manual, P/N 819-5865.

HIGH EFFICIENCY DECATHLON SERIES GAS FRYERS

CHAPTER 1: SERVICE PROCEDURES

1.8.5 Improper Filtration Function

The majority of filtration problems arise from operator error. One of the most common errors is placing the filter paper on the bottom of the filter pan rather than over the filter screen. Anytime the pump is running, but no oil is being filtered, check the installation and size of the filter paper. Verify that the O-rings on the slip-connection are in good condition. Missing or worn O-rings allow the pump to suck air, decreasing its efficiency.

If the pump motor overheats, the thermal overload will trip and the motor will not start until it is reset. If the pump motor does not start, press the red reset switch located on the rear of the motor. Also, reset the filter circuit breaker located under the fryer control panel. If the pump then starts, something caused the motor to overheat. The pump most likely overheated for one of the following reasons:

- Shortening was solidified in the pan or filter lines.
- Multiple frypots were filtered one-after-another. Allow the pump to cool for 30 minutes before using again.
- The operator attempted to filter unheated oil. Cold oil is thick and will cause the pump motor to work harder and overheat.

If the motor runs, but the pump does not, the pump is blocked. Incorrectly sized or installed paper allows food particles and sediment to pass through the filter pan and into the pump. When sediment enters the pump, the gears bind and cause the motor to overheat, tripping the thermal overload. Solidified shortening in the pump will produce the same result. A pump seized by debris or hard shortening must be disassembled, cleaned, and reassembled in the following manner:

1. Disconnect power to the filter system.
2. Remove the front cover of the pump to access the gears inside, if the pump is accessible while still inside the cabinet. If the front cover is not accessible, the pump must be removed from the pump motor (disconnect input/output plumbing from the pump prior to removing it). Remove three setscrews to disengage the pump from the motor.
3. Prior to reassembly, the inside housing must be clean and free of any sediment or debris. If not, the gears will bind again after reassembly.

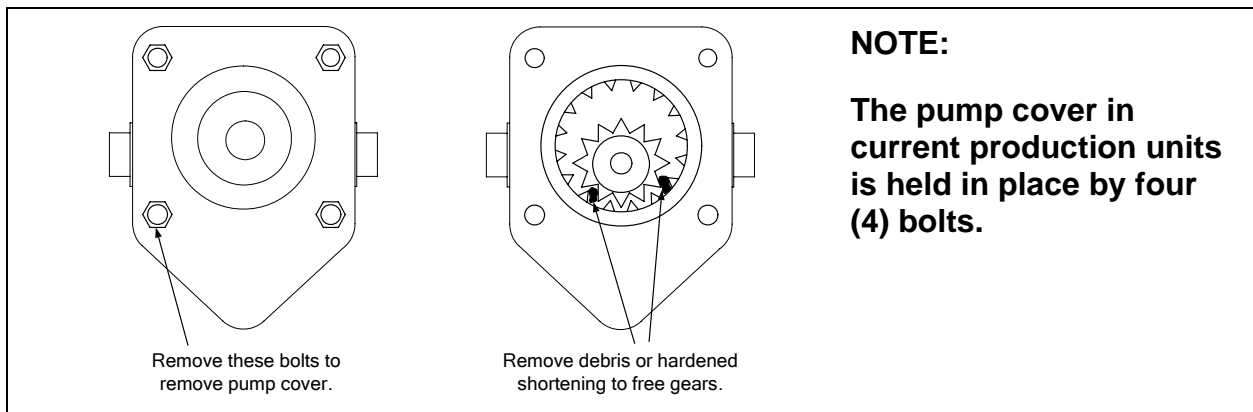

HIGH EFFICIENCY DECATHLON SERIES GAS FRYERS

CHAPTER 1: SERVICE PROCEDURES

1.8.5 Improper Filtration Function (cont.)

Incorrectly sized or installed paper will allow food particles and sediment to pass through and clog the suction tube on the bottom of the filter carriage. Particles large enough to block the suction tube may indicate that the crumb tray is not being used.

Pan blockage can also occur if shortening is left in the pan and allowed to solidify. Heater strips (if equipped) on the oil return plumbing are designed to prevent solidification of shortening left in the plumbing. Heater strips will not melt or prevent solidification of shortening in the pan.

Remove blockage by forcing it out with an auger or drain snake. DO NOT use compressed air or other pressurized gases to force out the blockage.

The SUFF/UFF filtration systems use microswitches attached to handles for each vat. They are wired in parallel and provide the 24 VAC required to activate the pump relay coil when the handles are moved to the ON position. The activated pump relay coil pulls the pump motor switch in, supplying power to the pump motor.

Filter systems equipped with oil-return heater tape are wired into the 120 VAC source, and remain energized as long as the unit is plugged in and power remains constant. Heater tape should receive constant power all day and all night; it should not be connected to a power supply that is turned off at night.

1.8.6 Frypot Leakage

Frypot leaks are almost always due to improperly sealed high-limit, thermostats/temperature probe and drain fittings. When installed or replaced, each of these components must be sealed with Loctite PST567 sealant or equivalent to prevent leakage. In very rare cases, a leak may develop along one of the welded edges of the frypot, or where the tube is welded to the frypot. When this occurs, the frypot must be replaced.

If the sides or ends of the frypot are coated with oil, the most likely cause is spillage over the top of the frypot rather than leakage.

Frypot locations (indicated by arrows)
where potential leaks could occur.

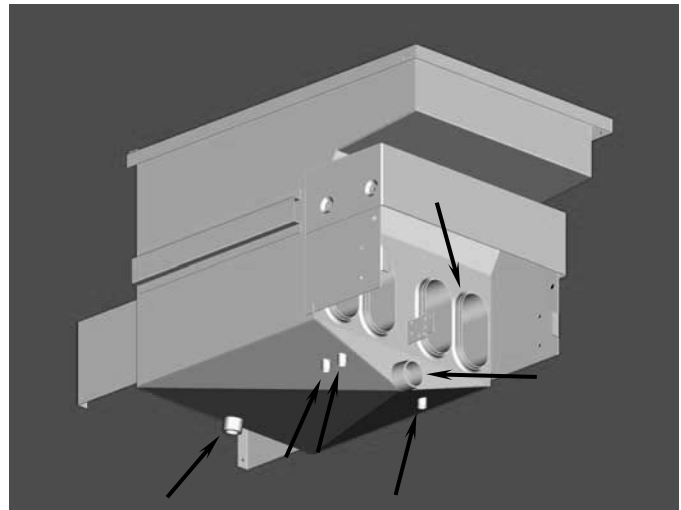

HIGH EFFICIENCY DECATHLON SERIES GAS FRYERS

CHAPTER 1: SERVICE PROCEDURES

1.8.7 Improper Basket Lift Function

Bell-Crank Basket Lifts

Most High Efficiency Decathlon Series gas fryers are equipped with a **bell-crank style basket lift**. A cam and a bell crank are connected to the basket lift arm by a flat metal link. The cam is attached to a drive motor. The motor rotates the cam, raising or lowering the lift arm linked to the bell crank. A roller-activated microswitch is used to limit travel. When the roller in the microswitch is in contact with the cam, the motor is energized. As the cam rotates, the roller loses contact with the cam and the motor power circuit is broken, de-energizing the motor.

Timing circuitry in the controller initiates and stops basket lift operation. When the product button is pressed, the timing circuitry activates a coil in the basket lift relay to supply power to the motor. The microswitch stops the motor at the lift's lower travel limit and the switch contacts are reversed. At the end of the programmed cooking time, the timing circuit activates the coil once more and the lift rises until the microswitch again loses contact with the cam, opening the motor power circuit and stopping the motor.

Problems with the bell-crank basket lift system can be grouped into two categories:

- binds and jams or
- motor and gear wear.

Binds and jams. Noisy, jerky, or erratic lift movement is usually due to lack of lubrication. Apply a light coat of Lubriplate or similar lightweight white grease to the connection points to correct the problem.

Motor Problems. If power is reaching the motor but the motor fails to run, the motor is burned out and must be replaced.

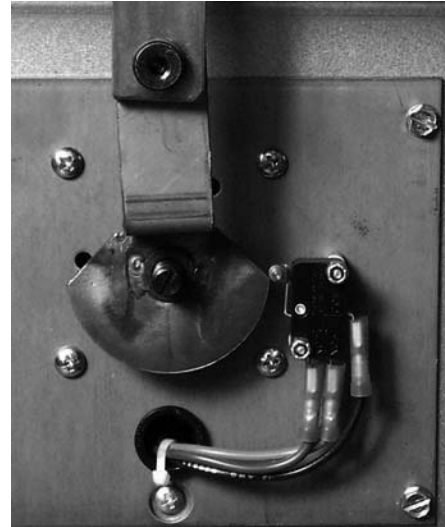

Back view of bell-crank basket lift.



Bell-crank basket-lift arms.

HIGH EFFICIENCY DECATHLON SERIES GAS FRYERS
CHAPTER 1: SERVICE PROCEDURES

1.9 Troubleshooting Guides

The following troubleshooting guides are intended to assist service technicians in quickly isolating the probable causes of equipment malfunctions by following a logical, step-by-step process.

PROBLEM	PROBABLE CAUSES	CORRECTIVE ACTION
Burner will not ignite. Light in ON/OFF switch is not illuminated.	A. ON/OFF switch is off.	A. Turn ON/OFF switch on.
ON/OFF switch is on, but the switch light is not illuminated.	A. No voltage at switch.	A. Ensure line voltage is present at the switch.
ON/OFF switch is on and the switch light is illuminated, but there is no output to gas valve.	A. Drain microswitch circuit (filter-equipped units) is open.	A. Ensure drain valve is fully closed and microswitch is functioning. Replace microswitch if defective.
	B. Voltage is present at ON/OFF switch, but continuity of the switch in ON position is not "0."	B. ON/OFF switch is defective. Replace switch with a known working switch.
	C. Continuity of thermostat is not "0" (oil temperature is at least 15°F below electronic thermostat setting).	C. Thermostat(s) is/are defective. Replace defective thermostat with a known working thermostat.
	D. Gas valve is suspect.	D. Go to "No burner flame" section.
No burner flame.	C. Gas valve is known to be good, but there is not 24 VAC (120VAC on systems so equipped) at the gas valve terminals.	D. Inspect electronic sensor (while still in frypot) for damage. Replace if bent, dented, or cracked. Inspect leads for fraying, burning, breaks, and/or kinks. If found, remove and replace thermostat(s). Remove leads from terminal block, allow oil to cool 15°F (8°C) below thermostat setting, and check continuity. If continuity is not "0," then thermostat has failed. Replace thermostat(s).
Fluctuating or erratic lighting of burner flame.	A. Incoming gas supply pressures are not within range [Natural- 6-14" W.C. (1.49-3.49 kPa); Propane- 11-14" W.C. (2.74-3.49 kPa)]	A. Inspect gas supply to fryer. Repair and/or replace faulty components (defective supply shut-off valves, incorrect piping size, etc.)
	B. Air in gas supply lines (new installation).	B. Allow unit to cycle on and off for approximately 30 minutes to force air from gas manifold and lines.
Electronic/operating thermostat will not adjust to correct temperature.	A. Electronic/operating thermostat is out of calibration.	A. Calibrate electronic/operating thermostat. Replace if calibration is not possible.

HIGH EFFICIENCY DECATHLON SERIES GAS FRYERS

CHAPTER 1: SERVICE PROCEDURES

1.10 Wiring Diagrams

Note: The diagrams in this section depict wiring as of the date of manual publication. It may not reflect design changes made to the equipment after publication. Refer to the wiring diagram affixed to the unit when actually troubleshooting this equipment.

1.10.1 Controller Dean Common Cabinet

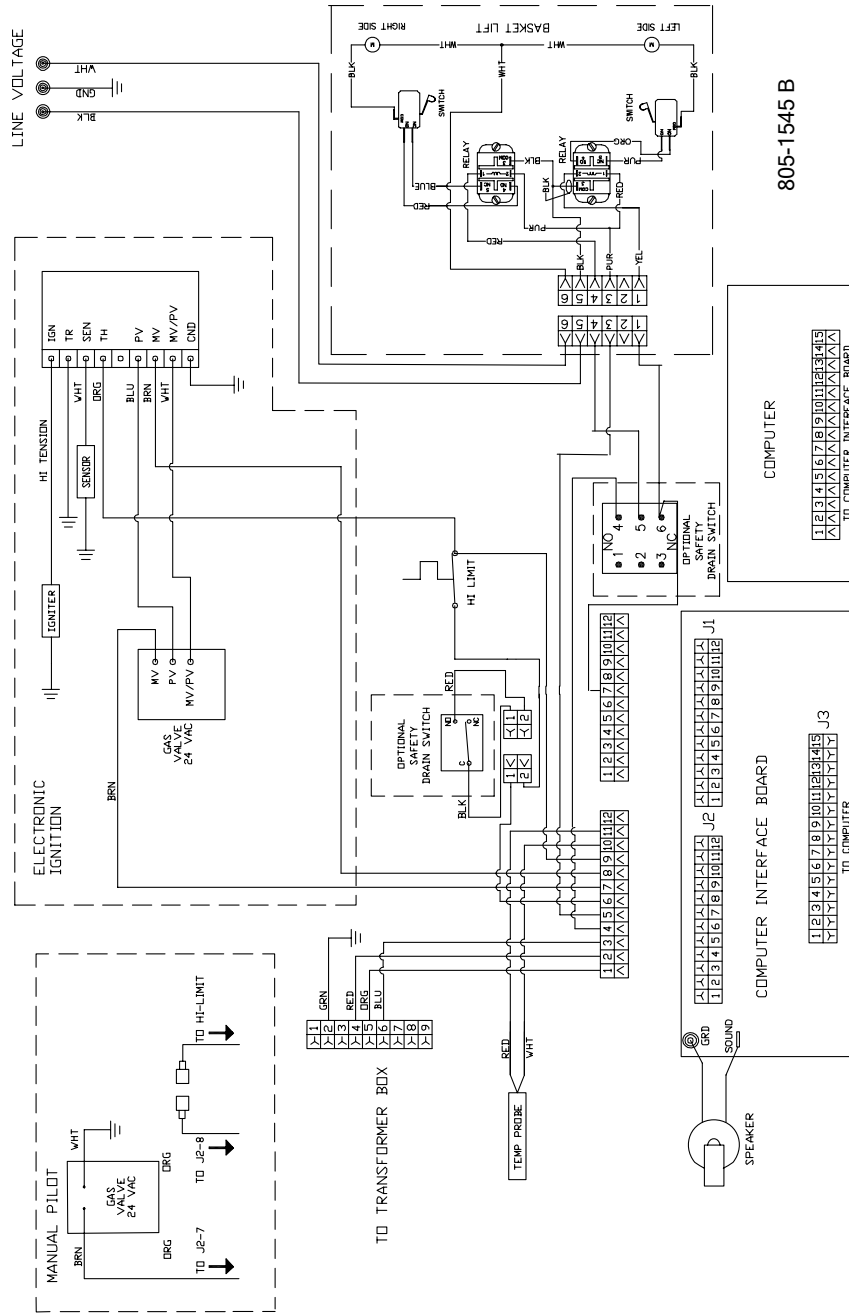

HIGH EFFICIENCY DECATHLON SERIES GAS FRYERS

CHAPTER 1: SERVICE PROCEDURES

1.10.2 Wingstreet Common Cabinet

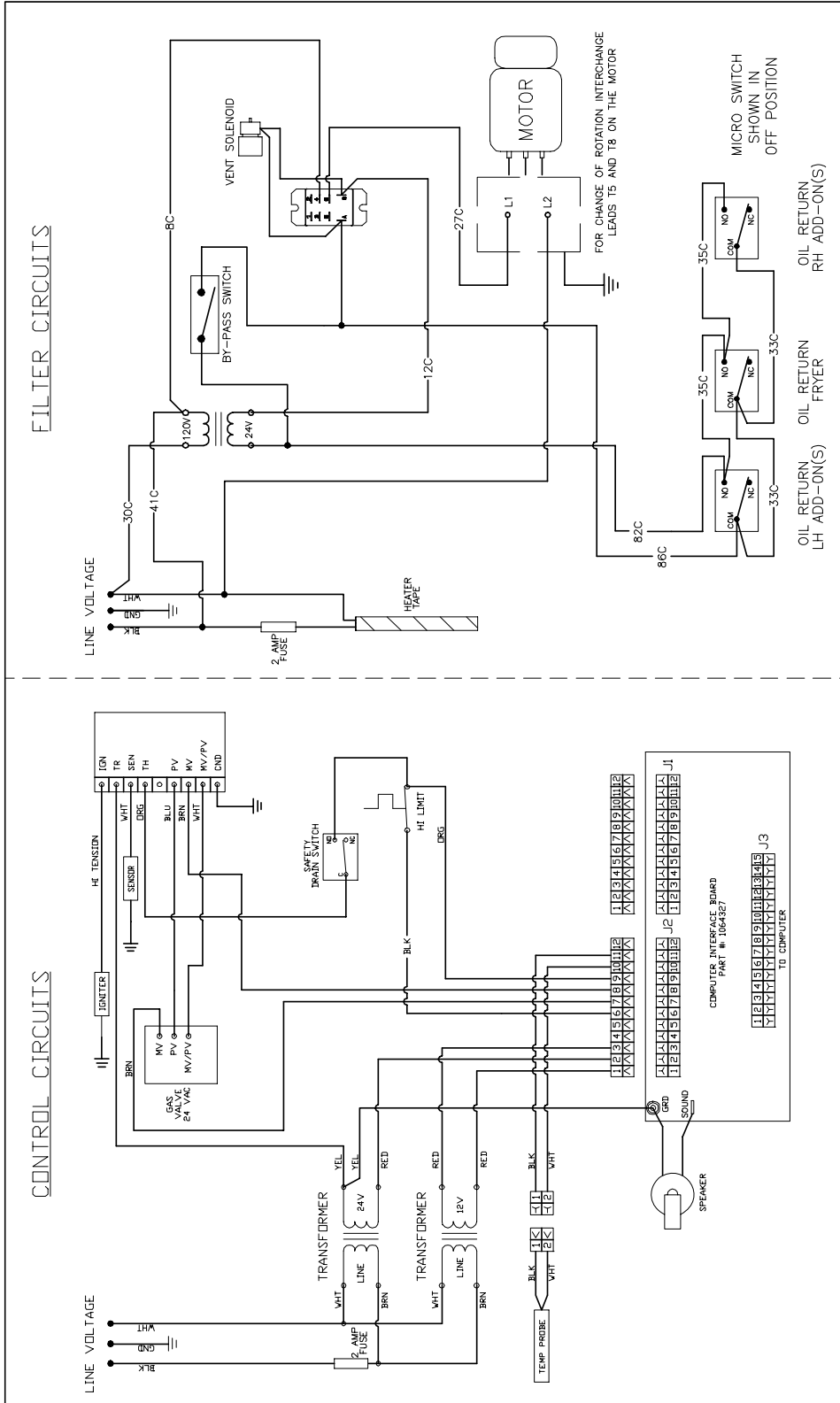

805-1599 B

HIGH EFFICIENCY DECATHLON SERIES GAS FRYERS

CHAPTER 1: SERVICE PROCEDURES

1.10.3 BK1814 Main Wiring Diagram prior after Sep. 2010

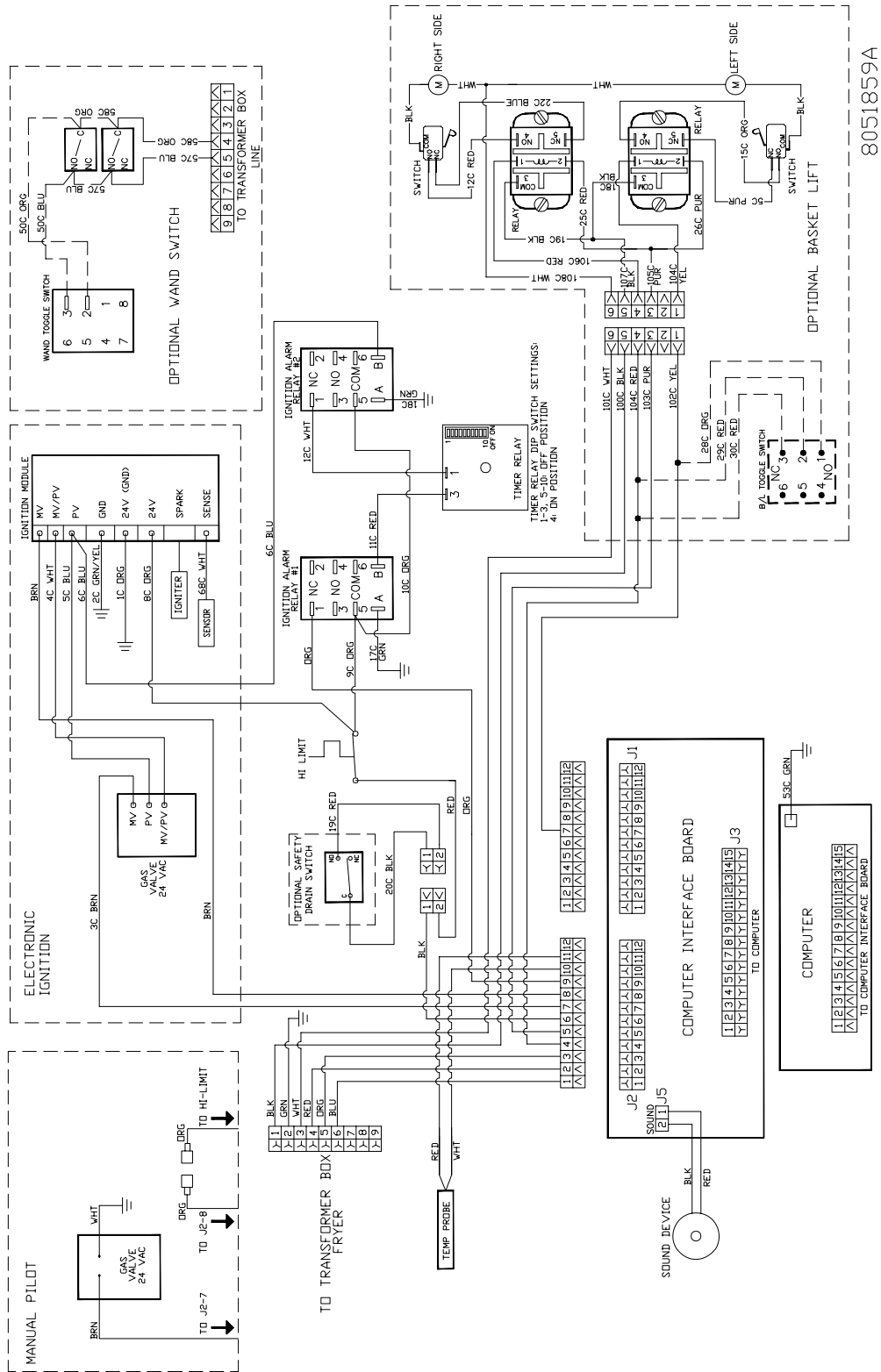

HIGH EFFICIENCY DECATHLON SERIES GAS FRYERS

CHAPTER 1: SERVICE PROCEDURES

1.10.4 BK1814 Main Wiring Diagram prior to Sep. 2010

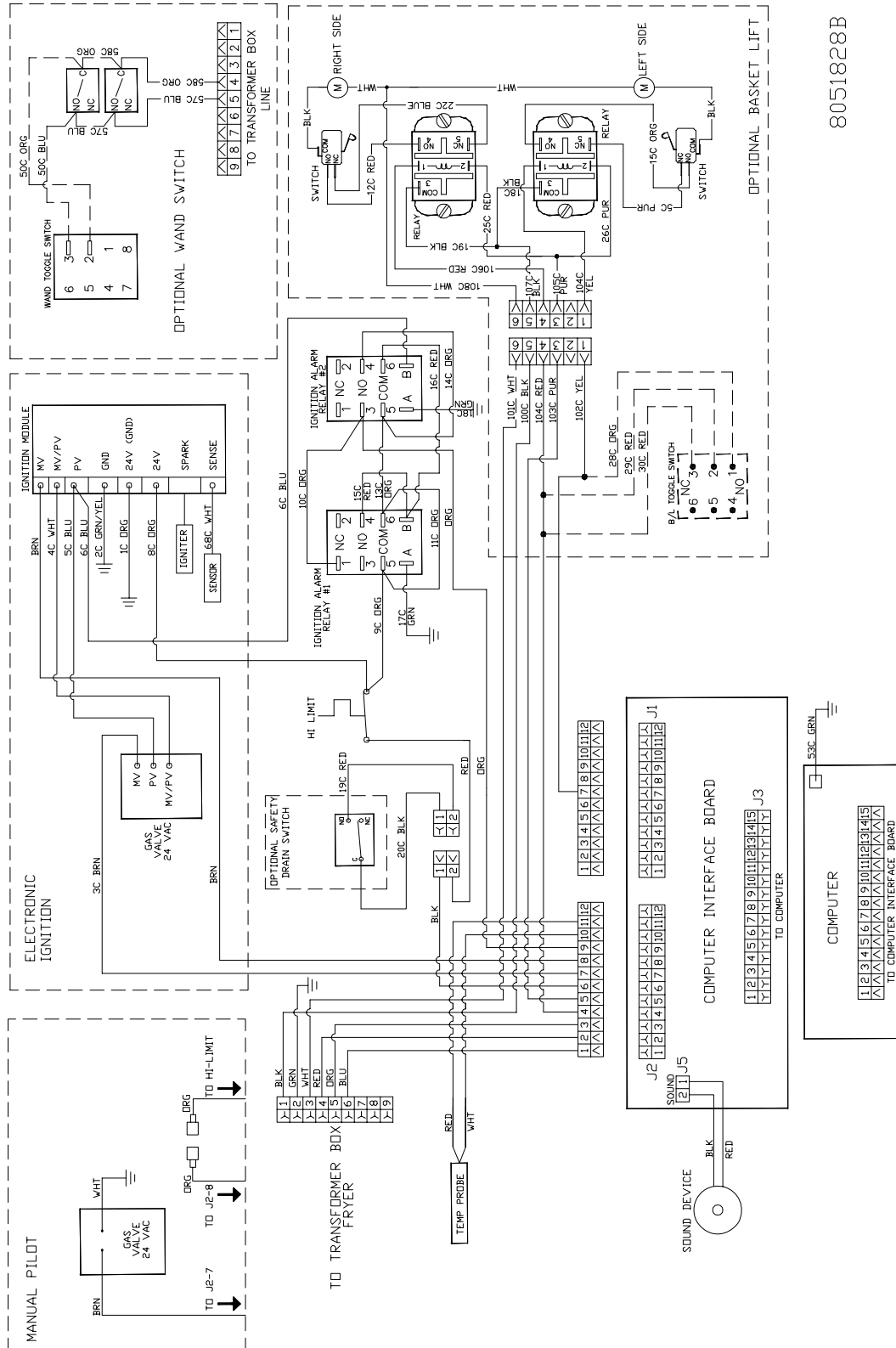

HIGH EFFICIENCY DECATHLON SERIES GAS FRYERS
CHAPTER 1: SERVICE PROCEDURES

1.10.5 BK1814 RAM Wiring Diagram

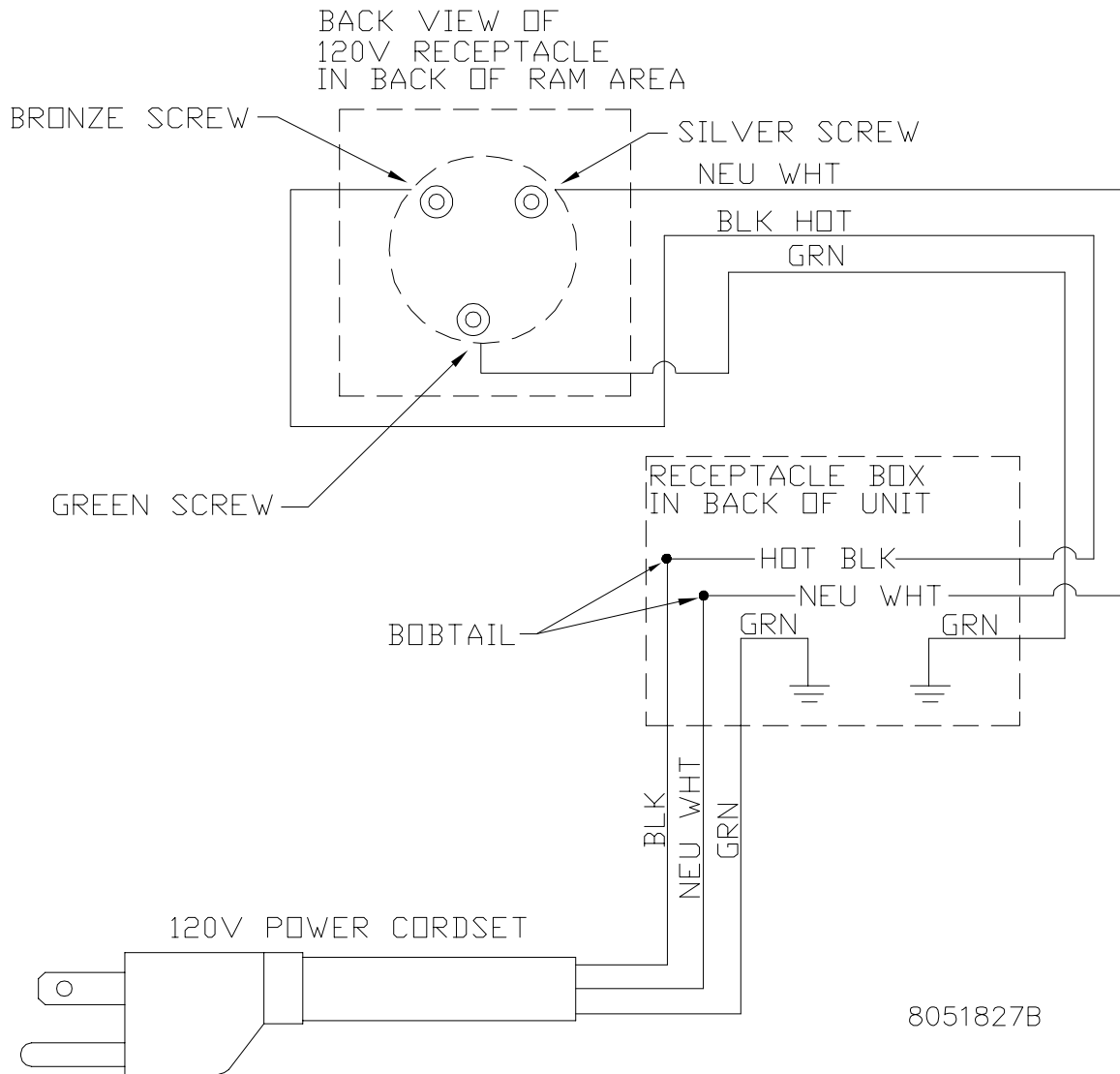

HIGH EFFICIENCY DECATHLON SERIES GAS FRYERS

CHAPTER 1: SERVICE PROCEDURES

1.10.6 Filter Box

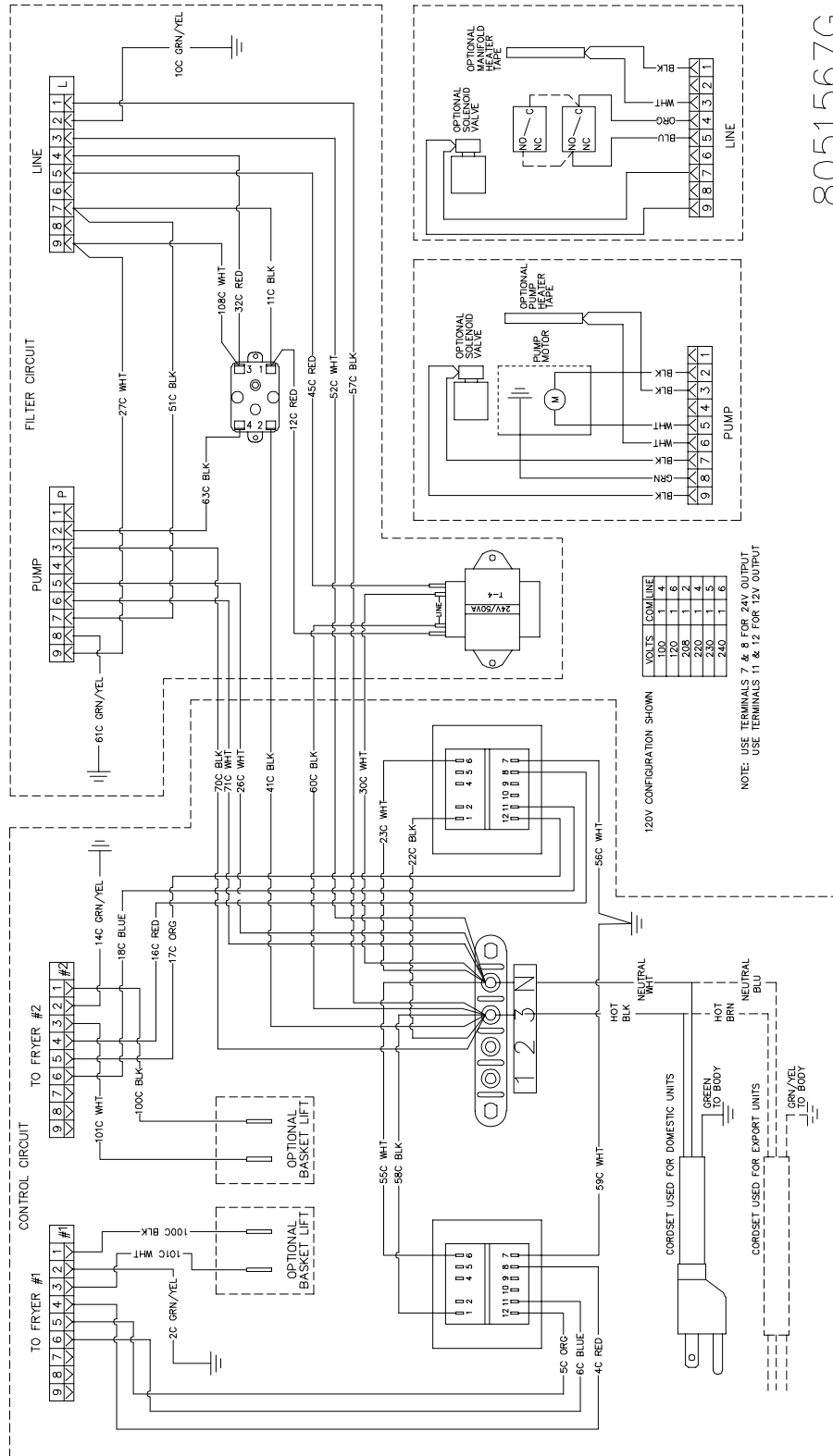

8051567G

HIGH EFFICIENCY DECATHLON SERIES GAS FRYERS

CHAPTER 1: SERVICE PROCEDURES

1.10.7 Thermatron Controller

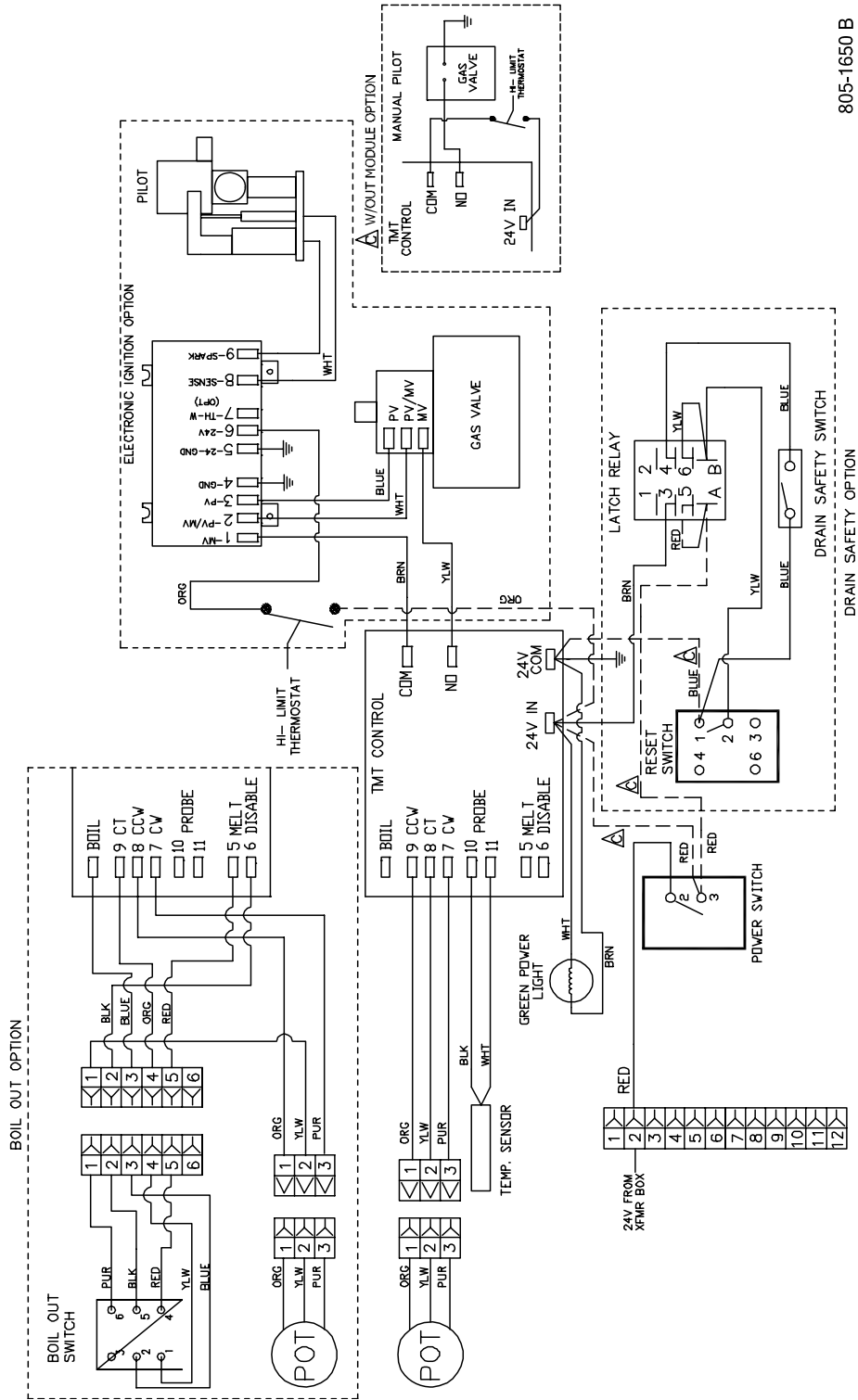

805-1650 B

HIGH EFFICIENCY DECATHLON SERIES GAS FRYERS

CHAPTER 1: SERVICE PROCEDURES

1.10.8 FAST Controller prior to Feb 09

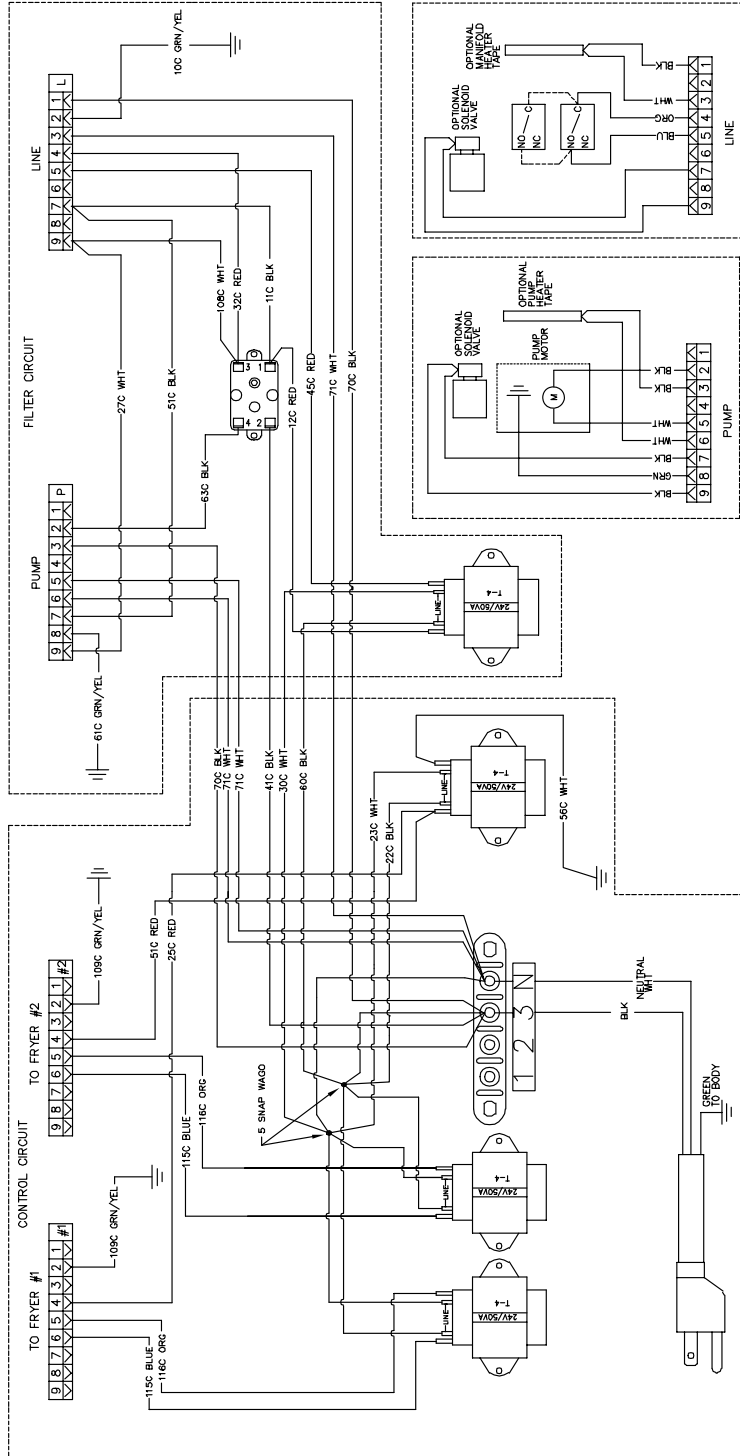

805-1689 C

HIGH EFFICIENCY DECATHLON SERIES GAS FRYERS

CHAPTER 1: SERVICE PROCEDURES

1.10.9 FAST Controller Non-CE after Feb 09

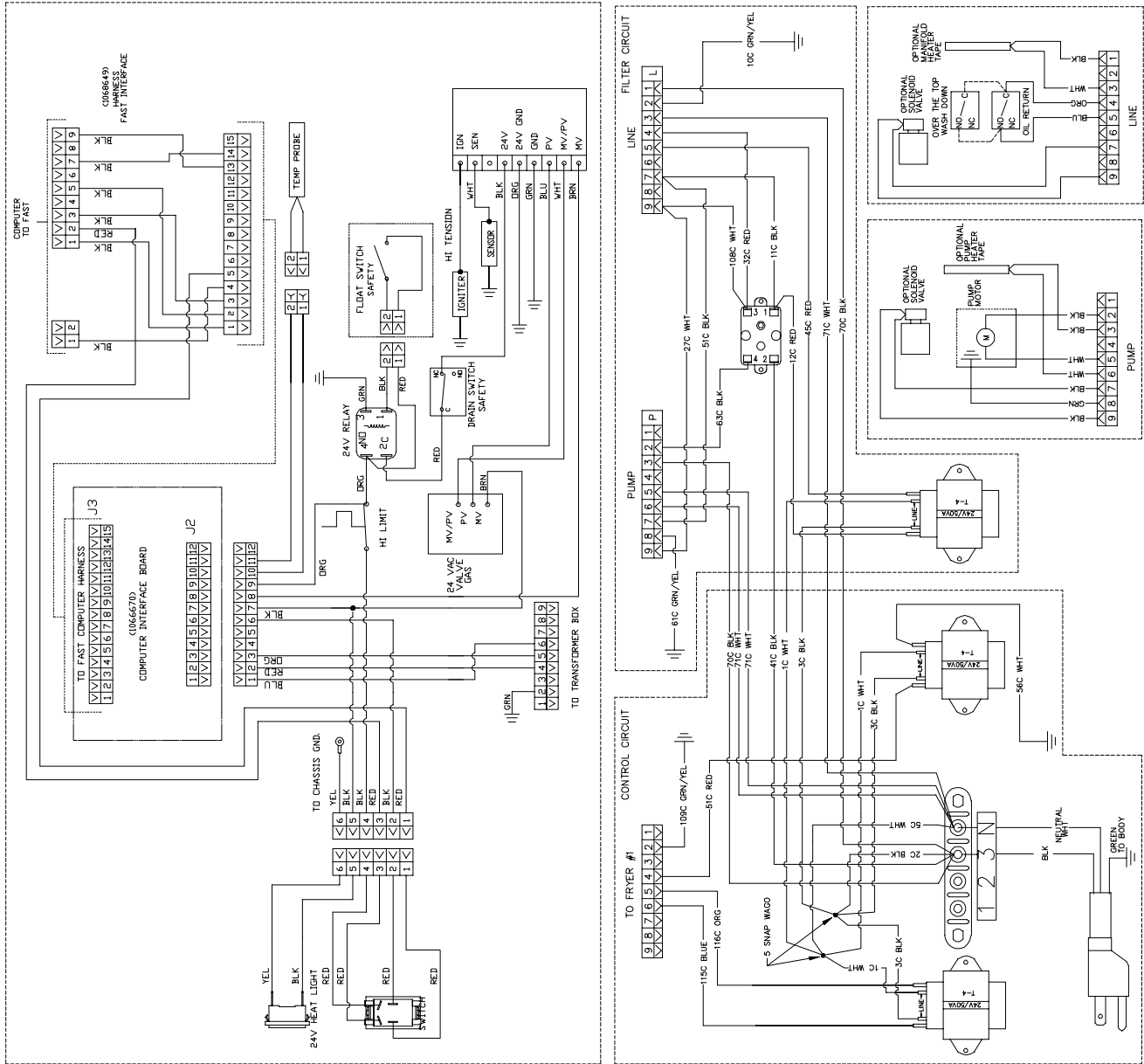

8051705C

HIGH EFFICIENCY DECATHLON SERIES GAS FRYERS

CHAPTER 1: SERVICE PROCEDURES

1.10.10 FAST Controller CE after Feb 09

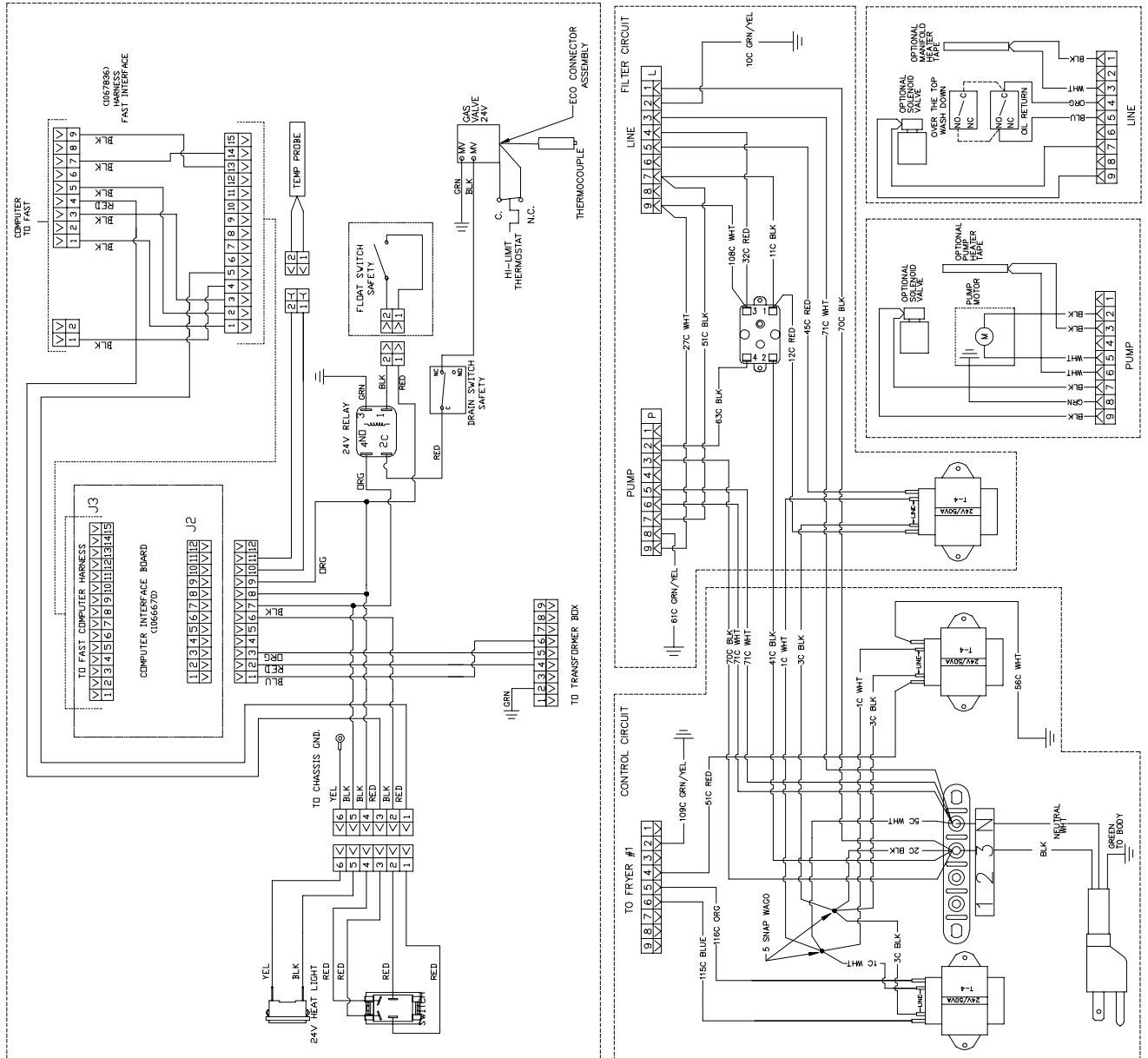

8051760B

HIGH EFFICIENCY DECATHLON SERIES GAS FRYERS

CHAPTER 1: SERVICE PROCEDURES

1.10.11 FAST Controller India

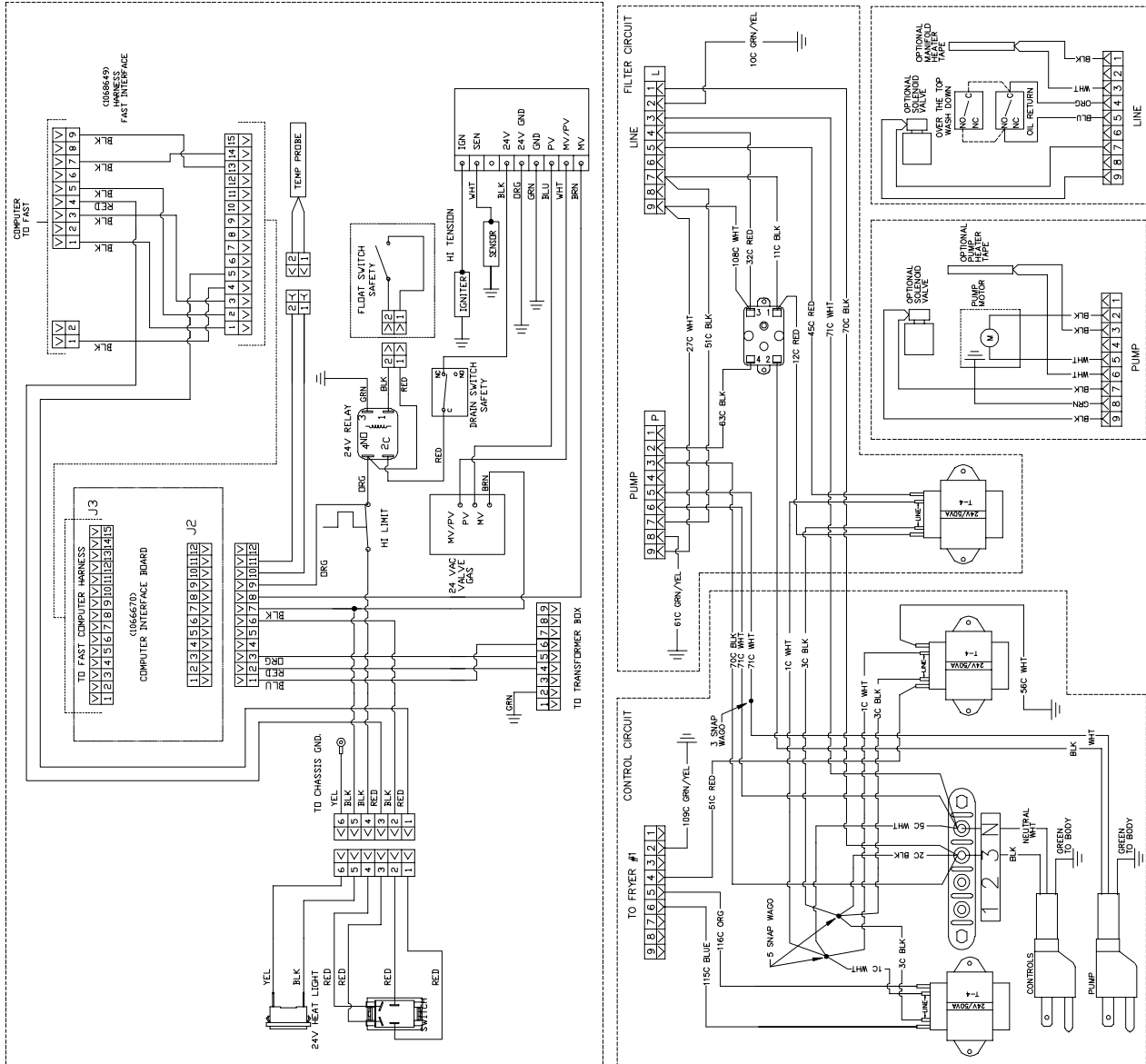

8051847A

HIGH EFFICIENCY DECATHLON SERIES GAS FRYERS

CHAPTER 1: SERVICE PROCEDURES

1.10.12 KFC-1 Controller

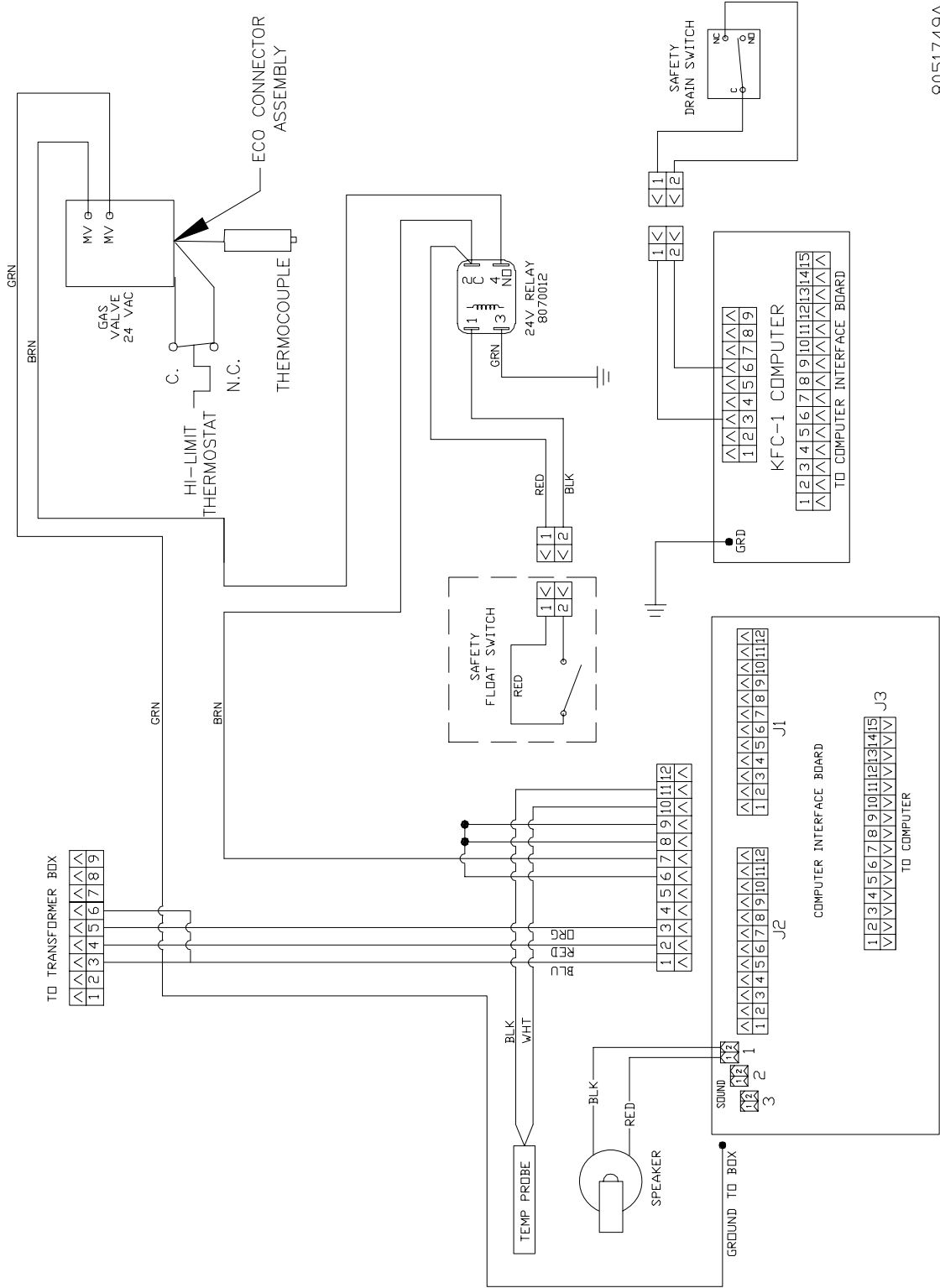

8051749A

HIGH EFFICIENCY DECATHLON SERIES GAS FRYERS

CHAPTER 1: SERVICE PROCEDURES

1.10.13 CM4S Controller

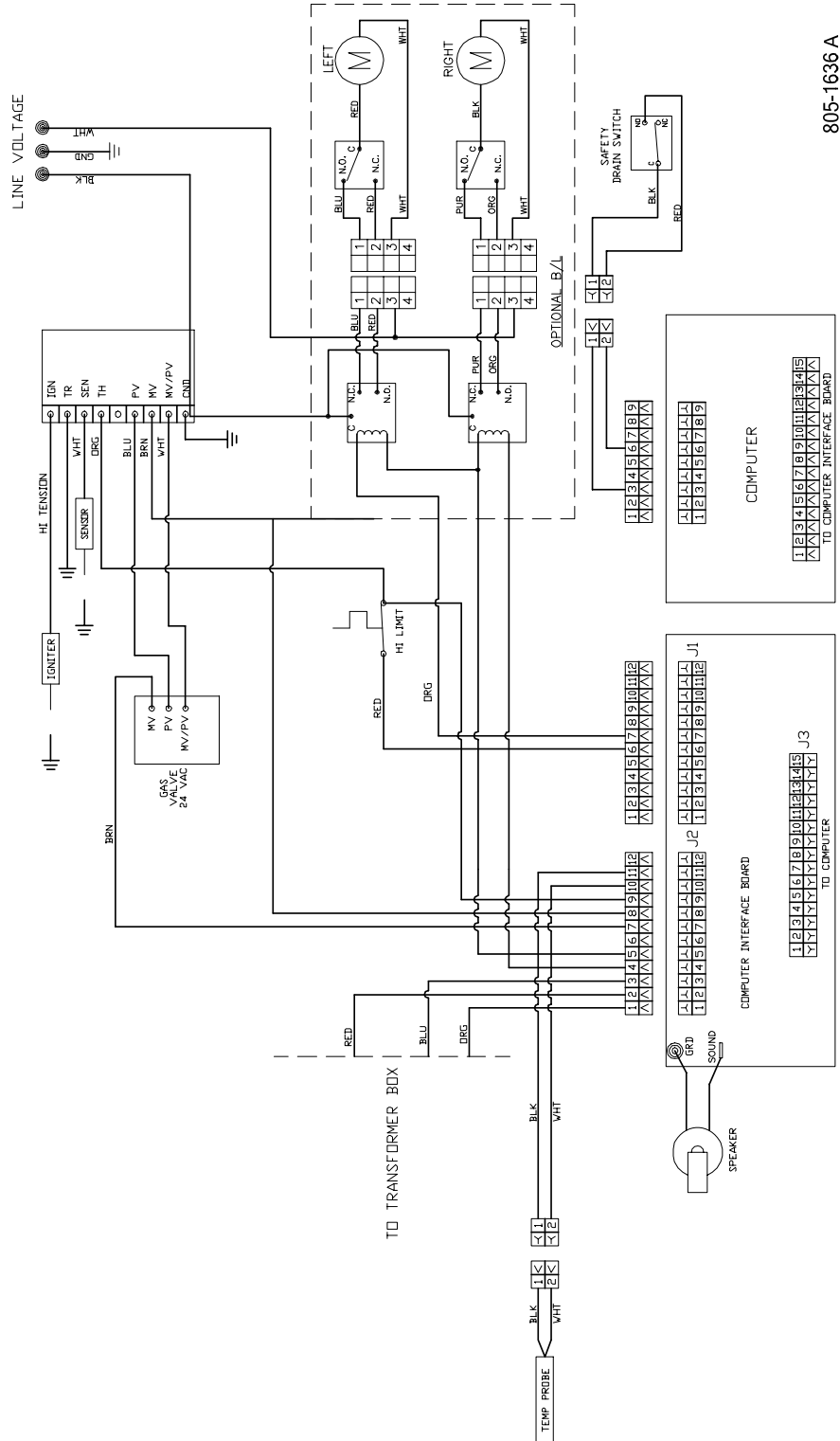

805-1636 A

HIGH EFFICIENCY DECATHLON SERIES GAS FRYERS

CHAPTER 1: SERVICE PROCEDURES

1.10.14 3000 Controller

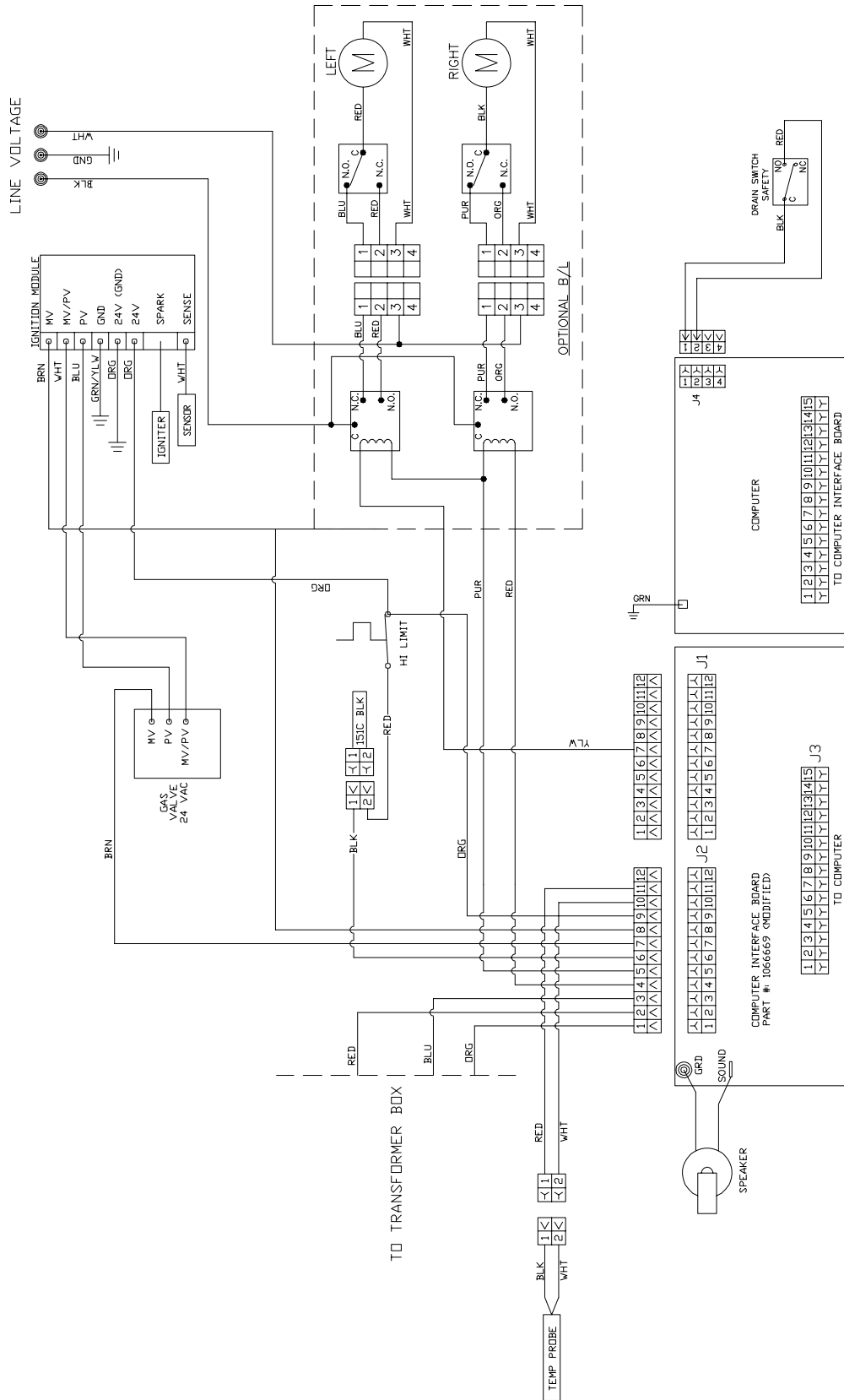

8051932A

HIGH EFFICIENCY DECATHLON SERIES GAS FRYERS

CHAPTER 1: SERVICE PROCEDURES

1.10.15 Constant Pilot, FAST Ready

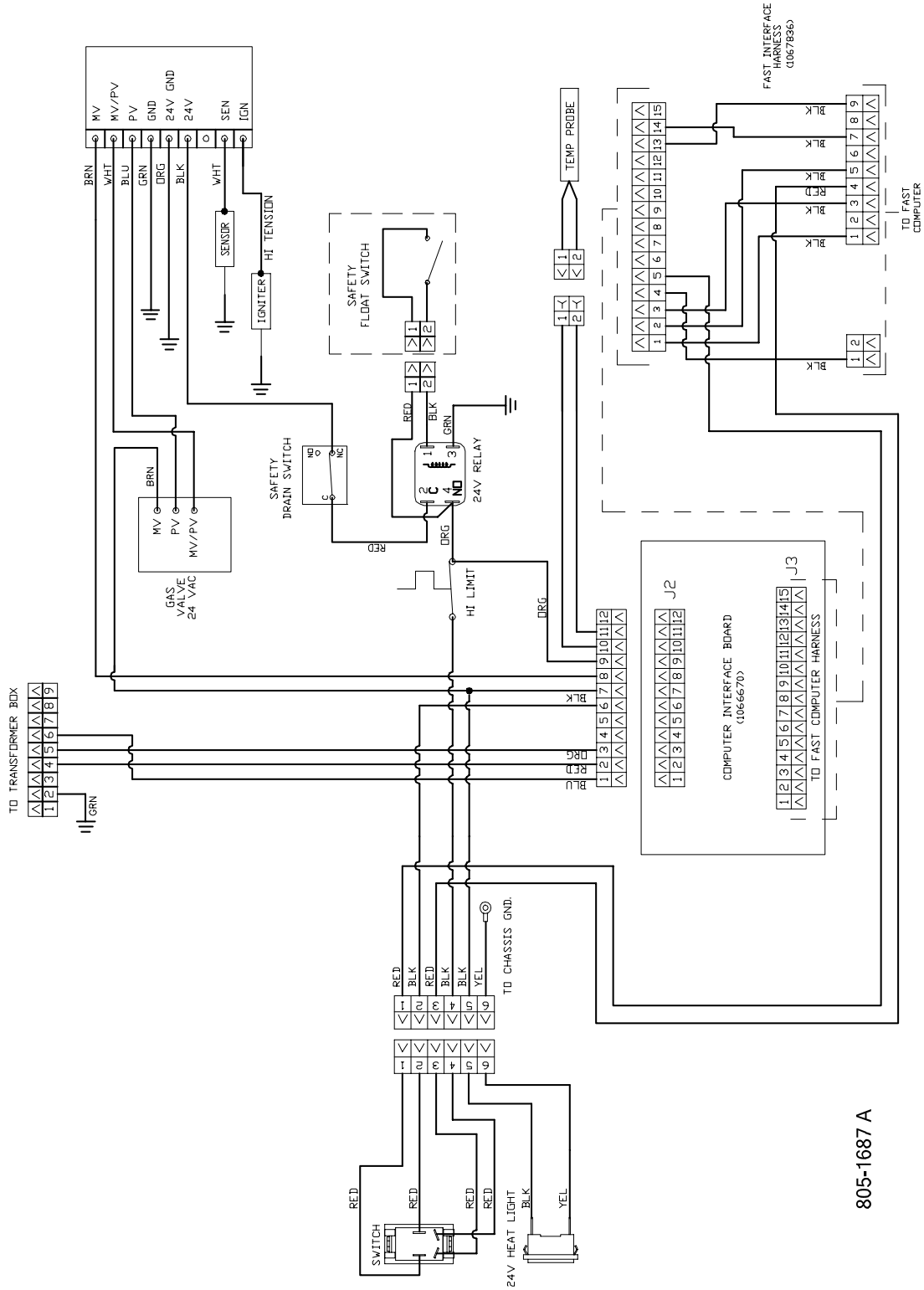

805-1687 A

**HIGH EFFICIENCY DECATHLON SERIES GAS FRYERS
CHAPTER 1: SERVICE PROCEDURES**

1.11 Probe Resistance Charts

Thermatron Probe Resistance Chart		
° Celsius	° Fahrenheit	Ohms (±3%)
21	70	108130
27	80	84606
32	90	66721
38	100	53020
43	110	42452
49	120	34206
54	130	27735
60	140	22641
66	150	18588
71	160	15349
77	170	12741
82	180	10635
88	190	8925
93	200	7527
99	210	6391
104	220	5470
110	230	4705
116	240	4030
121	250	3441
127	260	2967
132	270	2583
138	280	2255
143	290	1977
149	300	1729
154	310	1496
160	320	1320
166	330	1170
171	340	1051
177	350	942
182	360	840
188	370	750
193	380	676
199	390	605
204	400	541

Controller Probe Resistance Chart		
° Celsius	° Fahrenheit	Ohms (±3%)
21	70	1080
27	80	1101
32	90	1122
38	100	1143
43	110	1164
49	120	1185
54	130	1206
60	140	1226
66	150	1247
71	160	1268
77	170	1289
82	180	1309
88	190	1330
93	200	1350
99	210	1371
104	220	1391
110	230	1412
116	240	1432
121	250	1453
127	260	1473
132	270	1493
138	280	1514
143	290	1534
149	300	1554
154	310	1574
160	320	1594
166	330	1614
171	340	1634
177	350	1654
182	360	1674
188	370	1694
193	380	1714
199	390	1734
204	400	1754

HIGH EFFICIENCY DECATHLON SERIES GAS FRYERS

CHAPTER 2: PARTS LIST

2.1 High Efficiency Common Cabinet Decathlon (HDC) Primary Components

2.1.1 Decathlon HD50 Primary Components

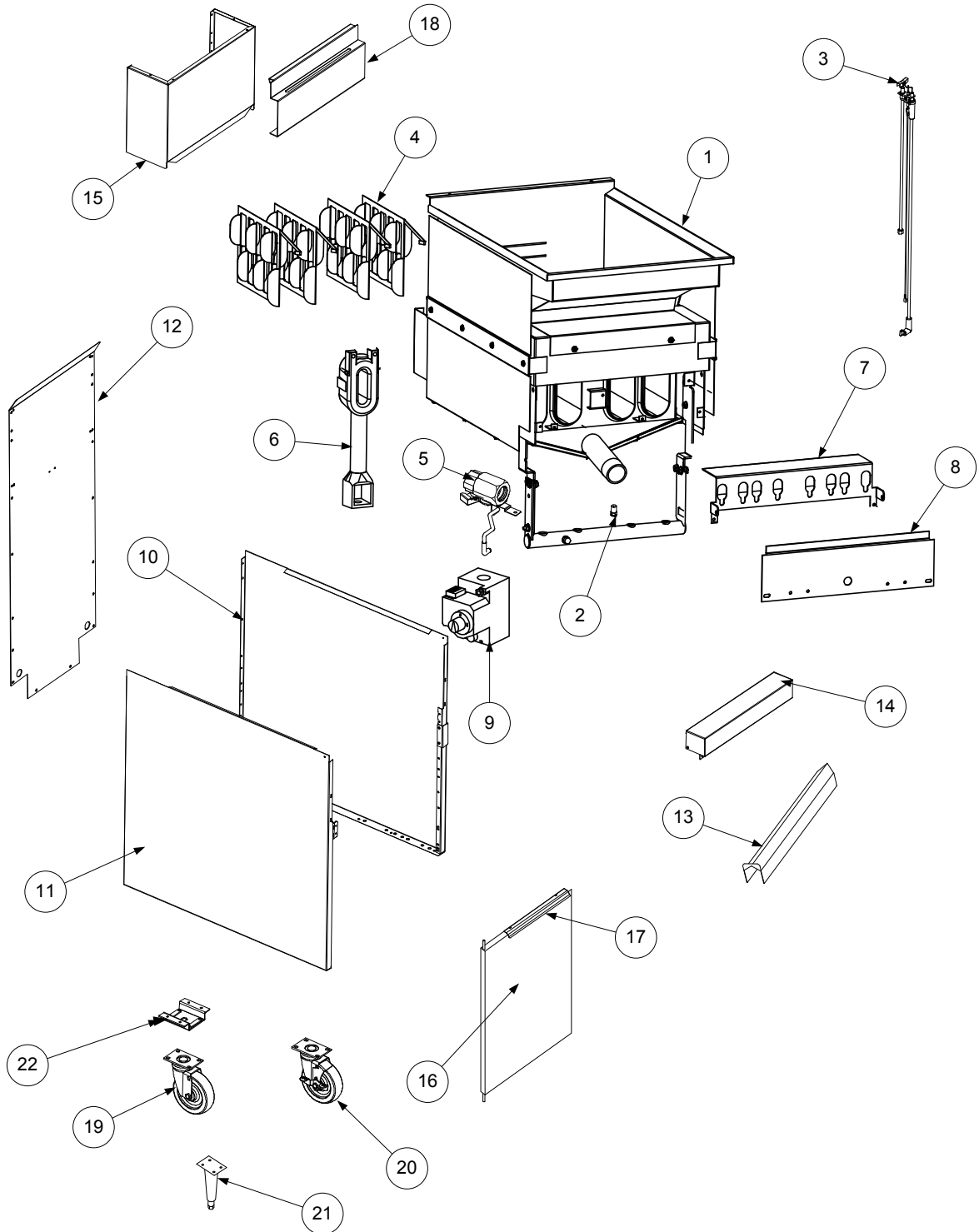

HIGH EFFICIENCY DECATHLON SERIES GAS FRYERS CHAPTER 2: PARTS LIST

Each section is labeled by size (e.g., D50) and parts are not interchangeable between different sized fryers. The parts in this manual are for use on Common Cabinet style fryer.

If you have any questions, call the Frymaster and Dean 24-Hour Service Hotline, 1-800-551-8633.

2.1.1 Decathlon HD50 Primary Components

ITEM	PART #	DESCRIPTION
1	826-3009	Frypot - S/S <i>(Use 108-3638 for Energy Star Frypot Assy.)</i>
2	▶▶▶	See Orifices, Section 2.2
3		See Additional Components and Controllers, Section 2.3
*	810-0705	Tube, 1/4" x 23" Pilot Gas Supply (one-piece gasline)
*	810-0703	Tube, 1/4" x 17 1/2" Pilot Gas Supply (one-piece gasline)
4	230-4900	Diffuser Assembly <i>(Use 230-6887 for Energy Star)</i>
5	▶▶▶	See Drain Components, Section 2.4
6	810-3356	Burner, High Efficiency
7	220-5287	Bracket, Burner Mounting
8	200-9063	Shield, Burner Heat <i>(Use 220-9949 for Energy Star)</i>
9		See Additional Components and Controllers, Section 2.3
10	231-2060	Side Panel, Left Side
11	232-2060	Side Panel, Right Side
12		Cabinet Back
*	220-1847	x1 (Single)
*	220-1806	x2 (2-battery)
*	220-1838	x3 (3-battery)
13	823-5932	Joiner Strip
14		Top Cap
	106-5433	x1 (Single)
	106-5955	x2 (2-battery)
	106-5956	x3 (3-battery)
	106-6333	x4 (4-battery)
	106-7631	x5 (5-battery)
15		Flue Cap
	230-1848	x1 (Single)
	230-1812	x2 (2-battery)
	230-1841	x3 (3-battery)
	230-1875	x4 (4-battery)
	230-2434	x5 (5-battery)
16	106-7542SP	Door Assembly (Left or Right)
17	210-8077	Handle, Door
*	810-2346	Magnetic Catch, Door
*	230-4998	Hinge, One-piece
18		Basket Lifts
	210-1595	Single (SCFHD50, 823-4075 with deflector)
	210-3131	Double (SCFHD50, 823-4074 with deflector)
19	810-0356	Caster, Plate-mount, 5" without Brake
*	826-1117	Caster Kit, Plate-mount, 5" without Brake (includes mounting hardware)
20	810-0357	Caster, Plate-mount, 5" with Brake
*	826-1118	Caster Kit, Plate-mount, 5" with Brake (includes mounting hardware)
*	810-0944	Caster, Plate-mount, 3" with Brake
*	810-1494	Caster, Plate-mount, 4" without Brake
*	106-7649	Cordset, 10' Power
21	810-2411	Leg, Single Bolt Mount (black)
*	810-3169	Leg Package, 4 Bolt Mount (4 per set)
22	823-3248	Leg Support Assembly

* Not illustrated.

HIGH EFFICIENCY DECATHLON SERIES GAS FRYERS
CHAPTER 2: PARTS LIST

2.1.2 Decathlon HD60/63 Primary Components

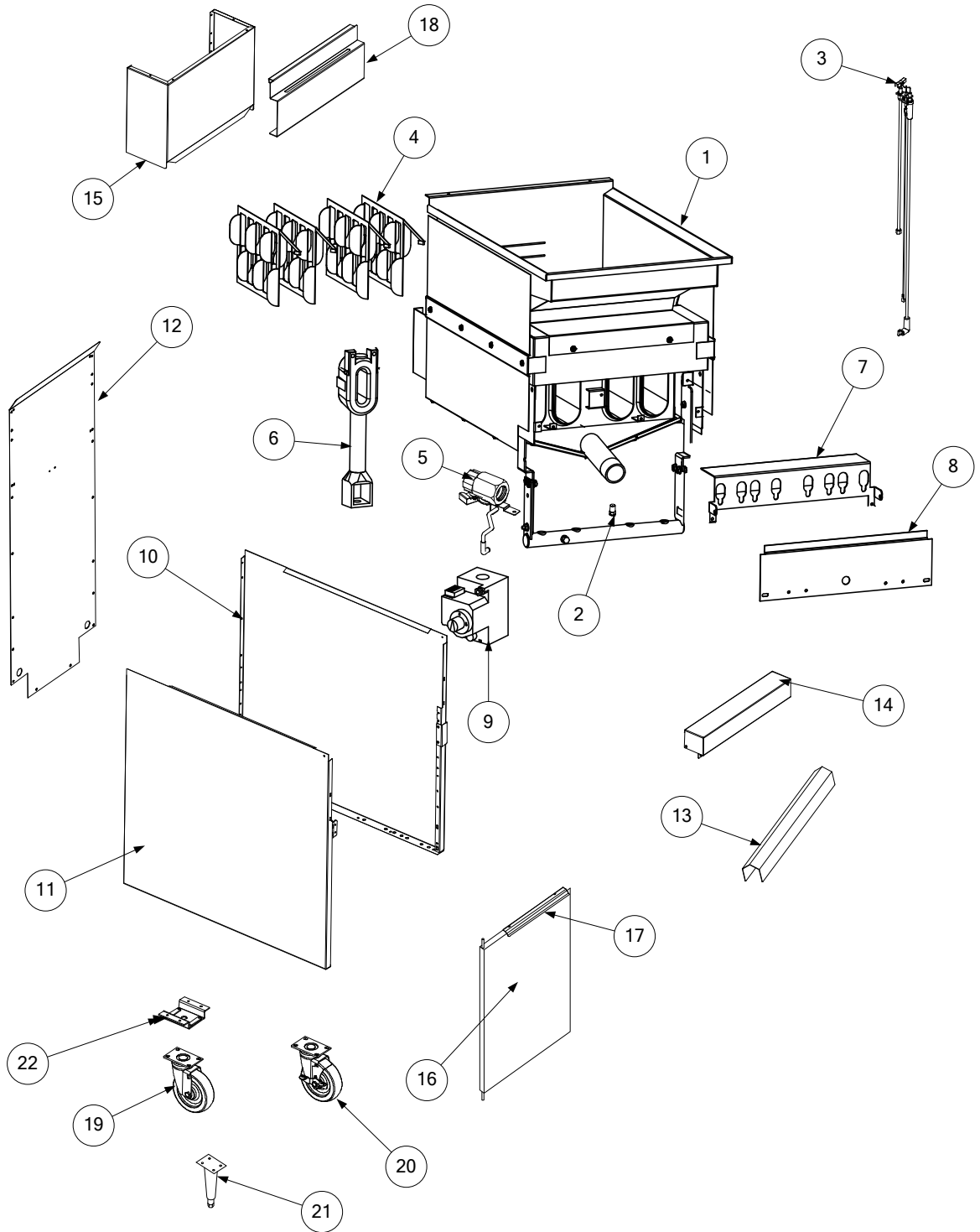

**HIGH EFFICIENCY DECATHLON SERIES GAS FRYERS
CHAPTER 2: PARTS LIST**

2.1.2 Decathlon HD60/63 Primary Components (cont.)

ITEM	PART #	DESCRIPTION
1	106-9632	Frypot - S/S
*	106-9634	Frypot - S/S (Single HD60 without filtration)
*	823-5742SP	Frypot - S/S (Single HD60 without filtration, Red Robin)
*	106-9638SP	Frypot - S/S (Single HD63 without filtration)
*	823-6314	Frypot - S/S (Single HD63 without filtration, Red Robin)
2	▶▶▶	See Orifices, Section 2.2
3		See Additional Components and Controllers, Section 2.3
*	810-0705	Tube, 1/4" x 23" Pilot Gas Supply (one-piece gasline)
*	810-0703	Tube, 1/4" x 17 1/2" Pilot Gas Supply (one-piece gasline)
*	810-0703	Tube, Pilot Gas Supply, 1/4" x 17.50" (one-piece gasline)
4	230-1431	Diffuser Assembly
5	▶▶▶	See Drain Components, Section 2.4
6	810-3356	Burner, High Efficiency
7	220-5152	Burner Bracket
8	200-8748	Shield, Burner Heat
9		See Additional Components and Controllers, Section 2.3
*	810-0691	Vent Tube
10	231-2311SP	Side Panel, Left Side
11	232-2311SP	Side Panel, Right Side
*	221-2737	Side Panel, Left Side (Filter Ready)
*	222-2737	Side Panel, Right Side (Filter Ready)
*	823-5744	Side Panel, with Splash Panel (660/363/663)
12		Cabinet Back (One-piece)
	220-1851	x1 (Single)
	220-1828	x2 (2-battery)
	220-3702	x2, without Deflector (2-battery)
	220-4518	x1, without Deflector (3-battery)
13	210-3017	Joiner strip
14		Top Cap
	106-5434	x1 (Single)
	106-5953	x2 (2- and 6-battery)
	106-6080	x3 (3- and 6-battery)
	106-4683	x4 (4- and 6-battery)
15		Flue Cap
	230-3078	x1 (Single)
	230-1833	x2 (2-battery)
	230-1890	x3 (3-battery)
	230-1891	x4 (4-battery)
	230-1890	x3 (6-battery)
	230-1891	x4 (6-battery)
16	106-4309SP	Door Assembly, left or right
17	210-8077	Handle, Door
*	810-2346	Magnet, Door
*	230-4998	Hinge, One-piece

* Not illustrated.

**HIGH EFFICIENCY DECATHLON SERIES GAS FRYERS
CHAPTER 2: PARTS LIST**

2.1.2 Decathlon HD60/63 Primary Components (cont.)

ITEM	PART #	DESCRIPTION
18		Basket Hanger
	210-2737SP	Single (60/63/65, 823-3649 with deflector)
	210-6763	Single (Church's 63, 823-6524 with deflector)
	823-7219	Single (Raising Cane's)
	210-6761	Double (Church's 63, 823-6523 with deflector)
	210-1482	Double (Chili's, 823-4999 with deflector)
	823-7152	Double (Raising Cane's)
19	810-0356	Caster, Plate-mount, 5" without Brake
*	826-1117	Caster Kit, Plate-mount, 5" without Brake (includes mounting hardware)
20	810-0357	Caster, Plate-mount, 5" with Brake
*	826-1118	Caster Kit, Plate-mount, 5" with Brake (includes mounting hardware)
*	810-0944	Caster, Plate-mount, 3" with Brake
*	810-1494	Caster, Plate-mount, 4" without Brake
*	106-7649	Cordset, 10' Power
21	810-2411	Leg, Single Bolt Mount (black)
*	810-3169	Leg, 4 Bolt Mount, Package (4 per set)
22	823-3248	Leg, Single Bolt Mount, Support Assembly

* Not illustrated.

HIGH EFFICIENCY DECATHLON SERIES GAS FRYERS
CHAPTER 2: PARTS LIST

2.1.3 Decathlon HD/FPHD65 Primary Components

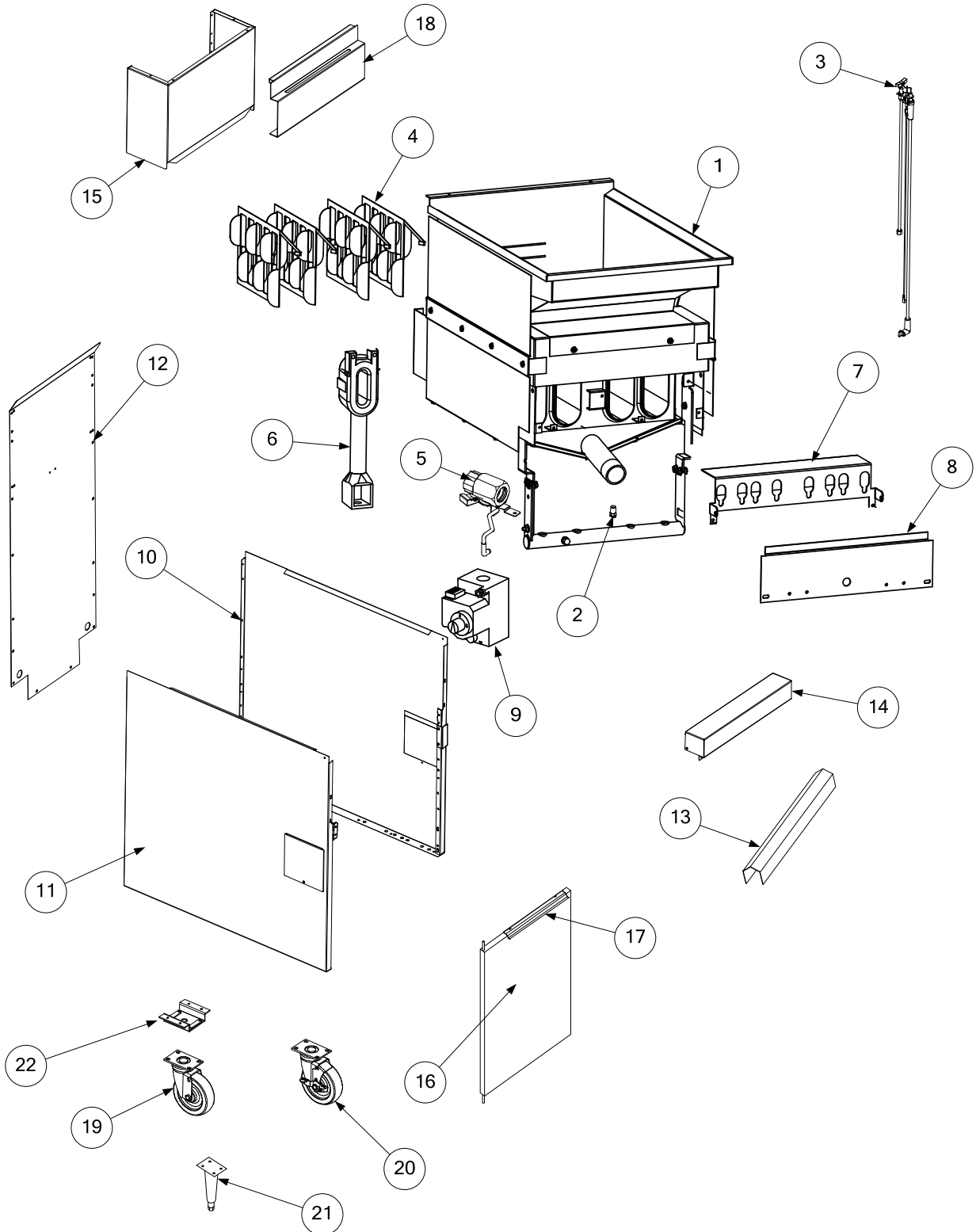

**HIGH EFFICIENCY DECATHLON SERIES GAS FRYERS
CHAPTER 2: PARTS LIST**

2.1.3 Decathlon HD/FPHD65 Primary Components (cont.)

ITEM	PART #	DESCRIPTION
1	106-9633	Frypot - S/S
2	▶▶▶	See Orifices, Section 2.2
3		See Additional Components and Controllers, Section 2.3
*	810-0705	Tube, Pilot Gas Supply, 1/4" x 23" (one-piece gasline)
*	810-0703	Tube, Pilot Gas Supply, 1/4" x 17 1/2" (one-piece gasline)
4	230-1431	Diffuser Assembly
5	▶▶▶	See Drain Components, Section 2.4
6	108-2612SP	Burner, High Efficiency
7	220-5152	Burner Bracket
8	200-8748	Shield, Burner Heat
9		See Additional Components and Controllers, Section 2.3
*	810-0691	Vent Tube
10		Side Panel, Left
	221-0012	Side Panel, Left Side with Hole (unit exterior)
	211-8078	Side Panel, Left Side (unit exterior)
	231-2311	Side Panel, Left Side (Single 65)
11		Side Panel, Right
	222-0012	Side Panel, Right Side with Hole (unit exterior)
	212-8078	Side Panel, Right Side (unit exterior)
	232-2311	Side Panel, Right Side (Single 65)
	823-5789	Side Panel, with Splash Panel (565)
12		Cabinet Upper Back
	220-2353	x2 (2-, 4-, 5-, and 6-battery)
	220-0668	x3 (5-battery)
		Cabinet Lower Back
	220-2354	x2 (2-, 4-, 5-, and 6-battery)
	220-0667	x3 (5-battery)
		Cabinet Full Back
	220-1851	x1 (one-piece)
	220-1828	x2 (one-piece)
13	230-1478	Joiner Strip
14		Top Cap
	106-5434	x1 (Single)
	106-5953	x2 (2-battery)
	824-1871	x3 (3-battery)
	823-5976	x4 (4-battery and 6-battery)
	823-5975	x2 (5-battery and 6-battery)
	823-6090	x3 (5-battery)
	230-2472	x1 (HD marine edge)
15		Flue Cap
	230-3078	x1 (Single)
	230-1833	x2 (2-battery)
	230-2323	x3 (3-battery and 5-battery)
	230-2298	x2 (5-battery and 6-battery)
*	200-3649	Deflector, Flue (Single, HD, non-S/S) (use screws 809-0437)
*	210-6525	Deflector, Flue (Single, Chili's, S/S) (use screws 809-0437)

* Not illustrated.

**HIGH EFFICIENCY DECATHLON SERIES GAS FRYERS
CHAPTER 2: PARTS LIST**

2.1.3 Decathlon HD/FPHD65 Primary Components (cont.)

ITEM	PART #	DESCRIPTION
16	106-7710	Door Assembly, left or right
17	210-8077	Handle, Door
*	810-2346	Magnet, Door
*	230-4998	Hinge, Lower
*	823-5137	Hinge, Upper Right
*	823-5136	Hinge, Upper Left
18	823-5859	Basket Hanger, Church's (with Deflector)
*	823-5801	Basket Hanger, Chili's Single System, 6" Splash Guard
*	823-5856	Splash Guard (2-, 4-, 5-, and 6-battery)
19	810-1494	Caster, Plate-mount 4" without Brake
20	810-2406	Caster, Plate-mount 5" without Brake
*	810-0944	Caster, Plate-mount 3" with Brake
*	807-0154	Cordset, 10' Power
21	810-2411	Leg, Single Bolt Mount (black)
*	810-3169	Leg, 4 Bolt Mount, Package (4 per set)
22	823-3248	Leg, Single Bolt Mount Support Assembly,

* Not illustrated.

HIGH EFFICIENCY DECATHLON SERIES GAS FRYERS
CHAPTER 2: PARTS LIST

2.1.4 Decathlon LHDC65 Primary Components

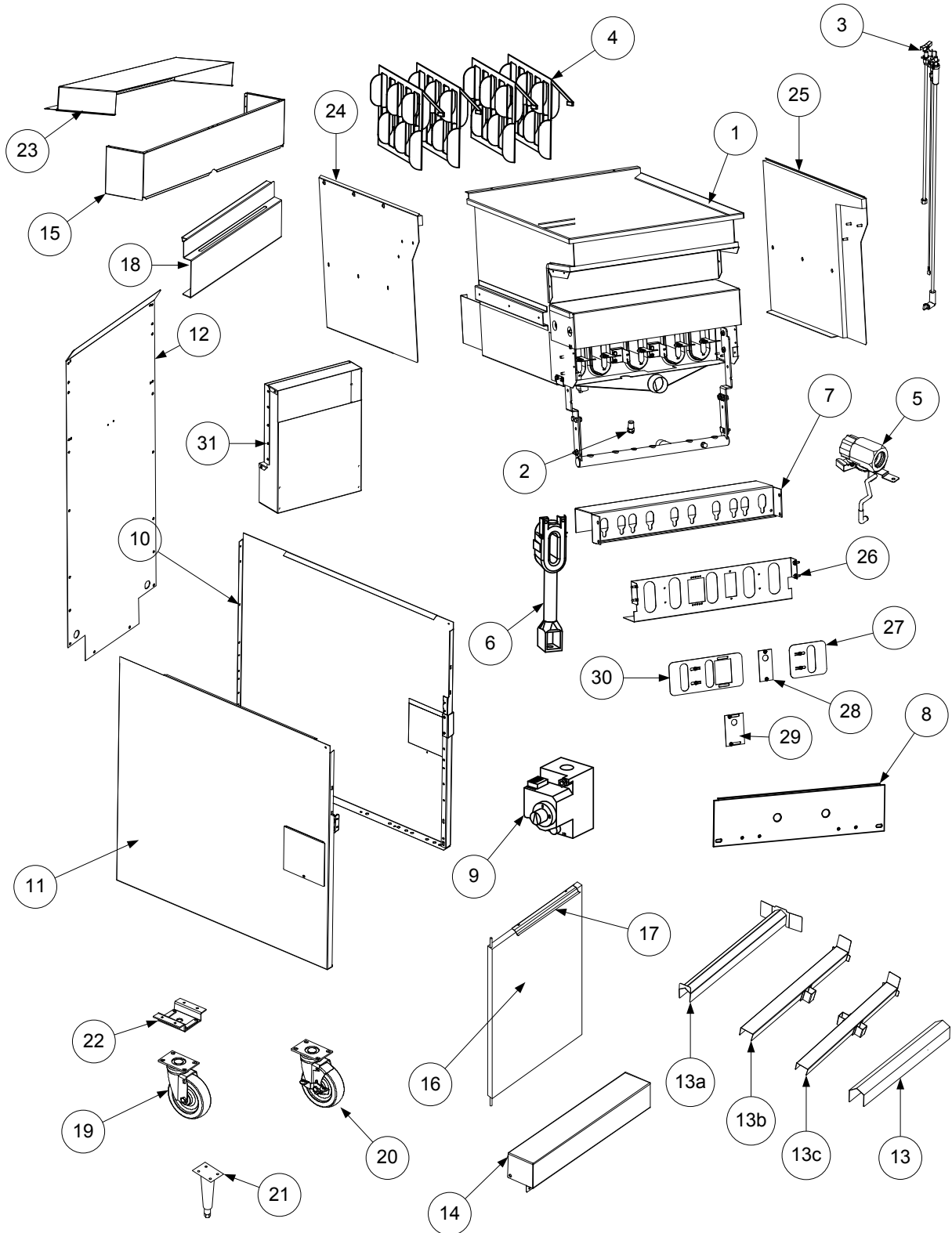

**HIGH EFFICIENCY DECATHLON SERIES GAS FRYERS
CHAPTER 2: PARTS LIST**

2.1.4 Decathlon LHDC65 Primary Components (cont.)

ITEM	PART #	DESCRIPTION
1	823-7565	Frypot - S/S Filter
*	823-7567	Frypot – S/S Non-Filter
2	▶▶▶	See Orifices, Section 2.2
3		See Additional Components and Controllers, Section 2.3
*	810-0705	Tube, Pilot Gas Supply, 1/4" x 23" (one-piece gas line)
*	810-0703	Tube, Pilot Gas Supply, 1/4" x 17 1/2" (one-piece gas line)
4	230-1431	Diffuser Assembly
5	▶▶▶	See Drain Components, Section 2.4
6	108-2612SP	Burner, High Efficiency
7	220-9905	Burner Bracket
8	200-9948	Shield, Burner Heat
9		See Additional Components and Controllers, Section 2.3
*	810-0691	Vent Tube
10		Side Panel, Left
	221-0012	Side Panel, Left Side with Hole (unit exterior)
	211-8078	Side Panel, Left Side (unit exterior)
	231-2311	Side Panel, Left Side (Single 65)
11		Side Panel, Right
	222-0012	Side Panel, Right Side with Hole (unit exterior)
	212-8078	Side Panel, Right Side (unit exterior)
	232-2311	Side Panel, Right Side (Single 65)
	823-5789	Side Panel, with Splash Panel (565)
12		Cabinet Full Back
	220-9325	Single
	220-9485	Double (2-, 4-, 5-, and 6-battery)
	220-9849	Triple (3-, and 5-battery)
		Joiner Strip
13	230-1478	Connecting without pins
*	823-5961	Connecting with pins (same as 230-1478 but with pins)
13a	823-8776	Connecting without pin and without holsters
*	823-7278	Connecting with pins and without holsters (same as 823-8776 but with pins)
13b	823-8829	Connecting with single holster on right
13c	823-7917	Connecting with double holsters
14		Top Cap
	824-2317	Single
	824-2318	x2 (2-battery, 5-battery and 6-battery)
	824-2319	x3 (3-battery and 5-battery)
	823-2320	x4 (4-battery and 6-battery)
15		Flue Cap
	824-2310	Single
	824-2314	x2 (2-battery, 5-battery and 6-battery)
	824-2315	x3 (3-battery and 5-battery)
	824-2316	X4 (4-battery and 6-battery)
*	200-3649	Deflector, Flue (Single, HD, non-S/S) (use screws 809-0437)
*	210-6525	Deflector, Flue (Single, Chili's, S/S) (use screws 809-0437)
*	230-9973	Cover, HD65 90° Flue

* Not illustrated.

**HIGH EFFICIENCY DECATHLON SERIES GAS FRYERS
CHAPTER 2: PARTS LIST**

2.1.3 Decathlon LHDC65 Primary Components (cont.)

ITEM	PART #	DESCRIPTION
16	106-7710	Door Assembly, left or right
17	210-8077	Handle, Door
*	810-2346	Magnet, Door
*	230-4998	Hinge, Lower
*	823-5137	Hinge, Upper Right
*	823-5136	Hinge, Upper Left
18	823-5859	Basket Hanger, Church's (with Deflector)
*	823-5801	Basket Hanger, Chili's Single System, 6" Splash Guard
*	823-5856	Splash Guard (2-, 4-, 5-, and 6-battery)
19	810-1494	Caster, Plate-mount 4" without Brake
20	810-2406	Caster, Plate-mount 5" without Brake
*	810-0944	Caster, Plate-mount 3" with Brake
*	807-0154	Cordset, 10' Power
21	810-2411	Leg, Single Bolt Mount (black)
*	810-3169	Leg, 4 Bolt Mount, Package (4 per set)
22	823-3248	Leg, Single Bolt Mount Support Assembly,
23		Weldment, Vent
	823-2309	Single and 5-battery
	823-2311	2-battery, 5 battery and 6-battery
	823-2312	3-battery and 5-battery
	823-2313	4-battery and 6-battery
24	108-4284	Side Assembly, Frypot with Insulation Left
25	108-4285	Side Assembly, Frypot with Insulation Right
26	220-9906	Box, Burner Air
27	240-0319	Shutter, Burner
28	220-8858	Door, Ignitor
29	220-8865	Door, Ignitor Access
30	240-0320	Shutter, Long Burner
31	108-4062	Flue Assembly 90°
*	108-5788	Cordset, 10' Power

* Not illustrated.

HIGH EFFICIENCY DECATHLON SERIES GAS FRYERS
CHAPTER 2: PARTS LIST

2.1.5 Y/KSCF/C/HC Primary Components

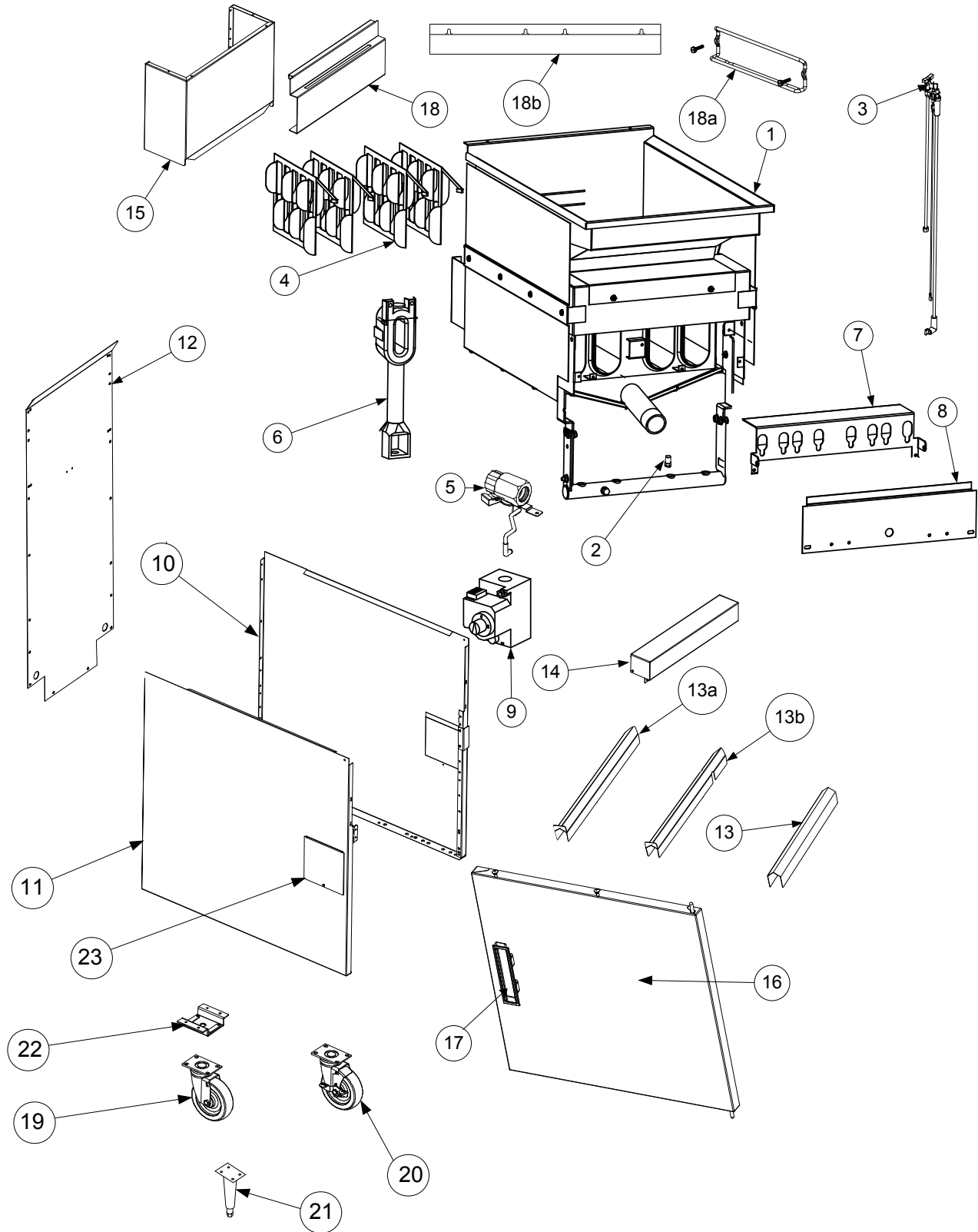

**HIGH EFFICIENCY DECATHLON SERIES GAS FRYERS
CHAPTER 2: PARTS LIST**

2.1.4 Y/KSCF/C/HC Primary Components (cont.)

ITEM	PART #	DESCRIPTION
1	823-6138	Frypot – S/S (YSCFHC 14)
*	106-9637	Frypot – S/S (YSCFHC 18)
*	823-6367	Frypot – S/S (Y/KSCF/C/HC 18) India without hooks
*	823-7879	Frypot – S/S (Y/KSCF/C/HC 18) India with hooks
2	▶▶▶	See Orifices, Section 2.2
3		See Additional Components and Controllers, Section 2.3
*	810-0705	Tube, Pilot Gas Supply, ¼" x 23" (one-piece gasline)
*	810-0703	Tube, Pilot Gas Supply, ¼" x 17½" (one-piece gasline)
4	230-4900	Diffuser Assembly (use 230-6888 for 8 row burner) (use 230-7711 for India)
5	▶▶▶	See Drain Components, Section 2.4
6	810-3356	Burner, High Efficiency
*	810-2151	Burner, Left
*	810-2149	Burner, Center
*	810-2150	Burner, Right
7	220-5152	Burner Mounting (use 200-2738 for India)
8	200-8748	Heat shield
9		See Additional Components and Controllers, Section 2.3
*	810-0691	Vent Tube
10	231-2060	Side Panel, Left Side (unit exterior) (use 221-3272 for India) (use 231-8145 for SS 318G) (use 221-8141 318G Painted)
11	232-2060	Side Panel, Right Side (unit exterior) (use 222-3272 for India) (use 232-8145 for SS 318G) (use 222-8141 318G Painted)
12	220-1828	Back Panel
13	210-1355	Joiner Strip
13a	823-6922	Joiner Strip
13b	823-7924	Joiner Strip (India slotted for hooks)
14		Top Caps
	106-7984	214
	106-7985	314
	106-7669	218 (use 106-9625 for India)
	106-9785	318
15		Flue Caps
	823-6292	214
	823-6300	314
	230-1833	218 (use 823-6880 for India before Feb. 11) (use 823-7875 for India after Feb. 11)
	823-6974	318 (use 230-1890 for YSCFHC318G)
16	106-8511	Door, left or right
17	810-3335	Handle, Push-in
*	810-2346	Magnet, Door
*	230-4998	Hinge, One Piece
18	810-2793	Basket Hanger, Double
18a	810-2794	Basket Hanger, Double Wireform
18b	230-8002	Basket Hanger, Double Keyholed (India)
	230-8757	Basket Hanger, Triple Keyholed
19	810-0356	Caster, Plate-mount 5" without Brake (use 826-1138 for India)
20	810-0357	Caster, Plate-mount 5" with Brake
*	106-7649	Cordset, 10' Power
21	810-2411	Leg, Single Bolt Mount (black)
*	810-3169	Leg, 4 Bolt Mount, Package (4 per set) (use 810-3168 for India)
22	823-3248	Leg, Single Bolt Mount Support Assembly

* Not illustrated.

HIGH EFFICIENCY DECATHLON SERIES GAS FRYERS
CHAPTER 2: PARTS LIST

2.1.6 BK1814 Primary Components

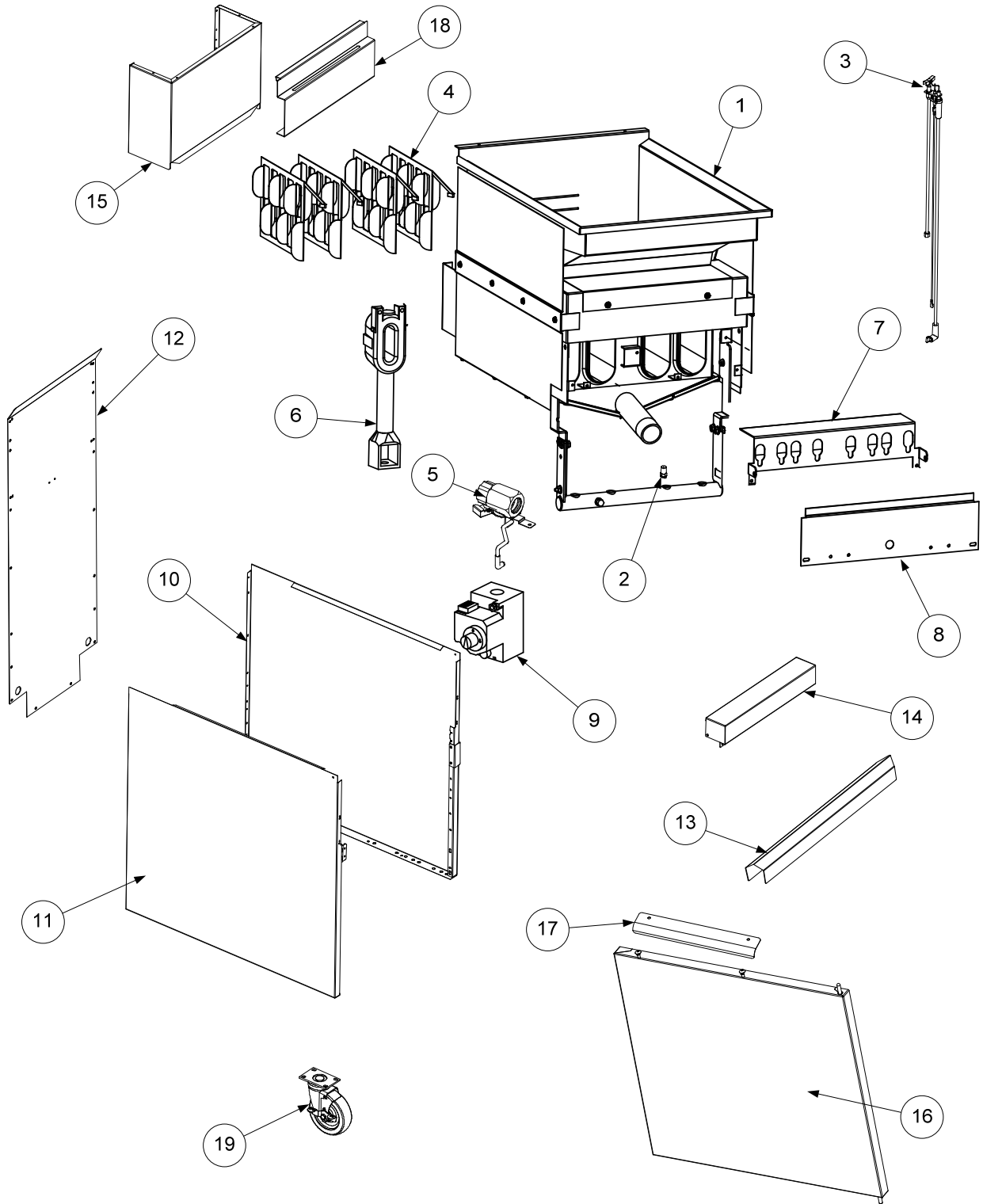

**HIGH EFFICIENCY DECATHLON SERIES GAS FRYERS
CHAPTER 2: PARTS LIST**

2.1.5 BK1814 Primary Components (cont.)

ITEM	PART #	DESCRIPTION
1	823-7554	Frypot (BK50)
*	823-6997	Frypot (BK60)
2	▶▶▶	See Orifices, Section 2.2
3		See Additional Components and Controllers, Section 2.3
*	810-0703	Tube, Pilot Gas Supply, 1/4" x 17 1/2" (one-piece gas line)
4	230-6887	Diffuser (Baffle) Assembly
5	▶▶▶	See Drain Components, Section 2.4
6	810-3356	Burner, High Efficiency Cast
7	220-5152	Burner Mounting
8	200-8748	Heat shield
9		See Additional Components and Controllers, Section 2.3
*	810-0691	Vent Tube
10	231-2060	Side Panel, Left Side (unit exterior)
*	231-6259	Side Panel, Left Side BK RAM Inner
11	232-2060	Side Panel, Right Side (unit exterior)
*	232-6259	Side Panel, Right Side BK RAM Inner
12		Back Panels
	220-6434	60/50 BK60/50/RAM/60 (use 220-6432 for RAM/60 - RAM on right)
	220-7150	50/60 BK60/RAM/50/60 (use 220-7151 for 60/RAM - RAM on left)
	220-6270	BK160
	220-6754	BK260
	220-7268	BK60/50/60
	230-6427	RAM Back Cover with cutout for receptacle
13	823-7515	Joiner Strip
14		Top Caps
	108-0971	BK60/50 (BK1814 - 60/50/RAM/60)
	108-1590	BK50/60 (BK1814 - 60/RAM/50/60)
	108-0975	BK60/160
	108-3606	BK260
	108-1750	BK60/50/60
15		Flue Caps
	230-6268	BK60/50 (BK1814 - 60/50/RAM/60)
	230-6431	RAM/60 (BK1814 - 60/50/RAM/60)
	230-7143	60/RAM (BK1814 - 60/RAM/50/60)
	230-7142	BK50/60 (BK1814 - 60/RAM/50/60)
	230-8800	BK160
	230-6705	BK260
	230-7238	BK60/50/60
16		Door, Left or Right
	106-4309	BK60
	106-7542	BK50
17	210-8077	Handle
*	810-2346	Magnet, Door
*	230-7192	Hinge, One Piece
18		Basket Hanger
	823-7773	BK60/50 or BK50/60 (BK1814 - 60/50/RAM/60 or 60/RAM/50/60)
	823-7770	BK160 or RAM/60 (BK1814 - 60/50/RAM/60)
	823-7774	60/RAM (BK1814 - 60/RAM/50/60)
	823-7771	BK260
	823-7772	BK60/50/60
19	810-2280	Caster, Plate-mount 5" with Brake
*	106-7649	Cordset, 120V 10' Power
*	807-5003	Receptacle, RAM 15A 125V
*	108-2582	Relay, Control Assy BK1814/HD50 includes 807-4114 and wire harness
*	812-2185SP	Relay, Time Delay

* Not illustrated.

**HIGH EFFICIENCY DECATHLON SERIES GAS FRYERS
CHAPTER 2: PARTS LIST**

2.2 Orifices

ITEM	PART #	COMPONENT
		Natural Orifices
*	810-2060	2.40 mm CE
*	810-3801	2.35 mm (China)
*	810-3132	2.20 mm
*	810-2938	0-1999 ft. 2.26mm
*	810-3053	2000-3999 ft. 2.18mm
*	810-3054	4000-5999 ft. 2.10mm
*	810-2058	2.08mm used on LHDC65 #45
*	810-4285	2.06mm used on LHDC65 #46
*	810-3055	6000-7999 ft. 2.04mm
*	810-3056	8000-8999 ft. 1.98mm
*	810-3057	9000-10000 ft. 1.94mm
		Propane Orifices
*	810-2939	0-1999 ft. 1.40mm
*	810-2940	0-1999 ft. 1.32mm (LP-Butane Mix)
*	810-3058	2000-3999 ft. 1.35mm
*	810-2497	1.32mm used on LHDC65 #55
*	810-3059	4000-5999 ft. 1.30mm
*	810-3060	6000-7999 ft. 1.26mm
*	810-3061	8000-8999 ft. 1.22mm
*	810-3062	9000-10000 ft. 1.20mm
*	810-0710	1.40 mm
*	810-2059	1.51 mm (100% Butane India)

* Not illustrated.

HIGH EFFICIENCY DECATHLON SERIES GAS FRYERS

CHAPTER 2: PARTS LIST

2.3 Additional Components and Controllers

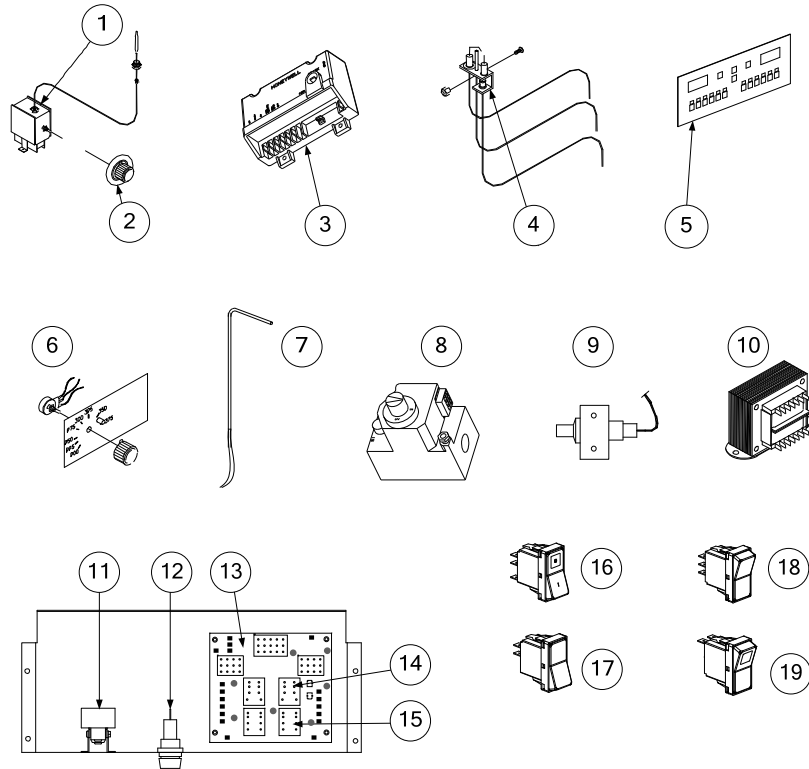

ITEM	PART #	DESCRIPTION
1	826-2013	Thermostat, Sunne
2	810-2035	Knob, Thermostat
3	826-2117	Spark Module (module, 807-4383, and rajah connector, 807-4375)
*	106-7535SP	Ignition Cable (for controller operated fryers)
4		Pilot Assemblies
	106-1839SP	Natural Gas, Electronic Ignition with Controller includes ignition cable Non-CE
	108-2787	Natural Gas, Electronic Ignition with Controller includes ignition cable CE
	106-1238SP	Natural Gas, Electronic Ignition without Controller Non-CE
	108-2990	Natural Gas, Electronic Ignition without Controller CE
	106-6752SP	Natural Gas, Trailing Pilot Non-CE
	108-2785	Natural Gas, Trailing Pilot CE
	106-1128SP	LP Gas, Electronic Ignition with Controller includes ignition cable Non-CE
	108-2788	LP Gas, Electronic Ignition with Controller includes ignition cable CE
	KIT6627	LP Gas, Electronic Ignition without Controller Non-CE
	108-2991	LP Gas, Electronic Ignition without Controller CE
	KIT8899	LP Gas, Trailing Pilot Non-CE
	108-2786	LP Gas, Trailing Pilot CE
*	807-1310	Flame Sensor
*	220-4626	Air Shutter (screw, 809-0931)
*	807-4199	Cable Assembly, Controller to Interface Board (SMT)
5		Controllers
	106-7141	Controller, Compu-Fry III.5, Full-vat
	826-2413	Controller, Compu-Fry III.5 (HD60, Red Robin)
	826-2304	Generic Digital Controller
	106-6022	Controller, Analog
	826-2858	Controller, Wingstreet
	108-4717	Controller, 3000 (Church's)
	108-0376	Controller, CM4-S (with bezel)

* Not illustrated.

HIGH EFFICIENCY DECATHLON SERIES GAS FRYERS CHAPTER 2: PARTS LIST

2.3 Additional Components and Controllers (cont.)

ITEM	PART #	DESCRIPTION
	826-2323	Basket Lift Timer (General Market, HD60, Red Robin)
	826-2385	Basket Lift Timer (HD63, Red Robin)
	108-1351	Controller, 3-Lane (Burger King)
6	826-2269	Potentiometer Kit, Dean
*	106-3729	Kit, Thermatron, 24VAC, Extended Melt Cycle
*	810-0110	Knob, Thermatron Controller
*	230-4625	Face Plate, 3-switch, Thermatron
*	810-3141	Sound Device
*	806-3660	Sound Device, High Output
7	106-5419SP	Probe Assembly, Temperature (Thermatron and FAST)
*	826-2423	Probe Assembly, Temperature (Dean controller) (BK 3-Lane)
8		Gas Valves
	807-3552	Natural Gas, Electronic Ignition
	807-3628	Propane Gas, Electronic Ignition
	807-3294	Natural Gas, Constant Pilot
	807-3295	Propane Gas, Constant Pilot
	807-2091	G20/25 (CE only)
	807-2127	G31 (CE only)
9	44970SP	Piezo Ignition Assembly
	810-1001	Piezo Igniter (trigger)
	200-1868	Piezo Bracket
	807-3540	Electrode, Piezo
	807-3650	Lead Wire, Piezo
10	807-2176	Transformer, 100/120-12/24 VAC Dual Voltage
*	807-0800	Transformer, 120/24 VAC
11	807-3680	High-limit Thermostat, Manual Reset 450° F (232° C)
*	210-4628	Bracket, Frypot Sensors (requires tack welding to heat tube)
*	210-4629	Bracket, Frypot Controller Probe (requires tack welding to heat tube)
12	807-1321	Fuse Holder, Buss
*	807-3843	Fuse, 3A Subminiature (250V)
*	807-3592	Fuse, 2A Slow-blow (230V)
*	807-3750	Fuse, 5A (120V)
13		Interface Boards
	826-2434	Standing Pilot (<i>use 106-6670 for FAST</i>)
	826-2425	Basket Lift
	106-9669	YUM/Wingstreet Interface Board
*	807-4199	Cable Assembly, SMT Controller to Interface Board
*	807-4597	Control Harness D-Series Wiring
14	807-0834	Relay, 12VDC 15A SPDT (basket lift)
15	807-0833	Relay, 12VDC 5A DPDT (latching)
*	807-4114	Relay, 24VAC Coil, Reset
*	106-6657	Pump Relay (includes 807-4114 and drain safety wiring)
*	807-0012	Pump Relay 18 amp 24V coil
16	807-3574	Switch, Power (green lens)
17	807-3580	Switch, Rocker, Manual Filter Power
18	807-3579	Switch, Six-terminal Boil-out
19	807-3576	Switch, Fryer Reset (momentary)
*	807-3578	Switch, 3-position, ON-OFF-ON
*	807-3575	Switch, Blank Insert
*	807-3577	Circuit Breaker, 7 amp
*	807-4112	Indicator Light, Green, 24V
*	807-4111	Indicator Light, White, 24V
*	807-3581	Indicator Light, Red, 120V

* Not illustrated.

HIGH EFFICIENCY DECATHLON SERIES GAS FRYERS
CHAPTER 2: PARTS LIST

2.4 Drain System Components

2.4.1 3" Drain Manifold Components

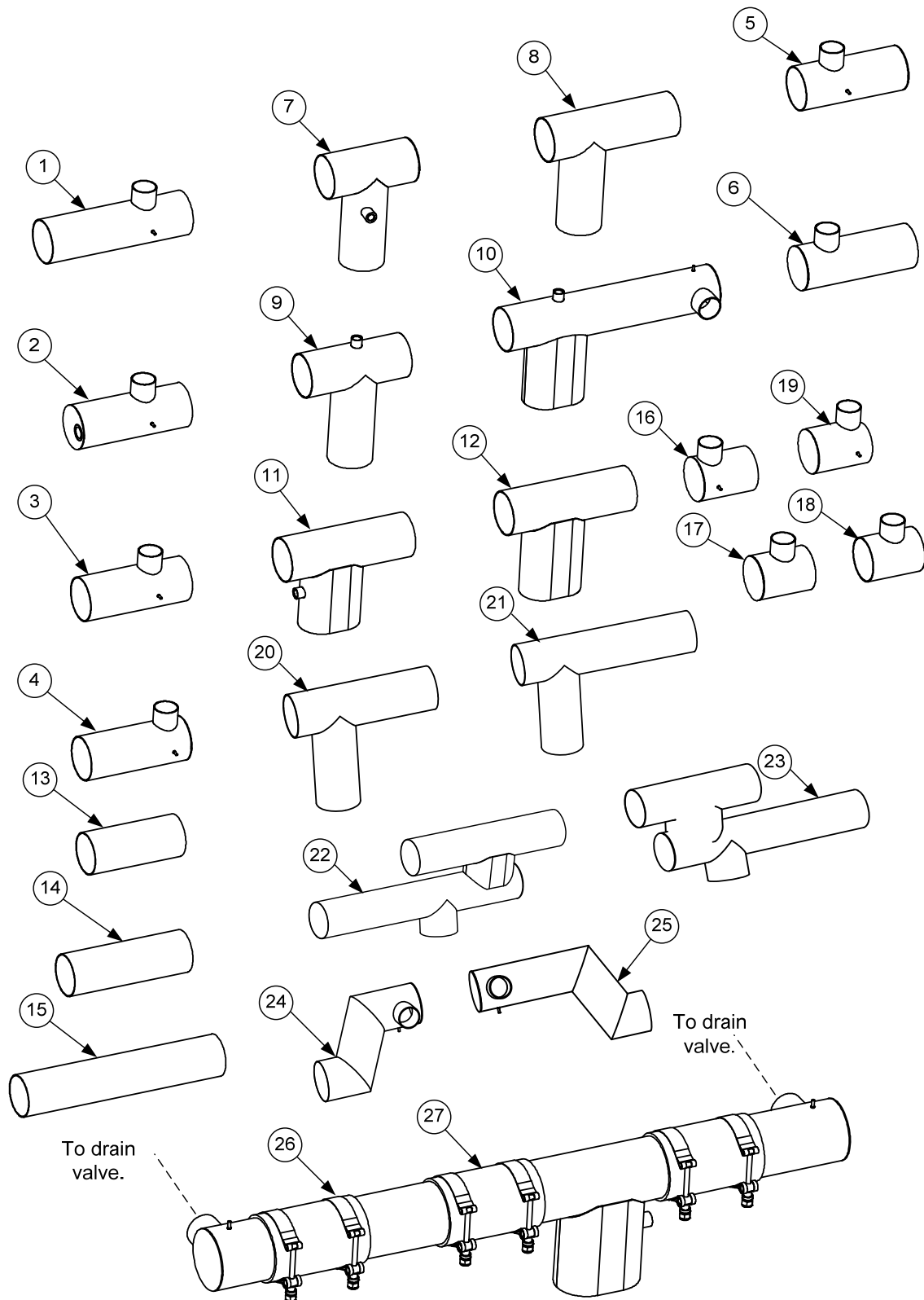

**HIGH EFFICIENCY DECATHLON SERIES GAS FRYERS
CHAPTER 2: PARTS LIST**

2.4.1 3" Drain Manifold Components (cont.)

ITEM	PART #	DESCRIPTION
1	823-5188	Tube, 3" Filter Right, 50/60/80
	823-7664	Tube, 3" Drain Middle BK50 of BK60/50/60
	823-8167	Tube, 3" Drain YSCFHC318
2	823-4681	Tube, 3" Right Drain, 50/60/80
3	823-4682	Tube, 3" Center Drain, 50/60/80
4	812-1764	Tube, 3" Right Drain, KSCFH218G
5	823-6315	Tube, 3" Left, SCFC50
6	823-5911	Tube, 3" Right Drain, Wingstreet
7	812-1998	Spout, 3" 50/60/80
8	812-1901	Spout, 3" CF/BID80
9	812-2006	Spout, 3" Wingstreet
10	812-1908	Spout, 3" KSCFH218G
11	823-6100	Spout, 3" HD65 (with fitting)
12	823-5968	Spout, 3" SCFHD60/63/65
13	200-6751	Tube, 3" Joiner, SCF50
14	200-9365	Tube, 3" Joiner, Drain Filter Right
15	200-6752	Tube, 3" Joiner, SCF50 (for matching cabinet)
	220-6660	Tube, 3" Joiner, Under RAM BK60/50/RAM/60, BK60/RAM/50/60 (19.00")
16	812-1999	Tube, 3" 50/60/80, Short, End Drain
	823-7662	Tube, 3" Left End BK60/50/60 (3.17")
	823-7452	Tube, 3" Left End BK60/50/RAM/60, BK260, BK50 on BK60/RAM/50/60 (4.00")
17	812-2008	Tube, 3" Wingstreet, Short, Mid Drain
18	823-5910	Tube, 3" Wingstreet, Short, Left Drain
19	823-7633	Tube, 3" Right End BK260
20	823-7663	Spout (Dump), 3" BK60/50/60, BK60/50/RAM/60, BK260, BK60/RAM/50/60 (10.06")
21	823-7520	Spout (Dump), 3" BK260 (13.82")
22	823-7667	Spout (Connecting Drain), 3" BK60/RAM/50/60
23	823-7462	Spout (Connecting Drain), 3" BK60/50/RAM/60
24	823-7668	Tube, 3" Left Drop BK60/RAM/50/60
25	823-7461	Tube, 3" Right Drop BK60/50/RAM/60
26	809-0969	Clamp, T-Bolt
27	816-0729	Sleeve, Drain Connection

**HIGH EFFICIENCY DECATHLON SERIES GAS FRYERS
CHAPTER 2: PARTS LIST**

2.4.2 Drain Valve Assemblies

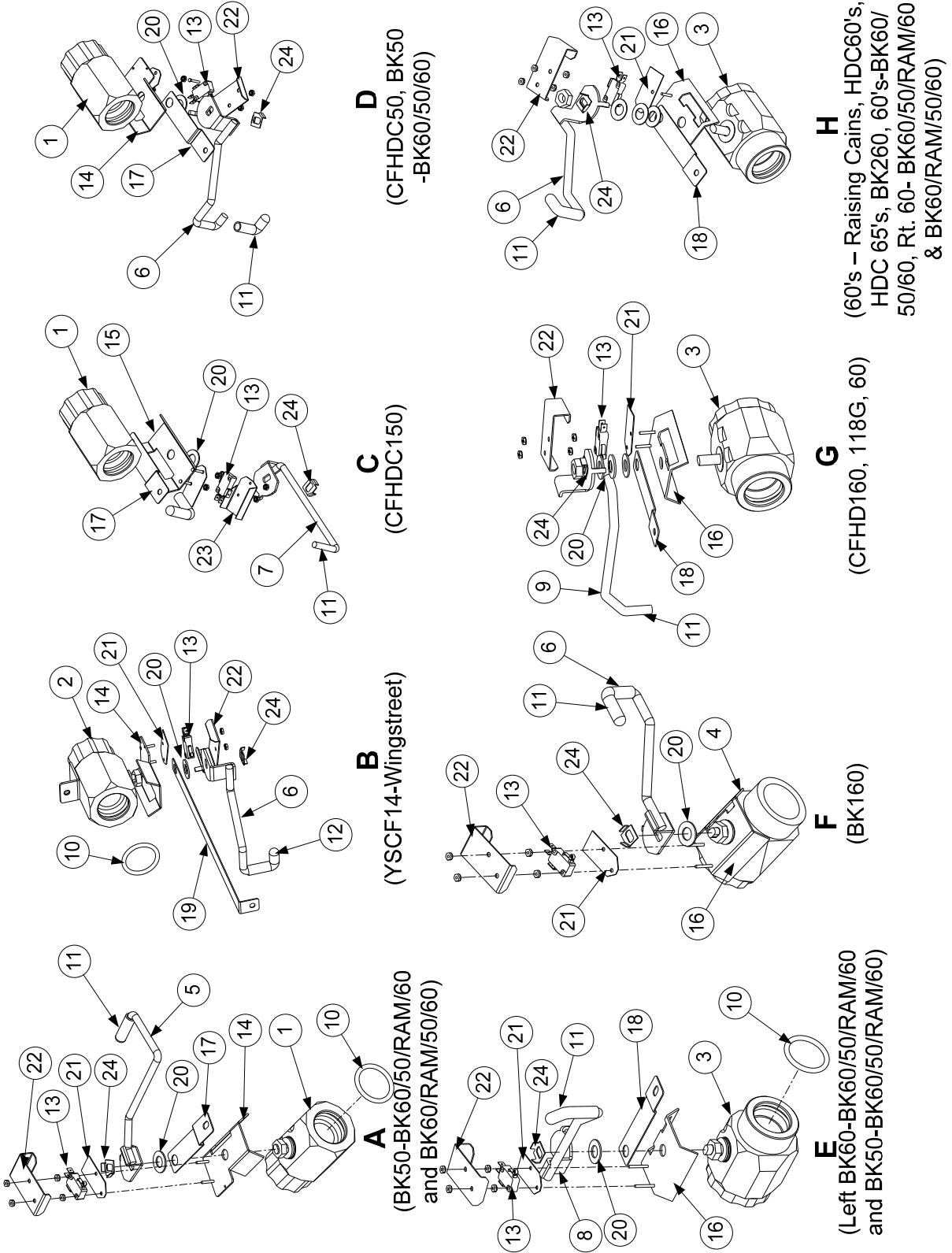

**HIGH EFFICIENCY DECATHLON SERIES GAS FRYERS
CHAPTER 2: PARTS LIST**

2.4.2 Drain Valve Assemblies (cont.)

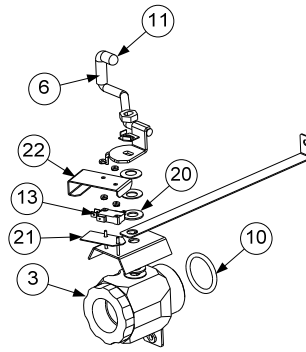

I
(Y/KSCF18)

ITEM	PART #	DESCRIPTION
A	108-1581	Valve Assy, 1 ¼" Drain (BK50 on BK1814-BK60/50/RAM/60 and BK60/RAM/50/60)
B	106-8042	Valve Assy, 1 ¼" Drain (YSCF14-Wingstreet)
C	106-8172	Valve Assy, 1 ¼" Drain (CFHDC150)
D	106-3979	Valve Assy, 1 ¼" Drain (CFHDC50, BK50 on BK1814-BK60/50/60)
E	108-1723	Valve Assy, 1 ½" Drain (Left BK60 on BK1814- BK60/50/RAM/60 and BK60/RAM/50/60)
F	108-1559	Valve Assy, 1 ½" Drain (BK160)
G	106-8401	Valve Assy, 1 ½" Drain (CFHD160, 118G, 60)
H	106-3977	Valve Assy, 1 ½" Drain (60's – Raising Cains, HDC60's, HDC65's, BK260, 60's on BK60/50/60, Right 60 on BK1814- BK60/50/RAM/60 and BK60/RAM/50/60)
*	108-3474	Valve Assy, 1 ½" Drain (GM1814) (use 108-3475 for 1 ¼" drain GM1814)
I	108-0448	Valve Assy, 1 ½" Drain (Y/KSCF 18)
1	810-2784	Valve, 1 ¼" Full Port Drain(includes item # - O-ring)
2	823-5075	Valve , 1 ¼" W/A, Drain Wingstreet
*	810-2126	Valve, 1 ¼" Full Port Drain(includes handle)
3	810-2783	Valve, 1 ½" Full Port Drain (use 823-5053 for Y/KSCF18G)
4	810-2127	Valve, 1 ½" Full Port Drain
5	823-7426	Handle W/A, BK50 Drain Valve
6	823-6262	Handle W/A, HD50/Y/KSCF18G Drain Valve
7	823-6340	Handle W/A, CF150 Drain Valve
8	823-7632	Handle W/A, BK60 Drain Valve
9	823-6424	Handle W/A, Rotating 118G Drain Valve
10	816-0544	O-Ring Seal
11	816-0547	Cap, Vinyl Red
12	816-0549	Cap, Vinyl Blue
13	807-2104	Switch, CE Micro Roller Lever
14	106-6020	Bracket Assy 1 ¼" Drain Valve (use 108-3706 on GM1814)
15	106-8173	Bracket Assy 1 ¼" Drain Valve CF150
16	106-5511	Bracket Assy 1 ½" Drain Valve HE50 (use 108-3701 on GM1814)
17	200-6795	Strap, 1 ¼" Drain Valve Connecting
18	200-6116	Strap, Round Drain Connecting (use 220-5155 for Y/KSCF18)
19	200-8796	Bracket, Drain KSCF218
20	809-0988	Washer, 1.00 OD x .525 ID Teflon
21	816-0220	Insulation, RF Switch
22	220-0143	Guard, BID180 Microswitch Drain
23	901-2348	Cover, DV Safety Switch
24	200-1257	Retainer, Drain Valve Nut
*	812-1717SP	Nipple, Drain (BK160 Non-Filter)

* Not illustrated.

HIGH EFFICIENCY DECATHLON SERIES GAS FRYERS
CHAPTER 2: PARTS LIST

2.5 Oil Return System

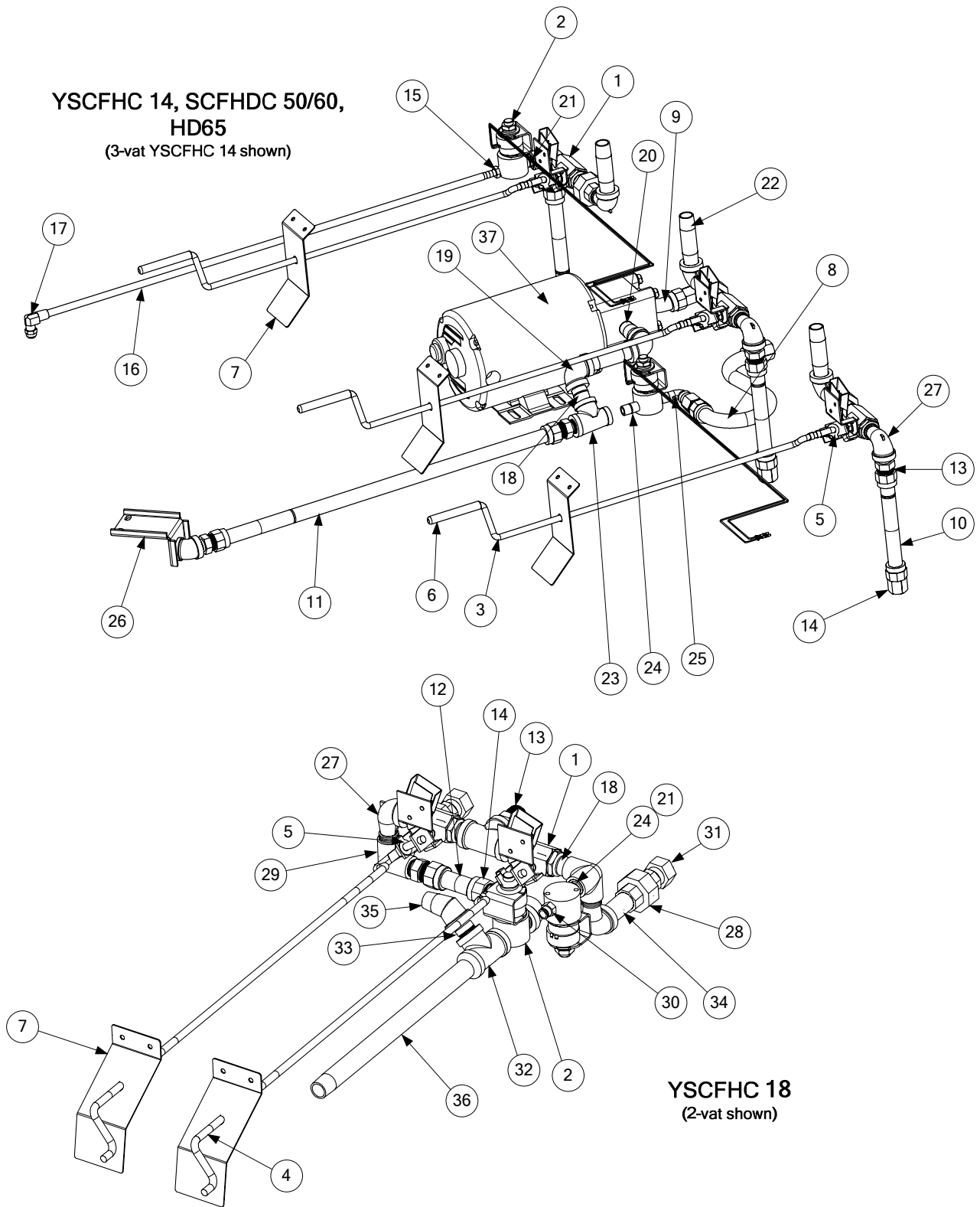

**HIGH EFFICIENCY DECATHLON SERIES GAS FRYERS
CHAPTER 2: PARTS LIST**

2.5 Oil Return System (cont.)

ITEM	PART #	DESCRIPTION
1	106-4006SP	Valve Assembly, 1/2" Oil Return (see Section 2.6 for components)
2	106-7598SP	Valve, Solenoid with Female Pins
3	200-9295	Handle, Oil Return (YSCFC 14, SCFHDC 50/60, HD 65)
4	200-8929	Handle, Oil Return (YSCFC 18)
5	809-0601	Clip, Clevis (to attach handle to Item 1)
6	816-0639	Cap, Red Vinyl (grip for end of handle)
7	210-8790	Bracket, Oil Return Handle
8	810-1057	Flexline, 5/8" OD x 13.00" Long
9	810-1067	Flexline, 5/8" OD x 8.50" Long
10	810-1680	Flexline, 5/8" OD x 6.50" Long
11	810-1400	Flexline, 5/8" OD x 21.00" Long
12	810-1160	Flexline, 5/8" OD x 3.00" Long
13	810-1668	Adapter, Male, 5/8" OD x 1/2"
14	810-1669	Adapter, Female, 7/8" OD x 1/2"
15	810-3199	Fitting, 1/4" NPT x 3/8", Hose Barb
16	812-1838	Tubing, 3/8" OD, 27.00" Long
17	810-1372	Fitting, 1/4" NPT x 3/8" OD, 90° Tube
18	813-0022	Nipple, 1/2" NPT Close, Black Metal
19	813-0062	Elbow, 1/2", 90°, Black Metal
20	813-0298	Nipple, 1/2" x 2.00" NPT, Black Metal
21	813-0304	Bushing, 1/2" x 1/4", Flush, Black Metal
22	813-0460	Nipple, 1/2" x 3.00" NPT, Black Metal
23	813-0530	Tee, Reducing, 1/2" x 1/4" x 1/2"
24	813-0838	Nipple, 1/4" NPT Close, Black Metal
25	813-0919	Elbow, 1/4" Street, 90°, Stainless Steel
26	823-7800	Bracket, Disconnect (Use 823-8001 for 2-Battery) (Use 823-7997 for BK21814/HD50) (Use 823-7998 for BK units with RAM)
27	813-0165	Elbow, 1/2" x 1/2" Street, 90°
28	813-0173	Union, 1/2" NPT, 150#
29	813-0331	Elbow with Side Outlet, 1/2" NPT
30	810-2492	Fitting, Straight, Quick Connect
31	810-3160	Adapter, 1/2" NPT x 15/16"
32	813-0003	Tee, 1/2" x 1/2" x 1/2", Black Metal
33	813-0087	Nipple, 1/2" x 1.50" NPT
34	813-0265	Nipple, 1/2" x 2.50" NPT, Black Metal
35	813-0342	Elbow, Street, 45°, 1/2" NPT
36	813-0515	Nipple, 1/2" x 12.00" NPT
37	▶▶▶	See Additional Oil Return Components, Section 2.6

HIGH EFFICIENCY DECATHLON SERIES GAS FRYERS
CHAPTER 2: PARTS LIST

2.6 Additional Oil Return Components

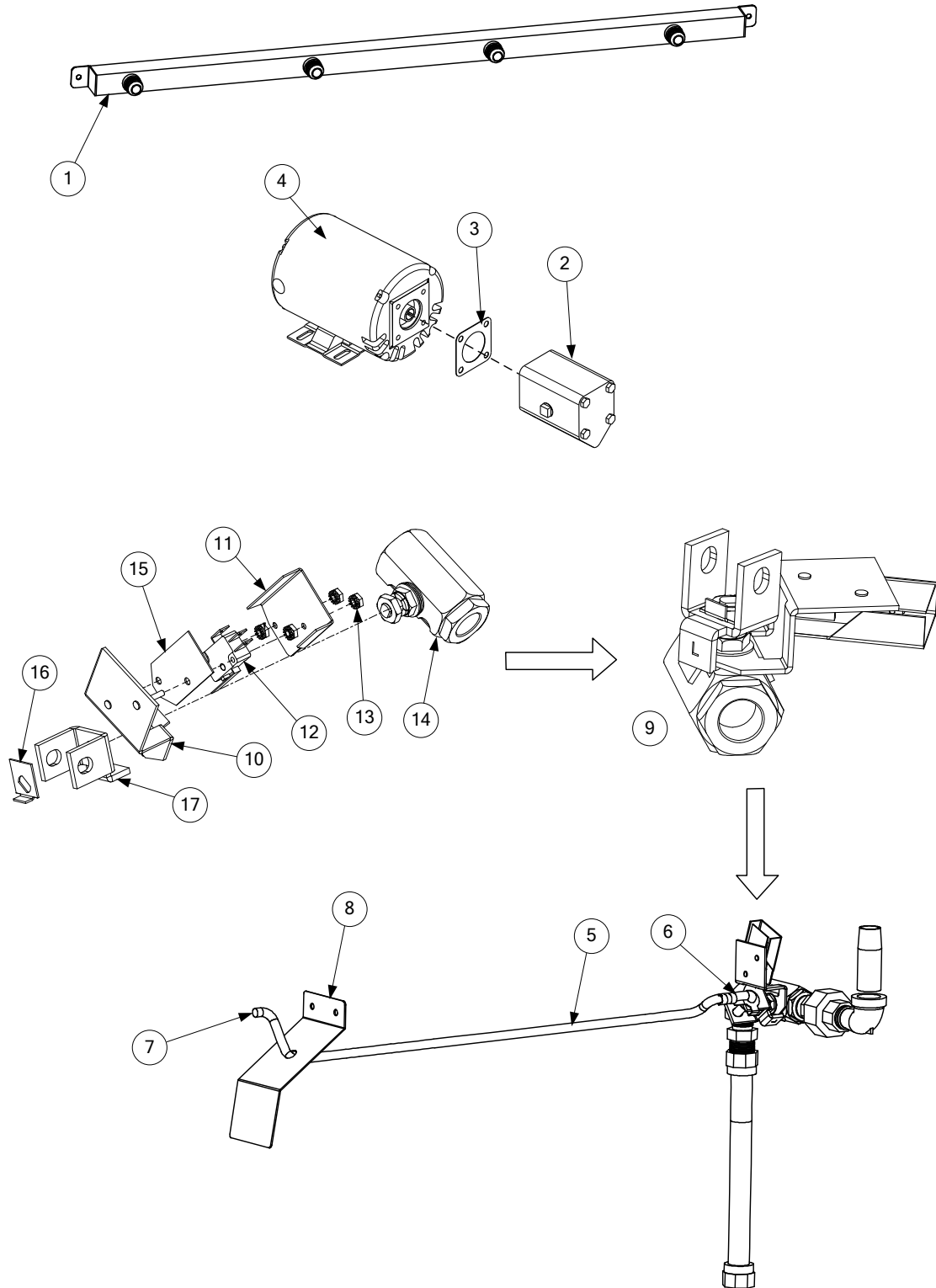

**HIGH EFFICIENCY DECATHLON SERIES GAS FRYERS
CHAPTER 2: PARTS LIST**

2.6 Additional Oil Return Components (cont.)

ITEM	PART #	DESCRIPTION
1		Oil Return Manifold
	810-3113	314/350
	810-3117	214/250
	810-3118	260/460/665/63/218G
	810-3120	460
	810-3121	360/318G
	810-3734	BK1814 -60/50/60
	810-3555	BK1814 – 60/50/RAM/60 or 60/RAM/50/60
	810-3170	550
2		Pump
	810-3346	4 GPM, Viking
	826-1264	4 GPM, 2-piece
	810-3347	8 GPM, Viking
*	807-11973	Viking Pump Seal Kit
3	816-0093	Gasket (Pump/Motor) (included with motor)
4		Motor and Gasket Kit
	826-1785	100V 50/60Hz
	826-1712	115V 50/60Hz
	826-1270	230V 50/60Hz
5	200-8929	Handle, Oil Return (use 200-9295 BK1814)
6	809-0601	Clip, Clevis, Rod End
7	816-0638	Cap, Vinyl Yellow ⁵ / ₁₆ " x 3"
*	816-0637	Cap, Vinyl Blue ⁵ / ₁₆ " x 3"
*	816-0639	Cap, Vinyl Red ⁵ / ₁₆ " x 3"
8	210-8790	Bracket, Oil Return Handle (use 230-6575 BK60/50) (use 230-7305 for 318G)
9	106-4006SP	Valve Assembly, Oil Return
10	106-3962	Bracket, ½" Switch Flush
11	220-2459	Cover, Safety Switch ½"
12	807-2103	Microswitch, Straight Lever
13	826-1366	Nut, 4-40 Keps Hex (with External Teeth)
14	810-0278	Valve, ½" Ball
15	816-0220	Insulation, Microswitch
16	900-2935	Retainer, Oil Return Valve
17	901-2772	Handle Bracket, Valve

* Not illustrated.

**HIGH EFFICIENCY DECATHLON SERIES GAS FRYERS
CHAPTER 2: PARTS LIST**

2.7 Oil Disposal Plumbing (Popeye's and Church's)

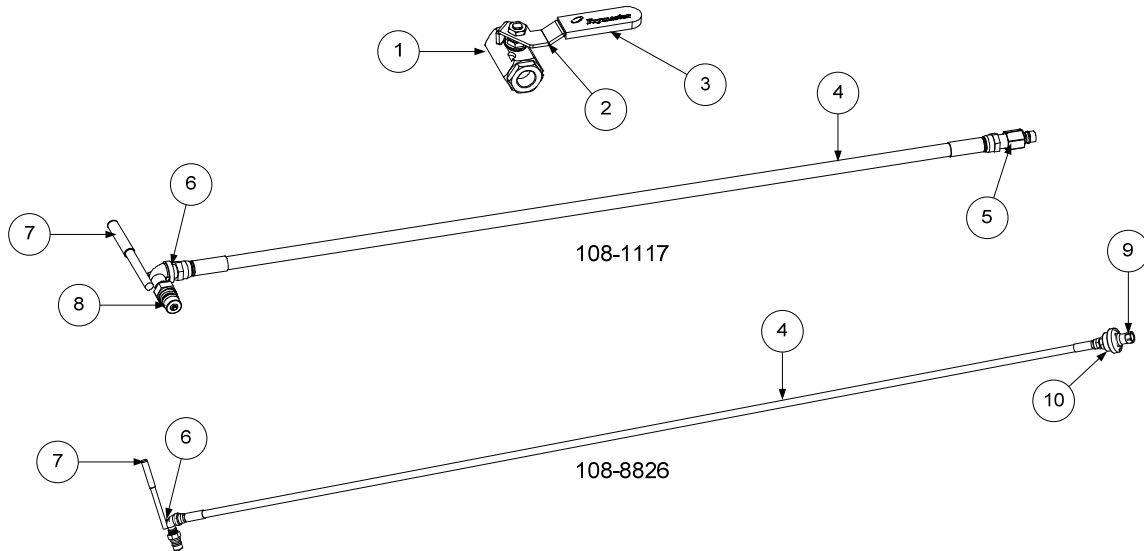

ITEM	PART #	DESCRIPTION
	108-1121	Valve, Oil Disposal
1	810-0278	Valve
2	900-5953	Handle
3	814-0047	Sleeve
	108-1117	Oil Disposal Assembly
4	810-2379	Hose, 107.5", 1/2" x 1/2"
5	813-0699	Nipple, Snaptite, 1/2"
6	823-7153	Handle
7	816-0631	Sleeve/Cap, Handle
8	810-0487	Coupling, Male
	108-2226	Oil Disposal Assembly
9	810-0487	Coupling Male
10	810-0490	Quick Disconnect 1/2" Female

**HIGH EFFICIENCY DECATHLON SERIES GAS FRYERS
CHAPTER 2: PARTS LIST**

2.8 Oil Return Wand

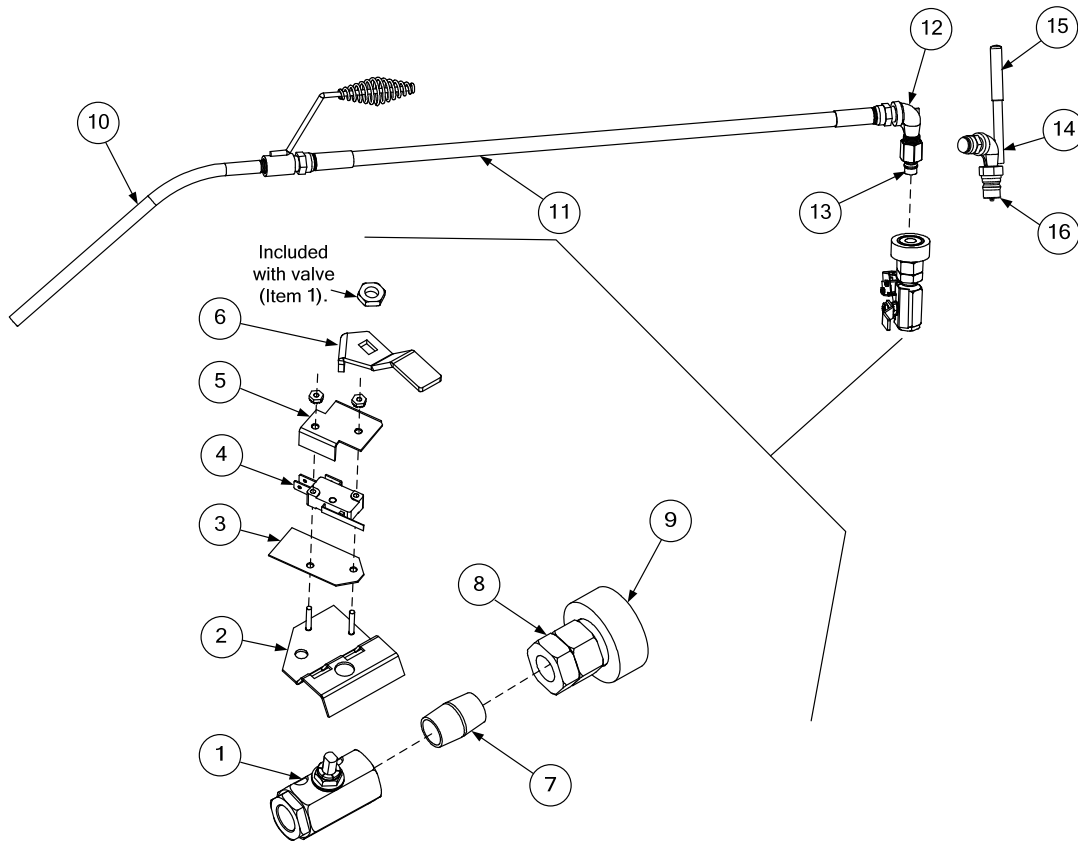

ITEM	PART #	DESCRIPTION
	106-3997	Wand Valve Assembly
1	810-0278	Valve, ½" Ball
2	806-9128	Bracket, Microswitch
3	816-0220	Insulation, Microswitch
4	807-2103	Microswitch, CE Micro-roller, Straight Lever
5	900-2849	Cover, Microswitch
6	900-2839	Handle, Wand Valve
7	813-0022	Nipple, ½" x Close NPT
8	810-2283	Quick Disconnect, 1-¾" (#VHC8-8F)
9	810-2282	Collar, Quick Disconnect, 1-¾" Hole
	106-2568SP	Wand Hose Assembly (Generic)
	108-0528	Wand Hose Assembly (Church's, Popeye's, Raising Cane's)
10	106-1454SP	Nozzle Assembly, Hose with Handle (part of 106-2568 and 108-0528)
11	810-1434	Hose Assembly, Standard, 5 ½ feet (part of 106-2568 and 108-0528)
12	813-0165	Elbow, Street, ½" NPT, 90° (part of 106-2568)
13	813-0699	Nipple, Snaptite, ½" (#PHN8-8F) (part of 106-2568)
14	823-7153	Handle, Wash Down Hose (part of 108-0528)
15	816-0631	Cap, Red Vinyl, ½" x 3" (part of 108-0528)
16	810-0487	Coupling, Male (part of 108-0528)
*	813-0368	Nipple, ½" NPT x 16" Black Metal
*	813-0345	Elbow, ½" NPT, 45° Black Metal
*	813-0087	Nipple, ½" NPT x 1.5" Black Metal
*	810-2043	Clamp, Pipe, ½" (Jiffy H-40)
*	230-4773	Bracket, Side

* Not illustrated.

**HIGH EFFICIENCY DECATHLON SERIES GAS FRYERS
CHAPTER 2: PARTS LIST**

2.9 Over-the-Top Oil Return System

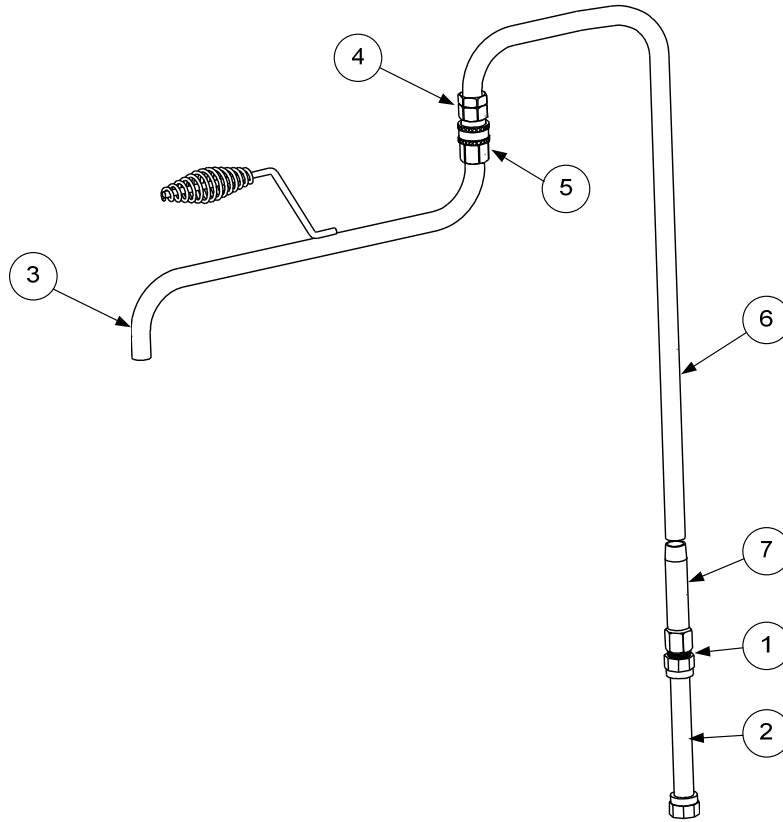

ITEM	PART #	DESCRIPTION
1	810-1669	Adapter, Female $\frac{7}{8}$ " O.D. x $\frac{1}{2}$ "
2	810-1680	Flexline, $\frac{5}{8}$ " I.D. x 6.50" Long
3	810-2513	Tubing, Faucet Upper
4	810-2699	Coupling, Quick Disconnect, Snaptite
5	810-2700	Nipple, Quick Disconnect, Snaptite
6	810-3234	Tubing, Faucet Rear
7	813-0093	Nipple, $\frac{1}{2}$ " x 4" NPT BM

**HIGH EFFICIENCY DECATHLON SERIES GAS FRYERS
CHAPTER 2: PARTS LIST**

2.10 Filtration Components

2.10.1 Filtration Components; SCFHDC50 Series and BK1814 Fryers

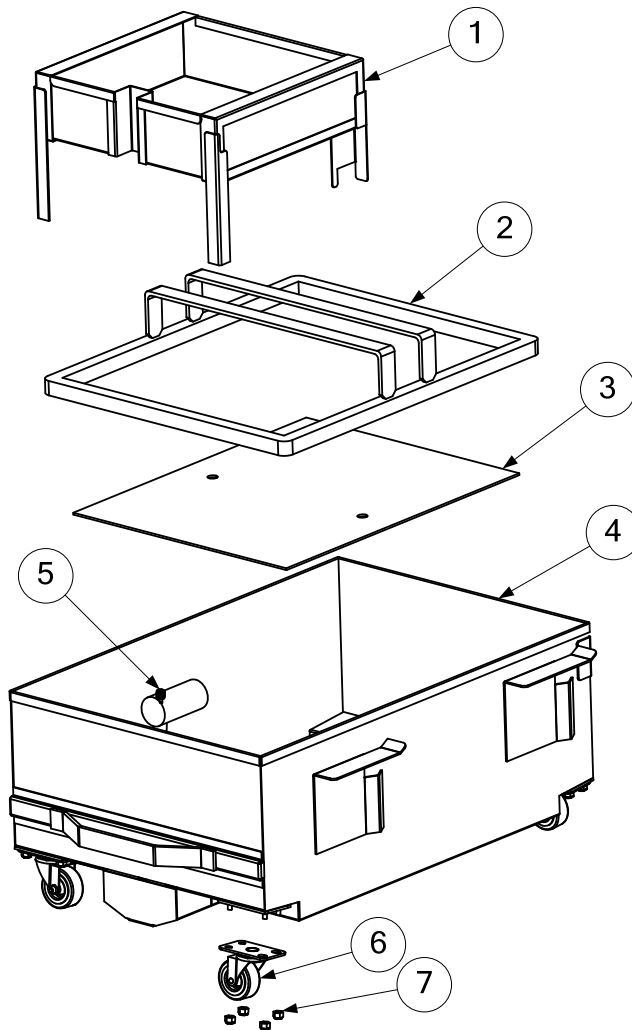

ITEM	PART #	DESCRIPTION
1	823-6366	Basket, Crumb
	823-7425	Basket, Crumb (BK1814)
2	810-3541	Ring, Hold-down
3	200-8003	Screen, Sana Grid
4	823-7294	Pan, Filter
5	813-0568	Plug, 1/8" NPT Socket-Head Pipe
6	810-2805	Caster, 2" Filter Pan
7	809-0823	Nut, Nylock, 1/4-20
*	823-6603	Lid (mounted in frame)
*	823-7652	Lid (mounted in frame) BK60/50/RAM/60, BK260
*	823-7418	Lid (mounted in frame) BK60/50/60
*	823-7627	Lid (mounted in frame) BK50/RAM/50/60

* Not illustrated.

**HIGH EFFICIENCY DECATHLON SERIES GAS FRYERS
CHAPTER 2: PARTS LIST**

2.10.2 Filtration Components; SCFHDC60 Series Fryers

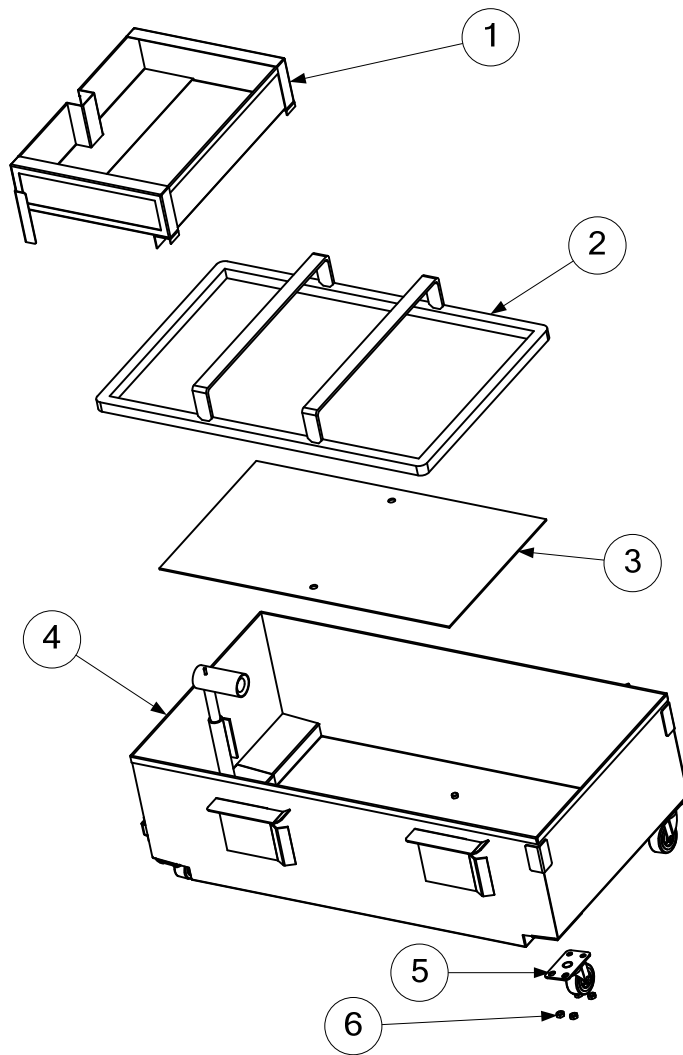

ITEM	PART #	DESCRIPTION
1	823-6018	Basket, Crumb
*	823-7110	Basket, Crumb (Raising Cane's)
2	810-3540	Ring, Hold-down
3	200-5726	Screen, Sana Grid
4	823-6338	Pan, Filter
5	810-2805	Caster, 2" Filter Pan
6	809-0070	Nut, 1/4-20 Hex, S/S
*	823-6403	Lid (mounted in frame)

* Not illustrated.

**HIGH EFFICIENCY DECATHLON SERIES GAS FRYERS
CHAPTER 2: PARTS LIST**

2.10.3 Filtration Components; Y/K/SCF/C/HC218 and 63 Series Fryers

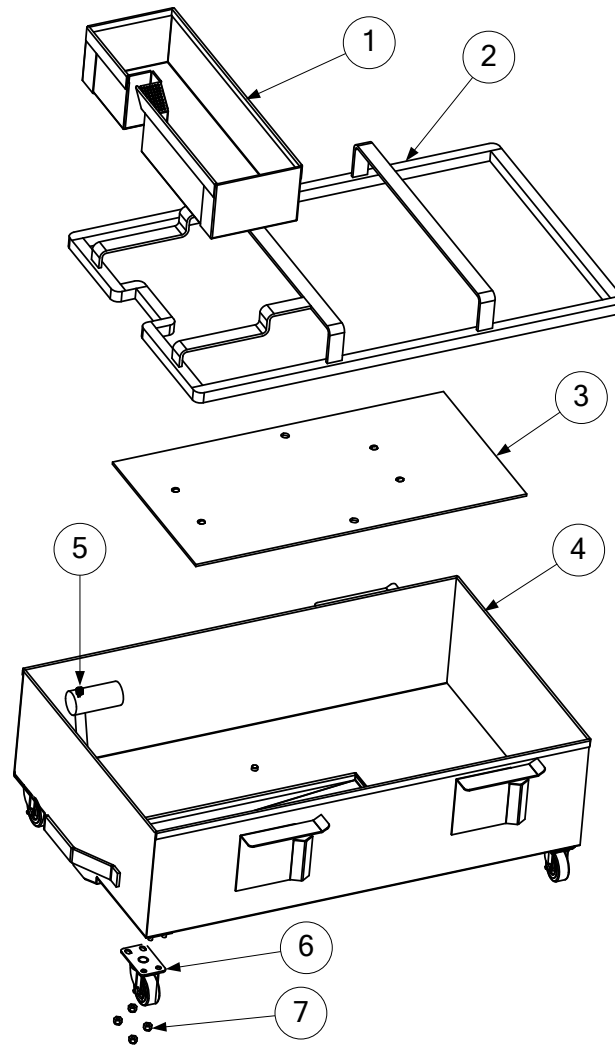

ITEM	PART #	DESCRIPTION
1	823-6172	Basket, Crumb
2	810-3195	Ring, Hold-down
3	106-7330SP	Screen Assembly, Filter
4	823-7534	Pan, Filter
5	813-0568	Plug, 1/8" NPT, Socket-Head
6	810-2805	Caster, 2" Filter Pan
7	809-0823	Nut, Nylock, 1/4-20
*	823-6507	Lid (mounted in frame)

* Not illustrated.

**HIGH EFFICIENCY DECATHLON SERIES GAS FRYERS
CHAPTER 2: PARTS LIST**

2.10.4 Filtration Components; Y/KSCF/C/HC218 Export (India) Series Fryers prior to May 2010

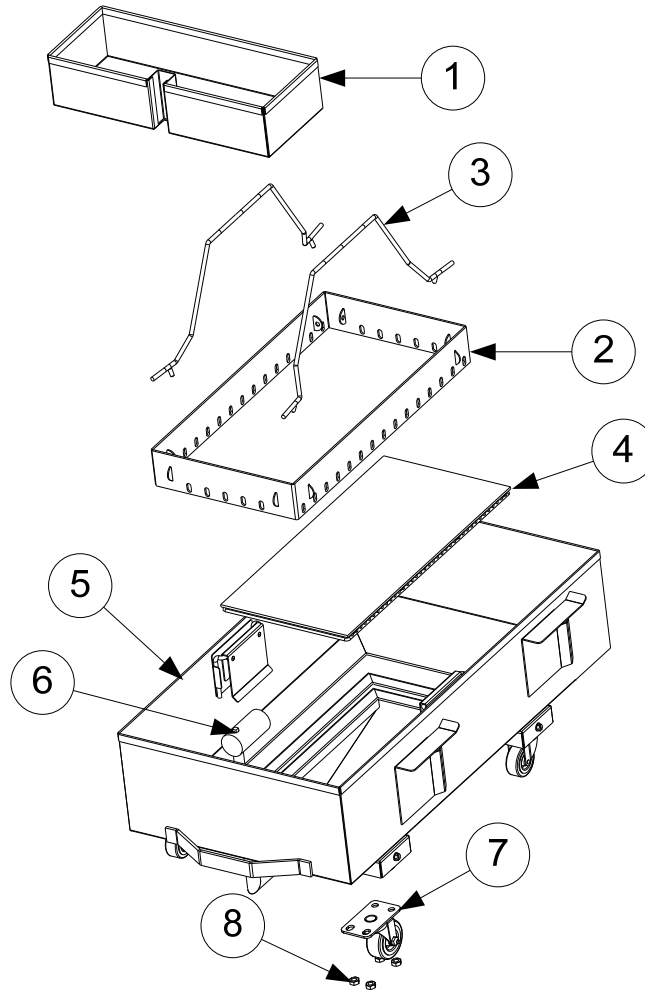

ITEM	PART #	DESCRIPTION
1	823-5427	Basket, Crumb
2	823-4470	Ring, Hold-down
3	823-4471	Handle Hold Down Ring
4	106-7912SP	Screen Assembly, Filter
5	108-1022SP	Pan, Filter
6	813-0679	Plug, 1/8" SS NPT, Sq-Head
7	810-2805	Caster, 2" Filter Pan
8	809-0823	Nut, Nylock, 1/4-20
*	813-0704	Plug, 3/8" SS Hex Head
*	823-6911	Lid (mounted in frame)

* Not illustrated.

**HIGH EFFICIENCY DECATHLON SERIES GAS FRYERS
CHAPTER 2: PARTS LIST**

2.10.5 Filtration Components; Y/KSCF/C/HC218 Export (India) Series Fryers after May 2010

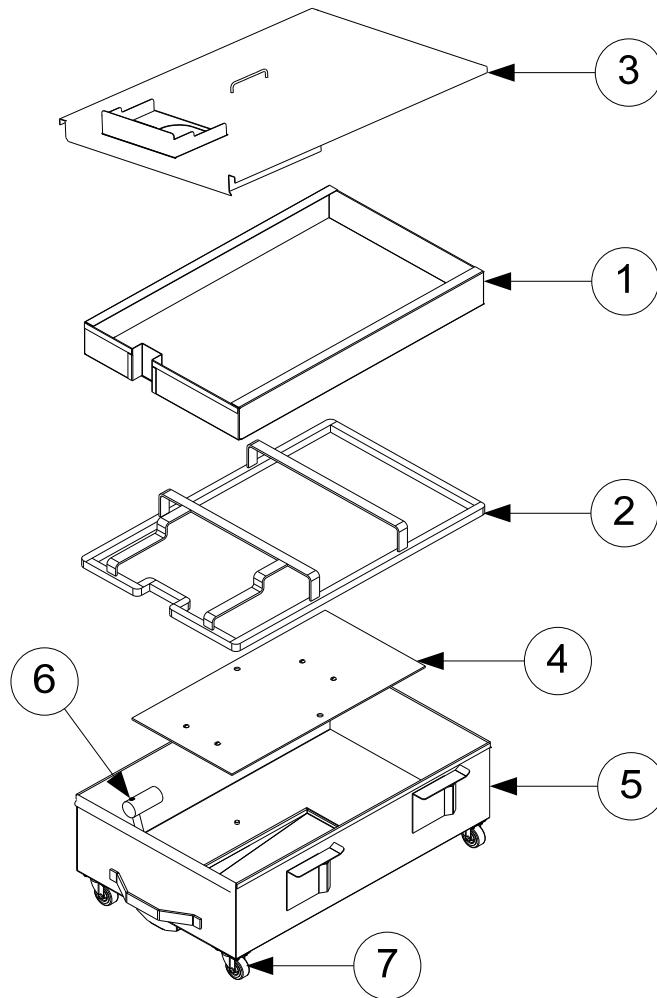

ITEM	PART #	DESCRIPTION
1	823-7904	Basket, Crumb
2	810-3195	Ring, Hold-down
3	823-7834	Lid
4	106-7330SP	Screen Assembly, Filter
5	823-7534	Pan, Filter
6	813-0568	Plug, 1/8" SS NPT, Sq-Head
7	810-2805	Caster, 2" Filter Pan
*	809-0823	Nut, Nylock, 1/4-20

* Not illustrated.

**HIGH EFFICIENCY DECATHLON SERIES GAS FRYERS
CHAPTER 2: PARTS LIST**

2.10.6 Filtration Components; 65 Series Fryers (Filter Paper Option)

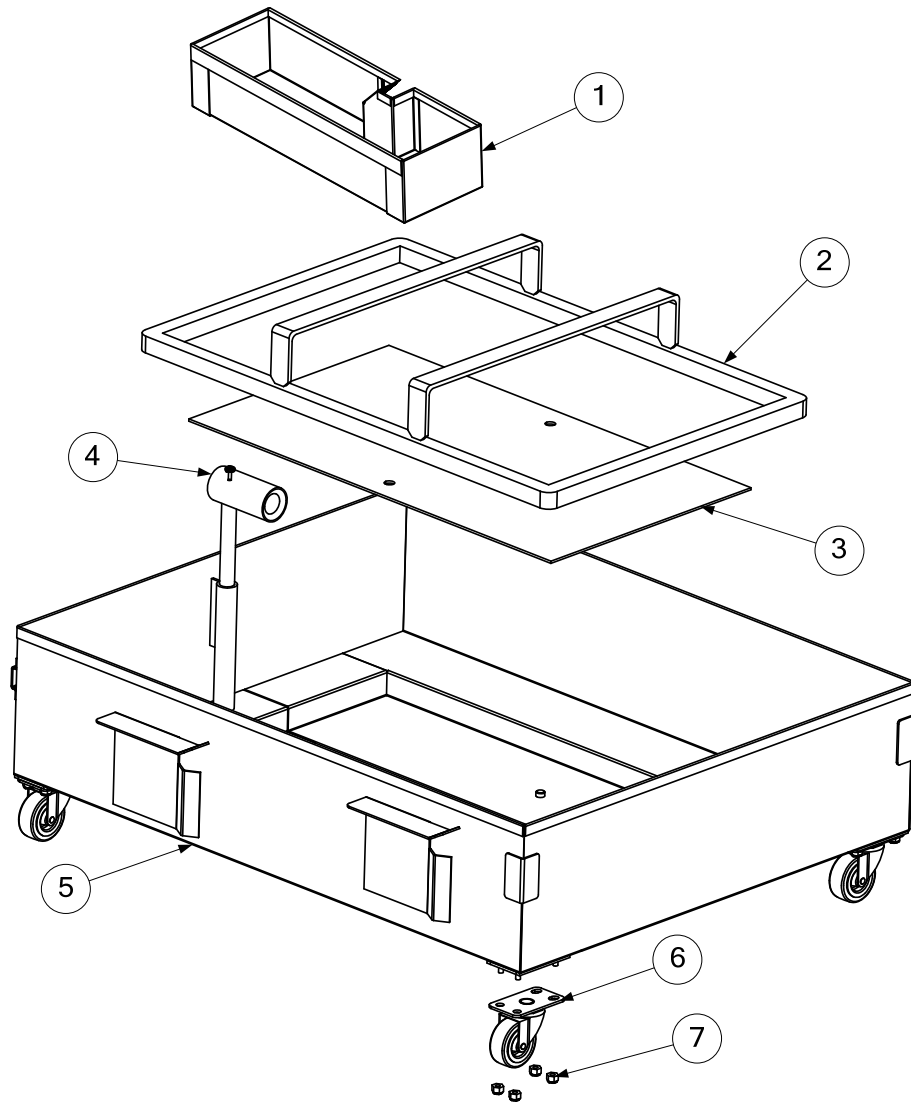

ITEM	PART #	DESCRIPTION
1	823-6018	Basket, Crumb
2	810-3540	Ring, Hold-down
3	200-5726	Screen, Sana Grid
4	813-0568	Plug, 1/8" NPT, Socket-Head Pipe
5	823-6304	Pan, Filter
6	810-2805	Caster, 2" Filter Pan
7	809-0823	Nut, Nylock, 1/4-20
*	823-5857	Lid (mounted in frame)

* Not Illustrated.

**HIGH EFFICIENCY DECATHLON SERIES GAS FRYERS
CHAPTER 2: PARTS LIST**

2.10.7 Filtration Components; 65 Series Fryers (Filter Leaf Option)

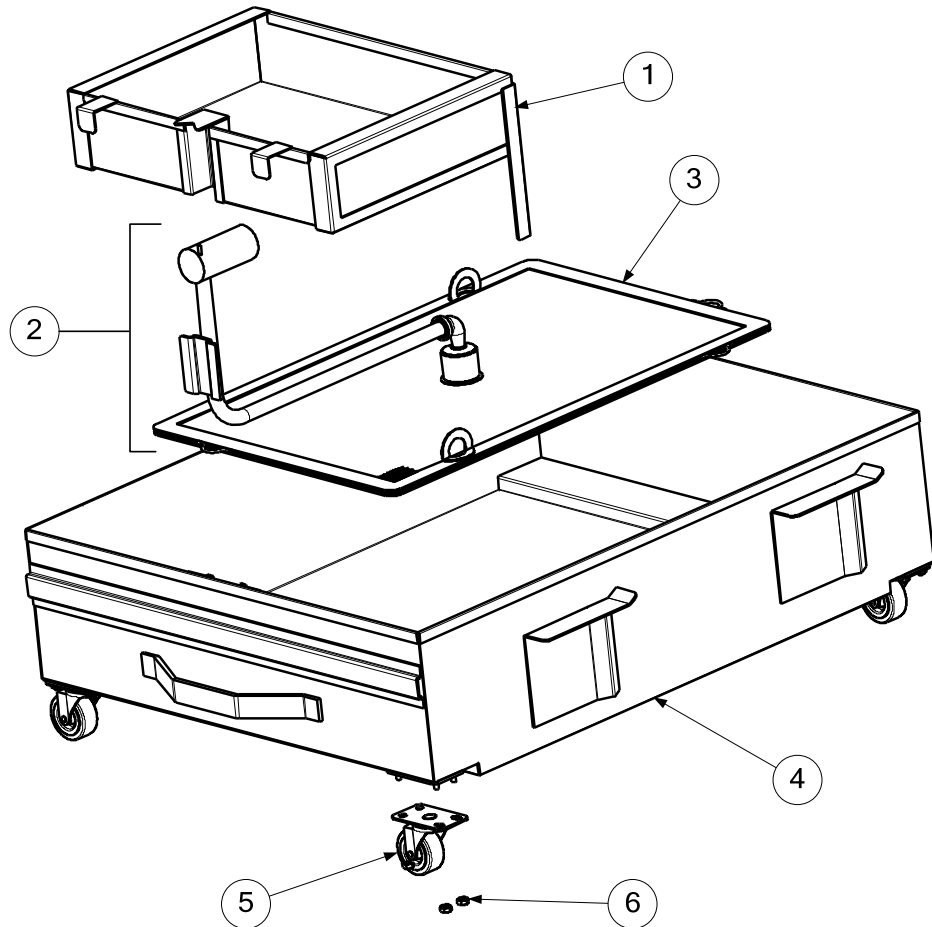

ITEM	PART #	DESCRIPTION
1	823-5851	Basket, Crumb
2	106-6466SP	Filter Leaf with Suction Tube Assembly
3	106-8399	Filter Leaf (screen only)
4	823-5258SP	Filter Pan
5	810-2805	Caster, 2"
6	809-0070	Nut, 1/4"-20 Hex
*	823-5857	Lid (mounted in frame)

* Not Illustrated.

**HIGH EFFICIENCY DECATHLON SERIES GAS FRYERS
CHAPTER 2: PARTS LIST**

2.10.8 Filtration Components; 65 Series Fryers (Popeye's / Church's Filter Paper Option)

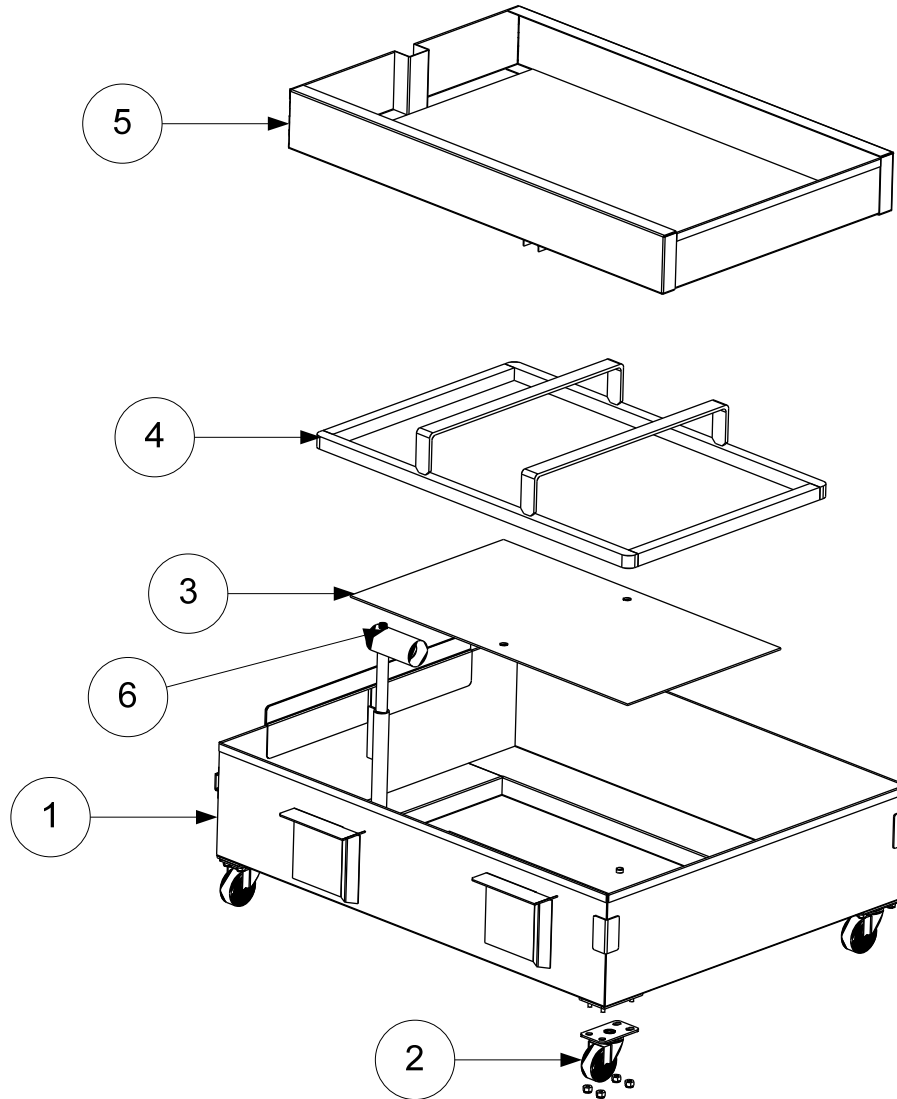

ITEM	PART #	DESCRIPTION
1	823-7769SP	Filter Pan SCFHD65
2	810-2805	Caster, 2"
3	200-5726	Screen, Sana Grid UFF60
4	810-3540	Ring, Hold-down UFF60
5	823-8659	Basket, Crumb 65
6	813-0568	Pipe Plug 1/8 NPT Socket Head

HIGH EFFICIENCY DECATHLON SERIES GAS FRYERS
CHAPTER 2: PARTS LIST

2.11 Basket Lift Components

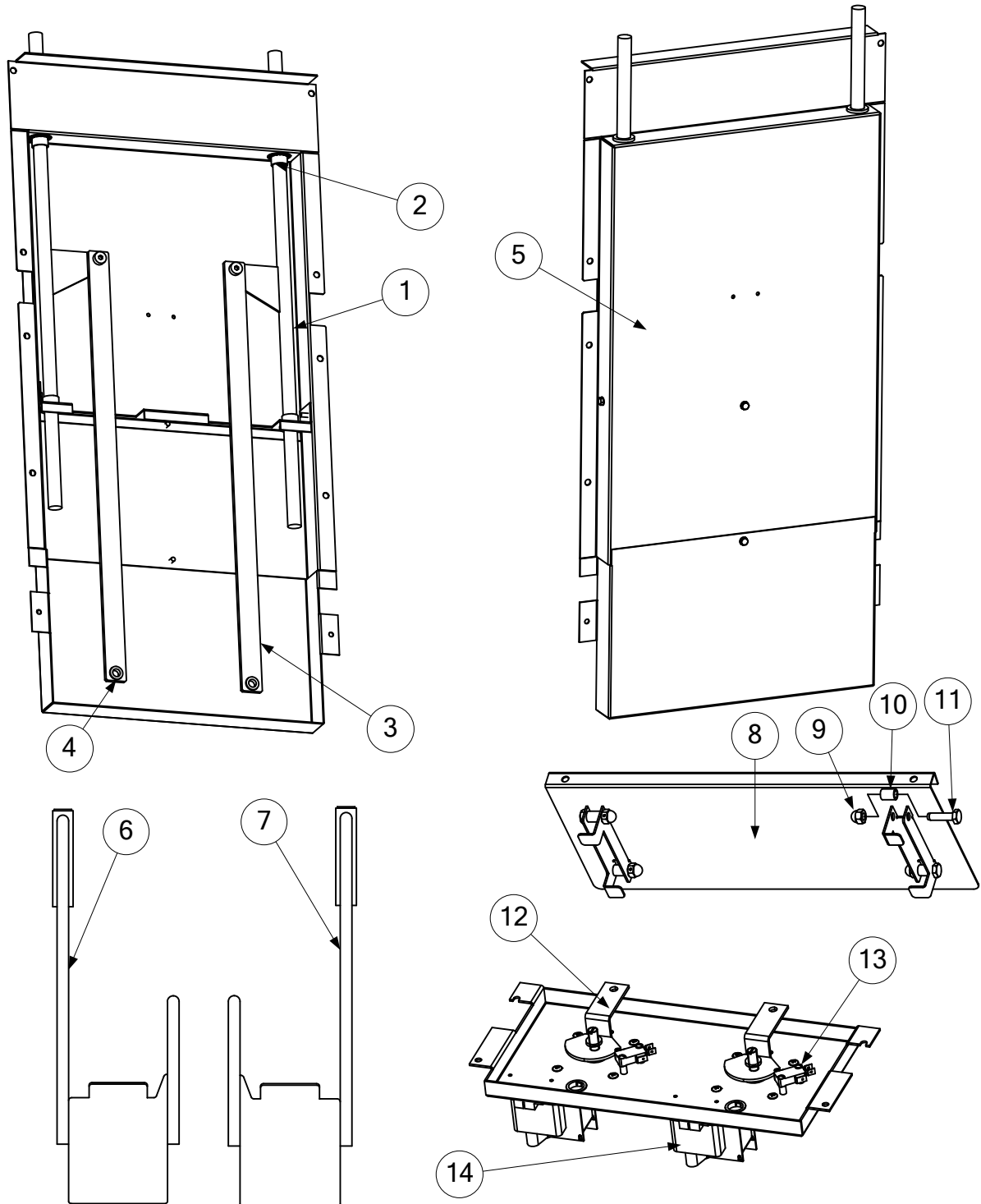

**HIGH EFFICIENCY DECATHLON SERIES GAS FRYERS
CHAPTER 2: PARTS LIST**

2.11 Basket Lift Components (cont.)

ITEM	PART #	DESCRIPTION
HDC50 Models (106-7702)		
1	823-3625	Lift Rod
2	813-0035	Bushing, Bronze
3	200-2069	Lift Bar
4	210-2140	Bushing, 3/8" x 1/2"
5	824-1783	Back, Upper
*	824-0991	Back, Lower
6	823-6871	Lift Assembly, Left
7	823-6870	Lift Assembly, Right
8	106-8370	Lift Guide Assembly
9	809-0990	Nut, Low Crown, 1/4" x 20"
10	810-3307	Roller
11	809-1018	Bolt, 1/4" x 20" x 1" S/S
12	823-3626	Switch, Limit Cam
13	807-2104	Microswitch, Micro Roller Lever
14	807-0107	Gear Motor, 120V
HDC60/63 Models (106-8058)		
1	823-6309	Lift Rod
2	813-0035	Bushing, Bronze
3	220-3060	Lift Bar
4	810-2140	Bushing, 3/8" x 1/2"
5	824-1834	Back
6	823-6588	Lift Assembly, Left
7	823-6589	Lift Assembly, Right
8	106-8368	Lift Guide Assembly
9	809-0990	Nut, Low Crown, 1/4" x 20"
10	810-3307	Roller
11	809-1018	Bolt, 1/4" x 20" x 1" S/S
12	823-6312	Switch, Limit Cam (HD63 Red Robin)
*	823-3626	Switch, Limit Cam (HD60 Red Robin)
13	807-2104	Microswitch, Micro Roller Lever
14	807-0107	Gear Motor, 120V
*	106-1870SP	Lift Assembly, D60/63 Basket (Red Robin)
*	823-3625	Lift Assembly, Basket (Red Robin)
*	230-3069	Arm, Basket Lift Cam (Red Robin)
*	809-1019	Bolt, 3/8" x 5/16" Shoulder (Red Robin)

*Not illustrated.

HIGH EFFICIENCY DECATHLON SERIES GAS FRYERS
CHAPTER 2: PARTS LIST

2.12 Accessories

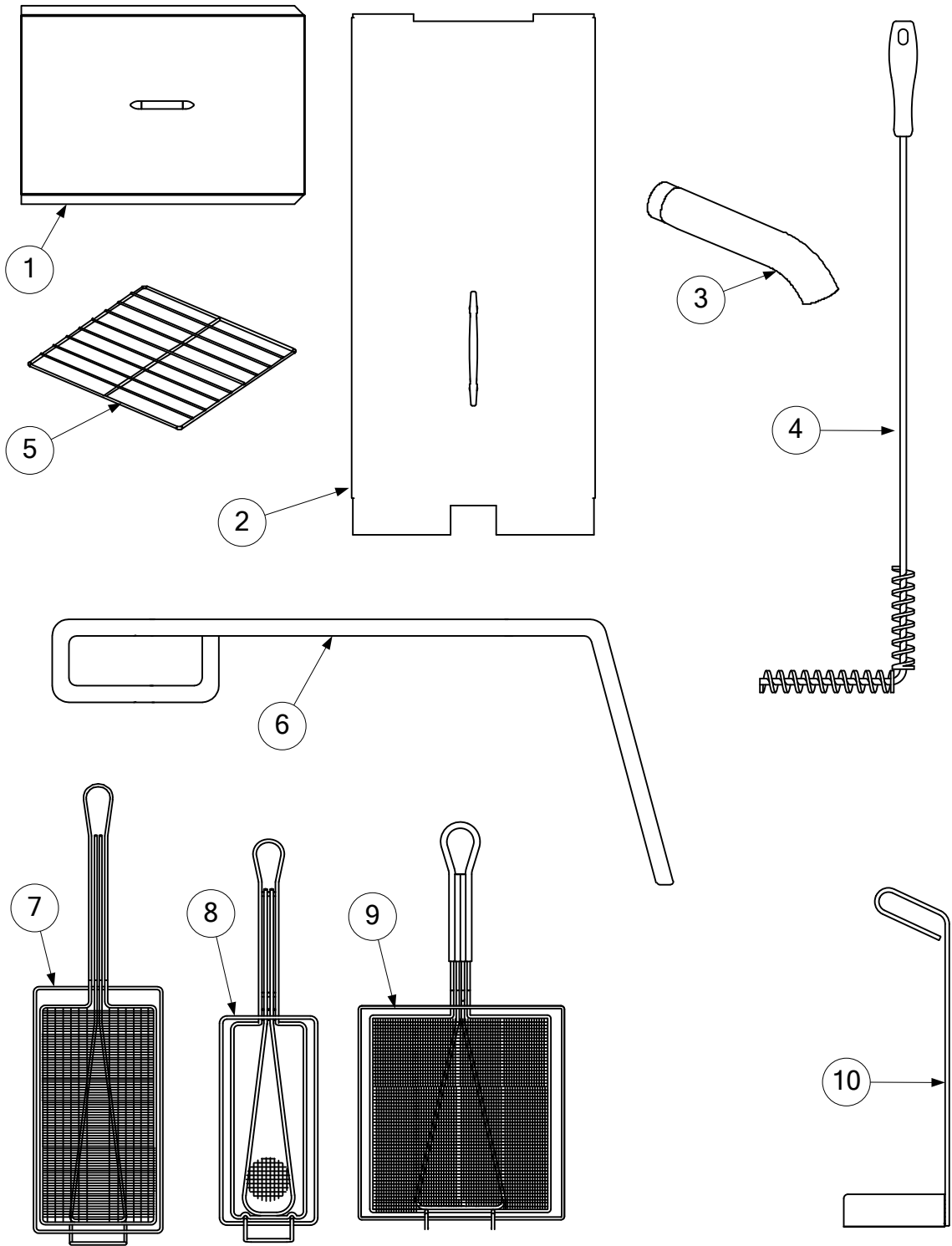

**HIGH EFFICIENCY DECATHLON SERIES GAS FRYERS
CHAPTER 2: PARTS LIST**

2.12 Accessories (cont.)

ITEM	PART #	DESCRIPTION
1	106-1637SP	Cover, Full-vat (HD50/BK50)
2	106-2585SP	Cover, Split-vat (HD60)
*	106-1447SP	Cover, Full-vat (HD60)
*	108-1872	Cover, Full-vat (BK60)
*	106-1479SP	Cover, Full-vat (Raising Cane's)
*	106-2897SP	Cover (FPHD65/Church's)
*	106-6494	Cover (HD56)
*	810-0180	Handle, Vat Cover (Full- and Split-)
3	812-1226SP	Drain Nipple, extension 1 ¼"
*	812-1717SP	Drain Nipple, extension 1 ½"
4	803-0278	L-shaped Brush
5	803-0277	Grid Assembly
*	810-2552	Mesh grid assembly
*	810-2235	Grid assembly, rack
6	803-0197	Fryer's Friend
7	803-0304	Basket, Twin (KFC)
*	803-0392	Basket, Twin (Raising Cane's)
8	803-0271	Basket, Twin
9	803-0099	Basket, Full
*	803-0337	Basket, 6" x 8 ¾" x 16 ¾"
10	823-3938	Crumb Scoop
*	106-2631SP	Sediment Tray
*	823-3947	Chicken Crisper
*	803-0293	Gloves (pair)
*	824-2043	Workshelf, 260 (Raising Cane's)
*	824-2044	Workshelf, 360 (Raising Cane's)
*	824-1992	Workshelf, 460 (Raising Cane's)

* Not illustrated.

2.13 Fasteners (Screws, Nuts, Bolts)

ITEM	PART #	DESCRIPTION
*	809-0417	Nut, Flange ¼-20 Serrated
*	809-0766	Nut, Keps 10-32 SS Hex
*	826-1366	Nut, 4-40 Keps Hex (with External Teeth, pkg. of 25)
*	809-0247	Nut, 8-32 Hex Keps (Zinc Plated)
*	809-0863	Nut, Nylock, 5/16"-18 Hex
*	809-0169	Screw, #12 x ¾" Hex Washer Slotted Head
*	809-0428	Screw, ¼-20 x ½" Hex Head
*	826-1389	Screw, ¼-20 x ¾" Hex Head (pkg. of 10)
*	809-0918	Screw, 10-24 x ½" Slotted Head
*	809-0845	Screw, 10-32 x ⅜" Hex Slotted Head
*	809-0846	Screw, 4-40 x 1"
*	809-0918	Screw, 10-24 x ½" Round Slotted Head
*	809-0167	Screw, Sheet Metal 10 A x ⅝" B
*	809-0475	Screw, #10 x ⅜" Hex Washer Head
*	809-1019	Screw, .375 x ½" Shoulder
*	826-1379	Screw, #10 x ½" Phillips Truss Head (pkg. of 10)
*	809-0962	Screw, 8-32 x 1-⅝" Phillips Truss Head
*	809-0191	Washer, ¼" Spring-lock

* Not illustrated.

HIGH EFFICIENCY DECATHLON SERIES GAS FRYERS CHAPTER 2: PARTS LIST

2.14 Flexlines

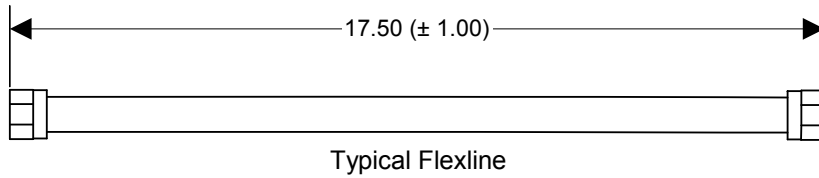

LENGTH	PART NUMBER
3.0-inch	810-1160
4.5-inch	810-1339
5.0-inch	810-1159
6.5-inch	810-1680
8.5-inch	810-1067
9.5-inch	810-1043
11.5-inch	810-1055

LENGTH	PART NUMBER
13.0-inch	810-1057
17.5-inch	810-1369
21.0-inch	810-1400
21.5-inch	810-1068
29.5-inch	810-1069
53.5-inch	810-1056

Flexlines come with a $\frac{7}{8}$ -inch female fitting on each end. Adapters (listed below) are required to fit them to standard $\frac{1}{2}$ -inch NPT pipe nipples of fittings. Add $\frac{3}{4}$ -inch to the overall length of the flexline for each adapter used.

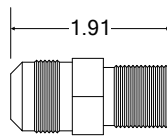

810-1668

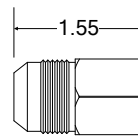

810-1669

NOTE: Be aware that these are *flexible metal* lines. Consequently, the length of a particular line can vary as much as $\pm \frac{1}{2}$ inch on shorter lines and ± 1 inch on longer lines, depending upon whether the line has been stretched or compressed in handling.

**HIGH EFFICIENCY DECATHLON SERIES GAS FRYERS
CHAPTER 2: PARTS LIST**

Appendix: Pre-Common Cabinet HD65 Parts List

ITEM	PART #	COMPONENT
*	823-5243	Frypot - S/S
*	810-2072	Gas Manifold (weld assembly)
*	810-2032	Pilot Burner, Natural/G20/25 Gas (primary and trailing)
*	810-2155	Pilot Burner, LP/G31 Gas (primary and trailing)
*	812-1674	Pilot Burner, Mod. Natural Gas (electronic ignition)
*	812-1677	Pilot Burner, Mod. LP Gas, Electronic Ignition
*	810-0705	Tube, Pilot Gas Supply, 1/4" x 23" (one-piece gasline)
*	810-0703	Tube, Pilot Gas Supply, 1/4" x 17 1/2" (one-piece gasline)
*	220-1231	Bracket, Manifold Support (right or left)
*	230-1431	Diffuser Assembly
*	810-2785	Burner, High Efficiency
*	200-8748	Heat Shield, Lower
*	200-8053	Heat Shield, Vessel
*	230-2057	Support, Burner
*	807-3552	Gas Valve, Natural Gas, Electronic Ignition, 24 VAC
*	807-3628	Gas Valve, LP Gas, Electronic Ignition, 24 VAC
*	807-3294	Gas Valve, Natural Gas, Standing Pilot, 24 VAC
*	807-3295	Gas Valve, LP Gas, Standing Pilot, 24 VAC
*	810-2156	Gas Valve, Natural Gas, 120 VAC
*	810-2323	Gas Valve, LP Gas, 120 VAC
*	807-2091	Gas Valve, G20/G25 Gas, 24 VAC (CE only)
*	807-2127	Gas Valve, G31 Gas, 24 VAC (CE only)
*	810-0691	Vent Tube
*	823-3347	Frame, Slide Base
*		Channel, Base
	106-7441	265
	106-7357	465
	106-6851	565, 665
*	823-4894	Hinge, Lower Left
*	823-4895	Hinge, Lower Right
*	823-5136	Hinge, Upper Left
*	823-5137	Hinge, Upper Right
*	211-8078	Side Panel, Left Side (unit exterior)
*	212-8078	Side Panel, Right Side (unit exterior)
*	221-0012	Side Panel, Left Side with Hole (unit exterior)
*	222-0012	Side Panel, Right Side with Hole (unit exterior)
*	201-4237	Panel, Inner Left (divider located over filter unit)
*	202-4237	Panel, Inner Right (divider located over filter unit)
*		Cabinet Upper Back
	220-2474	x1 (Single)
	220-2353	x2 (2-, 4-, 5-, and 6-battery)
	220-0668	x3 (5-battery)
*		Cabinet Lower Back
	220-2483	x1 (Single)
	220-2354	x2 (2-, 4-, 5-, and 6-battery)
	220-0667	x3 (5-battery)
*	824-1195	Wireway, Control Panel

* Not illustrated.

**HIGH EFFICIENCY DECATHLON SERIES GAS FRYERS
CHAPTER 2: PARTS LIST**

Appendix: Pre-Common Cabinet HD65 Parts List (cont.)

ITEM	PART #	COMPONENT
19		Top Cap
*	824-1781	x1 (for single)
*	823-6010	x2 (for 2-battery)
*	823-6011	x4 (for 4-battery)
*	823-6090	x3 (for 5-battery)
*	823-5975	x2 (for 5- and 6-battery)
*	823-5976	x4 (for 6-battery)
*	824-1656	x3, with work shelf
*	230-2472	x1, HD Marine
*	106-4375	Flue Box Assembly
*	200-8220	Front, Flue Box
*	200-8221	Back, Flue Box
*	200-8219	Shield, Flue Box
*	200-3649	Deflector, Flue (Single, HD, non-S/S) <i>(use screws 809-0437)</i>
*	210-6525	Deflector, Flue (Single, Chili's, S/S) <i>(use screws 809-0437)</i>
*		Flue Cap
	230-2473	x1 (Single)
	230-2298	x2 (2-battery)
	230-2323	x3 (3- and 5-battery)
	230-2344	x4 (4- and 6-battery)
*	106-4309SP	Door Assembly, with Liner <i>(also used for HD63 fryers)</i>
*	200-8076	Panel, Door, Inner
*	210-8075	Panel, Door, Outer
*	210-8077	Handle, Door, Chrome
*	810-2346	Magnet, Door
*	803-0337	Fry Basket, 6 x 8 ³ / ₄ " x 16 ³ / ₄ "
*	803-0149	Grid Assembly, Mesh
*	810-2235	Grid Assembly, Rack
*	823-5859	Basket Hanger, Church's with Deflector
*	823-5801	Basket Hanger, Chili's Single System, 6" Splash Guard
*	823-5856	Splash Guard (2-, 4-, 5-, and 6-battery)
*	810-1494	Caster, Plate-mount 4" without Brake
*	810-2406	Caster, Plate-mount 5" without Brake
*	812-1226SP	Drain Nipple, Extended
*	807-0154	Cordset, 10' Power
*	210-9416	Cover, Outlet Duct
*	810-2411	Leg, Single Bolt Mount (black)
*	810-3169	Leg Package, 4 Bolt Mount (4 per set)
*	823-3248	Leg Support Assembly
*	200-8835	Burner Mounting Rail
*	200-8168	Post, Door
*	210-2804	Duct, Door Access

* Not illustrated.

THIS PAGE INTENTIONALLY LEFT BLANK



TM

DEAN®



Dean, 8700 Line Avenue, 8700 Line Avenue, Shreveport, Louisiana 71106

TEL 1-318-865-1711

FAX (Tech Support) 1-318-219-7135

PRINTED IN THE UNITED STATES

SERVICE HOTLINE
1-800-551-8633

819-6314
08/2016